

Networked Array Recorder (NeAR) Microphones for Field-Deployed Phased Arrays

William G. Culliton[§]
William M. Humphreys, Jr.*

NASA Langley Research Center, Hampton, Virginia

Abstract

An innovative edge-computing concept known as NeAR (Networked Array Recorder) has been developed to provide enhancements to existing field-deployable microphone phased arrays utilized for aeroacoustic flyover measurements of airframe and propulsive noise sources. The proposed system allows for the elimination of multiple miles of sensor wiring in an array installation, thereby improving the scalability of the overall system, increasing the fault-tolerance of the hardware, and reducing the effort needed to build-up and tear-down an array in the field. A demonstration of the NeAR concept was performed at Edwards Air Force Base in California in March – April, 2018, where twelve individual NeAR microphones were deployed as a piggyback on a conventional phased array system deployed for airframe noise flyover testing. The microphones operated successfully during the demonstration with good time history and spectral correlations shown between the NeAR units and conventional microphones located nearby in the array. The NeAR concept has spinoffs beyond its use for phased arrays, including applications in remote environmental sensing and noise monitoring.

I. Introduction

NASA has funded a number of projects over the past decade formulated to explore vehicle concepts and technologies that are designed to improve fuel efficiency, reduce noise levels, and decrease harmful emissions for both the current and future fleet of aircraft. These projects include the now completed Environmentally Responsible Aviation (ERA) Project [1] and its follow-on, the Flight Demonstrations and Capabilities (FDC) Project. In particular, the FDC Project promotes focused flight experiments to validate critical technologies, including noise reduction concepts [2]. These flight experiments require the use of measurement diagnostics, both aircraft- and ground-based, in order to quantitatively evaluate the benefit of specific concepts. In the realm of noise reduction characterization, one of the primary tools for such quantitative measurements is the microphone phased array.

The NASA Langley Research Center (LaRC) has a long history of successfully utilizing microphone phased arrays in both ground test facilities (i.e., wind tunnels) and for aircraft flyover testing [3-5]. In regards to the latter, the earliest use of these arrays for a large-scale Langley flight test campaign occurred in 2006 when a 167-microphone array was deployed over a 150-foot diameter area at the NASA Wallops

[§]Electronics Technician, Advanced Measurement and Data Systems Branch

*Aerospace Engineer, Advanced Measurement and Data Systems Branch, Associate Fellow AIAA

Flight Facility (WFF) [6]. Figure 1 shows an aerial view of the array deployed on the overrun area of Runway 4 at WFF. The microphones were low-cost, commodity electret units placed on the runway surface in a central mounting plate and on individual ground plates. A highly distributed signal conditioning and data acquisition system was deployed with most of the acquisition hardware housed in ventilated cabinets on the runway near the microphones. Although the data system was located in the vicinity of the microphones, a total of 11,690 feet of cabling was nevertheless required to connect the microphone outputs with the data system.



Figure 1. 167-microphone array at NASA WFF in 2006. Dots on overrun area are microphone ground plates. Data acquisition cabinets are visible around the array perimeter.

More recently, Langley conducted a series of three phased-array deployments at Edwards Air Force Base in California from 2016 – 2018 (referred to as ARM – Acoustic Research Measurements) where 185 hardened microphones (Figure 2) were deployed over a 250-foot diameter area, first on runway 18L (in 2016 and 2017) and then on the overrun area of then inactive runway 24 (in 2018) [7]. Figure 3 shows an aerial view of the array as deployed on runway 18L. For each of the Edwards deployments, the signal conditioning and data acquisition systems were housed in a command trailer located approximately 125 feet from the edge of the array. This necessitated the routing of 74,000 feet of cabling to the individual microphones, a process that consumed several days during the setup and tear down of the array hardware. It is noted that the logistical challenges in fielding these large arrays are not limited to Langley. The Boeing Corporation has reported in the literature the use of an 840-microphone, 288.5-ft diameter array system requiring the deployment of over 166,000 feet of cabling [8].

It is clear from the Edwards deployments that the scalability of the array in terms of adding more microphone channels to the system is reaching a practical limit, since the current LaRC architecture and array aperture configuration requires an additional 400-foot cable be added to the system for every new microphone that is deployed. (This requirement is needed to maintain signal level and phase uniformity where all of the cables in the legacy architecture have to be the same length regardless of the distance from a microphone to the data system.) The availability of

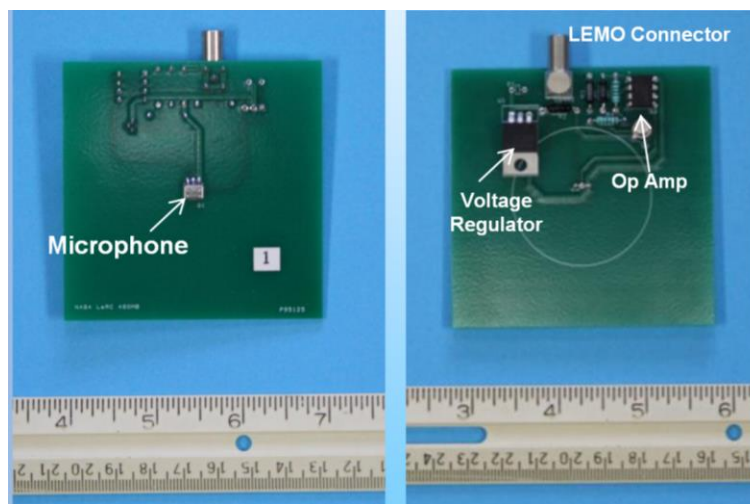

Figure 2. Hardened microphones utilized for ARM flight tests at Edwards AFB.

state-of-the-art microcontrollers and digitizers that can be positioned near each microphone to perform processing and storage of data at the sensor enables the overall array architecture to be redesigned. A more flexible system can eliminate the majority of the cabling, improve the scalability of the array as well as the fault-tolerance of the hardware, and simplify array deployment and tear-down during flight tests. The development of a suitable architecture satisfying these requirements was the motivation for the development of the NeAR



Figure 3. 2016 deployment of phased array at Edwards AFB.

(Networked Array Recorder) architecture described in this paper. It is noted that the NeAR concept is related to legacy microphone systems that LaRC has utilized for rotorcraft flight testing for a number of years, most notably the Wireless Acoustic Measurement System (WAMS) [9]. However, the WAMS system is designed for the deployment of a limited number of widely spaced microphones (over several miles in some cases) in order to measure vehicle noise footprints. In contrast, the NeAR system is designed to handle hundreds of microphones in close proximity for use in phased arrays.

II. NeAR Concept

The NeAR architecture places the signal conditioning and digitization hardware at each microphone, based on the concept of “edge computing” [10-11]. Edge computing (and the related field of “fog computing”) is receiving wide interest at present since it can be used as the front end for data fusion systems and is applicable to sensor monitoring networks [12-13]. For distributed sensor networks, edge computing refers to the capture and processing of sensor data at the edge of the network (in this case at the phased array sensors) versus transmission of raw data in real time to processing hardware at a central location. Edge computing is uniquely suited for collecting and processing data from phased arrays since it permits several key features: real-time analysis of data at the sensor level, reduction of the overall bandwidth requirements of the system, and improvement of the fault tolerance of the system by ensuring that the array will remain operational even if one or more sensors or edge computing nodes fails. This is in contrast to a central array acquisition and processing architecture where failure of the central system can cause the entire array to fail to operate.

The differences between a traditional phased array system architecture utilizing discrete cabling from each sensor back to a central data system versus the NeAR concept is depicted in Figure 4. In the traditional system shown in Fig. 4(a), all of the microphones must be connected directly to the central data acquisition system. Although only five representative microphones are shown in the figure, practical systems will have hundreds of microphones. There are many possible variations to an edge computing-based NeAR system, with one possible implementation shown in Fig. 4(b). Given the routine use of spiral arms in current phased arrays, the architecture shown in panel (b) represents the best trade-off between system complexity and minimization of hardware and cabling required to connect the microphones. The use of a separate NeAR interface with short cabling to the sensors allows a variety of different microphones to be employed depending on the application. Further, a single NeAR interface located at the end of a spiral arm in the array can handle the conditioning and digitization requirements for all of the microphones in that arm, using

wireless telemetry to relay the data from the arm to a host computer. Note that the incorporation of high-speed wireless telemetry in the NeAR hardware as shown in Fig. 4(b) is the key to reducing the overall cable requirements. For example, the architecture shown in Fig. 4(b) could reduce the cabling requirements for the array shown in Fig. 3 by 83 percent. Alternate architectures could reduce the cabling requirements to near zero.

III. NeAR Architecture

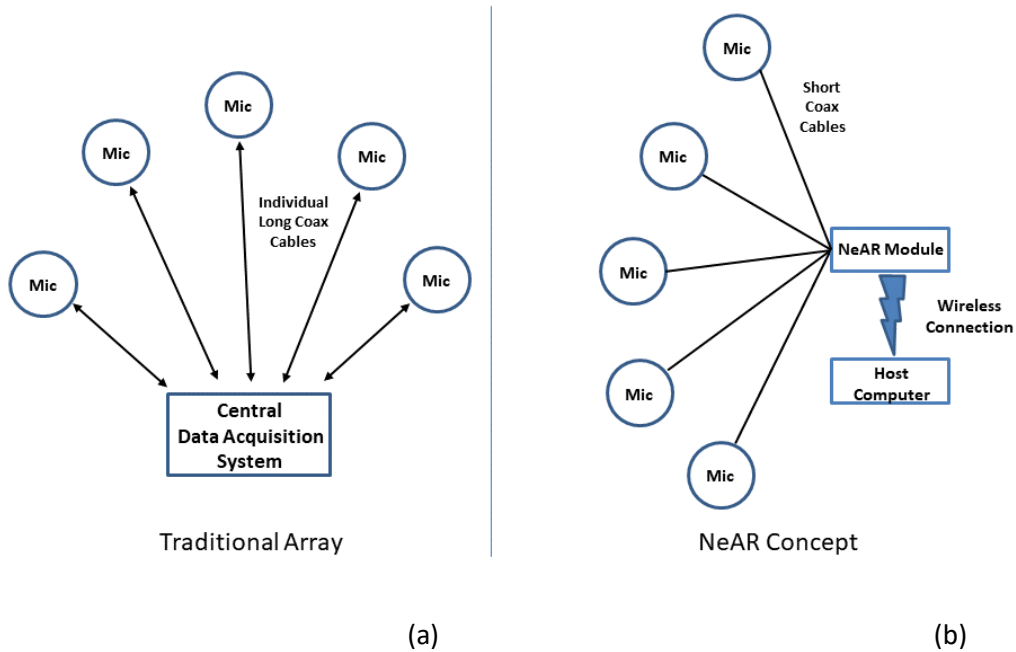

Figure 4. Comparison of (a) traditional architecture and (b) NeAR concept.

The NeAR hardware that was designed to implement the concept shown in Fig. 4 is modular and based on a series of discrete and repeatable subsystems that coordinate the functions of synchronization, signal conditioning, and capture of time history data from each of the microphones in the array. For the



Figure 5. NeAR module installation at Edwards. The microphone is on the round plate. The NeAR module is the square box.



Figure 6. Microphone mounted on top of NeAR module.

demonstration NeAR system described in this paper, the subsystems are housed in small individual modules (one for each microphone) that can be situated either next to each microphone (Figure 5) or with a microphone mounted directly on top of a module (Figure 6). This configuration was chosen for convenience given that only a small number of microphones are utilized in the demonstration system. A block diagram of the architecture within each enclosure is shown in Figure 7 with a photograph of the interior of a module shown in Figure 8. The various subsystems and components housed within a module are described below.*

Microphone Power: Each module implements a 4-mA current loop source for powering the microphones of the type shown in Fig. 2. This allows the existing ensemble of 250+ microphones developed for the ARM field-deployable array system to be utilized without modification. Alternate versions of the NeAR concept could include the option of switching to simple voltage excitation of the microphones to reduce electronic component counts both within the module and on the rear side of the microphone printed circuit board shown on the right side of Fig. 2.

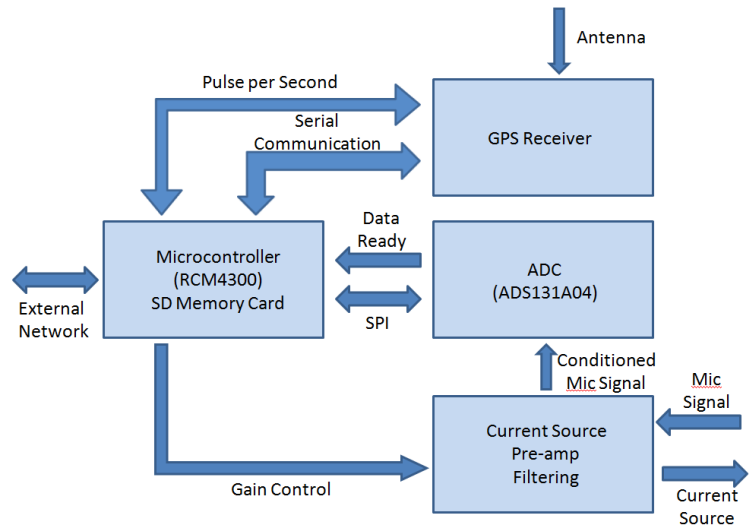

Figure 7. Block diagram of module subsystems.

Signal Conditioning: Each module implements a pre-amp / signal conditioning circuit that provides low-pass anti-alias filtering of the microphone signal along with a programmable gain control to increase the signal level prior to passing the signal to the digitizer. The current generation of the hardware incorporates a fixed cutoff frequency for the filter; however, this can easily be modified into a programmable filter in subsequent generations of the hardware.

Synchronization: One of the key features of the NeAR concept is the ability to synchronize the acquisition of time history data from all of the microphones in the array. Due to data processing requirements, it is critical that all data either be simultaneously sampled or that a mechanism be provided to “re-stack” all of the microphone time histories to a common time base. This is accomplished in the modules using a small Global Positioning System (GPS) receiver and



Figure 8. Photograph of module construction.

* Specific vendor and manufacturer names are explicitly mentioned only to accurately describe the test hardware. The use of vendor and manufacturer names does not imply an endorsement by the U.S. Government nor does it imply that the specified equipment is the best available.

timecode generator manufactured by Digilent (model PmodGPS). The GPS receiver is attached to a small form factor antenna (the black block shown on the top of the module in Fig. 5) to synchronize the receiver with multiple GPS satellite signals for precise timing. The ultimate purpose of the receiver is to generate an accurate pulse per second (PPS) signal that is then used to initiate acquisition of data. As will be seen, the ability to trigger independent modules synchronized to a GPS time base is an innovative aspect of the design and allows all acquisitions to be started at the same point in time even though the individual modules are clocked independently.

Digitization: Digitization of the microphone time history signal is accomplished using a Texas Instruments model ADS131A04 24-bit, delta-sigma analog-to-digital converter (ADC). For the demonstration system, the ADC is housed on an evaluation kit in the module to simplify assembly of the electronics. The ADC offers up to four simultaneous sampling differential inputs with data rates of up to 128,000 samples per second per channel. For the current generation of the NeAR system, the sampling rate of the ADC is fixed at 16,000 samples per second, although for future generations of the architecture the sampling rate can be made user-defined. Control of the ADC is accomplished using commands generated by the microcontroller in the module.

Command and Control / Storage: Command and control of a module is implemented using a Rabbitcore microcontroller manufactured by Digi International (model RCM4310). The microcontroller operates at 58.98 MHz and includes a 10/100Base-T Ethernet interface for external communication. The controller supports up to 36 individual parallel digital input/output lines for control of all of the other subsystems in the module. Local storage of data is enabled via a microSD memory card located on the microcontroller board. The main communications interface for a module is a 10/100 Base-T Ethernet port connecting directly with the microcontroller in the module. The use of an Ethernet port for communication allows each module to be assigned a unique IP address and be individually polled or controlled by a single host computer coordinating the entire NeAR-based array system. Note that this architecture allows for either wired or wireless LAN communication with a module. As will be seen in Section IV, there are instances where wireless communication is not permitted, requiring deployment of conventional Ethernet cabling.

Along with the development of the subsystems described above, custom software was developed for the NeAR architecture. The system embodies two distinct sets of software: (1) embedded firmware within an individual module, and (2) a separate host interface program running on a laptop that provides overall command and control to all of the modules and receives acquired data from them. A functional block diagram of the module firmware is shown in Figure 9. The firmware is written in Dynamic C (provided by the microcontroller manufacturer). The software includes drivers for network communication and SD memory card storage. One of the more challenging aspects of

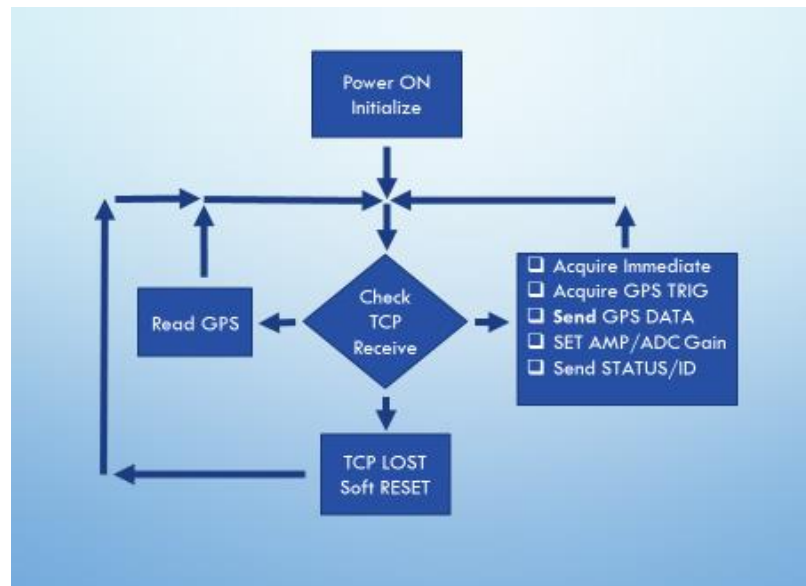

Figure 9. Firmware functional block diagram.

developing the software for the modules is programming the SD cards for storage. The SD card assembly code drivers that are provided with the microcontroller were modified specifically for the current architecture to allow the data from the ADC to be streamed to memory in real time. For the demonstration hardware the streaming rate was limited to 384 kilobits/sec per channel to ensure reliability, but this rate can ultimately be increased to over 3 megabits/sec per channel depending on the needed sampling rate for the microphones.

The host program is written in LabVIEW and provides for the viewing of near real-time microphone time histories as well as providing command and control of gain settings and data acquisition cycle times. Figure 10 depict a screenshot of the LabVIEW host program interface.

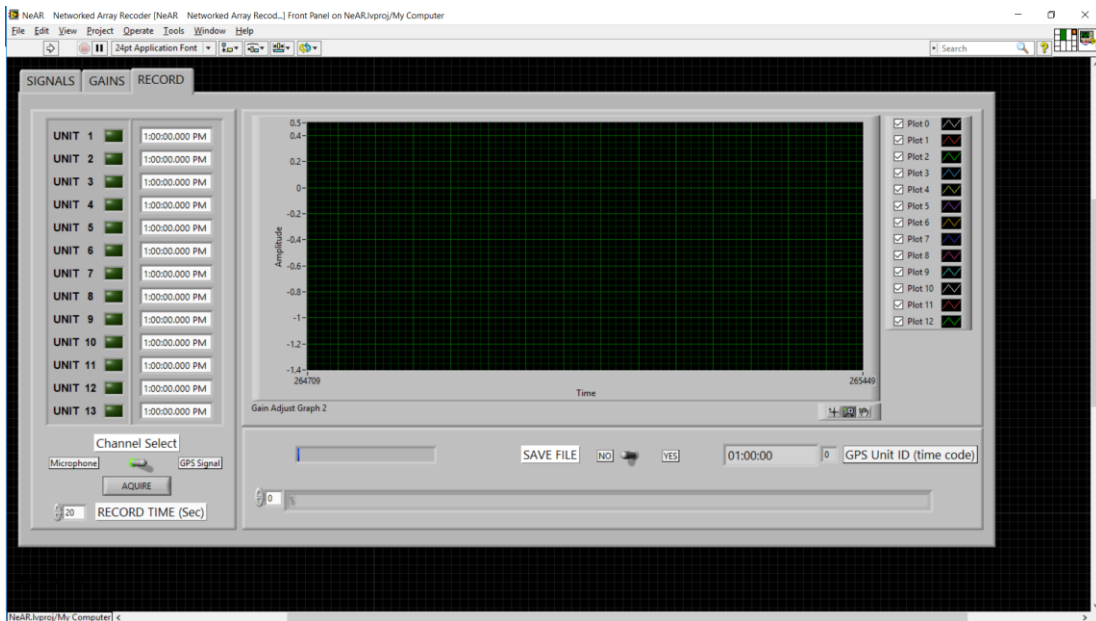

Figure 10. Host computer software – laptop screen shot.

IV. Demonstration of the NeAR Architecture

The first demonstration of the NeAR architecture was conducted at Edwards Air Force Base in California as a piggyback to the SCRAT (Subsonic Research Aircraft Testbed) ARM Phase III flight test conducted in March – April, 2018 [14]. Twelve individual NeAR modules were fabricated and included as part of the overall array pattern deployed during ARM III. Figure 11 shows the locations of the NeAR microphones and modules that were placed on the overrun area of runway 24 at Edwards in relation to the conventional microphones comprising the array. Due to radio frequency limitations at Edwards, for the demonstration the modules were connected to the host computer via Ethernet cabling versus using wireless connections. The modules and microphones were operated simultaneously with the conventional array microphones for a number of aircraft flyovers. One of the key goals of the demonstration was to assess the performance of the NeAR architecture in a relevant environment. The microphones and modules were deployed at the site for over 60 days and were subjected to a range of environmental conditions including desert sun, heat, cold, dust, rain and wind.

As described in Section III, the NeAR microphones were sampled at 16,000 samples per second to guarantee system reliability for this initial demonstration of the concept. This is in contrast to the 76,800 sample-per-second acquisition rate for the conventional microphones; therefore, resampling of the conventional microphone time histories was performed to provide a common time base for comparison. The conventional data acquisition system utilized for the array included a GPS-based timecode generator allowing both conventional microphones and NeAR microphones to be synchronized in time. Figure 12 shows some typical time histories collected with the NeAR microphones for an aircraft flyover pass.

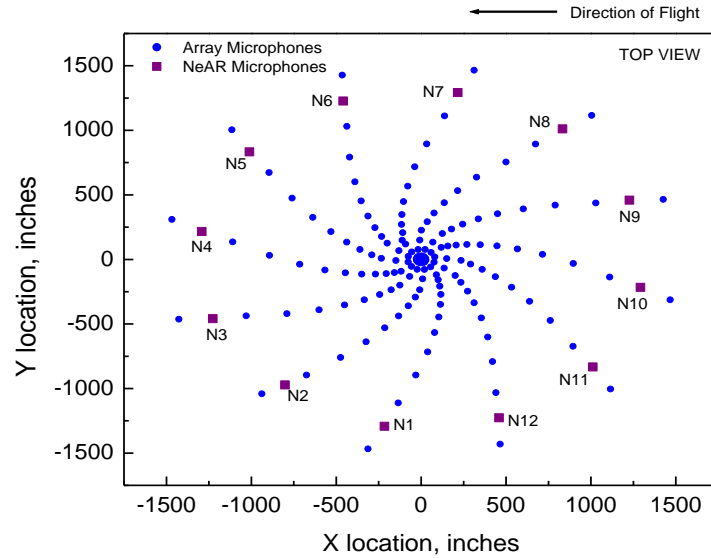

Figure 11. Locations of NeAR microphones during the 2018 ARM III flight test.

Note that during the ARM III piggyback test, glitches were observed in the synchronization of data at the start of data collection for some of the NeAR microphones (noted in Fig. 12), and one NeAR microphone (unit #1) failed during the deployment. The reasons for the loss of synchronization are not completely understood yet since the system worked flawlessly when tested in a laboratory setting. It is conceivable that environmental effects (large swings of temperature at the testing site or high moisture conditions for instance) could be a contributing factor.

Figure 13 depicts auto-spectra for the corresponding time histories in Fig. 12, computed over a 1-second interval centered at the location of the peak amplitude in the time histories (approximating the time for the

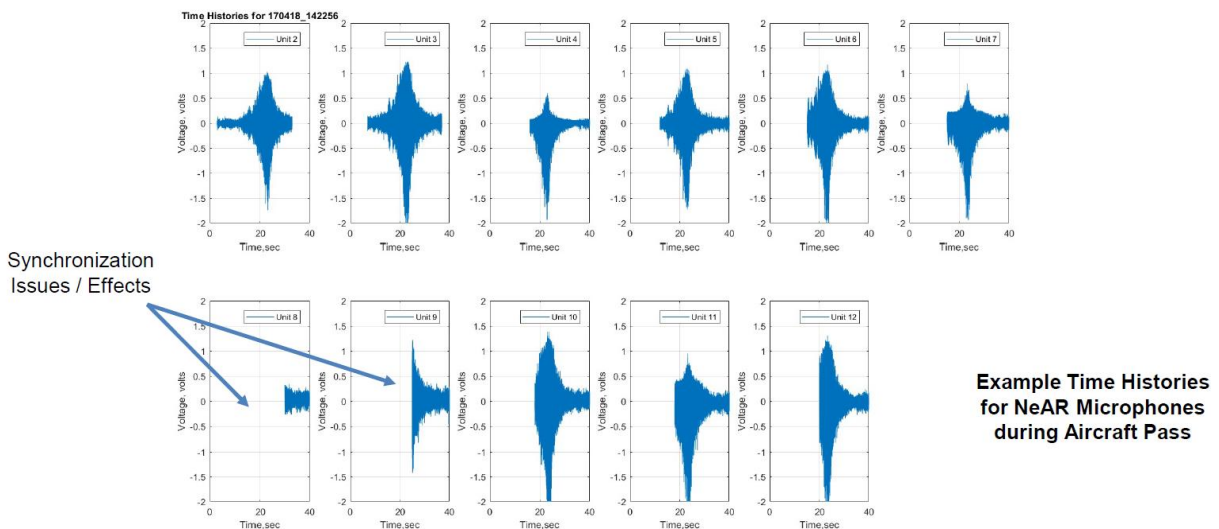

Figure 12. Example time histories from NeAR microphones for 2018 ARM III flyover. Note that some of the microphones exhibited synchronization issues during this pass.

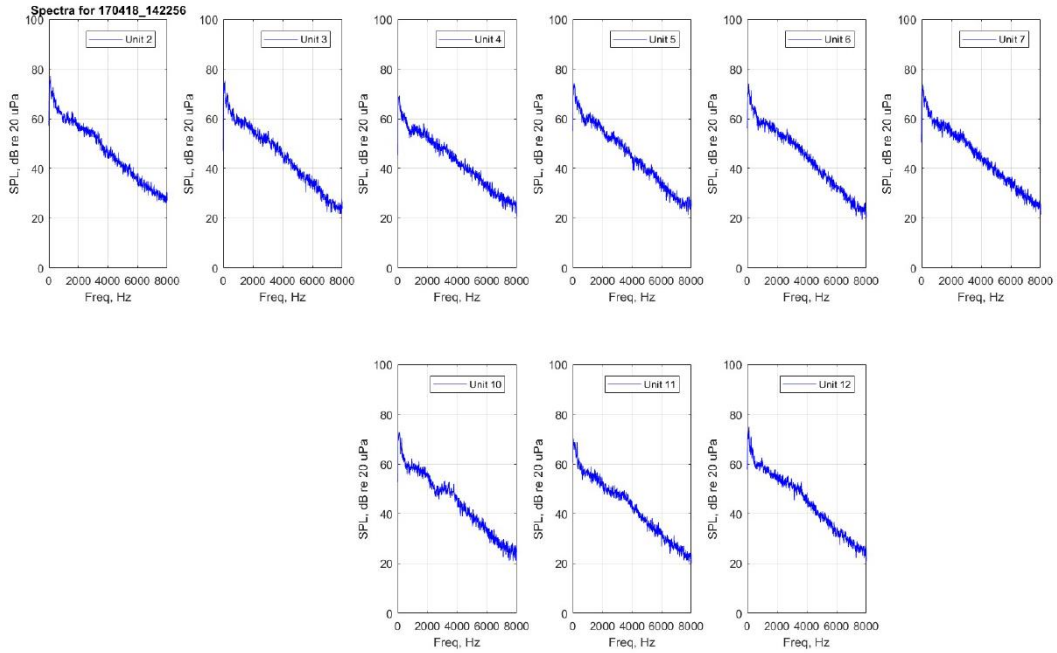

Figure 13. Auto-spectra for time histories shown in Fig. 12. Microphones with synchronization issues have been excluded.

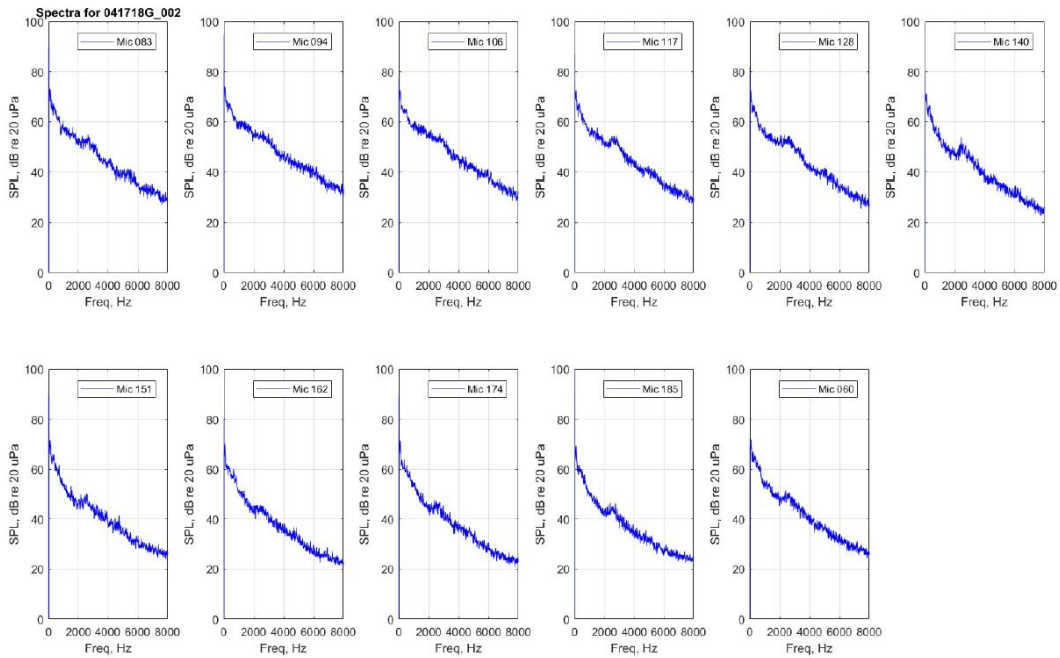

Figure 14. Auto-spectra for conventional array microphones located adjacent to NeAR microphones. Compare with auto-spectra shown in Fig. 13.

aircraft flyover of the array). The auto-spectra for those channels exhibiting synchronization issues have been deleted from the figure. Figure 14 shows corresponding auto-spectra for those conventional

microphones in the array closest to the NeAR microphones. Acceptable correlation is shown between the two sets of auto-spectra indicating that the NeAR architecture operated nominally during the demonstration. Visual discrepancies between the corresponding spectra shown in Figs. 13 and 14 can be attributed mainly to the fact that the microphones are not in the same location and are therefore subject to various external influences such as noise source directivity and wind.

V. Spin-off Applications

While the current NeAR concept has been tailored for use with microphone phased array systems, it is important to note that the types of sensors attached to the modules are not limited to microphones, and could include:

- Pressure sensors
- Temperature sensors
- Atmospheric sensors (wind, moisture, etc.)
- Any sensor providing a standard voltage or IEPE (constant current) output where edge computing of the sensory output is desired

This opens up the possibility of using the modules for a number of spin-off applications, including industrial noise monitoring where microphones need to be placed at a variety of locations around a plant. Other applications include remote environmental sensing using a collection of homogeneous or heterogeneous sensor arrays, and highway noise monitoring over a large area. The inclusion of a microcontroller in the individual modules allows for a number of processing operations to be performed on the acquired data before transmittal to the host, thereby increasing the possible applications for which this technology may be utilized.

VI. Summary

It is clear that new architectures are needed to allow better scalability of ever-larger microphone phased arrays utilized for flyover testing of aircraft. Thus, an edge-computing concept known as the Networked Array Recorder has been developed to provide the following enhancements to existing arrays: (1) the elimination of multiple miles of wiring of individual sensors in an array installation, (2) an improved scalability of the overall system by allowing for the straightforward addition of microphones to the array, (3) an improved fault-tolerance for the hardware where failure of one or more sensing elements or modules does not bring down the entire array, and (4) an improved efficiency in the build-up and tear-down procedures for the array. A demonstration of the concept was successfully performed at the Edwards Air Force Base in California in March – April, 2018, where twelve individual NeAR microphones were deployed as a piggyback on a phased array system deployed for airframe noise flyover testing. While there were some issues with data synchronization, in general the NeAR microphones operated nominally during the demonstration with good time history and spectral correlations shown between the piggyback microphones and conventional microphones located nearby in the array.

Looking forward, future planned work in the maturation of the NeAR concept will concentrate on the following:

1. Modifying the architecture to allow a single NeAR module to handle an entire arm of an array (up to 12 microphones per arm),
2. Improving the robustness of the modules to handle more extreme environmental conditions,
3. Increasing the sampling rate to allow acquisition bandwidths up to 20 kHz per channel, and
4. Improving the host software to allow for control of sampling rates, gains, and filtering.

Acknowledgments

The authors thank Dr. Mehdi Khorrami (NASA Langley Computational Aerosciences Branch) for allowing the piggyback of the NeAR microphones during the ARM III deployment. The authors also gratefully acknowledge the help of personnel at the NASA Armstrong Flight Research Center during the setup of the hardware at Edwards AFB. This work was funded by the NASA Flight Demonstrations and Capabilities (FDC) Project.

References

- [1] Collier, F. S., “Environmentally Responsible Aviation (ERA) Project”, *oral presentation*, NASA Fundamental Aeronautics Program, Third Annual Meeting, Atlanta, GA, 2009.
- [2] Baumann, E., and Waggoner, E. R., “Flight and Ground Operations in Support of Airframe Noise Reduction Tests”, AIAA Paper 2018-2970, 2018 AIAA/CEAS Aeroacoustics Conference, Atlanta, GA, 2018.
- [3] Humphreys, W. M., Jr., Brooks, T. F., Hunter, W. W., Jr., and Meadows, K. R., “Design and Use of Microphone Directional Arrays for Aeroacoustic Measurements,” AIAA Paper 1998-0471, 36th Aerospace Sciences Meeting and Exhibit, Reno, NV, 1998.
- [4] Humphreys, W. M., Jr., Brooks, T. F., Bahr, C. J., Spalt, T. B., Bartram, S. M., Culliton, W. G., and Becker, L. E., “Development of a Microphone Phased Array Capability for the Langley 14- by 22-foot Subsonic Tunnel,” AIAA Paper 2014-2343, 20th AIAA/CEAS Aeroacoustics Conference, Atlanta, GA, 2014.
- [5] Humphreys, W. M. Jr., Lockard, D. P., Khorrami, M. R., Culliton, W. G., McSwain, R. G., Ravetta, P. A., and Johns, Z., “Development and Calibration of a Field-Deployable Microphone Phased Array for Propulsion and Airframe Noise Flyover Measurements,” AIAA Paper 2016-2898, 22nd AIAA/CEAS Aeroacoustics Conference, Lyon, France, 2016.
- [6] Khorrami, M. R., Lockard, D. P., Humphreys, W. M., Jr., Choudhari, M. M., and Van de Ven, T., “Preliminary Analysis of Acoustic Measurements from the NASA-Gulfstream Airframe Noise Flight Test,” AIAA Paper 2008-2814, 14th AIAA/CEAS Aeroacoustics Conference, Vancouver, Canada, 2008.
- [7] Khorrami, M. R., Lockard, D. P., Humphreys, W. M., Jr., and Ravetta, P. A., “Flight-Test Evaluation of Airframe Noise Mitigation Technologies”, AIAA Paper 2018-2972, 2018 AIAA/CEAS Aeroacoustics Conference, Atlanta, GA, 2018.
- [8] Underbrink, J. R., “Pletharrays for Aeroacoustic Phased Array Applications”, *International Journal of Aeroacoustics*, Vol. 16, Nos. 4-5, pp. 202-229, 2017.
- [9] Anderson, P. D., and Dorland, W. D., “Wireless Acoustic Measurement System”, *NASA Tech Briefs*, pp. 5, February, 2007.
- [10] Lopez, P. G., Montresor, A., Epema, D., Datta, A., Higashino, T., Iamnitshi, A., Barcellos, M., Felber, P., and Riviere, E., “Edge-Centric Computing: Vision and Challenges”, *Computer Communications Review*, Vol. 45, No. 5, pp. 37-42, 2015.

- [11] Beckman, P., Sankaran, R., Catlett, C., Ferrier, N., Jacob, R., and Papka, M., “Waggle: An Open-Sensor Platform for Edge Computing”, IEEE Sensors Conference, Orlando, FL, 2016.
- [12] Mujica, G., Rodriguez-Zurrunero, R., Wilby, M. R., Protilla, J., Gonzalez, A. B., Araujo, A., Riesgo, T, and Diaz, J. J., “Edge and Fog Computing Platform for Data Fusion of Complex Heterogeneous Sensors”, *Sensors*, Vol. 18, pp. 3630-3656, 2018.
- [13] Sheng, Z., Pfersich, S., Eldridge, A., Zhou, J., Tian, D., and Leung, V., “Wireless Acoustic Sensor Networks and Edge Computing for Rapid Acoustic Monitoring”, *IEEE/CAA Journal of Automatica Sinica*, Vol. 6, No. 1, pp. 64-74, 2019.
- [14] Khorrami, M. R., Lockard, D. P., Humphreys, W. M., Jr., and Ravetta, P. A., “Flight-Test Evaluation of Landing Gear Noise Reduction Technologies”, 2019 AIAA/CEAS Aeroacoustics Conference, Delft, Netherlands, 2019.