

RELIABLE BONDING OF COMPOSITE LAMINATES USING REFLOWABLE EPOXY RESINS

Frank L. Palmieri^{1,*}, Tyler B. Hudson¹, Roberto J. Cano¹, Erik R. Tastepe², Dean S. Rufeisen², Luay U. Ahmed², Yi Lin³, Christopher J. Wohl¹, and John W. Connell¹

¹Advanced Materials and Processing Branch, NASA Langley Research Center,

²NASA Interns and Fellowships (NIFS), NASA Langley Research Center,
Hampton, VA 23681, USA

³National Institute of Aerospace, 100 Exploration Way, Hampton, VA 23666

*frank.l.palmieri@nasa.gov

ABSTRACT

Epoxy matrix composites assembled with adhesives maximize the performance of aerospace structures, but the possibility of forming weak bonds requires the installation of redundant fasteners, which add weight and manufacturing cost. Co-cured joints (e.g. unitized composite structures) are immune to weak bonds because the uncured resin undergoes diffusion and mixing through the joint. A means of co-curing complex structures may reduce the need for redundant fasteners in bondlines. To this end, NASA started the AERoBOND project to develop novel joining materials to enable a “secondary-co-cure” assembly process. Aerospace epoxy resin systems reformulated with offset stoichiometry prevented the resin from advancing beyond the gel point during a conventional autoclave cure cycle up to 180 °C. The offset resins were applied to the joining surfaces of laminate preforms as prepreg. Two surfaces with complimentary offset resins were joined using conventional secondary bonding techniques. Preliminary efforts have indicated that the resulting joint has no discernable interface and appears as a conventional co-cured laminate under optical magnification. This report will discuss the initial work performed regarding formulation of the epoxy resin system using calorimetry, rheology, and mechanical testing.

1. INTRODUCTION

Polymer matrix composites are common in high performance structures because of their excellent specific strength, toughness and stiffness in the fiber direction. To realize the full performance advantages of composites, complex, built-up structures must be assembled with adhesive bonds, but uncertainty in bond performance requires manufacturers to install bolts or other crack arrest features to ensure safety in critical applications [1]. The inherent uncertainty in adhesive bonds stems from the material discontinuity at composite-to-adhesive interfaces, which are susceptible to contamination and poor interfacial penetration or mixing [2]. In contrast, composites made by co-curing, although limited in size and complexity, result in predictable structures that may be certifiable for commercial aviation; potentially with reduced dependence on redundant load paths [1].

A technology, known as AdhESive fReE BONDing of complex composite structures (AERoBOND), is being investigated under NASA’s Convergent Aeronautic Systems (CAS) Project, which seeks to assess the feasibility of potentially transformative technologies. The AERoBOND concept uses a stoichiometric offset of the hardener-to-epoxy ratio on the faying surfaces of epoxy-based laminates. Assembly of the components in a subsequent “secondary-co-cure” process results in a joint with no material discontinuities (Figure 1).

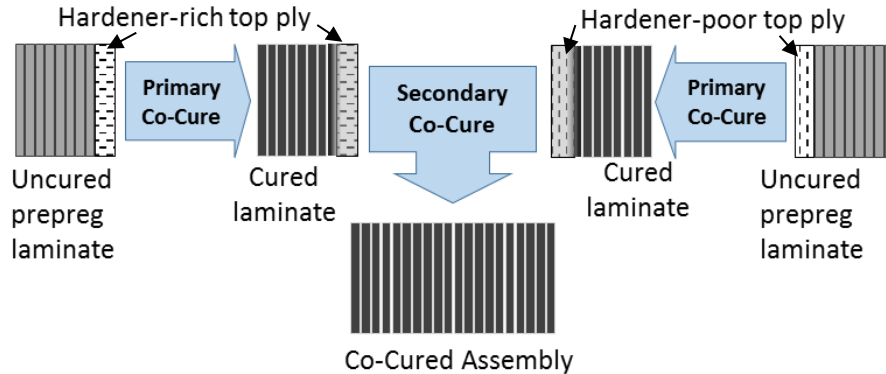

Figure 1: Schematic of assembly process using offset resin.

In one embodiment of this technique, composite components are prepared with a surface resin layer that is stoichiometrically rich in either hardener (Figure 1, left) or epoxy (Figure 1, right). As with all prepreg lamination and cure processes, the primary co-cure step uses heat to decrease the viscosity of the uncured resin allowing the resin to flow and the part to consolidate and cure. The resin reflow and consolidation steps are necessary to eliminate porosity and achieve full mechanical properties in the part. Because of the offset stoichiometry in the hardener-rich (HR) and hardener-poor (HP) surfaces, the reactive groups in excess remain intact and the resins on the faying surfaces remain flowable at elevated temperature after the primary cure. During the secondary co-cure step (Figure 1), the composite panels are joined and the surface plies intermix and cure to form a composite assembly with no discernable interface. Intermixing of the HR and HP resins occurs due to a concentration gradient, which drives diffusion and eliminates the material discontinuity in the joint. Intermixing of the HR and HP resins also reduces or eliminates the stoichiometric offset, and the molecular weight of the resin advances until vitrification occurs.

Other embodiments of this technique are also possible. For example, both components fabricated during the primary co-cure step could be HP, and a HR film could be applied between the components during the assembly analogous to adhesive bonding. The inverse is also possible if components with HR surfaces are joined using a HP film. Both of these variations allow for a greater variation in bondline thickness, and therefore, allow for larger tolerances for part fit-up.

1.1 Technical Challenges

To successfully assemble and co-cure a composite laminate structure using the AERoBOND technique, intermixing of resins across the interface must eliminate or greatly diminish the stoichiometric offset in the matrix resin. Incomplete mixing of the HR and HP layers will result in a stoichiometric offset in the matrix resin that may reduce mechanical properties near the interface. The degree of mass transfer across the joint depends on the resin viscosity, molecular weight, diffusion time, and degree of crosslinking. To control these characteristics, three parameters are

under investigation: 1) offset resin stoichiometry, 2) thickness of offset resin layers, and 3) cure cycle.

1.2 Gel Point of Crosslinking Resins

A tetrafunctional diamine was selected as the hardener for this work, and the epoxy is a mixture of 25 mol% trifunctional and 75 mol% tetrafunctional glycidal epoxy species. The stoichiometric ratio, r , is defined as the ratio (in moles) of hardener reactive groups to epoxy reactive groups. Using Equation 1, the ratios at gelation were calculated assuming full conversion of the limiting functional group [3].

$$\text{Equation 1} \quad r_{gel} P_{gel}^2 = \frac{1}{(f_e - 1)(g_e - 1)}$$

In Equation 1, P_{gel} is the conversion of the limiting monomer at gelation (assumed to be unity), r_{gel} is the ratio at the gel point, and f_e and g_e are the average functionality of the monomers, 4 and ~3.75, respectively. By this model, the resin is predicted to gel for $0.12 < r < 8.25$. Gelled polymers were expected to diffuse less readily than ungelled resin. Therefore, resins with r -values near the HR ($r = 8.25$) and HP ($r = 0.12$) gel points were investigated to determine their mass transfer across the interface during the secondary co-cure process.

This report describes the characterization work to select resin stoichiometries (r -values), which provide sufficient flow and reaction when cured to be appropriate for mechanical testing. Rheology and calorimetry were used to characterize the effect of stoichiometric offset on flow and cure properties. Resin formulations with acceptable flow and cure characteristics were identified, and the results of this preliminary study will be discussed.

2. EXPERIMENTATION

2.1 Materials

Epoxy resins were formulated from two components supplied by Applied Pleramic Inc. (now Kaneka North America): API-60[®] part A epoxy resin and 4,4'-diaminodiphenyl sulfone (DDS, m.p. 175-177 °C) part B hardener are shown in Figure 2.

Resins formulated from parts A and B were used for rheology and calorimetry testing. To measure baseline mechanical properties, prepreg was prepared from T700SC-12k carbon fiber from Toray[®] and premixed API-60 resin with an r -value of about 0.8 also obtained from Applied Pleramic Inc. Hexply[®] IM7/8552, 35%, 190 gsm tape was obtained from Hexcel Corporation[®] and used as backing for the mechanical test specimens. Methyl ethyl ketone (MEK), used to dilute the resin for prepreg preparation, was used as obtained from Sigma Aldrich[®].

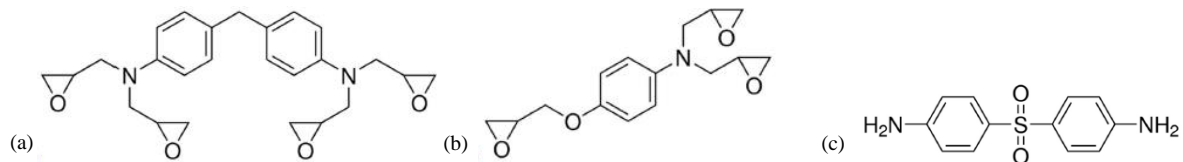

Figure 2: Structures of (a) the tetrafunctional epoxy, 4,4'-methylenebis(N,N-diglycidylaniline), (b) the trifunctional epoxy, N,N-diglycidyl-4-glycidyoxyaniline, and (c) the tetrafunctional hardener 4,4'-diaminodiphenyl sulfone (DDS).

A Thinky[®] planetary mixer was used to mix and degas all resin formulations at 100 °C by repeating a cycle with 4 min of mixing and 1 min of degassing 1-4 times. Due to the excess amount of DDS in HR formulations, some hand mixing and multiple cycles in the planetary mixer were required to achieve homogeneity based on visual assessment. Resins were cryogenically fractured at -79 °C to prepare powders for subsequent characterization tests.

2.2 Characterization

Rheology samples were prepared by pressing HR powder (~0.7 g) into disks while HP samples were heated to 90 °C and degassed under vacuum for 2 h. Parallel plate rheology was conducted on an Anton Paar[®] MCR 502 rheometer with aluminum, disposable, parallel plate fixtures with a gap of 1 mm and a 25 mm upper plate diameter. The temperature was ramped at 3 °C/min from 70 °C to 180 °C and held isothermally for 2 h before cooling to RT at 3 °C/min. An oscillatory test was used with a strain of 1% and a strain rate of 6.28 radians/s. A measurement was collected every 30 seconds.

Differential scanning calorimetry (DSC) was conducted on offset resins using a TA Instruments[®] Q20 modulated DSC with a heating rate of 3 °C/min, a modulation period of 60 s and amplitude of 0.96 °C. Samples of approximately 3 mg were hermetically sealed in aluminum pans and cured at 180 °C for 2 h before cooling to -40 °C and ramping to 280 °C to measure the glass transition temperature (T_g) of the cured resin and residual heat of reaction.

Unidirectional prepreg tape for fabricating mechanical test specimens was prepared using a custom prepregger from a resin solution of 70 wt% API-60 ($r = 0.8$) and 30 wt% MEK.[4] Twenty-ply, uni-directional laminates were prepared by laying up the Hexcel[®] prepreg and API-60[®] prepreg in a 30 cm by 30 cm format according to [Hexcel[®]/API-60₁]_s. Each panel was cured in an autoclave using the Hexcel[®] recommended cure cycle. Double cantilever beam (DCB) and single-lap shear (SLS) panels were machined using a water jet and curved beam (CB) panels were machined on a diamond wet saw to prepare six specimens for each sample. Testing and data reduction were conducted according to ASTM standards D5528-13 (DCB), D3165-07 (SLS), and D6415-06a (CB) [5-8]. Figure 3 shows the specimen configuration for each test.

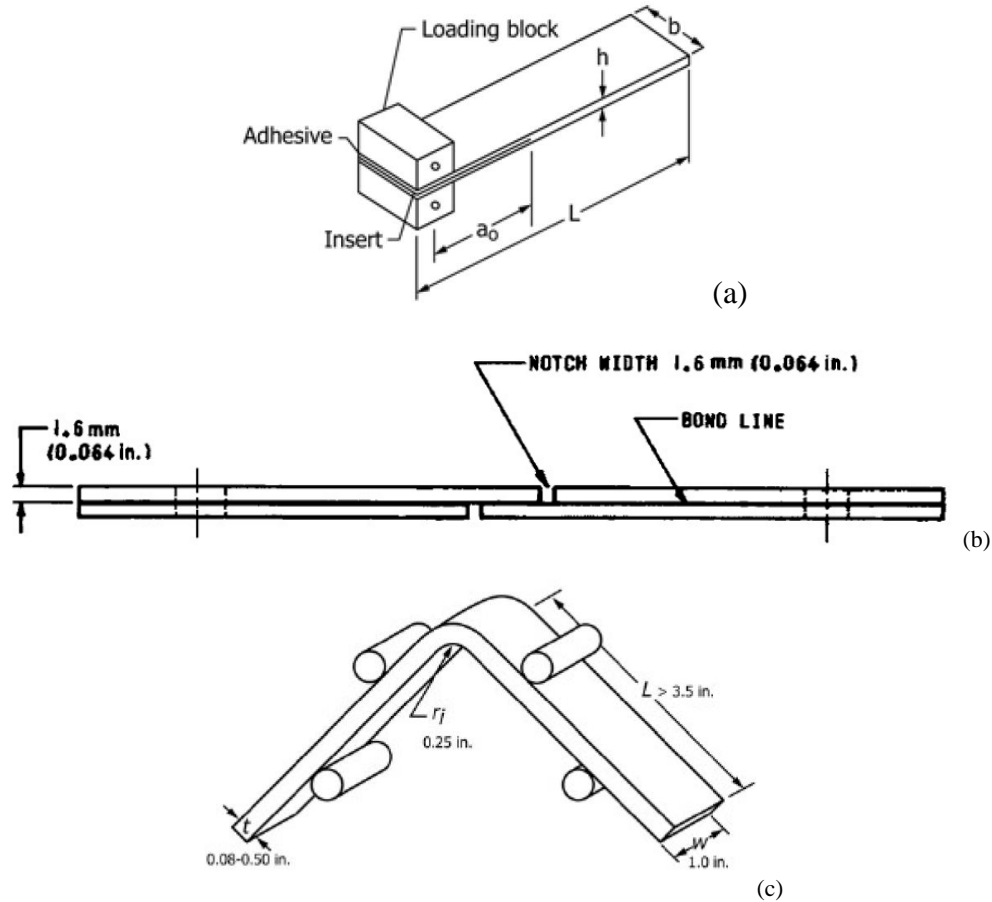

Figure 3. Specimen drawings for the three mechanical tests used to measure baseline properties: (a) DCB test, (b) SLS test, and (c) CB test.

3. RESULTS

3.1 Rheology

The rheological properties of HP and HR resin were measured for a range of offsets, and two cases are presented in Figure 4. The applied temperature (black curve) is the manufacturer recommended cure cycle (MRCC). The HR ($r = 5$) moduli (red curves) are generally higher than those of the HP ($r = 0.2$, blue curves) except for a sharp dip in the HR moduli likely due to the melting ($T_m = 172\text{ }^\circ\text{C}$) of the crystalline hardener powder. The viscosity of the HR curve then increases steeply and plateaus at the onset of the isothermal hold as the epoxy functional groups are exhausted and the polymerization stops. The gel point for the HR curves is observed near 3400 s where the storage modulus (G') exceeds the loss modulus (G''). The HR formulations tested with $r > 5$ did not indicate a gel point by this test. The HP curves gradually increased throughout the cure cycle. This may indicate that the epoxy continued to slowly homo-polymerize despite depletion of the hardener early in the reaction. Gelation of the HP resin appears to occur at the end of the isothermal hold, which did not occur in any of the formulations tested with $r < 0.2$. Lack of gelation above the theoretical gel point ($r = 0.12$) is likely due to incomplete conversion of the limiting monomer.

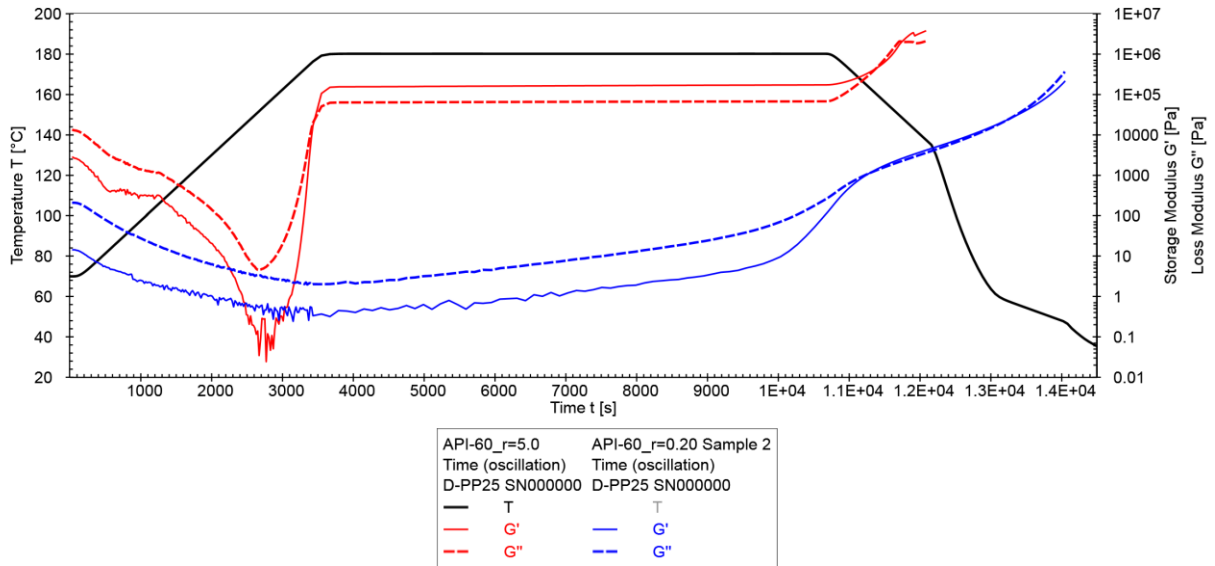

Figure 4. Storage modulus and loss modulus measured by parallel plate rheology of $r = 0.2$ and $r = 5$ resin systems. The applied cure cycle is indicated by the black curve.

The melt viscosities from rheology testing are presented in Figure 5 for the end of the isothermal hold at 180 °C and during the cooling ramp at 120 °C. The viscosity of the polymer melt increased smoothly for HP resin formulations as r increased towards one. For HR resin formulations the viscosity at 180 °C appears to go through a minimum between $r = 5$ and $r = 6.7$ due to gelation in the $r = 5$ formulation, which caused the viscosity to dramatically increase. The viscosity at 120 °C for the $r = 5$ formulation was above the measurement limits of the instrument under the test conditions used. The HR viscosity decreased for the range $6.7 < r < 10$ although the theoretical molecular weight increased as r approached one. Although it was not measured, the viscosity of molten 4,4'-diaminodiphenyl sulfone likely dominated the viscosity of the mixture for HR formulations due to its high stoichiometric excess.

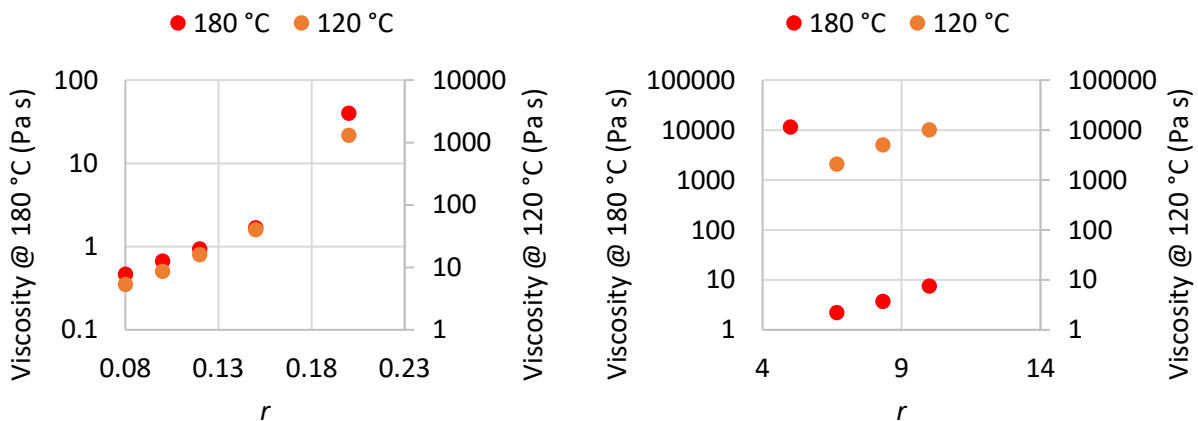

Figure 5. Dependence of melt viscosity on r for two temperatures, 180 °C and 120 °C. The left plot shows results for HP formulations, and the right plot shows results for HR formulations.

3.2 Molecular Weight Prediction

Using the model derived by Miller and Macosko, the molecular weight was predicted as a function of r assuming the polymerization consumed all of the limiting monomer (Figure 6) [3]. Asymptotes appear at r -values of approximately 0.12 and 8.26 in agreement with Equation 1. The form of the $r < 0.12$ function appears to match the rheology data in Figure 5 although it is shifted to lower r -values. Rheology data in Figure 5 does not correlate well with the $r > 8.26$ curve in Figure 6, which is probably due to the dominance of the hardener viscosity on the formulation.

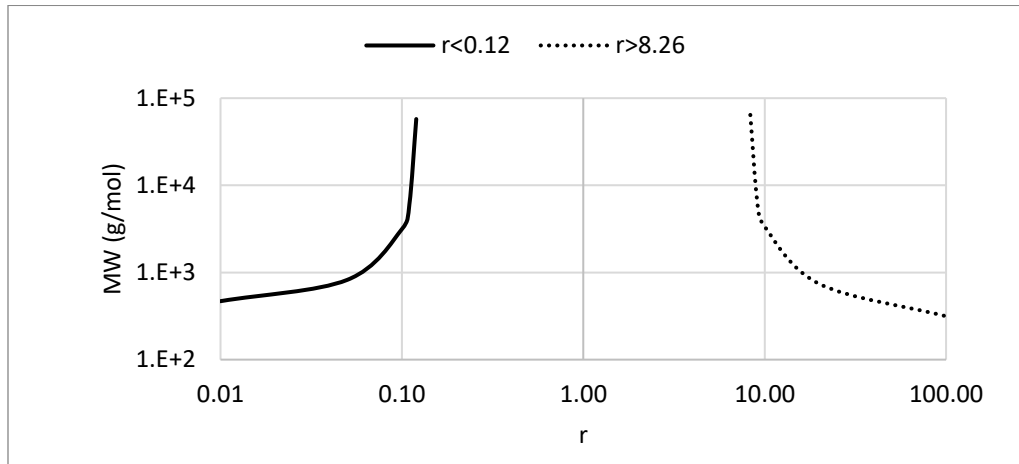

Figure 6. Predicted molecular weights for full conversion of the limiting functional group for various stoichiometric offsets.

3.3 Calorimetry

The calorimetry results in Figure 7 show the temperature measured at the peak of the exotherm that occurred during polymerization with respect to the r -value. The decrease in peak exotherm temperature with increasing r -value indicates that the amine-epoxy polymerization occurs at lower temperatures than the epoxy homo-polymerization. The calorimetry and rheology data indicate that homo-polymerization in HP resin formulations is slow at typical cure temperatures (~ 180 °C) and will not significantly advance the polymer.

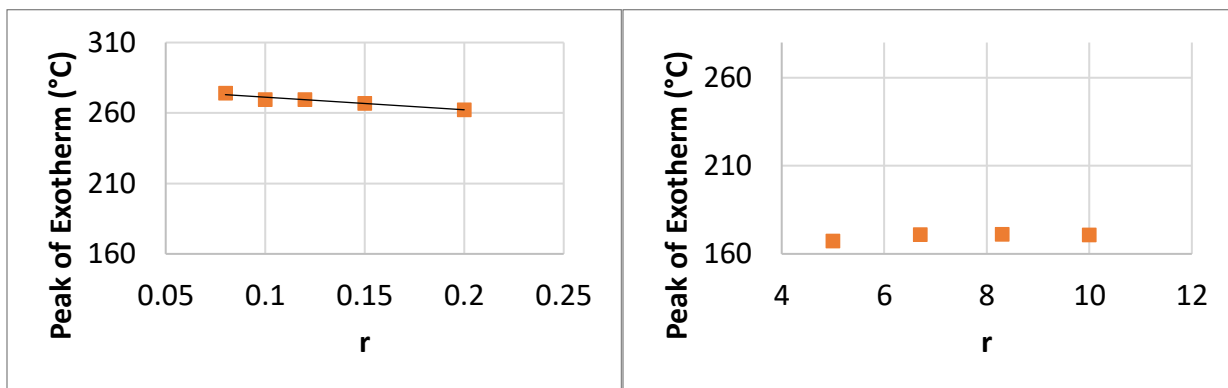

Figure 7. Peak temperature of the cure exotherm as a function of resin r -value measured by DSC. The left plot shows results for HP formulations, and the right plot shows values for HR formulations.

Based on calorimetry and rheology results, a small formulation window was selected for preparation of stoichiometric ally offset prepreg. The HR resin should be in the range of 5 to 6.7 near where the minimum viscosity was observed. The HP resin will be formulated with a complimentary r -value between 0.15 and 0.2. The down-selected formulations will be used to fabricate laminates and measure mechanical properties of AERoBOND joints as described in Section 3.4.

3.4 Mechanical Testing and Bondline Inspection

As described in Section 2.1, the custom prepreg used in this study was made from a solvent based process on a custom designed prepreg machine. In contrast, commercial prepreg is usually fabricated by hot melt processing. Due to the anticipated differences in prepreg quality, and possible effects of residual solvent present in the prepreg, baseline mechanical properties were measured from the custom prepreg rather than relying on literature data for comparison with AERoBOND joint properties to be measured in future experiments.

Preliminary mechanical test results are shown in Table 1 including the interlaminar fracture toughness (G_{IP}), the apparent shear stress (τ), and the interlaminar tensile strength (σ) measured using the DCB, SLS, and CB tests methods, respectively. The baseline properties measured here are representative of conventional materials made using the laboratory facilities available at NASA Langley Research Center to make the prepreg and laminates. These properties are for comparison with those measured from experimental joints, which remain to be fabricated and tested. The large error associated with σ was attributed to fiber waviness defects in the laminate that occurred during forming of prepreg on the curved beam tool.



Figure 8. Configuration of AERoBOND laminates for mechanical testing.

Table 1. Mechanical test results for baseline laminates.

Sample	G_{IP} (J/m ²)	τ (MPa)	σ (MPa)
Baseline	351±30	16.4±0.64	71.4±35.6

Figure 9 shows a cross-section image for the bondline of a co-cured interface (left) cut from a mechanical test specimen in comparison with a similar image of a co-bonded joint (right) with adhesive. In the co-cured joint, two plies, comprised of carbon fiber and conventional API-60 ($r = 0.8$) resin, from an interlaminar region with no visible polymer interface. In comparison, the co-bonded joint has an interface between the adhesive and substrate, which remains visible in the optical microscope. During the cure process, consolidation, which occurs due to resin flow and diffusion, eliminates the interfaces between prepreg plies. In the co-cured image, the matrix resin in the indicated area is a uniform color with no observable interface. Inhomogeneities seen in interlaminar regions away from the indicated region are toughener particles.

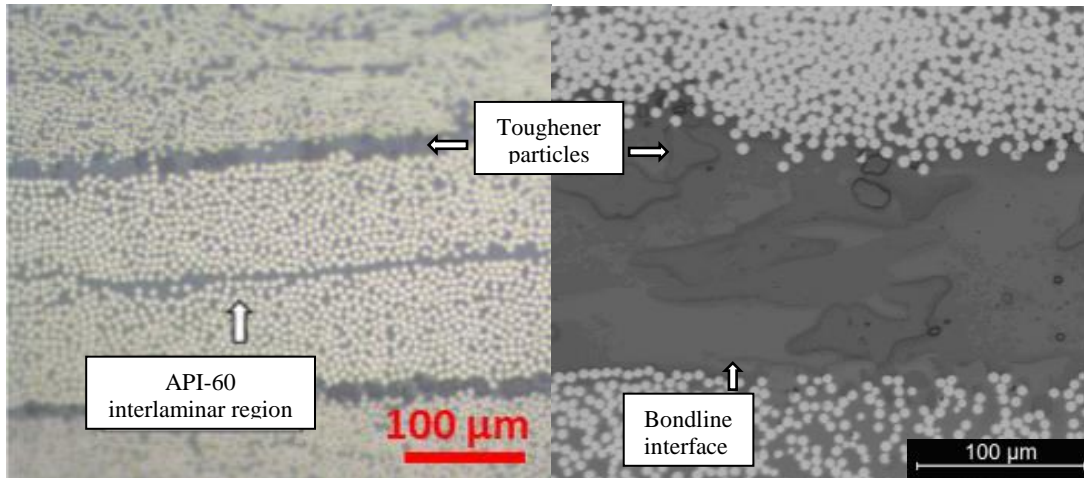

Figure 9. Cross-section micrographs of a baseline, co-cured laminate with API-60 plies at the center (left) and a secondary bonded interface (right).

Additional testing is planned to further characterize and determine the feasibility of an AERoBOND joint as shown in Figure 8. The tests primarily interrogate the interlaminar properties of the AERoBOND laminates in both tension and shear. The complete list of initiated and planned tests is shown in Table 2. Tests one through eight were selected to measure the material properties on the AERoBOND interface in both tension (mode I) and shear (mode II). Tests nine through eleven will be used to verify the material properties of the laminate and will only be conducted on a subset of samples.

Table 2: List of mechanical tests to measure material properties of AERoBOND joints.

Test Name	Test Standard
1. Single-Lap Shear	ASTM D3165
2. Curved Beam Test	ASTM D6415
3. Double Cantilever Beam Test	ASTM D5528
4. End Notch Flexure	ASTM D7905
5. Flatwise tension	ASTM D7291
6. Double-lap Shear	ASTM D3528
7. Barely visible impact damage	ASTM D7136
8. Compression after impact	ASTM D7137
9. Flexural Properties	ASTM D7264
10. Tension Test	ASTM D3039
11. Compression Test (CLC)	ASTM D6641

4. CONCLUSIONS

Epoxy resins with large stoichiometric offsets prevented advancement of the resin significantly past the gel point at full conversion of the limiting reactive groups. Calorimetry and rheology testing indicated that resins with r -values predicted to gel at full conversion appeared to remain ungelled throughout a typical cure process at 180 °C for 2 h. Based on these results, narrow ranges for r -values (HP: $0.15 < r < 0.2$ and HR: $5 < r < 6.7$) were selected for further mechanical testing. The mechanical properties measured for conventional formulations ($r = 0.8$) serve as the

benchmark for on-going mechanical testing on laminates prepared using the offset resin formulations identified in this study.

5. ACKNOWLEDGMENTS

The authors thank Bryan Hayes of Kaneka (formerly Applied Polyeramics) for donating the epoxy resins and hardeners for this research. We thank Wenping Zhao of United Technologies Corporation for the donation of carbon fiber. Thanks is also due to NASA engineers Austin Smith, Gretchen Murri, and James Ratcliffe for supporting mechanical testing. Sean Britton, Hoa Luong, Mike Oliver, and Tom Hall completed panel fabrication and specimen machining.

6. REFERENCES

1. Kruse, T., Fuertes, T. A. S., Koerwien, T. and Geistbeck, M. "Bonding of CFRP primary aerospace structures - boundary conditions for certification in relation with new design and technology developments," *Proceedings of the 2015 International SAMPE Tech. Conf.* Seattle, WA, 2014 Society for the Advancement of Materials and Process Engineering. CD-ROM. 15 pp.
2. Palmieri, F., Ledesma, R., Fulton, T., Arthur, A., Eldridge, K., Thibeault, S., Lin, Y., Wohl, C. J. and Connell, J. W. "Picosecond pulsed laser ablation for the surface preparation of epoxy composites," *Proceedings of the 2017 International SAMPE Tech. Conf.* Seattle, WA, 2017 Society for the Advancement of Materials and Process Engineering. CD-ROM. 14 pp.
3. Macosko, C. W. and Miller, D. R., "A New Derivation of Average Molecular Weights of Nonlinear Polymers." *Macromolecules* **1976**, 9 (2), 199-206.
4. Cano, R. J., Johnston, N. J. and Marchello, J. "Solution Prepregging Quality Control," Anaheim, CA, 1995 40th SAMPE Symposium and Exhibition. 583-595 pp.
5. Palmieri, F., Ledesma, R., Cataldo, D., Lin, Y., Wohl, C., Gupta, M. and Connell, J. "Controlled contmaination of epoxy composites with PDMS and removal by laser ablation," *Proceedings of the 2016 International SAMPE Tech. Conf.* Long Beach, CA, 2016 The Society for the Advancement of Materials and Process Engineering. CD-ROM. 14 pp.
6. Standard test method for mode I interlaminar fracture toughness of unidirectional fiber-reinforced matrix composites, 2013, "Standard test method for mode I interlaminar fracture toughness of unidirectional fiber-reinforced matrix composites" ASTM International, West Conshohocken, PA, 2013, www.astm.org.
7. Standard Test Method for Strength Properties of Adhesives in Shear by Tension Loading of Single-Lap-Joint Laminated Assemblies, 2007, ASTM International, West Conshohocken, PA, 2007.
8. Standard Test Method for Measuring the Curved Beam Strength of a Fiber-Reinforced Polymer-Matrix Composite1, 2013, ASTM International, West Conshohocken, PA, 2013.