



**Utilizing Advanced Modelling Approaches for Forecasting Air Travel Demand:
A Case Study of Australia's Domestic Low Cost Carriers**

A thesis submitted in fulfilment of the requirements for the degree of Doctor of Philosophy

Panarat Srisaeng

MEcon. (Kasetsart University, Thailand)

BEcon (Chulalongkorn University, Thailand)

School of Aerospace Mechanical and Manufacturing Engineering

College of Science Engineering and Health

RMIT University

March 2015

Declaration

I certify that except where due acknowledgement has been made, the work is that of the author alone; the work has not been submitted previously, in whole or in part, to qualify for any other academic award; the content of the thesis/project is the result of work which has been carried out since the official commencement date of the approved research program; any editorial work, paid or unpaid, carried out by a third party is acknowledged; and, ethics procedures and guidelines have been followed.

Panarat Srisaeng

September 2015

Acknowledgement

There are many people I wish to acknowledge for the support they have provided during my study at RMIT University.

First, I would like to thank my supervisors, including Associate Professor Cees Bil, for the help and support given during the time of my candidature. In particular, I give special thanks to my co-supervisors, Dr Glenn Baxter and Dr Graham Wild, for their great help, support, guidance, dedication and assistance which enabled me to work through the critical phases of my study.

Second, I would like to thank a number of individuals including: Dr Steve Richardson for his assistance and the valuable insights he gave me regarding the genetic algorithm modelling; Professor Heather Mitchell for her comments on Econometric modelling; Yousef Lutfi Abdel Latif Abu Nahleh and Subramanian Ramasamy who generously shared their knowledge and understandings with me about the ANFIS modelling.

Third, my deep gratitude goes to Margaret Tein and Graham Matthews, who played multiple roles in my PhD journey, as second supervisor, supporters, problem solvers, editors, family members and more. I sincerely appreciate their professional guidance, warm support, generosity, love and the fact that they have always been my side to support me in times of hardship.

Fourth, I would like to express my thanks to the Office of the Higher Education Commission (OHEC), Ministry of Education, Thailand and Suan Dusit University for providing the PhD scholarship. I also acknowledge Qantas Australia's support, specifically in the person of Gareth Evans (CEO International), who provided me with considerable support for my research.

As well, I want to say thank you: to my best friend in Thailand, who inspired me to start this PhD, for constant support, encouragement and companionship when I needed it the most; to Freda my best friend sister, for her great support and friendship; as well as Tingting my best buddy for her sincere help. As well I also wish to extend my special thanks to Caspar Cumming for his help and support during the journey. There were many other people and friends, who provided help and encouragement with my studies in RMIT, though your names may not be mentioned here, all of you will be always remembered in my heart.

Finally, and most importantly, I would like to acknowledge and thank my family, my father, my sisters, and my uncle who have always supported, encouraged and blessed me in my academic aspirations.

I dedicate this PhD thesis to my mother and my brother who are no longer with us, but are always in my thoughts, and I'm sure they are so proud of me.

ABSTRACT

One of the most pervasive trends in the global airline industry over the past few three decades has been the rapid development of low cost carriers. Australia has not been immune to this trend. Following deregulation of Australia's domestic air travel market in the 1990s, a number of low cost carriers have entered the market, and these carriers have now captured around 31 per cent of the market. Australia's low cost carriers require reliable and accurate passenger demand forecasts as part of their fleet, network, and commercial planning, product definition, and for scaling investments in fleet and their associated infrastructure.

Historically, the multiple linear regression-based modelling approach has been the most popular and recommended method for forecasting airline passenger demand. In more recent times, however, new advanced artificial intelligence-based forecasting approaches – artificial neural networks (ANNs), genetic algorithm (GA), and adaptive neuro-fuzzy inference system (ANFIS) - have been applied in a broad range of disciplines. In light of the critical importance of passenger demand forecasts for airline management, as well as the recent developments in artificial intelligence-based forecasting methods, the key aim of this thesis was to specify and empirically examine three artificial intelligence-based approaches (ANNs, GA and ANFIS) as well as the multiple linear regression approach, in order to identify the optimum model for forecasting Australia's domestic low cost carrier passenger demand. This is the first time that such models – enplaned passengers (PAX Model) and revenue passenger kilometres performed (RPKs Model) – have been proposed and tested for forecasting Australia's domestic low cost carrier passenger demand.

The results show that of the four modeling approaches used in this study that the new, and novel, adaptive neuro-fuzzy inference system (ANFIS) approach provides the most accurate, reliable, and highest predictive capability for forecasting Australia's domestic low cost carrier passenger demand. The accuracy of the forecasting models (PAX/RPKs) was measured by four goodness-of-fit measures: mean absolute error (MAE), mean absolute percentage error (MAPE), mean square error (MSE), and root mean square error (RMSE).

ANFIS PAX Model: MAE = 213.0, MAPE = 4.36 per cent, MSE = 7.1×10^4 ,
and RMSE = 267.52.

ANFIS RPKs Model: MAE = 218.97, MAPE = 5.55 per cent, MSE = 8.2×10^4 ,
and RMSE = 286.81.

A second aim of the thesis was to explore the principal determinants of Australia's domestic low cost carrier passenger demand in order to achieve a greater understanding of the factors which influence air travel demand. In light of the evolving low cost carrier business models around the world, and the trend towards a 'hybrid' business model, a further aim of this thesis was to explore whether this strategy has also been adopted by Australia's low cost carriers.

The results show that the primary determinants of Australia's domestic low cost carrier demand are Australia's real best discount airfare, Australia's population size, Australia's real GDP, Australia's real GDP per capita, Australia's unemployment size, world jet fuel prices, Australia's real interest rates, and tourism attractiveness. Interestingly three determinants, Australia's unemployment size, tourism attractiveness, and real interest rates, which have not been empirically examined in any previously reported study of Australia's domestic low cost carrier passenger demand, proved to be important predictor variables of Australia's domestic low cost carrier passenger demand.

The thesis also found that Australia's low cost carriers have increasingly embraced a hybrid business model over the past decade. This strategy is similar to low cost carriers based in other parts of the world.

The core outcome of this research, the fact that modelling based on artificial intelligence approaches is far more effective than the traditional linear models prescribed by the International Civil Aviation Organization (ICAO), means that future work is essential to validate this.

From an academic perspective, the modelling presented in this study offers considerable promise for future air travel demand forecasting. The results of this thesis provide new insights into low cost carrier passenger demand forecasting methods and can assist low cost carrier executives, airports, aviation consultants, and government agencies with a variety of future planning considerations.

TABLE OF CONTENTS

ABSTRACT.....	iii
TABLE OF CONTENTS.....	v
LIST OF PUBLICATIONS	xiv
CHAPTER ONE: INTRODUCTION	1
1.1 Background	1
1.2 The Research Gap	3
1.3 Research Aims and Research Questions	5
1.4 Significance and Impact of the Study.....	8
1.5 Outline of the Thesis.....	10
CHAPTER TWO: ESTABLISHING THE CONTEXT: AUSTRALIA'S EVOLVING LOW COST CARRIER MARKET	11
2.1 Introduction.....	11
2.2 Evolution of Australia's Domestic Airline Market Policy.....	11
2.3 Emergence of Low Cost Carriers in Australia's Domestic Airline Market.....	15
2.3.1 Initial wave of LCCs in Australia (1990-1993).....	15
2.3.2 Duopoly period in Australia's domestic air travel market (1994-1999)	16
2.3.3 Second wave of LCCs in Australia's domestic air travel market (2000-2006)	17
2.3.4 The 'third' wave of LCCs in Australia's domestic air travel market (post-2006)....	21
2.4 Summary.....	26
CHAPTER THREE: ANALYSING LOW COST CARRIERS IN AUSTRALIA'S DOMESTIC AIRLINE MARKET	27
3.1 Introduction.....	27
3.2 Low Cost Carriers: Key Definition	27
3.3 Low Cost Carrier Business Model and Key Characteristics	28
3.3.1 Provision of a 'no-frills' service	28
3.3.2 Point-to-point (P2P) airline route networks	29
3.3.3 Operating short-haul services and homogenous aircraft fleets	31
3.3.4 Use of secondary airports	32
3.3.5 Simplified pricing and low cost distribution optimization.....	34
3.3.6 Focus on ancillary revenues.....	34
3.4 The Hybridization of Australia's Domestic Low Cost Carriers Business Models	35
3.4.1 Australia's low cost carrier's service and product offerings.....	36

3.4.2 Australia's low cost carrier's route network structures	38
3.4.3 Australia's low cost carrier's aircraft fleet structure	39
3.4.4 Australia's low cost carrier's pricing and distribution strategies.....	40
3.4.5 Australia's low cost carrier's focus on ancillary revenues	42
3.4.6 The hybridization of Australia's domestic low cost carriers business models: a summary.....	43
3.5 Summary	46
CHAPTER FOUR: FORECASTING DEMAND FOR LOW COST CARRIERS IN AUSTRALIA USING A CLASSICAL LINEAR REGRESSION APPROACH.....	48
4.1 Introduction.....	48
4.2. Factors influencing Australia's Domestic Low Cost Carrier Passenger Demand	48
4.3 Data Sources.....	53
4.4 Model Specifications and Estimation Procedures	54
4.5 Classical Linear Regression Modelling Results	59
4.6 Summary	69
CHAPTER FIVE: FORECASTING DEMAND FOR AUSTRALIA'S LOW COST CARRIERS USING AN ARTIFICIAL NEURAL NETWORK APPROACH	71
5.1 Introduction.....	71
5.2 Artificial Neural Network Modelling: A Brief Overview	71
5.3 Artificial Neural Network Architecture.....	73
5.3.1 Artificial neural network Input variables and data sources	76
5.4 Artificial Neural Network Model Evaluation	76
5.5 Training and Testing of the Artificial Neural Networks.....	78
5.6 Artificial Neural Networks Transfer Function	81
5.7 Artificial Neural Networks Modelling Empirical Results	82
5.7.1 Structure of Final Models	82
5.7.2 Results of Final Models.....	86
5.7.3 Discussion of Contributing Factors that influence Australia's domestic LCC passenger demand	99
5.7.4 Comparison of results with previous ANN-based domestic air passenger demand forecasting studies	101
5.8 Summary	102
CHAPTER SIX: FORECASTING AUSTRALIA'S LOW COST CARRIER PASSENGER DEMAND USING A GENETIC ALGORITHM	104
6.1 Introduction.....	104
6.2 Genetic Algorithm: A Brief Overview.....	104

6.3 Genetic Algorithm Process	105
6.4 The Genetic Algorithm Models for Forecasting Australia's Domestic LCC Passenger Demand.....	108
6.4.1 The GAPAXDE and GARPXSDE data and variables selection	108
6.4.2 The GAPAXDE and GARPXSDE genetic algorithm process.....	109
6.4.3 Model Evaluation Goodness of Fit Measures	112
6.5 The GAPAXDE and GARPXSDE modelling results	113
6.6 Summary.....	119
CHAPTER SEVEN: AN ADAPTIVE NEURO-FUZZY INFERENCE SYSTEM FOR FORECASTING AUSTRALIA'S DOMESTIC LOW COST CARRIER PASSENGER DEMAND	121
7.1 Introduction.....	121
7.2 Adaptive Neuro-Fuzzy Inference System (ANFIS) Architecture.....	121
7.3. ANFIS Models for Forecasting Australia's Domestic LCC Passenger Demand	129
7.3.1. ANFIS process.....	129
7.3.2. Data normalization	131
7.4 ANFIS Models Setup	132
7.5 ANFIS Models Data Training	136
7.6. ANFIS Model Evaluation Goodness of Fit Measures	139
7.7 ANFIS Modelling Results.....	141
7.8 Summary.....	150
CHAPTER EIGHT: EMPIRICAL RESULTS OF THE STUDY	152
8.1 Introduction.....	152
8.2 Comparison of the Models and Selection of the Best Performance Model.....	152
8.3 The Primary predictors of Australia's Low Cost Carrier Domestic Air Travel Demand	168
8.3.1 Australia's real best discount air fares	169
8.3.2 Australia's population size.....	172
8.3.3 Australia's real GDP	173
8.3.4 Australia's real GDP per capita	174
8.3.5 Australia's unemployment size	175
8.3.6 World jet fuel prices.....	176
8.3.7 Australia's real interest rates	177
8.3.8 Recorded bed capacities at Australia's tourist accommodation	179
8.3.9 Summary of the principal predictors of Australia's domestic low cost carrier passenger demand	181

8.4 The Hybridization of Australia’s Low Cost Carriers Business Models.....	182
8.5 Summary.....	185
CHAPTER NINE: CONCLUDING COMMENTS	186
9.1 Overview	186
9.2 The Requirement for Basic Research.....	187
9.3 To whom is this Research Useful?.....	189
9.4 The Study Approach.....	189
9.5 A Comment on the Modelling Results.....	191
9.6 Research outcomes.....	192
9.7 Overall Contribution to Knowledge of the Study.....	194
9.7.1 Air travel demand forecasting methodological contribution.....	194
9.7.2 Theoretical contribution.....	195
9.8 Study Limitations and Suggestions for Further Research	196
9.8.1 Data limitations	196
9.8.2 Suggestions for future research	197
APPENDIX 1 EXAMINATION OF THE HYBRIDIZATION AUSTRALIA’S LCCs BUSINESS MODEL DOCUMENT SOURCES	226
APPENDIX 2 MATLAB CODE FOR THE GENETIC ALGORITHM	230
APPENDIX 2.1 Matlab Code for GAPAXDE and GARPkSDE (Linear Form).....	230
APPENDIX 2.2 Matlab Code for GAPAXDE and GARPkSDE (Quadratic form).....	235
APPENDIX 3 AUSTRALIA’S LCCs PAX AND RPKS ARTIFICIAL ADAPTIVE NEURO-FUZZY INFERENCE SYSTEM (ANFIS) SURFACE DRAWINGS.	241
APPENDIX 3.1 ANFIS Surface Drawings for Australia’s LCC enplaned passengers (PAX) Model	241
APPENDIX 3.2 ANFIS Surface Drawings for Australia’s LCC RPK Model.....	252
APPENDIX 4 The <i>HAC</i> (heteroscedasticity and autocorrelation consistent) method of correcting the OLS standard errors	263
APPENDIX 5 A REVIEW OF THE MODELLING APPROACHES	265
APPENDIX 6 DATA TRENDS OF ALL VARIABLES	277

LIST OF FIGURES

Figure1.1.Australian LCC domestic market share: 2001 – 2011.....	2
Figure2.1.Development of Australia’s annual enplaned domestic passengers and revenue passenger kilometres performed (RPKs): 1944-2013.....	14
Figure2.2.Trends in Australia’s domestic airline air fares: October 1992-November 2013... ..	16
Figure2.3.Development of Jetstar Australia annual enplaned domestic passengers and revenue passenger kilometres (RPKs): 2004/2005-2012/2013	21
Figure.2.4.Australia’s full service network and low cost carrier annual enplaned passengers: 2002-2012.....	23
Figure.2.5.Australia’s full service network and low cost carrier annual revenue passenger kilometres (RPKs): 2002-2012	24
Figure2.6.Development of Virgin Australia enplaned passengers.....	25
Figure3.1.Tigerair Australian domestic airline network	38
Figure3.2.Development of key attributes of Australia’s domestic LCCs’ business models ...	45
Figure4.1.The cyclical nature of world airline traffic growth: 1980-2012	50
Figure4.2.Schematic description of the steps taken in the econometric analysis of Australia’s domestic LCC passenger demand	57
Figure4.3.Durbin – Watson statistics.....	64
Figure4.4.Plots of the Australia’s domestic LCC PAX and RPKs multiple linear regression models residuals and fitted values.	65
Figure4.5.Distribution of the residuals for Australia’s domestic LCC PAX and RPKs models	66
Figure4.6.A comparison of Australia’s domestic LCC actual and forecast enplaned passengers (MLR Model).....	68
Figure4.7.A comparison of Australia’s domestic LCC actual and forecast RPKs (MLR Model)	69
Figure5.1.The artificial neural network (ANN) structure for forecasting Australia’s domestic LCC passenger demand	75
Figure5.2.The artificial neural network (ANN) modelling process	81
Figure5.3.The structure of the final Australia’s domestic LCC passenger demand multi-layer perceptron artificial neural network model.....	83
Figure5.4.Estimated weights of PAX model (Panel A to Panel D)	87
Figure5.5.Estimated weights of PAX model (Panel E to Panel H)	88
Figure5.6.Estimated weights of PAX model between the hidden units and the output unit ..	89
Figure5.7.Estimated weights of RPKs model (Panel A to Panel D)	90
Figure5.8.Estimated weights of RPKs model (Panel E to Panel H)	91

Figure5.9.Estimated weights of RPKs model between the hidden units and the output unit	92
Figure5.10.Regression plots for training, testing and validation phases and the total response in Australia’s domestic LCC passenger demand ANN PAX MLP model	94
Figure5.11.Regression plots for training, testing and validation phases and the.....	95
Figure5.12.The validation error in Australia’s domestic LCC passenger demand ANN PAX model.....	96
Figure5.13.The validation error in Australia’s domestic LCC passenger demand ANN RPKs model.....	97
Figure5.14.A comparison of Australia’s domestic LCC actual and forecast enplaned.....	98
Figure5.15.A comparison of Australia’s domestic LCC actual and forecast RPKs (ANN Model).....	99
Figure6.1.Genetic algorithm process.....	106
Figure6.2.A comparison of Australia’s domestic LCC actual and forecast enplaned	118
Figure6.3.A comparison of Australia’s domestic LCC actual and forecast RPKs	119
Figure7.1.Fuzzy reasoning mechanism.....	123
Figure7.2.Architecture of the ANFIS model with two inputs and two rules	124
Figure7.3.The ANFIS process for forecasting Australia’s	130
Figure7.4.The optimum ANFIS model architecture for forecasting	133
Figure7.5A.Initial and final Gaussian membership functions for the ANFIS PAX models...	134
Figure7.5B.Initial and final Gaussian membership functions for the ANFIS RPKs models.	135
Figure7.6.Error change during training of the ANFIS PAX model	138
Figure7.7.Error change during training of the ANFIS RPKs model	138
Figure7.8.Australia’s domestic LCC PAX actual and forecast values from	139
Figure7.9.Australia’s domestic LCC RPKs actual and forecast values from	140
Figure7.10.Australia’s domestic LCC enplaned passengers (PAX) or RPKs ANFIS forecasting system structure	142
Figure7.11.Australia’s domestic LCC PAX model actual and	143
Figure7.12.Australia’s domestic LCC RPKs model actual and	143
Figure7.13.An example of a rule set for forecasting Australia’s domestic LCC enplaned passengers (PAX Model)	144
Figure7.14.An example of a rule set for forecasting Australia’s domestic LCC RPKS (RPKS Model).....	145
Figure7.15.Obtained surfaces in ANFIS PAX model: PAX versus Australia’s population size and Australia’s GDP.....	146
Figure7.16.Obtained surfaces in ANFIS PAX model: PAX versus Australia’s population size and Australia’s tourist accommodation.....	146

Figure7.17.Obtained surfaces in ANFIS RPKs model: RPKs versus Australia’s population size and Australia’s GDP	147
Figure7.18.Obtained surfaces in ANFIS RPKs model: RPKs versus Australia’s population size and Australia’s tourist accommodation.....	147
Figure7.19A.Comparison of forecast and actual values of the ANFIS	149
models for forecasting Australia’s domestic LCC enplaned passengers (PAX)	149
Figure7.19B.Comparison of forecast and actual values of the ANFIS	149
models for forecasting Australia’s domestic LCC RPKs	149
Figure7.20.A comparison of Australia’s domestic LCC actual and forecast enplaned passengers (PAX) (ANFIS Model).....	150
Figure7.21.A comparison of Australia’s domestic LCC actual domestic and forecast RPKs (ANFIS Model)	150
Figure8.1.A comparison of Australia’s domestic LCC MLR, GA, ANN and ANFIS actual and forecast PAX models.....	162
Figure8.2.A comparison of Australia’s domestic LCC MLR GA, ANN and ANFIS actual and forecast RPKs models.....	163
Figure8.3.The relationship between Australia’s real best discount air fares and Australia’s domestic LCC passenger demand	172
Figure8.4.The relationship between Australia’s population size and Australia’s domestic LCC passenger demand	173
Figure8.5.The relationship between Australia’s real GDP and Australia’s domestic LCC passenger demand	174
Figure8.6.The relationship between Australia’s real GDP per capita and Australia’s domestic LCC passenger demand	175
Figure8.7.The relationship between Australia’s unemployment size and Australia’s domestic LCC passenger demand	176
Figure8.8.The relationship between Australia’s real interest rates and Australia’s domestic LCC passenger demand	179
Figure8.9.The relationship between Australia’s tourism attractiveness and Australia’s domestic LCC passenger demand	181

LIST OF TABLES

Table3.1.Comparison of low cost versus full service network carriers key attributes	27
Table3.2.Comparison of Jetstar and Tigerair Australia Airbus A320 key characteristics.....	40
Table4.1.Summary of the study dependent and independent variables, units of measurement, and data sources	54
Table4.2A.Correlation matrix for all independent variables	58
Table4.2.B. Correlation matrix of selected independent variables	58
Table4.3.The predictors of Australia’s domestic LCC passenger demand.....	60
Table4.4.Whites General Heteroscedasticity Test results for Australia’s domestic LCC PAX and RPKs passenger demand models	65
Table4.5.Classification for Mean Absolute Percentage Error (MAPE)	67
Table4.6.Performance index of MLR PAX and RPKs models for estimating, out of sample testing and overall data sets.....	68
Table5.1.Forecasting accuracy of Australia’s domestic LCC passenger demand artificial neural networks (ANN) MLP models	93
Table5.2.Performance index of ANN PAX and RPKs models for training, testing and overall data sets	98
Table5.3.The contributions of input variables	100
Table5.4.A comparison between the two previous studies and present study	102
Table6.1.A comparison of the results of the linear and quadratic forms of GAPAXDE model with observed data for the testing period.....	115
Table6.2.A comparison of the results of the linear and quadratic forms of GARPXSDE model with the observed data for the testing period.....	116
Table6.3.Performance index of GAPAXDE linear and quadratic models for training, testing (out of sample), and overall data set	117
Table6.4.Performance index of GARPXSDE linear and quadratic models for training, testing (out of sample), and overall data set	117
Table6.5.Results of paired t-test	118
Table7.1.Summary of the activities in forward and backward passes for ANFIS	137
Table7.2.Performance index of ANFIS PAX and RPKs models for training, out of sample testing and overall data sets.....	148
Table8.1.Classification for Mean Absolute Percentage Error (MAPE)	155
Table8.2A.A comparison of 4 models forecasting accuracy for Australia’s domestic LCC PAX	159
Table8.2B.Forecasting accuracy’s ranking of 4 Australia’s domestic LCC PAX modelling	159

Table8.3A.A comparison of 4 models forecasting accuracy for Australia’s domestic LCC RPKs	160
Table8.3B.Forecasting accuracy’s ranking of 4 Australia’s domestic LCC RPKs modelling	161
Table8.4.Results of paired t-tests.....	167
Table8.5.A summary of the independent variables included in the MLR, GA, ANN and ANFIS PAX and RPKs models	169

LIST OF PUBLICATIONS

Peer-reviewed journal

Srisaeng, P, Baxter, G, Wild, G 2014, 'The evolution of low cost carriers in Australia', *Aviation*, Vol. 18, No. 4, pp.203-216

Srisaeng, P, Baxter, G, Wild, G 2015, 'Forecasting demand for low cost carriers in Australia using an artificial neural network approach', *Aviation*, Vol. 19, No.2, pp.90-103.

Srisaeng, P, Baxter, G, Wild, G, 2015, 'Using an artificial neural network approach to forecast Australia's domestic passenger air travel demand', *World Review of Intermodal Transportation Research*, Vol.5, No.3, pp.281-313.

Srisaeng, P, Richardson, S, Baxter, G, Wild, G 2015, 'Forecasting Australia's domestic low cost carrier passenger demand using a genetic algorithm approach', *Aviation*, (Forthcoming Edition, Vol. 19, 2015).

Srisaeng, P, Richardson, S, Baxter, G, Wild, G 2015, 'Forecasting Australia's Domestic Airline Passenger Demand Using a Genetic Algorithm Approach"', *Journal of Aerospace Technology and Management*.

Srisaeng, P, Baxter, G, Wild, G 2015, 'An adaptive neuro-fuzzy inference system for forecasting Australia's domestic low cost carrier passenger demand', *Aviation*, (Forthcoming Edition, Vol. 19, 2015)

CHAPTER ONE: INTRODUCTION

1.1 Background

The vast size of the Australian continent, the country's varied and rugged topography, and scattered population present significant transport (and communication) challenges. Due to the vast distances across the country as well as between urban centres, Australia is heavily reliant upon its air transport industry (Nolan 1996). Australia's airline industry was founded on connecting regional communities to the country's major cities (Baker & Donnet 2012).

Australia's air transport industry has historically been tightly controlled by the government. In 1990 the Australian government commenced deregulation of the country's domestic airline market, permitting private competition, and privatising its interests in existing airlines (Nolan 1996). The government terminated the "Two Airline Policy", which had maintained a highly regulated domestic interstate air transport duopoly, and permitted other airlines to compete with established carriers in Australia's domestic market (Forsyth 2003; Nolan 1996). Since deregulation, a number of low cost carriers (hereafter LCCs) have entered the Australian domestic air travel market - Jetstar Airways, Tiger Airways and Virgin Australia, though since 2011 the latter has moved to a full service network carrier (FSNC) business model.

The emergence of low cost carriers (LCCs) has become a global phenomenon, with today virtually all travel markets containing at least some LCCs (Vasigh et al. 2008). The original LCCs business model was pioneered by US-based Southwest Airlines in 1971 (Daraban 2012; Doganis 2006) and it is still widely used around the world today (Alamdari & Fagan 2005; de Wit & Zuidberg 2012). LCCs are regarded as one of the most successful contemporary travel business concepts (Kua & Baum 2004).

In Australia, in the early 1990s, Compass introduced Australia's first LCC service. The airline was only in business for a short period, and was subsequently acquired by Qantas (Nyathi et al. 1993a). Virgin Blue commenced low cost operations in 2000. The airline began by firstly offering services on the trunk route Sydney-Melbourne. Virgin Blue offered very cheap fares, which were around fifty per cent lower than their competitors (Doganis 2006). Qantas established its low cost subsidiary - Jetstar Airways - in 2004. In 2007, Tiger Airways Australia was launched by its parent company, Singapore-based Tiger Airways (Thomas 2006a).

LCCs have played an important role in Australia's domestic air travel market. Since their inception of operations, Australia's LCCs' market share has grown significantly. This can be seen in Figure 1.1, in 2001, the LCC's market share accounted for 5.7 per cent of Australia's domestic airline market. The LCC's market share increased to 50 per cent by 2011 (Figure 1.1) (Centre for Aviation 2012). However, following the evolution of the Virgin Australia business model from an LCC to a full service network carrier since 2011, the LCCs market share has now declined to around 31 per cent. Australia's current major domestic incumbent LCCs are Jetstar Airways and Tiger Airways.

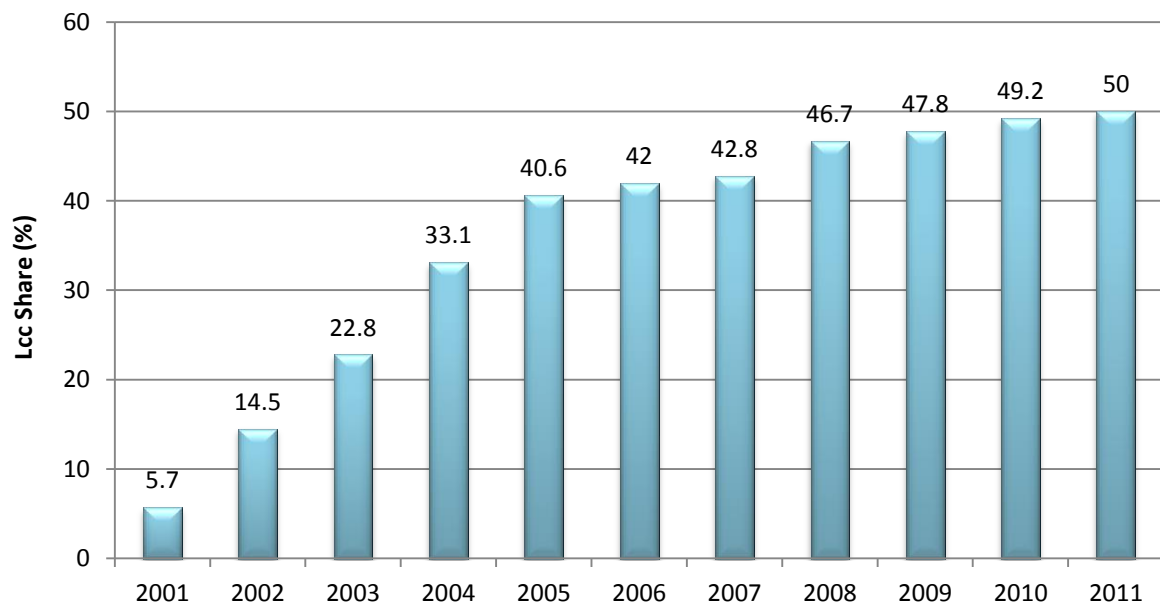


Figure 1.1. Australian LCC domestic market share: 2001 – 2011.
Source: Centre for Aviation (2012)

Forecasting future passenger travel demand is regarded as one of the most critical areas for airline management. Airlines forecast demand in order to plan the supply of services that are necessary to satisfy that demand (Doganis, 2009). Forecasting passenger transport demand is therefore of critical importance for airlines as well as for investors since investment efficiency is greatly influenced by the accuracy and adequacy of the estimation performed (Blinova, 2007). Air traffic forecasts are one of the key inputs into an airline's fleet planning, route network development, and are also used in the preparation of the airline's annual operating plan (Ba-Fail et al., 2000; Doganis, 2009). Furthermore, analysing and forecasting air travel demand may also assist an airline in reducing its risk through an objective

evaluation of the demand side of the airline business (Abed et al., 2001; Ba-Fail et al., 2000). Consequently, the forecasting of passenger demand plays an important role in decision making and planning for airlines.

1.2 The Research Gap

Forecasting future passenger travel demand is regarded as one of the most critical areas for airline management. In the air transport industry, many services providers and government regulatory agencies follow the International Civil Aviation Organization *Manual on Air Traffic Forecasting* (International Civil Aviation Organization 2006). This forecasting manual was originally developed in 1985 using traditional modelling techniques (Alekseev & Seixas 2009). This manual was updated in 2006 and recommends a number of quantitative passenger travel demand forecasting approaches: time series analysis (trend projection), and decomposition methods (exponential smoothing, Box-Jenkins, adaptive filtering, and spectral analysis). The ICAO notes that extensive use has been made of causal forecasting methods, which infer a cause-and-effect relationship. When utilized successfully, causal methods are able to predict the “ups and downs” in the air transport market. This mathematical process is, however, a testing procedure. The procedure is designed to evaluate whether the relationship of the dependent variable (as expressed in the causal model) to the explanatory (independent variables) is significantly related to these variables (International Civil Aviation Organization 2006).

Regression analysis is regarded by many as being by far the most important method for forecasting civil aviation passenger demand. In regression analysis, the forecast is based not only on the historical values of the item, for instance, enplaned passengers or revenue passenger kilometres performed (RPKs), being forecast but also other variables that are considered to have a causal relationship. Multiple regression analysis takes into consideration more than just a single independent variable, in contrast to the one variable used in simple regression analysis. The use of multiple regression analysis with a price-income structure is normally referred to as “econometric analysis” or “econometric modelling” (International Civil Aviation Organization 2006). A comprehensive survey¹ of the literature relating to previous air travel demand forecasting approaches used over the period 1950-2014 revealed that econometric modelling approaches, primarily using multiple linear regression, were used in eighty seven per cent of the reported studies.

¹ See Appendix 5.

In more recent times, however, a number of artificial intelligence-based forecasting methods have been proposed in the literature – artificial neural networks (ANNs), genetic algorithm (GA), and the adaptive neuro-fuzzy inference system (ANFIS). According to Yetilmezsoy et al. (2011, p.51), artificial intelligence-based modelling techniques “have become more popular because of their robustness, high predictive capabilities and flexible behaviours to handle the multi-objective criteria in a straightforward manner”. The use of new advanced artificial intelligence-based forecasting approaches have been applied for forecasting in a wide range of disciplines including, banking (Venkatesh et al., 2014), economics (Choudhary and Haider, 2012; Fang 2012; Giovanis 2012), energy demand prediction (An et al., 2014; Ghanbari et al. 2013; Jarimillo-Morán et al., 2013; Tamizharasi et al., 2014), electricity demand forecasting (Zahedi et al. 2013), tourism demand forecasting (Atsalakis et al. 2014; Claveria and Torra, 2014; Hadavandi et al. 2011; Hong et al. 2011), traffic accident prediction (Akgüngör and Doğan, 2009; Kunt et al., 2011), supply chain (Kochak and Sharma 2015; Latif et al. 2014), gold price forecasting (Makridou et al. 2013), oil consumption forecasting (Senvar et al. 2013), stock market forecasting (Chen et al. 2013; Cheng et al. 2013; Svalina et al. 2013; Wei 2013), transportation (Jiménez et al., 2014), and water demand prediction (Behboudian et al., 2014). However, there are only three previous studies that have proposed and tested artificial neural networks (ANNs) for forecasting a country’s domestic air travel demand (Alekseev & Seixas 2002, 2009) and (Blinova 2007). There are no published studies that have developed and empirically examined genetic algorithm and adaptive neuro-fuzzy inference system (ANFIS) approaches for forecasting airline passenger demand.

This study addressed this research gap by developing and testing three artificial intelligence-based models (ANNs, GA and ANFIS) for forecasting Australia’s domestic LCC passenger demand as well as a multiple linear regression model (MLR) – the first time that such a MLR model has been proposed and tested for forecasting Australia’s domestic LCC passenger demand. In order to identify the most accurate and reliable forecasting approach up to five goodness-of-fit statistics were used. The modelling results revealed that the adaptive neuro-fuzzy inference system (ANFIS) model provides the most accurate and reliable ability for forecasting Australia’s domestic LCC passenger demand. The models developed in the thesis can be used by LCCs, airports, aviation consultants, and government agencies in their forecasting and planning processes.

1.3 Research Aims and Research Questions

Multiple linear regression (MLR) analysis is regarded as being by far the most important and popular method for forecasting civil aviation passenger demand. In regression analysis, the forecast is based not only on the historical values of the item, for instance, enplaned passengers or revenue passenger kilometres performed (RPKs), being forecast but also other variables that are considered to have a causal relationship. This is the recommended passenger forecasting approach of the International Civil Aviation Organization (International Civil Aviation Organization 2006) and is therefore used extensively around the world.

As has been noted earlier, in more recent times, however, a number of artificial intelligence-based forecasting methods have been proposed in the literature – artificial neural networks (ANNs), genetic algorithm, and the adaptive neuro-fuzzy inference system (ANFIS). In light of the critical importance of forecasting passenger demand for airlines, and in the absence of any reported previous studies that have proposed and tested models for forecasting Australia's domestic LCC passenger demand, the first aim of the thesis was to empirically examine the recommended approach of the International Civil Aviation Organization (ICAO), that is, an econometric or linear regression model, with the artificial intelligence-based forecasting methods. The objective of this modelling was to identify the optimum model, in terms of accuracy, reliability and predictive capability, for forecasting Australia's domestic LCC passenger demand. In order to address this aim, the following research question was proposed:

What forecasting methods are available for estimating Australia's domestic low cost carrier passenger demand and how do they differ in applicability and capability?

This thesis also addresses a number of secondary aims. As previously noted, artificial intelligence-based modelling techniques have become more popular in diverse disciplines over the past decade (Kar et al. 2014). The popularity of this new approach is due to these model's robustness and high predictive capabilities. The flexible behaviour of these models is able to handle multi-objective criteria in a straightforward manner (Yetilmezsoy et al. 2011).

Artificial neural networks (ANNs) have been applied to a wide range of disciplines, including transportation (Jiménez et al. 2014); banking (Venkatesh et al. 2014); energy demand

prediction (An et al. 2013; Jarimillo-Morán et al. 2013); tourism demand forecasting (Claveria & Torra 2014; Palmer et al. 2006); traffic accident prediction (Akgüngör & Doğan 2009; Kunt et al. 2011); and economics (Choudhary & Haider 2012).

The genetic algorithm (GA) approach has been applied to a wide range of disciplines in recent times, including electric energy estimation (Ozturk et al. 2005); energy demand prediction (Ghanbari et al. 2013); housing price forecasting (Gu et al. 2011); tourism demand forecasting (Hernández-López & Cáceres-Hernández 2007; Hong et al. 2011); tourism marketing (Hurley et al. 1998); traffic accident severity prediction (Akgüngör & Doğan 2009; Kunt et al. 2011); and transport energy demand prediction (Haldenbilen & Ceylan 2005). In addition, Sineglazov et al. (2013) have proposed a genetic algorithm approach for predicting the short term demand for aircraft. The authors have also noted that their GA may be applicable to forecasting regional aviation facilities and could be used by other industrial sectors that have demand patterns similar to those experienced by airlines.

The adaptive neuro-fuzzy inference system (ANFIS) approach has been applied to a growing range of disciplines, including transport mode choice (Andrade et al. 2007); economics (Fang 2012; Giovanis 2012); electricity demand forecasting (Zahedi et al. 2013); financial markets forecasting (Bagheri et al. 2014; Kablan 2009); gold price forecasting (Makridou et al. 2013); oil consumption forecasting (Senvar et al. 2013); stock market forecasting (Atsalakis & Valavanis 2009; Chen et al. 2013; Cheng et al. 2013; Svalina et al. 2013; Wei 2013); tourism demand forecasting (Atsalakis et al. 2014; Chen et al. 2010; Hadavandi et al. 2011); and ordering policy in supply chains (Latif et al. 2014). There has only been one published study using an ANFIS-based approach to model air transport demand forecasting (Xiao et al. 2014). Xiao et al. (2014) proposed a time series data-based neuro-fuzzy combination model, which was based on singular spectrum analysis, for the short-term air traffic prediction at Hong Kong International Airport.

In the absence of any reported studies that have examined and empirically tested genetic algorithm or adaptive neuro-fuzzy inference system (ANFIS) models together with the very limited use of artificial neural networks (ANNs) for forecasting airline passenger demand, and, specifically Australia's domestic LCC passenger demand, the following research question was devised:

How do artificial intelligence-based forecasting models perform in terms of accuracy and reliability in low cost carrier passenger demand forecasting as compared to the traditional multiple linear regression approach?

The factors that influence air travel demand are complex (Doganis 2009; Vasigh et al. 2008). Each factor is composed of elements that can stimulate or reduce air travel demand. For airline passenger traffic demand forecasting purposes, these factors are more conveniently categorised into two broad groups. The first group comprises those factors that are external to the airline industry. The second group are those factors within the airline industry itself (Ba-Fail et al. 2000). The comprehensive search of the literature on previous air travel demand forecasting studies reported in the leading journals and literature, and presented in Chapter 2 showed that there are a range of socio-economic factors that influence air travel demand. Real GDP, real GDP per capita and air fares were the most common explanatory variables included in these studies (Ba Fail 2000; Sivrikaya & Tunç 2013). Other important factors that influence air travel demand reported in the literature include unemployment (McKnight 2010), tourism demand (Davidson & Ryley 2010; Graham 2006; Koo et al. 2013), world jet fuel prices (Gesell 1993, Li 2010), and real interest rates (Cook 2007; Wensveen 2011).

Despite the significance of Australia's domestic air transport industry, there have been only three previous studies that have attempted to forecast Australia's domestic air travel demand (Bureau of Transport Economics 1986, Hamal 2012; Saad 1983). Therefore, a second aim of the thesis was to explore the predictors of Australia's domestic LCC passenger demand so as to achieve a greater understanding of the factors which may influence the growth in their air travel demand. This investigation also sought to identify whether Australia's unemployment size, tourism attractiveness, and real interest rates are significant predictors of Australia's domestic LCC passenger demand. This was because there has been no previously reported study that has examined the influence of these factors on Australia's domestic LCC passenger demand. Thus, in order to obtain a greater understanding of the factors that may influence Australia's domestic LCC passenger demand, the following research question was asked:

What are the principal predictors of Australia's domestic LCC passenger demand?

Furthermore, Koo (2009) has noted that there are numerous variations to the LCCs business model. Indeed, it has been argued that the business models of many LCCs around the world have been evolving into what has been termed a 'hybrid' model (Tomová & Ramajová 2014; Vidović et al. 2013). Lawton (2002) states that research has shown that LCCs low-margin, high volumes and low-fare foci are distinguishing features of the LCCs as compared to the traditional full service network carriers² (FSNCs). In light of the evolving LCCs business models, and the trend towards a 'hybrid model', this thesis explored whether Australia's LCCs have moved towards a hybrid business model in recent years. Specifically, the following research question has been developed:

How have Australia's domestic low cost carriers business model followed that of other low cost carriers from around the world?

1.4 Significance and Impact of the Study

Forecasting is the process whereby projections, based on existing historical data, are made in regards to future performance. An accurate forecast assists airlines in their decision-making and planning for the future. Forecasts empower management to modify existing variables at the current time. Forecasts also assist a firm's management in predicting the future, so as to achieve a favourable viability scenario (Hadavandi et al. 2011).

Australia's domestic air travel market has experienced strong growth over the past forty years or so. The market has recorded strong growth particularly following the post-deregulation market period (post-1990). Due to the impact of air travel on transportation networks and the environment, forecasts of future demand for air travel, as well as the knowledge of the factors that positively or negatively influence air travel demand, are critical requirements in the formation of transportation policies (Darglay & Hanly 2001, cited in Wang & Song 2010). Reliable forecasts of air transport activity play a vital role in the planning processes of States, airports, airlines, aircraft maintenance organisations, engine and airframe manufacturers, suppliers, air navigation service providers and other relevant bodies. In addition these forecasts assist States, in facilitating the orderly development of civil aviation, and aiding all levels of government in the planning of air space and airport infrastructure. Examples are air traffic control (ATC) and airport airside and landside

² A "full service network carrier" is an airline that focuses on the provision of a wide range of pre-flight and on-board services, including different classes of service, and connecting flights (Ehmer et al. 2008).

facilities. Reliable forecasts also assist aircraft manufacturers in planning future aircraft types (in terms of size and range); and when to develop them (International Civil Aviation Organization 2006).

Demand forecasting is also essential for airlines when planning and scaling capital investment and infrastructure, and when scaling air transport related firms (Fernandes & Pacheco 2010). Forecasting is therefore considered the most important area of airline management. Airlines forecast demand, in order to plan the supply of services that are necessary to satisfy that demand (Doganis 2009). Forecasting passenger transport demand is, therefore, of critical importance for airlines as well as for investors since investment efficiency is substantially influenced by the accuracy and adequacy of the estimation performed (Blinova 2007). Air traffic forecasts are also one of the key inputs into airlines' fleet planning, route network development. They are also used in the preparation of the annual operating plans (Ba-Fail et al. 2000; Doganis 2009).

Furthermore, forecasting and analysing air travel demand may also assist airlines, in reducing their risks, through objective evaluations of the demand side of the airline business (Ba-Fail et al. 2000). Hence, the sustainable success of any firm is closely related to the ability of its management, and decision makers to foresee the future, and define and implement appropriate response strategies (Sivrikaya & Tunç 2013).

In light of the critical importance of forecasting passenger demand for airlines, and in the absence of any reported previous studies that have proposed and tested models for forecasting Australia's domestic LCC passenger demand, this thesis has empirically examined the recommended passenger forecasting approach of the International Civil Aviation Organization (ICAO), that is, an econometric or multiple linear regression model, with new and novel artificial intelligence-based forecasting methods. The major significance of this thesis is that it has found that the adaptive neuro-fuzzy inference system (ANFIS) approach provides the most accurate and reliable models for forecasting Australia's domestic LCC passenger demand and, is therefore, superior to the MLR forecasting approach that is currently extensively used in the global airline industry.

1.5 Outline of the Thesis

The thesis falls into nine chapters. The introductory chapter has laid the foundations for the study. It has discussed the research aims and questions and has presented a comprehensive literature review of the air travel demand forecasting and underlined the background to the research problem formulation. In Chapters 2 and 3 the contextual setting for the study are discussed, with the objective of highlighting their relevance as to what is the optimum modelling approach for forecasting Australia's domestic LCC passenger demand. Chapters 4 to chapter 7 presents the four modelling approaches for forecasting Australia's domestic LCC passenger demand. Chapter 8 builds on the empirical work presented in Chapters 4 to chapter 7. In this chapter the empirical findings from the study's modelling of Australia's domestic LCC passenger demand are discussed in detail. Chapter 8 also addresses the study's research questions. Chapter 9 summarizes the results of the study and assesses the implications of the study results and offers some suggestions for future research.

CHAPTER TWO: ESTABLISHING THE CONTEXT: AUSTRALIA'S EVOLVING LOW COST CARRIER MARKET

2.1 Introduction

An overview of the Australia's domestic airline market policy in the post-World War II period is discussed in section 2.2. It points out that Australia's domestic air travel market has evolved from being a tightly regulated market to a liberalised market following deregulation in 1990. Section 2.3 presents an overview of the evolution of Australia's low costs carriers highlighting the three discrete phases of LCCs entry that have occurred since deregulation of the market. The annual LCCs enplaned passengers, revenue passenger kilometre (RPKs) and market shares are also highlighted. This chapter provides the background for the more detailed modelling and analysis that follows in the subsequent chapters.

2.2 Evolution of Australia's Domestic Airline Market Policy

In 1949, the Australian federal government introduced a so-called "Two Airline Policy", initially by agreement but later legislated (Starkie 2008). Australia's "Two Airline Policy" became official in 1952 following the passage of the Civil Aviation Act (Mills 1989; Rhodes 2008, p. 96). Under this policy only two airlines were granted access to Australia's domestic trunk routes: Australian National Airways (later renamed Ansett Airlines) and the state-owned airline Trans Australia Airlines (TAA). In accordance with this policy the Australian government guaranteed the loans of Australian National Airways up to a set limit and later relaxed the requirement that all government employees should travel on Trans Australia Airlines (Rhodes 2008).

In 1957, the Australian government further declared that only two airlines would be authorized to operate on trunk routes and established a Rationalization Committee composed of a representative from each airline and a coordinator nominated by the Minister for Transport. The Airlines Equipment Act of 1958 also allowed the government to control the types of aircraft imported into the country, capacity and the entry of major operators to trunk routes (Grimm & Molloy 1993). Furthermore, during this time, competition, coordination of scheduling and domestic passenger fares was controlled by the government (Formby et al. 1990). The airlines were not permitted to withdraw from services unless a regional airline would take their place. Restrictions such as, level and structure of air fares, capacity and

regulatory barriers to entry were designed to support services by the two airlines across the national trunk route network (May et al. 1986). In 1961, two additional acts of Parliament authorized the Rationalization Committee to establish timetables, flight frequencies, aircraft types, available capacity, air fares, air cargo rates, and overall load factors on groups of routes (Rhodes 2008).

Despite the two major incumbent airlines (Ansett/Trans Australia Airlines) supposed competition with each other, in practice all areas where competition may have occurred were regulated, including air fares (Shaw 2011). In spite of some relaxation of the constraints within its policy, by the 1980s the policy was attracting criticism for stifling competition (Starkie 2008). Thus, in 1981, the government established the Holcroft Inquiry which recommended an air fare pricing policy based on cost to be nationally consistent and permit discounted air fares to be set by the airlines (Rhodes 2008). Also, in 1981, the government created an Independent Air Fares Committee to appraise air fares, approve discounts, and change fare formulas to take into account cost and efficiency. This enhanced the government's ability to control capacity of regional and cargo airlines through licensing of imported aircraft (Sinha 2001). The first sign of liberalization occurred in 1981 with an amendment to the *Airlines Agreement Act* which enabled regional airlines to operate jet aircraft (Collins et al. 2010).

Despite the adoption of an even tougher regulatory regime, disquiet increased about the Two-Airline policy. In 1985, the then Labor government appointed a committee to conduct an "Independent Review of Economic Regulation of Domestic Aviation". The committee's report was published at the end of 1986. Though the terms of reference enabled a wide-ranging review of the regulatory scheme to be conducted, the committee was not requested to recommend a new policy; instead it was to report on possible future policy options³ (Mills 1989).

In 1987 the Australian government announced its firm intention to remove any restrictions on entry to inter-state markets. In fact, it put the industry on three years notice. This change in policy was driven by several factors. Australia had an agenda of general deregulation during the 1980s. But, deregulation of the United States domestic air travel market in 1979 was a further potent factor and this was used as an example by those Commonwealth states pressing the federal government for a change to its domestic aviation policy (Starkie 2008).

³ See Mills (1989, pp. 210-211) for a summary of the committee's key findings and suggested policy options.

On the 7th October 1987, the Commonwealth Government provided Ansett and Trans Australia Airlines (TAA) with the required three years notice that the government would terminate the *Airlines Agreement Act* and deregulate the domestic airline industry. The removal of restrictions on domestic airlines other than Ansett and TAA operating commercial domestic charter flights with larger aircraft were also enacted at this time (Bureau of Transport and Communications Economics 1993). The principal features of the Australian government's new policy for interstate services were:

- Repeal of legislation: With effect in October 1990, the Australian Government will repeal the 1981 legislation regulating capacity, route entry, and air fares.
- Foreign ownership provisions: Any foreign international airline operating services to Australia will not be permitted to hold more than 15 per cent equity in any airline providing domestic services. Otherwise foreign firms may invest in Australian airline companies, subject to the normal guidelines of the Foreign Investment Review Board.
- Consumer protection: Airlines will become subject to all provisions of the Trade Practices Act; and air fares will be subject to scrutiny by the Prices Surveillance Authority (PSA), though the requirement for continued involvement of the PSA will be reviewed following an interim period of three years; and
- Domestic rights for Qantas: with effect from 1 July 1988, Qantas was granted the right to carry, on its domestic sectors, passengers of other international airlines (in addition to its right to carry its own international passengers) (Mills 1989).

On 1 November 1990, the entire industry was deregulated, ending the "Two Airline Policy" at the federal level (Forsyth 2003). The Airlines Agreement Act (1981) (Cth) s3, as well as the 1981 Airlines Agreement between the Commonwealth and the two major incumbent carriers was terminated. In 1990, the Commonwealth also withdrew from the application of passenger capacity provisions in the Airline Equipment Acts (1958-1981) (Cth). Also, in 1990, the Commonwealth announced its decision to privatise Australian Airlines (formerly TAA). The control of air fares through the Independent Air Fares Committee was also abolished with the disbandment of the commission (Moens & Gillies 2000). However, some state governments maintained economic regulation of intra-state routes, while at the national level, the Australian Competition and Consumer Commission (ACCC) monitored the state of competition in the industry in accordance with its generic competition responsibilities (Kain & Webb 2003). The regulation of competition, route entry and capacity were terminated. New domestic airlines were permitted on all domestic routes (Collins et al. 2010; Forsyth 2003).

Also constraints on domestic airlines were removed including: aircraft import control, capacity and supply control on trunk routes by each airline, entry and exit barriers to domestic trunk routes and abolition of the Independent Airfares Committee in setting fare levels (Bureau of Transport & Communication Economics 1991).

In September 1992 Qantas Airways acquired Australian Airlines (Moens & Gillies 2000; Quinlin 1998). The merged Qantas-Australian Airlines were partly privatised in 1993, a process completed in 1995 (Kong 1999). In 2001, the major event that occurred in Australia's domestic airline market was the collapse of Ansett Australia (Forsyth 2003; Prideaux 2003).

Figure 2.1 shows the annual growth in Australia's domestic enplaned passengers and revenue passenger kilometres performed (RPKs⁴) from 1944 to 2013.

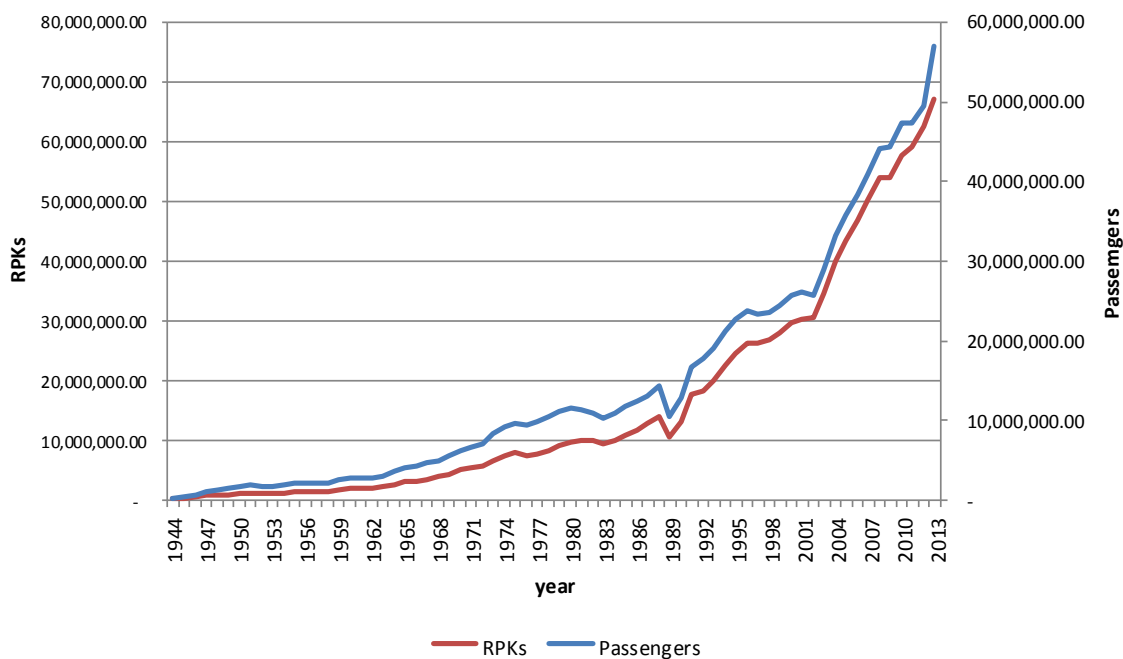


Figure 2.1. Development of Australia's annual enplaned domestic passengers and revenue passenger kilometres performed (RPKs): 1944-2013.

Source: Bureau of Infrastructure, Transport and Regional Economics (2014b).

⁴ Revenue passenger kilometres (RPKs) are obtained by multiplying the number of fare paying passengers on each flight stage by the flight stage distance (Doganis 2009, p. 327).

2.3 Emergence of Low Cost Carriers in Australia's Domestic Airline Market

Development of LCCs commenced in Australia in 1990 along with deregulation of Australia's domestic air travel market (Homsombat et al. 2014). As noted earlier, the market was dominated by two incumbent airlines: Qantas and Ansett Australia (Forsyth 2003). Deregulation opened the market and enabled new entrants to compete on all domestic routes (Forsyth 1998). Following deregulation of Australia's domestic air travel market on the 30th October 1990, LCCs have entered the market. Australia's LCCs market has had three discrete phases and these are presented in the following section.

2.3.1 Initial wave of LCCs in Australia (1990-1993)

In December 1990, soon after Australia's domestic market was deregulated, Compass Airlines was the first new entrant to the market (Quiggin 1997). Compass Airlines strategy was to compete as an LCC in Australia's domestic airline market. The airline operated a single aircraft type, the 266 seat Airbus A300-600 aircraft. The airline route network structure was quite simple, linking seven major airports (Collins et al. 2010). At one point in time, Compass had captured 10 per cent of the total domestic market and up to 21 per cent on routes that the airline served (Bureau of Transport and Communication Economics 1991). However, Compass experienced problems gaining access to airport slots and suffered from aircraft delivery delays (Grimm & Molloy 1993). Furthermore, Compass Airlines entry into the market was met with strong capacity increases by Ansett and Qantas, the two incumbent airlines, and this contributed to the airline's mounting debt (Koo 2009). Compass lasted for about a year, when its funds were exhausted following a strong price war with other incumbent airlines (Nyathi et al. 1993a, 1993b).

In 1992, shortly after Compass Airlines had collapsed, a second airline, which was called Compass Mark II, entered the Australian domestic market (Forsyth 2003). This airline operated for about six months until it too failed (Hooper 1998). Forsyth (2003) observed that although there were several favourable factors facilitating LCCs services, for instance, a number of dense routes and some leisure markets within Australia's domestic market, these were essentially offset by strong head-on competition with the incumbents, financial and marketing issues, and insufficient accessibility (Homsombat et al. 2014). In the event, no LCCs operated in Australia's domestic market for the remainder of the decade (Collins et al. 2010).

2.3.2 Duopoly period in Australia's domestic air travel market (1994-1999)

From 1994-1999 a duopoly comprising Ansett and Qantas emerged in Australia's domestic airline market (Koo 2009). Although no new LCC entered the market, two distinct post-deregulatory effects were observed during the period 1993 to 1996 in Australia. First, both enplaned passengers and revenue passenger kilometres performed (RPKs) continued to grow as illustrated in Figure 2.1 (above). The second effect related to air fares. As anticipated, average air fares declined following de-regulation of the market (Koo 2009). This trend was extensively documented in the air transport literature (for example, Doganis 2009; Holloway 2008). Figure 2.2 illustrates the significant increase in levels of air fare discounting in Australia that has occurred from October 1992 to November 2013. This figure also depicts the widening gap that has been occurring in Australia's domestic airline market between high and low fares (Koo & Lohmann 2013). These fluctuations in air fares are similar with those experienced in the post-deregulation effects observed in the United States (see for example, Borenstein & Rose 1994). Figure 2.2 shows that there has been a disparity in Australia's domestic air fares during the period 1992-2013. However, between 1996 and 1999, demand was flat, despite strong fluctuations in the levels of air fare discounting. This began to change from the late 1990s when two new LCCs entered the Australian domestic air travel market (Koo 2009).

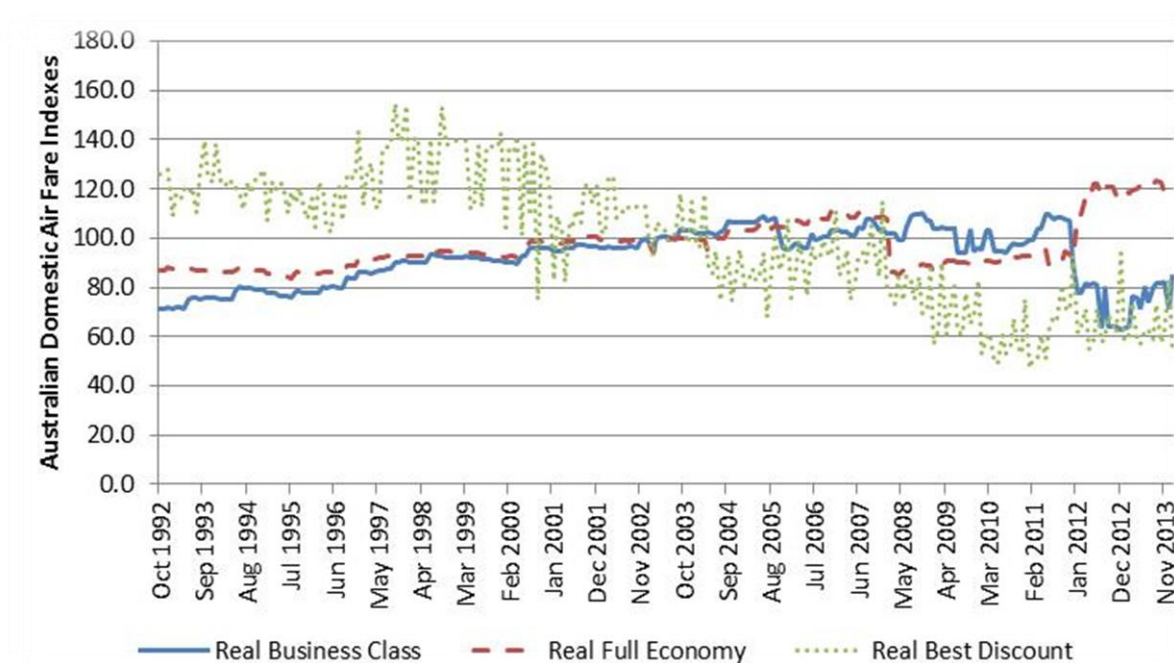


Figure 2.2. Trends in Australia's domestic airline air fares: October 1992-November 2013
Source: Bureau of Infrastructure, Transport and Regional Economics (2014a).

Note⁵: Real business class fares are based on Qantas (Business) and Virgin Australia (Business); real full economy (fully flexible, refundable) are based on Qantas (Fully Flexible), Skywest (SkyFlexi), and REX (Rex Flex) fares; and real best discount are Qantas (Red e-Deal or Super Saver), Virgin Australia (Saver), Jetstar (Starter), Tiger (Internet Discounted Fare), REX (Rex Saver or Rex Net) and Skywest (WEBBIT, SkyDeal).

2.3.3 Second wave of LCCs in Australia's domestic air travel market (2000-2006)

The second phase of LCC entry commenced in 2000 with the formation of Impulse Airlines and Virgin Blue (Homsombat et al. 2014; Koo 2009). Impulse was a successful Australian regional airline with a healthy financial status; it had no outstanding debts and a consistent record of profit margins. Impulse was based in New South Wales, operated a low price, single class service on major competitive trunk routes, Brisbane-Melbourne-Sydney with five Boeing 717-200 aircraft. Impulse aimed to provide a friendly, cheerful, hospitable, no-nonsense country style service (Killian 2001). Moreover, it selected highly competitive routes when it confronted the major incumbent airlines, a strategy usually avoided by new start-up LCCs (Lawton 2002). Furthermore, its fares were no-conditions, fully flexible and fifty per cent lower than Ansett and Qantas (Forsyth 2003). By early 2001, Impulse was experiencing liquidity problems, and by April 2001 Impulse was leasing its aircraft to Qantas (Collins et al. 2010). Under this agreement Impulse would operate services for Qantas under the Qantas brand and terminate its major trunk routes (Forsyth 2003). Qantas acquired Impulse in November 2001 (Collins et al. 2010).

Shortly after Impulse had entered the market, Virgin Blue Airlines was established. Virgin Blue commenced operations in Australia in August 2000 with two Boeing B737 aircraft operating 7 flights per day between Brisbane and Sydney (Thomas 2006b). Virgin Blue was initially owned and founded by the British businessman, Sir Richard Branson (Thomas 2000). Two important features in the second phase of LCCs entry into the market contributed to Virgin Blue's success. First, Ansett Australia ceased operations in September 2001 leaving a very significant capacity shortfall in Australia (Forsyth 2003; Koo 2009). The sudden drop in domestic seat capacity following Ansett's collapse assisted Virgin Blue to expand rapidly with a competitive LCCs' business model (Collins et al. 2010). Secondly, Virgin Blue was in a much more favourable position than its predecessors (Compass I and

⁵ See the following Bureau of Infrastructure, Transport and Regional Economics (BITRE) website for further details of BITRE's air fare collection methodology:
<https://www.bitre.gov.au/statistics/aviation/air_fares_method.aspx>.

Compass II) being part of the international conglomerate, the Virgin Group (Forsyth 2003). In addition, old airport terminal space previously occupied by Ansett was also easily acquired at most airports (Collins et al. 2010). However, the airline sought investors to inject capital in the new airline following the collapse of Ansett Australia in September 2001. Patrick Corporation purchased a 50 per cent stake in Virgin Blue in 2002 (Thomas 2006b). The airline was publicly listed on the Sydney Stock Exchange in 2003 (Thomas 2003; Thomas 2006b).

Toll Holdings bought control of Virgin Blue in 2006 (Knibb 2008a). However, in July 2008, Toll Holdings decided to transfer its 62.7 per cent stake in Virgin Blue to the company's other shareholders. At this time the Virgin Group was the largest single shareholder with a 25.5 per cent stake in the company (Knibb 2008b). In 2004, the airline launched its New Zealand leisure based airline, Pacific Blue, which operated internationally, between Australia, New Zealand, the Cook Islands, Fiji, Tonga and Vanuatu. In 2005, Virgin Blue launched a joint venture airline called Polynesian Blue (Knibb 2005).

In March 2007, Virgin Blue confirmed that they would launch V-Australia, an international airline which would serve leisure travellers between Australia and the United States. To operate this network, V-Australia signed a deal with Boeing for six 777-300ER aircraft (Knibb 2007e). The new airline commenced services on the 28th February 2009 when it commenced operations from Sydney to Los Angeles (Moore 2009). V-Australia was established as part of Virgin Blue's strategy of expanding its range of services to include long-haul international markets, such as the USA (Ionides 2008).

In 2005, Virgin Blue started to reposition itself as a "New World Carrier", following the introduction of Jetstar by Qantas, and to enable it to better compete against both Qantas and Jetstar in the Australian domestic market (Centre for Aviation 2010). Under this strategy, the airline introduced various services LCCs normally avoid. In April 2003, the airline opened airport lounges and this was followed by the introduction of a frequent flyer programme in November 2005 (Collins et al. 2010). In 2008, Virgin Blue introduced a premium economy class in order to attract higher yield business traffic (Collins et al. 2010; Knibb 2007d).

Virgin Blue has expanded its route network beyond linking Australia's capital cities and beyond the traditional tourist routes that link larger coastal tourist destinations, for example, Cairns and Townsville, with the capital cities. The airline's route network strategy has included the addition of routes that were previously only served by regional carriers, for

example, Melbourne to Mildura (Collins et al. 2010). In order to ensure that these thin routes would be economically viable, Virgin acquired a fleet of 24 Embraer E-170 and E-190 regional jets, which carry 76 and 104 passengers, respectively (Collins et al. 2010). The airline also used the Embraer jets to boost flight frequencies on key business routes (Virgin Blue 2006b). In 2008, Virgin Blue introduced a premium economy class in order to attract higher yield business traffic (Collins et al. 2010; Knibb 2007d). In 2011, Virgin Blue announced that it was disposing its fleet of smaller, Embraer E-170 aircraft (Dorman 2011) and replacing them with a fleet of ATR 72 regional turboprop aircraft that will be operated under its strategic alliance with Skywest Airlines (Australian Aviation 2011).

On the 7th December 2011, the Virgin Australia group of airlines officially launched its international airlines V Australia and Pacific Blue under the new brand, Virgin Australia (Virgin Australia 2011b). On the same day, the Virgin Australia group of airlines also unveiled a new brand and livery for its joint venture with the Government of Samoa, Polynesian Blue, announcing that the country's national airline would operate as Virgin Samoa (Virgin Australia 2011b).

Virgin Blue turned out to be the only "native" independent LCCs that survived in Australia's domestic air travel market (Homsombat et al. 2014). The airline adopted a somewhat different business model compared to previous LCCs. For instance, it offered customers connecting services, engaged in code-sharing agreements with major airlines, and was able to sustain airfares significantly lower than those of Qantas (Francis et al. 2006). Most importantly, the collapse of Ansett Australia in 2001 greatly benefited Virgin Blue. The markets previously served by Ansett Australia, which accounted for in excess of 40 per cent of Australia's domestic air travel market, were largely acquired by both Virgin Australia and Qantas (Homsombat et al. 2014). This enabled Virgin Blue to capture in excess of 30 per cent of Australia's domestic air travel market as of early 2003 (Easdown & Wilms 2002).

In response to Virgin Australia's success and aggressive growth, Qantas established Jetstar Airways in 2003, a similar strategy to those implemented by full service network carriers in North America and Europe (Homsombat et al. 2014). Jetstar is a wholly owned subsidiary of the Qantas Group, with Jetstar Airways low fare operations commencing in May 2004 (Collins et al. 2010; Jetstar Airways 2013a). Jetstar began operations with a fleet of 14 Boeing 717 aircraft that Qantas inherited from its acquisition of Impulse Airlines (Knibb 2004a), providing 800 flights a week to 14 destinations around Australia. The airline also decided to operate flights to and from Avalon Airport (an airport located around 55 kilometres

from Melbourne) (Thomas 2007), thus becoming the first Australian carrier to operate from a “secondary city” airport (Qantas 2004).

During 2004, the Qantas Group decided to move Jetstar into a standardized fleet of 177 seat Airbus A320 aircraft (Knibb 2004b). These aircraft provided significant fuel and technology efficiencies and were therefore ideal for Jetstar’s short haul operations. The airline’s original fleet of Boeing 717 aircraft were transferred to QantasLink, a regional airline subsidiary of the Qantas Group (Qantas 2004). Jetstar International was due to receive the first of a fleet of at least 15 Boeing 787 aircraft in August 2008 (Francis & Knibb 2008). The airline’s now operates a fleet comprising 57 Airbus A320, 6 Airbus A321, 7 Airbus A330-200 and 3 Boeing B787-8 aircraft (Jetstar Airways 2013a).

Initially Jetstar’s strategic focus was Australia’s leisure travel market and its services therefore originally focused on linking Australia’s major cities with key holiday destinations (Thomas 2007). As the airline grew, its strategic focus has diverted to linking up Australia’s major population centres (Thomas 2007). The airline later expanded to include international services, commencing services from Brisbane, Gold Coast, Melbourne and Sydney to Christchurch, New Zealand, in December 2005 (Thomas 2007).

In 2006, Qantas decided to launch a low-cost international division, Jetstar International⁶ (Airline Business 2006). Providing a two class service, the Jetstar International services were targeted at the market between single-class low cost and the traditional two-or-three class international carrier services. Jetstar’s international services involved initial stage lengths of between 6 to 10 hours to key Asian and Pacific leisure destinations (Airline Business 2006; Knibb 2006). Following a year of preparatory work, Jetstar International launched long-haul international services in November 2006 with wide-body Airbus A330 services to Bangkok and Phuket in Thailand, followed by services to Ho Chi Minh City in Vietnam and Denpasar, Bali (Ionides 2007a). Services to Honolulu and Osaka in Japan commenced in 2007 as well. Jetstar now operates services to 19 Australian domestic destinations and 17 short and long haul international destinations (Jetstar Airways 2013a).

⁶ Qantas launched Singapore-based Jetstar Asia in 2004, with management rights and with a 44.5 per cent equity stake (Knibb 2007c). Jetstar Asia commenced operations on the 13th December 2005 with services from Singapore to Hong Kong (Ionides 2005). In 2007, Qantas acquired an 18 per cent stake in Vietnam’s Pacific Airlines. Pacific Airlines took the Jetstar name, and converted its fleet from Boeing B737s to Airbus A320s – the same aircraft used by Jetstar and Jetstar Asia (Knibb 2007c; Sobie 2009).

Figure 2.3 shows the annual growth in Australian domestic passengers carried by Jetstar and the concomitant RPKs performed from 2004/05 to 2012/13.

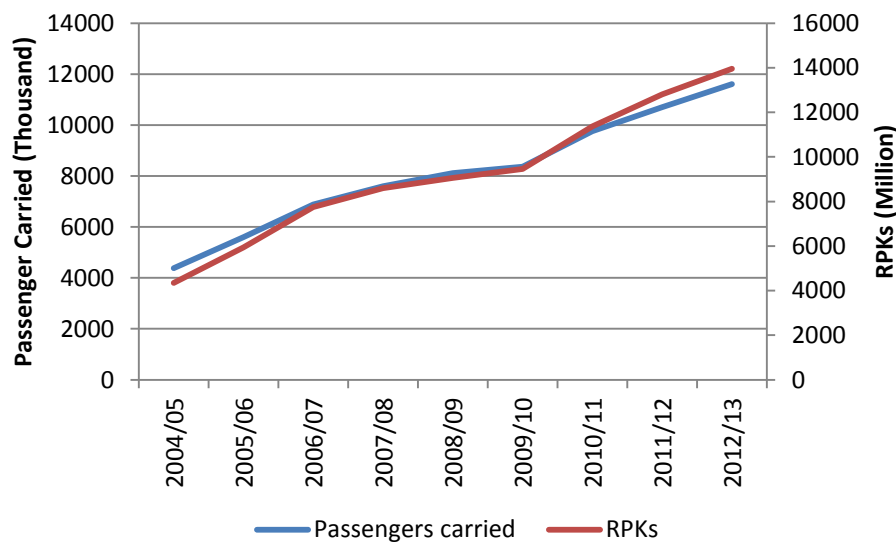


Figure 2.3. Development of Jetstar Australia annual enplaned domestic passengers and revenue passenger kilometres (RPKs): 2004/2005-2012/2013
Source: Qantas Airways (various).

2.3.4 The 'third' wave of LCCs in Australia's domestic air travel market (post-2006)

Singapore-based Tiger Airways launched Tiger Airways Australia in 2007 (Thomas 2006a). Tiger Airways Australian carrier had the same shareholders as the main Singapore-based airline, which meant that the carrier was entirely foreign owned – something that was permissible under Australia's liberal domestic airline ownership regime which permits foreign ownership of a domestic airline (Ionides 2007b; Knibb 2007a). Tiger Airways which was based at Melbourne's Tullamarine Airport, commenced operations with low-cost services to Perth and Darwin, operating a fleet of 5 Airbus A320 aircraft (Koo 2009). Despite their small fleet, Tiger Airways had an impact on Australia's incumbent LCCs, Jetstar, by forcing it to operate services on the same routes as Tiger, as well as providing connecting services to/from Melbourne Airport, a strategy that Jetstar had previously avoided preferring to operate from Melbourne's secondary airport, Avalon (Koo 2009). Tiger Airways arrival into Australia's domestic market also prompted a change to the Qantas long-standing policy as to where Jetstar operated (Knibb 2007b). Prior to 2007, Jetstar avoided operating on route served by Qantas. In anticipation of Tiger's entry into the market, Qantas made a significant change to this policy by allowing Jetstar to compete on the same Sydney-Brisbane route

served by Qantas. Prior to this change, the heavily travelled Sydney-Melbourne-Brisbane triangle was served exclusively by Qantas City Flyer service and by rival Virgin Blue. The bulk of Australia's domestic business travel occurs in this triangle (Knibb 2007b). Tiger Airways currently serves Adelaide, Alice Springs, Brisbane, Cairns, Coffs Harbour, Darwin, Gold Coast, Hobart, Mackay, Melbourne, Proserpine, Sunshine Coast and Sydney (Tiger Airways 2014d).

In November 2011, a new budget airline was launched. Previously a charter business, Strategic Airlines rebranded itself as Air Australia (Nancarrow 2011) Air Australia flew passengers both domestically and to key regional tourist markets. However, in February 2012, Air Australia ceased operations and was placed into voluntary administration (Ironsides 2012; Ryan 2012).

Driven by the strong growth of Virgin Blue and Jetstar, Australia's low cost air travel market sector has been growing rapidly in recent years. As Figure 2.4 illustrates, the LCCs market share grew sharply in 2002 following the entry of Virgin Blue. Such growth momentum was sustained following the entry of Jetstar in 2003 and more or less stabilized since 2005, when the LCCs collectively had captured more than 50 per cent of the total market (Homsombat et al. 2014). The LCCs share of Australia's domestic airline (annual enplaned passengers) peaked in 2010, with a 64 per cent market share. However, over the past 3 years, the LCCs market share has declined to around 31 per cent, primarily due to the change in the Virgin Australia strategy to adopt a FSNC business model.

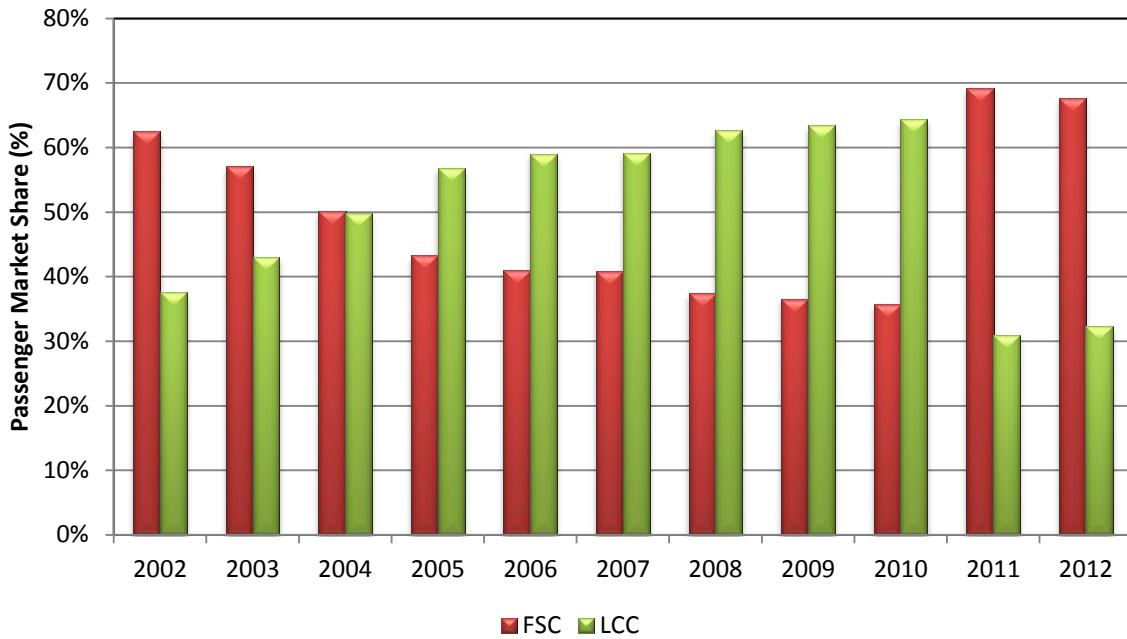


Figure.2.4. Australia's full service network and low cost carrier annual enplaned passengers: 2002-2012

Source: data derived from Bureau of Infrastructure, Transport and Regional Economics (2014b); Qantas Airways (2009, 2013), Tiger Airways (various), Virgin Australia (various).

Figure 2.5 shows the growth in the LCCs Australian domestic market share as measured by revenue passenger kilometres (RPKs), from 2002 to 2012 and highlights the strong growth in RPKs from 2005 to 2010, when the LCC's share peaked at around 57 per cent. From 2011 to 2012 the decline in the LCCs annual RPKs was principally due to the change in Virgin Australia's strategy from moving from an LCC to FSNC business model.

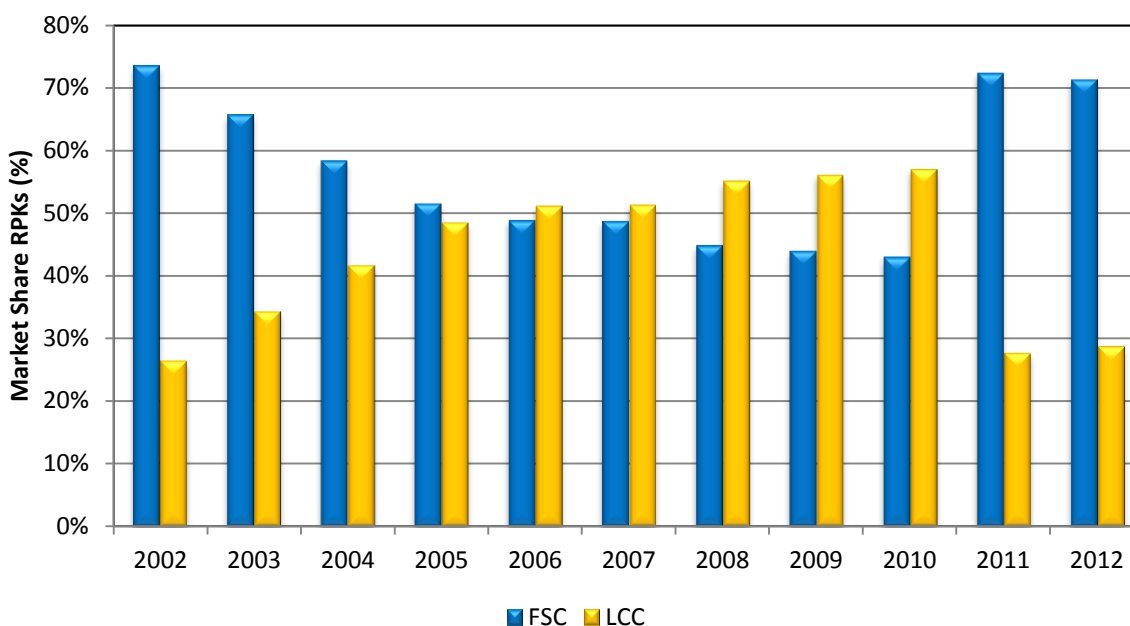


Figure.2.5. Australia's full service network and low cost carrier annual revenue passenger kilometres (RPKs): 2002-2012

Source: data derived from Bureau of Infrastructure, Transport and Regional Economics (2014b); Qantas Airways (2009, 2013), Tiger Airways (various), Virgin Australia (various).

Another significant change which occurred in the third phase of Australia's domestic airline market has been the evolution of the two incumbent airlines: Jetstar and Virgin Australia (previously called Virgin Blue) (Koo 2009). In recent years, Virgin Australia has increasingly focused on becoming a FSNC similar to Qantas. Virgin Australia's business model is focussing on expansion into smaller regional markets with lower levels of demand (markets being served by medium size Embraer aircraft); increasing use of a hub-and-spoke network strategy; introduction of business lounges and premium seating classes; code-sharing and/or interlining arrangements with domestic (for example, REX Express) and international airlines, such as Air New Zealand, Delta Airlines, Etihad and Hawaiian Airlines), and a mixed fleet, including long-haul Boeing 777 aircraft used to operate services to the USA) (Knibb 2008b; Koo 2009). In December 2012, Virgin Australia announced plans to match the Qantas portfolio of domestic airlines by acquiring 60 per cent of Tiger Airways Australia and all of Perth, Western Australia-based Skywest Airlines. Under this strategy Tiger Airways would compete on Virgin's behalf against Qantas LCCs unit Jetstar, whilst Skywest would compete against QantasLink on regional and mining-related routes. In order to fund these acquisitions, and the cost of enhancing these airlines operations, Virgin sold a ten per cent stake in itself to Singapore Airlines. This ambitious initiative formed part of Virgin Australia's re-branding strategy, designed to distance itself from the low-cost carrier sector and compete more with mainline Qantas in the premium business market (Knibb 2012).

Virgin Australia's strategic repositioning continues to attract shareholder interest with Singapore Airlines strengthening its cooperation and equity investment in the carrier. Together with the 10 per cent shareholding acquired in November 2012, Singapore Airlines now holds a 19.9 per cent stake in Virgin Australia (Taylor 2013). On June 17, 2014, Air New Zealand increased its shareholding in Virgin Australia to 25.5 per cent. Etihad Airways and Singapore Airlines also held stakes of 21.24 per cent stake and 22.17 per cent at that time, respectively (Freed 2014). Figure 2.6 shows the annual growth in Australian domestic passengers carried and revenue passenger kilometres (RPKs) performed by Virgin Australia from 2002 to 2013.

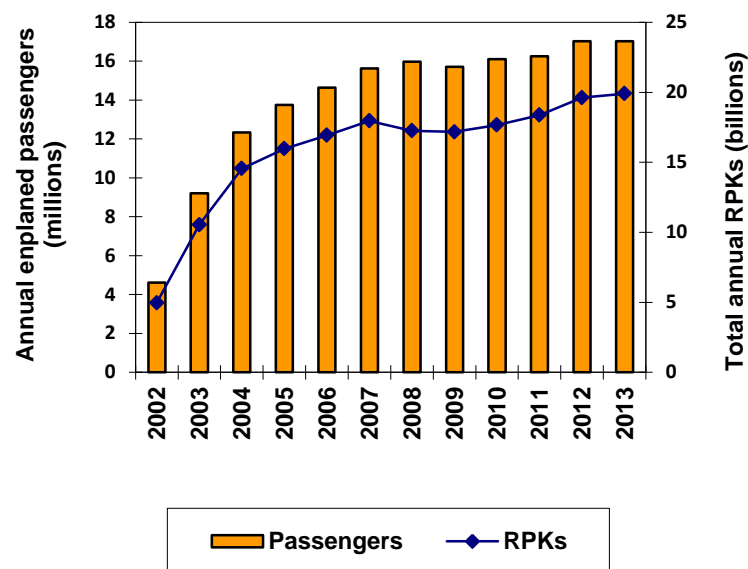


Figure 2.6. Development of Virgin Australia enplaned passengers and revenue passenger kilometres (RPKs): 2002-2013.
Note: 2002 data for 9 months.
Source: Virgin Australia, Virgin Blue (various annual reports).

Currently, two LCCs dominate Australia's domestic air travel market: Jetstar Airways and Tiger Airways. Jetstar Airways now forms an integral part of the Qantas Group's two-brand strategy. The airline primarily operates in leisure and value-based market segments (Jetstar Airways 2013a). The dual Qantas Group brand strategy has resulted in the group capturing a significant market share (Homsombat et al. 2014).

2.4 Summary

This chapter has presented an overview of the development of Australia's domestic low cost air travel market and has traced changes in Australian government domestic airline policy, as it evolved from a tightly regulated to a deregulated market policy setting which enabled LCCs to enter the market.

This chapter also examined the evolution of LCCs in Australia's domestic air travel market and showed that since the market was deregulated on the 30th October 1990, the LCCs market has passed through three discrete phases. The first wave of LCCs entered the market between 1990 and 1993. During this phase, several LCCs – Compass and Compass Mark II – commenced business, but both subsequently failed within a year of starting operations. During the period from 1994-1999, a duopoly encompassing Ansett Airlines and Qantas emerged in Australia's domestic air travel market (Koo 2009).

The second wave of LCCs – Impulse Airlines and Virgin Blue – entering the market occurred between 2000 and 2006. The third phase in the evolution of Australia's domestic LCCs air travel market occurred in the post-2006 period. In 2007, Singapore-based Tiger Airways established Tiger Airways Australia, with a small fleet of Airbus A320 aircraft. Since 2011, Virgin Australia's has changed from an LCC to a FSNC business model, similar to that of Qantas. A further feature of the third phase of Australia's LCCs evolution has been the focus of incumbents on establishing long-haul international operations. Jetstar International, was launched in 2007, with long-haul, low-cost services from Australia to Honolulu, Hawaii, Japan and Thailand.

The LCCs market share grew sharply in 2002 following the entry of Virgin Blue. LCCs share of Australia's domestic airline (annual enplaned passengers) peaked in 2010, with a 64 per cent market share. However, over the past 3 years, the LCCs market share has dropped to around 31 per cent, primarily due to the change in the Virgin Australia strategy to adopt a FSNC business model. Jetstar and Tiger Airways are currently the two major domestic incumbent Australian LCCs.

Chapter 4 presents an overview of the LCC business model, and highlights the evolution of Australia's domestic LCCs' business model to a *hybrid* model, a practice that has become increasingly common with other LCCs around the world

CHAPTER THREE: ANALYSING LOW COST CARRIERS IN AUSTRALIA'S DOMESTIC AIRLINE MARKET

3.1 Introduction

There is an extensive body of literature that has focused on LCCs' business models. It is therefore necessary to examine the relevant theories, as they provide an understanding of the LCCs' business model, and are highly relevant to this study.

In recent times, Australia's LCCs' business models have evolved in response to changing market requirements, and this has led to the development of a new hybrid LCCs' business model (Section 3.4).

This chapter is arranged as follows: Section 3.2, which provides a definition of a LCC, identifies the key differences between the LCCs' and full service network carriers' business models. Section 3.3 presents an overview of the LCCs' business model, and its key characteristics. Section 3.4 examines the key characteristics of Australia's LCCs.

3.2 Low Cost Carriers: Key Definition

Low cost carriers (LCCs) are an airline that offers low air fares but eliminates all unnecessary services or making some available at an extra optional cost, for passengers (Doganis 2006).

Table 3.1 highlights the differences between the low cost and full service network carriers.

Table 3.1. Comparison of low cost versus full service network carriers key attributes

Low Cost Carriers	Full Service Carriers
<ul style="list-style-type: none"> • Simple brand 	<ul style="list-style-type: none"> • Complex brand
<ul style="list-style-type: none"> • Online and direct booking 	<ul style="list-style-type: none"> • Mainly travel agents
<ul style="list-style-type: none"> • Simple fare structure and ticketless check-in 	<ul style="list-style-type: none"> • Complex fare structures
<ul style="list-style-type: none"> • Use of secondary airport 	<ul style="list-style-type: none"> • Focus on primary airports
<ul style="list-style-type: none"> • High aircraft utilization - quick turnaround time 	<ul style="list-style-type: none"> • Lower utilization on short haul

<ul style="list-style-type: none"> Do not interline/point to point service 	<ul style="list-style-type: none"> Interlining important part of service
<ul style="list-style-type: none"> Simple product – all additional services and facilities charged for, e.g. credit card bookings, late check-in 	<ul style="list-style-type: none"> Complex integrated service products, e.g. ticket flexibility, business lounges, frequent flyer programme
<ul style="list-style-type: none"> Focus on ancillary revenue generation advertising ('the plane as a billboard'), on-board retailing 	<ul style="list-style-type: none"> Focus on primary product
<ul style="list-style-type: none"> Mainly short-haul focus 	<ul style="list-style-type: none"> Short and long-haul
<ul style="list-style-type: none"> Common fleet type acquired at very good rates 	<ul style="list-style-type: none"> Mixed fleet

Source: adapted from Lawton (2002, p.38).

3.3 Low Cost Carrier Business Model and Key Characteristics

Low cost carriers' focus on cost reduction. This strong focus on cost mitigation enables them to implement a price leadership strategy in the markets in which they operate (Vidović et al. 2013). The LCCs' business model is very simple: operate at the lowest possible cost and sell seats at low rates, such that they stimulate demand, and achieve high load factors (Fernie 2011).

3.3.1 Provision of a 'no-frills' service

Historically, one of the most self-evident examples to consumers of the difference between LCCs and FSNCs⁷ was a 'no-frills' service. In the United States, for example, passengers travelling on a FSNC service would often receive a hot meal with an extensive beverage service, whilst in contrast, passengers travelling on Southwest Airlines (an LCC carrier), would receive peanuts and a soft drink. However, in recent times in the U.S., following cost-cutting initiatives by the FSNCs, all-economy class service has turned into a 'no-frills' service as well (Vasigh et al. 2013). In Australia, the LCCs – Jetstar and Tiger Airways – have gone one step further where everything, including food and beverages, is on a purchase-onboard basis. This is a similar strategy to that of the major European LCCs, such as Ryanair.

⁷ A "full service network carrier" is an airline that focuses on the provision of a wide range of pre-flight and on-board services, including different classes of service, and connecting flights (Ehmer et al. 2008).

Consequently, the in-flight service food and beverage service that used to distinguish the difference between LCCs from 'full service' carriers is often no longer applicable (Vasigh et al. 2013). In addition, LCCs often eliminate the provision of in-flight entertainment (IFE) systems in order to minimise their costs (Doganis 2006; Homsombat et al. 2014).

The underpinning premise behind the LCCs no-frills strategy is 'ultimately a passenger pays as goes' approach, where the ticket price (air fare) entitles the passenger to just a seat on the aircraft. Because of this strategy, LCCs are able to offer attractive air fares (Vasigh et al. 2013).

However, for the LCCs, no-frills service is not just restricted to in-flight service. Many LCCs do not offer frequent flyer programs or costly airport business lounges (Cento 2009); these amenities are not offered, in order to reduce airline costs. A further cost-cutting initiative recently implemented by the LCCs was the restriction on passenger luggage allowances. Especially in Europe, the LCCs have very stringent rules concerning passenger baggage allowance weights; this strategy is designed to conserve aircraft fuel and to generate additional marginal revenue (Vasigh et al. 2013).

3.3.2 Point-to-point (P2P) airline route networks

Following deregulation, many FSNCs have adopted a hub-and-spoke route network structure. Airline hub-and-spoke route networks are comprised essentially of routes (spokes) to and from one or more major airport selected by the airline to serve as hubs. The flight schedules are coordinated to operate in "banks", or complexes, throughout the day, in order to optimize the number of possible passenger connections. Typically, connecting passengers constitute a sizeable proportion of hub-and-spoke network traffic (McKnight 2010). Whilst the hub-and-spoke route network system has proved effective for the FSNCs in providing a wide range of origin-and-destination (O & Ds) connections, they are costly to operate (Vasigh et al. 2013). Hubs typically have peaks so as to minimize passenger connecting times, but also considerable down times where the carrier is not fully utilizing its assets and facilities (Vasigh et al. 2008).

Despite the undoubted revenue benefits of offering extensive origin-and-destination (O & Ds) connections as well as the ability to increase load factors, one of the main cost benefits underpinning a hub is the airline's ability to realize certain economies of scale. Consolidating

operations at a single airport reduces fixed overheads such as required staff pools, maintenance operations, and airport terminal-related costs. The problem for airlines operating hub airports is that the peaks scheduling required for passenger convenience also means that these economies of scale are not always realized. Furthermore, once the level of flights reaches a critical level, diseconomies of scale will occur, that is, any additional flight will in fact increase average costs rather than reduce them – because the added congestion at the airport increases costs (Vasigh et al. 2008). For instance, as the airport becomes busier and busier, aircraft are required to wait for longer periods of time before they can land or take-off, which increases both fuel and staff costs (Vasigh et al. 2013).

The prevalence of the diseconomies of scale previously mentioned is one of the principal reasons why LCCs operate a point-to-point (P2P) or origin-and-destination (O & D) route network structure (Vasigh et al. 2013). With a point-to-point (P2P) route network structure, passengers are normally able to travel directly between their desired city pairs (O & Ds) that are serviced by the airline's P2P network (Wu 2010). A linear route point-to-point airline tends to focus its services on dense markets with sufficient origin and destination traffic to sustain non-stop operations (Dempsey & Gesell 1997). Also with a P2P network structure, airlines will still operate key bases where economies of scale can be achieved, but may not always have peak levels of flights. This enables the airline to continuously utilize its airport facilities and equipment and more evenly use its employee services. This enhanced utilization of airport assets enables a P2P airline to operate more flights with fewer facilities and employees, and this ultimately reduces their costs (Vasigh et al. 2013).

The LCCs business model is therefore often based around very short distance, point-to-point sectors (Alamdari & Fagan 2005). The operation of short-haul, point-to-point services enables the LCCs to operate a high number of daily flight frequencies in each direction (Alamdari & Fagan 2005; Koch 2010). By significantly reducing costs and air fares, the LCCs have successfully opened up a much broader range of point-to-point services, many not served by the FSNCs, and in so doing have captured at least some of the price-conscious passengers from the higher-priced FSNCs (Hunter 2006). The LCCs also do not typically operate complex aircraft rotations or itineraries. Rather the aircraft operate between their home base and their destinations (Koch 2010).

In the United States, Southwest Airlines, for example, generally operates a P2P route network structure, and a good number of their passengers often connect on Southwest flights through some of Southwest's larger bases (Vasigh et al. 2013). In Europe,

Dobruszkes (2006) observed that post-deregulation airline route network patterns have largely been induced by the LCCs. He noted that the European airline networks have evolved from a 'radial' to a 'star-shaped' pattern following the proliferation and success of Ryanair and Easyjet. Koo (2009) suggested that while not as spatially comprehensive as that of either Europe or the United States, the Australian LCC's carrier's route networks broadly resembles the P2P network structures of the U.S, and Europe. Sinha (2001) has also demonstrated that the Australian LCCs networks are mostly P2P in structure because they have a high level of demand concentration on a few large nodes, that is, the demand is largely concentrated between Australia's state and territory capital cities (Koo 2009).

3.3.3 Operating short-haul services and homogenous aircraft fleets

An airline's fleet size and fleet structure have a substantial impact on its operating costs (Klophaus et al. 2012). LCCs costs are therefore minimized by operating a single-type aircraft fleet (Koch 2010). The use of a young and homogenous fleet of medium-sized aircraft (usually Boeing 737-700/800 or Airbus 320 aircraft) normally results in a reduction of fuel, maintenance, staff costs and – if large orders at discounted prices are placed – capital costs (Ehmer et al. 2008; Vasigh et al. 2013). A fleet commonality strategy provides LCCs with a number of important advantages:

- greater flexibility for an airline's cockpit and cabin crews;
- standardizes the requirement for ground servicing equipment;
- leads to lower maintenance costs; and
- reduces the airline's training requirements and costs (Alamdari & Fagan 2005).

However, it is the economies of scale that are the most important cost elements underpinning an airline's common aircraft fleet-type strategy. That is, the airline incurs its fixed fleet costs only once. For example, the ground servicing equipment required to support a Boeing B737 aircraft is only acquired once (Vasigh et al. 2013).

A further benefit of a common aircraft fleet strategy is greater operational flexibility. In the case of disrupted operations, a single aircraft type often makes it easier for the airline to

locate a replacement aircraft or usually, and critically, replacement crews⁸ (Vasigh et al. 2013).

A single aircraft fleet strategy does however have advantages and disadvantages. Depending upon the aircraft selected by the airline, the aircraft may not be the optimal aircraft for some markets. Hence, if the aircraft only has a short-range capability, inter-continental or longer-haul services will not be feasible. In contrast, as we have previously noted, a single aircraft fleet have the same flight crew and maintenance requirements. For LCCs, the two most widely used aircraft types are the Airbus A32X and the Boeing B737NG. Both of these aircraft types enable LCCs to operate aircraft with as few as 120 seats and up to 200 seats. This seating flexibility enables the LCCs to be better able to change seating capacity to satisfy demand on any given day (Vasigh et al. 2013).

Irrespective of the aircraft type operated, LCCs configure their aircraft with a high density, all-economy seating configuration. Some LCCs have also removed closets and toilets from the aircraft, whilst others such as Ryanair do not offer reclining seats in order to accommodate more passengers on their aircraft (Vasigh et al. 2013). LCCs unit costs are therefore also reduced by implementing a high density seating configuration (Doganis 2006).

3.3.4 Use of secondary airports

The LCCs often operate services from secondary airports (Chang & Hung 2013; Francis et al. 2006). These airports are normally located farther from the main urban area than primary airports (Ehmer et al. 2008). Apart from the lack of congestion at smaller airports, secondary airports usually charge lower fees than the more established airports and, where permitted, are more willing to co-finance the promotion of new routes (Barbot 2006; de Wit & Zuidberg 2012).

The use of secondary airports, LCCs are able to not just reduce their costs, but also capture competitive advantage. Firstly, the use of secondary airports enables LCCs to overcome any slot availability problems. This enables LCCs to design flight schedules that optimize their aircraft utilization (Barbot 2006). Nevertheless, lower air fares are crucial, however, because the accessibility to and from these often quite remote, secondary airports can be quite time consuming for passengers, which may make the LCCs services quite unattractive to time-

⁸ Since airlines typically have a reserve flight crew contingent for each aircraft type, restricting the number of aircraft types operated therefore limits the number of flight crew that the airline requires (Vasigh et al. 2013).

sensitive business passengers (de Wit & Zuidberg 2012). Accordingly, lower air fares need to be offered by the LCCs in order to attract sufficient price-sensitive passengers from larger traffic catchment areas (Pantazis & Liefner 2006).

Aircraft ground handling⁹ turnaround times and flight delays are also reduced by serving smaller, uncongested airports and by focusing on point-to-point flights (Koch 2010; Pitt & Brown 2001). This strategy enables LCCs to optimise the number of daily aircraft block hours, and hence, aircraft utilization rates (Ehmer et al. 2008). Successful LCCs also avoid operating from airports with congested airspace, runways, and taxiways (de Neufville 2006). Less congested secondary airports help airlines to maintain their flight schedules and avoid delay costs (Fernie 2011). By utilizing less congested airports aircraft turnaround times can be optimized which helps the LCCs to keep their costs low, while also increasing the airline's operational efficiency and productivity. This is important because quick turnaround times enable LCCs to maximize aircraft use and minimize the time they are on the ground (Barrett 2004; Gillen & Lall 2004; Vasigh et al. 2013) and operating from airports with low levels of delays results in significant cost advantages for the LCCs (de Neufville 2008). Indeed, one of the key success factors of the LCCs business model is the high daily aircraft utilization rate¹⁰ and rapid ground handling turnaround times (Goh 2005; Thanasupsin et al. 2010), which are very often less than 20 minutes in duration (Bieger & Agosti 2005). However, whilst airport slot times and aircraft turnaround facilities are important determinants of choice for LCCs, adequate demand in the market is the most important factor. As a result, LCCs tend to favour entry on routes with dense demand (Koo 2009).

Furthermore, LCC's often use a "free seating" policy, since it encourages passengers to board quickly and thus helps them to avoid flight delays (Ehmer et al. 2008; Vasigh et al. 2013). Notwithstanding, even if secondary airports have dominated the LCCs route network strategies, in recent years primary airports have slowly entered into their route systems. Thus, a number of LCCs have now tended to adopt a mixed airport strategy, with many LCC's basing their operations at prime hub airports. The LCCs operate services from these hubs to secondary, spoke airports (Alamdari & Fagan 2005).

⁹ When aircraft are on the ground in between flights they require various ground handling services to be performed, for example, aircraft loading/unloading; air cargo handling; lavatory services, and aircraft towing or pushback (Kazda & Caves 2007).

¹⁰ The downside to increased aircraft utilisation rates is the increase in aircraft maintenance costs since the aircraft are flying more often. This is a trade-off that many LCCs are prepared to accept (Vasigh et al. 2013).

LCCs are also able to reduce costs by avoiding airports that have expensive ground facility rents. LCCs often use older, less expensive terminal facilities, and, most importantly, optimize their terminal space more intensively so that they require less. LCCs also pay attention to their customers' car parking costs and other associated airport fees (de Neufville 2006).

3.3.5 Simplified pricing and low cost distribution optimization

The LCCs pricing policy is very dynamic in nature (Doganis 2006). A key part of the LCCs pricing policy is that they offer substantial discounts for tickets that are booked by passengers well in advance. This strategy often generates new demand from passengers, usually low-yielding, which may not have flown otherwise (Ehmer et al. 2008; Vidović et al. 2013). LCCs offer single, unrestricted, and point-to-point air fares (Homsombat et al. 2014).

The LCCs also focus on low-cost distribution channels (Flenskov 2005; Koch 2010) with distribution and sales costs being kept at a minimum by the use of internet sales, proprietary boarding control, and limited marketing budgets (Katarellos & Koufodontis 2012). The use of internet technologies has enabled the LCCs to reduce their distribution costs¹¹ by bypassing intermediaries, such as travel agents (Koo 2009). One important strategy employed by the LCCs is to initially align themselves with multiple global distribution service (GDS) providers and then, as their brand awareness becomes stronger, to slowly conclude their agreements with their GDS providers. This permits the LCCs to have a broad distribution system initially and then narrow its distribution system (and its costs) as it pushes ticket sales towards its website (Vasigh et al. 2013). Europe-based Ryanair was very successful with such a strategy (Field & Pilling 2005, cited in Vasigh et al 2013).

3.3.6 Focus on ancillary revenues

Ancillary revenues are an important revenue stream for the LCCs. These revenues come from the sale of other products and services both on board the aircraft and through their websites (Doganis 2009; Francis et al. 2007). According to de Wit and Zuidberg (2012, p.21), "the unbundling of the traditional all-inclusive airline product and the provision of unbundled low air fares can assist airlines in attracting price-sensitive passengers to their

¹¹ LCCs typically do not rely on intermediaries such as travel agents and global distribution systems (GDS) to sell their tickets; rather they aim to sell their tickets via their website (Klophaus et al. 2012; Vidović et al. 2013).

secondary airports from even greater distances away, and they are also able to compete more effectively against the FSNC for higher yielding passengers at the major airports”.

However, in recent times, certain features of the original LCCs’ business model have been discontinued or radically changed in response to the evolving market conditions (Alamdari & Fagan 2005). This model appears to be evolving due to the changing environment, and a new model is appearing, such as the new long-haul low cost model (Daft & Albers 2012; Morrell 2008; Wensveen & Leick 2009). AirAsiaX and Jetstar Airways are successful examples of this model.

As noted earlier, the basic LCCs’ business model is based on low cost leadership and the core product of operating services from Point A to Point B (Koch 2010). LCCs concentrate on the provision of the core air transport service by omitting any costly service features and through the optimization of the entire process chain from the distribution to (ground and in-flight) operations due to their low costs structure (Klaas & Klein 2005). By having a low cost structure, LCCs are able to provide consumers with lower price services (Doganis 2006). By cutting costs to the absolute minimum, LCCs can make a profit at much lower prices than their competitors as long as pricing can stimulate demand. Lower fares create demand in two ways: by winning share of the existing travel market from customers motivated by price, and by stimulating new demand from customers who travel by bus or rail or who have never travelled before (Fernie 2011). This has led many price sensitive consumers to switch from legacy carriers to the LCCs (Flouris & Oswald 2006; Mason 2001). Moreover, the lower prices offered by LCCs have stimulated traffic between city pairs where consumers would not otherwise have flown if there not been an offer of lower fares by the LCCs (Lall 2005). This has allowed LCCs to gain larger market shares.

3.4 The Hybridization of Australia’s Domestic Low Cost Carriers Business Models

The preceding section has presented a review of the extant literature on the key characteristics of the generic LCCs’ business model. However, in recent times the business models of many LCCs around the world have been evolving into what has been termed a ‘*hybrid*’ model (Tomová & Ramajová 2014; Vidović et al. 2013). In the context of the present study, this raises two important questions: *What are the key characteristics of Australia’s current LCCs’ business models?* and *Have Australia’s LCCs’ business models pursued a*

hybridization strategy? In light of these important questions¹² and the trend towards hybridization of LCCs' business models around the world, an important aim of this thesis was to examine whether Australia's domestic LCCs are following similar business model hybridization strategies. The following section therefore examines this issue in detail with the aim being to provide a greater understanding of how Australia's domestic LCCs are strategically responding to the changing market's requirements.

3.4.1 Australia's low cost carrier's service and product offerings

Historically, most LCCs did not offer a frequent flyer program (FFP) as they preferred to compete on the basis of low air fares. Nonetheless, as airline business models have evolved in recent times, both from the LCCs model to the FSNC approach and vice versa (Centre for Aviation 2013; Tomová & Ramajová 2014), it has now become quite common for LCCs to include loyalty schemes in their product offering. Indeed, there is a growing recognition that such loyalty schemes do not always result in higher costs and that they can drive additional ancillary revenues for LCCs. Furthermore, a number of LCCs have concluded partnership agreements with FSNCs and reciprocal FFP recognition can assist the development of such relationships (Centre for Aviation 2013).

Jetstar Airways has reciprocal frequent flyer program arrangements with its parent company Qantas. These arrangements enable Jetstar's passengers to enjoy the benefits of the Qantas Frequent Flyer program. Under these arrangements a Qantas Frequent Flyer member can earn Qantas Points and Status credits when travelling on Jetstar services. Similarly, Jetstar passengers are able to earn points and status credits when travelling on an "Economy Starter Plus" or "Max fare" with Jetstar (JQ), Jetstar Japan (GK), Jetstar Asia (3K) or Valuair (VF). Jetstar's "Business Max" fares also earn Qantas Points and Status credits at the same rate as Economy fares (Jetstar Airways 2013c).

On the 8th April 2014, Tigerair Australia officially launched its '*Infrequent Flyer Club*', a new online club for Australians who do not fly as frequently as they would like but who still wish to participate in a frequent flyer scheme (Tiger Airways 2014c). The Tigerair '*Infrequent Flyer Club*' offers a member regular updates on travel deals. The new club also rewards

¹² To address these two critical questions, the following analysis follows the approach proposed by Bowen (2009). Document analysis is a systematic procedure for reviewing or evaluating documents—both printed and electronic (computer-based and Internet-transmitted) material. Further details of this approach can be found in Bowen (2009). A summary of the documents selected and the subsequent data analysis are presented in Appendix 1 Table A1).

passengers for flying with Tigerair. The *Infrequent Flyer Club* is fundamentally a customer relationship management (CRM) platform that enables Tigerair to keep its Infrequent Flyers up-to-date with the airline's special deals and promotional opportunities. Unlike frequent flyer schemes where new members commence with a bronze status and then progress to higher levels based on patronage, Tigerair's Infrequent Flyer Club permits members to select whatever level they want from 70's brown through to triple emerald sapphire ivory (Tiger Airways 2014c).

LCCs usually offer simple products. However, in order to capture revenue, LCCs charge extra fees for the additional services and facilities provided to their customers. In December 2009, Jetstar introduced '*Up Front Seating*' (which uses the first three rows of economy class), for passengers who prefer sitting close to the front of the aircraft so that they can board and deplane the aircraft more quickly. Passengers wishing to take advantage of this arrangement are charged for \$5 per sector on Jetstar's domestic services (Australian Aviation 2009).

Jetstar have also introduced three types of air fares: Starter, Plus bundle and Max bundle. These bundle options provide passengers with greater choice and flexibility with the different airfare. For example, *Starter* fare includes just the seat and a 10kg carry-on baggage allowance. By adding 'Plus' option, passengers will be able to earn Qantas frequent flyer points and status credits, free standard seat selection, and a waiver of change fees. Passengers opting for the *Max* bundle in addition to the *Plus* fare features receive extra leg room and/or seating at the front of the cabin, plus air fare refund ability. These also help Jetstar to increase its revenue (Australian Aviation 2011c).

In May 2011, Jetstar introduced airport self-service kiosks and web check-in for passengers. These enable passengers to "pre-enrol" for check-in. Passengers may receive either an SMS boarding pass or boarding pass via their email account 24-hours before their departure. This product feature enables passengers to reduce their time spent at airports, and also reduces Jetstar's costs (Australian Aviation 2011d).

In March 2014, Tigerair Australia began offering a web check feature which allows passengers to check-in online for their flight(s) up to 72 hours prior to their flight departure. Passengers are also able to print their own bar-coded boarding pass, which enables them to bypass the traditional check-in queue and speeds up the baggage drop process for those passengers with checked luggage (Australian Aviation 2014b).

3.4.2 Australia's low cost carrier's route network structures

As we have previously noted, Sinha (2001) has also reported that the Australian LCCs networks are mostly point-to-point service (P2P) in structure because they have a high level of demand concentration on a few large nodes, that is, the demand is largely concentrated between Australia's state and territory capital cities (Koo 2009).

Figure 3.1 presents Tigerair Australia's domestic airline route network and shows that the airline serves both key business markets, for example, between Melbourne and Sydney, and Australia's major tourist or leisure markets.

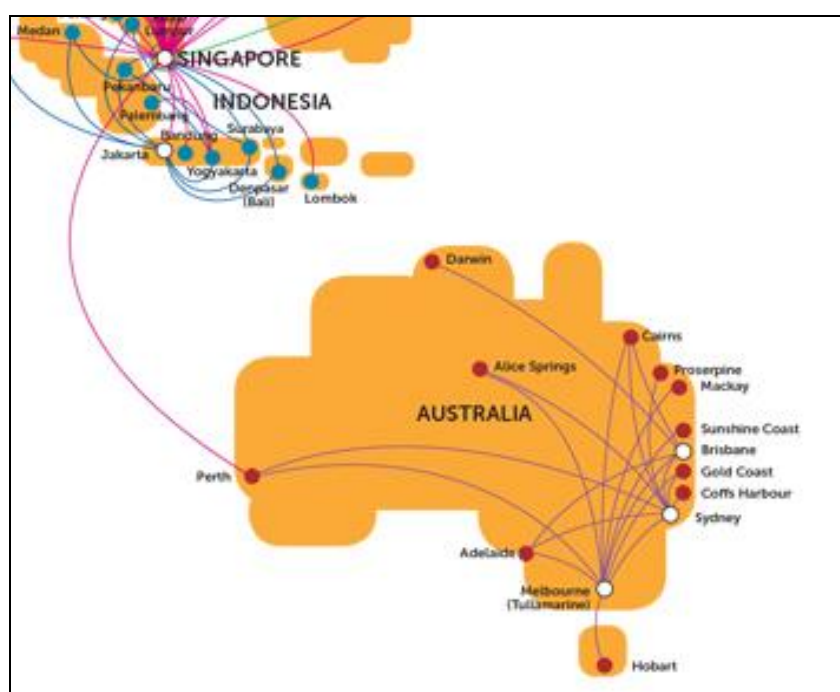


Figure 3.1. Tigerair Australian domestic airline network
Source: Tiger Airways (2014d).

Jetstar commenced services in 2004 operating short haul Australian domestic point-to-point services. Jetstar commenced long-haul international services in 2006 (Qantas Airways 2013). On 23 December 2006, Jetstar first international long-haul services to Bangkok was introduced while Phuket, Ho Chi Minh city, Osaka, Bali and Honolulu have subsequently been added to the airline's international route (Qantas Airways 2013; Thomas 2007). In the 2012/2013 financial year, Jetstar Airways 57 per cent of its business was derived from its domestic Australian operations, with the remaining 43 per cent being earned from its

international operations (Qantas Airways 2013). Jetstar further aims to increase its Asian network as part of the airline's so called "Pan Asian Strategy".

A principal feature of the traditional LCCs' business model is the use of secondary airports (Section 3.3.4 above). When Jetstar commenced operations in 2004, the airline decided to operate services from Avalon Airport, a secondary airport, located around 55 kilometres from Melbourne. The profitability of operating services from Avalon Airport has proved difficult. Consequently, Jetstar have reduced services at Avalon Airport in order to focus their services on Australia's major airports (Australian Aviation 2013). In December 2013, Jetstar confirmed it was reviewing its Avalon services as they were considered to be under-performing. However, contributions of \$AUD 5.5 million from the Victorian Government and \$AUD 2.75 million from both Linfox, the company that operates the airport, helped avert its departure from the airport (Lannen 2014).

LCCs do not generally join strategic airline alliances. Recently, Jetstar and Emirates Airline announced an agreement to codeshare¹³ on a number of different services. This will increase an opportunity for Jetstar to drive domestic tourism destinations, such as, Hamilton Island, Byron Bay and Uluru. Jetstar have also ratified code-sharing agreements with several airlines such as American Airlines, Jet Airways, Japan Airlines, Finnair and Air France – KLM. In addition, Jetstar has air fare agreements with the oneworld global airline alliance. Consequently, Jetstar services are saleable by oneworld alliance member airlines and travel agents. These arrangements provide Jetstar with a global presence (Australian aviation 2010; Australian aviation 2011a; Australian aviation 2012; Australian aviation 2014a)

3.4.3 Australia's low cost carrier's aircraft fleet structure

In terms of aircraft fleet type, Australia's current two LCCs are basically adhering to the generic LCCs' business model by operating a homogenous fleet of the Airbus A32X family aircraft on their Australian domestic services (Table 3.2).

¹³ A *code-share* is a partnership agreement between two airlines: the operating airline and the marketing airline (Abdelghany & Abdelghany 2009, p. 221), under which the flights of the two participating airlines occur on a single airline. The flights are displayed in such a way that airlines are responding to consumers' preferences for booking flights on the same airline (Diederiks-Verschoor 2006).

Table 3.2. Comparison of Jetstar and Tigerair Australia Airbus A320 key characteristics

	Jetstar	Tigerair
Number in fleet	57 (JQ)	13 ¹
Seating configuration	180 All leather seats 17.88 inches wide and with an average seat pitch of 29 inches	180
Maximum Take-off Weight	77,000 kg	Not available
Range With Full Payload	4,800 km	Not available
Engines	2 x V2527-A5 International Aero Engines (IAE)	Not available

Source: Jetstar Airways (2013b); Tiger Airways (2014b).

Note:

1. Fleet as 31st May 2014.

In addition to its extensive fleet of Airbus A320-200 aircraft, Jetstar also operates a small fleet of six Airbus A321 aircraft. These aircraft are seat configured to accommodate 220 passengers. In addition to the larger seating capacity, these aircraft also have a longer range capability (5,600 km) than the airline's Airbus A320 aircraft (Jetstar Airways 2013b).

Jetstar commenced operations in 2004 with a fleet of Boeing B717s (Thomas 2004). From 2004 to 2006, Jetstar gradually changed to a single Airbus A320 fleet type. In June 2006, the airline operated 23 A320s aircraft (Creedy 2005; Ionides 2007; Thomas 2004). The bigger Airbus A320 aircraft, which were powered by International Aero Engines V2500 engines, allowed Jetstar to reduce frequencies on some leisure routes and redeploy the aircraft to new destinations (The Saigon Times Daily 2003).

As Table 3.2 shows, Jetstar has adopted a strategy of principally operating Airbus A320 aircraft in its domestic Australian route network. The carrier also operates several Airbus A321 aircraft in Australia. Jetstar also has its own line and heavy maintenance operations for A320 at Jetstar's Newcastle maintenance base (Qantas Airways 2012).

Tiger Airways has followed the 'traditional' LCCs' business model by operating a single, homogenous aircraft fleet type – the Airbus A320 aircraft. As at the end of August 2014, Tiger Airways operates a fleet of 13 Airbus A320 aircraft throughout Australia (Table 3.2).

3.4.4 Australia's low cost carrier's pricing and distribution strategies

As noted above LCCs' pricing policy is to offer heavily discount fares for air travel booked long in advance in order to stimulate demand (Doganis 2006).

When Jetstar first commenced operations in 2004, the airline offered an introductory seat sale of \$29 for 200,000 seats. In January 2005, Jetstar offered substantially discounted air fare of \$9 plus taxes on 15 routes such as Sydney - Sunshine Coast and Sydney - Gold Coast for 300,000 seats (Creedy 2004).

In 1 October 2004, announced conditional internet \$49 one-way fares on some routes such as Sydney-Launceston, Melbourne- Hobart and Newcastle-Melbourne or Brisbane and \$79 one-way fares for Sydney- Rockhampton, \$89 Sydney-Whitsunday Coast and \$119 Sydney-Hamilton Island under the condition that fares were available for travelling between 23 October and 16 December 2004 and January to 28 February 2005 (Thomas 2004).

Jetstar has aimed to be the lowest fare operator in the domestic market (Owen-Browne 2003 cited in Whyte & Prideaux 2007). In February 2008, Jetstar offered discount airfares to passengers travelling with no check-in luggage. This initiative was designed to enable Jetstar to obtain a price advantage over competitors (Flight international 2008).

From its inception of operations in Australia in 2005 Tigerair Australia, has also focused on providing very low air fares in the Australian market, in order to stimulate demand (Lindsay 2007). In June 2012, Tigerair Australia offered domestic half price air fares, for example, Melbourne –Sydney route from \$29.95. A similar initiative was offered in October 2012, when the airline offered 30 per cent off the regular Tiger “Raw” domestic airfares on three popular route; Melbourne – Sydney, Melbourne – Hobart and Sydney – Gold Coast for 30,000 seats (Singapore Government News 2012). .

LCCs' business models encourage direct booking via their own website in order to reduce travel agent cost. Tigerair, however, in January 2014, collaborated with Amadeus travel agencies, a leading technology partner for the global travel industry, to utilise the Amadeus distribution channel via travel agencies. This system provides a simple and seamless way for Tigerair to distribute its full range of attractive fares and content via an extensive network of travel agencies located throughout the Asia Pacific region. These travel agencies can make bookings easily using a web-like interface. Tigerair ancillary sales such as advance boarding, seat selection, luggage and other passenger amenities are able to be booked through this system. It was expected that this strategy will strengthen their distribution channel (Tiger Airways 2014a).

Jetstar also encourage passengers to book directly with the carrier. Interestingly, Jetstar also works closely with travel agents throughout Australia and Asia. Jetstar offer travel agents the following benefits:

- “The ability to earn fixed sector remuneration via Gross Fares
- Access to a secure Travel Site that enables travel agents to easily create new bookings, modify existing bookings, manage their account and agency details
- Keep travel agents up to date with Jetstar news via TradeMail
- Settle via bank settlement plan (BSP) where Jetstar is BSP enabled
- The choice of various payment methods including: Major Credit Card, BSP, UATP
- The ability to book mixed itineraries with third party carries (via code-sharing and Interline agreements)
- The choice to book and make changes via the GDS, Trade Site, API and Call Centre
- Dedicated Sales Support Team including phone and email support
- GSA support in selected markets” (Jetstar Airways 2013d).

3.4.5 Australia’s low cost carrier’s focus on ancillary revenues

As previously mentioned, LCCs maintain low airfares to stimulate new demand from customers who travel by bus or rail or who have never travelled before (Fernie 2011; Flouris & Oswald 2006; Mason 2001).

Therefore, Jetstar offers options for passengers using the concept of the “*customer only pays for what they need*”. Passengers have the option of selecting between two types of fares – Economy or Business (on selected international flights). Once a fare has been selected by the passenger, then the passenger has the option to add on checked baggage and/or a bundle of extras. These extra product offerings include seat selection, in-flight products, fare flexibility, lounge access, as well as Qantas Frequent Flyer points (Qantas Airways 2013).

In 2005, Jetstar introduced a new in-flight entertainment service (the portable digEplayer video-on-demand), on Airbus A320 flights longer than 75 minutes. Passengers were charged \$5 for a journey lasting up to two hours and \$10 for a longer trip for the use of this service (Creedy 2005). In 2010, Jetstar offered iPads as part of their in-flight entertainment to

passengers. Passengers wishing to use this service are charged \$10-\$15 on flights over two hours (Horton 2010; Bachman 2012).

Since May 2011, Jetstar has introduced product bundles. These include flight catering and bar sales, baggage charges, as well as in-flight duty free sales (on international services) (Qantas Airways 2013).

Tiger Airways also earns revenue from a diverse range of sources, including fees for bookings made by the internet and by travel agents, excess baggage charges, sporting baggage charges, booking amendment charges, and preferred selected seat charges (Tiger Airways Holdings 2014b).

3.4.6 The hybridization of Australia's domestic low cost carriers business models: a summary

To sum up, Australian LCCs originally focused on reducing costs in order to maintain a leading price strategy in the markets they serve. The base model of low-cost carriers by which they achieve significantly lower operational costs is based on the following characteristics: the focus on minimizing costs and maximizing efficiency, the use of younger aircraft fleet composed mostly of one aircraft type, the use of secondary and uncongested regional airports, point-to-point network of flights, only one-way fare per flight available at each point in time, direct online ticket sales, one passenger class inside the aircraft cabin, and no in-flight service (Vidovic 2013; Klophaus 2012; Doganis 2009)

However, due to the global economic crisis, higher fuel costs, and increasing market competition, the pure LCCs' business model is proving difficult to sustain. Many LCCs have had to change their business strategies in order to respond to the dynamic changes in air transportation (Vidovic 2013). Consequently, LCCs are increasingly embracing a hybrid business model. The above analysis in this section has shown that Australian LCCs have also been required to adjust their business models in order to counter this market change. Figure 3.2 presents development of key attributes of Australia's domestic LCCs business models. As noted earlier, basically Australian domestic LCCs offer simple products and charge extra fees for additional services and facilities. However, since the market has changed Jetstar has introduced the FFP program for its customers while Tiger offered the "*Infrequent Flyer Club*". This shows that Australia's domestic LCCs products have tended to

move from a simple product to a more complex service offering in response to any changing passenger or market requirements.

Secondly, Tiger Airways has operated with single fleet aircraft. In contrast, Jetstar has introduced a heterogeneous fleet – Airbus A320 and Airbus A321 for Australian domestic services, and Airbus A330 and Boeing B787 aircraft for long-haul services from/to Australia (Thomas 2004). Therefore, only Tiger Airways is still following the fleet structure strategy of the original LCCs' business model (Doganis 2006)

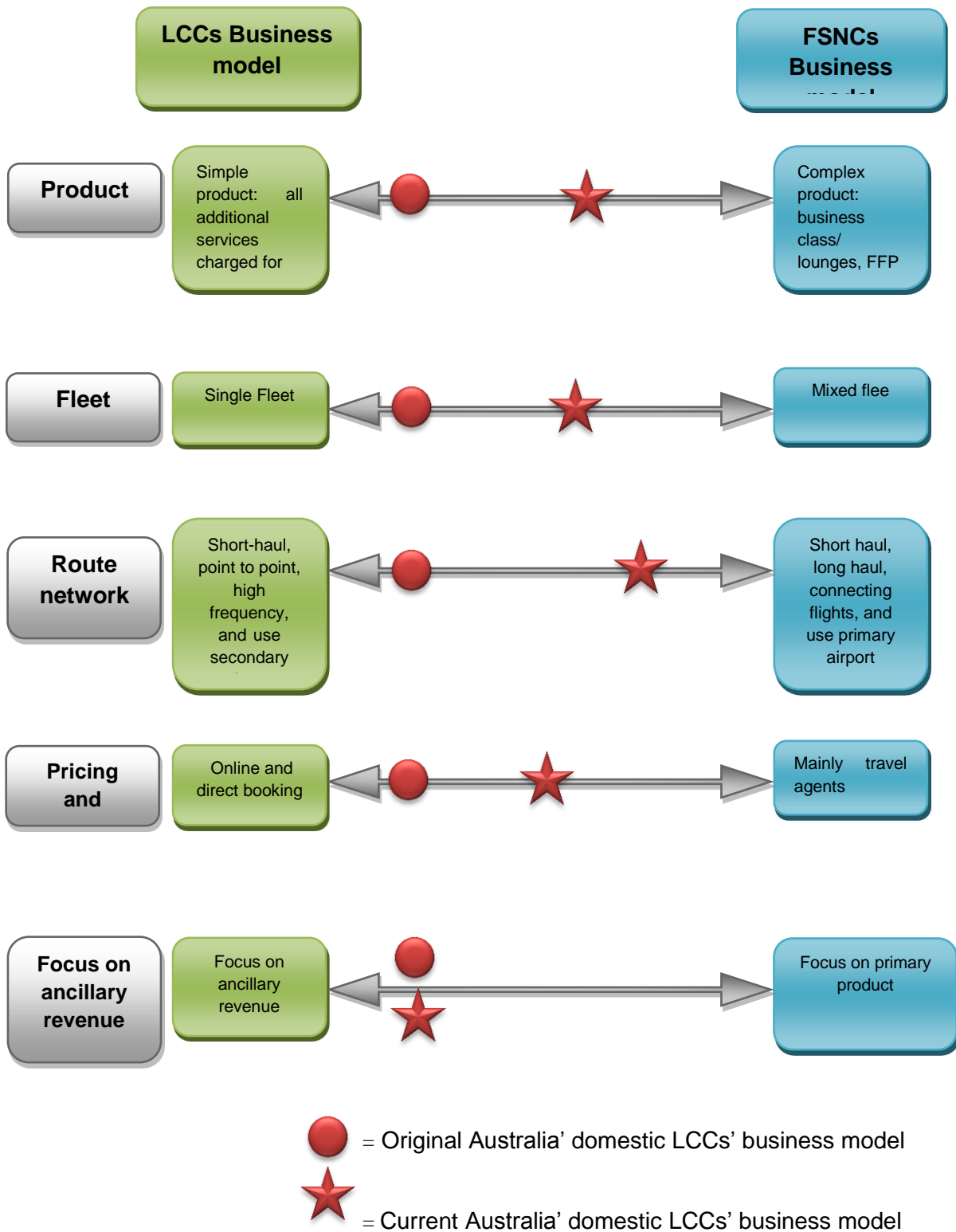


Figure 3.2. Development of key attributes of Australia's domestic LCCs' business models

Third, Australian domestic LCCs generally operate short-haul, point-to-point services, with high flight frequencies, particularly in major markets, such as Melbourne to Sydney. Jetstar uses Avalon Airport (a secondary airport), located nearby to Melbourne in addition to Melbourne Tullamarine Airport – the largest airport in Victoria.

However, Jetstar has gradually expanded its network to long-haul international markets. Jetstar further aims to increase its Asian network, with its so called “Pan Asian Strategy”. As noted earlier, Jetstar has been increasing its participation in strategic alliance, for example, the airline now has code share agreements with Emirates airline (Australian Aviation 2014a). Hence, it can be observed that the Australia’s domestic LCCs route network structure has tended to divert from original LCCs’ business model in response to changing market requirements.

Fourth, Australia’s domestic LCCs basically offer competitive airfares and keep their fare structures simple. Jetstar mainly utilizes online and direct bookings, while Tigerair Australia has introduced bookings via Amadeus travel agencies to strengthen its distribution channel (Tiger Airways 2014a). Therefore, it can be argued that the Australia’s LCCs distribution channel has slightly diverted from the LCCs’ business model.

Finally, as noted in Section 3.4.5 above, Australia’s domestic LCCs have been focusing on ancillary revenues. Examples of these ancillary revenue sources are the charges paid by passengers for in-flight catering and in-flight entertainment services. It can be stated that Australian domestic LCCs still use original LCCs’ business model in terms of focusing on ancillary revenues.

Overall, it can be observed that the Australian domestic LCCs’ business model have developed into a “hybrid” model. This is because they have gradually introduced FSNCs features in response to the dynamic change in airline industry.

3.5 Summary

This chapter has presented an overview of the key characteristics and attributes of the LCCs’ business model. The objective of this discussion was to examine the relevant theories, as they provide an understanding of the LCCs’ business model, and are highly relevant to this study.

The following four chapters propose and empirically test models based on multiple linear regression analysis (MLR), artificial neural network (ANN), genetic algorithm, and adaptive neuro-fuzzy inference system (ANFIS) forecasting approaches. The detailed modelling that is undertaken in these chapters seeks to identify the optimum modelling approach, in terms of accuracy, reliability, and predictive capability, for forecasting Australia's domestic LCC passenger demand – a key aim of this thesis.

CHAPTER FOUR: FORECASTING DEMAND FOR LOW COST CARRIERS IN AUSTRALIA USING A CLASSICAL LINEAR REGRESSION APPROACH

4.1 Introduction

The previous chapters discussed the LCCs' business model and Australia's domestic aviation policy together with its influence on the LCC domestic market segment. The focus of the thesis now turns to detailing modelling of Australia's domestic LCC passenger demand.

This chapter proposes and empirically examines a classical or traditional linear regression approach for forecasting Australia's domestic LCC passenger demand. Whilst it has been noted that recent advances in artificial intelligence-based techniques, such as artificial neural networks (ANNs), genetic algorithm (GA), and adaptive neuro-fuzzy inference system (ANFIS), have been regarded as superior forecasting approaches (see, for example, Alekseev & Seixas 2002, 2009; Tso & Yau 2007; Yetilmezsoy et al. 2011), this study did not wish to ignore the use of a classical linear regression approach, and therefore, proposes and tests two classical multiple linear regression models (one based on Australia's domestic LCCs enplaned passengers (PAX Model) and the second on revenue passenger kilometres performed (RPKs Model) for completeness.

The chapter is organised as follows: in Section 4.2 factors influencing airline passenger demand is discussed; in Section 4.3 the data sources used in the thesis modelling is presented. Section 4.4 examined the specific models formulation and estimation procedures. The results from the models estimated are discussed in Section 4.5.

4.2. Factors influencing Australia's Domestic Low Cost Carrier Passenger Demand

Factors influencing air travel demand are complex (Doganis 2009; Vasigh et al. 2008). Each factor is composed of elements which can either stimulate or reduce air travel demand. For airline passenger demand forecasting purposes, these factors are more conveniently categorised into two broad groups (Ba-Fail et al. 2000). The first group consists of those factors that are external to the airline industry. The second group includes those factors within the industry itself (Ba-Fail et al. 2000). The commencement point for an econometric

analysis is, in effect, a regression equation model postulating a causal relationship between a dependent or explained variable and one or more independent or explanatory variables (Gujarati 2003). The dependent variable in the analysis of airline passenger demand, generally, is the historical airline traffic data measured in terms of enplaned passengers or revenue passenger kilometres performed (RPKs) as these are recognised as the measures of airline demand which has been met (Belobaba 2009; Holloway 2008). The independent variables included in the model are those variables which would have an influence on demand for air travel. The econometric models therefore endeavour to explain demand for air travel as being caused by the changes in the model's independent or explanatory variables (International Civil Aviation Organization 2006).

Leisure travelers, the primary market for LCCs, aim to optimise the utility – or satisfaction – derived from air travel and from associated consumption of vacation experiences, subject to a given income or budget constraint (Brons et al. 2002). Characteristics of leisure travel demand include air travel costs, relative price of other goods, income, together with socio-economic characteristics (Brons et al. 2002).

The primary driver of air travel demand is economic growth (Belobaba & Odoni 2009; Wensveen 2011). The most important socio-economic variable affecting demand for leisure travel¹⁴ is personal or household income. This is because leisure trips are normally paid for by the passenger, who may also be paying for a spouse and one or more children to travel together on a holiday or for some other leisure-related travel purpose (Doganis 2009). Furthermore, higher levels of economic activity will lead to greater demand for air transport services, because of increased business requirements and generally higher spending of consumers. In addition to the strong relationship between the overall level of economic development to air transport activity, the annual rate of growth in air traffic is closely related to the annual rate of world economic growth (Bureau of Transport and Communication Economics 1994, p. 45). Historically, the annual growth in air travel has been around twice the annual growth in gross domestic product (GDP) (Belobaba & Odoni 2009, p. 2).

During periods of economic growth (and when consumer confidence is strong), air travel demand grows. Conversely, when economies fall into recession or experience downturns, unemployment grows, consumer confidence declines, and individuals often postpone discretionary travel and other luxury purchases (Dempsey & Gesell 1997). To illustrate the

¹⁴ The leisure traveller segment consists of several distinct segments: visiting friends and relatives (VFR), vacation travellers, and special event travellers (Shaw 2011).

relationship between airline passenger demand and economic growth, the annual growth rates in world passenger air traffic, as measured by RPKs, are shown in Figure 4.1, for the period 1980-2012. As can be seen in Figure 5.1, the annual growth rates in world RPKs tracked the world real GDP closely, except in 1991 and 2001, which shown the drops in RPKs due to the first Gulf War and the effects of 9/11 terror attacks in the USA.

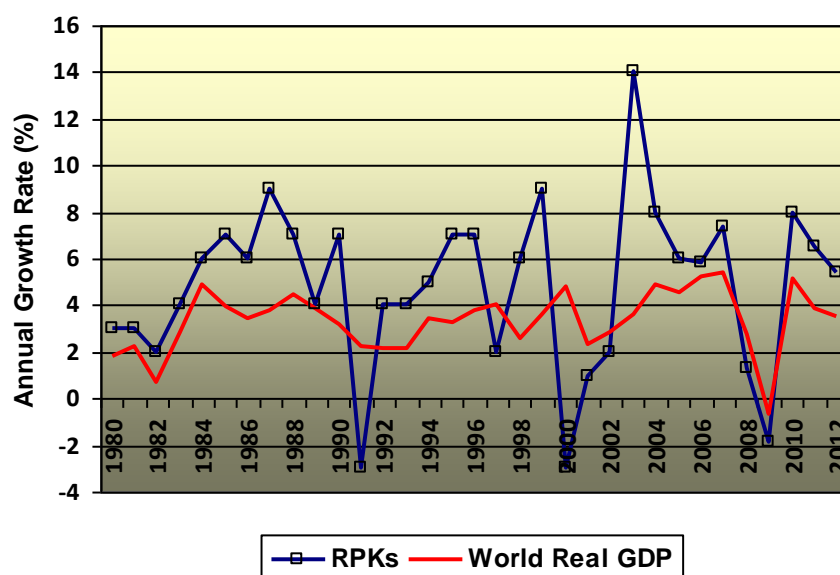


Figure 4.1. The cyclical nature of world airline traffic growth: 1980-2012
 Source: Adapted from Air Transport Association of America (2013); International Civil Aviation Organization (2008-2013), International Monetary Fund (2014).

Real GDP and real GDP per capita were used to measure the effect of income on Australia's domestic LCC passenger demand (Doganis 2009; International Air Transport Association 2008).

One of the key factors influencing a consumer's decision to travel by air is the price of air travel. Individuals travelling for leisure purposes normally tend to be more sensitive to price and income than those travelling for business purposes. As a general rule, leisure travelers typically tend to book their travel well in advance, are prepared to travel at less popular times and are less likely to change their travel plans (Bureau of Transport and Communication Economics 1994). A decrease in the real cost of air travel positively influences air traffic growth (Hanlon 2007; Holloway 2008). However, measurement of the price of air travel is normally complicated by the presence of different fare classes offered by airlines (International Civil Aviation Organization 2006). Hence, airline passenger yields are often used as a proxy for air fares, which can be difficult to obtain given the wide use of a variety of, and fluctuating number of, discount fares. In the absence of changes in other factors

influencing air travel demand falling yields, tend to increase traffic. Conversely, rising yields tend to reduce traffic volumes, subject to demand elasticities (Doganis 2009).

In addition, as many LCCs have developed into sizeable operations, there is evidence suggesting that leisure travellers are taking more frequent, shorter-duration vacations (Graham 2006). However, the increase in multiple holidays is limited by the amount of annual vacation days people can take (Mason 2007). Leisure travel also competes with other ways people may spend their disposable income. In recent years home computers, high definition televisions and ipods have also increased in popularity and vie for leisure travellers' disposable consumption (Graham 2000). Hence, even though the number of perfect substitutes for air travel may not be overwhelming, leisure travel, compared to business travel, has some additional substitutes inside as well as external of the transport sector and therefore tends to be more sensitive to changes in air fares, implying higher absolute price elasticity (Brons et al. 2002).

The impact of Australia's demographic changes was considered through the annual population (Tsekeris 2009; Young & Wells 2011) and unemployment rates. Population has a direct effect on the size of an air travel market and may cause a bias in the estimates if omitted. For instance, a large increase in air traffic may reflect a sudden increase in population rather than other effects (International Air Transport Association 2008). In addition, employment also influences air travel demand (Doganis 2009). *Ceterus paribus*, rising levels of employment tend to positively influence air travel demand, while increasing levels of unemployment tend to dampen or depress air travel demand (McKnight 2010). This occurs because there are significant economic effects associated with employment. The standard of living of certain demographic groups and individuals will be affected by changes in the incidence of a country's employment and unemployment rate (Martin 1991). Job losses result in significant declines in income and hence consumption for individuals and their families. Job losses also have a "snow-ball" effect as the reduction in expenditure by families experiencing loss of jobs means further loss of demand for businesses, resulting in further unemployment (Goolsbee 2010).

Air transport and tourism¹⁵ are inter-related. Consequently, there is a strong association between levels of air travel demand and tourism demand. Air transport can influence tourism demand via a number of channels, with price being one of the key factors (Koo et al. 2013). Thus growing demand for air travel, associated with the rapid growth of LCCs, has assisted

¹⁵ In this thesis, a *tourist* is defined as a temporary visitor staying at least 24 hours in a region for the purpose of leisure (holidays, recreation, sport), business, family (visiting friends or relatives), or attending conferences or meetings (Reisinger 2009, p. xviii).

tourism growth (Davidson & Ryley 2010). The majority of the demand for LCCs services is from leisure travellers (Graham 2006), although Mason (2005) has observed that there is an increasing number of business travellers who view LCCs flights as providing good value, flexible ticket options, particularly on specific routes where frequency is tailored to satisfy business demand. LCCs are significant influences in development of weekend, city or short-break tourism and are influencing expansion of potential destinations (Graham & Shaw 2008). Visiting friends and relatives (VFR) traffic have also fed the LCCs (Bieger & Wittmer 2006). LCCs are also extending the range of motivations and frequency of travel for private leisure reasons through their highly efficient websites, where customers can purchase not only an air ticket, but also reserve a hotel, rent a car, and purchase travel insurance (Olipra 2012).

The tourism industry makes a substantial and important contribution to the overall level of economic activity and employment in Australia. As is the case with most developed economies, Australia's tourism industry is heavily oriented towards domestic expenditure by Australian residents (Hooper & van Zyl 2011). Domestic tourism accounts for three-quarters of tourism expenditure in Australia, with the balance accounted for by international tourists spending (Hooper & van Zyl 2011; OECD 2014). The Australian Bureau of Statistics (ABS) collects a range of Australian tourism-related statistics. Unfortunately, the number of tourists carried by Australia's domestic LCCs are not recorded, nor reported. The Bureau of Infrastructure, Transport, and Regional Economics (BITRE), another Australian Government tasked with collecting transport mode data, also do not publish data on the number of tourists carried by Australia's domestic LCCs. A further search for this data was made by examining the statistics published by Tourism Australia and Tourism Research Australia, the two Australian Government peak tourism organisations. Once again, neither of these agencies provided the number of tourists carried by Australia's domestic LCCs.

Therefore, in the absence of the actual data relating to the number of tourists (both domestic and international origin) carried by Australia's domestic LCCs, careful attention was paid to identifying a suitable proxy variable that could be included in the models to examine the influence that tourism may have on Australia's domestic LCC passenger demand. This study therefore followed the approach of Tsekeris (2009), which has been cited in at least fourteen other studies, who has argued that tourism attractiveness, which is expressed in terms of the tourist accommodation infrastructure, that is, the reported bed capacity, can be included as a variable in air travel demand modelling (Tsekeris 2009).

Short-term conditions such as official interest rates can also have a strong influence on the growth potential of both individual airlines and the total industry (Abed et al. 2001). Interest rates influence the balance between expenditure and saving (Cook 2007). So if interest rates drop, this may influence demand for goods and services. This is because many homeowners have a mortgage and a falling interest rate will increase their discretionary income. This is the income they have available to purchase non-necessities. Hence, they will purchase more of most normal goods and services (Wilkinson 2005). Furthermore, high interest rates will also inhibit economic activity, which can have a dampening effect on airline traffic (Wensveen 2011).

Jet fuel prices are another influential factor for air travel demand (Gesell 1993). Sharp increases in world oil prices have important (though temporary) impacts on world air travel demand. In addition to the adverse impact on the global economy, airlines are often forced to increase air fares to cover higher fuel costs, which often have a detrimental impact on air travel demand (Li 2010).

4.3 Data Sources

The availability of a consistent data set allows use of quarterly data for the period 2002 to 2014. The data used in the models developed and empirically examined in this thesis were sourced from a variety of sources. Data on Australia's real GDP and real GDP per capita, Australia's unemployment numbers, population size and recorded bed capacities at Australia's tourist accommodation establishments¹⁶ are from the Australia Bureau of Statistics (ABS). Australia's real interest rates are from the Reserve Bank of Australia (RBA). The airfare data are from the Bureau of Infrastructure, Transport and Regional Economics (BITRE) (airline yields are used as a proxy of average airline fares and are based on Australia's real best discount air fares). The data on Australia's domestic LCCs enplaned passengers and revenue passenger kilometres performed (RPKs) are from the Bureau of Infrastructure, Transport and Regional Economics (BITRE), Qantas Group, Tiger Airways and Virgin Australia reports and websites. World jet fuel prices (expressed in Australian dollars) were sourced from the US Energy Information Administration (EIA). To change data from current prices to real or constant prices, this study used the consumer price index (CPI) at 2011 constant prices (Ba-Fail et al. 2000).

Table 4.1 presents a summary of the dependent and independent variables included in the study, their unit of measurement, and their data source.

¹⁶ Based on Australian tourist accommodation establishments with 15 rooms or more.

Table 4.1. Summary of the study dependent and independent variables, units of measurement, and data sources¹⁷

Variables	Data measurement	Source
Australia's LCCs enplaned passengers	Thousands	BITRE, QF,VA,TT
Australia's LCCs revenue passenger kilometres	Millions	BITRE, QF,VA,TT
Australia's real air fare levels (Yield)	Index	BITRE
Australia's population size	Thousands	ABS
Australia's real GDP	AUD\$ Millions	ABS
Australia's real GDP per capita	AUD\$	ABS
Australia's unemployment size	Thousands	ABS
World jet fuel price	AUD\$ per gallon	EIA
Australia's real interest rates	Per cent	RBA
Australia's tourism accommodation bed capacity	Number of bed spaces	ABS

Legend: QF = Qantas Group; VA = Virgin Australia; TT = Tiger Airways

4.4 Model Specifications and Estimation Procedures

Most econometric forecasts¹⁸ of air traffic tend to be based on multiple regression models, where traffic is a function of one or more independent variables. The two variables most frequently used are the air fare and some measure of per capita income (Doganis 2009). The standard approach used in air transport modelling and forecasting is to define it as a procedure in which two vectors from different domains (a vector constructed from socio-economic factors and a further vector constructed from air transport system factors) can be combined through mapping, so that the target demand forecasting can be accomplished (Alekseev & Seixas 2009; Rengaraju & Arasan 1992).

Multiple linear regression (MLR) is a linear statistical technique which is very useful for predicting the best relationship between an explained variable or dependent variable and several explanatory variables or independent variables (Tiryaki & Aydin 2014). MLR is based on least squares: the model is fit such that the sum of squares of variances of actual and forecast values is minimized (Tiryaki & Aydin 2014).

A general MLR model can be formulated as per the following equation:

$$Y = \beta_0 + \beta_1 X_1 + \beta_2 X_2 \dots + \beta_i X_i + \varepsilon \quad (4.1)$$

¹⁷ Data of all variables are plotted and presented in Appendix 6.

¹⁸ According to Stock and Watson (2003, p.527), 'Forecasting pertains to out of sample observations whereas prediction pertains to in sample observations'.

where Y is the explained variable, X_i represents explanatory variables, β_i represents forecast coefficients, and ε is the error term (Tiryaki & Aydın 2014).

The most critical step in attempting to examine the relationship between variables is to form the relationship in a mathematical function, that is, to specify the model(s) with which the economic phenomenon may be explored empirically (Ba-Fail et al. 2000). In the remainder of this chapter, two econometric models are specified and tested based on Australia's quarterly LCCs enplaned passengers (PAX Model) and revenue passenger kilometres (RPKs Model).

The first step of this study was to define the independent variables of the MLR models for forecasting Australia's domestic LCC passenger demand models. After reviewing and collecting data related to the characteristics of the relationships between causative factors and air travel demand as well as reviewing the extant literature on factors influencing air travel demand, the following list of economic and socio-demographic factors were selected for inclusion in the study's modelling:

- Australia's real gross domestic product (GDP),
- Australia's real gross domestic product per capita (GDP per capita),
- Australia's population size
- Australia's unemployment size
- Australia's real interest rates
- Australia's tourism accommodation bed capacity
- World jet fuel prices
- Australia's real air fare levels (Yield)

Three dummy variables were included in the models. The first dummy variable explained the impact of the evolving Virgin Australia business model from a LCCs model to a FSNC (Whyte et al. 2012) on Australia's LCC traffic (enplaned passengers and RPKs). Australia's domestic LCCs' traffic has decreased significantly since 2011 primarily due to this transition

in Virgin Australia's business model. Thus, the dummy variable reflecting the Virgin Australia changing business model (DUMMY 1) is zero for the period from Quarter 1 2002 to Quarter 4 2010 and one for otherwise.

The second dummy variable (DUMMY 2) accounted for the loss of capacity following the collapse of Ansett Australia in 2001¹⁹. At the time of its collapse in 2001, Ansett Australia's domestic Australian market share was 35 per cent (Virgin Blue held around 10 per cent and Qantas had a 55 per cent market share) (Prideaux 2003). The collapse of Ansett Australia had a major impact on the tourism industry, especially in regional areas where Ansett's subsidiaries provided substantial capacity. Whilst other incumbent airlines increased seating capacity, the demand for seats exceeded supply for several months (Prideaux 2003). The dummy variable accounted for the loss of capacity following the collapse of Ansett Australia (DUMMY 2) is one for the period from Quarter 1 2002 to Quarter 2 2002 and zero for otherwise.

The third dummy variable accounted for the impact of the Commonwealth Games held in Melbourne from 15 to 26 March, 2006. The 2006 Melbourne Commonwealth Games was the largest sporting and community event held in Victoria's history. The Commonwealth Games provided substantial economic benefits for the State of Victoria, and for the travel industry as well, as the total expenditure associated with the Commonwealth Games was around \$AUD 2.9 billion. The Commonwealth Games also generated 166,513 visitors. These visitors comprised 57,010 overseas visitors, 60,125 interstate visitors, 37,035 regional Victoria visitors and 12,343 other visitors (KPMG 2006). Thus, the dummy variable accounted for the impact of the Commonwealth Games (DUMMY 3) is one for Quarter 1 2006 and zero for otherwise.

The ICAO (2006) suggests that dummy variables can be included in econometric models to account for such trends.

Figure 4.2 presents a schematic description of the steps taken in the econometric analysis of the factors affecting Australia's domestic LCC passenger demand, as measured by enplaned passengers and revenue passenger kilometres performed (RPKs).

¹⁹ Ansett Australia experienced financial problems and was placed into receivership on September 14, 2001 (Easdown & Wilms 2002).

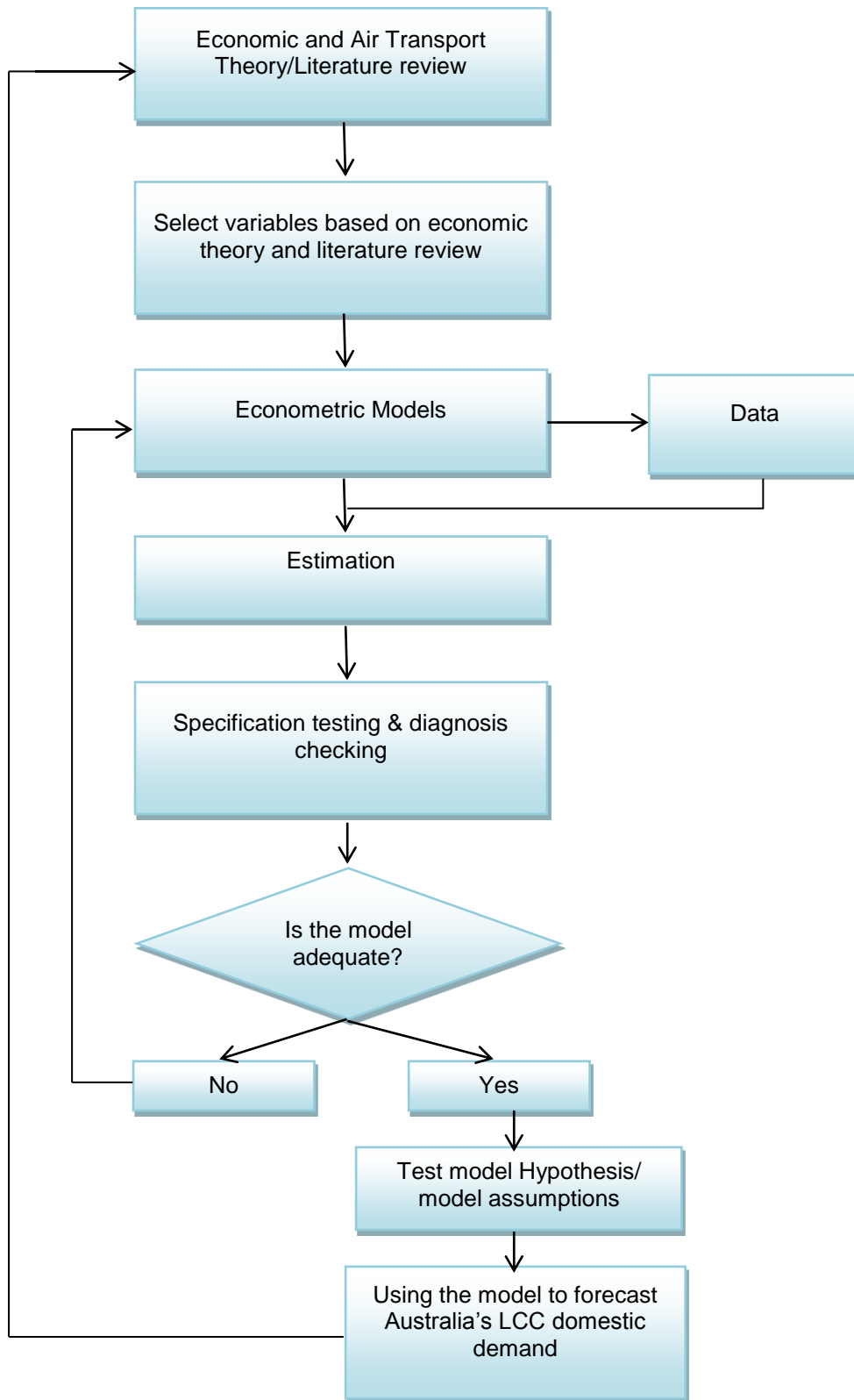


Figure 4.2. Schematic description of the steps taken in the econometric analysis of Australia's domestic LCC passenger demand
Source: based on Maddala (2001).

Table 4.2A presents the correlation matrix, from which the variables were analysed for inclusion in the model development.

Table4.2A. Correlation matrix for all independent variables

	FARE	POP	GDP	GDPPC	UEMP	ACCOM	FUEL	INT
FARE	1.00							
POP	-0.88	1.00						
GDP	-0.76	0.93	1.00					
GDPPC	-0.55	0.74	0.94	1.00				
UEMP	-0.18	0.20	0.03	-0.15	1.00			
ACCOM	-0.84	0.92	0.90	0.76	-0.05	1.00		
FUEL	-0.65	0.78	0.79	0.70	-0.31	0.82	1.00	
INT	0.31	-0.27	-0.12	0.05	-0.69	-0.14	-0.00	1.00

The correlation matrix shows high correlation between population and GDP at 0.93 and between GDP and GDP per capita at 0.94 respectively which indicates the covariance amongst the variables ²⁰(Ba-Fail et al. 2000). Since GDP per capita is the GDP divided by total population number, this study therefore used Australia’s real GDP per capita²¹ as an income measure in the PAX and RPKs multiple linear regression models (Ba-Fail et al. 2000). It can be seen from table 4.2B that using the GDP per capita instead of GDP and population, the correlation value amongst selected independent variables is lower than 0.9 which indicates that there is no covariance amongst selected variables”

Table4.2.B. Correlation matrix of selected independent variables

	FARE	GDPPC	UEMP	ACCOM	FUEL	INT
FARE	1.00					
GDPPC	-0.55	1.00				
UEMP	-0.18	-0.15	1.00			
ACCOM	-0.84	0.76	-0.05	1.00		
FUEL	-0.65	0.70	-0.31	0.82	1.00	
INT	0.31	0.05	-0.69	-0.14	-0.00	1.00

Therefore, the demand model for Australia’s domestic LCCs air travel may comprise the following list of economic and socio-demographic factors:

- Australia’s real gross domestic product per capita (GDP per capita),

²⁰ It is suggested that the correlation value greater than 0.9 indicates an existing of covariance amongst variables (Ba-Fail et al. 2000).

²¹ Australia’s real GDP per capita is an inflation-adjusted by using consumer price index (CPI) of 2011 as a base year.

- Australia's unemployment size
- Australia's real interest rates
- Australia's tourism accommodation bed capacity
- World jet fuel prices
- Australia's real air fare levels (Yield)

Three dummy variables were also tested in the modelling. The first dummy variable (DUMMY 1) reflected the Virgin Australia changing business model from an LCC model to a FSNC. The second dummy variable (DUMMY 2) accounted for the loss of capacity following the collapse of Ansett Australia (Prideaux 2003). The third dummy variable (DUMMY 3) accounted for the impact of the Commonwealth Games held in Melbourne from in March, 2006.

4.5 Classical Linear Regression Modelling Results

Multiple regression analysis was performed using the SPSS software (Statistical Package for the Social Science) Version 22 and Eviews Version 7.2.

The two multiple linear regression models, PAX and RPKs, offering the best fit in terms of goodness-of-fit measures and model accuracy for Australia's domestic LCC passenger demand are:

$$(1): PAX = -22977.26 - 16.49X_1 + 1.94X_2 - 212.58X_3 + 620.68X_4 - 4758.36X_5$$

(Adj. $R^2 = 0.955$, S.E. = 339.00), and

$$(2): RPKs = -29708.15 - 18.79X_1 + 2.39X_2 - 198.26X_3 + 632.05X_4 - 4981.65X_5$$

(Adj. $R^2 = 0.960$, S.E. = 384.97).

Here PAX is Australia's domestic LCC enplaned passengers, RPKs is Australia's domestic LCC revenue passenger kilometres performed, X_1 is airfare (Australia's real best discount air fare), X_2 is Australia's real GDP per capita, X_3 is Australia's real interest rates, X_4 is World jet fuel price, and X_5 is dummy variable (DUMMY 1) reflecting Virgin Australia's changing business model.

The modelling results are summarised in Table 4.3 and shows the high R^2 for both models. The high R^2 values indicate the variations between the variables are explained well by the models both of which have very small standard errors. The high “ t ” values for the coefficients indicate these variables are stable. Attempts to use additional variables failed to improve the models fit, (Alekseev & Seixas 2009).

It was found that Australia’s real GDP and population were not used as independent variables in the same model, due to the statistical insignificance. As we have noted above, the study used two income measures in the modelling: Australia’s real GDP and real GDP per capita (GDP per capita is the gross domestic product divided by size of the population). Due to their direct relationship, gross domestic product (GDP) and GDP per capita were not used as explanatory variables in the same model (Ba-Fail et al. 2000).

Also, the endogeneity issue which is likely to be appeared in econometric model when a choice variable placed on the right-hand side of an equation is indirectly affected by the left-hand side’s variable and will lead to biased and inconsistent estimation in econometric model was taken into account (Chenhall & Moers, 2007). In this study, the Australia’ tourism accommodation bed capacity which used as a proxy of tourism variable might cause an endogeneity issue since it is a function of tourism demand. However, the result was found that bed capacity was not included into the MLR models, both PAX and RPKs models, due to its statistically insignificance. Therefore the endogeneity is not an issue of this study.

Table4.3.The predictors of Australia’s domestic LCC passenger demand

Independent Variables	PAX	RPKs
X ₁ Air fare	-16.49	-18.79
<i>SE</i> ²²	(7.26)	(8.20)
<i>t</i>	(-2.27)	(-2.29)
<i>P - value</i>	(0.03)	(0.03)
<i>VIF</i>	(6.15)	(6.20)
X ₂ GDP per capita	1.94	2.39
<i>SE</i>	(0.19)	(0.18)
<i>t</i>	(10.17)	(13.09)

²² This study used HAC (heteroscedasticity and autocorrelation consistent) procedure to correct the bias of standard errors and t-statistics, if present (Gujarati 2003). (See Appendix 4)

<i>P - value</i>	(0.000)	(0.000)
<i>VIF</i>	(8.91)	(9.41)
X ₃ interest rates	-212.58	-198.26
<i>SE</i>	(76.85)	(81.27)
<i>t</i>	(-2.77)	(-2.44)
<i>P - value</i>	(0.009)	(0.02)
<i>VIF</i>	(3.24)	(3.18)
X ₄ Fuel	620.68	632.05
<i>SE</i>	(197.78)	(202.31)
<i>t</i>	(3.14)	(3.12)
<i>P - value</i>	(0.004)	(0.010)
<i>VIF</i>	(13.16)	(12.52)
X ₅ Dummy 1	-4758.36	-4981.65
<i>SE</i>	(160.01)	(175.70)
<i>t</i>	(-29.74)	(-28.35)
<i>P - value</i>	(0.000)	(0.000)
<i>VIF</i>	(2.71)	(2.60)
Constant	-22977.26	-29708.15
<i>SE</i>	(2986.38)	(2832.19)
<i>t</i>	(-7.69)	(-10.49)
<i>P - value</i>	(0.000)	(0.000)
<i>R-squared</i>	0.961	0.960
<i>Adj. R-squared</i>	0.955	0.953
<i>F</i>	152.64	147.718
<i>P-value (F-statistic)</i>	0.000	0.000
<i>Durbin Watson (DW)</i>	1.86	1.81

Hypotheses Testing: Each regression coefficient to be tested for significance, the null hypothesis is that the true population value of each regression coefficient individually is zero (Gujarati 2006). The two tailed t statistics²³ is therefore applied to test this hypothesis and displayed in Table 4.3. If the absolute value of the t value is greater than the critical t value the null hypothesis will be reject and can be concluded that the population value of the coefficient is probably not zero. From the results in table 4.3, since the absolute value of t value of the intercept coefficient is larger than the critical t value, and the absolute value of t value of the slope coefficient is also larger than the critical t value, the null hypothesis in both cases were rejected and can be concluded that both the intercept and slope coefficients are significantly different from zero.

The R-squared Coefficient (R^2): The coefficient of determination²⁴, R^2 and adjusted R^2 , of PAX and RPKs models are 0.961, 0.955 and 0.960 and 0.953, respectively. These values indicate a good fit of model that over 90 per cent of variance in the dependent variable was explained by independent variables (Ba-Fail et al. 2000). When adjusted for degrees of freedom the model maintained good explanatory power for both the PAX and RPKs models at 95.5 per cent and 95.3 per cent respectively.

The F-test for Overall Significance: The F -test helps evaluate a regression's overall significance. While the t -test can be used only on the null hypothesis involving one slope coefficient, the F -test can test hypotheses with more than one slope coefficient. The null hypothesis is that all slope coefficients in a regression are zero. The alternative hypothesis is that at least one of all slope coefficients in a regression is not zero. Hence, where the F -statistic is greater than its critical value, the null hypothesis will be rejected. If this is not the case, this means none of the independent variables explain the dependent variable (Ba-Fail et al. 2000). Table 4.3 shows F values are high for both the PAX and RPKs models and the observed significance level is less than 0.0005. The findings therefore indicate there is a significant relationship between the dependent variable and the independent variables.

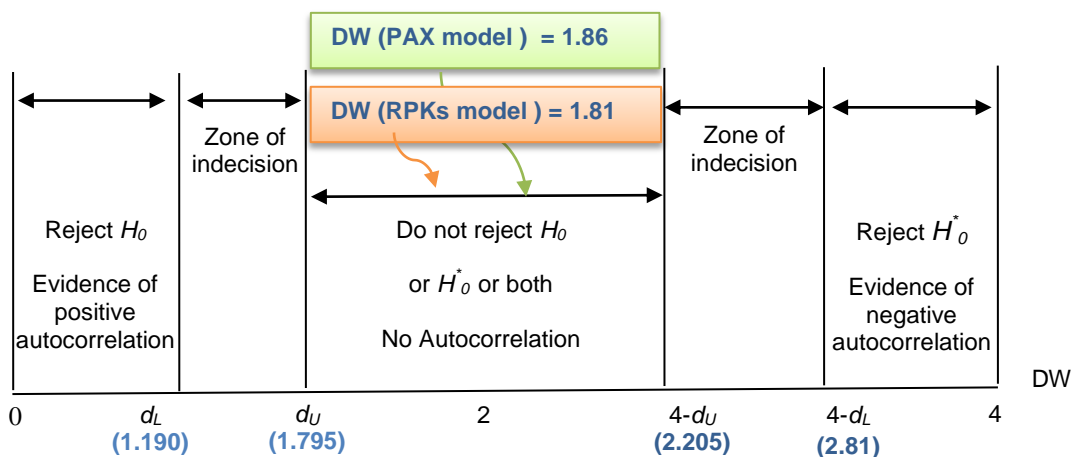
²³The two-tailed t -test is used to test whether such a null hypothesis stands up against the (two-sided) alternative hypothesis that true population coefficient is different from zero, If α is set at 0.05 or 5 per cent level, the two-tailed critical t value is about 2.021 for 34 degrees of freedom (d.f.) (Ba-fail et al. 2000, p.81).

²⁴ The coefficient of determination, R^2 , explains the proportion of variance in the dependent variable that can be explained by the independent variables (Ba-Fail et al. 2000 p.82).

Measures of Autocorrelation²⁵: The Durbin Watson (*DW*) statistic is used to measure autocorrelation (Lee et al. 2013), that is, to detect whether there is any correlation between members of observations ordered in time. If the computed *d* value is closer to 0, there is evidence of positive autocorrelation, but if it is closer to 4, there is evidence of negative autocorrelation. The closer the *d* value is to 2, the more the evidence is in favour of no autocorrelation (Ba-Fail et al. 2000). This is only an initial detection, however to precisely determine if autocorrelation is present in the model, the Durbin Watson statistic test is needed. The actual procedure of the Durbin Watson test is illustrated in Figure 4.3.

Table 4.3 shows that the computed Durbin Watson statistic values for Australia’s domestic LCC PAX and RPKs air travel demand models are 1.86 and 1.81, respectively. The computed Durbin Watson statistic values were then compared to the Durbin Watson critical value which can be obtain from the Durbin Watson statistical table. From the Durbin Watson statistical table (Gujarati 2003, p.970) where *n* (number of observations) =37, *k* (number of independent variable) = 5 and level of significance = 0.05, the lower limit of Durbin Watson statistic (*d_L*) is 1.190, and the upper limit of Durbin Watson statistic (*d_U*) is 1.795. These Durbin Watson statistics were plotted in the Figure 4.3.

It can be seen that the Durbin Watson test of the PAX model (1.86) and the RPKs model (1.81) fell in the range of $d_U < DW < 4-d_U$ which can be concluded that there is no statistically significant autocorrelation.



H_0 : No positive autocorrelation

H_0^* : No negative autocorrelation

²⁵ The possibility of autocorrelation and multicollin ster when using regression models. The autocorrelation problem occurs when the error terms produced by the regression equation fall into a pattern. The multicollinearity problem occurs if the independent variables are not statistically independent of each other. For example, GDP and population may move more or less in unison. Therefore, including both as independent variables would result in multicollinearity and would pose difficulties in interpreting the regression coefficients (Doganis 2009).

Figure 4.3. Durbin – Watson statistics
Source: Gujarati (2003, p. 469)

Measure of Collinearity¹⁵: One assumption of the multiple linear regression (MLR) model is that there is no exact linear relationship or multi-collinearity among explanatory variables. Collinearity refers to the situation in which there is a high multiple correlation when one of the independent variables is regressed on the others, that is, there is a high correlation between independent variables (Ba-Fail et al. 2000). The variance inflation factor (*VIF*) was used as an indicator of multi-collinearity. The larger the value of *VIF*, the more collinear the variable would be considered (Gujarati 2006). Although there is no theoretical basis for how the size of *VIF* is related to the degree of multi-collinearity, the normal practice being that if the *VIF* of a variable exceeds 10, that variable would be considered to be highly collinear (Gujarati 2003). The output in Table 4.3 shows that the *VIF* value of all variables are less than 10, except the *VIF* value of the world jet fuel price (13.16 for PAX model and 12.52 for RPKS model). However, according to Shmueli (2010, p.12) “Multicollinearity is not a problem unless either the individual regression coefficients are of interest, or attempts are made to isolate the contribution of one explanatory variable to Y, without the influence of the other explanatory variables. Multicollinearity will not affect the ability of the model to predict.”

Measures of Heteroscedasticity: Both the graphic test and White’s General Heteroscedasticity Tests²⁶, were used to detect the presence of heteroscedasticity. The model’s residuals were examined to see (Figure 4.4) if they were affected by any of the independent variables by performing a regression of the residual from the original regression and independent variables.

In Figure 4.4, the PAX and RPKs models residuals are plotted against the forecast PAX and RPKs (fitted) regression lines, respectively. The objective being to visually determine, whether the forecast mean values of the PAX and RPKs are systematically related to the residuals. Figure 4.4 shows that there is no systematic pattern between the variables, suggesting that no heteroscedasticity is present in the data (Gujarati 2003).

PAX model

RPKs model

²⁶ A general test to detect heteroscedasticity, was introduced by White (1980), and is performed using an auxiliary regression of the squared residuals on all the squares and cross products of the explanatory variables (Alexander 2008, p. 177).

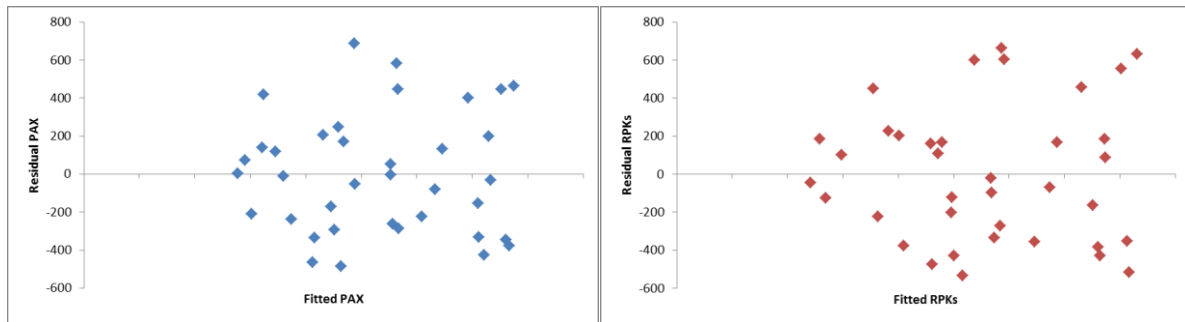


Figure 4.4. Plots of the Australia's domestic LCC PAX and RPKs multiple linear regression models residuals and fitted values.

To further test for heteroscedasticity in the models, a *White* test was performed. The *White* test statistic is given by the sample size (n) times the R -square obtained from the auxiliary regression which asymptotically follows the chi-square distribution (Gujarati 2003). If the obtained chi-square value exceeded the critical chi-square value at the selected level of significance, the conclusion would be that there was heteroscedasticity (Seddighi 2011). The White general heteroscedasticity tests results for Australia's domestic LCC PAX and RPKs air travel demand models are shown in Table 4.4.

Table 4.4. Whites General Heteroscedasticity Test results for Australia's domestic LCC PAX and RPKs passenger demand models

PAX model	n*R-squared	6.89	Probability	0.2451
RPKs model	n*R-squared	7.33	Probability	0.2090

Since the White general heteroscedasticity test statistic of Australia's domestic LCC PAX model and RPKs model are 6.89 and 7.33, respectively, which has, asymptotically, a chi-square distribution of 5 df. The 5 per cent critical chi-square value for 5 df is 11.07. Thus, a heteroscedasticity problem was not detected in the Australia's domestic LCC PAX and RPKs models on the basis of the White test (Gujarati 2003).

The assumption of normality of errors: The multiple linear regression model requires an assumption that residuals of model are normally distributed (Rachev et al. 2010). To detect this, residuals and frequency is plotted as shown in Figure 4.5. It can be observed from Figure 4.5 that both the PAX and RPKs models have a bell shape pattern. This indicates both the Australia's domestic LCC PAX and RPKs models residuals are distributed approximately normally (Gujarati 2006). Accordingly, it can be concluded that both

Australia's domestic LCC PAX and RPKs models satisfied the assumption that the residuals were normal.

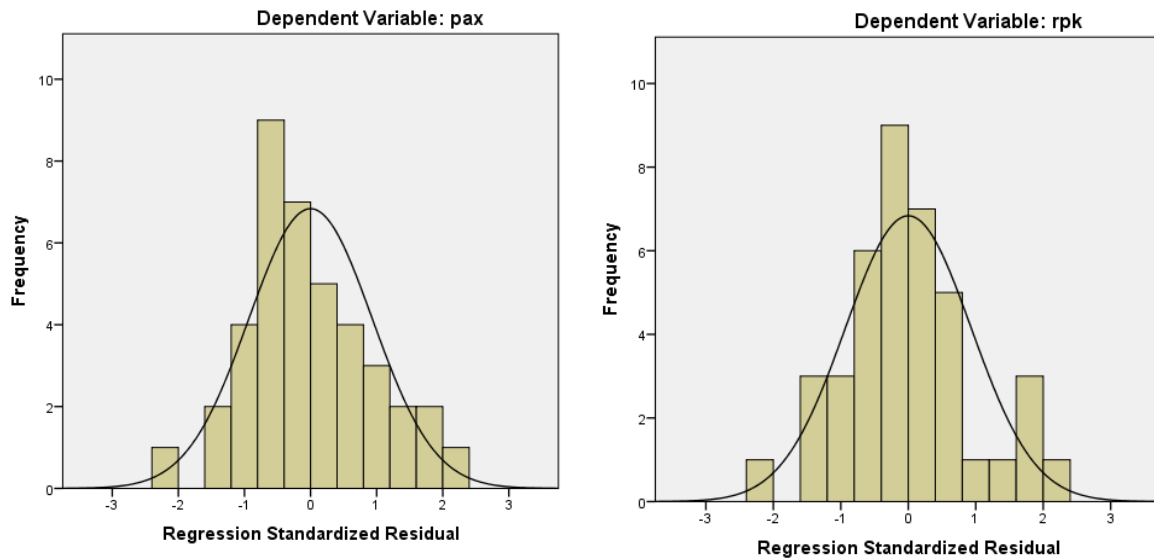


Figure 4.5. Distribution of the residuals for Australia's domestic LCC PAX and RPKs models

To further verify the accuracy and reliability of the models, four goodness-of-fit measures were calculated for both the PAX and RPKs models: mean absolute error (MAE), mean absolute percentage error (MAPE), means square error (MSE), and root mean square error (RMSE) Equations (5.2) to (5.5) (Kunt et al. 2011).

$$MAE = \frac{1}{N} \sum_{i=1}^N [|t_i - td_i|] \quad (5.2)$$

$$MAPE = \frac{1}{N} \left(\sum_{i=1}^N \left[\left| \frac{t_i - td_i}{t_i} \right| \right] \right) \times 100 \quad (5.3)$$

$$MSE = \frac{1}{N} \sum_{i=1}^N (t_i - td_i)^2 \quad (5.4)$$

$$RMSE = \sqrt{\frac{1}{N} \sum_{i=1}^N (t_i - td_i)^2} \quad (5.5)$$

Where t_i is the actual values, td_i is the predicted values, N is the total number of data points, and \bar{td} is the average of the predicted values (Tiryaki and Aydın, 2014, p. 104).

In this study, the first group of 37 data was used as the estimating set (about 75 per cent of the data), and the remaining 12 out of sample data (about 25 per cent of the data) which had not been previously used in the models estimation, was used for verifying and testing the robustness of the models. The performance index of the estimating data set, testing and overall data set of Australia's domestic LCC PAX and RPKs models, as measured by MAE, MAPE, MSE and RMSE values, are presented in Table 4.5²⁷.

Both PAX and RPKs models show MAPE value in out of sample testing data set of 8.63 and 11.11 per cent, respectively. Martin & Witt (1989) in their study which focussed on the accuracy of econometric forecasts of tourism (a paper which has also been cited in at least 84 other reported studies), stated that the forecasting performance of a model is considered to be 'highly accurate forecasting' when the mean absolute percentage error (MAPE) is smaller than 10 per cent ($MAPE < 10\%$). According to the two authors, forecasting accuracy can be considered as "good forecasting" if the model's MAPE falls between 10-20 per cent ($10\% \leq MAPE \leq 20\%$), and it can be classified as 'reasonable forecasting' where the MAPE is in the range of 20-50 per cent ($20\% \leq MAPE \leq 50\%$). Furthermore, if the model's MAPE is larger than 50 per cent then Martin and Witt (1989), argued that the model's results must be regarded as 'inaccurate forecasting' (Martin & Witt 1989, p 417). The classification for MAPE is presented in table 4.5

Table4.5.Classification for Mean Absolute Percentage Error (MAPE)

MAPE Value	Forecasting Accuracy
MAPE < 10%	Highly accurate forecasting
$10\% \leq MAPE \leq 20\%$	Good forecasting
$20\% \leq MAPE \leq 50\%$	Reasonable forecasting
MAPE > 50%	Inaccurate forecasting

Source : Adapted from Martin & Witt (1989, p 417).

²⁷ It is observed that the performance index such as MAE, MAPE, MSE and RMSE, show better results for the estimating data than for the testing data set. This is because the testing data set or out of sample data set is the "new data" which has not participated in the building model and it is used to test the "true" performance of forecasting model. While the training data set is used for constructing a forecasting model and it has been seen by the model. Hence, a model's performance on the training data set will generally be better than the model's performance on non-training data set (Michalewicz et al 2006).

Therefore, based on the widely cited Martin and Witt (1989) MAPE values classifications, Australia's domestic LCC PAX model can be considered as "highly accurate forecasting" and RPKs models can be considered as "good forecasting".

Table4.6.Performance index of MLR PAX and RPKs models for estimating, out of sample testing and overall data sets

Performance index	PAX Model			RPKs Model		
	Estimating data	Testing data	Overall data	Estimating data	Testing data	Overall data
MAE	258.58	405.34	294.53	299.48	428.02	330.96
MAPE	5.00%	8.63%	5.89%	5.48%	11.11%	6.86%
MSE	9.6×10^4	3.0×10^5	1.4×10^5	1.2×10^5	2.4×10^5	1.5×10^5
RMSE	310.43	544.28	381.20	352.35	495.31	392.21

The overall forecast and actual values of Australia's domestic LCC enplaned passengers (PAX Model) and RPKs (RPKs Model), during Quarter 1 2002 to Quarter 1 2014, are plotted and presented in Figure 4.6 and Figure 4.7, respectively.

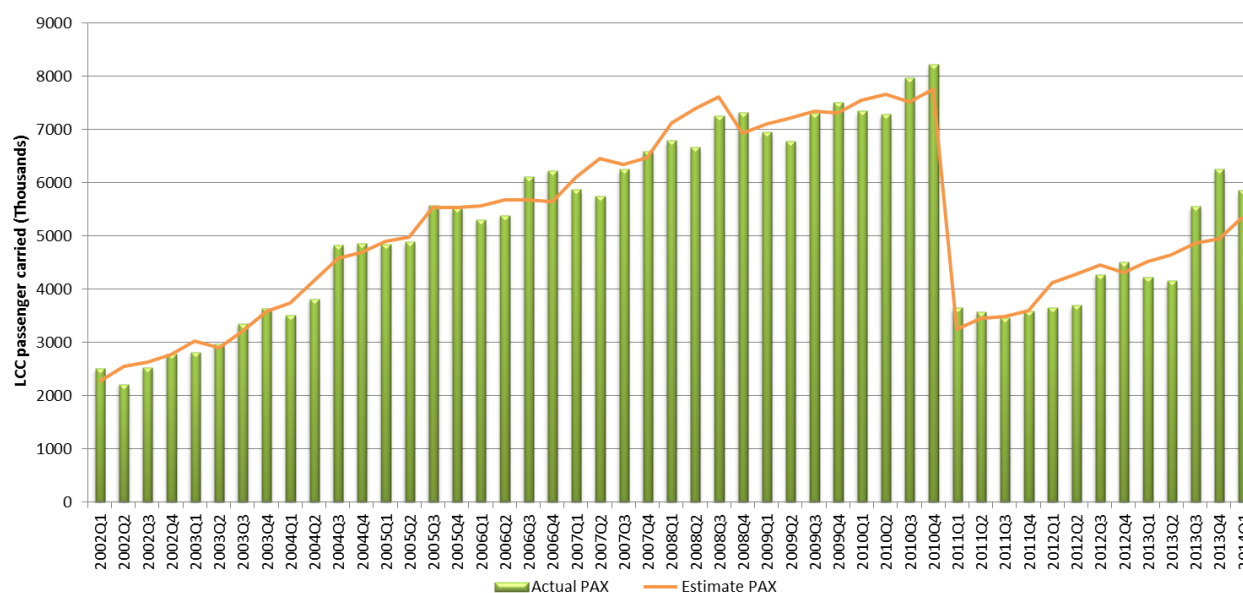


Figure4.6.A comparison of Australia's domestic LCC actual and forecast enplaned passengers (MLR Model)

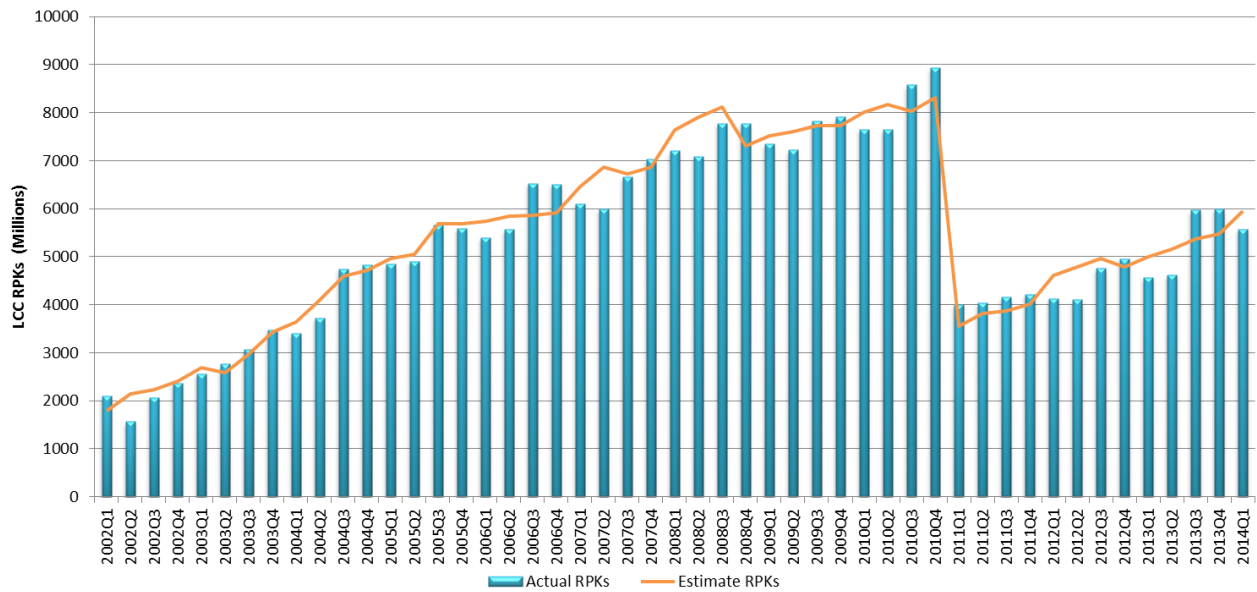


Figure 4.7. A comparison of Australia's domestic LCC actual and forecast RPKs (MLR Model)

4.6 Summary

This chapter has presented the first of the modelling approaches for forecasting Australia's domestic LCC passenger demand, as measured by enplaned passengers and revenue passenger kilometres performed. As noted in Chapter 1 traditional or classical linear regression models have been the most popular forecasting method used in previous studies forecasting airline passenger demand. In this chapter, for the first time, two classical multiple linear regression (MLR) econometric models (PAX/RPKs) were developed and empirically tested the statistical relationship between key airline passenger demand-influencing factors and the corresponding level of Australia's domestic LCC passenger traffic, as measured by enplaned passengers and RPKs performed.

In this study, an extensive literature review has been undertaken to identify and justify the potential variables that influence air transport demand as can be seen in section 4.2. To determine which variables should be included into the MLR models, *t-statistics* and standard errors (*SE*) have been performed to ensure that all models have the most accurate, reliable, and highest predictive capability for forecasting Australia's domestic low cost carrier passenger demand.

Statistical measures for evaluating the models shows that the PAX and RPKs models found to be the most appropriate classical multiple linear regression models to forecast Australia's domestic LCC passenger demand are:

Domestic air travel demand (PAX)

$$PAX = -22977.26 - 16.49X_1 + 1.94X_2 - 212.58X_3 + 620.68X_4 - 4758.36X_5$$

Domestic air travel demand (RPKs)

$$RPKs = -29708.15 - 18.79X_1 + 2.39X_2 - 198.26X_3 + 632.05X_4 - 4981.65X_5$$

where

X_1 is Australia's real best discount airfare

X_2 is Australia's real GDP per capita

X_3 is Australia's real interest rates

X_4 is World jet fuel price

X_5 is dummy variable (Dummy 1) reflecting Virgin Australia changing business model

Both PAX and RPKs models are very good in terms of goodness-of-fit measures and model accuracy. The following chapter presents the first of three artificial intelligence-based forecasting methods, and specifies and tests two artificial neural networks models (ANNs) for forecasting Australia's domestic LCC passenger demand.

CHAPTER FIVE: FORECASTING DEMAND FOR AUSTRALIA'S LOW COST CARRIERS USING AN ARTIFICIAL NEURAL NETWORK APPROACH

5.1 Introduction

The previous chapter presented the first of Australia's domestic LCC demand forecasting models based on use of the classical or traditional linear regression approach. In the past, regression models have been generally used to forecast airline passenger traffic (see, for example, Abed et al. 2001; Aderamo 2010; Ba-Fail et al. 2000; Bhadra 2003; Kopsch 2012; Sivrikaya & Tunç 2013). This chapter takes an alternative approach and, for the first time, specifies and tests two artificial neural networks models (ANNs) for forecasting Australia's domestic LCC passenger demand. As noted in Chapter 1, ANNs have attracted considerable attention in the literature due to their predictive capabilities and quick learning. However, despite these advantages there have been few reported studies which have developed and tested ANNs for forecasting a country's domestic airline passenger demand. The notable exceptions being Alekseev and Seixas (2002, 2009) who developed ANNs for forecasting Brazil's domestic passenger demand. Blinova (2007) has also proposed an ANN to forecast the expansion of Russia's air transport network.

The chapter is organised as follows: in Section 5.2 is an overview of artificial neural networks (ANNs). This is followed by explanation of the architecture of artificial neural networks (Section 5.3), and the ANNs model evaluation measures in Section 5.4. Section 5.5 discusses the ANNs training and testing, whilst Section 5.6 presents an overview of the transfer function used in the study's ANNs. In Section 5.7 the ANNs modelling and the results are presented.

5.2 Artificial Neural Network Modelling: A Brief Overview

To briefly recap, artificial neural networks (ANNs) comprise simple elements operating in parallel and which are inspired by biological nervous systems. As in nature, the connections between elements largely determine the network function (Kunt et al. 2011, p.355). Artificial neural networks (ANNs) are biologically inspired computer programs designed to simulate the way in which the human brain processes information. According to Agatonovic-Kustrin &

Beresford (2000, p. 717) “ANNs are digitized models of a human brain, computer programs designed to simulate the way in which human brain processes information. ANNs learn (or are trained) through experience with appropriate learning exemplars just as people do, not from programming”. An artificial neuron²⁸ incorporates weights, a summing function, bias and an activation function (Akgüngör & Doğan 2009; Kunt et al. 2011).

An ANN is formed from many single units, artificial neurons or processing elements (PE), connected with coefficients (weights), which comprise the neural structure and are organised in layers. The power of neural computations comes from connecting neurons in a network. Each PE has weighted inputs, transfer function and one output. An artificial neuron is a basic operating unit to constitute the ANN. The ANN consists of three layers, that is, input, hidden, and output layers (Kunt et al. 2011; Tiryaki & Aydın 2014). The input layer consists of all input factors. Information from the input layer is then processed by the ANN with one or more hidden layers acting as intermediate layers between the input and output layers (Akgüngör & Doğan 2009).

An artificial neural network can be trained to perform a particular function through adjustment of the values of connections (weights) between elements (Kunt et al. 2011). In the late 1940s, Donald Hebb introduced the Hebbian learning rule which is one of the fundamental learning rules for ANNs. A number of other researchers, for example, Hopfield (1982), Kohonen (1988) and Rumelhart et al. (1986) developed various learning rules and artificial neural network architectures (Akgüngör & Doğan 2009). The ANN consists of an interconnected group of artificial neurons and processes information utilizing the connectionist approach to computation. When the received signals are sufficiently strong, the neuron is activated and emits a signal through the axon. This signal may be sent to another synapse and may activate other neurons. The complex structure of biological neurons is simplified through the use of artificial neurons (Akgüngör & Doğan 2009).

The behaviour of an artificial neural network is determined by the transfer functions of its neurons, by the learning rule or algorithm, and by the ANN architecture itself. The weights are the adjustable parameters and, in that sense, a neural network is therefore a parameterized system. The weighed sum of the inputs constitutes the activation of the neuron. The activation signal is passed through transfer function to produce a single output of the neuron. The transfer function introduces a degree of non-linearity to the ANN (Ghosch

²⁸ An *artificial neuron* is a computational model inspired by the natural neurons receiving signals through synapses located on dendrites (Akgüngör & Doğan 2009).

et al. 2005; Panizzo & Petaccia 2009; Wilson et al. 2002). During training, inter-unit connections are optimized until the error in predictions is minimized and the network reaches the specified level of accuracy. Once the network is trained and tested it can be provided with new input information to predict the output (Agatonovic-Kustrin & Beresford 2000, p. 717).

5.3 Artificial Neural Network Architecture

The ANN forecasting technique consists of training a computer to learn from substantial data based on the structure of human brain, using many simple processing elements (Haykin, 1999). Thus, artificial neural networks (ANNs) are a method of using computer software to classify and recognise patterns in given data (Momoh, 2012). ANNs capture the inherent information from a considered set of variables and learn from the existing data, even when noise is present (Garrido et al., 2014). Hence, no formulation or *a priori* model is required (Watts et al., 2008; Curcio and Jorio, 2013). A neural network can be trained to perform a particular function by adjusting the values of connections (weights) between elements (Kunt et al., 2011). During the training process, the ANN is able to detect complex relationships between the input and output data and perform the subsequent synthesis (Sineglazov et al., 2013, p. 10). Once the ANN has been trained on the sample of the given data-set, it can make estimations through the detection of similar patterns in future data (BaFail, 2004).

Furthermore, ANNs have the ability to detect similarities in inputs, despite a particular input not ever being seen previously. This property provides ANNs with excellent interpolation capabilities, particularly when the input data may not be exact, that is, noisy (BaFail, 2004).

The most general form of an artificial neural network used in forecasting is shown in the following equation:

$$Y = F [H1 (X), H2 (X) \dots, Hn(X)] + u \quad (5.1)$$

where, Y is a dependent variable, X is a set of explanatory variables, F and H 's are network functions, and u is a model error term (Ba-Fail 2004, p. 103).

As mentioned previously, the artificial neural network (ANN) model is characterized by a network of three layers: input, output and hidden layers which resemble the human body's

neural network (Lahmiri 2011; Mehrotra et al. 2000). Neural networks consist of large numbers of simple processing elements called neurons organized into several layers and interconnected with each other through synaptic weights. Synaptic weights represent the intensity of the interaction between every pair of neurons, and the activation functions calculate the potential of every neuron (Garrido et al. 2014; Martin del Bío & Sanz Molina 2006; Tiryaki & Aydın 2014).

The most widely used ANN type for forecasting is the *Multi-Layer Perceptron* (MLP) model (Claveria & Torra 2014; Garrido et al. 2014; Tiryaki & Aydın 2014). The MLP is a supervised neural network based on the original simple perceptron model. Figure 5.1 presents the study's 3-layer back propagation network (Lahmiri 2011; Mourani et al. 2006). The first layer is the input layer and corresponds to the problem input variables with one node for each input variable. The second layer is the hidden layer used to capture non-linear relationships among variables. The third layer is the output layer used to provide predicted values (Lahmiri 2011). The number of neurons in the input layer is equal to the number of input variables or independent variables, and the number of output neurons is equal to the number of output variable(s) or dependent variable(s). The input layer receives the initial values of the variables, the output layer shows the results of the network for the input, and the hidden layer carries out the operations designed to achieve the output (Tiryaki & Aydın 2014).

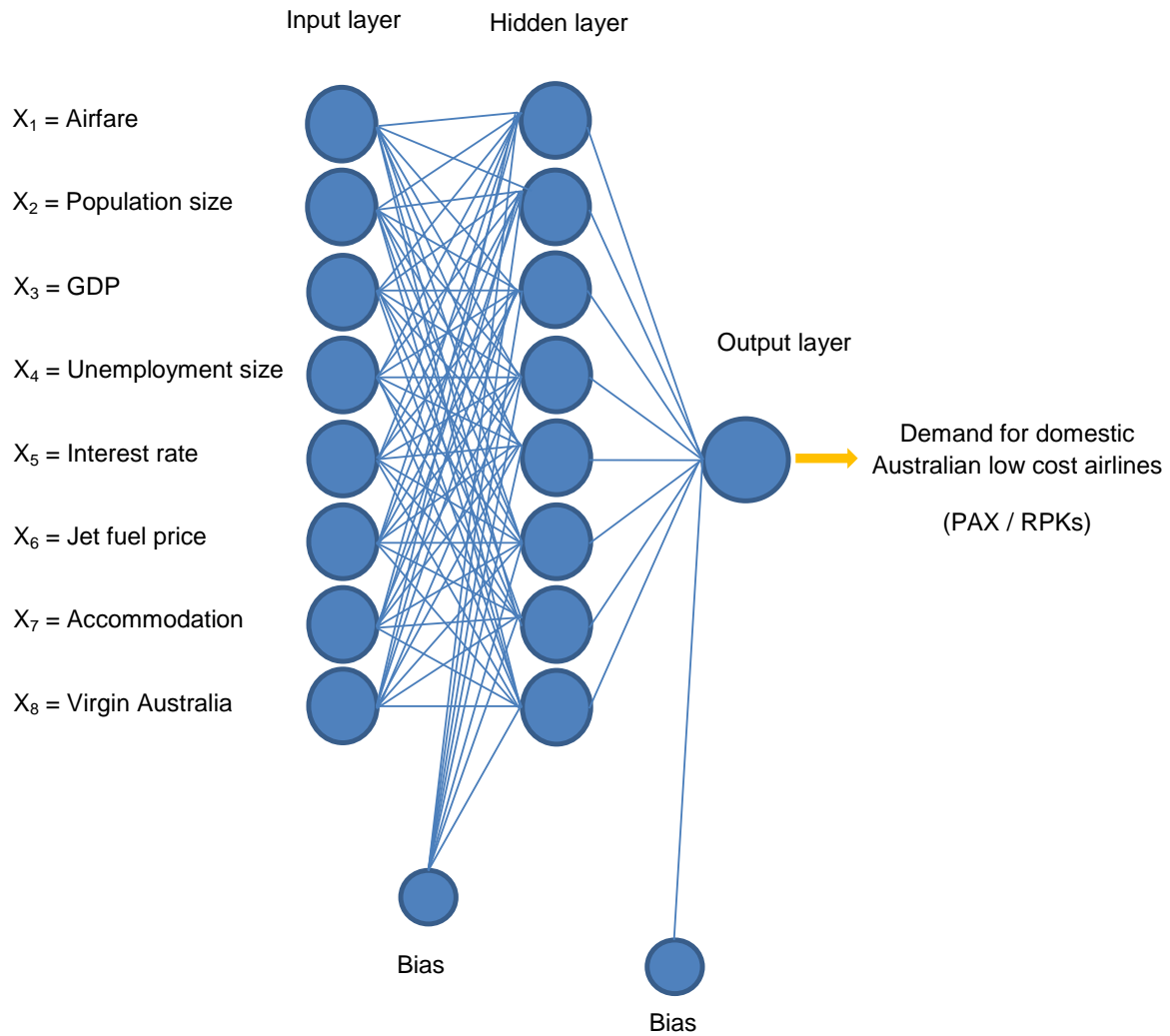


Figure 5.1. The artificial neural network (ANN) structure for forecasting Australia's domestic LCC passenger demand

The output of the MLP can be expressed in mathematical form as per the following equation:

$$Y = g(\theta + \sum_{j=1}^m v_j + [\sum_{i=1}^n f(W_{ij}X_i + \beta_j)]) \quad (5.2)$$

In Equation (5.2), Y is the forecast value of dependent variable; X_i is the input value of i th independent variable; W_{ij} is the weight of connection between the i th input neuron and j th hidden neuron; β_j is the bias value of the j th hidden neuron; v_j is the weight of connection between the j th hidden neuron and output neuron; θ is the bias value of output neuron; $g(\cdot)$ and $f(\cdot)$ are the activation functions of output and hidden neurons respectively (Tiryaki & Aydın 2014).

5.3.1 Artificial neural network Input variables and data sources

As noted in Figure 5.1 above, during the ANN models development process, eleven variables were tested as the inputs in the two ANN models (PAX and RPKs). These inputs comprised Australia's real GDP, Australia's real GDP per capita, Australia's real best discount air fares, Australia's population size, Australia's unemployment (size), Australia's tourist accommodation establishments recorded bed capacities (proxy for tourism attractiveness), world jet fuel prices, Australia's real interest rates and three dummy variables. The data sources are presented in Section 4.3 above.

5.4 Artificial Neural Network Model Evaluation

Similar to the multiple linear regression modelling, the ANN modelling also used goodness-of-fit statistics in order to measure the model's accuracy and reliability. According to Kunt et al (2011, p.356), "Goodness-of-fit (GOF) statistics are useful when comparing results across multiple studies, for examining competing models in a single study, and also for providing feedback on the level of knowledge about the uncertainty involved in the phenomenon of interest." Five measures were used in the present study: mean absolute error (MAE), mean absolute percentage error (MAPE), mean square error (MSE), the root mean square error (RMSE), and correlation coefficient (R) (Kunt et al. 2011; Ruiz-Aguilar et al. 2014; Tiryaki & Aydın 2014).

The *mean absolute error* (MAE) is a quantity used to measure how close forecasts are to the eventual outcomes (Waters 2014). The mean absolute error (MAE) is given Equation (5.3):

$$MAE = \frac{1}{N} \sum_{i=1}^N [|t_i - td_i|] \quad (5.3)$$

Where t_i is the actual value, N is the total number of data and td_i is the forecast value obtained by the neural network (Tiryaki & Aydın 2014, p.104).

The *mean absolute percentage error* (MAPE) is the average of the absolute per cent errors for each period (Autry et al. 2013).

$$MAPE = \frac{1}{N} \left(\sum_{i=1}^N \left[\left| \frac{t_i - td_i}{t_i} \right| \right] \right) \times 100 \quad (5.4)$$

Where t_i is the actual value, N is the total number of data and td_i is the forecast value obtained by the neural network (Tiryaki & Aydın 2014, p.104).

A standard error measure used to assess the forecasting accuracy of the ANN and MLR model is the *mean square error* (MSE). The definition of MSE is that the difference between the actual value and the forecast is determined, squared and then summed across all samples. The sum is then divided by the number of total data to get the MSE. The lower MSE values represent the more accurate prediction results. The MSE is defined as follows:

$$MSE = \frac{1}{N} \sum_{i=1}^N (t_i - td_i)^2 \quad (5.5)$$

Where t_i is the actual value, N is the total number of data and td_i is the forecast value obtained by the neural network (Tiryaki & Aydın 2014, p.104).

The *root mean square error* (RMSE) is an estimate of a standard deviation from the random component in data and is defined as Equation (5.6). The RMSE is a frequently-used measure of differences between values predicted by a model or an estimator and values actually observed (Kunt et al. 2011, p. 356).

$$RMSE = \sqrt{\frac{1}{N} \sum_{i=1}^N (t_i - td_i)^2} \quad (5.6)$$

Where t_i is the actual value, N is the total number of data and td_i is the forecast value obtained by the neural network (Tiryaki & Aydın 2014, p.104).

The *correlation coefficient* (R) matrix represents the normalized measure of the strength of the linear relationship between variables in a model. The correlation coefficients range from -1 to 1 , where values close to 1 suggest there is a positive linear relationship between data columns (Kunt et al. 2011, p. 356). The values close to -1 suggest one column of data has a

negative linear relationship to another column of data (*anticorrelation*), and the values close to or equal to 0 suggest no linear relationship exists between data columns (Bevington & Robinson 2002).

$$R = \frac{\sum_{i=1}^N (t_i - \bar{t})(td_i - \bar{td})}{\sqrt{\sum_{i=1}^N (t_i - \bar{t})^2 \cdot \sum_{i=1}^N (td_i - \bar{td})^2}} \quad (5.7)$$

Where t_i are the actual values, td_i is the forecast values, N is the total number of data, and \bar{td} is the average of the forecast values (Tiryaki & Aydın 2014, p. 104).

5.5 Training and Testing of the Artificial Neural Networks

Training is the algorithmic process in the hidden neuron where parameter weights can be adjusted appropriately to forecast accurately. Among various training algorithms, back-propagation is the most popular algorithm used in artificial neural networks (ANNs) (Ba-Fail 2004; Claveria & Torra 2014; Faraway & Chatfield 1998; Zhang 2004). The basic idea being to propagate a gradient of the transfer function back and compare actual output from output units with a target output, then re-adjust weights backward in the network. Weights are adjusted and repeated until the mean squared error (MSE) between network prediction and actual data is close to the target (Jung & Wang 2007; Tiryaki & Aydın 2014; Zhang 2004).

For the purpose of the training process, artificial neural networks are separated into three data sets: *training* is used for model fitting and selection, *testing* is used for evaluating the model's forecasting ability and *validation* data sets determine the end point for the training process to avoid model over fitting (Alekseev & Seixas 2009; Garrido et al. 2014; Tiryaki & Aydın 2014; Zhang et al. 1998). Indeed, over-fitting is a major concern with neural network model building (Remus & O'Connor 2001; Smith & Ragsdale 2010) as it can lead to predictions beyond the range of the training data (Jeon 2007). In order to avoid over-fitting models, the study's artificial neural network (ANN) design was carried out using three data sets: training, validation, and testing, which were randomly divided into a 70:15:15 ratio (Garrido et al. 2014; Kunt et al. 2011; Tiryaki & Aydın 2014). Importantly, a cross validation process was carried out during the training phase to avoid over-fitting the ANN models (Efendigil et al. 2009).

The objective of training is to minimize the global error such as root mean square error (RMSE), mean absolute error (MAE), mean square error (MSE), and mean absolute percentage error (MAPE). ANNs usually commence with randomized weights for all their neurons. This means that they do not know everything and therefore require training to solve a particular problem for which they are intended. When a satisfactory level of performance is reached, training is concluded and the network uses these weights to decide (Akgüngör & Doğan 2009).

The training set was used to adapt the synaptic weights of the multilayer network, utilising the back propagation of estimation errors (Haykin 1999). All inputs were inserted into the model and the networks trained. During the supervised learning process, an error function is defined. The synaptic weights values are iteratively updated until the provided output tends to be the desired, and the error function descends along the surface towards a local minimum. In this study the training process stopped when it reached 1,000 epochs or 0.01 error tolerance (Efendigil et al. 2009).

To conclude the training phase, a validation data set was used. The stopping criterion was the mean square error (MSE) of the estimated demand with respect to the samples belonging to the validation set. The validation set was not used in adapting the weight vectors of the neural estimator, and was therefore able to detect over-fitting in the training phase (Alekseev & Seixas 2009).

For estimating the generalization capacity of the ANN forecasting model, a testing set was also used (Alekseev & Seixas 2009). Thus, after the training process was completed, a testing process was applied to ensure the model accuracy was sufficiently reliable. Once the values of the training set were determined, a data testing set was fed into the model and the output compared to the target value. The model was accepted if the difference was low enough (Garrido et al. 2014). The testing set simulated forecasting of the samples (Alekseev & Seixas 2009).

Prior to training data in the ANN modelling, it is essential to transform all input into patterns. Training and testing vectors are also formed into patterns. Baseri (2011 p. 760) noted that “each pattern is formed with an input condition vector as well as the corresponding target vector”. Input and output data scaling is also an essential issue for consideration, particularly when process parameters’ operating ranges are diverse (Baseri 2011). Data normalization of

data determines that the system will be trained efficiently, and ensures that results are not skewed by particular variables (Baseri 2011).

In this study all data were therefore normalized prior to use in the training phase using Equation (5.8). Data normalization was applied to transform the data to a symmetric distribution which improves model performance since the data appear to more closely satisfy the assumptions of a statistical inference procedure also following the transformations of variables (Ghassemzadeh et al. 2013). Data is normalized using the following equation:

$$x_{norm} = a + \frac{(x-x_{min})(b-a)}{x_{max}-x_{min}} \quad (5.8)$$

Where x_{norm} is the normalized value, x is the actual value, x_{max} is the maximum value, and x_{min} is the minimum value, a and b are pre-specified range (Kalkhaheh et al. 2012).

There are several advantages of normalizing data prior to processing in the training stage. One advantage is to avoid attributes in greater numeric ranges dominating those of smaller data ranges. The second advantage is to avoid numerical difficulties experienced during the calculation (Mittal et al. 2012). With data normalization, the data are scaled so they fall within a pre-specified range, such as [-1, 1] (Mitsa 2010). In this study's modelling process, all data values were scaled in the range between -1 and 1 using Equation (5.8). A further advantage of normalizing the data is that normalization also removes any arbitrary effects of similarity between objects whilst also increasing the answer rate data to the input signal (Mittal et al. 2012).

The neural network process is summarized in Figure 5.2.

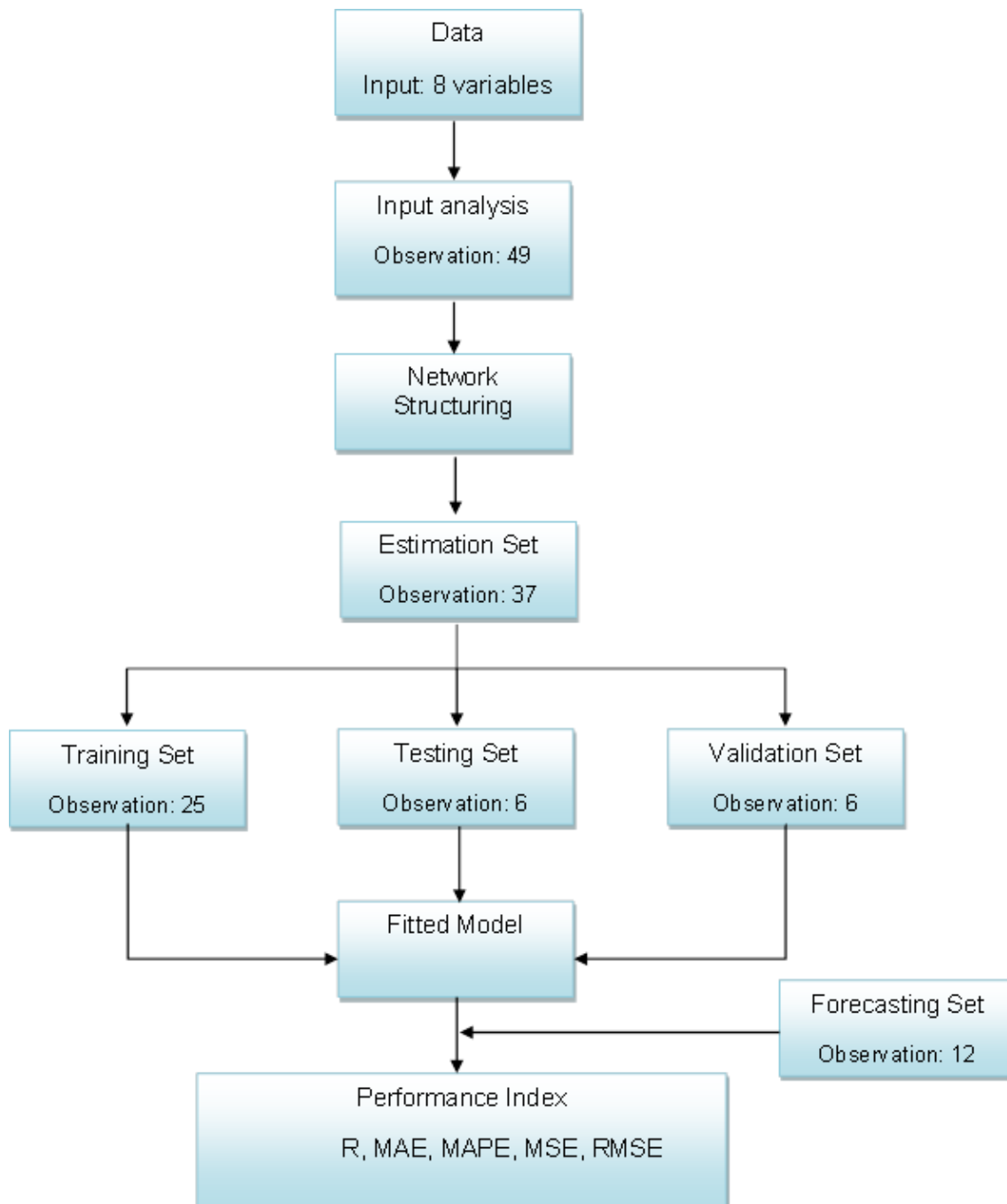


Figure 5.2. The artificial neural network (ANN) modelling process
Source: adapted from Jiang et al. (2004).

5.6 Artificial Neural Networks Transfer Function

The transfer function plays an important role in ANNs as it produces the output of the network. The transfer function or the activation in the hidden layer combines the inputs and

weights values to deliver a signal to the output (Terzic et al. 2012). This is usually a nonlinear function determining neuron output (Garrido et al. 2014; Tiryaki & Aydin 2014; Zhang 2003). The transfer or activation function typically falls into one of three categories:

- Linear (or ramp)
- Threshold
- Sigmoid (Terzic et al. 2012).

The most frequently used transfer function is the sigmoid or logistic function as it possesses favourable mathematics properties such as monotonicity, continuity, and differentiability, which are all important when training a neural network with gradient descent (Priddy & Keller 2005). An activation function is used as a boundary of output. These boundaries normally change from zero to one [0, 1] or from minus one to plus one [-1, +1] according to the type of activation function used in the ANN (Akgüngör & Doğan 2009).

This study used the sigmoid function in the hidden layer and the linear transfer function in the output layer. The Levenberg–Marquardt back propagation algorithm was used as the training algorithm since its convergence is stable and fast (Ruiz-Aguilar et al. 2014). The Neural Network tool box 8.0 within the framework of MATLAB R2012b (The MathWorks, Inc., USA.) software was used for modelling and simulation purposes.

5.7 Artificial Neural Networks Modelling Empirical Results

5.7.1 Structure of Final Models

Two different ANN models were developed to forecast Australia's domestic LCC passenger demand (enplaned passengers (PAX) and revenue kilometres performed (RPKs)). The MLP model consisted of three layers having weight matrix W , bias vector b and output vector p^i where $i > 1$. Figure 5.3 presents the optimum MLP model for predicting Australia's domestic LCC enplaned passenger traffic and RPKs. The number of each layer is shown as a superscript to the variable of interest. Following Kunt et al. (2011), superscripts were used to identify the source (second index) and destination (first index) for various weights and other elements of the network.

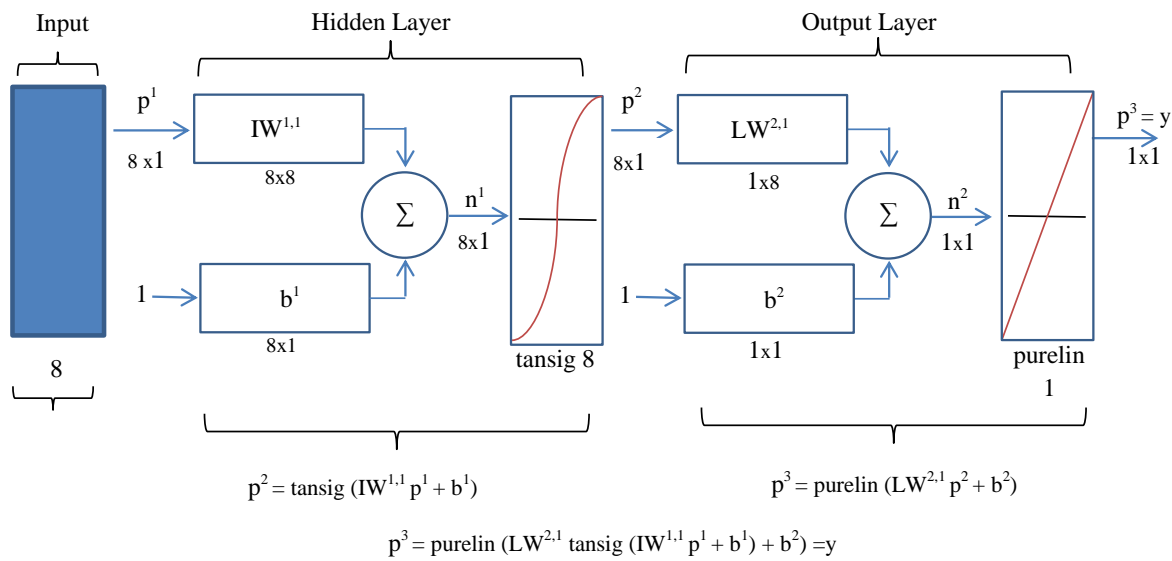


Figure 5.3. The structure of the final Australia's domestic LCC passenger demand multi-layer perceptron artificial neural network model
Source: adapted from Kunt et al. (2011, p. 358).

The weight matrix connected to input vector p^1 was labelled as input weight matrix ($IW^{1,1}$). The elements of layer 1, such as its bias, net input and output have superscript 1 to indicate they were associated with the first layer (Kunt et al. 2011).

The matrices of layer weight (LW) and input weight (IW) were utilised in the MLP model. Data were randomly divided into three parts: training, testing, and validation (Alekseev & Seixas 2009; Kunt et al. 2011). The MLP model had 8 inputs, 8 neurons in the hidden layers and 1 neuron in the output layer. The output layer of the MLP model consisted of one neuron representing Australia's domestic LCC enplaned passengers (PAX) or RPKs values, respectively. As noted earlier, 70 per cent of the data were used in the training phase. Validation and testing data sets each contained 15 per cent of the original data.

Constant input 1 was fed to the bias of each neuron. The outputs of each intermediate layer were the inputs to the subsequent layer. Hence, layer 2 can be analysed as one-layer having 8 inputs, 1 neuron and 1 X 8 weight matrix W^2 . The layer can be treated as a single-layer network in its own right. The layers of a MLP play different roles in the prediction process (Kunt et al. 2011). The back propagation algorithm was applied to determine errors and modification for the weight of the hidden layer neurons (Akgüngör & Doğan 2009). In this

study, p^3 was the network output of interest and has been labelled as y (Rumelhart et al. 1986).

The objective of this network is to reduce error e , which is the difference between t and p^i in which $i > 1$ and t is the target vector. The perceptron learning rule calculates desired changes (target output) in the weights and biases of the perceptron, given input vector p^1 and the associated error e . Accordingly, the Least Mean Square Error (LMS) algorithm adjusts the weights and biases of the linear network so as to minimize this mean square error (Kunt et al. 2011).

The error at output neuron j at iteration t can be calculated by the difference between the desired output (target output) and the corresponding real output, $e_j(t) = d_j(t) - y_j(t)$. So, Equation (5.9) is the total error energy of all output neurons.

$$\varepsilon(t) = \frac{1}{2} \sum_{j \in c} e_j^2(t) \quad (5.9)$$

Referring to Figure 5.3, the output of the k -th neuron in the l -th layer can be calculated by Equation (5.10) in which $f_2 = \log \text{sig}$ and $f_3 = \text{purelin}$:

$$y_k^l = f_k \left(\sum_{j=1}^{n^{l-1}} w_{jk}^l \cdot y_j^{l-1} \right) \quad (5.10)$$

where $1 \leq l \leq 3$, n^l refers to the number of neurons in layer l . For the input layer thus holds $l=1$, $y_j^1 = x_j$, for the output layer $l=3$, $y_j^3 = y_j$.

The mean square error (MSE) of the output can be computed by:

$$E = \frac{1}{2} (d_j - y_j)^2 = \frac{1}{2} [d_j - f_3(\sum_{i=1}^8 w_{jk}^3 \cdot y_j^2)]^2 \quad (5.11)$$

The steepest descent of MSE can be used to update weights by Equation (5.12) (Yeung et al. 2010):

$$w_{ij}^3(t+1) = w_{ij}^3(t) - \eta \frac{\partial E}{\partial w_{ij}^3} \quad (5.12)$$

The MSE performance index for an ANN is a quadratic function as shown in Equation 5.11. Hence, the performance index will either have one global minimum, a weak minimum or no minimum, depending upon the characteristics of input vectors (Kunt et al. 2011). Specifically, characteristics of input vectors determine whether or not a unique solution exists (Hagan et al. 1996).

The performance of the ANN can be increased if relevant information is extracted to feed the network. Here, the ANN can evaluate correlations of such intelligent variables in the original input data space. Considering all available information and following the extensive literature review on the predictors of air transport demand, additional input variables, previously identified but not used in the econometric analysis due to statistical insignificance, were considered for feeding the input nodes of the neural estimator in conjunction with existing variables (Alekseev & Seixas 2009). Additional vector components included: Australia's unemployment size, Australia's tourist accommodation establishments recorded bed capacities (proxy for tourism attractiveness), plus 2 dummy variables, accounted for the loss of capacity following the collapse of Ansett Australia in 2001 (DUMMY 2) and accounted for the impact of the Commonwealth Games held in Melbourne in March 2006 (DUMMY 3).

As previously mentioned, Australia's unemployment size and Australia's tourist accommodation establishments recorded bed capacities (proxy for tourism attractiveness) were not included in the PAX and RPKs multiple linear regression models estimated in Chapter 4 due to statistical insignificance. However, Abed et al. (2001), Cook (2007) and Wensveen 2011 have observed that interest rates are a potential economic factor influencing air travel demand. Therefore, this variable was tested as an input in the ANN models. Consequently, there were two forms of the artificial neural networks (ANNs) architecture examined in the study. The first ANN network did not include Australia's real interest rates. In contrast, the ANNs network that included Australia's real interest rates in the network proved to be more accurate and reliable forecasting models. The number of neurons in the hidden layer ranged from 5 to 9, and 1 output neuron (in both the PAX or RPKs models).

The MLP architecture which presented the best forecasting accuracy was therefore comprised of 8 inputs, 8 neurons in the hidden layer and 1 output neurons (in abbreviated form, 8-8-1 architecture for both PAX and RPK models)

5.7.2 Results of Final Models

The final ANN PAX and RPKs models in this study comprised 8 inputs, 8 neurons in the hidden layers and 1 neuron in the output layer. The estimated weights for various sections of the PAX and RPKs models are presented in Figures 5.4 to 5.9, respectively. Panel A presents the connections estimated weights from the inputs (X_1 to X_8) and $Bias_{H1}$ to the hidden unit H_1 . Similar to Panel A, Panel B to Panel H presents a similar diagram for the connections estimated weights from the inputs (X_1 to X_8) and $Bias_{Hn}$ to the hidden unit H_n . Panel I presents the estimated weights between the 8 hidden units and the output units (Gonzalez, 2000).

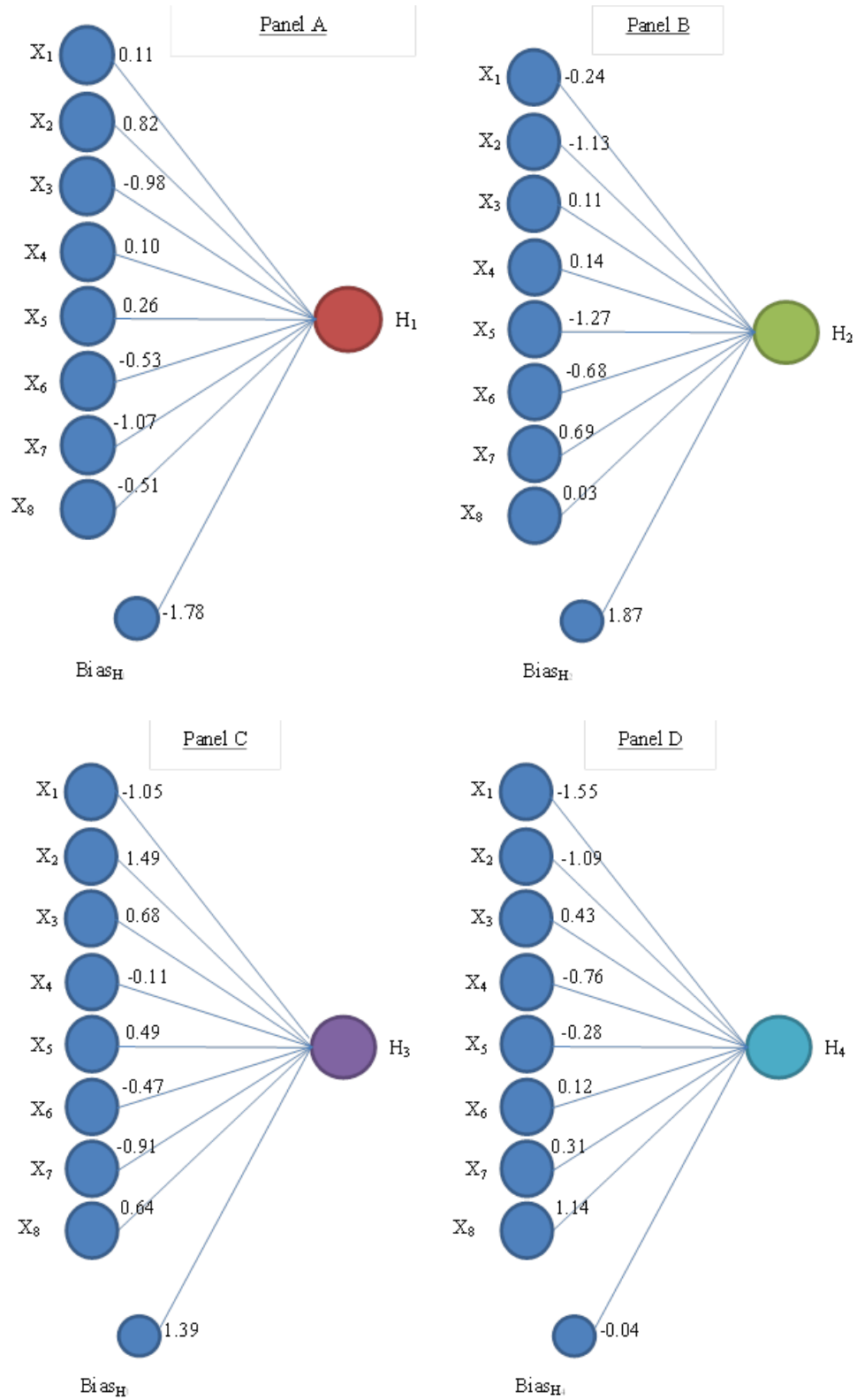


Figure 5.4. Estimated weights of PAX model (Panel A to Panel D)

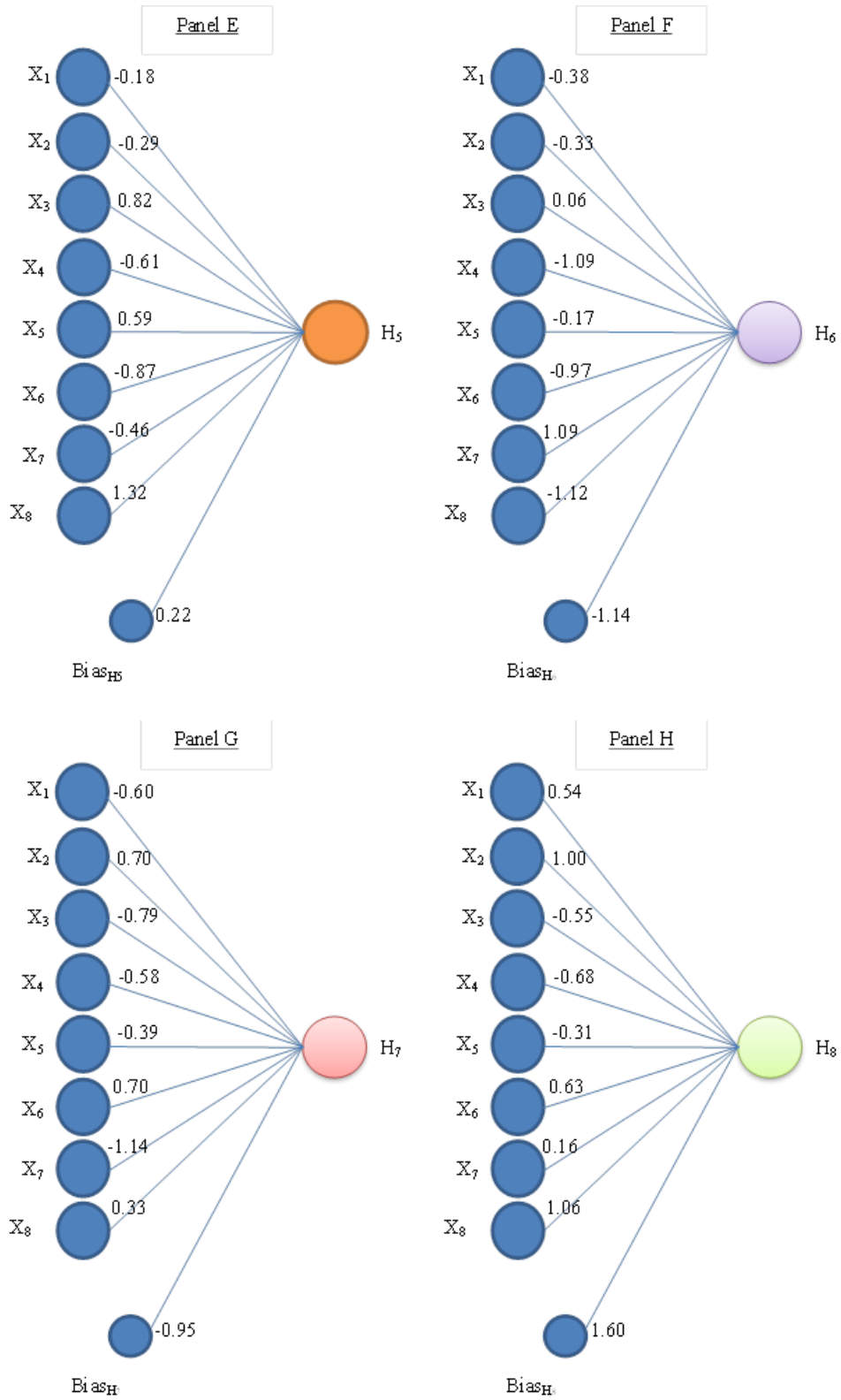


Figure 5.5. Estimated weights of PAX model (Panel E to Panel H)

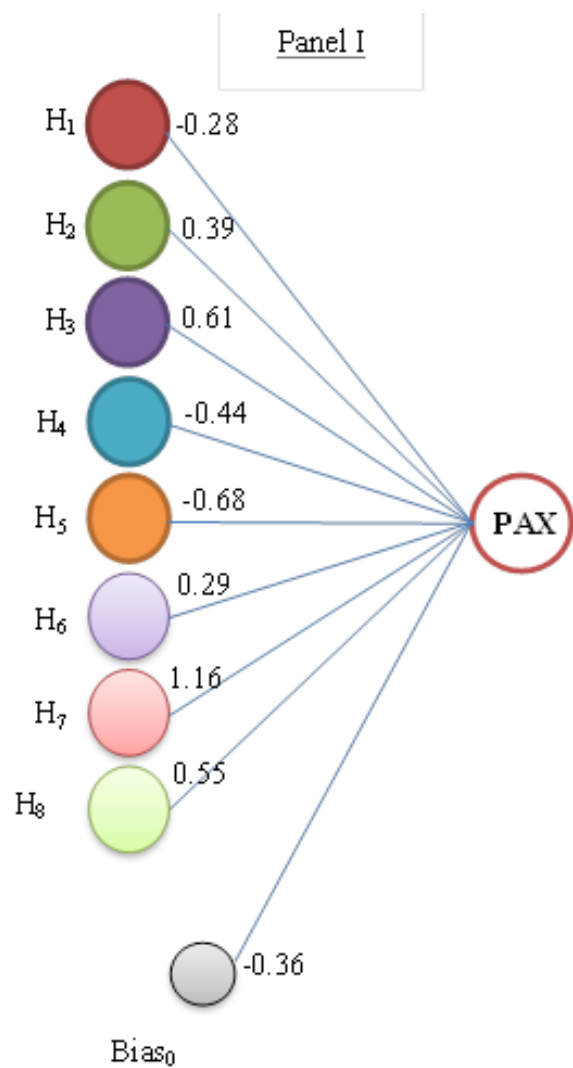


Figure 5.6. Estimated weights of PAX model between the hidden units and the output unit

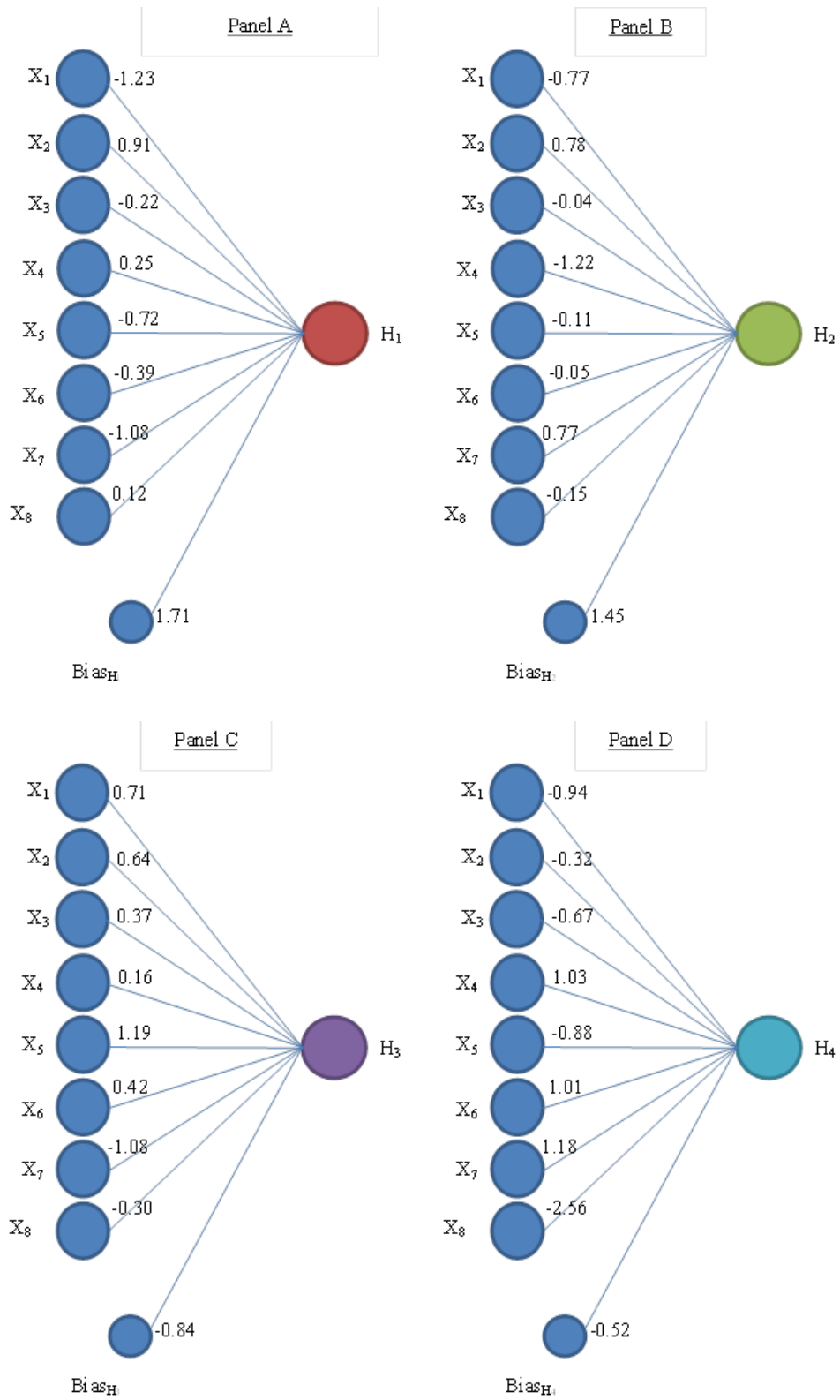


Figure 5.7. Estimated weights of RPKs model (Panel A to Panel D)

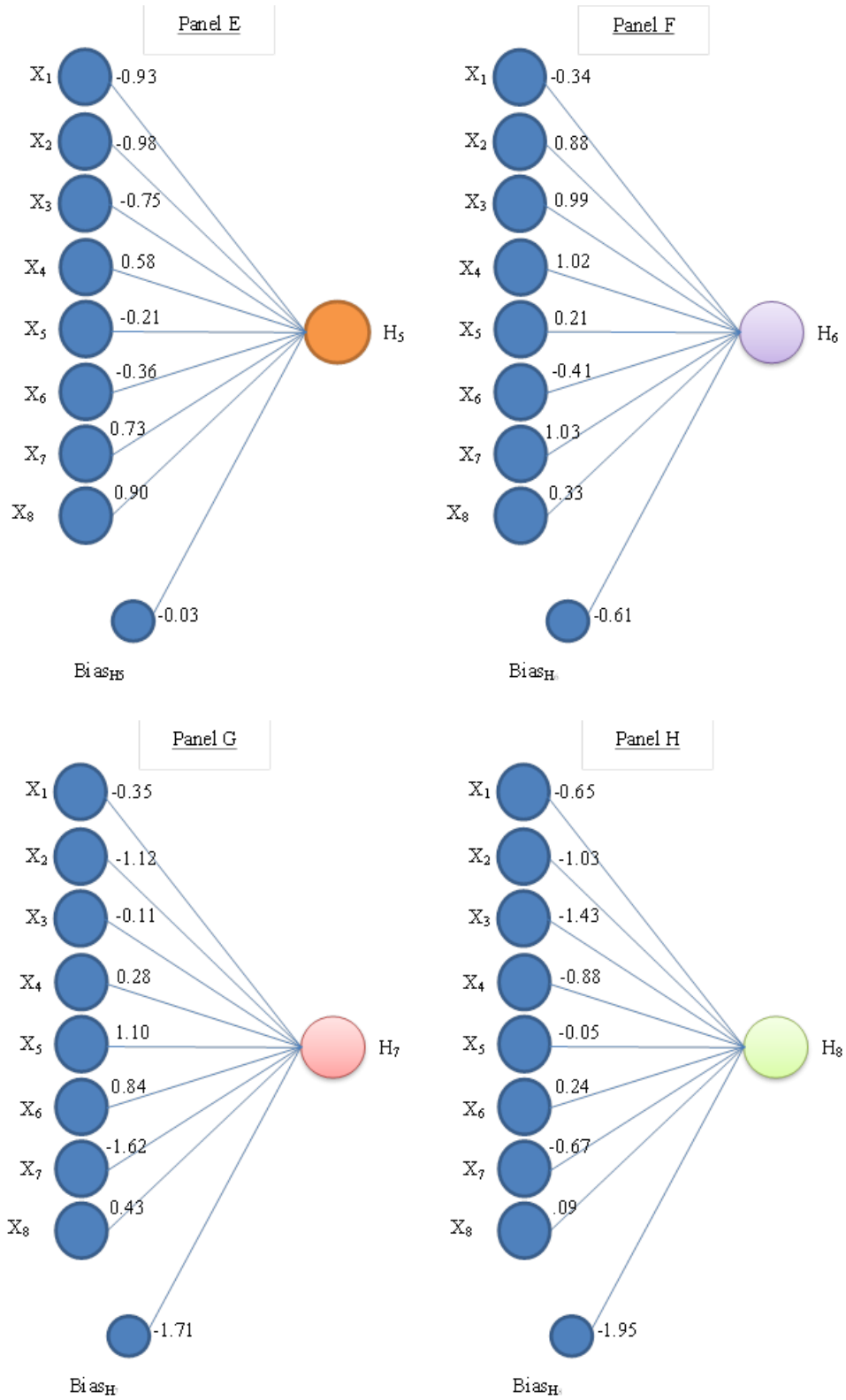


Figure 5.8. Estimated weights of RPKs model (Panel E to Panel H)

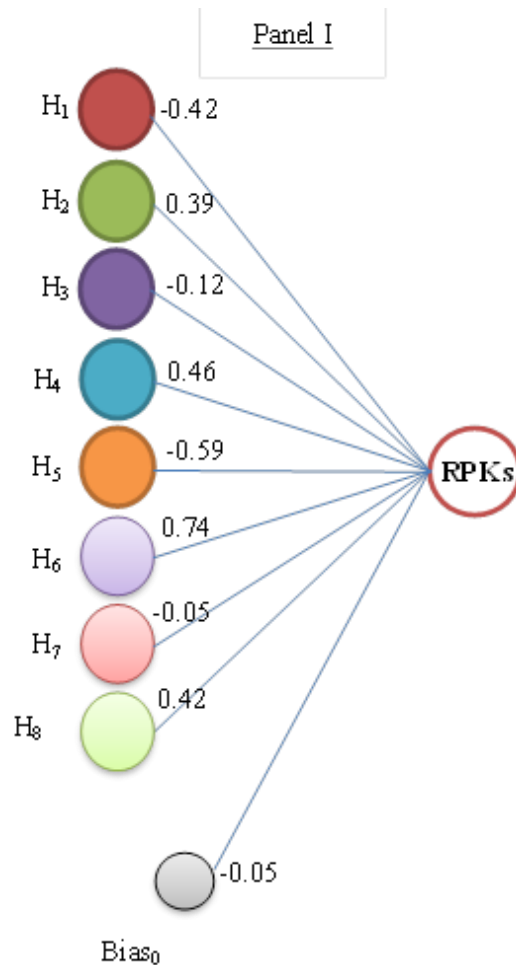


Figure 5.9. Estimated weights of RPKs model between the hidden units and the output unit

The forecasting PAX and RPKs ANN models are presented in the following equations:

$$PAX = -0.36 - 0.28 H_1 + 0.39 H_2 + 0.61 H_3 - 0.44 H_4 - 0.68 H_5 + 0.29 H_6 + 1.16 H_7 + 0.55 H_8$$

$$RPKs = -0.05 - 0.42 H_1 + 0.39 H_2 - 0.12 H_3 + 0.46 H_4 - 0.59 H_5 + 0.74 H_6 - 0.05 H_7 + 0.42 H_8$$

Where: X_1 = Airfare; X_2 = Australia's population size; X_3 = Australia's real GDP; X_4 = Australia's unemployment size; X_5 = Australia's real interest rates; X_6 = World jet fuel prices; X_7 = Australia's tourist accommodation establishments; X_8 = Dummy variable for Virgin Australia changing business model; H_n = network hyperbolic tangent sigmoid activation function:

$$H_n = \text{TANH}(Z_n) = \frac{(e^{Z_n} - e^{-Z_n})}{(e^{Z_n} + e^{-Z_n})} \quad (5.13)$$

Where Z_n is calculated by multiplying the value of each input by the corresponding weight (w_i) (Eq.5.14) (Gonzalez, 2000).

$$Z_n = \text{Bias}_{H_n} + w_1 X_1 + w_2 X_2 + w_3 X_3 + w_4 X_4 + w_5 X_5 + w_6 X_6 + w_7 X_7 + w_8 X_8 \quad (5.14)$$

The results of the ANN PAX and RPKs MLP models are presented in Table 5.1 in the form of a forecasting table, and show the forecast level of Australia's domestic LCC passenger demand (as measured by RPKs and enplaned passengers, respectively) during training, testing, and validation phases.

Table 5.1. Forecasting accuracy of Australia's domestic LCC passenger demand artificial neural networks (ANN) MLP models

<i>R</i>	Model 1 (PAX)	Model 2 (RPKs)
Training	0.9952	0.9999
Validation	0.9922	0.9956
Test	0.9889	0.9944
All	0.9914	0.9954

Figure 5.10 shows regression plots of the ANN PAX model output with respect to training, validation and testing data. The value of the correlation coefficient (R) for each phase was also calculated (Kunt et al. 2011). The R value was around 0.9914 for the total response in the MLP model. The solid lines in Figure 5.10 shows the perfect linear fit between actual values and forecast values of Australia's domestic LCC enplaned passengers (PAX) model. The correlation coefficient (R) between actual values and forecast values is another important indicator to check the validity of the model. Importantly, when the R value is close to 1, forecasting accuracy increases (Tiryaki & Aydın 2014).

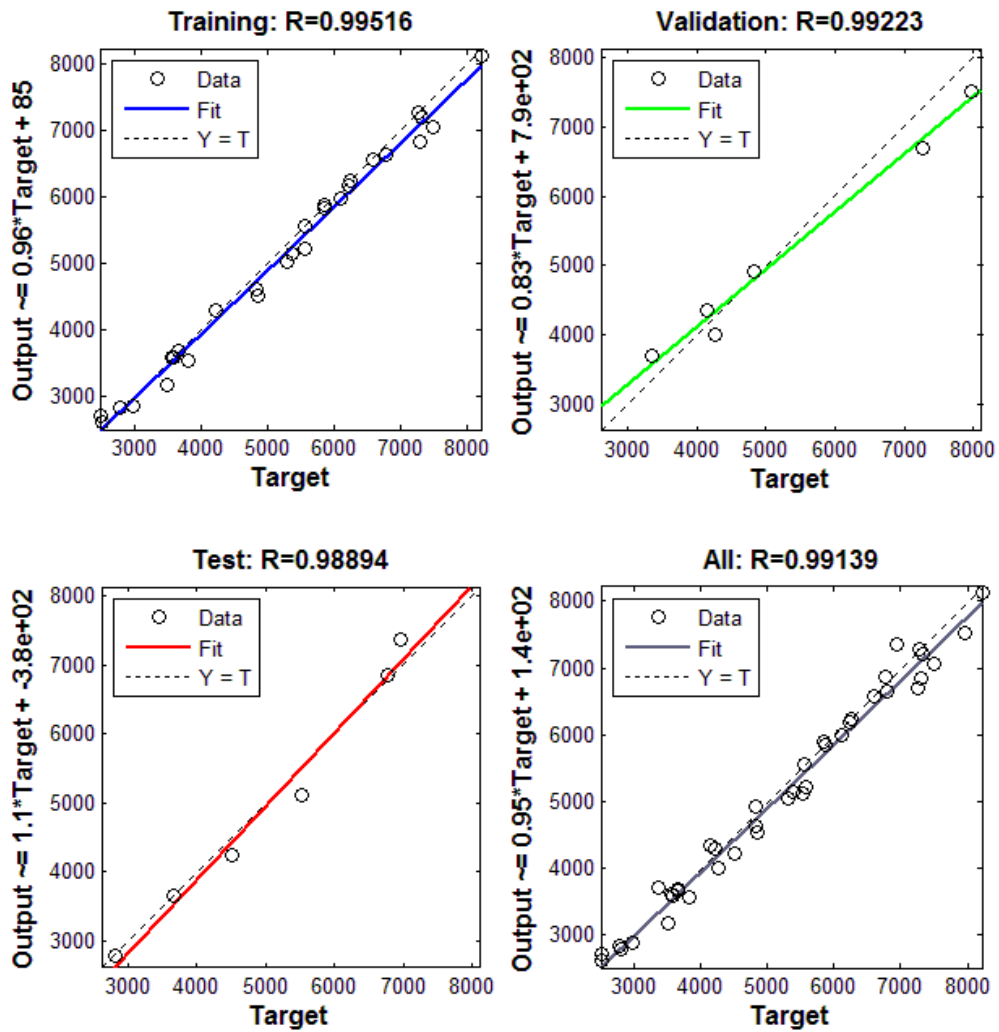


Figure 5.10. Regression plots for training, testing and validation phases and the total response in Australia's domestic LCC passenger demand ANN PAX MLP model

The relationship between actual values and forecast values obtained in the ANN RPKs model is shown in Figure 5.11. The R value was around 0.9954 for the total response in the RPKs ANN MLP model.

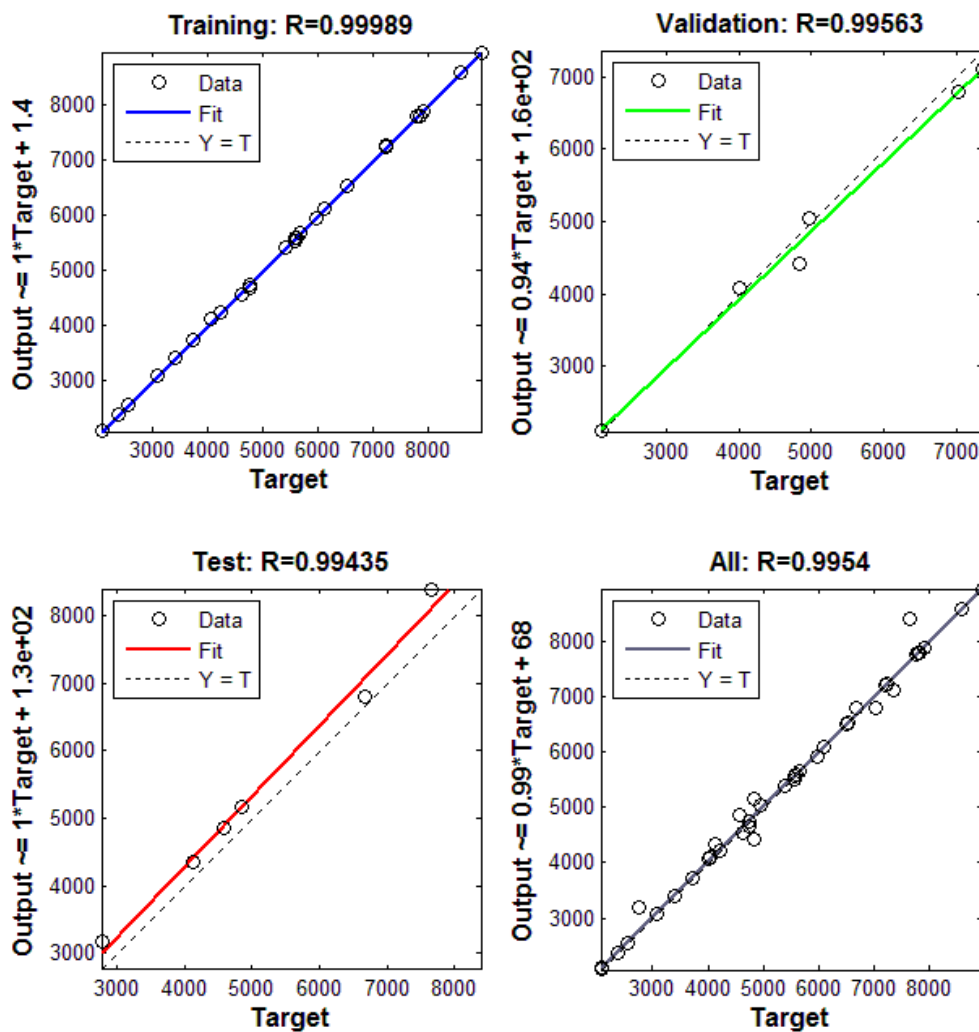


Figure 5.11. Regression plots for training, testing and validation phases and the total response in Australia's domestic LCC passenger demand ANN RPKs MLP model.

Training errors, validation errors and testing errors were plotted to determine validation errors in the training phase for both the PAX and RPKs models. The best validation performance in the PAX model occurred at epoch 9 with MSE at 1.3×10^5 (Figure 5.12). The plot in Figure 5.12 shows the MSE commencing at a larger value and decreasing to a smaller value, which indicates network learning is improving. The plot in Figure 5.12 has three lines, because 37 input and target vectors were randomly divided into three sets (Garrido et al. 2014; Kunt et al. 2011). 70 per cent of the vectors were used for training the network. 15 per cent of the vectors were used for validating how well the network model was generalised. Training vectors continue for as long as it takes for training to reduce the network error on validation vectors. After the network has memorized the training set, training concludes. This technique automatically avoids the problem of over-fitting the model,

which plagues many optimization and learning algorithms (Kunt et al. 2011). As previously noted, the training process stopped when it reached 1,000 epochs or 0.01 error tolerance (Efendigil et al. 2009).

To forecast the generalization capacity of the study's PAX and RPKs ANN forecasting models, a testing set comprising the remaining 15 per cent of the vectors was used. This set was only presented to the neural estimator following conclusion of the training, and hence it did not participate in the training phase (Alekseev & Seixas 2009).

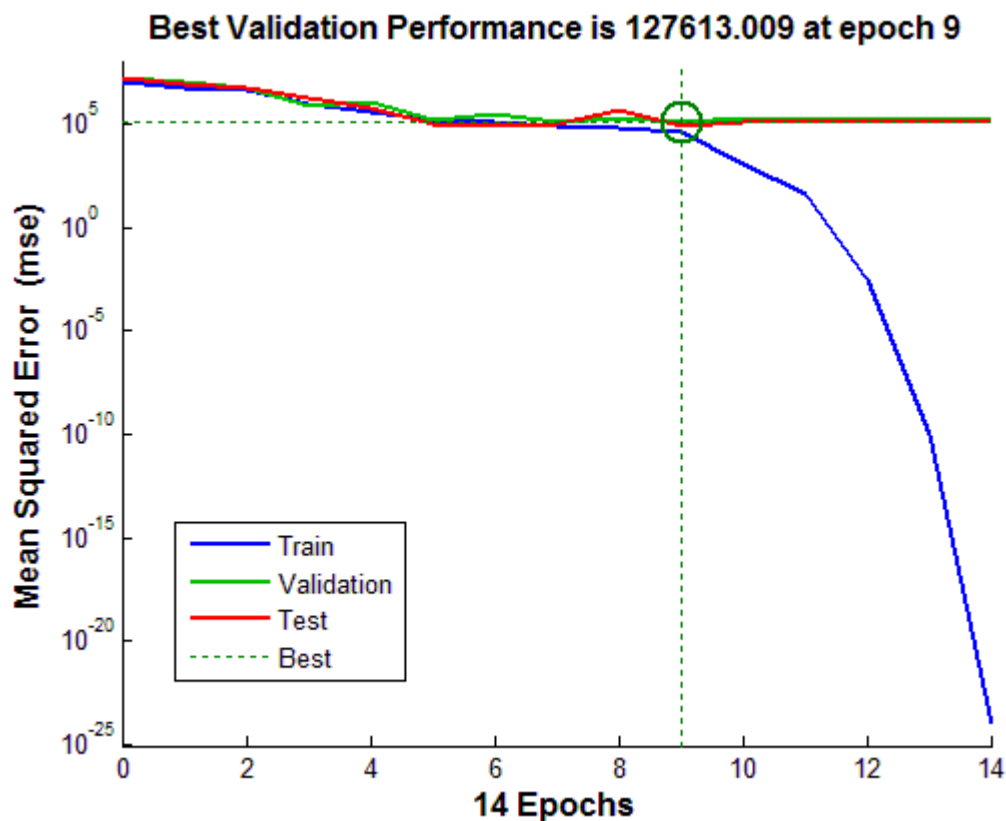


Figure 5.12. The validation error in Australia's domestic LCC passenger demand ANN PAX model

The ANN RPKs model's training errors, validation errors and testing errors were also plotted to find the validation error in the training phase. The best validation performance in the model occurred at epoch 14 with MSE at 4.9×10^4 (Figure 5.13). Similar to Figure 5.12 (PAX model), the plot shows a decrease in the MSE of the network which indicates network learning is improving.

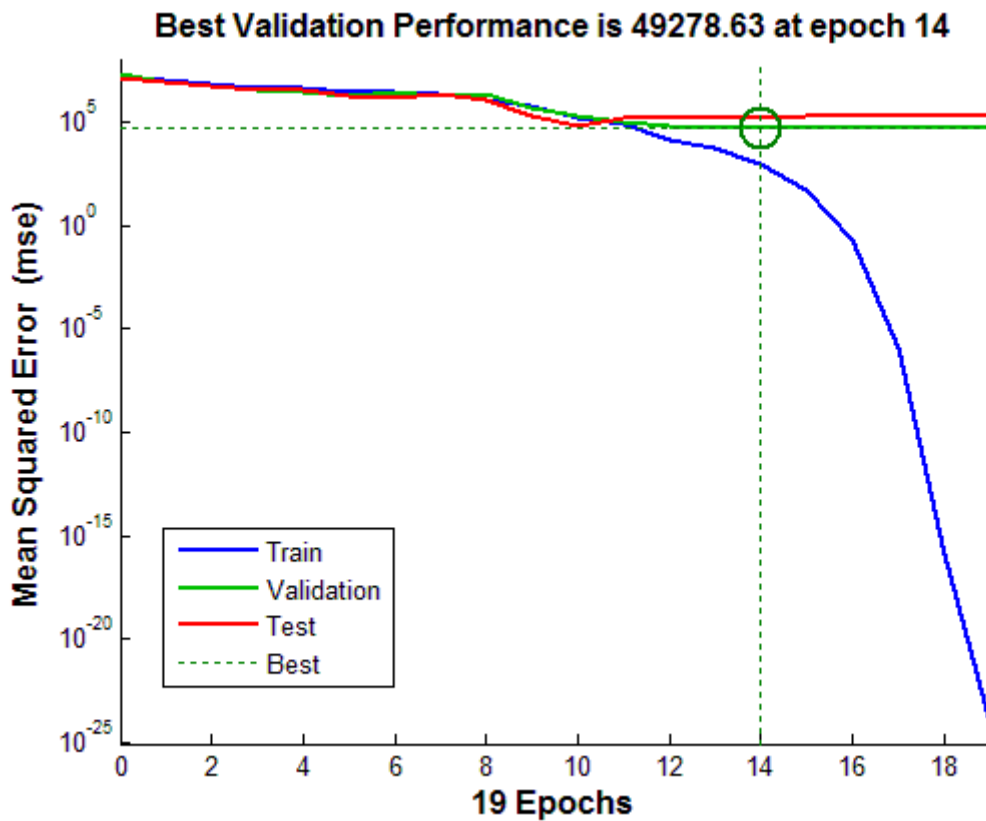


Figure 5.13. The validation error in Australia's domestic LCC passenger demand ANN RPKs model

The performance index of training, testing and overall data of the ANN PAX and RPKs models were calculated with the results being shown in Table 5.2. Both the PAX and RPKs models show that MAE, MAPE, MSE, RMSE values are very low for training, testing and overall data sets²⁹.

²⁹ It is observed that the performance index such as MAE, MAPE, MSE and RMSE, show better results for the estimating data than for the testing data set. This is because the testing data set or out of sample data set is the "new data" which has not participated in the building model and it is used to test the "true" performance of forecasting model. While the training data set is used for constructing a forecasting model and it has been seen by the model. Hence, a model's performance on the training data set will generally be better than the model's performance on non-training data set (Michalewicz et al 2006).

Table5.2.Performance index of ANN PAX and RPKs models for training, testing and overall data sets

Performance index	PAX Model			RPKs Model		
	Train data	Test data	Overall data	Train data	Test data	Overall data
MAE	182.66	232.00	194.74	200.99	219.08	205.42
MAPE	3.61%	4.91%	3.93%	3.95%	5.73%	4.39%
MSE	6.3×10^4	1.1×10^5	7.4×10^4	7.3×10^4	8.5×10^5	7.6×10^4
RMSE	251.19	327.74	271.93	269.83	292.11	275.45

Australia’s actual domestic LCC and forecast enplaned passengers during Quarter 1 2002 to Quarter 1 2014 are plotted and shown in Figure 5.14.

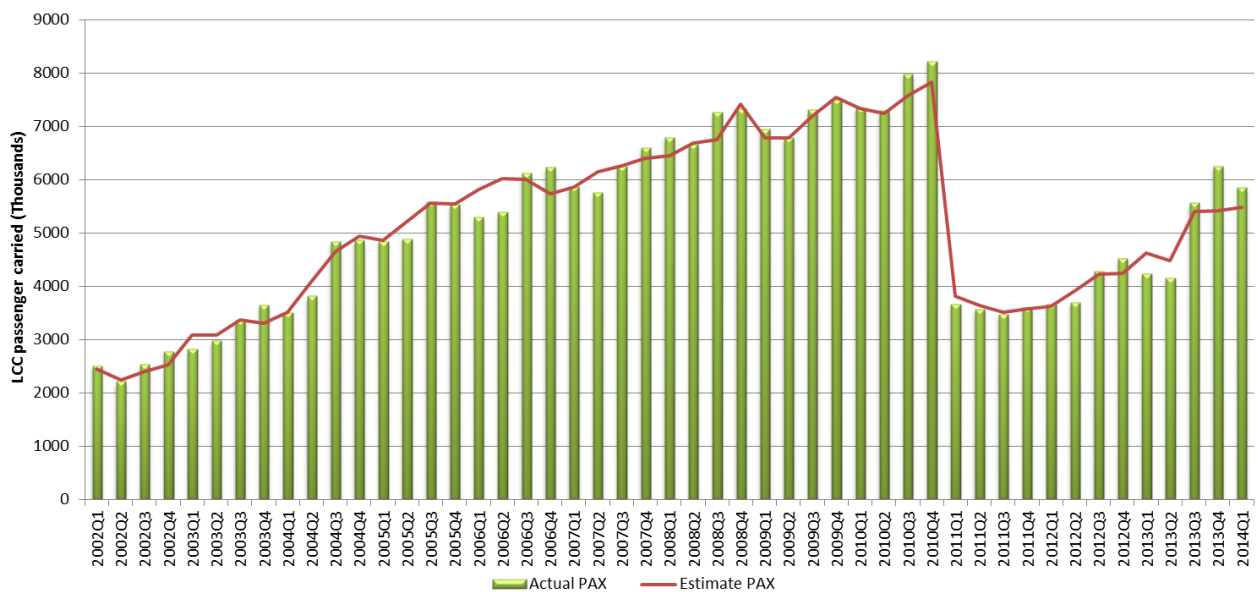


Figure5.14.A comparison of Australia’s domestic LCC actual and forecast enplaned passengers (ANN Model)

Australia’s domestic LCC actual domestic revenue passenger kilometres (RPKs) and forecast RPKs from Quarter 1 2002 to Quarter 1 2014 are plotted and shown in Figure 5.15, indicating the accuracy of the model’s estimations.

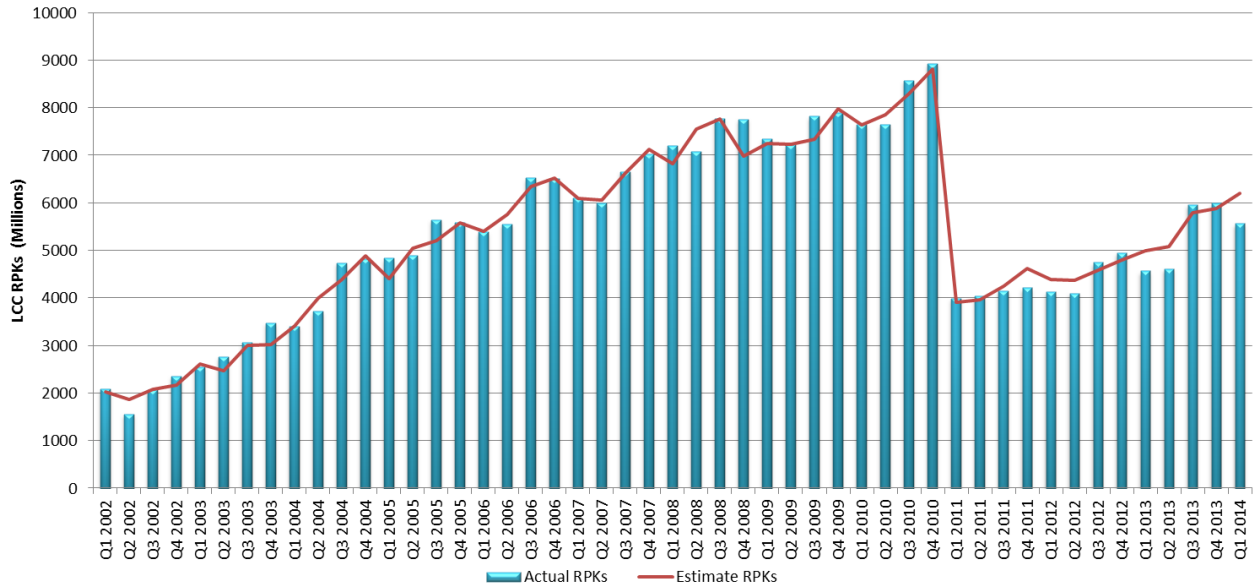


Figure 5.15. A comparison of Australia's domestic LCC actual and forecast RPKs (ANN Model)

5.7.3 Discussion of Contributing Factors that influence Australia's domestic LCC passenger demand

This study used a contribution table (Gately, 1996) to analyse the major contributing factors that influence Australia's domestic LCC passenger demand and revenue passenger kilometres performed (RPKs). The contribution of factor (C_i) in the input layer is the sum of absolute values of the weight of connection between the input neuron and the hidden neuron.

$$C_i = \sum_{j=1}^k |W_{ij}| \quad (5.15)$$

where

C_i is the contribution value of factor i

W_{ij} is the weight of connection between the i th input neuron and j th hidden neuron.

The scale of contributing factor developed by Gately (1996) was used to evaluate the influences of input variables. Base on this scale, any input variable with a contribution value less than 2 is considered a weak contributing factor while any input variable with a contribution value greater than 5 is considered a high contributing factor (Chen et al., 2012).

Table 5.3 shows the contribution value of input variables for the PAX and RPKs models. It can be seen that all input variables in both PAX and RPKs models have a contribution value higher than 2 which means that no input variables are considered a weak contributing factor. Also, the three most important input variables for forecasting PAX are X_2 Australia's population size, X_8 Dummy variable for Virgin Australia change business model, and X_7 Australia's tourist accommodation bed spaces (proxy for tourism attractiveness), while X_7 tourist accommodation bed spaces, X_2 Australia's population size, and X_1 Australia's real best discount air fares are the three most important factors for forecasting RPKs. As can be observed in Table 5.3, Australia's real interest rates also have a contribution value of 3.75 and 4.48 in PAX and RPKs models, respectively.

Table 5.3. The contributions of input variables

Input variables	PAX model	RPKs model
X_1 Airfare	4.64	5.92
X_2 Population	6.84	6.66
X_3 GDP	4.42	4.59
X_4 Unemployment size	4.07	5.42
X_5 Interest rates	3.75	4.48
X_6 Jet fuel price	4.97	3.73
X_7 Tourist ³⁰ accommodation bed spaces	5.82	8.16
X_8 Dummy variable for Virgin Australia changing business model	6.15	4.89

As previously noted, the final two ANN models have 8 inputs: Australia's real GDP, Australia's real best discount air fares, Australia's population size, Australia's unemployment numbers, Australia's tourism attractiveness, Australia's real interest rates, world jet fuel prices and one dummy variable for Virgin Australia changing business model. Several different models were developed and tested using Australia's real GDP per capita as the measure of the effect of income on Australia's domestic LCC passenger demand or

³⁰ In this thesis, a *tourist* is defined as a temporary visitor staying at least 24 hours in a region for the purpose of leisure (holidays, recreation, sport), business, family (visiting friends or relatives) , or attending conferences or meetings (Reisinger 2009, p. xviii).

alternatively Australia's real GDP and population size. The ANN modelling results showed that the inclusion of Australia's real GDP and population size provided higher forecasting accuracy than the models using Australia's real GDP per capita. The importance of Australia's real interest rates as a driver of domestic LCC passenger demand was also tested in the modelling. This was to the best of the author's knowledge the first time that this relationship had been tested. The modelling results showed that the inclusion of Australia's real interest rates was a factor that influenced Australia's domestic LCC passenger demand. The findings therefore support Cook (2007) and Wensveen (2011) who have noted that interest rates can influence air travel demand.

In order to test the relationship between Australia's domestic LCC passenger demand and tourism, the models were tested with and without the Australia's tourism attractiveness variable. The results clearly showed that the inclusion of Australia's tourism attractiveness variable in the models resulted in greater predictive capability and robustness. In order to test the impact of jet fuel prices on Australia's domestic LCC passenger demand, real world jet fuel prices (expressed in Australian dollars) were included in the modelling. World jet fuel prices were used as a proxy due to the absence of Australia's jet fuel prices data set for the study period. The modelling results showed that world jet fuel prices do influence Australia's domestic LCC passenger demand and their inclusion in the models also resulted in the models greater predictive capability and robustness.

5.7.4 Comparison of results with previous ANN-based domestic air passenger demand forecasting studies

As noted earlier, there have been two reported studies that have used an artificial neural network approach to forecast airline passenger demand (Alekeseev and Seixus 2002, 2009; Blinova 2007). The following table shows a comparison between these two previous studies and the current study. It is clearly shown that the current study has utilised a large number of data points than previous studies. It is generally advised that a large sample size should be used to obtain sufficient learning in training stage. While only one performance index was applied in the previous studies, the current study utilized five performance indexes which are R-value, MAE, MSE, MAPE, RMSE to ensure the predictive capability, and robustness of the models.

Table 5.4.A comparison between the two previous studies and present study

	Alekseev and Seixus 2002, 2009	Blinova 2007	Present study
Region of study	Brazil (Domestic)	Russia (Domestic)	Australia (Domestic LCC)
Output	Passenger kilometres	Passenger numbers	Passenger numbers and Revenue passenger kilometres (RPKs)
Number of Input variables	5	28	8
Data Frequency	Annual (1978-1997)	Annual (1992-2005)	Quarterly (Quarter 1 2002 to Quarter 2 2014)
Data points	20	14	49
Performance index	Mean relative error	Relative forecasting error	<i>R</i> -value/MAE/MSE/ MAPE/RMSE

5.8 Summary

In light of the reported advantages of artificial neural networks (ANNs) as a forecasting tool, and in the absence of any previous reported studies that have proposed and tested artificial neural networks (ANNs) to predict Australia's domestic LCC passenger demand, this study used an artificial neural network with multi-layer perceptron architecture (MLP) to predict Australia's domestic LCC passenger demand using input parameters. The ANN models output were measured by explained passengers (PAX Model) and revenue passenger kilometres performed (RPKs Model).

The ANN was applied for training, testing and validation and contained eight inputs and eight neurons in the hidden layer and one neuron in the output layer. 70% of the data was used in the training phase with the remaining data divided into validation (15%) and testing (15%). The *R*-value of Model 1 (PAX) was around 0.9914 and Model 2 (RPKs) was 0.9954, respectively.

The main contribution of this study was to forecast Australia's domestic LCC passenger demand at a national level using an ANN approach. The results show that the artificial neural network's performance provided high prediction accuracy in forecasting both Australia's domestic LCC passenger demand and revenue passenger kilometres performed (RPKs). Whilst the factors that influence air travel demand are complex, the results of the present study showed that the significant factors influencing Australia's domestic LCC passenger demand are Australia's real GDP, Australia's population and unemployment size, Australia's real best discount air fares, Australia's real interest rates, world jet fuel prices, and Australia's tourism attractiveness.

The three most important input variables for forecasting Australia's domestic LCC passenger demand are Australia's population size, Dummy variable for Virgin Australia change business model and Australia's tourist accommodation bed spaces (proxy for tourism attractiveness), while the three most important factors for forecasting RPKs are tourist accommodation bed spaces, Australia's population size, and Australia's real best discount air fares. Australia's population size and tourist accommodation bed spaces are found to be the input variables in both PAX and RPKs models with the contribution value of 6.84 and 5.82 in the PAX model and 6.66 and 8.16 in the RPKs model, respectively.

A further contribution of the study was the greater understanding of the influence of tourism attractiveness and real interest rates on air travel demand as these two socio-economic factors were shown to be an important predictor variable in the ANN models. The contribution value of these variables were 5.82 and 3.75 in the PAX model and 8.16 and 4.48 in the RPKs model, respectively.

The following chapter explores another artificial intelligence-based modelling approach then proposes and tests a new genetic algorithm (GA) model for Australia's domestic LCC passenger demand. Chapter 7 develops and empirically examines a new adaptive neuro-fuzzy inference network model (ANFIS) for forecasting Australia's domestic LCC passenger demand.

CHAPTER SIX: FORECASTING AUSTRALIA'S LOW COST CARRIER PASSENGER DEMAND USING A GENETIC ALGORITHM

6.1 Introduction

The genetic algorithm is a further approach applicable to forecasting and optimization problems (Kunt et al. 2011). Despite their growing use as a forecasting method in a growing range of disciplines, no reported study has proposed a genetic algorithm approach for forecasting airline passenger demand. Accordingly, this chapter proposes and empirically tests a new genetic algorithm approach for forecasting Australia's domestic LCC passenger demand.

The chapter is structured as follows: Section 6.2 presents a brief overview of genetic algorithm. Section 6.3 examines the genetic algorithm process. The proposed genetic algorithm is presented in Section 6.4. The genetic algorithm modelling results are presented in section 6.5.

6.2 Genetic Algorithm: A Brief Overview

According to Akgüngör and Doğan (2009, p.137), "genetic algorithms (GAs) are based on the genetic process of biological organisms that are explained by the principles of natural selection and survival of the fittest ones". GAs therefore resemble the natural evolutionary processes wherein a population of a species adapts to its natural environment, leading to a population of designs developing and then continuing to evolve so as to adapt gradually to the design environment being considered (Azadeh et al. 2011, p.2226). Ozturk et al. (2005, p.1005) further stated that "GAs encode a possible solution to a specific problem on simple chromosome string like data structure and apply specific operators to these structures so as to preserve important information".

The principal strength of GAs is their adaptive and self-organizing capabilities. These abilities enable GAs to quickly solve difficult problems through three evolutionary mechanisms: (1) selection, (2) crossover, and (3) mutation (Hu 2002).

The basic operations of GAs include selection, a crossover of genetic information between reproducing parents and a mutation of genetic information which affect the binary strings characteristic in natural evolution (Ozturk *et al.* 2005). If GAs are suitably encoded, then they can be used to solve real world problems by mimicking this process (Akgüngör, Doğan 2009).

6.3 Genetic Algorithm Process

The GA commences with a population of solutions (chromosomes), which is termed population, represented by coded strings (typically 0 and 1 binary bits) as the underlying parameter set of the optimization problem (Kunt *et al.* 2011). Each individual in the population is called a chromosome and these represent the candidate solution to the problem at hand (Gen, Cheng 1997). GAs generates successively improved populations of solutions (better generations) by applying three main genetic operators: selection, crossover and mutation (Amjadi *et al.* 2010; Coelho *et al.* 2014; Kunt *et al.* 2011).

With a GA it is a requirement to create an initial population to serve as the starting point. This population can be created randomly or by using specialized, problem specific, information on the specific problem being investigated (Godinho, Silva 2014, p. 395; Hurley *et al.* 1998). Over a wide range of applications, an initial population size of between 30 and 100 has often been used (Goldberg 1989). Chromosomes evolve through successive iterations, which are termed generations (Gen, Cheng 1997). During each generation the chromosomes are evaluated, using some measures of fitness (Ozturk *et al.* 2005). To create the following generation, new chromosomes, called offspring, are formed by (1) merging two chromosomes from a current generation using a cross-over operator, or (2) by modifying a chromosome using a mutation operator (Gen, Cheng 1997, p. 2). A new generation is formed by (1) selecting, according to fitness values, some of the parents and the offspring whilst (2) rejecting others so to keep the population size constant. Fitter chromosomes have a higher probability of being selected. Following several generations, the algorithms converge to a good population, which should contain the optimal or sub-optimal (close to optimal) solution to the problem at hand (Gen, Cheng 1997, p. 2).

The GA works with operations that are performed based on fitness evaluation. The fitness indicates the goodness of design, and, accordingly, the objective function is a logical choice

for the fitness measure (Ozturk *et al.* 2005). Fitness evaluation involves defining an objective or fitness function against which each chromosome is tested for suitability for the environment that is being considered in the study (Hurley *et al.* 1998). The GA selects the fittest members of the population based upon the best fitness value.

The *fitness function*, (that is, minimum sum of squared errors (SSE) $F(x)$), is presented as following

$$F_i(x) = \min_s \sum_j^m s_j (t_i - td_i)^2 \quad (6.1)$$

where t_i and td_i are the actual and estimated value, respectively, m is the number of observations, and $s=\{S_j\}$ is the vector of weighting factors (Ozturk *et al.* 2005, p. 1007). The GA process is illustrated in Figure 6.1.

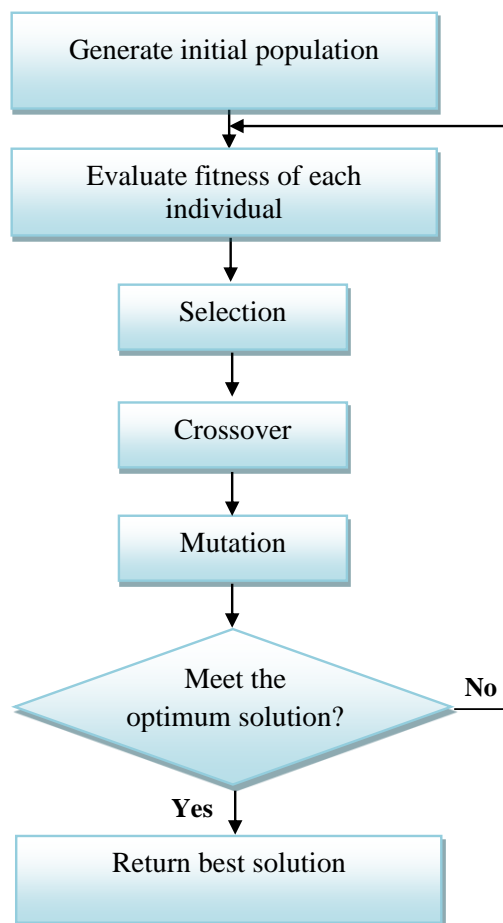


Figure6.1.Genetic algorithm process
Source: adapted from (Amjadi *et al.* 2010, p.494).

GAs work according to selection rules as defined by the laws of evolutionary genetics (Ozturk *et al.* 2005). The *selection* function chooses parents for the next generation based on their scaled values from the fitness scaling function in which the stochastic uniform selection function was used (Kunt *et al.* 2011). The selection mechanism consists of algorithms that mimic natural selection and select the best combination from a set of competing solutions. These selection algorithms (for example, rankings) yield preferences for the best performers (Hu 2002).

When using a GA, it is a requirement to select chromosomes from the current population for reproduction. The selection procedure picks out two parent chromosomes based on their fitness values, where the better the fitness value, the higher the probability that a chromosome is selected by the GA. The parent chromosomes are subsequently used by the crossover and mutation operators to produce two offspring for the new population. This selection/crossover/mutation cycle is repeated until the new population contains $2n$ chromosomes. This means the process stops after n cycles (Hurley *et al.* 1998, p. 502).

Crossover is achieved by exchanging coding bits between two mated strings in the GA (Kunt *et al.* 2011). Once a pair of chromosomes has been selected, crossover can then occur in order to produce offspring (Hurley *et al.* 1998). This operation is executed by selecting two mating parents, randomly selecting two sites on each of the chromosomal strings, and subsequently swapping the strings between the sites among the pair (Ozturk *et al.* 2005). Thus, parents produce offsprings having different genetic structures that include some mix of their chromosomes set (Akgüngör, Doğan 2009). An illustration of the crossover operation is as follows (Ozturk *et al.* 2005):

Parent 1 = 1010101011

Parent 2 = 1001000111

Child 1 = 1010000111

Child 2 = 1001101011

The crossover process is repeated from one generation to another until one individual dominates the population or until the predetermined numbers of generations are reached. Conversely, crossover is not normally applied to all pairs of individuals selected for mating (Akgüngör, Doğan 2009). The crossover operation is carried out with a probability p_c . Typical probability values range from 0.2 to 0.8 (Ozturk *et al.* 2005, p. 1006).

The *mutation* operation serves a critical role in GAs either through the replacement of genes lost from the population during the selection process or by providing genes that were not included in the initial population (Akgüngör, Doğan 2009). In GAs, the mutation operator is invoked with a low probability (p_m) at a randomly selected site on chromosomal string of the randomly chosen design. The operation consists of a switching of a 0–1 or vice versa (Ozturk *et al.* 2005, p. 1006). Mutation is therefore randomly applied with a small probability, which is typically in the range between 0.001 and 0.01 and modifies genes in the chromosomes. The effect of mutation on a binary string is illustrated as follows (Akgüngör, Doğan 2009):

Offspring	10101110 1101010
Mutated Offspring	10101110 0101010

6.4 The Genetic Algorithm Models for Forecasting Australia’s Domestic LCC Passenger Demand

6.4.1 The GAPAXDE and GARPXSDE data and variables selection

In this chapter, Australia’s domestic LCC enplaned passenger (GAPAXDE) and Australia’s domestic LCC revenue passenger kilometres performed (RPKs) (GARPXSDE) genetic algorithm models have been proposed and empirically tested. During the models development process and based on an extensive literature review of the factors that influence air travel demand, eight variables were considered for inclusion and testing as independent variables in the two GA models: Australia’s real GDP, Australia’s real GDP per capita, Australia’s real best discount air fares, Australia’s population size, Australia’s unemployment size, Australia’s tourism attractiveness (tourist accommodation

establishments recorded bed capacities), world jet fuel prices, and Australia's real interest rates.

Three dummy variables were also included for consideration in the GA models. The first dummy variable (DUMMY 1) explained the impact of the evolving Virgin Australia business model from an LCC to a FSNC business model on Australia's domestic LCC traffic (enplaned passengers and RPKs). As noted previously, Australia's LCC traffic in Australia has decreased significantly since 2011 primarily due to this transition in Virgin Australia's business model. Thus, the dummy variable reflecting the Virgin Australia changing business model (DUMMY 1) is zero for the period from Quarter 1 2002 to Quarter 4 2010 and one for otherwise.

The second dummy variable (DUMMY 2) accounted for the loss of capacity following the collapse of Ansett Australia (Prideaux 2003). The third dummy variable (DUMMY 3) accounted for the impact of the Commonwealth Games held in Melbourne from 15 to 26 March, 2006.

6.4.2 The GAPAXDE and GARPXSDE genetic algorithm process

The goal is to determine an optimal (or close to optimal) subset of K independent variables (chosen from a set of n independent variables $\{x_i : i = 1, 2, \dots, n\}$) which collectively provide the best predictive model of a dependent variable y . Two models will be considered:

$$\hat{y} = \sum_{i=1}^n w_i a_i x_i \quad (\text{linear model}) \quad (6.2)$$

$$\hat{y} = \sum_{i=1}^n w_i a_i x_i + \sum_{i=1}^n \sum_{j=1}^i w_{ij} a_{ij} x_i x_j \quad (\text{quadratic model}) \quad (6.3)$$

The coefficient component w_i indicates whether the variable x_i is included in the model, where $w_i = 1$ if x_i is included, and $w_i = 0$ if x_i is not included. Similarly, w_{ij} indicates whether the variable product $x_i x_j$ is included in the quadratic model. In what follows we will

denote the vector of weight values as \mathbf{w} , and define the set of feasible weight vectors $W_K = \{\mathbf{w} : \mathbf{w} \cdot \mathbf{1} = K\}$.

Once \mathbf{w} is specified, the values of $\{a_i : i = 1, 2, \dots, n\}$ (also $\{a_{ij} : i = 1, 2, \dots, n, j = 1, 2, \dots, i\}$ for the quadratic model) are chosen to minimise the squared difference between observed values of the dependent variable over m observations $\{y_i : i = 1, 2, \dots, m\}$, and corresponding forecast values $\{\hat{y}_i : i = 1, 2, \dots, m\}$ (i.e. least squares). That is, denoting the vector of model coefficients as \mathbf{a} , we minimise

$$LS(\mathbf{a} | \mathbf{w}) = \sum_{i=1}^m (y_i - \hat{y}_i)^2. \quad (6.4)$$

Objective function

The goal is to determine the weight vector \mathbf{w}^* such that

$$\mathbf{w}^* = \arg \min_{\mathbf{w} \in W_K} \left[\min_{\mathbf{a}} LS(\mathbf{a} | \mathbf{w}) \right] \quad (6.5)$$

Genetic Algorithm

If the number of independent variables, n , is large, then the number of variable combinations of size K will also be large. Specifically, the number of combinations will be

$\binom{n}{K}$ for the linear and quadratic models, and $\binom{\frac{n^2 + 3n}{2}}{K}$ for the quadratic model. This may

make it prohibitive to exhaustively evaluate all linear models with K independent variables. One possible approach to determining a close to optimal set of independent variables is to utilise a meta-heuristic algorithm such as a genetic algorithm.

The stages of the genetic algorithm are outlined as follows:

1. Generate an initial population

An initial population P_0 is generated by randomly selecting a set of M solutions from the feasible solution set W_K . For each member $\mathbf{w} \in P_0$ of the initial population we define the measure of fitness $F(\mathbf{w})$ to be

$$F(\mathbf{w}) = \min_{\mathbf{a}} LS(\mathbf{a} | \mathbf{w}). \quad (6.6)$$

2. Breed new population members for next generation

A pre-specified number B of new population members are bred at each generation. To breed each new population member we first choose two distinct parents from the existing population P_{i-1} with probabilities weighted by the inverse of the fitness measure F (i.e. lower values of F are associated with better solutions). That is, the probability of choosing solution $\mathbf{w} \in P_{i-1}$ for breeding each new solution is given by

$$\Pr(\mathbf{w}) = \frac{\frac{1}{F(\mathbf{w})}}{\sum_{\mathbf{w}_j \in P_{i-1}} \frac{1}{F(\mathbf{w}_j)}}. \quad (6.7)$$

Once the parents \mathbf{w}_1 and \mathbf{w}_2 are chosen, the child solution \mathbf{w}_c is bred using the following rules:

1. If $\mathbf{w}_1(i) = \mathbf{w}_2(i) = 1$, then $\mathbf{w}_c(i) = 1$ (i.e. any variable/variable product existing in both parent solutions is passed on to the child solution).
2. The remaining variables/variable products in the child solution (i.e. to make up a total of K) are randomly chosen from those where $\mathbf{w}_1(i) = 1, \mathbf{w}_2(i) = 0$ or $\mathbf{w}_1(i) = 0, \mathbf{w}_2(i) = 1$.
3. With probability p_{mut} (user specified), a breeding mutation occurs in which a randomly chosen variable/variable product which does not exist in either parent will exist in the child.

3. Introduce new migrating population members

At each new generation a set of G new population members migrate into the population. These new population members are generated randomly in the same way as members of the initial population.

4. Eliminate existing population members

To maintain a constant population size, a total of $B + G$ members of the existing population must then be discarded. Members are chosen with probabilities weighted by the fitness measure F (that is, higher values of F are associated with worse solutions), although the best solution is protected from elimination. The probability of choosing solution $\mathbf{w} \in P_{i-1}$ for elimination is given by

$$\Pr(\mathbf{w}) = \frac{F(\mathbf{w})}{\sum_{\mathbf{w}_j \in P_{i-1}} F(\mathbf{w}_j)}. \quad (6.8)$$

5. Form new population

The next population P_i is formed by combining the remaining (non-eliminated) population members from P_{i-1} with the new solution we bred and migrated into the population. Steps 2 to 5 are repeated for a predefined number of cycles, or until a pre-specified number of generations pass without improvement.

6.4.3 Model Evaluation Goodness of Fit Measures

Goodness-of-fit (GOF) statistics are useful when comparing results across multiple studies, for examining competing models in a single study, and also for providing feedback on the level of knowledge about the uncertainty involved in the phenomenon of interest (Kunt et al., 2011). Four measures were used in the present study, mean absolute error (MAE), the root

mean square error (RMSE), mean square error (MSE) (Yetilmezsoy et al., 2011) and mean absolute percentage error (MAPE) (Azadeh et al., 2010; Chen et al., 2010).

For evaluating the GA models, the Root Mean Squared Error (RMSE), mean absolute error (MAE), the mean absolute percentage error (MAPE), AND mean square error (MSE), were calculated using Equation (6.9) – Equation (6.12):

$$RMSE = \sqrt{\frac{1}{N} \sum_{i=1}^N (t_i - td_i)^2} \quad (6.9)$$

$$MAE = \frac{1}{N} \sum_{i=1}^N \left[\left| \frac{t_i - td_i}{t_i} \right| \right] \quad (6.10)$$

$$MAPE = \frac{1}{N} \left(\sum_{i=1}^N \left[\left| \frac{t_i - td_i}{t_i} \right| \right] \right) \times 100 \quad (6.11)$$

$$MSE = \frac{1}{N} \sum_{i=1}^N (t_i - td_i)^2 \quad (6.12)$$

where t_i is the actual values td_i is the predicted values, N is the total number of data points (Tiryaki and Aydın, 2014, p. 104).

6.5 The GAPAXDE and GARPXSDE modelling results

To estimate model parameters data was divided into training and testing datasets. The training data set is used to estimate the weighting factors (W_i) of the GA models and the testing data set is saved for testing purposes. The testing procedure is applied to obtain a minimum relative error between forecast and actual values (Azadeh et al. 2007). In this study, the first group of 37 data was used as the training set (about 75 per cent of the data), and the remaining 12 out of sample data (about 25 per cent of the data), was used for verifying and testing the robustness of the GA models.

To identify the best fitness, required parameters on the GA algorithm are as follows:

- Population size (n): 1000
- Iterations (the generation number): 200

- Mutation rate: 0.01

Prior to reviewing the modelling results, it is important to note that the GA modelling tested both the predictive capability of real GDP per capita and real GDP and Australia's population growth on Australia's domestic LCC air travel demand in separate models. The modelling results showed that the inclusion of both real GDP and Australia's population size provided more robust and accurate model forecasting capability; that is, the models utilising real GDP and population size gave superior forecasting accuracy over the use of real GDP per capita as the income measure. After applying the GAPAXDE and GARPXSDE model procedures, the equations for forecasting Australia's domestic LCC enplaned passengers (PAX) and revenue passenger kilometres (RPKs) were obtained based on the minimum sum of squares error between the observed and estimated data; these are (6.13) and (6.14) respectively.

The $GAPAXDE_{lin}$ and $GARPXSDE_{lin}$ present the linear models for forecasting Australia's domestic LCC enplaned passengers and revenue passenger kilometres (RPKs), respectively. The final linear $GAPAXDE_{lin}$ and $GARPXSDE_{lin}$ models comprise nine inputs.

$$GAPAXDE_{lin} = -5175.88 - 5.28X_1 + 0.0004X_2 + 0.03X_3 - 12.33X_4 - 720.25X_5 + 683.16X_6 + 0.01X_7 - 4724.51X_8 - 386.59X_9 \quad (6.13)$$

$$GARPXSDE_{lin} = -11979.27 - 3.85X_1 + 0.0005X_2 + 0.03X_3 - 12.75X_4 - 684.66X_5 + 660.25X_6 + 0.01X_7 - 4870.73X_8 - 427.88X_9 \quad (6.14)$$

Where: X_1 Australia's real best discount economy airfare, X_2 Australia's population size, X_3 Australia's real GDP, X_4 Australia's unemployment size, X_5 Australia's real interest rates, X_6 World jet fuel prices, X_7 recorded bed capacities at Australia's tourist accommodation establishments, X_8 dummy variable (Dummy 1) reflecting Virgin Australia changing business model, and X_9 dummy variable (Dummy 3) reflecting the Commonwealth Games held in Melbourne.

The GA selected the optimum variables for both the $GAPAXDE_{quad}$ and $GARPXSDE_{quad}$ quadratic models, and these are presented in the following equations.

$$\begin{aligned}
 GAPAXDE_{quad} = & 179379.96 - 1.08X_3 - 1555.37X_6 + 50385.57X_8 - 0.0001X_1X_3 + \\
 & 0.0000001X_2X_3 - 0.000002X_3^2 - 0.01X_4^2 - 5.59X_1X_5 + 24.17X_1X_6 - 0.0000001X_2X_7 + \\
 & 0.000001X_7^2 - 0.16X_3X_8 - 4.03X_4X_8 + 2066.28X_6X_8
 \end{aligned} \tag{6.15}$$

$$\begin{aligned}
 GARPksDE_{quad} = & -10056.81 + 2678.14X_6 - 2007.25X_8 - 0.01X_4^2 + 17.55X_1X_6 + \\
 & 0.001X_2X_6 + 0.01X_3X_6 + 4.14X_4X_6 + 73.85X_5X_6 - 0.03X_6X_7 + 0.0000001X_7^2 + 0.002X_2X_8 - \\
 & 0.14X_3X_8 - 0.001X_7X_9
 \end{aligned} \tag{6.16}$$

Following the training procedure, which produced the weighting factors (W_i) of the GA models, the testing procedure was performed

Using the 12 out of sample data set to verify and test the accuracy, reliability, and the robustness of the GA models. The absolute relative errors between the observed and estimated data for the two forms of GAPAXDE and GARPksDE models, linear and quadratic function forms are presented in Table 6.1 and Table 6.2, respectively. Table 6.1 compares the absolute relative error between the actual and forecasted values in the testing phase of the GAPAXDE linear and quadratic models. The obtained average relative error for the GAPAXDE linear and quadratic models is 8.13 per cent and 5.37 per cent, respectively.

Table 6.1. A comparison of the results of the linear and quadratic forms of GAPAXDE model with observed data for the testing period

Testing data	Actual PAX	Linear model	Relative Error (%)	Quadratic model	Relative Error (%)
1	2,505.12	2,503.21	0.08%	2,474.84	1.21%
2	2,213.16	2,410.97	8.94%	2,569.30	16.09%
3	2,528.78	2,503.43	1.00%	2,595.97	2.66%
4	3,640.47	3,538.14	2.81%	3,514.93	3.45%
5	4,885.53	5,048.16	3.33%	4,996.99	2.28%
6	5,747.42	6,460.70	12.41%	6,272.19	9.13%
7	6,659.99	7,133.36	7.11%	7,045.74	5.79%
8	7,345.82	7,546.38	2.73%	7,355.36	0.13%
9	3,464.50	3,134.83	9.52%	3,437.24	0.79%
10	3,697.94	4,306.30	16.45%	3,897.68	5.40%
11	6,253.02	4,908.13	21.51%	5,410.31	13.48%
12	5,855.81	5,172.74	11.66%	5,620.82	4.01%
MAPE (%)			8.13	5.37	

Similar to Table 6.1, Table 6.2 compares the absolute relative error between actual and forecast values in the testing phase of the GARPKSDE linear and quadratic models. The obtained mean absolute percentage error for the GARPKSDE linear and quadratic models is 9.35 per cent and 5.75 per cent, respectively.

Table6.2.A comparison of the results of the linear and quadratic forms of GARPKSDE model with the observed data for the testing period

Testing data	Actual RPKs	Linear model	Relative Error (%)	Quadratic model	Relative Error (%)
1	2,091.62	2,132.90	1.97%	1,875.63	10.33%
2	1,562.80	2,057.02	31.62%	1,731.80	10.81%
3	2,070.26	2,168.92	4.77%	2,027.19	2.08%
4	3,483.04	3,393.62	2.57%	3,201.18	8.09%
5	4,907.19	5,080.94	3.54%	5,166.49	5.28%
6	6,002.52	6,811.07	13.47%	6,682.51	11.33%
7	7,091.19	7,642.88	7.78%	7,417.85	4.61%
8	7,657.86	8,032.51	4.89%	7,960.77	3.96%
9	4,156.10	3,576.08	13.96%	4,183.79	0.67%
10	4,105.10	4,756.20	15.86%	4,296.18	4.65%
11	5,996.95	5,398.85	9.97%	5,723.87	4.55%
12	5,574.36	5,675.76	1.82%	5,718.51	2.59%
MAPE (%)			9.35	5.75	

Table 6.3 presents the mean absolute error (MAE), mean absolute percentage error (MAPE), mean square error (MSE), and root mean square error (RMSE) in training, out of sample testing, and overall data set of the GAPAXDE linear and quadratic models for forecasting Australia's domestic LCC enplaned passengers. These results show that, the GAPAXDE quadratic models performed better than the linear models during both training and testing phase as measured by MAE, MAPE, MSE and RMSE. In the testing phase where out of sample data set was used to forecast Australia's domestic LCC enplaned passenger demand, the MAPE value of the GAPAXDE linear and quadratic models was 8.13 per cent and 5.37 per cent respectively.

Table 6.3. Performance index of GAPAXDE linear and quadratic models for training, testing (out of sample), and overall data set

Performance index	GAPAXDE linear model			GAPAXDE quadratic model		
	Train	Test	Overall	Train	Test	Overall
MAE	201.33	403.60	250.87	139.42	242.95	164.77
MAPE	3.88%	8.13%	4.92%	2.76%	5.37%	3.40%
MSE	6.2×10^4	3.0×10^5	1.2×10^5	3.1×10^4	1.2×10^5	5.1×10^4
RMSE	248.64	548.02	346.74	175.12	340.43	227.02

Table 6.4 presents the mean absolute error (MAE), mean absolute percentage error (MAPE), mean square error (MSE), and root mean square error (RMSE) in training, out of sample testing, and overall data set of the GARPXSDE linear and quadratic models for forecasting Australia's domestic LCC revenue passenger kilometres (RPKs). The GARPXSDE quadratic models performed better than the linear models during both training and testing phases. In the testing phase, the MAPE value of the GARPXSDE linear and quadratic models 9.35 per cent and 5.75 per cent respectively.

Table 6.4. Performance index of GARPXSDE linear and quadratic models for training, testing (out of sample), and overall data set

Performance index	GARPXSDE linear model			GARPXSDE quadratic model		
	Train	Test	Overall	Train	Test	Overall
MAE	218.32	436.52	258.40	159.01	276.30	180.55
MAPE	4.64%	9.35%	5.30%	3.37%	5.75%	3.68%
MSE	7.5×10^4	2.5×10^5	1.1×10^5	4.3×10^4	1.0×10^5	5.5×10^4
RMSE	274.78	501.67	328.42	208.38	323.21	233.74

This study further employed a hypothesis test to give an indication if the difference between the models utilised was in fact statistically significant. Since the same 12 data testing set were used for forecasting in all models, the paired *t*-test was used to assess the forecasting accuracy of the respective models and also to test the hypothesis (H_0) that there is not a significant difference in the forecasting accuracy of the GA linear and quadratic models (Razi and Athappily, 2005; Zaefizadeh et al. 2011). That is,

- $H_0: \mu_{linear} \leq \mu_{quadratic}$
- $H_1: \mu_{linear} > \mu_{quadratic}$

The results of t-tests are presented in Table 6.5.

Table 6.5. Results of paired t-test

Test	<i>t-stat</i>	<i>P-value</i>	Conclusion
GAPAXDE H_{01} : linear vs quadratic	2.58	.01	$\mu_{linear} > \mu_{quadratic}$
GARPKSDE H_{02} : linear vs quadratic	1.95	.04	$\mu_{linear} > \mu_{quadratic}$

Where μ_{linear} and $\mu_{quadratic}$ are mean forecasting error of GA linear and quadratic models, respectively

Table 6.5 shows that the *p-values* (one-tail) for H_{01} is .01 and H_{02} is .04, therefore H_{01} and H_{02} are rejected. This implies that the average forecasting error of the GA linear models are statistically significantly different from the average forecasting error of GA quadratic models (both GAPAXDE and GARPKSDE) at the 95 per cent confidence interval of the difference. The results also indicated that the forecasting error of GA linear models are higher than the GA quadratic models. These results also confirm that the GA quadratic models are superior to the linear models when used to forecast Australia's domestic airline enplaned passengers (PAX) and revenue passenger kilometres (RPKs), respectively.

Australia's actual domestic LCC and forecast enplaned passengers, during the period from Quarter 1 2002 to Quarter 1 2014, are plotted and shown in Figure 6.2.

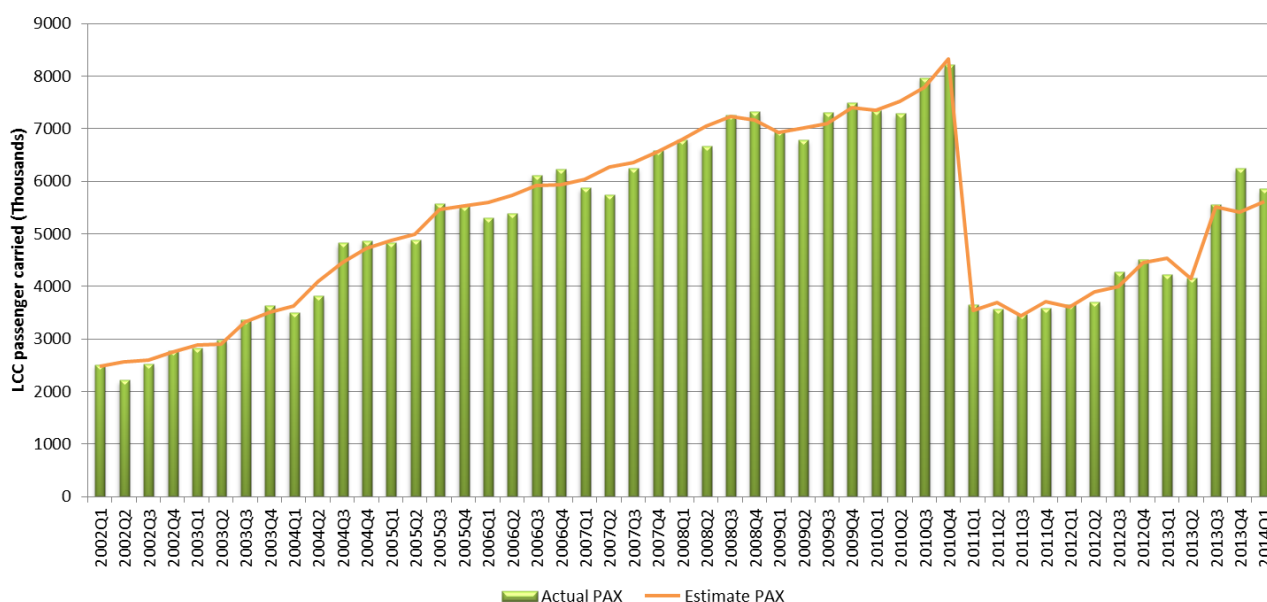


Figure 6.2. A comparison of Australia's domestic LCC actual and forecast enplaned passengers (GAPAXDE Model).

Finally, Australia's actual domestic LCC and forecast revenue passenger kilometres (RPKs), during the period from Quarter 1 2002 to Quarter 1 2014, are plotted and shown in Figure 6.3.

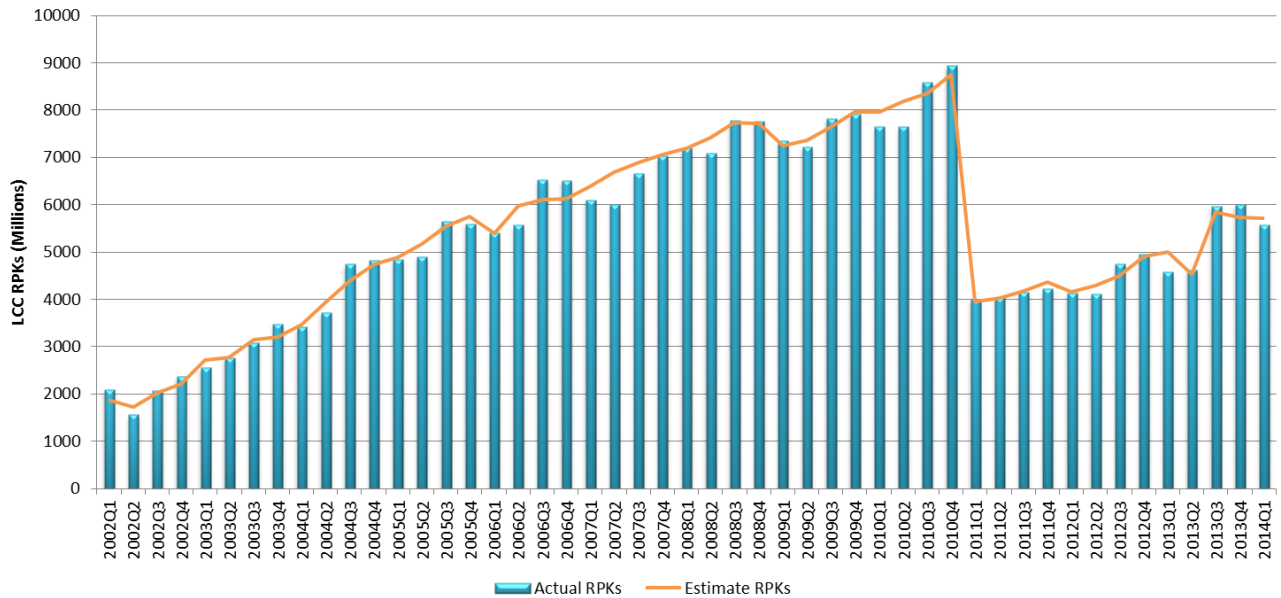


Figure 6.3. A comparison of Australia's domestic LCC actual and forecast RPKs (GARPKSDE Model)

6.6 Summary

This chapter has developed and empirically examined two genetic algorithm models for forecasting Australia's domestic LCC demand (GAPAXDE and GARPKSDE models). Two mathematical forms, linear, and quadratic were tested.

Data was divided into training and testing data sets, training data set of 37 is used to estimate the weighting factors (W_i) of the GA models and the out of sample data set of 12 was used to test the robustness of the GA models. The genetic algorithm parameters which provided the best model fitness comprised population size (n): 1000, the generation number: 200, and Mutation rate: 0.01. Modelling results showed both the quadratic GAPAXDE and GARPKS models to be more accurate, reliable and have greater predictive capability in comparison to the linear models. The MAPE of GAPAXDE_{quad} and GARPKSDE_{quad} models in testing phase are 5.37% and 5.75%, respectively.

The following chapter presents the last modelling approach and empirically examines a new adaptive neuro-fuzzy inference network model (ANFIS) approach for forecasting Australia's domestic LCC passenger demand. Chapter 8 presents the study's empirical findings.

CHAPTER SEVEN: AN ADAPTIVE NEURO-FUZZY INFERENCE SYSTEM FOR FORECASTING AUSTRALIA'S DOMESTIC LOW COST CARRIER PASSENGER DEMAND

7.1 Introduction

The three previous chapters have proposed multiple linear regression, artificial neural network (ANN), and genetic algorithm (GA) models which can be used for forecasting Australia's domestic LCC passenger demand. This chapter presents the final modelling approach using the adaptive neuro-fuzzy inference system (ANFIS) technique. As noted in Chapter 1, ANFIS models are increasingly being used for forecasting purposes in a wide range of disciplines. Despite their growing popularity and greater accuracy and reliability together with their greater predictive capabilities, there has been no reported study which proposed and empirically examined such an approach in the airline industry. This chapter therefore aims to address this apparent gap in the literature.

The chapter is structured as follows: Section 7.2 presents the adaptive neuro-fuzzy inference system (ANFIS) architecture. ANFIS models for forecasting Australia's domestic LCC passenger demand is presented in Section 7.3. The proposed ANFIS model setup is presented in Section 7.4. This is followed by an overview of the ANFIS data training (Section 7.5) and goodness of fit measures used in the ANFIS modelling process in Section 7.6. The ANFIS modelling results are presented in Section 7.7.

7.2 Adaptive Neuro-Fuzzy Inference System (ANFIS) Architecture

Adaptive neuro-fuzzy inference system (ANFIS) is an adaptive network made up of several nodes and directional links through which learning rules are connected (Kablan 2009). According to Kablan (2009, p.450) "It is ... adaptive because some, or all, of the nodes have parameters which influence the output of the node". Yetilmezsoy et al. (2011, p.53) noted that the ANFIS process resembles "the feed forward back propagated (FFBP) artificial neural network in which consequent parameters are calculated forward, while premise parameters

are calculated backward” (Yetilmezsoy et al. 2011, p.53). ANFIS consists of “antecedent and conclusion parameters” which are connected together by a fuzzy rules set (Yetilmezsoy et al. 2011, p.53). Arkhipov et al. (2008, p. 496) noted the development of “two types of fuzzy inference systems: *Mamdani-type* and *Sugeno-type*”. The principal difference between the two systems (FIS³¹) is output determination’s method. While the Mamdani FIS produces linear membership functions (MFs) output, the Sugeno FIS produces either constant or linear ones (Arkhipov et al. 2008, p. 496).

This study used the *Sugeno-type* FIS system. According to Yetilmezsoy et al. (2011, p.53), generally, two learning algorithm types are available in the ANFIS’s neural network system unit which are “hybrid learning algorithms and back propagation (BP) learning algorithms” (Yetilmezsoy et al. 2011, p.53). To determine the output variables of ANFIS, fuzzy rule sets of input variables are executed (Cakmakci et al. 2010; Jang 1993; Takagi & Sugeno 1985). A typical ANFIS employs a Takagi-Sugeno model-based fuzzy inference approach to form the related hybrid system (Köse & Arslan 2013). The ANFIS architecture is illustrated by use of two fuzzy If-then rules of a first order Sugeno FIS (Bagheri et al. 2014; Übeyli et al. 2010).

Rule1: if x is A₁ and y is B₁ then f₁ = p₁x + q₁y + r₁

Rule2: if x is A₂ and y is B₂ then f₂ = p₂x + q₂y + r₂

where x and y represent input variables of FIS, A_i and B_i denote the fuzzy sets, f_i denote the output within a fuzzy rule, and p_i , q_i , and r_i the design parameters which are estimated in the training phase (Übeyli et al. 2010).

³¹ According to Laplante (2005, p.287), “*Fuzzy inference systems* (FIS) are a computing framework based on fuzzy set theory, fuzzy IF-THEN rules, and approximate reasoning”

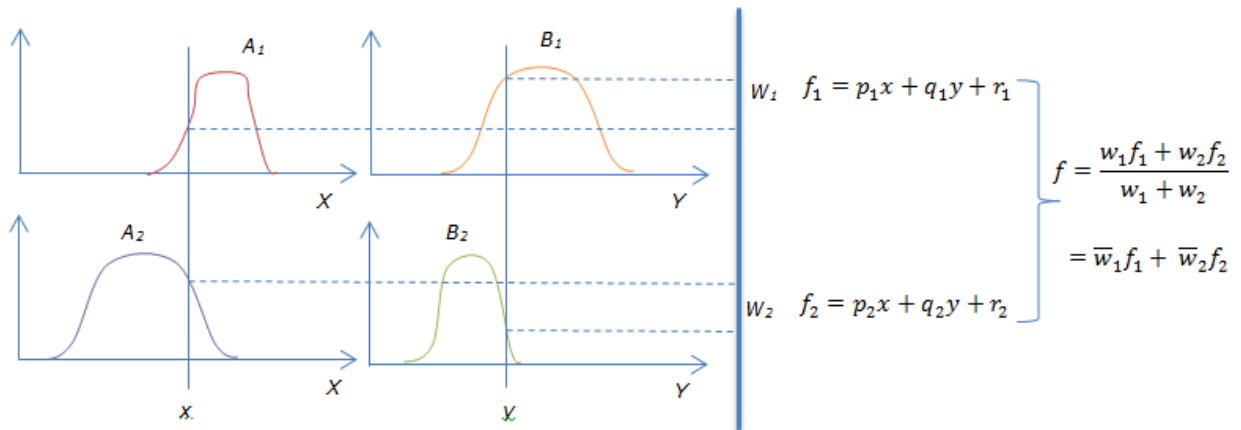


Figure 7.1. Fuzzy reasoning mechanism
Source: adapted from Efendigil et al. (2009, p.6701).

The architecture of ANFIS as applied the two fuzzy If-then rules above is depicted in Figure 7.2. The ANFIS architecture comprises 5 layers that is, “a fuzzy layer, a product layer, a normalised layer, a defuzzy layer and a total output layer” (Yetilmezsoy et al. 2011, p.53). ANFIS’ nodes are defined by two types of node parameter including fixed or adaptive parameters, as indicated in Figure 7.2, a circle symbol is used for a fixed node, while a square symbol is used for an adaptive node (Ch & Mathur 2010). To obtain the ANFIS parameter values, the learning or training process in neural network section is performed. Model accuracy in training and testing phases is measured by an error performance index such as root mean square error (RMSE) which is minimised by selected learning algorithms, either hybrid or back propagation (BP). (Yetilmezsoy et al. 2011).

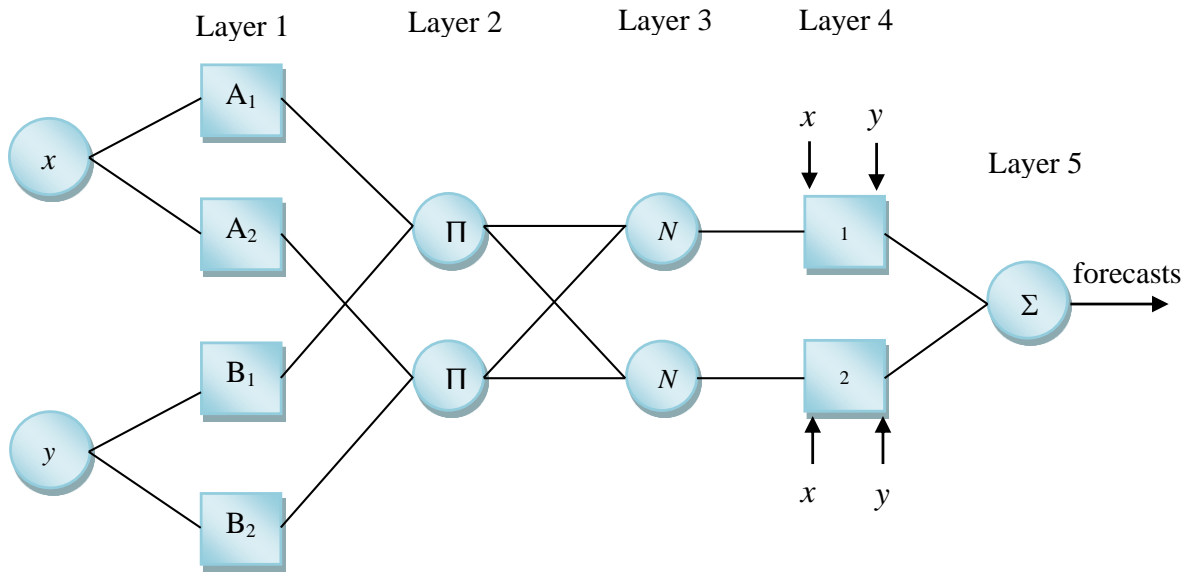


Figure 7.2. Architecture of the ANFIS model with two inputs and two rules

Each layer of ANFIS has its own task, and the following section describes the relationship between output and input layer in the ANFIS.

Layer 1 is the fuzzification layer that passes crisp external signals to the following layer directly (Xiao et al. 2014). In the fuzzy layer, x and y are the input of nodes A_1 , A_2 , B_1 , and B_2 , respectively. A_1 , A_2 , B_1 , and B_2 are the linguistic labels used in fuzzy theory for dividing membership functions (Yetilmezsoy et al. 2011). It is noted that each node i in layer 1 is an “adaptive node”, identified by a “specific function” (Übeyli et al. 2010; Yetilmezsoy et al. 2011). In layer 1, fuzzy membership functions are implemented by nodes as well as input variables which are mapped to the values of associated fuzzy memberships (Yetilmezsoy et al. 2011). In this layer, the parameters identified as “*premise parameters*” (Yilmaz & Kaynar 2011). The output of layer 1 indicates the degree/grade of fuzzy membership function of given inputs which are determined by the fuzzy membership function (Xiao et al. 2014). The output of layer 1 is:

$$O_i^1 = \mu_{A_i}(x), i = 1,2 \text{ or } O_i^1 = \mu_{B_{i-2}}(y), i = 3,4 \quad (7.1)$$

where x and y are the input to the i th node and A_i and B_{i-2} are linguistic labels associated with this node (Xiao et al. 2014).

Thus, O_i^1 is a fuzzy set A ($=A_1, A_2, B_1, \text{ or } B_2$) membership grade identifying the degree to which the quantifier A is satisfied by the given input x/y , where any fuzzy membership function types can be adopted by $\mu A_i(x)$ and $\mu B_{i-2}(y)$ (Übeyli et al. 2010). For example, if the bell shaped membership function is used it is given by (Übeyli et al. 2010).

$$\mu A_i(x) = \frac{1}{1 + \left[\left(\frac{x-c_i}{a_i} \right)^2 \right]^{b_i}} \quad (7.2)$$

where $\{a_i, b_i, c_i\}$ are parameters of the function (Xiao et al. 2014). The back propagation algorithms obtain their values, during the learning stage. When these parameters value change, the bell-shape function will also change, thus various forms of membership functions are demonstrated on linguistic label A_i (Xiao et al. 2014; Yetilmezsoy et al. 2011).

Layer 2 is a rule layer, each node is a representation of a rule and the inputs are the degrees of membership functions which are multiplied through a T-norm operator so as to determine the level of fulfilment of w_i the rule (Ch & Mathur 2010). The nodes are fixed nodes and are labelled “ \prod ”, which indicates they perform as a single multiplier (Übeyli et al. 2010). Each node represents the firing strength of the reasoning rule (Patil et al. 2011; Yilmaz & Kaynar 2011). The outputs of this layer can be represented as:

$$O_i^2 = w_i = \mu A_i(x) \times \mu B_i(y), i = 1,2 \quad (7.3)$$

Layer 3 is the normalization layer, whose nodes are labelled “N”, which mean they play a normalization role for firing strengths from the previous layer (Übeyli et al. 2010; Yetilmezsoy et al. 2011). This layer normalizes each rule’s output with respect to the rest of the rule set, and normalization scales the rule’s output to a value between zero and one by dividing its output by the number of inputs (Schott & Kalita 2011).

$$O_i^3 = \bar{w}_i = \frac{w_i}{w_1+w_2}, i = 1,2 \quad (7.4)$$

Where “ w_i is the firing strength of the i th rule ... computed in layer 2 Node i computes the ratio of the i th rule’s firing strength to the sum of all rules’ firing strengths” (Xiao et al. 2014, p.4).

Layer 4 is the defuzzification layer in which the nodes are adaptive nodes (Übeyli *et al.* 2010; Yetilmezsoy *et al.* 2011). A linear function is computed by every node in the defuzzification layer where the error function of the multi-layer feed forward neural network is used to adapt the function coefficients (Xiao *et al.* 2014). Yilmaz & Kaynar (2011, p.5964), explain that “the parameters in this layer are called *consequent parameters*”

$$O_i^4 = \bar{w}_i f_i = \bar{w}_i (p_1 x + q_1 y + r_1), i = 1, 2 \quad (7.5)$$

(p_1, q_1, r_1) is the parameter set.

The fifth ANFIS layer, whose node is labelled “ Σ ”, is the output layer, in which a single node calculates the overall output as a summation of all incoming signals (Ch & Mathur 2010; Giovanis 2012; Xiao *et al.* 2014). Hence, the overall output of the model can be written as (Fang 2012; Yetilmezsoy *et al.* 2011):

$$O_i^5 = \sum_i \bar{w}_i f_i = \frac{\sum_i w_i f_i}{\sum_i w_i} \quad (7.6)$$

where $\bar{w}_i f_i$ denotes the consequent part of rule i . The overall output of the neuro-fuzzy system is the summation of the rule consequences (Xiao *et al.* 2014).

As previously noted, in the ANFIS structure, the premise and consequent parameters are important factors for the learning algorithm in which each parameter is used to calculate the output data of the training data (Efendigil *et al.* 2009). The premise part of a rule defines a subspace, whereas the consequent part specifies the output within this fuzzy subspace (Jang 1993).

ANFIS allows for the use of two learning algorithms, back propagation and hybrid methods, which seek to minimize the error measures, such as, MSE or RMSE between observed and forecast data (Yetilmezsoy *et al.* 2011). There are two methods in the hybrid learning rule providing optimal parameters which are “the gradient method and least squares method” (Jang 1993, p. 671). Further, it can be observed that when premise parameters’ values of the hybrid learning algorithm are fixed, consequent parameters are formed as a linear function expressing overall output (Yetilmezsoy *et al.* 2011).

Although both neural network and fuzzy logic models are classified as artificial intelligence based (Yetilmezsoy et al. 2011), the ANFIS combines both of these, capturing the advantages of both (Ch & Mathur 2010; Liu et al. 2008; Tiwari et al. 2012). As the ANFIS is a hybrid adaptive system which permits use of neural network topology with a fuzzy inference system, the advantages of both models are included while the disadvantages of the two models, used individually, are avoided (Yetilmezsoy et al. 2011). Accordingly, ANFIS is able to deal with complex and non-linear problems (Giovanis 2012). Yetilmezsoy et al. (2011, p.54) observed that “even if the targets are not given, ANFIS may reach the optimum result very quickly”. Further, Tiwari et al (2012) noted that unlike the ANN, no vagueness is detected in the ANFIS. It is also argued that the ANFIS can attain the target more rapidly than can ANNs (Kumar et al. 2011). Hence, when dealing with a complex and high-dimensional system, utilizing ANFIS is more practical to handle complex problem than using ANN (Noori et al. 2009).

Noori et al. (2009) noted that errors implications in the ANFIS structure differ from those of neural networks. Further, to ascertain the optimal output, the epoch range is unlimited (Noori et al. 2009). Therefore in dealing with complex and high-dimensional data, the ANFIS is capable to provide better results than the ANN and other fuzzy-logic models based on the error measurement value such as RMSE (Chi et al. 2005; Yetilmezsoy et al. 2011).

In the ANFIS system, each input parameter may be clustered into several class values in layer 1 to build up fuzzy rules. Each fuzzy rule would be set using two or more membership functions in layer 2. Several methods have been proposed to classify the input data and for the rule-making, among which the most common being grid partition (Jang et al. 1997) and subtractive fuzzy clustering (Chiu 1994). When there are a few input variables, grid partition is considered a suitable method for data classification. However, in this study because of many input variables and the requirement for considerable membership functions, the subtractive clustering method was utilized. For example, if we have 11 input variables and each input has variable 3 membership functions, the rules will be 3^{11} rules (177,147 rules) and the calculation of the parameters of this model will therefore be very complex (Noori et al. 2009). Therefore, in this study subtractive fuzzy clustering was used to establish the rule-based relationship between input and output variables.

According to Yetilmezsoy et al. (2011, p.54), “the subtractive clustering method” is the method used to classify observations into clusters. Each observation is assumed to be a potential cluster centre and the likelihood measure of each observation is calculated in order

to define the cluster centre based on the concentration of adjacent observations (Yetilmezsoy et al. 2011). The highest potential observation is selected to be the first cluster centre by the algorithm. All observations surrounding the area of the first cluster centre are then removed in order to define the next data cluster and the next cluster centre is located. The process is iterated until all observations are located in a cluster centre radii (Yetilmezsoy et al. 2011). The subtractive clustering method comprises four algorithm parameters including “range of influence (ROI), squash factor (SF), accepted ratio (AR) and rejected ratio (RR)” (Cakmakci et al. 2010; Yager & Filev 1994).

Subtractive clustering was developed by Chiu (1994) in order to estimate both the number and initial locations of cluster centres. Consider a set T of N data points in a D -dimensional hyper-space, where each data point W_i ($i = 1, 2, \dots, N$) $W_i = (x_i, y_i)$ where x_i denotes the p input variables and y_i is the output variable. The potential value P_i of data point is calculated by Equation (7.7):

$$P_i = \sum_{j=1}^N e^{-\alpha \|W_i - W_j\|^2} \quad (7.7)$$

where $\alpha = 4/r^2$, r is the radius defining a W_i neighbourhood, and $\|\cdot\|$ denotes the Euclidean distance (Wei et al. 2011).

The data point with many neighbouring data points is chosen as the first cluster centre. To generate the other cluster centres, the potential P_i is revised of each data points W_i by Equation (7.8):

$$P_i = P_i - P_k^* \exp(-\beta \|W_i - W_k^*\|^2) \quad (7.8)$$

where $W_k^* = (x_k^*, y_k^*)$ is the location of the k th cluster centre and P_k^* is its potential value.

At the end of the clustering process, the method obtains q cluster centres and D corresponding spreads S_i , $i = (1, \dots, D)$. Then we define their membership functions. The spread is calculated according to β (Wei et al. 2011).

7.3. ANFIS Models for Forecasting Australia's Domestic LCC Passenger Demand

7.3.1. ANFIS process

As Figure 7.3 shows the study was undertaken in three discrete phases. In the first phase an extensive literature review was undertaken to identify the extant knowledge on the predictors of domestic LCC passenger demand. The requisite data was then sourced for the candidate input and output variables. This data was subsequently normalized following the recommendations of Ghassemzadeh et al. (2013) and Mittal et al. (2012). The following step involved the data input. The input of the data included the input data and output data in the form of data array (Chen et al. 2010, p. 1187). The final action at this stage involved defining and partitioning the universe of discourse for the input variables using the subtractive clustering method (Cakmakci 2007; Wei et al. 2011).

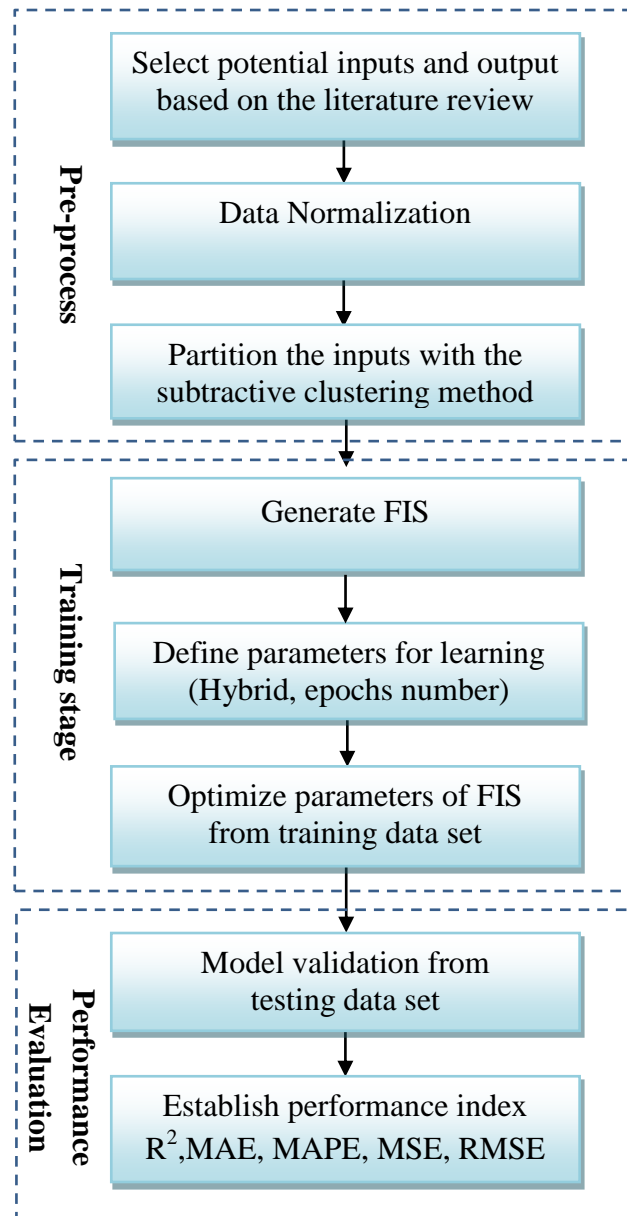


Figure7.3.The ANFIS process for forecasting Australia's domestic LCC passenger demand

The next step involved generating the fuzzy inference system (FIS) (Chen et al. 2010; Efendigil et al. 2009). The initialization of the fuzzy system was performed using the *genfis 2* command, which specifies the structure and initial parameters of the FIS with the training data matrix, number of membership functions (MFs), and membership types associated with each input (Patil et al. 2011). Generally, the coefficients for the MFs are initially selected by trial and error, and subsequently, fine-tuned using the hybrid learning algorithm (Gao & Ovaska 2002).

The FIS parameters from the training datasets were then optimised, using the least square method and the backpropagation gradient descent method for training the forecasting ANFIS models (Wei et al. 2011; Yetilmezsoy et al. 2011). The training of the study's data was performed automatically in the ANFIS system and an array of training errors was obtained (Chen et al. 2010, p. 1187). Following training, an ANFIS model with forecasting function was obtained for output forecasting (Bagheri et al. 2014; Chen et al. 2010, p. 1187). The models computed the overall output as a summation of all incoming signals (Efendigil et al. 2009). Finally, a performance index, based on R^2 , MAE, MAPE, MSE and RMSE (see Section 7.6 below), was established to evaluate performance of the models.

7.3.2. Data normalization

In the ANFIS modelling, each input/output pair contained 11 inputs (that is, Australia's real GDP, Australia's real GDP per capita, Australia's real best discount air fares, Australia's population size, Australia's unemployment size, Australia's tourist accommodation establishments recorded bed spaces, world jet fuel prices, Australia's real interest rates and 3 dummy variables (the same dummy variables included in the MLR, ANN and GA modelling) and 1 output (PAX or RPKs, respectively). The output data are Australia's domestic LCC' enplaned passengers and RPKs (Section 4.3 presents the data sources).

Prior to training data in the ANFIS, it is essential to transform all input into patterns. Training and testing vectors are also formed into patterns. Baseri (2011 p. 760) noted that "each pattern is formed with an input condition vector as well as the corresponding target vector". Input and output data scaling is also an essential issue for consideration, particularly when process parameters' operating ranges are diverse (Baseri 2011). Data normalization of data determines that the system will be trained efficiently, and ensures that results are not skewed by particular variables (Baseri 2011).

All data were therefore normalized prior to use in the training phase using Equation (7.9). Data normalization was applied to transform the data to a symmetric distribution which improves model performance since the data appear to more closely satisfy the assumptions of a statistical inference procedure also following the transformations of variables (Ghassemzadeh et al. 2013). Data is normalized using the following equation:

$$x_{norm} = \frac{x - x_{min}}{x_{max} - x_{min}} \quad (7.9)$$

where x_{norm} is the normalized value, x is the actual value, x_{max} is the maximum value, and x_{min} is the minimum value (Kalkhaheh et al. 2012).

There are several advantages of normalizing data prior to processing in ANFIS for prediction. One advantage being that the avoidance of attributes in greater numeric ranges dominating those of smaller data ranges. The second advantage is the avoidance of numerical difficulties experienced during the calculation (Mittal et al. 2012). With data normalization, the data are scaled so they fall within a pre-specified range, such as [0, 1] (Mitsa 2010). In this study's modelling process, all data values were scaled in the range between 0 and 1 using Equation (7.9). A further advantage of normalizing the data is that normalization also removes any arbitrary effects of similarity between objects whilst also increasing the answer rate data to the input signal (Mittal et al. 2012).

7.4 ANFIS Models Setup

This study utilized “the Fuzzy Logic Toolbox 2.2.16, the ANFIS (Adaptive Neuro-Fuzzy Inference System) Editor GUI graphical user interface” within the framework of MATLAB R2012b (8.0.0.783) (The MathWorks, Inc., USA.) software for modelling and simulation purposes.

The *Sugeno ANFIS network setup* process is conducted with 25 membership functions and membership function type is Gaussian. The architecture of the study's ANFIS is depicted in Figure 7.4. The ANFIS models used the hybrid learning algorithm.

The neuro-fuzzy models were run for each combination of model parameter with varying numbers of epochs and types of input-output membership functions (MFs). This was to avoid the possible over-fitting of the models. In this study, the models were constructed using 25 rules (Efendigil et al. 2009). Also, different types of membership functions (MFs) were tested (Baseri 2011; Yan et al. 2010) such as triangular-shaped built-in MF (triMF), generalized bell shape built-in MF (gbellMF) and Gaussian curve built-in MF (gaussMF) (Baseri 2011; Yan et al. 2010). The Gaussian-curve function and 25 rules is the best architecture for the two ANFIS models. The generated membership functions are able to display the interactions and relationships between the various ANFIS levels. Figure 7.5 A. and Figure 7.5 B. shows the

fine curves of the trained models of both ANFIS PAX and RPKs model with smooth curve interaction for each parameter suggesting the best fit of the developed models (Mittal et al. 2012).

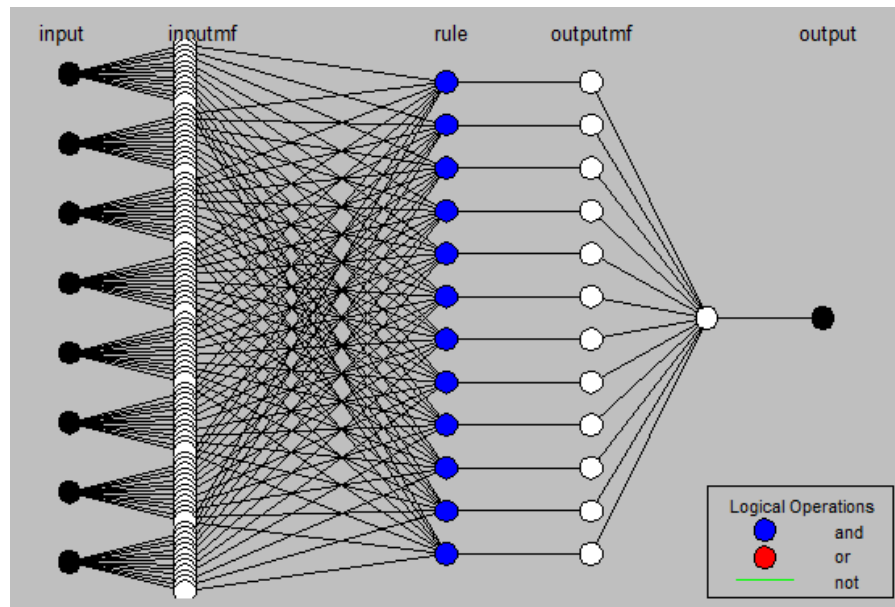


Figure 7.4. The optimum ANFIS model architecture for forecasting Australia's domestic LCC enplaned passengers (PAX) and RPKs.

In this study, the ANFIS model was structured for forecasting Australia's domestic LCC passenger demand using *Sugeno* FIS approach with 8 inputs and 1 output. The "product" function is used for linking the rules together, "weighted average" is used for rule defuzzification and the subtractive clustering algorithm partition method is applied to generate optimum 12 fuzzy rule base sets (Efendigil et al. 2009) where membership functions shape in input layer is set as Gaussian membership function and the shape of linear membership function is used in output layer. Two examples of the ANFIS PAX and RPKs model's 12 rules are as follows:

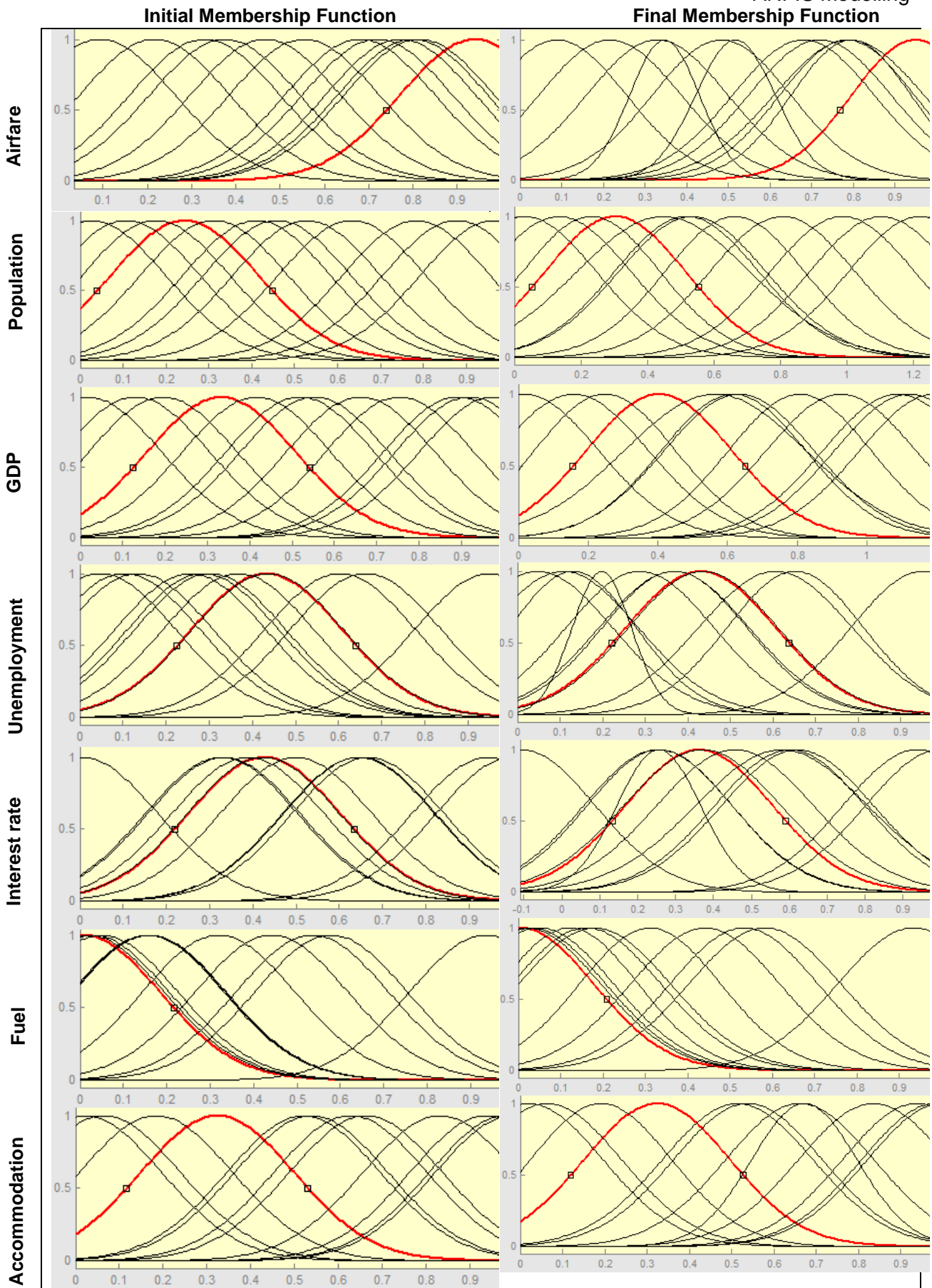


Figure 7.5A. Initial and final Gaussian membership functions for the ANFIS PAX models.

Initial Membership Function

Final Membership Function

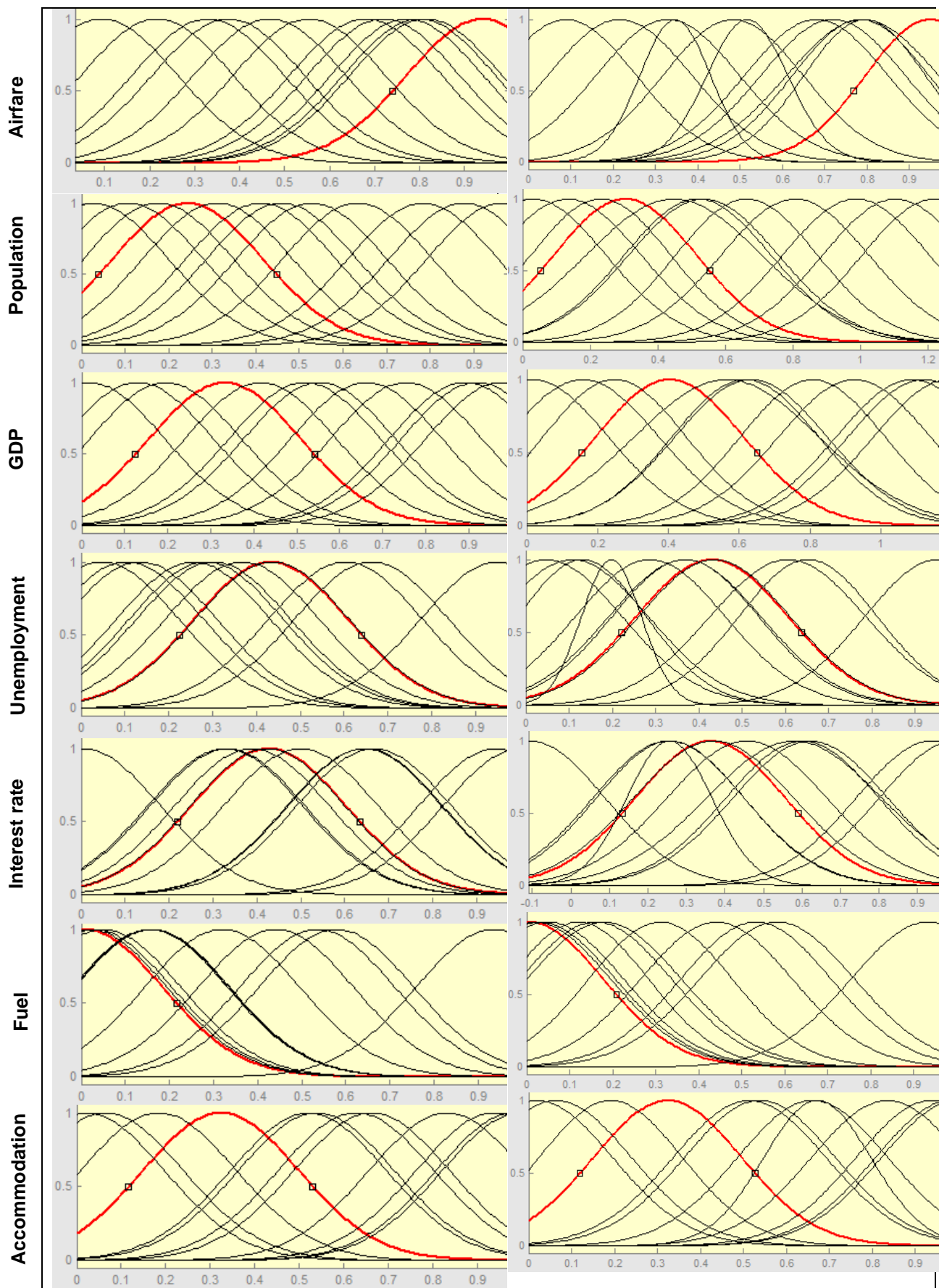


Figure 7.5B. Initial and final Gaussian membership functions for the ANFIS RPKs models.

Rule1: If (Fare is in1cluster1) and (pop is in2cluster1) and (gdp is in3cluster1) and (unemp is in4cluster1) and (INT is in5cluster1) and (fuel is in6cluster1) and (Accom is in7cluster1) and (D1 is in8cluster1) then (PAX is out1cluster1)

Rule 12: If (Fare is in1cluster12) and (pop is in2cluster12) and (gdp is in3cluster12) and (unemp is in4cluster12) and (INT is in5cluster12) and (fuel is in6cluster12) and (Accom is in7cluster12) and (D1 is in8cluster12) then (PAX is out1cluster12)

7.5 ANFIS Models Data Training

Training is a key part of the ANFIS model development process. The training process is used to optimize the model, and subsequent testing is to check the performance and consequently the generalization ability of the developed model (Mehta & Jain 2009). In this study, the testing data subset was independent from the training dataset. While the training dataset was used for a training purpose in modelling the ANFIS, the testing dataset was used to validate ANFIS model's accuracy and efficiency (Azadeh et al. 2010; Galavi & Shui 2012; Übeyli et al. 2010). The data was therefore randomly divided into two datasets: training and testing. The training dataset consists of 36 observations which were used in the training phase (85 per cent of the overall dataset) and 6 observations which did not participate in the training phase were used to validate and test the ANFIS forecasting model's accuracy and robustness (Yetilmezsoy et al. 2011).

The task of the learning algorithm for the study's ANFIS architecture is to tune all modifiable parameters, that is, (a_i, b_i, c_i) and (p_i, q_i, r_i) , to ensure that the ANFIS output matches the training data. When the premise parameters a_i, b_i, c_i of the membership function are fixed, the output of the ANFIS can be expressed as (Übeyli *et al.* 2010):

$$f = \frac{w_1}{w_1+w_2} f_1 + \frac{w_2}{w_1+w_2} f_2 \quad (7.10)$$

Substituting Equation (7.4) into Equation (7.10) yields:

$$f = \bar{w}_1 f_1 + \bar{w}_2 f_2 \quad (7.11)$$

Further substituting the fuzzy If-then rules into Equation (7.11), it becomes:

$$f = \bar{w}_1(p_1x + q_1y + r_1) + \bar{w}_2(p_2x + q_2y + r_2) \quad (7.12)$$

Following, rearrangement, the output can be expressed as:

$$f = (\bar{w}_1x)p_1 + (\bar{w}_1y)q_1 + (\bar{w}_1)r_1 + (\bar{w}_2x)p_2 + (\bar{w}_2y)q_2 + (\bar{w}_2)r_2 \quad (7.13)$$

which is a linear combination of the modifiable consequent parameters p_1, q_1, p_2, q_2, r_1 and r_2) (Übeyli et al. 2010, p. 682).

To estimate the parameters' optimal values, "the least squares estimation" (LSE) method can be utilised quite easily (Übeyli et al. 2010). In the ANFIS learning process, "a gradient based method" is normally used. Nevertheless, it is argued that this method performs very slowly and may be trapped in a local minimum (Kablan 2009). This study used a standard hybrid learning algorithm as proposed by Jang (1993), which utilises a combination of steepest gradient and LSE (Übeyli et al. 2010). Each epoch of this hybrid learning procedure comprises forward pass and back propagation (Chen et al. 2010).

In the forward pass, functional signals proceed forward to till layer 4 and the resulting parameters are identified by the LSE (Kablan 2009; Yan et al. 2010). Once optimum consequent parameters are obtained, the backward pass commences at once (Efendigil et al 2009; Übeyli et al. 2010). In the backward pass, the error rates propagate backward and the premise parameters are updated by gradient descent (Yan et al. 2010; Yilmaz & Kaynar 2011). The ANFIS output is estimated by utilizing consequent parameters located in the forward pass. In turn the output error is used to adapt premise parameters by back-propagation algorithm's standard mean (Übeyli et al. 2010). It has been demonstrated that this hybrid algorithm is highly efficient in ANFIS training (Jang 1993, Kablan 2009; Übeyli et al. 2010). Table 7.1 presents a summary of activities in both forward and backward passes.

Table 7.1. Summary of the activities in forward and backward passes for ANFIS

	Forward Pass	Backward Pass
Premise Parameters	Fixed	Gradient Descent
Consequent Parameters	Least Squares Estimate	Fixed
Signals	Node outputs	Error Rates

Source: Jang (1993)

Each ANFIS model used 37 training data in 1-400 training epochs (Übeyli et al. 2010). Figure 7.6 shows the training curve of ANFIS (PAX Model) with root mean square error

(RMSE) of 5.55×10^{-6} . Figure 7.7 shows the training curve of ANFIS RPKs model with an RMSE of 5.34×10^{-6} . These figures display the level of modelling accuracy in terms of error achieved (Mittal et al. 2012).

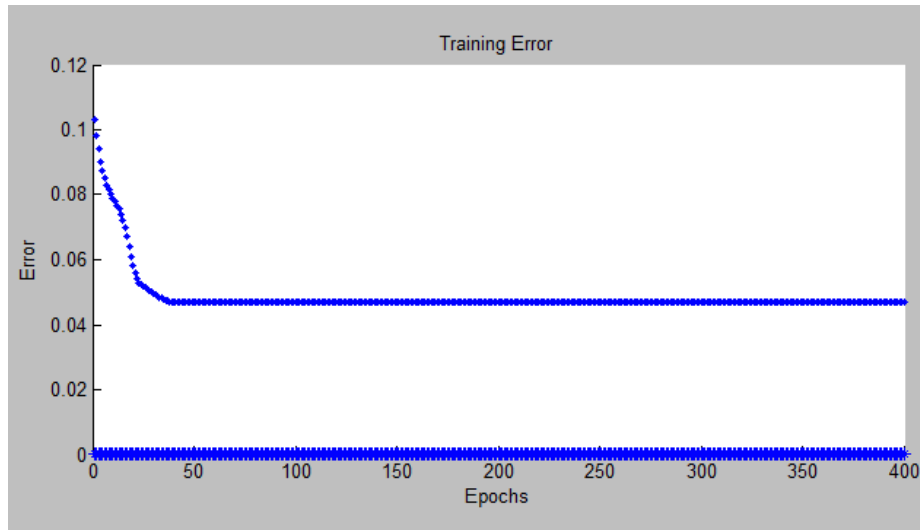


Figure7.6.Error change during training of the ANFIS PAX model

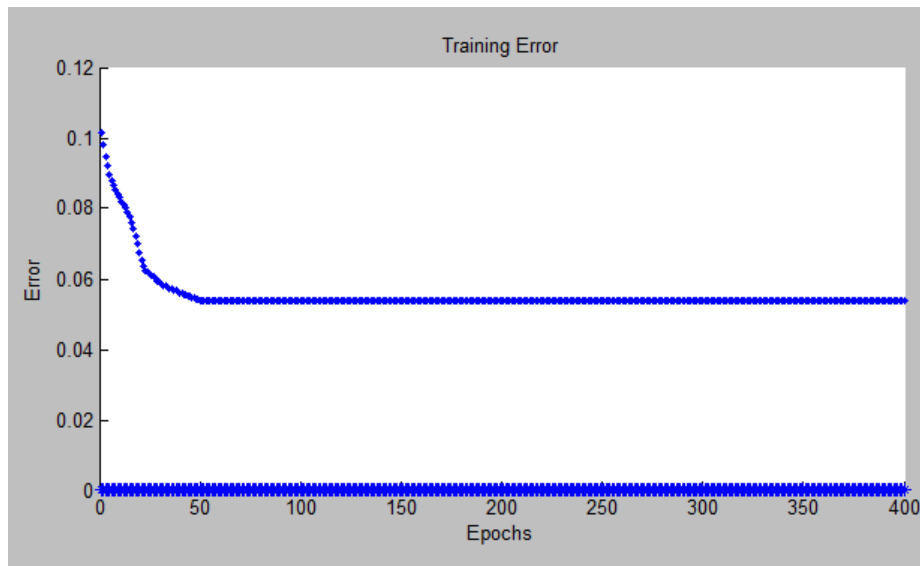


Figure7.7.Error change during training of the ANFIS RPKs model

A comparison between the actual and ANFIS forecast PAX and RPKs models values following the completion of training are presented in Figures 7.8 and 7.9, respectively. These

two figures show the ANFIS system is well-trained to model Australia's actual domestic LCC passenger demand, as measured by both passengers carried and RPKs.

7.6. ANFIS Model Evaluation Goodness of Fit Measures

According to Kunt et al (2011, p.356), "Goodness-of-fit (GOF) statistics are useful when comparing results across multiple studies, for examining competing models in a single study, and also for providing feedback on the level of knowledge about the uncertainty involved in the phenomenon of interest." Five measures were used in the ANFIS modelling: coefficient of determination (R^2), mean absolute error (MAE), mean absolute percentage error (MAPE) (Azadeh et al. 2010; Chen et al. 2010), mean square error (MSE) and root mean square error (RMSE) (Yetilmezsoy et al. 2011).



Figure 7.8. Australia's domestic LCC PAX actual and forecast values from the ANFIS model training phase.

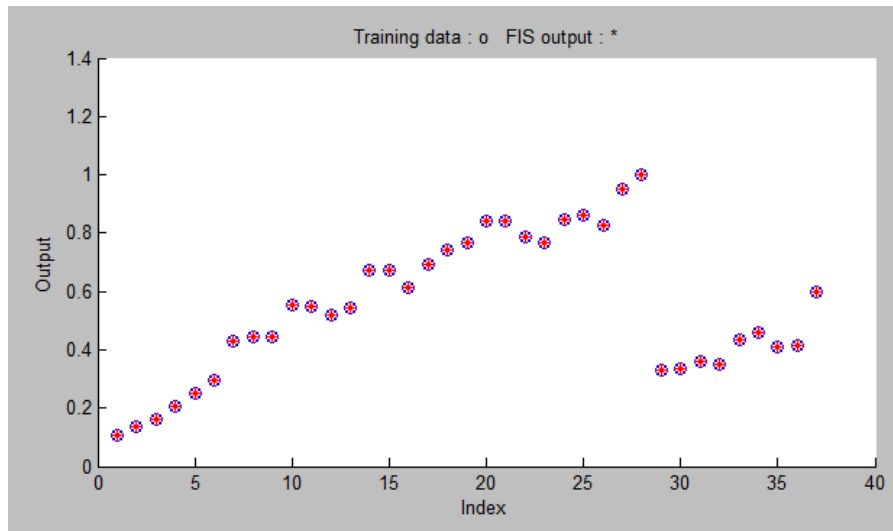


Figure 7.9. Australia's domestic LCC RPKs actual and forecast values from the ANFIS model training phase

For evaluating the ANFIS models, the mean absolute error (MAE), mean absolute percentage error (MAPE), mean square error (MSE), root mean squared error (RMSE), and coefficient of determination (R^2) were calculated using Equation (7.14) - Equation (7.18):

$$MAE = \frac{1}{N} \sum_{i=1}^N [|t_i - td_i|] \quad (7.14)$$

$$MAPE = \frac{1}{N} \left(\sum_{i=1}^N \left[\left| \frac{t_i - td_i}{t_i} \right| \right] \right) \times 100 \quad (7.15)$$

$$MSE = \frac{1}{N} \sum_{i=1}^N (t_i - td_i)^2 \quad (7.16)$$

$$RMSE = \sqrt{\frac{1}{N} \sum_{i=1}^N (t_i - td_i)^2} \quad (7.17)$$

$$R^2 = 1 - \left[\frac{\sum_{i=1}^n (t_i - td_i)^2}{\sum_{i=1}^n (t_i - \bar{t}_i)^2} \right] \quad (7.18)$$

where t_i is the actual values td_i is the forecast values, N is the total number of data points (Tiryaki & Aydın 2014, p. 104).

7.7 ANFIS Modelling Results

As earlier noted, this study utilized the Matlab's fuzzy inference toolbox to construct the ANFIS model. The gradient and LSE methods which were embedded in the Matlab software were used as the ANFIS training algorithms. In general, the basic computation process comprised four steps. Firstly, the model's input data which included input and output data were added to the system in the form of a data array (Chen et al. 2010). The second step was generation of a fuzzy inference system (FIS). Thirdly, the training function of the ANFIS model in Matlab's fuzzy inference toolbox for training the input data was utilized. In the ANFIS system, data training was operated automatically and training performance index such as RMSE was produced (Chen et al. 2010). Following the data training, and as the final step, an ANFIS model was obtained for output forecasting Australia's low cost domestic enplaned passengers and RPKs (Chen et al. 2010). Figure 7.10 presents Australia's domestic LCC passengers (PAX) and RPKs demand forecasting models. The ANFIS structure is based on the Sugeno FIS type.

The ANFIS was trained using Matlab with various possible combinations of the subtractive clustering parameters (range of influence (ROI) = 0.35-0.60, squash factor (SF) = 1.20-1.35, accept ratio (AR) = 0.40-0.55 and reject ratio (RR) = 0.10-0.20) for the range of epoch number from 1- 400 epochs. The constructed ANFIS model was manipulated until the best settings were obtained based on the lowest RMSE value. The hybrid learning algorithm was applied in the training phase. Data are normalized to the scale [0,1] to increase training performance. Training stopped when it reached the maximum epoch level or the training error target achieved (Yetilmezsoy et al. 2011).

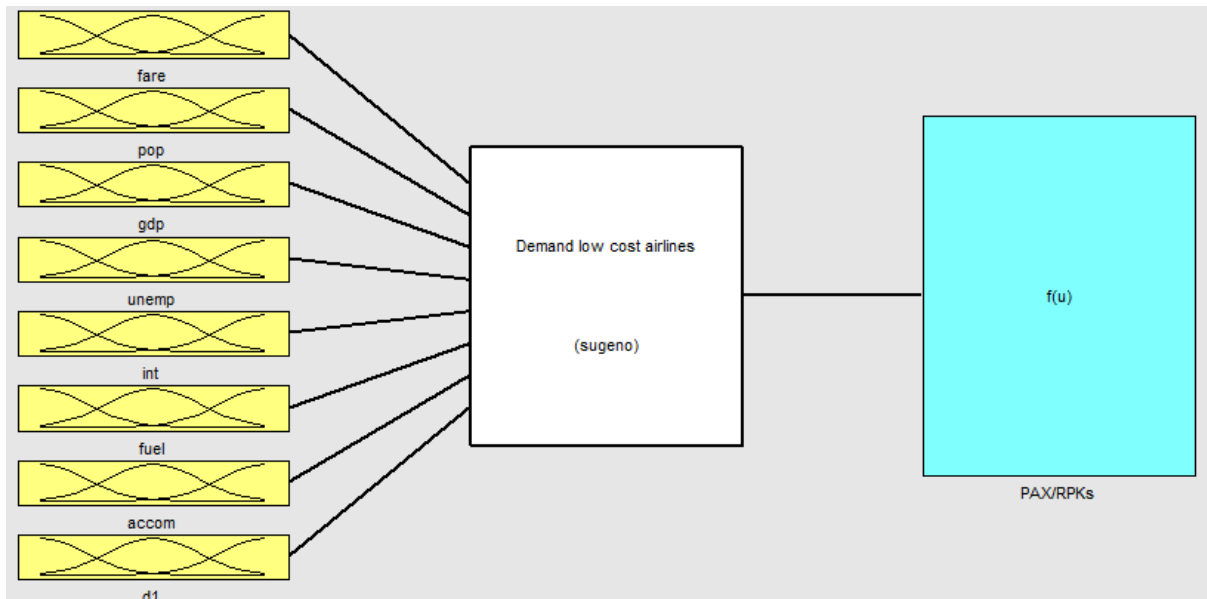


Figure 7.10. Australia's domestic LCC enplaned passengers (PAX) or RPKs ANFIS forecasting system structure

The RMSE steadied after running 50 epochs of PAX and RPKs training data. Final convergence values were 5.55×10^{-6} and 5.34×10^{-6} for the PAX and RPKs models, respectively.

The parameters in the subtractive clustering fuzzy inference system comprise the range of influence (ROI), squash factor (SF), accept ratio (AR) and reject ratio (RR)³² (Yetilmezsoy et al. 2011). The ANFIS models were operationalized by adjusting the subtractive clustering parameters around their default values systematically until the best settings were achieved on the basis of the lowest RMSE value (Yetilmezsoy et al. 2011). It is found that the optimum ANFIS structure of the PAX model with ROI = 0.45, SF = 1.25, AR = 0.50 and RR = 0.15 return the lowest value of RMSE at 5.55×10^{-6} and the RPKs model with ROI = 0.45, SF = 1.25, AR = 0.50 and RR = 0.15 return the lowest value of RMSE at 5.34×10^{-5} . The optimum ANFIS model architecture for forecasting Australia's domestic LCC enplaned passengers (PAX) or RPKs are shown Figure 7.10.

Following training, the ANFIS model for forecasting Australia's domestic LCC enplaned passengers and RPKs were validated by selecting six different observations, not included in the ANFIS training phase (Al-Ghandoor et al. 2012). Each validation data point was fed into

³² See Georgieva et al (2005, p. 90) for an overview of the range of influence (ROI), squash factor (SF), accept ratio (AR), and reject ratio (RR) in subtractive clustering inference systems.

the system and then Australia's forecast LCC enplaned passengers and RPKs values were computed and compared to the actual values.

The pattern of variation of actual and forecast data of both the PAX and RPKs models are shown in Figure 7.11 and Figure 7.12, respectively. The blue dots (+) in these two figures indicate the model's actual data and red dots (*) represent forecast data for the testing phase. The plots show actual and forecast data of both the PAX and RPKs model in the ANFIS testing phase are very close and reach the satisfactory RMSE at 0.047055 and 0.053875 for PAX and RPKs ANFIS models, respectively.

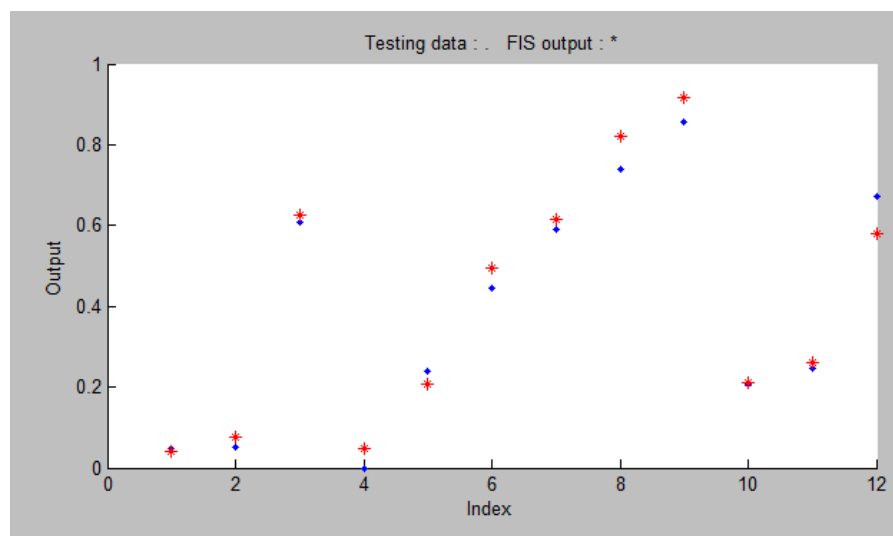


Figure 7.11. Australia's domestic LCC PAX model actual and forecast values during ANFIS testing phase

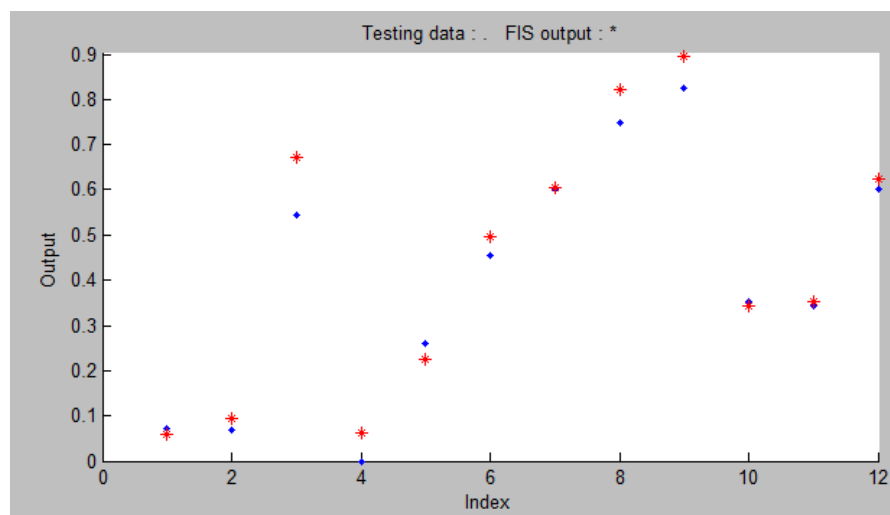


Figure 7.12. Australia's domestic LCC RPKs model actual and forecast values during ANFIS testing phase

Importantly, ANFIS can be used to identify the optimum combination of input parameter magnitudes to yield the best possible model output as it is possible with ANFIS to locate the actual optima (Sarkar et al. 2014).

A sample set of rule generation for forecasting Australia's domestic LCC enplaned passengers (PAX) and RPKs has been shown in Figure 7.13 and Figure 7.14, respectively. Figure 7.13 shows the forecast PAX value from the ANFIS to be 0.84 when the input parameters assume the following magnitudes: Australia's real best discount air fare = 0.48, Australia's population size = 0.48, Australia's real GDP = 0.58, Australia's unemployment size = 0.13, Australia's real interest rates = 0.98, world jet fuel prices = 1.0, Australia's tourist accommodation = 0.9, $D_1 = 0$.

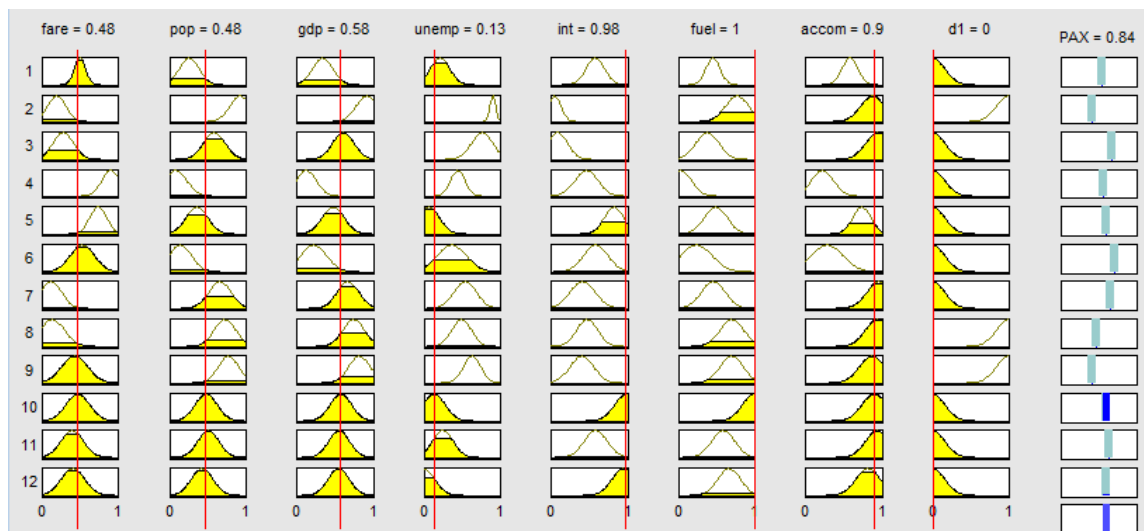


Figure 7.13. An example of a rule set for forecasting Australia's domestic LCC enplaned passengers (PAX Model)

Figure 7.14 shows that the forecast RPKs values from the ANFIS are 0.851, when the input parameters assume the following magnitudes: Australia's real best discount air fare = 0.26, Australia's population size = 0.59, Australia real GDP = 0.61, Australia's unemployment size = 0.76, Australia's real interest rates = 0.11, world jet fuel prices = 0.39, Australia's tourist accommodation = 0.95, and $D_1 = 0$.

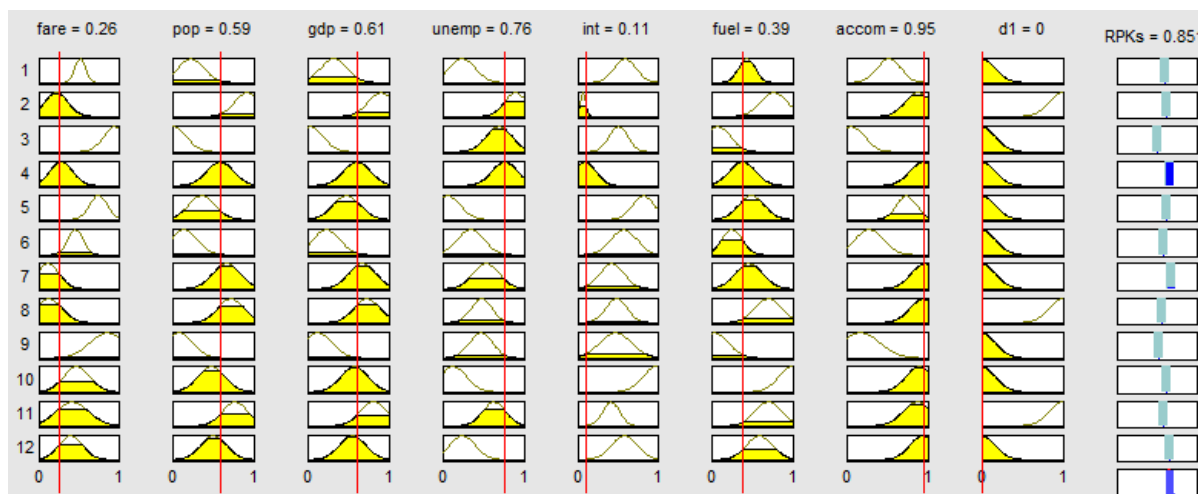


Figure 7.14. An example of a rule set for forecasting Australia's domestic LCC RPKs (RPKs Model)

The ability of an ANFIS to identify the optimum combination of input parameter magnitudes that yield the best possible output makes the ANFIS network all the more robust in its performance. This feature also ensures that ANFIS serves as a suitable and more effective forecasting approach to forecast the optimum conditions for a given multi-parameter reaction (Sarkar et al. 2014).

Surface graphs are obtained from the ANFIS to show the variation of output (in this study being either PAX or RPKs) with respect to two various parameters (X and Y-axis) (Figures 7.15-7.18) (Patil et al. 2011). In Figures 7.15 and 7.16, PAX is the same and these two figures depict the non-linearity and complexity associated in mapping input and output parameters of the ANFIS PAX model. Similarly, Figures 7.17 and 7.18, RPKs is the same and depicts the non-linearity and complexity associated in mapping input and output parameters of the ANFIS RPKs model.

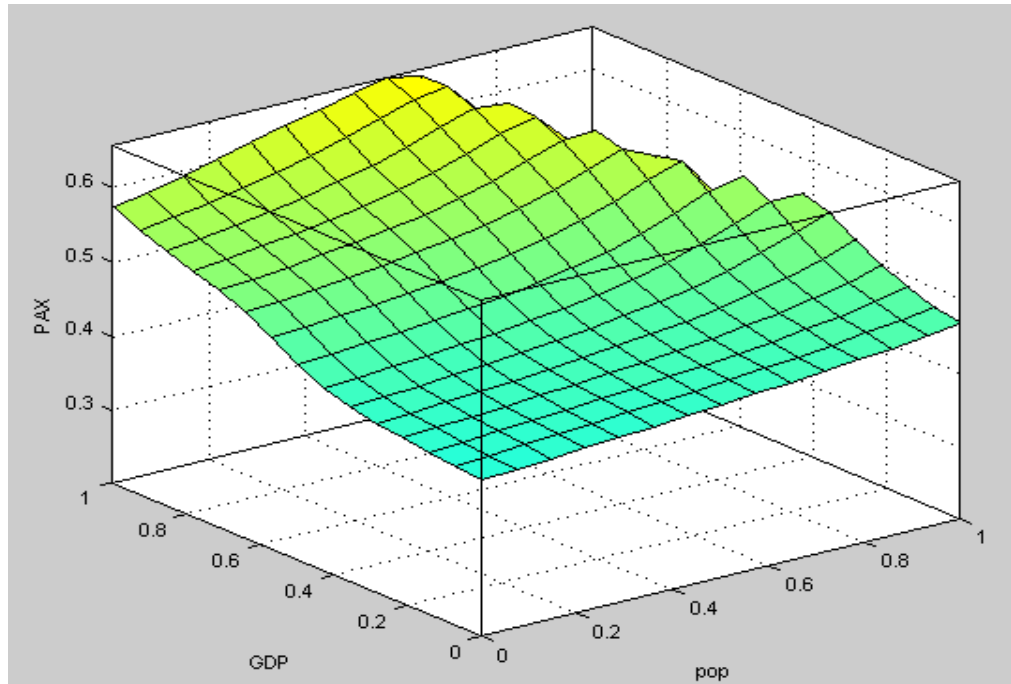


Figure7.15.Obtained surfaces in ANFIS PAX model: PAX versus Australia's population size and Australia's GDP

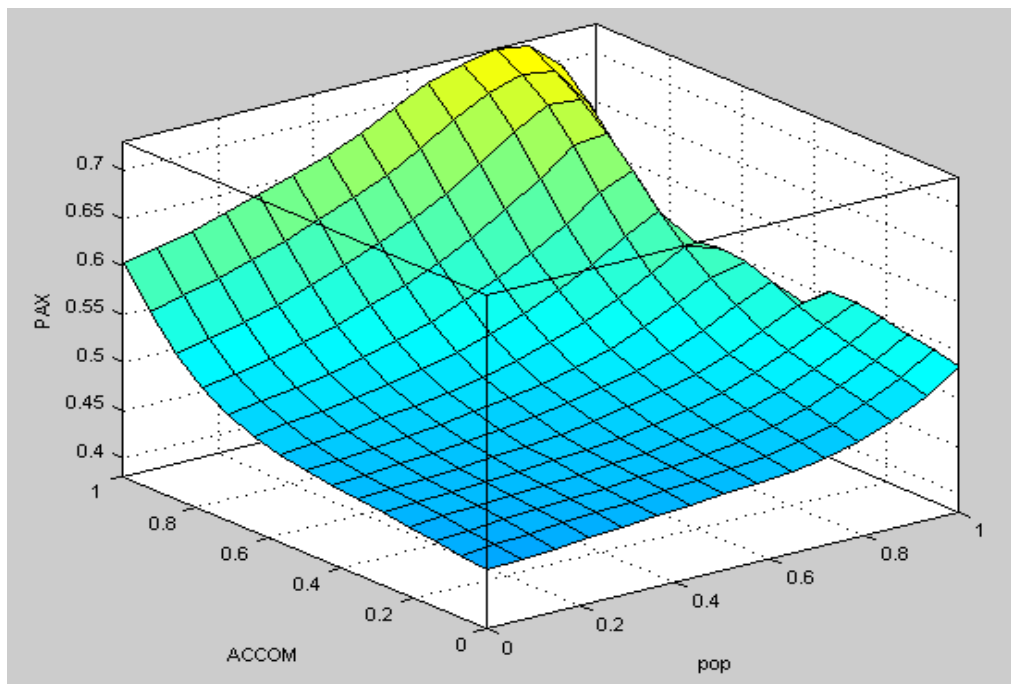


Figure7.16.Obtained surfaces in ANFIS PAX model: PAX versus Australia's population size and Australia's tourist accommodation

Figure 7.15 presents the relationship between LCCs enplaned passengers, Australia's GDP and population. It can be seen from this figure that Australia's GDP and population have positive relationship to LCCs enplaned passengers. Similar to figure 7.15, figure 7.16

presents the relationship between LCCs enplaned passengers, Australia's tourist accommodation and population. This figure also shows positive relationship between Australia's tourist accommodation and Australia's population to LCCs enplaned passengers.

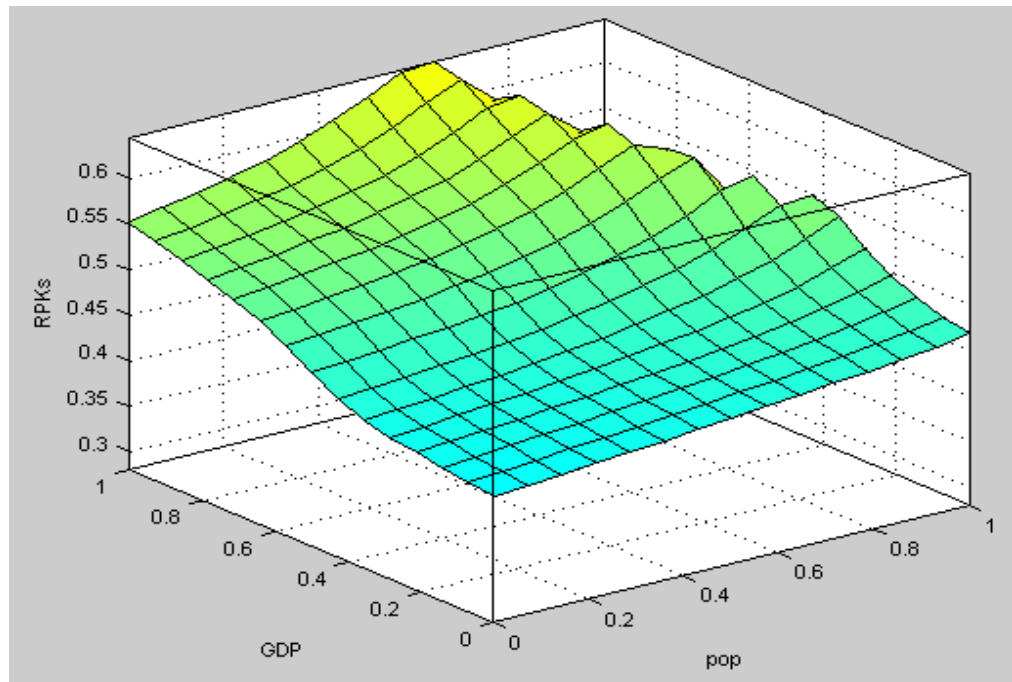


Figure7.17.Obtained surfaces in ANFIS RPKs model: RPKs versus Australia's population size and Australia's GDP

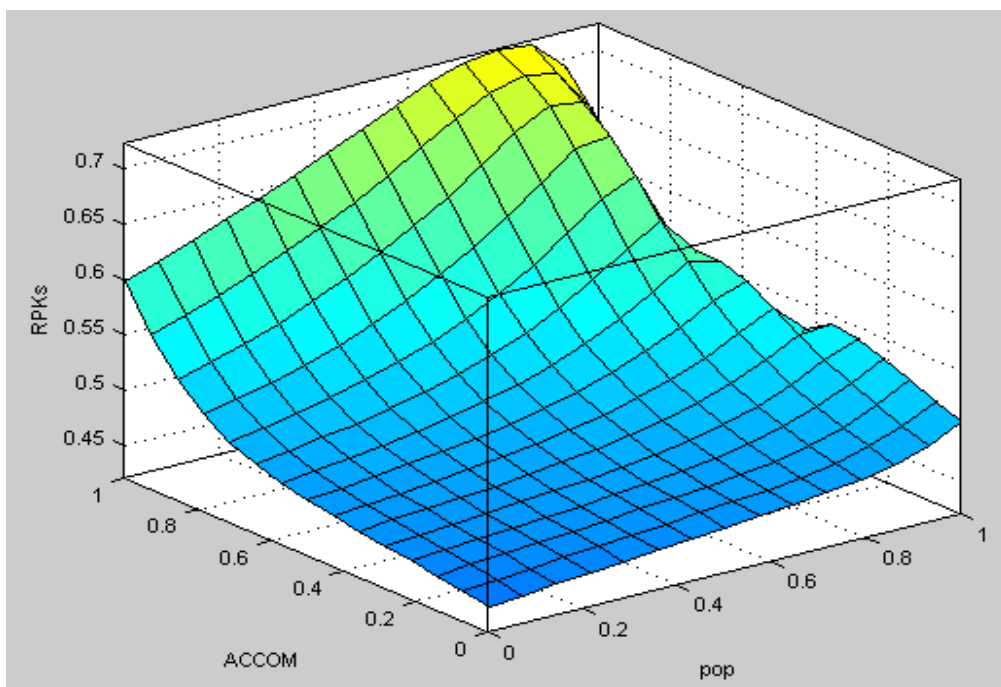


Figure7.18.Obtained surfaces in ANFIS RPKs model: RPKs versus Australia's population size and Australia's tourist accommodation

Figure 7.17 presents the relationship between RPKs, Australia's GDP and population. It can be seen from this figure that Australia's GDP and population have positive relationship to RPKs. Similar to figure 7.17, figure 7.18 presents the relationship between RPKs, Australia's tourist accommodation and population. This figure also shows positive relationship between Australia's tourist accommodation and Australia's population to RPKs.

The performance index of training, testing and overall data of the ANFIS PAX and RPK models were calculated as shown in Table 7.2. Table 7.2 shows that both the PAX and RPKs ANFIS models achieve a very satisfactory predictive accuracy and reliability. Both models show that MAE, MAPE, MSE, RMSE are very low for training, testing and overall data sets.

Table 7.2. Performance index of ANFIS PAX and RPKs models for training, out of sample testing and overall data sets

Performance index	PAX Model			RPKs Model		
	Train data	Test data	Overall data	Train data	Test data	Overall data
MAE	10.93	213.00	60.41	12.33	218.97	62.93
MAPE	0.21%	4.36%	1.23%	0.24%	5.55%	1.54%
MSE	2.4×10^2	7.1×10^4	1.8×10^4	3.0×10^2	8.2×10^4	2.0×10^4
RMSE	15.51	267.52	133.07	17.43	286.81	142.74

The overall forecast and actual value of Australia's domestic LCC enplaned passengers (PAX Model) and RPKs (RPKs Model) were regressed, and as Figure 7.19A and Figure 7.19B shows the R^2 are very high, being around 0.9937 and 0.9946 for PAX and RPKs models, respectively.

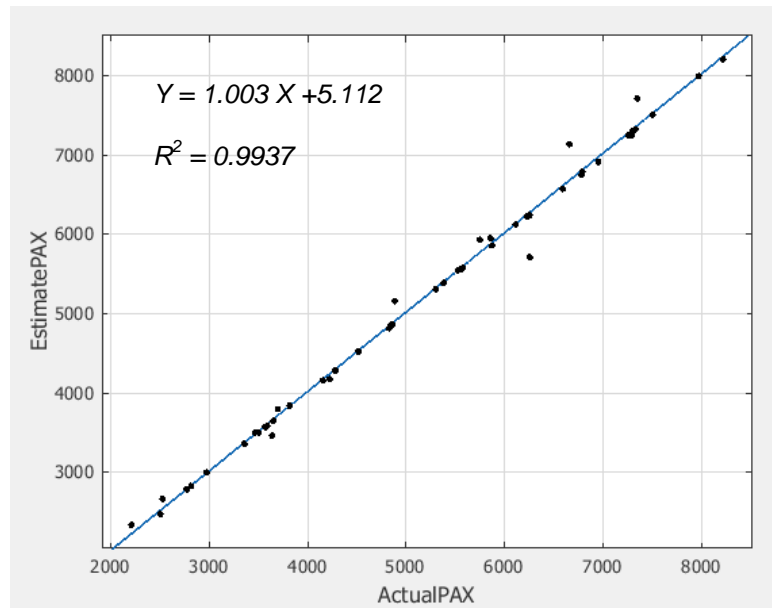


Figure 7.19A. Comparison of forecast and actual values of the ANFIS models for forecasting Australia's domestic LCC enplaned passengers (PAX)

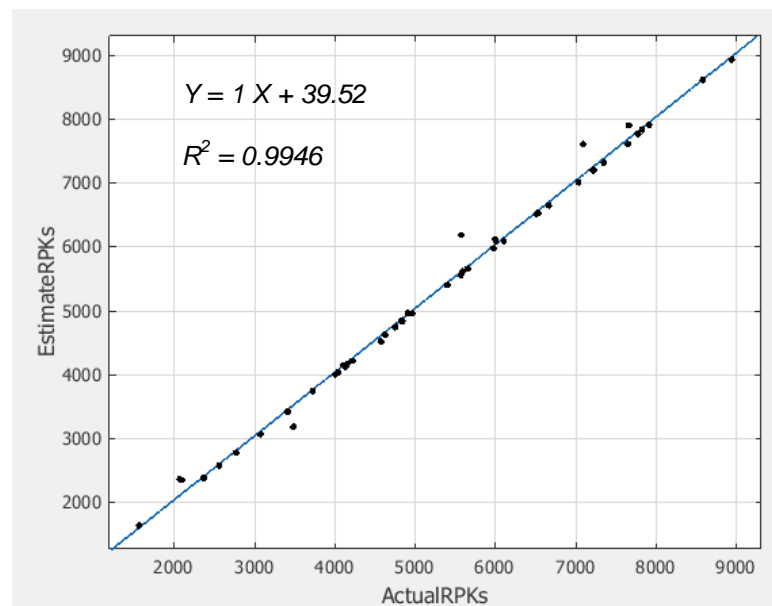


Figure 7.19B. Comparison of forecast and actual values of the ANFIS models for forecasting Australia's domestic LCC RPKs

The ANFIS PAX and RPKs models actual and forecast values are plotted in Figure 7.20 and Figure 7.21, respectively. It can be clearly seen from both these figures that the PAX and RPKs ANFIS models perform exceptionally well in forecasting Australia's domestic LCC passenger demand, as measured by both enplaned passengers and revenue passenger kilometres performed (RPKs).

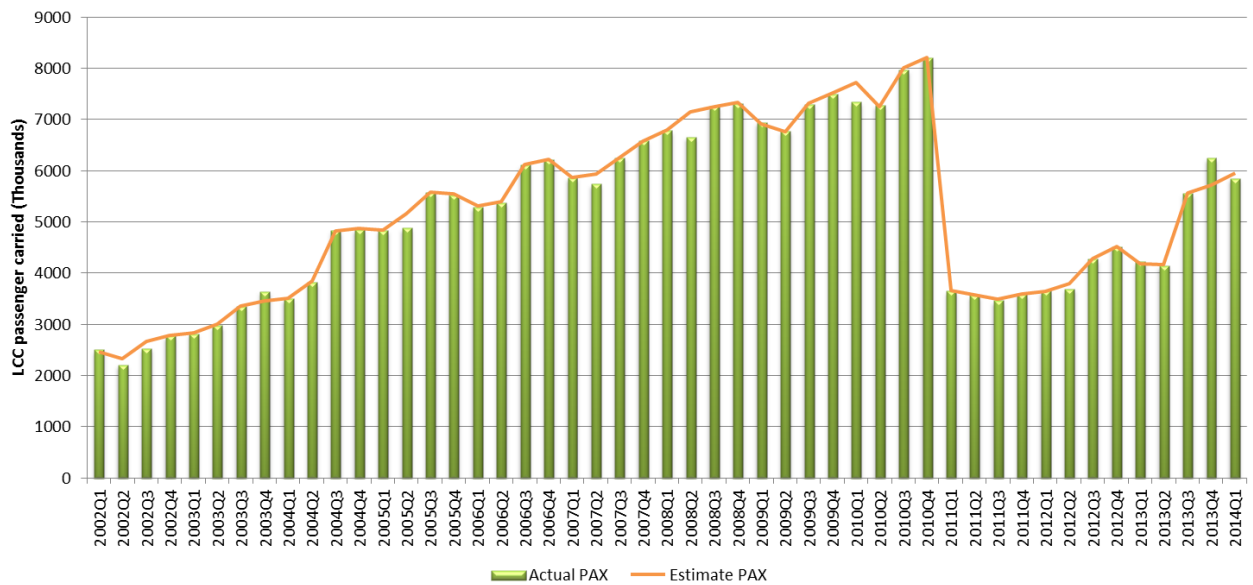


Figure 7.20.A comparison of Australia's domestic LCC actual and forecast enplaned passengers (PAX) (ANFIS Model)

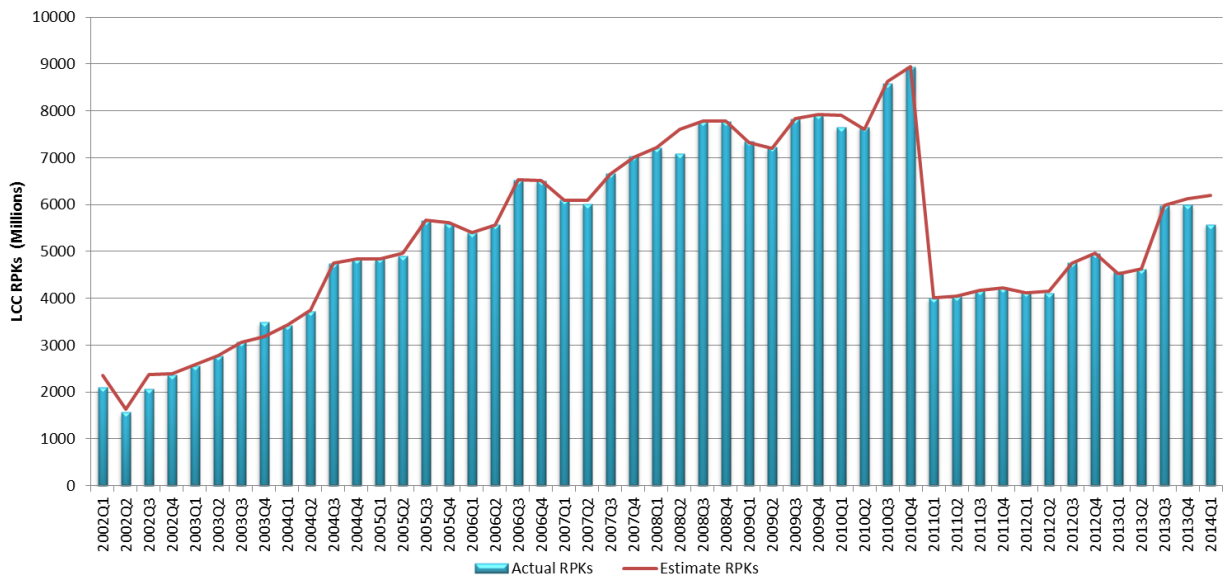


Figure 7.21.A comparison of Australia's domestic LCC actual domestic and forecast RPKs (ANFIS Model)

7.8 Summary

This chapter has proposed two ANFIS models for forecasting Australia's domestic LCC demand, as measured by enplaned passengers and revenue passenger kilometres performed (RPKs). Sugeno fuzzy rules were used in the ANFIS structure and Gaussian

membership function and linear membership functions were also developed. The hybrid learning algorithm and the subtractive clustering partition method were used to generate the optimum ANFIS models. Data was normalized to the scale [0,1] to increase the model's training performance. The results found that the mean absolute percentage error (MAPE) for the out of sample testing data set of Australia's domestic LCC enplaned passengers (PAX) and RPKs models were 4.36% and 5.55%, respectively.

It can be concluded that the ANFIS is an approach which can be used effectively to model and forecast Australian domestic LCC passenger demand. The originality of this study is use of the genetic algorithm and adaptive neuro fuzzy inference system (ANFIS) approach which has not been previously used to forecast Australia's domestic LCC passenger demand. The ANFIS models produced highly accurate and reliable results and showed a high forecasting capability.

CHAPTER EIGHT: EMPIRICAL RESULTS OF THE STUDY

8.1 Introduction

This thesis has been concerned with specifying and empirically testing models which can be used to forecast Australia's domestic LCC passenger demand. In order to achieve this aim, multiple linear regression (MLR) and three artificial intelligence-based forecasting models, were specified and empirically tested in the four previous chapters. The thesis also sought to achieve a greater understanding of the primary predictors of Australia's LCC passenger demand. The way in which a firm competes in its chosen markets influences its business model and strategic positioning. The 'original' LCC business models largely followed that of United States-based Southwest Airlines. However, over the past decade around the world the LCC business models have evolved quite dramatically in response to changing customer requirements. Thus, an important aim of this thesis was to explore whether Australia's domestic LCC have also moved towards a hybrid business model.

This chapter summarizes the empirical findings of the study. In so doing, it discusses the in-depth modelling undertaken in Chapters 4 to 7, and distinguishes the most accurate, reliable and capable approach for forecasting Australia's domestic LCC passenger demand. The chapter also discusses the principal socio-economic and air transport system variables of Australia's LCC passenger demand. The hybridization of Australia's domestic LCC market segment is also examined.

This chapter is structured as follows: Section 8.2 compares the in-depth modelling results, and identifies and justifies the best performing modelling approach for forecasting Australia's LCC passenger demand. Section 8.3 presents the principal predictors of Australia's LCC passenger demand. This is followed by an examination of the hybridization strategies adopted by Australia's domestic LCC over the past decade (Section 8.4).

8.2 Comparison of the Models and Selection of the Best Performance Model

Throughout this thesis, mention has been made of the critical importance of forecasting demand for airline management. This begs the question: what is the best model or forecasting approach available to airline management to forecast passenger demand? This

thesis aimed to examine this issue, and in order to do so, the following research question was proposed:

What forecasting methods are available for estimating Australia's domestic low cost carrier passenger demand and how do they differ in applicability and capability?

The thesis commenced with an in-depth examination of the forecasting methods that have previously been used in air travel demand forecasting. This comprehensive survey of the literature provided valuable insights into the traditional air travel demand forecasting methods, the most popular method being multiple linear regression models. The survey of the literature also identified new, and novel, artificial intelligence-based forecasting methods that could be used to forecast Australia's domestic LCC passenger demand. Consequently, four forecasting approaches were identified from the literature survey. This study therefore used a classical multiple linear regression (MLR), artificial neural network (ANN), genetic algorithm (GA), and the adaptive neuro fuzzy inference system (ANFIS) model to forecast Australia's domestic LCC passenger demand. Two measures of Australia's domestic LCC passenger demand were used in the study. The first measure was the number of Australia's domestic LCC enplaned passengers (PAX). The second measure was Australia's domestic LCC revenue passenger kilometres performed (RPKs) (Belobaba 2009; Holloway 2008).

This section is divided into two parts. Part A reviews the modelling results and answers the first research question. In the second part of this section (Part B), the second research question is addressed.

Part A

As we have previously noted, the factors that influence air travel demand are complex (Doganis 2009; Vasigh et al. 2008). Each factor is composed of elements that can stimulate or reduce air travel demand. For airline passenger traffic demand forecasting purposes, these factors are more conveniently categorised into two broad groups, those external to the airline industry and those within the airline industry itself (Ba-Fail et al. 2000). Thus, in order to identify the predictors of Australia's domestic LCC passenger demand, the study commenced with a comprehensive review of the extant literature, in order to identify the predictors of passenger demand that have been used in previous passenger air travel studies.

Based on the review of the literature and previous air travel demand forecasting studies, a total of eight independent variables were considered for testing in all the models. These independent variables are Australia's real best discount airfare (proxy for airline passenger yields), Australia's population size, Australia's real GDP, Australia's real GDP per capita, Australia's unemployment size, world jet fuel prices, Australia's real interest rates, and recorded bed capacities at Australia's tourist accommodation (a proxy to model the influence of tourism for Australia's domestic LCC).

Three dummy variables were also included in the models (study). The first dummy variable explained the impact of the evolving Virgin Australia business model from an LCC model to a full service network carrier (FSNC) (Whyte et al. 2012) on Australia's LCC traffic (enplaned passengers and RPKs). This is important because Australia's domestic LCC passenger traffic has decreased significantly since 2011. This decline in traffic is primarily due to the evolution in Virgin Australia's business model. Thus, the dummy variable reflecting the Virgin Australia changing business model (DUMMY 1) is zero for the period from Quarter 1 2002 to Quarter 4 2010 and one from Quarter 1 2011 to Quarter 1 2014.

The second dummy variable (DUMMY 2) accounted for the loss of capacity following the collapse of Ansett Australia in 2001. At the time of its collapse in 2001, Ansett Australia's domestic Australian market share was 35 per cent (Virgin Blue held around 10 per cent and Qantas had a 55 per cent market share) (Prideaux 2003). The collapse of Ansett Australia had a major impact on the tourism industry, especially in regional areas where Ansett's subsidiaries provided substantial capacity. Whilst the other incumbent airlines increased seating capacity, the demand for seats exceeded supply for several months (Prideaux 2003).

The third dummy variable (DUMMY 3) accounted for the impact of the Commonwealth Games held in Melbourne from 15 to 26 March, 2006. The 2006 Melbourne Commonwealth Games was the largest sporting and community event held in Victoria's history. The Commonwealth Games generated a total of 166,513 visitors. These visitors comprised 57,010 overseas visitors, 60,125 interstate visitors, 37,035 regional Victoria visitors and 12,343 other visitors (KPMG 2006).

As we noted above, the study used two income measures in the modelling: Australia's real GDP and real GDP per capita (GDP per capita is the gross domestic product divided by size of the population). Due to their direct relationship, gross domestic product (GDP) and GDP

per capita were not used as explanatory variables in the same model. Similarly, due to their direct relationship, population size and GDP per capita were not included in the same models (Ba Fail et al. 2000).

Prior to examining the thesis modelling results, it is important for us to note that, “Goodness-of-fit (GOF) statistics are useful for comparing modelling results, for examining competing models in a single study, and also for providing feedback on the level of knowledge about the uncertainty involved in the phenomenon of interest” (Kunt et al 2011, p.356). In this study, up to five key goodness of fit measures were used to compare the various modelling results and their performance: mean absolute error (MAE), mean absolute percentage error (MAPE), mean square error (MSE), the root mean square error (RMSE) and correlation coefficient (*R*). (see Section 4.4 for an overview of these GOF methods) (see, for example, Kunt et al. 2011; Yetilmezsoy et al. 2011; Ruiz-Aguilar et al. 2014; Tiryaki & Aydın 2014.)

To classify the forecasting accuracy of Australia’s domestic LCC passenger demand models, this study followed the forecasting accuracy classification as presented by Martin & Witt (1989), which has been cited in at least 84 other reported studies, that is, the forecasting performance of a model is considered ‘highly accurate forecasting’ when MAPE is smaller than 10 per cent ($MAPE < 10\%$). Forecasting accuracy is regarded as ‘good forecasting’ when the MAPE falls between 10-20 per cent ($10\% \leq MAPE \leq 20\%$), and it is classified as ‘reasonable forecasting’ where the MAPE is in the range of 20-50 per cent ($20\% \leq MAPE \leq 50\%$). Finally, if the MAPE is larger than 50 per cent the modelling results are considered to be ‘inaccurate forecasting’ (Martin & Witt 1989, p 417). The classification for MAPE is summarized and presented in table 8.1

Table 8.1. Classification for Mean Absolute Percentage Error (MAPE)

MAPE Value	Forecasting Accuracy
MAPE < 10%	Highly accurate forecasting
$10\% \leq MAPE \leq 20\%$	Good forecasting
$20\% \leq MAPE \leq 50\%$	Reasonable forecasting
MAPE > 50%	Inaccurate forecasting

Source : Adapted from Martin & Witt (1989, p 417).

The first model which was empirically examined in this study used a classical multiple linear regression (MLR) approach. The MLR has been extensively used in forecasting passenger air travel demand for air travel since 1950s. Interestingly, this approach has also been used in recent published air travel demand forecasting studies (see, for example, Kopsch 2012).

In light of the extensive use of this forecasting approach, and in the absence of any previously reported studies that have used such an approach to forecast Australia's domestic LCC passenger demand, the study developed and empirically tested two classical linear regression econometric models: one based on Australia's LCC enplaned passengers (PAX Model), and the second using revenue passenger kilometres performed (RPKs Model). In order to identify the most accurate and reliable MLR models, multiple linear regression assumptions including; a linear relationship between dependent and independent variables, normality of errors, autocorrelation, multi-collinearity and heteroschedasticity were tested for both the PAX and RPKs models. The results found that both models are very good in terms of Goodness of Fit measures and model accuracy. The MAPE of the MLR PAX model in estimating, testing and overall data are 5.00%, 8.63% and 5.89 %, respectively. The MAPE of the RPKs model in estimating, testing and overall data are 5.48%, 11.11% and 6.86%, respectively.

Following the development and testing of the two MLR models, the study turned its attention to potential artificial intelligence-based forecasting approaches: artificial neural networks (ANNs), genetic algorithm (GA), and adaptive neuro-fuzzy inference system (ANFIS) that could be used to forecast Australia's domestic LCC passenger demand. As highlighted in Chapter 1, in recent times these approaches have been increasingly used in various disciplines, and they have been considered to have superior predictive capabilities as compared to the traditional MLR forecasting approach (Garrido et al. 2014; Pan et al. 2013).

Hence, the second models tested in this study used the artificial neural network (ANN) approach. ANN models have been increasingly used across various disciplines for forecasting due to their predictive capabilities. However, there has been very few reported studies that have developed and tested ANNs for forecasting a country's domestic airline passenger demand, nor has there been any reported study that has proposed and empirically examined ANNs for forecasting Australia's domestic LCC passenger demand. Consequently, this study aimed to address this gap in the literature, and has specified and empirically examined two artificial neural networks models (ANNs) for forecasting Australia's domestic LCC passenger demand.

For the ANN model development, Australia's real best discount airfare, Australia's population size, Australia's real GDP, Australia's unemployment size, world jet fuel prices, Australia's real interest rates, recorded bed capacities at Australia's tourist accommodation establishments, and dummy variable reflecting Virgin Australia changing business model

(DUMMY 1) were selected as ANN inputs. The neural network used multi-layer perceptron (MLP) architecture that comprised a multi-layer feed-forward network. The sigmoid and linear functions were used as activation functions together with the feed forward-back propagation algorithm. The ANN used 70 per cent of the data set in the training phase and 15 per cent in the testing phase. In order to avoid an over-fitting problem the validation process was carried out through the ANN process using another 15 per cent of the data set. The optimum ANN structure had 8 inputs, 8 neurons in the hidden layers and 1 neuron in the output layer for both the PAX and RPKs ANN models. The overall *R*-values of Model 1 (PAX Model) was 0.9914, and Model 2 (RPKs Model) was 0.9954, respectively. Also, the MAPE of the ANN PAX model in the training, testing, and overall data are 3.61%, 4.91% and 3.93%, respectively, and in the RPKs model are 3.95%, 5.73% and 4.39% respectively.

The next modelling approach was based on a new, and novel, genetic algorithm. Despite their extensive use as a forecasting method in other disciplines, there has been no reported study that has proposed and empirically tested a genetic algorithm to forecast airline passenger demand. This thesis, for the first time, has introduced and empirically examined a new genetic algorithm for forecasting Australia's domestic LCC passenger demand. In order to undertake this modelling, the Matlab code for the GA models was developed specially for this study. Two mathematical forms were tested in the GA modelling including; linear, and quadratic GA models. Eleven inputs as tested in the ANN model were tested in the GA modelling. The results found that the quadratic GA models of both PAX and RPKS model produces better results than the linear GA model. The MAPE of the GA PAX model in training, testing, and overall data are 2.76%, 5.37% and 3.40% respectively, and in the RPKs model are 3.37%, 5.75% and 3.68%, respectively

The fourth approach used in this study is the adaptive neuro-fuzzy inference system (ANFIS) model. ANFIS is growing in popularity as a forecasting tool due to its greater accuracy and reliability together with their greater predictive capabilities. However, there has been no reported study that has proposed and empirically examined such an approach in the air travel demand study. This is also the first time that the ANFIS approach has been used for forecasting Australia's domestic LCC passenger demand. It has been noted in Chapter 1 that ANFIS have a high forecasting accuracy and ability. This is because they are a hybrid model which combine the advantages, and eliminate the disadvantages, of fuzzy and artificial neural network (ANN) model (Yetilmezsoy et al. 2011). Further, ANFIS is capable of handling complex and nonlinear problems when a more sophisticated system with high-dimensional data is implemented, the use of ANFIS instead of ANN is considered to be more

appropriate to more quickly overcome the complexity of the problem (Noori et al. 2009; Giovanis 2012).

In this study, two models, ANFIS PAX and ANFIS RPKs models were proposed. Sugeno fuzzy rules were used in the ANFIS structure and Gaussian membership function and linear membership functions were also developed. The subtractive clustering partition method was used to generate the optimum ANFIS PAX and ANFIS RPKs models. Data was normalized to the scale [0,1] to increase the model's training performance. The results found that the MAPE for the training, testing and overall data set of LCCs enplaned passengers (PAX) model were 0.21%, 4.36% and 1.23%, respectively, and in RPKs model were 0.24%, 5.55% and 1.54%, respectively.

Having described the models developed and tested, as well as their results, our attention turns now to a comparison of the models in order to identify the best performance model for forecasting Australia's domestic LCC passenger demand. Mean absolute error (MAE), mean absolute percentage error (MAPE), mean square error (MSE), and root mean squared error (RMSE) defined in equations (8.1) to (8.4) were utilised to evaluate the model performances.

$$MAE = \frac{1}{N} \sum_{i=1}^N [|t_i - td_i|] \quad (8.1)$$

$$MAPE = \frac{1}{N} \left(\sum_{i=1}^N \left[\left| \frac{t_i - td_i}{t_i} \right| \right] \right) \times 100 \quad (8.2)$$

$$MSE = \frac{1}{N} \sum_{i=1}^N (t_i - td_i)^2 \quad (8.3)$$

$$RMSE = \sqrt{\frac{1}{N} \sum_{i=1}^N (t_i - td_i)^2} \quad (8.4)$$

Table 8.2A presents a comparison of the forecasting accuracy in the training, out of sample testing, and overall data sets of Australia's domestic LCC PAX models. The table summarises the MAE, MAPE, MSE, and RMSE for each of the forecasting methods (MLR, ANN, GA and ANFIS). As can be observed from the comparison of these goodness of fit measures in the out of sample testing data set, ANFIS model is superior to the other models.

Table 8.2B ranks the forecasting accuracy of the modelling approaches used to test forecast Australia's domestic LCC enplaned passengers (PAX model). It can be seen that the forecasting accuracy of the ANFIS model is superior to the other forecasting approaches used in the study for the testing data set as measured by MAE, MAPE, MSE and RMSE values. This suggests that the ANFIS model is the best forecasting method approach to forecast the Australia's domestic LCC enplaned passenger (PAX). The ANN, GA, and MLR model are ranked second, third and fourth, respectively.

Table8.2A.A comparison of 4 models forecasting accuracy for Australia's domestic LCC PAX

Model	dataset	MAE	MAPE	MSE	RMSE
MLR	estimating	258.58	5.00%	9.6×10^4	310.43
ANN	training	182.66	3.61%	6.3×10^4	251.19
GA	training	139.42	2.76%	3.1×10^4	175.12
ANFIS	training	10.93	0.21%	2.4×10^2	15.51
MLR	testing	405.34	8.63%	3.0×10^5	544.28
ANN	testing	232.00	4.91%	1.1×10^5	327.74
GA	testing	242.95	5.37%	1.2×10^5	340.43
ANFIS	testing	213.00	4.36%	7.1×10^4	267.52
MLR	overall	294.53	5.89%	1.4×10^5	381.20
ANN	overall	194.74	3.93%	7.4×10^4	271.93
GA	overall	164.77	3.40%	5.1×10^4	227.02
ANFIS	overall	60.41	1.23%	1.8×10^4	133.07

Table8.2B.Forecasting accuracy's ranking of 4 Australia's domestic LCC PAX modelling

Model	dataset	MAE	MAPE	MSE	RMSE
MLR	estimating	4	4	4	4
ANN	training	3	3	3	3
GA	training	2	2	2	2
ANFIS	training	1	1	1	1
MLR	testing	4	4	4	4
ANN	testing	2	2	2	2
GA	testing	3	3	3	3
ANFIS	testing	1	1	1	1
MLR	overall	4	4	4	4
ANN	overall	3	3	3	3
GA	overall	2	2	2	2
ANFIS	overall	1	1	1	1

Table 8.3A presents a comparison of the forecasting accuracy in the training, out of sample testing, and overall data sets of Australia's domestic LCC RPKs models. The table summarises the MAE, MAPE, MSE, and RMSE for each of the forecasting methods (MLR, ANN GA, and ANFIS). As can be observed from the comparison of these goodness of fit measures in the out of sample testing data set, the ANFIS model is superior to the other models.

Table 8.3B ranks the forecasting accuracy of the modelling approaches used to test forecast Australia's domestic LCC RPKs (RPKs model). It can be clearly seen that the forecasting accuracy of ANFIS model is once again superior to the other forecasting approaches used in the study, as measured by MAE, MAPE, MSE and RMSE values. This suggests that the ANFIS model is the best forecasting method approach to forecast the Australia's domestic LCC RPKs. The ANN, GA and MLR model are ranked second, third and fourth, respectively.

Table8.3A.A comparison of 4 models forecasting accuracy for Australia's domestic LCC RPKs

Model	dataset	MAE	MAPE	MSE	RMSE
MLR	estimating	299.48	5.48%	1.2×10^5	352.35
ANN	training	200.99	3.95%	7.3×10^4	269.83
GA	training	159.01	3.37%	4.3×10^4	208.38
ANFIS	training	12.33	0.24%	3.0×10^2	17.43
MLR	testing	428.02	11.11%	2.4×10^5	495.31
ANN	testing	219.08	5.73%	8.5×10^5	292.11
GA	testing	276.30	5.75%	1.0×10^5	323.21
ANFIS	testing	218.97	5.55%	8.2×10^4	286.81
MLR	overall	330.96	6.86%	1.5×10^5	392.21
ANN	overall	205.42	4.39%	7.6×10^4	275.45
GA	overall	180.55	3.68%	5.5×10^4	233.74
ANFIS	overall	62.93	1.54%	2.0×10^4	142.74

Table 8.3B. Forecasting accuracy's ranking of 4 Australia's domestic LCC RPKs modelling

Model	dataset	MAE	MAPE	MSE	RMSE
MLR	estimating	4	4	4	4
ANN	training	3	3	3	3
GA	training	2	2	2	2
ANFIS	training	1	1	1	1
MLR	testing	4	4	4	4
ANN	testing	2	2	3	2
GA	testing	3	3	2	3
ANFIS	testing	1	1	1	1
MLR	overall	4	4	4	4
ANN	overall	3	3	3	3
GA	overall	2	2	2	2
ANFIS	overall	1	1	1	1

Therefore, based on the widely cited Martin and Witt (1989) MAPE values classifications, all Australia's domestic LCC PAX and RPKs models can be considered as "highly accurate forecasts" except the MLR RPKs model which can be considered as "good forecasting".

Figure 8.1 and 8.2 presents the actual output values of Australia's domestic LCC enplaned passengers and RPKs with the forecast values of the models tested in the study. This graphical presentation highlights a considerable overlap between the real and forecast outputs from the MLR, GA, ANN and ANFIS models indicating that the ANFIS models successfully forecast Australia's domestic LCC passenger demand with a high level of accuracy. The comparison of the modelling results shows that the performance of the ANFIS was superior and offers highly improved forecasting over the classical MLR, GA and ANN models.

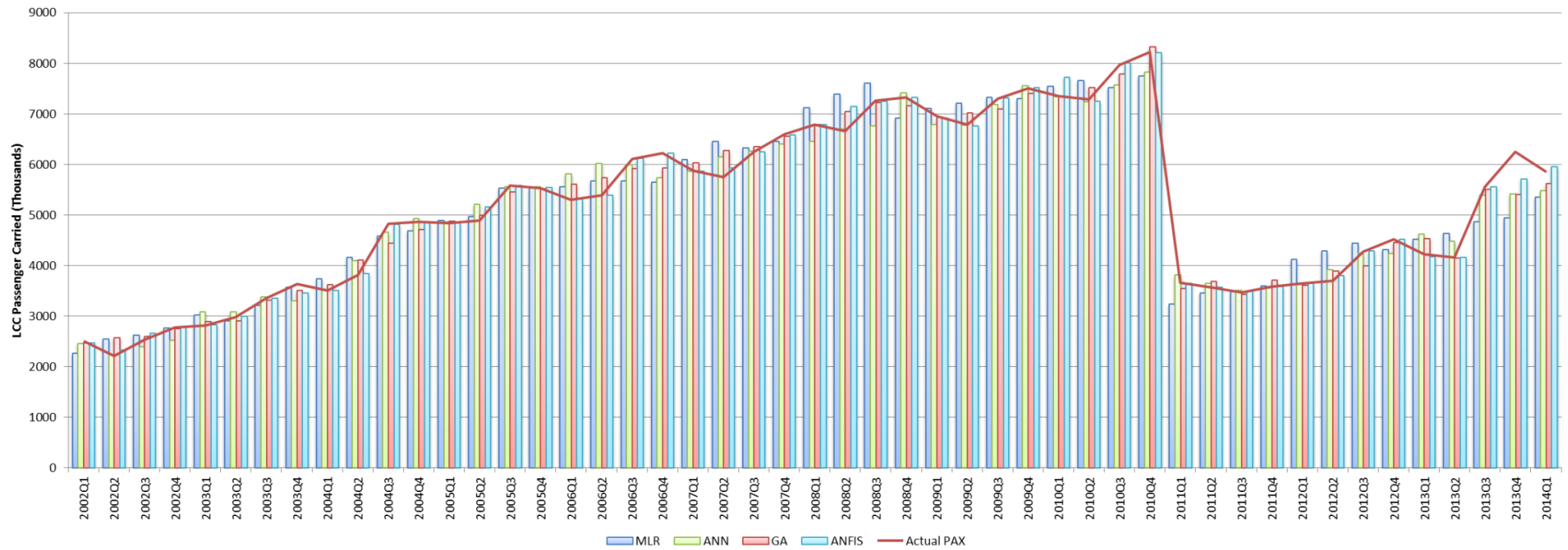


Figure8.1.A comparison of Australia's domestic LCC MLR, GA, ANN and ANFIS actual and forecast PAX models

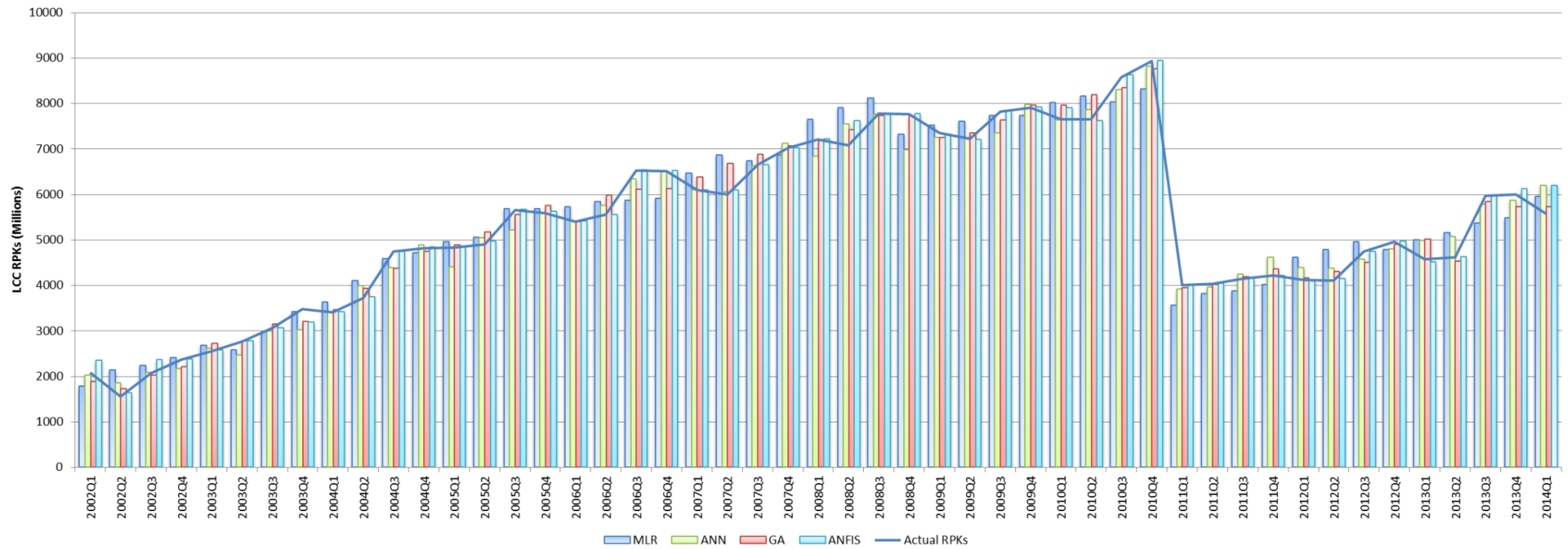


Figure 8.2.A comparison of Australia's domestic LCC MLR GA, ANN and ANFIS actual and forecast RPKs models

Part B

The preceding part of this section focussed on addressing the first research question and highlighted the fact that there are multiple forecasting methods available to airline management to forecast passenger demand. Importantly, the modelling results showed that these modelling approaches do differ in applicability and capability. The artificial neuro-fuzzy inference system (ANFIS) method proved to have the most predictive capability, accuracy and reliability. In the following we turn our attention to the study's second research question:

How do artificial intelligence-based forecasting models perform in terms of accuracy and reliability in low cost carrier passenger demand forecasting as compared to the traditional multiple linear regression approach?

The literature survey on air travel demand forecasting highlighted the fact that in recent times artificial based intelligence forecasting methods have attracted some research attention. The artificial neural network (ANN) approach was used by Alekseev and Seixas (2002, 2009) to forecast Brazil's domestic air travel demand. In a further study, Blinova (2007) proposed an artificial neural network model for forecasting Russia's air travel demand. Other artificial intelligence-based forecasting methods include genetic algorithm and the artificial neuro-fuzzy inference system (ANFIS) methods. As we have noted, there have been no reported studies that have proposed and empirically tested a genetic algorithm for forecasting air travel demand. Nor, has there been any previous reported study that has proposed and empirically examined a country's domestic air travel demand using the artificial neuro-fuzzy inference system (ANFIS) method.

It has been argued in the literature that artificial intelligence-based forecasting methods offer a number of advantages when compared to the traditional multiple linear regression modelling approach. The primary advantage of artificial neural networks (ANN) over other forecasting methods is that the network equally well predicts the processes whose regular components have any distribution law, whereas most other forecasting methods are best suited for processes that possess a regular component that belongs to a specific class (clearly, the method of polynomial smoothing is best suited for processes with a polynomial regular component, the method of smoothing by Fourier series is best suited for processes with a periodic regular component and so forth). A further advantage of ANNs is their ability to learn (Aizenberg 2011; Mrugalski 2013; Sineglazov et al. 2013). Artificial neural networks (ANN) also have the ability of mapping any linear or non-linear function and having no

associated data assumption requirements (Claveria & Torra 2014; Kunt et al. 2011; Santos et al. 2014).

The Adaptive Neuro-Fuzzy Inference System (ANFIS), first introduced by Jang (1993), is a hybrid method comprising both fuzzy inference systems with the artificial neural network (ANN) (Fang 2012; Liu et al. 2008). This system therefore combines the benefits of both approaches; wherein the former brings prior knowledge into a set of constraints to obtain the optimal solution, while the latter is good at capturing various patterns (Jang et al. 1997; Xiao et al. 2014; Yetilmezsoy et al. 2011). An ANFIS's principal objective is the determination of the optimum values of equivalent fuzzy inference system parameters. This is achieved through application of a learning algorithm using input–output data sets. Optimisation of parameters is undertaken in such a way during the training session that the error between the target and actual output is minimized (Goyal et al. 2014).

ANFIS is considered a more powerful approach than the simple fuzzy logic algorithm and artificial neural networks as this technique provides a method whereby fuzzy modelling learns about the data set; in order to compute the membership function parameters which best allow the associated fuzzy inference system to track the given input/output data (Al-Ghandoor et al. 2012, p. 130). A further advantage of ANFIS is the fact that it can be trained without the requirement for the expert knowledge normally required for the standard fuzzy logic design, and both numerical and linguistic knowledge can be combined into a fuzzy rule base by utilising fuzzy methods (Giovanis 2012). Other important advantages of ANFIS include its nonlinear ability, its capacity for rapid learning, and its adaptation capability. Furthermore, the strength of ANFIS is that it uses the artificial neural network's ability to classify data and identify patterns (Giovanis 2012). Moreover, ANFIS develops a fuzzy expert system that is more transparent to the user and which is also less likely to produce memorization errors than an ANN (Giovanis 2012).

Artificial neural network-based methods have been used successfully for modelling across a broad range of disciplines (Yetilmezsoy et al. 2011). However, poor interpretation has been reported as a major drawback of their utilization (Wieland et al. 2002). A major shortcoming of artificial neural networks (ANNs) is that they are unable to reveal causal relationships between major system components. Consequently, they are unable to improve the user's explicit knowledge (Yetilmezsoy et al. 2011). Therefore, to overcome the problematic conditions of ANNs and fuzzy systems, a new system combining both ANNs and the fuzzy

system, called adaptive-network-based fuzzy inference system (ANFIS) was proposed by Jang (1993).

Genetic algorithm (GA) is powerful stochastic search techniques that are based on the principle of natural evolution (Kunt et al. 2011). GA differs substantially from traditional optimization methods because they search for the population of points in parallel rather than a single point in order to obtain the best solution. Therefore, they provide several potential solutions to a given problem under study and the choice of the final solution is left to the user (Akgüngör & Doğan 2009).

The principal strength of GA is their adaptive and self-organizing capabilities. These abilities enable GA to quickly solve difficult problems through three evolutionary mechanisms: (1) selection, (2) crossover, and (3) mutation (Hu 2002). The basic operations of GA include selection, a crossover of genetic information between reproducing parents and a mutation of genetic information which affect the binary strings characteristic in natural evolution (Ozturk et al. 2005). If GAs are suitably encoded, then they can be used to solve real world problems by mimicking this process (Akgüngör & Doğan 2009).

Table 8.2A, Table 8.2B, Table 8.3A, and Table 8.3B above, presents a summary of the study's modelling results. Based on the goodness of fit measures (MAE, MAPE, MSE, RMSE) that can be used to compare different modelling approaches (Kunt et al. 2011), the three artificial intelligence-based forecasted approaches tested in this study were clearly shown to provide more accurate and reliable LCC passenger demand forecasts. The modelling results of all three artificial intelligence-based methods were therefore superior when compared to the traditional multiple linear regression approach. This suggests that artificial intelligence-based forecasting methods provide more accurate and reliable forecasts.

Hypothesis test

This study further employed a hypothesis test to give an indication if the difference between the artificial intelligence-based forecasting models and the traditional multiple linear regression models was in fact statistically significant. Since the same 12 out of sample testing data set were used for forecasting in all models, the paired *t*-test (two samples for mean) was used to assess the forecasting accuracy of the models and also to test the hypothesis (H_0) that there is not a significant difference in the forecasting accuracy of the

MLR vs ANN, MLR vs GA and MLR vs ANFIS models (Razi and Athappily, 2005; Zaefizadeh et al. 2011). The results of t-tests are presented in Table 8.4.

Table 8.4. Results of paired t-tests

Test	<i>t-stat</i>	<i>P-value</i>	Conclusion
PAX H_{01} : MLR vs ANN	2.11	.0029	$\mu_{MLR} > \mu_{ANN}$
PAX H_{02} : MLR vs GA	3.14	0.005	$\mu_{MLR} > \mu_{GA}$
PAX H_{03} : MLR vs ANFIS	2.17	0.026	$\mu_{MLR} > \mu_{ANFIS}$
RPKs H_{04} : MLR vs ANN	2.29	0.021	$\mu_{MLR} > \mu_{ANN}$
RPKs H_{05} : MLR vs GA	2.95	0.007	$\mu_{MLR} > \mu_{GA}$
RPKs H_{06} : MLR vs ANFIS	2.18	0.026	$\mu_{MLR} > \mu_{ANFIS}$

Where μ_{MLR} , μ_{ANN} , μ_{GA} , and μ_{ANFIS} are mean forecasting error of MLR, ANN, GA and ANFIS models, respectively

Table 8.4 shows that the *p-values* (one-tail) for PAX models H_{01} is 0.029, H_{02} is 0.005, H_{03} is 0.026 and for RPKs models H_{04} is 0.021, H_{05} is 0.007, H_{06} is 0.026, therefore the hypothesis H_{01} , H_{02} , H_{03} , H_{04} , H_{05} , and H_{06} which state that there is not a significant difference in the forecasting accuracy of the MLR vs ANN, MLR vs GA and MLR vs ANFIS models are rejected. This implies that the average forecasting error of the traditional multiple linear regression models is statistically significantly different from the average forecasting error of the artificial intelligence-based forecasting models (ANN, GA and ANFIS) at the 95 per cent confidence interval of the difference. The results indicated that the forecasting error of MLR models is higher than the ANN, and ANFIS models.

These results also confirm that the artificial intelligence-based forecasting models provide more accurate and reliable as compared to the traditional multiple linear regression model when used to forecast Australia's domestic airline enplaned passengers (PAX) and revenue passenger kilometres (RPKs), respectively.

8.3 The Primary predictors of Australia's Low Cost Carrier Domestic Air Travel Demand

As noted in Section 4.4 that in the standard air transport modelling and forecasting approach, two vectors including socio-economic and air transport system vector, are used and combined through mapping, so that the target demand forecasting can be accomplished (Alekseev & Seixas 2009; Rengaraju & Arasan 1992).

The comprehensive review of the literature on previous air travel demand forecasting studies reported in the leading journals showed that the socio-economic and air transport system vectors influencing air travel demand were real GDP, real GDP per capita, population and air fares. Other important factors that influence air travel demand reported in the literature include unemployment (McKnight 2010), tourism demand (Davidson & Ryley 2010; Graham 2006; Koo et al. 2013) and real interest rates (Cook 2007; Wensveen 2011). However, the five reported studies that focussed on forecasting Australia's air travel demand (3 domestic and 2 international) did not include the latter three variables in the proposed and tested forecasting models.

A key aim of this study was therefore to explore the predictors of Australia's domestic LCC passenger demand in order to achieve a greater understanding of the factors which influence the Australia' domestic LCC air travel demand. Thus, in order to obtain a greater awareness of the factors that may influence Australia's domestic LCC passenger demand, the following research question was asked:

What are the principal predictors of Australia's domestic LCC's passenger demand?

Based on the review of the literature and previous air travel demand forecasting studies, socio-economic and air transport system vectors comprised eight independent variables were considered for testing Australia's domestic LCC passenger demand models. The models were measured by the number of Australia's LCC domestic enplaned passengers (PAX Model), and Australia's LCC domestic revenue passenger kilometres performed (RPKs Model) (Belobaba 2009; Holloway 2008). These independent variables are Australia's real best discount airfare (proxy for airline passenger yields), Australia's population size, Australia's real GDP, Australia's real GDP per capita, Australia's unemployment size, world jet fuel prices, Australia's real interest rates, recorded bed capacities at Australia's tourist

accommodation and three dummy variables reflecting Virgin Australia changing business model, the collapse of Ansett Australia, and the Commonwealth Games in 2006.

Table 8.5 presents a summary of the independent variables that were included each of the modelling approaches. We will examine each in turn.

Table 8.5.A summary of the independent variables included in the MLR, GA, ANN and ANFIS PAX and RPKs models

Variables	MLR	GA	ANN	ANFIS
Australia's real best discount airfare	✓	✓	✓	✓
Australia's population size	-	✓	✓	✓
Australia's real GDP	-	✓	✓	✓
Australia's real GDP per capita	✓	-	-	-
Australia's unemployment size	-	✓	✓	✓
World jet fuel prices	✓	✓	✓	✓
Australia's real interest rates	✓	✓	✓	✓
Recorded bed capacities at Australia's tourist accommodation	-	✓	✓	✓

8.3.1 Australia's real best discount air fares

Price of travel options has an important impact on total air travel demand. The monetary (out of pocket costs) prices of airline fares, together with the implied disutility costs of air fare restrictions (for example, the requirement to stay over on a Saturday night and non-refundability of tickets), are perhaps the most critical predictors of the volume of air travel demand (Belobaba 2009).

Australia's domestic LCC principally focus on Australia's leisure air travel market. In the leisure air travel market, the dominant requirement is for cheap air fares. This is due to a number of important reasons. Unlike in the corporate or business travel air travel market sub-segment, leisure travellers are spending their own money on their travel requirements. Their travel expenditure is typically not tax-deductible in the way that benefits a traveller who is independent of a corporate traveller. Often, too, leisure travel is undertaken as a family group. In such circumstances, the amount of cash payable will be multiplied several times over to account for each family member travelling, thereby making access to cheap air fares even more important. Finally, in the leisure travel market segment suffer from what Shaw

(2011, p. 41) calls “being at the back of the queue in terms of people being willing to pay more”. When a family is travelling on a holiday a decision has to be taken as to spending money on a luxurious but expensive flight, or on a good high quality hotel and meals at their chosen destination(s). Not surprisingly, in many cases, a decision is made to focus expenditure at the destination, because people may be staying at the destination for a fortnight or more, as opposed to travelling in an aircraft for just a few hours (Shaw 2011).

The marketing strategies of Australia’s domestic LCC place a high emphasis on the provision of “cheap air fares” or “low air fares”. This is very much exemplified in Jetstar Airways, Australia’s largest domestic LCC, mission statement: *Jetstar’s mission is to offer all day, every day low fares to enable more people to fly to more places, more often* (Jetstar Airways 2014). Tigerair Australia also promotes itself as an airline that offers “affordable travel options” (Tiger Airways Holdings 2014a).

An important part of the modelling undertaken in this thesis was to explore the significance of air fares as a predictor of Australia’s domestic LCC passenger demand. This was significant because there has been no reported study that has examined and tested the relationship between Australia’s real best discount air fares and its influence on Australia’s domestic LCC passenger demand. Australia’s real best discount air fare was used as a proxy for the monetary cost of LCC air travel in Australia. As can be seen in Table 8.5, Australia’s real best discount air fares proved to be a predictor variable in all four modelling approaches undertaken in the study.

The coefficient of Australia’s real best discount air fares was found to be (-16.49) in the MLR PAX and (-18.79) in the RPKs models, and (-5.28) in the $GAPAXDE_{lin}$ model, and (-3.58) in the $GARPKSDE_{lin}$ model, respectively. Australia’s real best discount air fares was also shown to be an important predictor variable in the ANN models with the contribution value of 4.64 and 5.92 in the PAX and RPKs model, respectively.

In addition, the demand price elasticity can be obtained by converting the MLR PAX and RPKs models to double log linear form where the estimated coefficient represented demand price elasticity (Vasigh et al. 2013). The double-log linear regression for PAX and RPKs models are presented as following;

$$(1): \ln PAX = -9.51 - 0.55 \ln X_1 + 2.13 \ln X_2 - 0.14 \ln X_3 + 0.49 \ln X_4 - 0.86 \ln X_5 \text{ and}$$

$$(2): \ln RPKs = -14.44 - 0.70 \ln X_1 + 2.70 \ln X_2 - 0.08 \ln X_3 + 0.56 \ln X_4 - 0.84 \ln X_5$$

Where PAX is Australia's domestic LCC enplaned passengers, RPKs is Australia's domestic LCC revenue passenger kilometres performed, X_1 is airfare (Australia's real best discount air fare), X_2 is Australia's real GDP per capita, X_3 is Australia's real interest rates, X_4 is World jet fuel price, and X_5 is dummy variable (DUMMY 1) reflecting Virgin Australia's changing business model.

The coefficient of airfare indicated that a 10 per cent decrease in airfare would increase the Australia's domestic LCC enplaned passengers by 5.5 per cent and a 10 per cent decrease in airfare would increase the Australia's domestic LCC RPKs by 7.0 per cent. Since the model was expressed in double-log form, the airfare coefficient represented an estimate of airfare elasticity. According to the absolute value of the airfare coefficient in PAX and RPKs models which are less than one, (-0.55) in PAX model and (-0.70) in RPKs model, it is suggested that Australia's domestic LCC passenger is price inelastic (Li 2010). The implication being that an increase in airfare will result in a less than proportionate decrease in the quantity demanded and the total revenue will increase (Li 2010).

The ANFIS models were tested with and without Australia's real best discount air fares as a predictor variable. In this modelling approach, both the PAX and RPKs models were found to be more accurate and reliable, and provided a greater forecasting capability when Australia's real best discount air fares was included as a predictor variable in the models. The findings therefore support the literature (see, for example, Belobaba 2009; Doganis 2009; Shaw 2011) and show that Australia's real best discount air fares is an important predictor of Australia's domestic LCC passenger demand, as measured by both enplaned passengers and revenue passenger kilometres.

To demonstrate the importance of the relationship between Australia's real best discount and the Australia's domestic LCC passenger demand (both enplaned passengers and RPKs), the data are plotted in Figure 8.3.

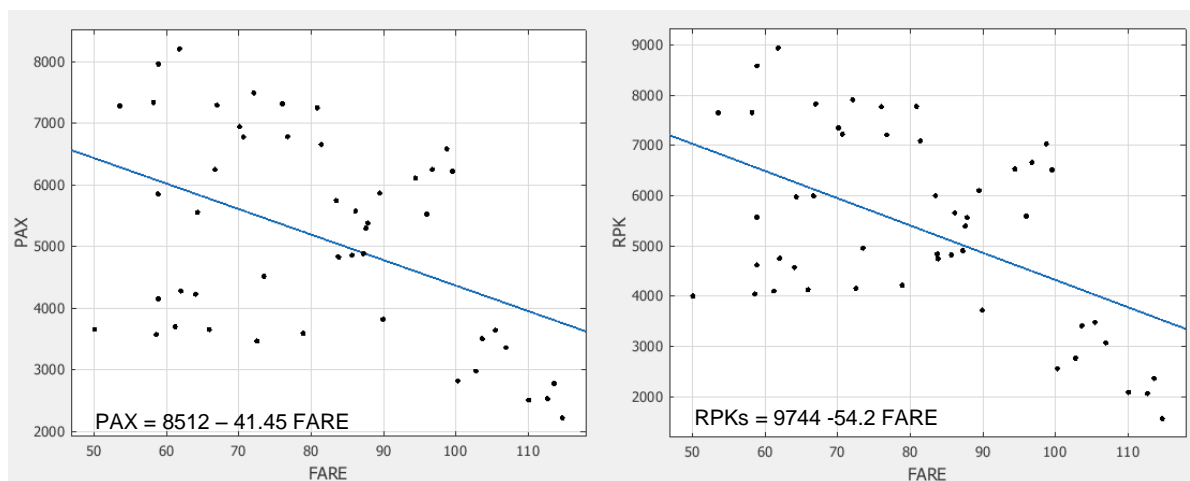


Figure 8.3. The relationship between Australia's real best discount air fares and Australia's domestic LCC passenger demand

8.3.2 Australia's population size

It has been suggested that population has a direct effect on the size of an air travel market and may cause a bias in the estimates if omitted. For instance, a large increase in air traffic may reflect a sudden increase in population rather than other effects (International Air Transport Association 2008). Australia's population size was included as a predictor variable in the study's genetic algorithm (GAPAXDE and GARPKSDE models), artificial neural network (ANN), and artificial neuro-fuzzy inference system (ANFIS) PAX and RPKs models. The coefficient of Australia population size was found to be 0.0004 in the $GAPAXDE_{in}$ model, and 0.0005 in the $GARPKSDE_{in}$ model, respectively. Australia's population size was also shown to be an important predictor variable in the ANN models with the contribution value of 6.84 and 6.66 in the PAX and RPKs model, respectively. The ANFIS models were tested with and without Australia's population size as a predictor variable. In this modelling approach, both the PAX and RPKs models were found to be more accurate and reliable, and provided a greater forecasting capability when Australia's population size was included as a predictor variable in the models.

An explanation for the importance of the growth in Australia's population size as a predictor of Australia's domestic LCC passenger growth is that over the duration of the period of the study (2002-2012), Australia's population has increased from 19,453,400 in 2002 to 22,728,300 in 2012. Clearly, this growth has increased has the potential size of Australia's domestic air travel market. In order to highlight the importance of the relationship between

Australia's population size and the Australia's domestic LCC passenger demand (both enplaned passengers and RPKs), the data are plotted in Figure 8.4.

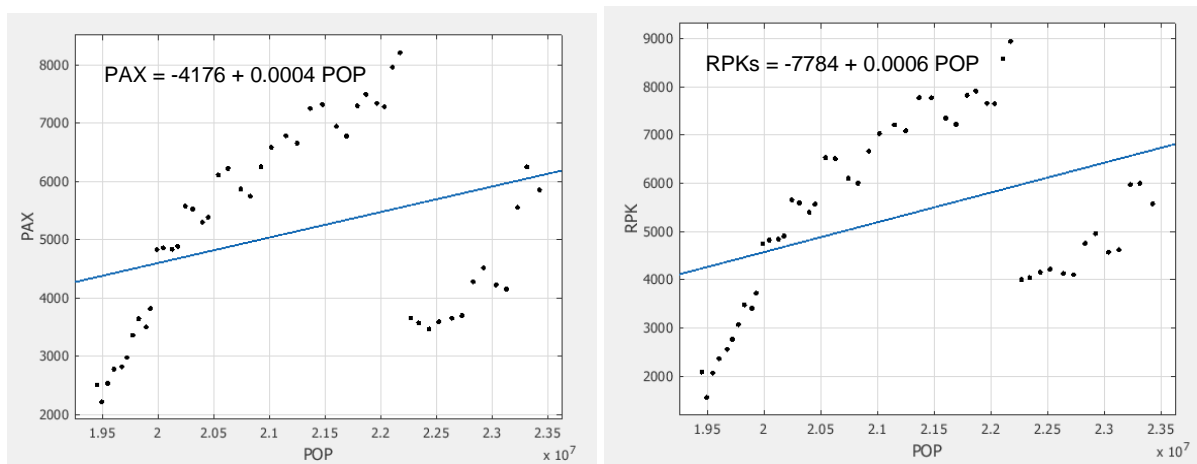


Figure 8.4. The relationship between Australia's population size and Australia's domestic LCC passenger demand

8.3.3 Australia's real GDP

There is an extensive body of literature that notes that real GDP is the major driving force of air travel demand, regardless of trip purpose (see, for example, Dempsey 2004; Doganis 2009; Janić 2011). Economic growth is regarded as the primary predictor of air travel demand: an increase in GDP normally entails more than proportional increase in airline traffic, and conversely, demand is extremely sensitive to economic recessions (Dempsey 2004). Australia's real GDP was included as a predictor variable in the study's genetic algorithm, artificial neural network (ANN), and artificial neuro-fuzzy inference system (ANFIS) PAX and RPKs models. The coefficient of Australia's real GDP was found to be 0.03 in both $GAPAXDE_{lin}$ and $GARPKSDE_{lin}$ model. Australia's real GDP was also shown to be an important predictor variable in the ANN models with the contribution value of 4.42 and 4.59 in the PAX and RPKs model, respectively. The ANN and ANFIS models were tested with and without Australia's real GDP as a predictor variable. In these modelling approaches, both the PAX and RPKs models were found to be more accurate and reliable, and provided a greater forecasting capability when Australia's real GDP was included as a predictor variable in the models.

The findings are similar to those of Aderamo (2010), Alekseev and Seixas (2009) and Sivrikaya & Tunç (2013), who found that real GDP is a major predictor of domestic air travel demand.

In order to demonstrate the importance of the relationship between Australia's real GDP and the Australia's domestic LCC passenger demand (both enplaned passengers and RPKs), the data are plotted in Figure 8.5.

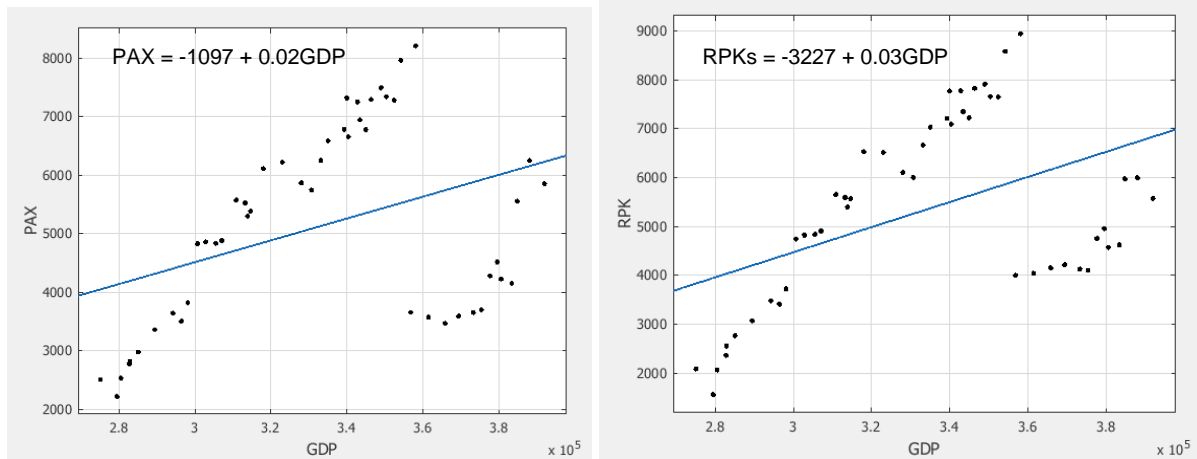


Figure 8.5. The relationship between Australia's real GDP and Australia's domestic LCC passenger demand

8.3.4 Australia's real GDP per capita

Non-business related air travel tends to be discretionary in nature and is paid from disposable income. Higher levels of income are often associated with greater disposable income and, thus, more non-business related trips by air (McKnight 2010). Historically, leisure travel has shown a strong response to personal income levels. Two things tend to occur as an individual personal income rises. First, they spend more on non-essential items. These often include expenditure on travel by all modes. Second, air travel, which has a higher cost is considered a more comfortable and convenient transport mode for longer journeys, becomes more competitive against surface transport modes and there is a shift of demand from surface transport modes to air. In other words, increases in income result in higher levels of expenditure by individuals on leisure travel, and at the same time a higher proportion of that expenditure is devoted to travel by air rather than by surface modes (Doganis 2009).

In order to model the influence of income as a predictor of Australia's domestic LCC passenger demand, two income measures were used in the study – Australia's real GDP and Australia's real GDP per capita. As we have just noted in Section 8.3.3, Australia's real GDP was found to be a more significant predictor variable in the study's genetic algorithm, artificial neural network (ANN), and adaptive neuro fuzzy inference system (ANFIS) PAX and

RPKs models than Australia's real GDP per capita. However, in the case of the traditional multiple linear regression PAX and RPKs MLR modelling, Australia's real GDP per capita was found to be more statistically significant. The coefficient is 1.94 in MLR PAX model and 2.39 in MLR RPKs model.

Figure 8.6 shows the importance of the relationship between Australia's real GDP per capita and the Australia's domestic LCC passenger demand (both enplaned passengers and RPKs).

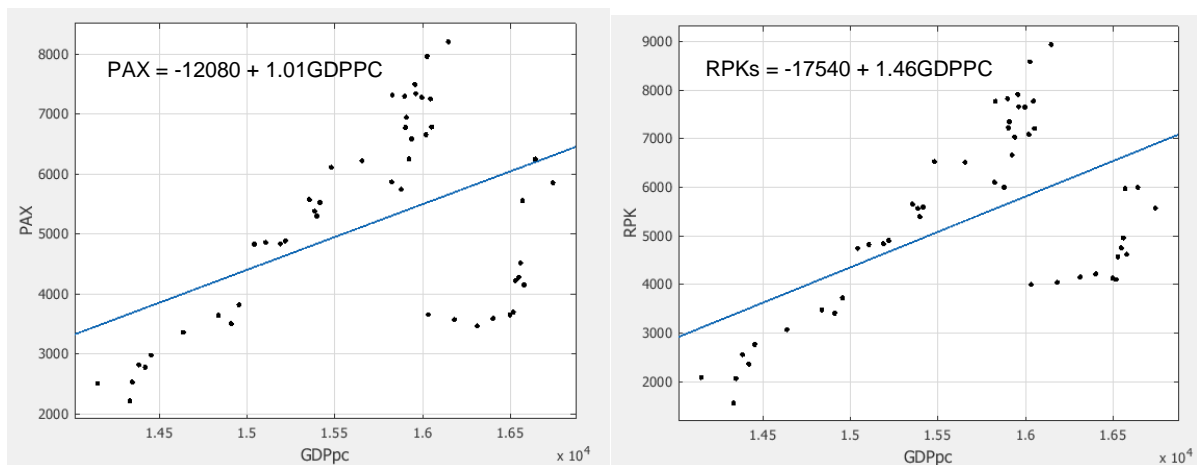


Figure 8.6. The relationship between Australia's real GDP per capita and Australia's domestic LCC passenger demand

The finding that Australia's real GDP per capita is a driver of Australia's domestic LCC passenger demand supports the views of the literature that GDP per capita is, in fact, an important predictor of air travel demand (Doganis 2009; Love et al. 2006).

8.3.5 Australia's unemployment size

As we have previously noted, employment also influences air travel demand (Doganis 2009). *Ceterus paribus*, rising levels of employment tend to positively influence air travel demand, while increasing levels of unemployment tend to dampen or depress air travel demand (McKnight 2010). This occurs because there are significant economic effects associated with employment. The standard of living of certain demographic groups and individuals will be affected by changes in the incidence of a country's employment and unemployment rate (Martin 1991). Job losses result in a significant decline in income and hence consumption for individuals and their families. Job losses also have a "snow-ball" effect as the reduction in

expenditure by families experiencing loss of jobs means further loss of demand for businesses, resulting in further unemployment (Goolsbee 2010).

Australia's unemployment size was included as a predictor variable in the study's genetic algorithm, artificial neural network (ANN), and artificial neuro-fuzzy inference system (ANFIS) PAX and RPKs models. The coefficient of Australia's unemployment size was found to be (-12.33) in the $GAPAXDE_{in}$ model, and (-12.75) in the $GARPKSDE_{in}$ model, respectively. Australia's unemployment size was also shown to be an important predictor variable in the ANN models with the contribution value of 4.07 and 5.42 in the PAX and RPKs model, respectively. The ANFIS models were also tested with and without Australia's unemployment size as a predictor variable. In the ANFIS modelling approach, both the PAX and RPKs models were found to be more accurate and reliable, and provided a greater forecasting capability when Australia's unemployment size was included as a predictor variable. The modelling results therefore suggest that changes in Australia's unemployment size are a significant predictor of Australia's domestic LCC passenger demand.

Figure 8.7 shows the importance of the relationship between Australia's unemployment size and the Australia's domestic LCC passenger demand (both enplaned passengers and RPKs).

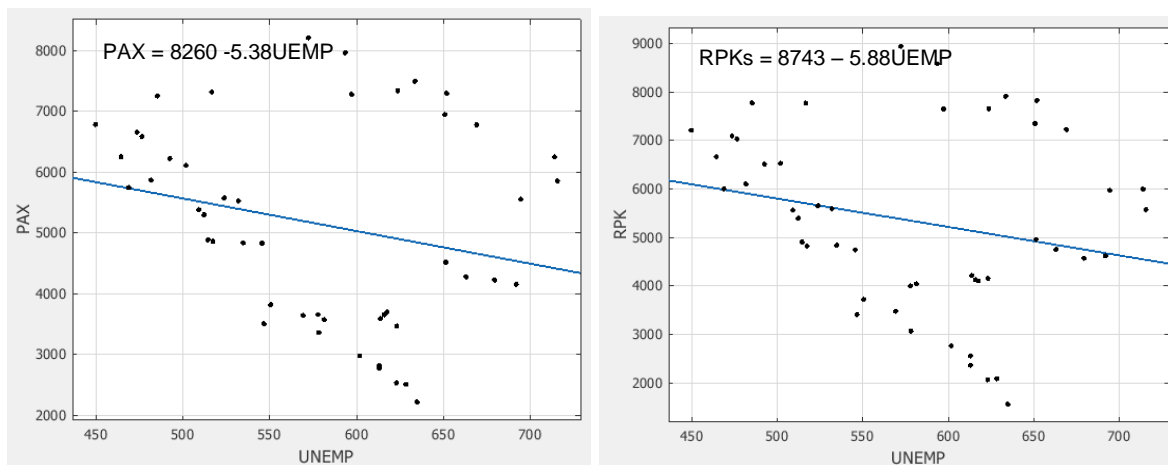


Figure 8.7. The relationship between Australia's unemployment size and Australia's domestic LCC passenger demand

8.3.6 World jet fuel prices

Oil prices are quite often viewed as a key indicator of travel costs, particularly for air travel (Li 2010). Indeed, sharp increases in world oil prices have had significant (though often

temporary) effects on air travel demand (Penner 1999). This is because an increase in oil prices results in higher travel costs. The higher travel costs subsequently results in leisure travel, the primary focus of Australia's domestic LCC, being more expensive (Li 2010).

As can be observed in Table 8.5, world jet fuel prices were included as a predictor variable in all four modelling approaches (MLR, GA, ANN, ANFIS). The coefficient of world jet fuel prices was found to be (620.68) in the MLR PAX and (632.05) in the RPKs models, and (683.16) in the $GAPAXDE_{lin}$ model, and (660.25) in the $GARPKSDE_{lin}$ model, respectively. World jet fuel prices was also shown to be an important predictor variable in the ANN models with the contribution value of 4.97 and 3.73 in the PAX and RPKs model, respectively.

It is expected that relationship between fuel price and air travel demand will be negative since an increase in fuel prices, leads to higher air travel costs and therefore make leisure travel dearer (Li 2010). However, in this study the coefficient of jet fuel price was found to be positive. According to Morrell and Swan (2006), oil prices sometimes can move with air travel demand, that is, when the economy grows fast, demand for oil increases since oil is essential to grow the economy. And when the economy is growing, consumer confidence is escalating, causing air travel demand to increase.

The ANFIS models were tested with and without world jet fuel prices as a predictor variable. In this modelling approach, both the PAX and RPKs models were found to be more accurate and reliable, and provided a greater forecasting capability when world jet fuel prices were included as a predictor variable.

8.3.7 Australia's real interest rates

As we noted in Chapter 4, short-term conditions such as official interest rates can have a strong influence on the growth potential of both individual airlines and the total industry (Abed et al. 2001). This is because interest rates influence the balance between expenditure and saving (Cook 2007). If interest rates decline, this may influence demand for goods and services. This is because many homeowners have a mortgage and the falling interest rate will increase their discretionary income. This is the income that they have available to purchase non-necessities. Hence, they will purchase more of most normal goods and services (Wilkinson 2005). Furthermore, high interest rates will inhibit economic activity, which can have a dampening effect on airline traffic (Wensveen 2011).

As can be seen in Table 8.5, Australia's real interest rates were included as predictor variables in all four modelling approaches (MLR, GA, ANN, ANFIS). The coefficient of Australia's real interest rates was found to be (-212.58) in the MLR PAX and (-198.26) in the RPKs models, and (-720.25) in the $GAPAXDE_{in}$ model, and (-684.66) in the $GARPKSDE_{in}$ model, respectively. Australia's real interest rates was also shown to be an important predictor variable in the ANN models with the contribution value of 3.75 and 4.48 in the PAX and RPKs model, respectively. The ANFIS models were tested with and without Australia's real interest rates as a predictor variable. In this modelling approach, both the PAX and RPKs models were found to be more accurate and reliable, and provided a greater forecasting capability when Australia's real interest rates were included as a predictor variable. A similar situation occurred with the genetic algorithm models, which were also tested with Australia's real interest rates included and not included as a predictor variable.

Based on these findings it can be concluded that Australia's real interest rates do act as a predictor of Australia's domestic LCC passenger demand. This finding therefore supports the views of Abed et al. (2001) and Cook (2007) who have suggested that interest rates act as a predictor of air travel demand. This is also an important finding, as it is to the best of the author's knowledge, the first time that real interest rates have been included as a predictor variable in air travel demand forecasting models. The study findings therefore provide a new insight into the importance of Australia's real interest rates as a predictor of Australia's domestic LCC passenger demand.

Figure 8.8 shows the importance of the relationship between Australia's real interest rates and the Australia's domestic LCC passenger demand (both enplaned passengers and RPKs).

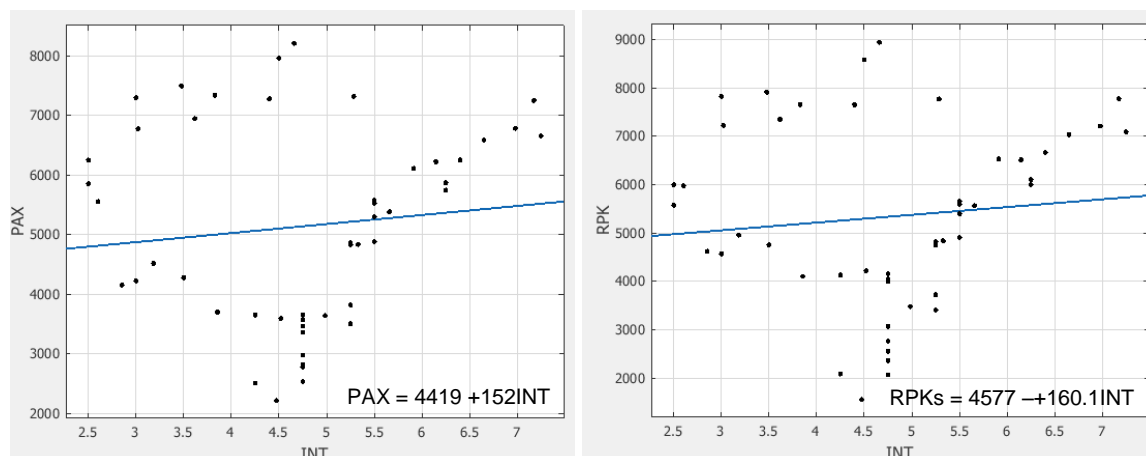


Figure 8.8. The relationship between Australia's real interest rates and Australia's domestic LCC passenger demand

8.3.8 Recorded bed capacities at Australia's tourist accommodation

Low cost carriers (LCCs) have become an integral part of today's tourism and air transport industries. Air transport and tourism are natural complements – for many tourist trips, air travel is the preferred transport mode and for some trips, it is the only transport means available. In addition, lower air fares result in more tourists as customers of the tourism industry, and lower ground costs induce more tourists to utilise the services of airlines. The LCCs have become extremely important as they are having significant impacts on tourism. Most LCCs are oriented towards the leisure travel market segment, though some also attempt to attract price conscious business travellers. The most pronounced impact LCCs have is on the size of the overall market. Indeed, the lower air fares offered by LCCs leads to more travel, though some travel may be at the expense of the surface modes. Furthermore, the products and services offered by LCCs are changing tourism markets. The ready available of cheap, and in some instances very low, air fares makes air travel trips of a short duration feasible. In addition, LCCs are having a further important impact on the development of secondary destinations. Holiday makers are increasingly discovering the attractions of destinations which were less well known, and in some cases less crowded. Such destinations have realised the importance of the LCCs generating new tourism demand for their destinations, and in some instances they have been offering financial inducements to the LCCs to operate services. LCCs are therefore changing, as well as growing, tourism markets (Forsyth 2006).

Tourists also often use LCCs flights to take a short-break or short holidays (Macchiavelli & Cinesi 2006). Indeed, low-cost carriers are significant for the development of weekend, city or short-break tourism and are influencing the expansion of potential destinations (Graham & Shaw 2008). Visiting friends and relatives (VFR) traffic are also using LCCs as part of their travel plans (Bieger & Wittmer 2006). The LCCs are therefore extending the range of motivations and frequency of travel for private leisure (Olipra 2012).

An examination of the markets served by Australia's domestic low cost carrier shows that tourist destinations form a key part of their route network structure. For example, Tiger Airways currently serves Cairns, Coffs Harbour, Gold Coast, Mackay, and the Whitsunday Coast, all of which are key tourism destinations. Hence, due to the close relationship between LCCs and tourism, recorded bed capacities at Australia's tourist accommodation, was included as a proxy variable for tourism (Tsekeris 2009), in order to empirically examine the relationship between tourism and Australia's domestic LCC passenger demand.

The modelling results presented in Table 8.5, show that the tourism proxy variable was significant, and has been included as a predictor variable in the artificial neural network PAX and RPKs (ANN) models, the genetic algorithm GAPAXDE and GARPKSDE models, and the ANFIS PAX and RPKs models. The coefficient of Australia's tourism attractiveness was found to be 0.01 in both the GAPAXDE and GARPKSDE model, respectively. Australia's tourism attractiveness was also shown to be an important predictor variable in the ANN models with the contribution value of 5.82 and 8.16 in the PAX and RPKs model, respectively.

The ANN and ANFIS models were tested with and without Australia's tourism attractiveness as a predictor variable. In these modelling approaches, both the PAX and RPKs models were found to be more accurate and reliable, and provided a greater forecasting capability when Australia's tourism attractiveness were included as a predictor variable. The findings of the study therefore reveal that Australia's tourism attractiveness is indeed an important predictor of Australia's domestic LCC passenger demand. The findings are also consistent with other studies that have examined the influence of LCCs on domestic tourism demand (Bieger & Wittmer 2006; Chung & Wang 2011).

Figure 8.9 shows the importance of the relationship between Australia's tourism attractiveness and the Australia's domestic LCC passenger demand (both enplaned passengers and RPKs).

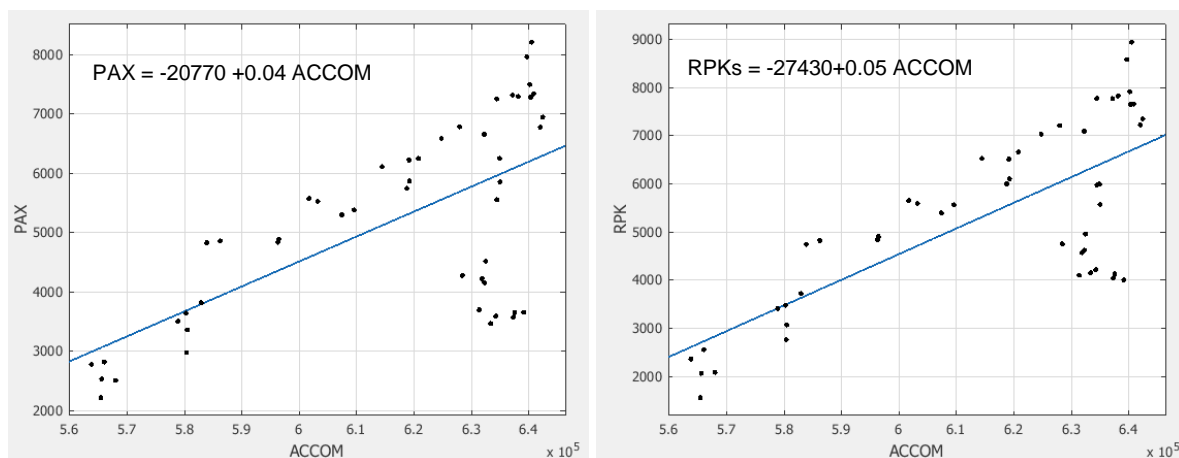


Figure 8.9. The relationship between Australia's tourism attractiveness and Australia's domestic LCC passenger demand

8.3.9 Summary of the principal predictors of Australia's domestic low cost carrier passenger demand

A key aim of this thesis was to examine: *What are the principal predictors of Australia's domestic LCC passenger demand?* In the preceding section it was shown that the primary predictors of Australia's domestic LCC passenger demand are Australia's real best discount airfare, Australia's population size, Australia's real GDP, Australia's real GDP per capita, Australia's unemployment size, world jet fuel prices, Australia's real interest rates, and recorded bed capacities at Australia's tourist accommodation. The socio economic variables comprise Australia's population size, Australia's real GDP, Australia's real GDP per capita, Australia's unemployment size, Australia's real interest rates, recorded bed capacities at Australia's tourist accommodation. The two principal air transport system variables influencing Australia's domestic LCC passenger demand are Australia's real best discount airfares and world jet fuel prices.

Importantly, this study sought to examine for the first time the influence of three new socio-economic factors - Australia's unemployment size, tourism attractiveness factor, and Australia's real interest rates – as predictors of Australia's domestic LCC passenger demand. Australia's real interest rates were included in all of the study's models, whereas Australia's unemployment size and tourism attractiveness factor, using recorded bed capacities at Australia's tourist accommodation as a proxy were included in all models except the MLR models due to this independent variable statistically insignificant relationship with the dependent variables (Australia's LCC explained passenger and RPKs). However,

the inclusion of Australia's real interest rates as a predictor variable in the GA, ANN and ANFIS model improved these model's accuracy, reliability, and predictive capability. It can therefore be concluded that Australia's unemployment size, tourism attractiveness factor, and Australia's real interest rates are, in fact, important predictors of Australia's domestic LCC passenger demand and are worthy of consideration in any future air travel demand forecasting studies.

The results of the independent variables used in MLR, GA, ANN and ANFIS for both PAX and RPKs models were summarised and presented in Table 8.5. It was noted that when modelling the MLR, GA, ANN and ANFIS models using two demand measurements, PAX and RPKs, the same set of independent variables were included in both PAX and RPKs models.

In the MLR PAX and RPKs models, 5 independent variables were found to be significant: Australia's real best discount airfare, Australia's real GDP per capita, Australia's real interest rates, world jet fuel prices and dummy variable reflecting Virgin Australia changing business model. While in the GA, ANN and ANFIS PAX and RPKs models, a total of eight independent variables were included in the models. These were Australia's real best discount airfare, Australia's population size, Australia's real GDP, Australia's unemployment size, world jet fuel prices, Australia's real interest rates, recorded bed capacities at Australia's tourist accommodation and three dummy variables reflecting Virgin Australia changing business model, the collapse of Ansett Australia, and the Commonwealth Games in 2006. The modelling results are plausible and support the findings in the literature and, very importantly for the first time, provide important insights for industry practitioners and key stakeholders into the principal predictors of Australia's domestic LCC passenger demand.

8.4 The Hybridization of Australia's Low Cost Carriers Business Models

Recall now that Koo (2009) has noted that there are numerous variations to the LCCs' business model. Indeed, as we saw in Chapter 3 (Section 3.4), it has been argued that the business models of many LCCs around the world have been evolving into what has been termed a '*hybrid*' model (Tomová & Ramajová 2014; Vidović et al. 2013). In light of the evolving LCCs' business models, and the trend towards a 'hybrid model', a further aim of this thesis was to investigate whether Australia's domestic LCC have also implemented a "hybrid" business model. In order to achieve this aim, the following research question was

proposed: *How have Australia's domestic low cost carriers business model followed that of other low cost carriers from around the world?*

A key finding of this thesis is that Australia's domestic LCC have indeed moved towards a hybrid business model. This has occurred from not long after Jetstar Airways was established in 2004. The analysis in Section 3.4 revealed that Australia's domestic LCC's business model has been hybridized as follows:

Product: Both Jetstar and Tiger Airways product attributes have become similar to those of full service network carriers. This is because both airlines have now embraced and offer frequent flyer programs (which is not a traditional LCC business model attribute). Jetstar offers a form of premium seating (first three rows of economy) on their domestic Australian services.

Fleet: Both Jetstar and Tiger Airways follow the typical LCC business model in regards to their Australian domestic fleet. Both of these airlines have selected the Airbus A320 as their preferred aircraft type. Jetstar also operates a small sub-fleet of six Airbus A321 aircraft on more dense routes in Australia. One of the unique features of Jetstar's hybridization has been its focus on both domestic Australian services, international services from Australia to key Asian and US leisure markets, as well as its Pan-Asian strategy. Consequently, the Jetstar Group has a heterogenous aircraft fleet structure, with the airline group fleet comprising Airbus A320, A321 and A330 as well as Boeing B787 aircraft (the latter two types are operated by Jetstar International). Also, an example of the hybridization of the Jetstar business model is that it offers "Star" or business class seats on its international services to and from Australia.

Route Network: Both Jetstar and Tiger Airways operate a point-to-point route network connecting Australia's major capital cities. Their route networks also focus on connecting Australia's major capital cities with key leisure and tourist markets. For example, both airlines focus heavily on serving key tourist destinations in Queensland, such as, the Gold Coast. Following the trend in other LCC markets around the world, Australia's LCC are also focusing on serving secondary tourist markets. This is evident by the operation of services by both LCCs to destinations, such as Ballina and Coffs Harbour in NSW, and the Whitsunday Coast in Queensland. In general terms, both Tiger and Jetstar Airways Australian operations utilize primary or major airports. An exception to this strategy is

Jetstar's use of Avalon Airport, located 55 kilometres from Melbourne, from which it provides 5 daily services each day to Sydney (Lannen 2014).

A further example of the hybridization of Jetstar's business model has been the airline's recent strategic alliance signed with Emirates Airline. A unique feature of this alliance is that Jetstar will be able to drive domestic tourism destinations through the additional feed of traffic from Emirates vast global route network. Jetstar also has code-sharing arrangements with other airlines (primarily full service network carriers), who are members of the oneworld strategic airline global alliance. Traditionally, LCCs have not embraced strategic alliances or code-sharing arrangements with other full service network carriers (FSNCs).

Pricing and distribution channels: Throughout the history of their operations in Australia, both Jetstar and Tiger Airways have adopted a dynamic air fare pricing strategy, with large discounts often being offered to stimulate demand. Virgin Blue, when it was an LCC, followed a similar strategy. This suggests that both Jetstar and Tiger are following the pricing attribute of the traditional LCC business model. However, both airlines offer a simplified pricing structure with deeply discounted fare levels available for customers that book flights early. In contrast, later booking customs often pay higher air fares. This suggests that both airlines use a price discrimination strategy (Belobaba 2009), and are mindful of customer's willingness-to-pay (WTP).

In recent times, both airlines have moved away from the traditional LCC business model that did not embrace the use of global distribution systems (GDSs) and travel agents, due to their high costs, to one, where both airlines are now members of GDS, and Jetstar actively pursue business from travel agents. Notwithstanding, both airlines also encourage passengers to book directly with them via their website. This is a cost and customer service-related strategy.

Focus on ancillary revenue streams: Historically, the traditional LCC business model has placed a very high focus on the generation of ancillary revenues. The analysis of Australia's domestic LCC market presented in Section 3.4, found that Jetstar, throughout its history, has also implemented strategies to capture ancillary revenues, from such areas as in-flight meal charges, and rental fees for the use of in-flight entertainment equipment (IFE).

Tiger Airways also earns revenue from a diverse range of sources, including fees for bookings made by the internet and by travel agents, excess baggage charges, sporting

baggage charges, booking amendment charges, and preferred selected seat charges (Tiger Airways Holdings 2014b).

8.5 Summary

This chapter has presented the study's empirical results. It was shown that there are multiple forecasting approaches available to airline management to forecast passenger demand. In addition to the traditional multiple linear regression (MLR) approach, genetic algorithm, artificial neural networks (ANNs), and the adaptive neuro-fuzzy inference system (ANFIS) approaches, the latter three based on artificial intelligence methods, are available for this critical airline management function. The study results showed that the adaptive neuro-fuzzy inference system (ANFIS) approach was the most accurate and reliable model, and provided the most predictive capability in forecasting Australia's domestic LCC passenger demand.

The chapter also discussed the primary predictors of Australia's domestic LCC passenger demand. It was shown that these primary predictors are Australia's real best discount airfare, Australia's population size, Australia's real GDP, Australia's real GDP per capita, Australia's unemployment size, world jet fuel prices, Australia's real interest rates, and recorded bed capacities at Australia's tourist accommodation. The socio-economic variables comprise Australia's population size, Australia's real GDP, Australia's real GDP per capita, Australia's unemployment size, Australia's real interest rates, recorded bed capacities at Australia's tourist accommodation. The two principal air transport system variables influencing Australia's domestic LCC passenger demand are Australia's real best discount airfares and world jet fuel prices.

Finally, the chapter discussed the hybridization strategies that Australia's domestic LCC have defined and implemented in response to the changing market requirements. These strategies are very similar to those of other LCCs based in other parts of the world.

The following chapter presents the study's concluding remarks, highlights the limitations of the study, discusses the significance of the research undertaken, and offers suggestions for future research.

CHAPTER NINE: CONCLUDING COMMENTS

9.1 Overview

Due to the vast size of the Australian continent, the country's varied and rugged topography and scattered population present significant transport challenges (Nolan 1996). Australia's LCC have responded to this challenge since their inception in 2000. Starting from relative humble beginnings with Virgin Blue's initial operations, Australia's LCC have since achieved considerable market success. Indeed, since the deregulation of Australia's domestic airline market in 1990, the LCCs market segment has also displayed strong growth, peaking in 2010 with a 57 per cent market share, and is now around 31 per cent. The decline in the size of this market segment since 2011 can largely be attributed to the change in business model of Virgin Australia, who, as we have noted throughout this thesis, has moved from a more traditional LCCs to FSNCs business model since 2011.

In order to satisfy the dynamic changes in airline passenger demand as well as optimise aircraft utilisation and revenues, LCCs require highly accurate and reliable passenger demand forecasts. Also, in defining and implementing strategies, it is a critical requirement for airline management to be cognizant of the factors that shape not only passenger demand, but also the market environment in which they compete. As has been argued throughout this thesis, the factors that influence passenger demand are varied in nature, and may have a positive or negative influence on traffic demand. Therefore, when defining and implementing a business model and competitive strategies, Australia's LCC require models that will enable them to forecast their passenger traffic with the highest possible degree of accuracy. They will also need to be mindful of the factors that will influence passenger demand and their competitive strategies. With this in mind, this thesis has sought to identify and empirically examine the most accurate and reliable forecasting methods, as well as to obtain key insights into the factors that will either positively or negatively influence Australia's LCC passenger demand. This was the general aim of this thesis.

This thesis has four key aims. These are restated below:

- Empirically examine the International Civil Aviation Organization recommended econometric passenger forecasting modelling approach with the artificial intelligence-based forecasting methods in order to determine the optimum method for forecasting Australia's LCC demand.

- Empirically examine whether artificial intelligence-based forecasting models provide more accurate and reliable Australia's LCC passenger demand forecasts as compared to the traditional multiple linear regression approach.
- Explore the principal predictors of Australia's domestic LCC passenger demand.
- Investigate whether Australia's domestic LCC have adopted a hybrid business model similar to other LCCs located around the world.

This concluding chapter is structured as follows. Section 9.2 explains the requirement for the research. Section 9.3 discusses how the research will be useful for key industry stakeholders and academics. This is followed by the study approach (Section 9.4), and a comment on the modelling results (Section 9.5). Section 9.6 summarizes the research outcome. Section 9.7 highlights the study's methodological and theoretical contributions. Section 9.8 identifies and explains the limitations of the study and offers suggestions for future research.

9.2 The Requirement for Basic Research

Irrespective of the business model defined and implemented by an airline, this thesis has argued that forecasting passenger demand is a most critical requirement for airline management. Indeed, as Doganis (2009) observes forecasting is considered the most critical area of airline management. The importance of forecasting air travel demand for airline executives is as follows:

- Demand forecasting is essential when planning and scaling capital investment and infrastructure, and when scaling air transport related firms (Fernandes & Pacheco 2010).
- In order to plan the supply of services that is necessary for an airline to satisfy that demand (Doganis 2009).
- Forecasting passenger transport demand is of critical importance for airlines as well as for investors since investment efficiency is greatly influenced by the accuracy and adequacy of the estimation performed (Blinova 2007).
- Air traffic forecasts are also one of the key inputs into airlines' fleet planning, route network development, and they are also used in the preparation of airline's annual operating plans (Ba-Fail et al. 2000).

The literature on airline passenger demand forecasting is extremely extensive and, as reported in Chapter 2, has attracted considerable research attention since 1950, and especially since 2001. However, there is a surprising lack of research focussing on the development and empirical testing of the traditional multiple linear regression (MLR) and artificial intelligence-based methods to forecast Australia's LCC passenger demand. Further, there have been no reported studies that have proposed and empirically tested models for forecasting Australia's domestic LCC passenger demand – a critical research area in its own right. The optimum modelling method, in terms of accuracy, reliability, and predictive capability, for forecasting Australia's domestic LCC passenger demand is therefore not readily identifiable. Based on the critical importance of forecasting for airline management the key aim of this thesis was to address this apparent gap in the literature. Indeed, the lack of previous research in this area was a key motivation for this study.

Furthermore, the factors that influence air travel demand are complex (Doganis 2009; Vasigh et al. 2008). Each factor is composed of elements that can stimulate or reduce air travel demand. The comprehensive review of the extant literature on airline passenger demand forecasting revealed that in addition to income measures (real GDP or real GDP per capita), cost (air fare), that there are other socio-economic factors, for example, unemployment and real interest rates, which may stimulate or reduce demand. In the absence of any studies that have proposed and empirically examined models for forecasting Australia's domestic LCC passenger demand, it was not clear what the primary predictors of Australia's domestic LCC passenger demand actually are. Nor has there been any reported research into the influence of Australia's unemployment, real interest rates, and tourism attractiveness on Australia's domestic LCC passenger demand. Thus, a secondary aim of this research was to achieve a greater understanding of the factors which influence in Australia's domestic LCC passenger demand. This investigation also sought to identify whether Australia's unemployment, tourism attractiveness, and real interest rates are significant predictors of Australia's domestic LCC passenger demand.

In addition, the LCC industry has been evolving around the world in response to changing customer requirements. This has led to new type of business model, which has been termed a '*hybrid*' model (Tomová & Ramajová 2014; Vidović et al. 2013). In light of the evolving LCC business models, and the trend towards a '*hybrid model*', a further aim of this thesis was to explore whether this strategy has been adopted by Australia's domestic LCC as well.

9.3 To whom is this Research Useful?

Knowledge of the critical predictors of Australia's LCC passenger demand together with new, more accurate, and reliable forecasting models can assist LCC executives in more precisely forecasting their passenger demand. Also, the choice of new more powerful, and accurate and reliable, passenger demand forecasting models may be of considerable assistance to government agencies, aviation consultancy organisations, and industry bodies, who have an interest in forecasting future air travel demand. Airport managers could also benefit from the results of this study as forecasting is a critical part of the airport master planning process. From an academic perspective, the modelling results of this thesis provide new insights into LCC passenger demand forecasting methods and, it is hoped, that they will facilitate future additional research into this critical area.

9.4 The Study Approach

The study commenced with a comprehensive survey of the airline management, transportation, and economics literature as well as government reports that have focused on air travel demand modelling. The objective of this task was to review the air travel demand modelling approaches that have been undertaken over the period 1950 to 2014. An additional objective was to identify any previous studies that have focused on forecasting LCC passenger demand, both globally, and, most importantly in the context of this thesis, in Australia. The survey revealed that by far the most predominant air travel demand forecasting method was the traditional multiple linear regression (MLR) method. Interestingly, this is also the recommended passenger forecasting approach of the International Civil Aviation Organization (ICAO), the world's peak air transport body.

Once the previous air travel demand modelling approaches were identified, a review of the economics and statistics/forecasting journals was then conducted in order to identify any new contemporary modelling approaches that could potentially be used for airline passenger air travelling demand forecasting was undertaken. Two such methods identified were the genetic algorithm and adaptive neuro-fuzzy inference system (ANFIS) approaches. The literature survey also revealed that there has been very limited use of artificial neural networks (ANNs) for forecasting airline passenger demand.

Based on this approach there was strong justification for testing the traditional or classical linear regression (MLR) forecasting approaches with the artificial intelligence-based

forecasting methods identified from the comprehensive literature survey. As noted earlier, the artificial intelligence-based approaches for forecasting air travel demand have attracted surprisingly limited research focus in the literature. A total of three studies have proposed and tested artificial neural networks in the context of air travel demand forecasting (Alekseev & Seixas 2002, 2009; Blinova 2007). Moreover, there have been no reported studies that have proposed and empirically tested genetic algorithm or artificial neuro-fuzzy inference system (ANFIS) LCC passenger demand forecasting models.

The predictors of air travel demand were also investigated in the literature survey. Specifically, this survey sought to identify any previous studies that had developed and tested models for forecasting LCC demand, so as to ascertain the independent variables included in the modelling. Surprisingly, no such studies were found. The literature survey revealed a range of socio-economic and air transport system factors that have been identified as predictors of air travel demand. Based on these insights, the data for the variables included in the modelling was collected.

The data on Australia's domestic LCC enplaned passengers and revenue passenger kilometres performed (RPKs) as well as key socio-economic data relating to the key predictors of Australia's domestic LCC passenger demand was collected from various sources and provided the empirical basis for the exploratory investigation. The important predictors of Australia's domestic LCC passenger demand were subsequently modelled using four modelling approaches (multiple linear regression, artificial neural network, genetic algorithm and adaptive neuro-fuzzy inference system). Each of the modelling approaches were evaluated using up to five goodness-of-fit measures: mean absolute error (MAE), mean absolute percentage error (MAPE), mean square error (MSE), root mean square error (RMSE), and correlation coefficient (R). The results of the modelling are extremely plausible. We comment on the findings in the following section.

Finally, following the approach of Bowen (2009), a comprehensive document search was undertaken to investigate whether Australia's domestic LCC have adopted a hybrid business model similar to other LCCs located around the world

9.5 A Comment on the Modelling Results

The modelling techniques presented in this thesis are new and novel and should assist Australia's LCC executives in forecasting their passenger demand, both in terms of enplaned passengers, and revenue passenger kilometres performed (RPKs). To this author's knowledge, only Alekseev & Seixas (2002, 2009) and Blinova (2007) have used artificial neural networks (ANNs) to forecast domestic passenger air travel demand. There have been no reported studies proposing either genetic algorithm or adaptive neuro-fuzzy inference systems (ANFIS) models for forecasting Australia's domestic LCC passenger demand. The results have demonstrated that it is possible and indeed plausible to use artificial neural networks (ANNs), genetic algorithm, and ANFIS models to forecast Australia's domestic LCC passenger demand. These artificial intelligence-based approaches have been shown to provide more accurate and reliable results when compared to the multiple linear regression models. This is the most important finding as it highlights the value of artificial intelligence methods. Thus, the International Civil Aviation Organization and other key industry stakeholders involved with forecasting passenger demand could therefore consider the use of such methods rather than the traditional multiple linear regression method.

Of the three artificial intelligence-based methods used in the study, the new, and novel, ANFIS PAX and RPKS models were shown to be the most accurate and reliable of the modelling approaches undertaken in thesis, in terms of accuracy, reliability, and predictive capability, and measured by the following goodness-of-fit measures: MAE, MAPE, MSE, and RMSE.

PAX Model: MAE = 213.0, MAPE = 4.36 per cent, MSE = 7.1×10^4 , and RMSE = 267.52.

RPKs Model: MAE = 218.97, MAPE = 5.55 per cent, MSE = 8.2×10^4 , and RMSE = 286.81.

In the multiple linear regression (MLR) PAX and RPKs models, 5 independent variables were found to be significant: Australia's real best discount airfare, Australia's real GDP per capita, Australia's real interest rates, world jet fuel prices, and dummy variable reflecting Virgin Australia changing business. In the Genetic Algorithm (GA) $GAPAXDE_{quad}$ and $GARPKsDE_{quad}$ models, a total of 9 independent variables were included in the models: Australia's real best discount airfare, Australia's population size, Australia's real GDP, Australia's unemployment size, Australia's real interest rates, world jet fuel prices, recorded

bed capacities at Australia's tourist accommodation, two dummy variables reflecting Virgin Australia changing business model, and the Commonwealth Games in 2006. While in the ANN and ANFIS PAX and RPKs models, a total of 8 independent variables were included in the models. These were Australia's real best discount airfare, Australia's population size, Australia's real GDP, Australia's unemployment size, Australia's real interest rates, world jet fuel prices, and one dummy variable reflecting Virgin Australia changing business model. The modelling results are plausible and support the findings in the literature and, very importantly for the first time, provide important insights for industry practitioners and key stakeholders as to what are the principal predictors of Australia's domestic LCC passenger demand.

9.6 Research outcomes

The key aim of this thesis was to specify and empirically examine three artificial intelligence-based approaches (ANNs, GA and ANFIS) as well as the multiple linear regression approach, in order to identify the optimum model for forecasting Australia's LCC passenger demand. The core outcome of this research, the fact that modelling based on artificial neural network is far more effective than the traditional linear models prescribed by the International Civil Aviation Organization (ICAO), means that future work is essential to validate this.

Four research questions are addressed and the key findings are summarised as following;

What forecasting methods are available for estimating Australia's domestic low cost carrier passenger demand and how do they differ in applicability and capability?

The thesis commenced with an in-depth examination of the forecasting methods that have previously been used in air travel demand forecasting. This comprehensive survey of the literature provided valuable insights into the traditional air travel demand forecasting methods, the most popular method being multiple linear regression models. The survey of the literature also identified new, and novel, artificial intelligence-based forecasting methods that could be used to forecast Australia's domestic LCC passenger demand. Consequently, four forecasting approaches were identified from the literature survey. This study therefore used a classical multiple linear regression (MLR), artificial neural network (ANNs), genetic algorithm (GA), and the adaptive neuro fuzzy inference system (ANFIS) model to forecast Australia's domestic LCC passenger demand. Two measures of Australia's domestic LCC

passenger demand were used in the study. The first measure was the number of Australia's domestic LCC enplaned passengers (PAX). The second measure was Australia's domestic LCC revenue passenger kilometres performed (RPKs) (Belobaba 2009; Holloway 2008). The thesis highlighted the fact that there are multiple forecasting methods available to airline management to forecast passenger demand. Importantly, the modelling results showed that these modelling approaches do differ in applicability and capability. The artificial neuro-fuzzy inference system (ANFIS) method proved to have the most predictive capability, accuracy and reliability based on the goodness of fit measures (MAE, MAPE, MSE, RMSE).

How do artificial intelligence-based forecasting models perform in terms of accuracy and reliability in low cost carrier passenger demand forecasting as compared to the traditional multiple linear regression approach?

The three artificial intelligence-based forecasted approaches tested in this study were clearly shown to provide more accurate and reliable LCC passenger demand forecasts. The modelling results of all three artificial intelligence-based methods were therefore superior when compared to the traditional multiple linear regression approach. This suggests that artificial intelligence-based forecasting methods provide more accurate and reliable forecasts in Australia's domestic LCC passenger demand.

What are the principal predictors of Australia's domestic LCC passenger demand?

The results conclude that the principal *predictors* of Australia's domestic LCC passenger demand comprise of the socio economic variables including; Australia's population size, Australia's real GDP, Australia's real GDP per capita, Australia's unemployment size, Australia's real interest rates, recorded bed capacities at Australia's tourist accommodation. And the two principal air transport system variables influencing Australia's domestic LCC passenger demand are Australia's real best discount airfares and world jet fuel prices.

Importantly, this study sought to examine for the first time the influence of three new socio-economic factors - Australia's unemployment size, tourism attractiveness factor, and Australia's real interest rates – as predictors of Australia's domestic LCC passenger demand. Australia's real interest rates were included in all of the study's models, whereas Australia's unemployment size and tourism attractiveness factor, using recorded bed capacities at Australia's tourist accommodation as a proxy were included in all models except the MLR models due to this independent variable statistically insignificant relationship

with the dependent variables (Australia's LCC enplaned passenger and RPKs). The inclusion of Australia's real interest rates as a predictor variable in the MLR, GA, ANN and ANFIS model improved these model's accuracy, reliability, and predictive capability. This is also an important finding, as it is to the best of the author's knowledge, the first time that real interest rates have been included as a predictor variable in air travel demand forecasting models. It can be concluded that Australia's unemployment size, tourism attractiveness factor, and Australia's real interest rates are, in fact, important predictors of Australia's domestic LCC passenger demand and are worthy of consideration in any future air travel demand forecasting studies.

How have Australia's domestic low cost carriers business model followed that of other low cost carriers from around the world?

This thesis revealed that Australia's domestic LCC have indeed moved towards a hybrid business model. This has occurred from not long after Jetstar Airways was established in 2004. Jetstar Airways has enhanced its product offering to include frequent flyer arrangements and inter-airline pricing and code-sharing agreements – product attributes normally eschewed by LCCs. In a highly innovative and indeed unique strategy, Tiger Airways Australia has developed an infrequent flyer program – a world first, further confirming the hybridization of Australia's domestic LCC's business models

9.7 Overall Contribution to Knowledge of the Study

9.7.1 Air travel demand forecasting methodological contribution

The major contribution of this thesis is the advancement in the forecasting approaches and models that have been developed and tested for forecasting Australia's LCC passenger demand. The genetic algorithm and artificial neuro-fuzzy inference systems (ANFIS) approaches are, in fact, new and novel modelling paradigms, and for the first time, these approaches have been applied for forecasting Australia's domestic LCC passenger demand. In fact, this is also the first reported study that has used genetic algorithm and ANFIS models for forecasting airline passenger demand.

The models have been shown to be more accurate, reliable, and have greater predictive capability as compared to the traditional multiple linear regression models (MLR), which are

the recommended approach of the International Civil Aviation Organization and other key government agencies around the world.

9.7.2 Theoretical contribution

As highlighted throughout this thesis, the factors that influence air travel demand are complex in nature. The comprehensive literature survey revealed a range of socio-economic and air transport system that have been postulated as influencing air travel demand. One of these factors was real interest rates (Cook 2007; Wensveen 2011). This study was the first to examine real interest rates as a predictor of air travel demand (not just Australia's domestic LCC passenger demand). This thesis therefore makes an original contribution by establishing and empirically proving the link between Australia's real interest rates and the development of Australia's domestic LCC passenger demand model.

The literature review also identified unemployment as a predictor of air travel demand. Despite this there has been no other study that has examined the influence of Australia's unemployment size on Australia's domestic LCC passenger demand (nor Australia's domestic or international air travel markets, as well). Unemployment was found to be an important predictor of Australia's domestic LCC passenger demand – being an independent variable in all four modelling approaches. This result confirms that changes in Australia's unemployment size can influence the demand for Australia's domestic LCC passenger demand. This finding provides a valuable insight into the importance of this relationship between Australia's unemployment size and Australia's domestic LCC passenger demand.

Air transport and tourism have a very strong association. As noted in Chapter 4, Australia, as is the case with most developed economies, tourism industry is heavily oriented towards domestic expenditure by Australian residents (Hooper & van Zyl 2011). Domestic tourism accounts for three-quarters of tourism expenditure in Australia, with the balance accounted for by international tourists spending (OECD 2014). Australia's domestic LCC have placed a very high strategic focus on serving Australia's key tourist markets, particularly those in Queensland and Northern NSW. Thus, a further important finding of this study was that tourism attractiveness, not surprisingly, is a significant predictor of Australia's domestic LCC passenger demand. This is an important finding and provides a greater understanding of the importance of the relationship between Australia's domestic LCC and the tourism sector, a research area not previously examined in the context of Australia.

A further contribution of this thesis relates to the growing literature on the hybridization of the LCCs business models. Historically, the LCCs have eschewed strategic airlines with full service network carriers. An important finding arising from Section 3.4 on the hybridization of Australia's LCC business models is that Jetstar has strategically aligned itself with full service network carriers (FSNCs). The airline has consummated direct alliance arrangements with Emirates, a major global FSNC, as well as similar agreements with oneworld strategic alliance members. This is a new contribution to the literature.

Tomová and Ramajová (2014) have reported that LCC's are, as part of their hybridization strategies, embracing loyalty programs (FFPs) as a key part of their service offering. This study found that Jetstar has followed this strategy, and has an agreement in place with Qantas Airways, where Jetstar passengers receive Qantas frequent flyer points. However, in a very novel approach, Tiger Airways Australia has introduced an "*in-frequent*" flyer program. Thus, this thesis extends the current understanding of airline frequent flyer programs by not only confirming Australia's LCC frequent flyer program approaches confirm the views of Tomová and Ramajová (2014), but also showing that "in-frequent" flyer programs are now a new LCC customer relationship management (CRM) strategy.

9.8 Study Limitations and Suggestions for Further Research

9.8.1 Data limitations

Australia's LCC market segment has only developed over the period 2000-2014. One of the limitations of the current study, therefore, was that the data used in the modelling was restricted to this time period. As mentioned in Section 4.2, a further limitation of the study was that neither Australian Government agency nor Department collects the data for the actual number of domestic and/or international tourists carried on Australia's LCC domestic services. Should this data become available in the public domain in the future, then possible future research could use both the actual domestic or international tourists travelling on Australia's domestic LCC, in forecasting Australia's domestic LCC passenger demand models.

9.8.2 Suggestions for future research

The core outcome of this research, the fact that modelling based on artificial intelligence approaches is far more effective than the traditional linear models prescribed by ICAO, means that future work is essential to validate this. Future work will look at overcoming the main limitation of this work, the limited data set size. That is, the case study selected for this work, LCCs in Australia, can be changed to any other case around the world. A few suggested examples of this to be directly investigated as a follow up to this work includes regional air traffic in Australia, the total domestic traffic in Australia, and Australia's international cargo demand.

The transferability of the methods investigated (ANN, GA and ANFIS), does not mean the data will be limited to Australia, or to passenger demand. With suitably sourced data, the methods utilised could be applied to any aviation data, including in the airport master planning process, in which forecasts are a vital as they enable airports to project and plan future demand for airside and landside infrastructure. The approach could also be easily adopted to government bodies, to assist with a variety of future planning considerations. This could include staffing for different services and facilities, as well as tourism demand, just to name a few.

With regards to the explicit case study of LCCs in Australia, as more data becomes available passengers and RPKs, it will become possible to use more data to obtain more robust modelling results, and to confirm the predictive ability of the models. This study has highlighted the requirement for basic research into the optimum models for forecasting Australia's LCC passenger demand. The modelling presented in this study offers considerable promise for future air travel demand forecasting.

REFERENCES

- Abdelghany, K & Abdelghany, A 2009, *Modelling applications in the airline industry*, Ashgate Publishing, Farnham, UK.
- Abed, SY, Ba-Fail, AO & Jasimuddin, SM 2001, 'An econometric analysis of international air travel demand in Saudi Arabia', *Journal of Air Transport Management*, vol. 7, no. 3, pp. 143-148.
- Aderamo, AJ 2010, 'Demand for air transport in Nigeria', *Journal of Economics*, vol. 1, no. 1, pp. 23-31.
- Air Transport Action Group 2000, *The economic benefits of air transport*, ATAG, Geneva.
- Air Transport Association of America 2013, *Annual results: world airlines*, viewed 22 June 2013, <<http://www.airlines.org/Pages/Annual-Results-World-Airlines.aspx>>.
- Airline Business 2006, 'JetStar moves onto the international stage', *Airline Business*, vol. 22, no. 1, p. 21.
- Aizenberg, I 2011, *Complex-valued neural networks with multi-valued neurons*, Springer-Verlag, Berlin.
- Agatonovic-Kustrin, S & Beresford, R 2000, 'Basic concepts of artificial neural network (ANN) modelling and its application in pharmaceutical research', *Journal of Pharmaceutical and Biomedical Analysis*, vol. 22, no. 5, pp. 717-727.
- Akgüngör, AP & Doğan, E 2009, 'An artificial intelligent approach to traffic accident estimation: model development and application', *Transport*, vol. 24, no. 2, pp. 135-142.
- Al-Ghandoor, A, Samhour, M, Al-Hinti, I, Jaber, J & Al-Rawashdeh, M 2012, 'Projection of future transport energy demand of Jordan using adaptive neuro-fuzzy technique', *Energy*, vol. 38, no. 1, pp. 128-135.
- Alamdari, F E & Black, IG 1992, 'Passengers' choice of airline under competition: The use of the logit model', *Transport Reviews*, vol. 12, no. 2, pp.153–170.
- Alamdari, F & Fagan, S 2005, 'Impact of the adherence to the original low cost model on the profitability of low cost airlines', *Transport Reviews*, vol. 25, no. 3, pp. 377-392.
- Alekseev, KPG & Seixas, JM 2002, Forecasting the air transport demand for passengers with neural modelling, *Proceedings of the VII Brazilian Symposium on Neural Networks (SBRN/02)*.
- Alekseev, KPG & Seixas, JM 2009, 'A multivariate neural forecasting modelling for air transport - Preprocessed by decomposition: a Brazilian application', *Journal of Air Transport Management*, vol. 15, no. 5, pp. 212-216.
- Alexander, C 2008, *Market risk analysis, quantitative methods in finance*, John Wiley & Sons, Chichester, UK.

- Alperovich, G & Machnes, Y 1994, 'The role of wealth in the demand for international air travel', *Journal of Transport Economics and Policy*, vol. 28, no. 2, pp. 163-173.
- Amjadi, MH, Nezamabadi-pour, H & Farsangi, MM 2010, 'Estimation of electricity demand of Iran using two heuristic algorithms', *Energy Conservation and Management*, vol. 51, no. 3, pp. 493-497.
- An, N, Zhao, W, Wang, J, Shang, D & Zhao, E 2013, 'Using multi-output feedforward neural network with empirical mode decomposition based signal filtering for electricity demand forecasting', *Energy*, vol. 49, 1 January, pp. 279–288.
- Anderson, JE & Kraus, M 1981, 'Quality of service and the demand for air travel', *The Review of Economics and Statistics*, vol. (63), no.4, pp. 533–540.
- Andrade, K, Uchida, K & Kagaya, S 2007, 'Development of transport mode choice model by using adaptive neuro-fuzzy inference system', *Transportation Research Record: Journal of the Transportation Research Board*, vol. 1977, pp. 8-16.
- Arkhipov, M, Krueger, E & Kurtener, D 2008, 'Evaluation of ecological conditions using bioindicators: application of fuzzy modelling', in O Gervasi, B Murgante, A Laganà, D Tanier, Y Mun & ML Gavrilova (eds), *Computational Science and its Applications - ICCSA 2008: International Conference, Perugia, Italy June/July Proceedings – Part 1*, Springer, Berlin, pp. 491-500.
- Atsalakis, G & Valavanis, KP 2009, 'Forecasting stock market short-term trends using a neuro-fuzzy based methodology', *Expert Systems with Applications*, vol. 36, no. 7, pp. 10596-10707.
- Atsalakis, G, Chnarogiannaki, E & Zopounidis, C 2014, 'Tourism demand forecasting based on a neuro-fuzzy model', *International Journal of Corporate Finance and Accounting*, vol. 1, no.1, pp. 60-69.
- Australian Aviation 2009, Jetstar to charge for 'up front' seats, *Australianaviation.com.au*, December 21[online], viewed 15 June 2014, <<http://australianaviation.com.au/2009/12/jetstar-to-charge-for-%E2%80%98up-front%E2%80%99-seats/>>
- Australian Aviation 2010, Jetstar interlines with Air France-KLM, *Australianaviation.com.au*, June 2[online], viewed 15 June 2014, <<http://australianaviation.com.au/2010/06/jetstar-interlines-with-air-france-klm/>>
- Australian Aviation 2011a, Jetstar teams up with oneworld, Finnair, *Australianaviation.com.au*, January 28[online], viewed 15 June 2014, <<http://australianaviation.com.au/2011/01/jetstar-teams-up-with-oneworld-finnair/>>
- Australian Aviation 2011b, Virgin Blue chooses ATR, *Australianaviation.com.au*, February 23 [online], viewed 8 May 2014, <<http://australianaviation.com.au/2011/02/virgin-blue-chooses-atr-reveals-some-a330-cabin-details>>.
- Australian Aviation 2011c, Jetstar takes fare bundling to the Max, *Australianaviation.com.au*, May 17 [online], viewed 15 June 2014, <<http://australianaviation.com.au/2011/05/jetstar-takes-fare-bundling-to-the-max/>>.

Australian Aviation 2011d, Jetstar announces SMS check-in, *Australianaviation.com.au*, May 24 [online], viewed 15 June 2014, < <http://australianaviation.com.au/2011/05/jetstar-announces-sms-check-in/>>.

Australian Aviation 2012, Jet and Jetstar to interline, *Australianaviation.com.au*, February 24 [online], viewed 15 June 2014, < <http://australianaviation.com.au/2012/02/jet-and-jetstar-to-interline/>>.

Australian Aviation 2013, Jetstar to stay at Avalon until 2015, *Australianaviation.com.au*, December 11 [online], viewed 15 June 2014, < <http://australianaviation.com.au/2013/12/jetstar-to-stay-at-avalon-until-2015/>>.

Australian Aviation 2014a, Emirates and Jetstar to codeshare, *Australianaviation.com.au*, February 14 [online], viewed 15 June 2014, < <http://australianaviation.com.au/2014/02/emirates-and-jetstar-to-codeshare/>>.

Australian Aviation 2014b, Tigerair launches web check, *Australianaviation.com.au*, March 11 [online], viewed 15 June 2014, <http://australianaviation.com.au/2014/03/tigerair-launches-web-check/>>.

Autry, CW, Goldsby, TJ, Bell, JE & Hill, AV 2013, *Managing the global supply chain*, Pearson Education, Upper Saddle River, NJ.

Azadeh, A, Saberi, M, Anvari, M, Azaron A & Mohammadi, M 2011, 'An adaptive network based fuzzy inference system-genetic algorithm clustering ensemble algorithm for performance assessment and improvement of conventional power plants', *Expert Systems with Application*, vol. 38, no. 3, pp. 2224-2234.

Azadeh, A, Ghaderi, SF, Taverdian, S & Saberi, M 2007, 'Integration of artificial neural networks and genetic algorithm to predict electrical energy consumption', *Applied Mathematics and Computation*, vol. 186, no. 2, pp. 1731-1741.

Azadeh, A, Saberi, M & Ghorbani, S 2010, 'An ANFIS algorithm for improved forecasting of oil consumption: a case study of USA, Russia, India and Brazil', *Journal of Scientific & Industrial Research*, vol. 69, no. 3, pp. 194-203.

Batchman, J 2012, 'Ipads help some airlines cut costs', *Business Week*, 11 June, p. 1.

Ba-Fail, AO 2004, 'Applying data mining techniques to forecast number of airline passengers in Saudi Arabia (domestic and international travels)', *Journal of Air Transportation*, vol. 9, no. 1, pp. 100-115.

Ba-Fail, AO, Abed, SY & Jasimuddin, SM 2000, 'The determinants of domestic air travel demand in the Kingdom of Saudi Arabia', *Journal of Air Transportation World Wide*, vol. 5, no. 2, pp.72-86.

Bagheri, A, Peyhani, HM & Akbari, M 2014, 'Financial forecasting using ANFIS networks with quantum-behaved particle swarm optimization', *Expert Systems with Applications*, vol. 41, no. 14, pp. 6235-6250.

Baker, D & Donnet, T 2012, 'Regional and remote airports under stress in Australia', *Research in Transportation Business & Management*, vol. 4, October, pp. 37-43.

- Barbot, C 2006, 'Low-cost airlines, secondary airports, and state aid: an economic assessment of the Ryanair-Charleroi Airport agreement', *Journal of Air Transport Management*, vol. 12, no. 4, pp. 197-203.
- Barrett, SD 2004, 'The sustainability of the Ryanair model', *International Journal of Transport Management*, vol. 2, no. 2, pp. 89-98.
- Baseri, H 2011, 'Design of adaptive neuro-fuzzy inference system for estimation of grinding performance', *Materials and Manufacturing Processes*, vol. 26, no. 5, pp. 757-763.
- Battersby, B & Oczkowski, E 2001, 'An econometric analysis of the demand for domestic air travel in Australia', *International Journal of Transport Economics*, vol. 28, no. 12, pp. 193-204.
- Bazargan, M 2010, *Airline operations and scheduling*, 2nd edn, Ashgate Publishing, Farnham, UK.
- Behboudian, S, Tabesh, M, Falahnezhad, M & Ghavanini, FA 2014, 'A long-term prediction of domestic water demand using preprocessing in artificial neural network', *Journal of Water Supply: Research and Technology – AQUA*, vol. 63, no. 1, pp.31–42.
- Belobaba, PP 2009, 'Overview of airline economics, markets and demand', in P Belobaba, A Odoni & C Barnhart (eds), *The global airline industry*, John Wiley & Sons, Chichester, UK, pp. 47-72.
- Belobaba, P & Odoni, A 2009, 'Introduction and overview', in P Belobaba, A Odoni & C Barnhart (eds), *The global airline industry*, John Wiley & Sons, Chichester, UK, pp. 1-18.
- Bevington, P & Robinson, DK 2002, *Data reduction and error analysis for the physical sciences*, 3rd edn, McGraw-Hill Science/Engineering/Math, New York.
- Bhadra, D 2003, 'Demand for air travel in the United States: bottom-up econometric estimation and implications for forecasts by origin and destination pairs', *Journal of Air Transportation*, vol. 8, no. 2, pp.19-56.
- Bhadra, D & Kee, J 2008 'Structure and dynamics of the core US air travel markets :A basic empirical analysis of domestic passenger demand' *Journal of Air Transport Management*, vol. 14, no.1, pp. 27–39.
- Bieger, T & Agosti, S 2005, 'Business models in the airline sector – evolution and perspectives', in W Delfmann, H Baum, S Auerbach & S Albers (eds), *Strategic management in the aviation industry*, Ashgate Publishing, Aldershot, UK, pp. 41-64.
- Bieger, T & Wittmer, A 2006, 'Air transport and tourism - perspectives and challenges for destinations, airlines and governments', *Journal of Air Transport Management*, vol. 12, no. 1, pp. 40-46.
- Blinova, TO 2007, 'Analysis of possibility of using neural network to forecast passenger traffic flows in Russia', *Aviation*, vol. 11, no. 1, pp. 28-34.
- Blunk, SS, Clark, DE, & McGibany, JM 2006, 'Evaluating the long-run impacts of the 9/11 terrorist attacks on US domestic airline travel', *Applied Economics*, vol. 38, no. 4, pp. 363–370.

- Borenstein, S & Rose, NL 1994, 'Competition and price dispersion in the US airline industry', *Journal of Political Economy*, vol. 102, no. 4, pp. 653-683.
- Bowen, G 2009, 'Document analysis as a qualitative research method', *Qualitative Research Journal*, vol. 9, no. 2, pp. 27-40.
- Bower, LL 1976, 'Elasticity of air travel demand with respect to airport access cost' *Transportation Research*, vol. 10, no.3, pp.193–199.
- Box, GEP, & Jenkins, GM 1970, *Time series analysis, forecasting and control*, San Francisco: Holden Day.
- Brons, M, Pels, E, Nijkamp, P & Rietveld, P 2002, 'Price elasticities of demand for passenger air travel: a meta analysis', *Journal of Air Transport Management*, vol. 8, no. 3, pp. 165-175.
- Brooke, AS, Caves, RE, & Pitfield, DE. 1994, 'Methodology for predicting European short haul air transport demand from regional airports: An application to East Midlands International Airport'. *Journal of Air Transport Management*, vol.1, no. 1, pp. 37–46.
- Brown, SL & Watkins, WS 1968, 'The demand for air travel: A regression study of time-series and cross-sectional data in the US domestic market' *Highway Research Record*, no.213, pp. 21–34.
- Bureau of Infrastructure, Transport and Regional Economics 2014a, *Domestic air fare indexes*, viewed 2 April 2014, <https://www.bitre.gov.au/statistics/aviation/air_fares.aspx>
- Bureau of Infrastructure, Transport and Regional Economics 2014b, *Domestic aviation industry annual summaries 1984–85 to 2012–13 and 1984 to 2013*, viewed 28 April 2014, <https://www.bitre.gov.au/publications/ongoing/domestic_airline_activity-time_series.aspx>
- Bureau of Transport Economics 1986, *Demand for Australian domestic aviation services*, Occasional Paper 79, Australian Government Publishing Service, Canberra.
- Bureau of Transport and Communication Economics 1991, *Deregulation of domestic aviation: the first year*, Report 73, Australian Government Publishing Service, Canberra.
- Bureau of Transport and Communication Economics 1993, *The progress of aviation reform*, Report 81, Australian Government Publishing Service, Canberra.
- Bureau of Transport and Communication Economics 1994, *International aviation: trends and issues*, Report 86, Australian Government Publishing Service, Canberra.
- Cakmakci, M 2007, 'Adaptive neuro-fuzzy modelling of anaerobic digestion of sedimentation sludge', *Bioprocess & Biosystems Engineering*, vol. 30, no. 5, pp. 349-357.
- Cakmakci, M, Kinaci, M, Bayramoglu, Y & Yildirim, Y 2010, 'A modelling approach for iron concentration in sand filtration effluent using adaptive neuro-fuzzy mode', *Expert Systems with Applications*, vol. 37, no. 2, pp.1369-1372.
- Castillo-Manzano JI, Lopez-Valpuesta, L, & Pedregal, DJ 2012, 'How can the effects of the introduction of a new airline on a national airline network be measured?. A time series

approach for the Ryanair case in Spain', *Journal of Transport Economics and Policy*, vol. 46, part 2, May 2012, pp. 263–279.

Cento, A 2009, *The airline industry: challenges in the 21st century*, Physica-Verlag, Heidelberg, Germany.

Centre for Aviation 2010, *Virgin Blue – has its “New World Carrier” experiment been a success?*, viewed 3 May 2014, <<http://centreforaviation.com/analysis/virgin-blue--has-its-new-world-carrier-experiment-been-a-success-18017>>

Centre for Aviation 2011, *Global economic crisis has cost the aviation industry two years of growth: IATA*, viewed 20 August 2014, <<http://centreforaviation.com/analysis/global-economic-crisis-has-cost-the-aviation-industry-two-years-of-growth-iata-15921>>

Centre for Aviation 2012, *Low cost carriers (LCCs): LCC capacity share (%) of total seats: 2001-2012*, viewed 6 June 2012, <<http://centreforaviation.com/profiles/hot-issues/low-cost-carriers-lccs#lcc>>

Centre for Aviation 2013, *Frequent flyer programmes: expect to see moves towards greater autonomy of these moneyspinners*, viewed 14 June 2014, <<http://centreforaviation.com/analysis/frequent-flyer-programmes-expect-to-see-moves-towards-greater-autonomy-of-these-moneyspinners-117067>>.

Ceylan, H & Ozturk, HK 2004, 'Estimating energy demand of Turkey based on economic indicators using genetic algorithm approach', *Energy Conservation and Management*, vol. 45, no. 15-16, pp. 2525-2537.

Ch, S & Mathur, S 2010, 'Modelling uncertainty analysis in flow and solute transport model using adaptive neuro fuzzy inference system and particle swarm optimization', *KSCE Journal of Civil Engineering*, vol. 14, no. 6, pp. 941-951.

Chang, LY & Hung, SC 2013, 'Adoption and loyalty towards low cost carriers: the case of Taipei-Singapore passengers', *Transportation Research Part E: Logistics and Transportation Review*, vol. 50, February, pp. 29-36.

Chang, LY 2014, 'Analysis of bilateral air passenger flows: a non-parametric multivariate adaptive regression spline approach', *Journal of Air Transport Management*, vol. 34, January, pp.123-130.

Chang, YC & Lee, N 2008, 'Are low-cost carriers a bargain? Comparison of low-cost and full-service carriers in Southeast Asia', *Transportation Research Record: Journal of the Transportation Research Board*, vol. 2052, pp. 21-27.

Chen, MS, Ying, LC & Pan, MC 2010, 'Forecasting tourist arrivals by using the adaptive network-based fuzzy inference system', *Expert Systems with Applications*, vol. 37, no. 2, pp. 1185-1191.

Chen, MY, Chen, DR, Fan, MH & Huang, TY 2013, 'International transmission of stock market movements: an adaptive neuro-fuzzy inference system for analysis of TAIEX forecasting', *Neural Computing and Applications*, vol. 23, Suppl. 1, pp. S369-S378.

- Chen, SC, Kuo, SY, Chang, KW & Wang, YT 2012, 'Improving the forecasting accuracy of air passenger and air cargo demand: the application of back-propagation neural networks', *Transportation Planning and Technology*, vol. 35, no. 3, pp. 373-392.
- Cheng, CH, Wei, LY, Liu, JW & Chen, TL 2013, 'OWA-based ANFIS model for TAIEX forecasting', *Economic Modelling*, vol. 30, January, pp. 442-448.
- Chenhall, RH & Moers, F 2007, 'The issue of endogeneity within theory-based, quantitative management accounting research', *European Accounting Review*, vol. 16, no.1 pp.173-195.
- Chi, Y, Wen, JM, Zhang, DP, Yan, JH, Ni, MJ & Cen, KF 2005, 'HCL emission characteristics and BP neural networks prediction in MSW/coal co-fired fluidized beds', *Journal of Environmental Science*, vol. 17, no. 4, pp. 699-704.
- Chiu, SL 1994, 'Fuzzy model identification based on cluster estimation', *Journal of Intelligent and Fuzzy Systems*, vol. 2, pp. 267-278.
- Choudhary, MA & Haider, A 2012, 'Neural network models for inflation forecasting: an appraisal', *Applied Economics*, vol. 44, no. 20, pp. 2631-2635.
- Chung, JY & Wang, T 2011, 'The impact of low cost carriers on Korean Island tourism', *Journal of Transport Geography*, vol. 19, no. 6, pp. 1335-1340
- Claveria, O & Torra, S 2014, 'Forecasting tourism demand to Catalonia: neural networks vs. time series models', *Economic Modelling*, vol. 36, January, pp. 220-228.
- Clements, MP & Hendry, DF. 1998, *Forecasting economic time series*, Cambridge University Press, Cambridge.
- Coelho, RF, Méndez Echenagucia, T, Pugnale, A & Richardson, JN 2014, 'Genetic algorithms for structural design', in S Adriaenssens, P Block, D Veenendaal & C Williams (eds), *Shell structures for architecture: form finding and optimization*, Routledge, Abingdon, UK, pp. 290-294.
- Collins, A, Hensher, DA & Li, Z 2010, 'Regional airports and opportunities for low-cost carriers in Australia', in MN Postorino (ed), *Development of regional airports: theoretical analyses and case studies*, WIT Press, Southampton, UK, pp. 149-174.
- Cook, A 2007, *European air traffic management: principles, practice, and research*, Ashgate Publishing, Aldershot, UK.
- Creedy, S 2004, 'Airline war takes off with \$29 fares', *The Australian*, 26 February, p.6.
- Creedy, S 2005, 'Jetstar on top in Virgin Blue', *The Australian*, 13 May, p.26.
- Crone, SF, Hibon, M & Nikolopoulos, K 2011, 'Advances in forecasting with neural networks? Empirical evidence from the NN3 competition on time series prediction', *International Journal of Forecasting*, vol. 27, no. 3, pp.635-660.
- Curcio, S & Jorio, G 2013, 'Models of membrane reactors based on artificial neural networks and hybrid approaches', in Basile, A. (Ed.), *Handbook of Membrane Reactors: Fundamental*

- Materials Science, Design and Optimisation*, Woodhead Publishing, Cambridge, UK, pp.569-597.
- Daft, J & Albers, S 2012, 'A profitability analysis of low-cost long-haul flight operations', *Journal of Air Transport Management*, vol. 19, March, pp. 197-203.
- Daraban, B 2012, 'The low cost carrier revolution continues: evidence from the US airline industry', *Journal of Business & Economics Research*, vol. 10, no. 1, pp. 37-44
- Davidson, L & Ryley, T 2010, 'Tourism destination preferences of low-cost airline users in the East Midlands', *Journal of Transport Geography*, vol. 18, May, pp. 458-465.
- de Neufville, R 2006, 'Planning airport access in an era of low-cost airlines', *Journal of the American Planning Association*, vol. 72, no. 3, pp. 347-356.
- de Neufville, R 2008, 'Low-cost airports for low-cost airlines: flexible design to manage the risk', *Transportation Planning and Technology*, vol. 31, no. 1, pp. 35-68.
- de Wit, J.G & Zuidberg, J 2012, 'The growth limits of the low cost carrier model', *Journal of Air Transport Management*, vol. 21, July, pp. 17-23.
- Debelle G 2009, *Some effects of the global financial crisis on Australian Financial Markets, Speech to Finance Professionals Forum , Sydney, 31 March 2009*, viewed 25 August 2014, <<http://www.rba.gov.au/publications/smp/index.html>>
- Dempsey, PS & Gesell, LE 1997, *Airline management: strategies for the 21st century*, Coast Aire Publications, Chandler, AZ.
- Dempsey, PS 2004, *European aviation law*, Kluwer Law International, The Hague, The Netherlands.
- Diederiks-Verschoor, IHP 2006, *An introduction to air law*, Kluwer Law International, Alphen aan den Rijn, The Netherlands.
- Dobruszkes, F 2006, 'An analysis of European low-cost airlines and their networks', *Journal of Transport Geography*, vol. 14, no. 4, pp. 249–264.
- Doganis, R 2006, *The airline business*, 2nd edn, Routledge, Abingdon, UK.
- Doganis, R 2009, *Flying off course: airline economics and marketing*, 4th edn, Routledge, Abingdon, UK.
- Dorman, C 2011, Virgin Blue ditches jets to go 'retro', *The Sydney Morning Herald*, January 31 [online], viewed 8 May 2014, <<http://www.smh.com.au/travel/blogs/travellers-check/virgin-blue-ditches-jets-to-go-retro-20110131-1aabi.html>>
- Easdown, G & Wilms, P 2002, *Ansett the collapse*, Lothian Books, Melbourne.
- Efendigil, T, Önöt, S & Kahraman, C 2009, 'A decision support system for demand forecasting with artificial neural networks and neuro-fuzzy models: a comparative analysis', *Expert Systems with Applications*, vol. 36, no.3, pp. 6697–6707.

- Ehmer, H, Berster, P, Bischoff, G, Grimme, W, Grunewald, E & Maertens, SV 2008, *Analyses of the European air transport market – airline business models*, Report 1.01, Köln: Deutsches Zentrum für Luft- und Raumfahrt e.v (DLR), viewed 23 March 2014, <http://ec.europa.eu/transport/modes/air/doc/abm_report_2008.pdf >.
- Fang, H 2012, 'Adaptive neuro fuzzy inference system in the application of the financial crisis', *International Journal of Innovation, Management and Technology*, vol. 3, no. 3, pp. 250-254.
- Faraway, J & Chatfield, C 1998, 'Time series forecasting with neural networks: a comparative study using the airline data', *Applied Statistics*, vol. 47, no. 2, pp. 231-250.
- Fernandes, E & Pacheco, RR 2010, 'The causal relationship between GDP and domestic air passenger traffic in Brazil', *Transportation Planning and Technology*, vol. 33, no. 7, pp. 569-581.
- Fernie, A 2011, *AERO2322 Airline Marketing Learning Guide Topic 1 – Strategic Planning*, RMIT University, Melbourne, Australia.
- Flenskov, K 2005, 'From production-orientation to customer-orientation – modules of a successful airline differentiation strategy', in W Delfmann, H Baum, S Auerbach & S Albers (eds), *Strategic management in the aviation industry*, Ashgate Publishing, Aldershot, UK, pp. 97-117.
- Flight International 2008, 'No luggage break cuts Qantas low cost fares', *Flight International*, vol. 173, no. 5126, p. 35
- Flouris, TG & Oswald, SL 2006, *Designing and executing strategy in aviation management*, Ashgate Publishing, Aldershot, UK.
- Formby, J, Thistle, P & Keeler, J 1990, 'Cost under regulation and deregulation: the case of the United States passenger airlines', *Economic Record*, vol. 66, no. 4, pp. 308-321.
- Forsyth, P 1998, *Airline deregulation in Australia: a medium term assessment*, Air Transport Research Group Conference, Dublin, July.
- Forsyth, P 2003, 'Low-cost carriers in Australia: experiences and impacts', *Journal of Air Transport Management*, vol.9, no. 5, pp. 277-284.
- Forsyth, P 2006, 'Aviation and tourism', in L Dwyer & P Forsyth (eds), *International handbook on the economics of tourism*, Edward Elgar Publishing, Cheltenham, UK, pp. 224-247.
- Francis, G, Dennis, N, Ison, S & Humphreys, I 2007, 'The transferability of the low-cost model to long haul operations', *Tourism Management*, vol. 28, no. 2, pp. 391-398.
- Francis, G, Humphreys, I, Ison, S & Aitken, M 2006, 'Where next for low cost airlines? A spatial and temporal comparative study', *Journal of Air Transport Geography*, vol. 14, no. 2, pp. 83-94.
- Francis, L & Knibb, D 2008, 'Jetstar shifts focus', *Airline Business*, vol. 24, no. 3, p. 23.
- Frechtling, DC 1996, *Practical Tourism Forecasting*, Butterworth-Heinemann, Oxford, UK.

- Frechtling, DC 2001, *Forecasting Tourism Demand: Methods and Strategies*, Butterworth-Heinemann, Oxford, UK.
- Freed, J 2014, Air New Zealand ups stake in Virgin Australia, *Sydney Morning Herald*, 17 June, viewed 18 June 2014, <<http://www.smh.com.au/business/aviation/air-new-zealand-ups-stake-in-virgin-australia-20140617-3a9j3.html>>.
- Friedman, JH 1991, 'Multivariate adaptive regression splines', *The Annals of Statistics*, vol.19, no.1, pp. 1-67.
- Fridström, L & Thune-Larsen, H 1989, 'An econometric air travel demand model for the entire conventional domestic network: The case of Norway', *Transportation Research*, vol. 23, no.3, pp.213–223.
- Galavi, H & Shui, LT 2012, 'Neuro-fuzzy modelling and forecasting in water resources', *Scientific Research and Essays*, vol. 7, no. 24, pp. 2112-2121.
- Gao, XZ & Ovaska, SJ 2002, 'Motor fault detection and diagnosis using soft computing', in SJ Ovaska & LM Sztandera (eds), *Soft computing in industrial electronics*, Physica-Verlag, Heidelberg, Germany, pp. 3-44.
- Garrido, C, De Oña, R & De Oña, J 2014, 'Neural networks for analyzing service quality in public transportation', *Expert Systems with Applications*, vol. 41, no. 15, pp. 6830–6838.
- Gately, E 1996, *Neural networks for financial forecasting*, NY: Wiley, New York.
- Gen, M & Cheng, R 1997, *Genetic algorithms and engineering design*, John Wiley & Sons, New York.
- Georgieva, O, Klawonn, E & Härtig, E 2005, 'Fuzzy clustering of macroarray data', in B Reusch (ed), *Computational intelligence, theory and applications*, Springer, Berlin-Heidelberg, pp. 83-94.
- Gesell, LE 1993, *The administration of public airports*, 3rd edn, Coast Aire Publications, Chandler, AZ.
- Ghanbari, A, Kzemi, SMR, Mehmanpazir, F & Nakhostin, MM 2013, 'A cooperative ant colony optimization-genetic algorithm approach for construction of energy demand forecasting knowledge-based expert systems', *Knowledge-Based Systems*, vol. 39, February, pp. 194-206.
- Ghassemzadeh, S, Shafflie, M, Sarrafi, A & Ranjbar, M 2013, 'The importance of normalization in predicting dew point pressure by ANFIS', *Petroleum Science and Technology*, vol. 31, no. 10, pp. 1040-1047.
- Ghobrial, A 1992, 'An aggregate demand model for domestic airlines', *Journal of Advanced Transportation*, vol. 26, no. 2, pp. 105-119.
- Ghosch, R, Ghosch, M, Yearwood, J & Bagirov, A 2005, 'Determining regularization parameters for derivative neural learning', in P Perner & A Imiya (eds), *Machine learning and data mining in pattern recognition: 4th International Conference, MLDM 2005*, Leipzig, Germany, pp. 71-79.

- Gillen, D & Lall, A 2004, 'Competitive advantage of low cost carriers: some implications for airports', *Journal of Air Transport Management*, vol. 10, no. 1, pp. 41-50.
- Giovanis, E 2012, 'Study of discrete and adaptive neuro-fuzzy inference system in the prediction of economic crisis periods in USA', *Economic Analysis & Policy*, vol. 42, no. 1, pp. 79-95.
- Godinho, P & Silva, M 2014, 'Genetic, memetic and electromagnetism-like algorithms: applications in marketing', in L Moutinho, E Bigné & AK Manrai (eds), *The Routledge companion to the future of marketing*, Routledge, Abingdon, UK, pp. 393-416.
- Goh, M 2005, 'Low cost carriers in Southeast Asia: a preliminary analysis', in W Delfmann, H Baum, S Auerbach & S Albers (eds), *Strategic management in the aviation industry*, Ashgate Publishing, Aldershot, UK, pp. 143-163.
- Goldberg, DE 1989, *Genetic algorithms in search, optimization, and machine learning*, Addison-Wesley, Reading, MA.
- Gonzalez, S 2000, *Neural Networks for Macroeconomic Forecasting: A Complementary Approach to Linear Regression Models*, Finance Canada Working Paper 2000-07, [online] <http://www.machine-learning.martinsewell.com/ann/Gonz00.pdf> (accessed 10 December 2014).
- Goolsbee, A 2010, *Economic impact of recent temporary unemployment insurance extensions*, Dianne Publishing, Darby, PA.
- Goyal, MK, Bharti, B, Quilty, J Adamowski, J & Pandey, A 2014, 'Modelling of daily pan evaporation in sub tropical climates using ANN, LS-SVR, fuzzy logic, and ANFIS', *Expert Systems with Applications*, vol. 41, no.11, pp. 5267-5276.
- Graham, A 2000, 'Demand for leisure air travel and limits to growth', *Journal of Air Transport Management*, vol. 6, no. 2, pp. 109-118.
- Graham, A 2006, 'Have the major forces driving leisure airline traffic changed?', *Journal of Air Transport Management*, vol. 12, no. 1, pp. 109-118.
- Graham, B & Shaw, J 2008, 'Low-cost airlines in Europe: reconciling liberalization and sustainability', *Geoforum*, vol. 39, no. 3, pp.1439-1451.
- Grosche, T, Rothlauf, F, & Heinzl, A 2007, 'Gravity models for airline passenger volume estimation', *Journal of Air Transport Management*, vol.13, no. 4, pp.175–183.
- Grimm, CM & Molloy, HB 1993, 'Australian domestic aviation deregulation: impacts and implications', *Logistics and Transportation Review*, vol. 29, no. 3, pp. 259-273.
- Gu, J, Mingcang, Z & Liuguangyan, J 2011, 'Housing price forecasting based on genetic algorithm and support vector machine', *Expert Systems with Applications*, vol. 38, no.4, pp. 3383-3386.
- Gujarati, DN 2003, *Basic econometrics*, McGraw-Hill, New York.
- Gujarati, DN 2006, *Essentials of econometrics*, McGraw-Hill Irwin, New York.

- Hadavandi, E, Ghanbari, A, Shahanaghi, K & Abbasian-Naghneh, S 2011, 'Tourist arrival forecasting by evolutionary fuzzy systems', *Tourism Management*, vol. 32, no. 5, pp.1196-1203.
- Hagan, HB & Demuth MB 1996, *Neural Network Design*, PWS Publishing Company, Boston, USA.
- Haldenbilen, S & Ceylan, H 2005, 'Genetic algorithm approach to estimate transport energy demand in Turkey', *Energy Policy*, vol. 33, no, 1, pp. 89-98.
- Hamal, K, 2012, '*Modelling air passenger movements through Australia's non-capital city airports*', The 35th Australian Transport Research Forum (ATRF) Annual Conference, Perth Australia, September 26-28, 2012, pp. 1-10.
- Hanlon, P 2007, *Global airlines: competition in a transnational industry*, 3rd edn, Butterworth-Heinemann, Oxford, UK.
- Hansen, JV, McDonald, JB & Nelson, R D 1999, 'Time series prediction with genetic-algorithm designed neural networks', *Computational Intelligence*, vol. 15, no. 3, pp. 171-184.
- Hazledine, T 2009, 'Border effects for domestic and international Canadian passenger air travel', *Journal of Air Transport Management*, vol. 15, no.1, pp. 7-13.
- Haykin, S 1999, *Neural networks: a comprehensive foundation*, 2nd edn, Prentice Hall, New York.
- Hernández-López, M & Cáceres-Hernández, JJ 2007, 'Forecasting tourists' characteristics by a genetic algorithm with a transition matrix', *Tourism Management*, vol. 28, no.1, pp. 290–297.
- Holland, JH 1975, *Adaption in natural and artificial systems*, University of Michigan Press, Ann Arbor.
- Holloway, S 2008, *Straight and level: practical airline economics*, 3rd edn, Ashgate Publishing, Aldershot, UK.
- Homsombat, W, Lei, Z & Fu, X 2014, 'Competitive effects of the airlines-within-airlines strategy: pricing and route entry patterns', *Transportation Research Part E: Logistics and Transportation Review*, vol. 63, March, pp. 1-16.
- Hong, WC, Dong, Y, Chen, LY & Wei, SY 2011, 'SVR with hybrid chaotic genetic algorithms for tourism demand forecasting', *Applied Soft Computing*, vol. 11, no. 2, pp.1881-1890.
- Hooper, P 1998, 'Airline competition and deregulation in developed and developing country contexts – Australia and India', *Journal of Transport Geography*, vol. 6, no. 2, pp. 105-116.
- Hopfield, JJ 1982, 'Neural networks and physical systems with emergent collective computational abilities', *PNAS*, vol.79, no. 8, pp. 2554-2558.
- Horton, W 2010, 'Ipad offers new choice for in-flight entertainment', *Flight International*, 7 September –13 September, p. 33.
- Hooper, K & van Zyl, M 2011, 'Australia's tourism industry', *Bulletin*, December, pp. 23-32.

- Hu, C 2002, *Advanced tourism demand forecasting: artificial neural network and Box-Jenkins modelling* (unpublished PhD thesis), Purdue University, USA, viewed 6 August 2014, <<http://docs.lib.purdue.edu/dissertations/AAI3104960/>>
- Hunter, L 2006, 'Low cost airlines: business model and employment relations', *European Management Journal*, vol. 24, no. 5, pp. 315-321.
- Hurley, S, Moutinho, L & Witt, S 1998, 'Genetic algorithms for tourism marketing', *Annals of Tourism Research*, vol. 25, no. 2, pp. 498-514.
- Hutchinson, BG 1993, 'Analyses of Canadian air travel demands', *Journal of Transportation Engineering*, vol. 119, no. 2, pp. 301-316.
- International Air Transport Association 2008, *Air travel demand*, IATA Economics Briefing No. 9, viewed 20 May 2014, <http://www.iata.org/whatwedo/Documents/economics/air_travel_demand.pdf>.
- International Air Transport Association 2014, *Financial forecast: Profits still rising but so is risk*, viewed 27 August 2014, <<http://www.iata.org/whatwedo/Documents/economics/IATA-economic-briefing-financial-forecast-March-2014.pdf>>.
- International Civil Aviation Organization 2006, *Manual on air traffic forecasting*, 3rd edn, Document 8991, AT/722/3, ICAO, Montreal.
- International Civil Aviation Organization 2008, *Annual Report of the Council – 2007*, Document No. 9898, ICAO, Montreal.
- International Civil Aviation Organization 2009, *Annual Report of the Council – 2008*, Document No. 9916, ICAO, Montreal.
- International Civil Aviation Organization 2011, *Annual Report of the Council – 2010*, Document No. 9952, ICAO, Montreal.
- International Civil Aviation Organization 2012, *Annual Report of the Council – 2011*, Document No. 9975, ICAO, Montreal.
- International Civil Aviation Organization 2013, *Annual Report of the Council – 2012*, Document No. 10001, ICAO, Montreal.
- International Monetary Fund 2014, *World economic database – April 2014*, IMF, Washington.
- Ionides, N 2005, 'Jetstar Asia stretches out', *Airline Business*, vol. 21, no. 1, p. 30.
- Ionides, N 2007a, 'Jetstar launches long-haul services', *Airline Business*, vol. 23, no. 1, p. 23.
- Ionides, N 2007b, 'Attention seeker', *Airline Business*, vol. 23, no. 6, pp. 33-36.
- Ionides, N 2007c, 'Jetstar plan very large A320 order', *Flight International*, 31 July – 6 August, p. 172.

- Ionides, N 2008, 'Australian carriers held up', *Airline Business*, vol. 24, no. 11, p. 44.
- Ironside, R 2012, Budget airline Air Australia placed in administration, *The Courier-Mail*, 17 February [online], viewed 29 March 2014, <<http://www.couriermail.com.au/news/queensland/budget-airline-air-australia-placed-in-administration/story-e6freoof-1226273391831>>
- Jacobs. RA, Jordan, MI, Nowlan, SJ, Hinton, GE 1991, 'Adaptive mixture of local experts', *Neural Computation*, vol. 3, no.1, pp. 79–87.
- Jang, JSR 1993, 'ANFIS-adaptive-network-based fuzzy inference system', *IEEE Transactions Systems, Man and Cybernetics*, vol. 23, no. 3, pp. 665-685.
- Jang, JSR, Sun, CT & Mizutani, E 1997, *Neuro-fuzzy soft computing: a computational approach to learning and machine intelligence*, Prentice Hall, New Jersey.
- Janić, M 2011, *Greening airports: advanced technology and operations*, Springer, London.
- Jarimillo-Morán, MA, González, E & Carmona-Fernández, D 2013, 'Monthly electric demand forecasting with neural filters', *International Journal of Electric Power & Energy Systems*, vol. 49, July, pp. 253-263.
- Jeon, J 2007, *Fuzzy and neural network models for analyses of piles*, Proquest Information and Learning Company, Ann Arbor, MI.
- Jetstar Airways 2013a, *About us: our company*, viewed 23 March 2014, <<http://www.jetstar.com/au/en/about-us/our-company>>
- Jetstar Airways 2013b, *About us: our fleet*, viewed 24 March 2014, <<http://www.jetstar.com/au/en/about-us/our-fleet>>
- Jetstar Airways 2013c, *Qantas points*, viewed 14 June 2014, <<http://www.jetstar.com/au/en/planning-and-booking/booking-with-jetstar/qantas-points>>
- Jetstar Airways 2013d, *Travel agents*, viewed 14 June 2014, <<http://www.jetstar.com/hk/en/what-we-offer/travel-agents>>
- Jetstar Airways 2014, *About us: our company*, viewed 27 August 2014, <<http://www.jetstar.com/au/en/about-us/our-company>>.
- Jiang, D, Zhang, Y, Hu, X, Zheng, Y, Tan, J & Shao, D 2004, 'Progress in developing an ANN model for air pollution index forecast', *Atmospheric Environment*, vol. 38, no. 40, pp. 7055–7064.
- Jiménez, F, Serradilla, F, Román, A & Naranjo, JE 2014, 'Bus line classification using neural networks', *Transportation Research Part D: Transport and Environment*, vol. 30, July, pp. 32-37.
- Jung, I & Wang, GN 2007, 'Pattern classification of back propagation algorithm using exclusive connection network', *World Academy of Science, Engineering and Technology*, vol. 1, pp. 189-193.

- Kablan, A 2009, 'Adaptive neuro-fuzzy inference system for financial training using intraday seasonality observation model', *World Academy of Science, Engineering and Technology*, vol. 3, pp. 10-24.
- Kain, J & Webb, R 2003, *Turbulent times: Australian airline industry*, Information and Research Services, Department of the Parliamentary Library, Canberra.
- Kalkhaheh, YK, Arshad, RR, Amerikhah, H & Sami, M 2012, 'Comparison of multiple linear regressions and artificial intelligence-based modelling techniques for prediction the soil cation exchange capacity of Aridisols and Entisols in a semi-arid region', *Australian Journal of Agricultural Engineering*, vol. 3, no. 2, pp. 39-46.
- Kar, S, Das, S & Ghosh, PK 2014, 'Applications of neuro fuzzy systems: a brief review and future outline', *Applied Soft Computing*, vol. 15, February, pp. 243-259.
- Karlaftis, MG 1994, *Critical review and analysis of air travel demand forecasting models*, viewed 30 August 2014, <<http://www.irma-international.org/viewtitle/38103/>>.
- Katarellos, E & Koufodontis, I 2012, 'Business relations between the low cost carriers and airports as a consequence of the air transport deregulation', *Journal of Air Transport Studies*, vol. 3, no. 1, pp. 57-77.
- Kazda, A & Caves, RE 2007, *Airport design and operation*, 2nd edn, Elsevier, Jordon Hill, UK.
- Killian, M 2001, The twin-engine Cockatoo, *Airliner World*, p. 8.
- Kim, KW, Seo, HY & Kim, Y, 2003, 'Forecast of domestic air travel demand change by opening the high speed rail', *KSCE Journal of Transport Engineering*, vol. 7, no. 5, pp. 603-609.
- Klaas, T & Klein, J 2005, 'Strategic airline positioning in the German low cost carrier (LCC) market', in W Delfmann, H Baum, S Auerbach & S Albers (eds), *Strategic management in the aviation industry*, Ashgate Publishing, Aldershot, UK, pp. 119-142.
- Klophaus, R, Conrady, R & Fichert, F 2012, 'Low cost carriers going hybrid: evidence from Europe', *Journal of Air Transport Management*, vol. 23, August, pp.54-58.
- Knibb, D 2004a, 'Jetstar takes shape for May start', *Airline Business*, vol. 20, no. 1, p. 21.
- Knibb, D 2004b, 'Virgin Blue makes an early attack on start-up Jetstar', *Airline Business*, vol. 20, no. 2, p. 22.
- Knibb, D 2005, 'Virgin Blue seeks home for cheap 737s', *Airline Business*, vol.21, no. 9, p. 30.
- Knibb, D 2006, 'JetStar moves onto the international stage', *Airline Business*, vol. 22, no. 1, p. 21.
- Knibb, D 2007a, 'Attention seeker', *Airline Business*, vol.23, no. 6, pp. 33-36.
- Knibb, D 2007b, 'Tiger prompts Jetstar rule change', *Airline Business*, vol. 23, no. 8, p. 30.

- Knibb, D 2007c, 'Bridge building', *Airline Business*, vol. 23, no. 9, pp. 80-83.
- Knibb, D 2007d, 'Reinvention time in Australia', *Airline Business*, vol. 23, no. 9, p. 28.
- Knibb, D 2007e, 'The winner is...V Australia', *Airline Business*, vol. 23, no. 9, p. 32.
- Knibb, D 2008a, 'Toll seeks to reduce Virgin stake', *Airline Business*, vol. 24, no. 4, p. 28.
- Knibb, D 2008b, 'Silver lining', *Airline Business*, vol. 24, no. 9, pp. 54-55.
- Knibb, D 2012, 'Will three into two go in Australia?', *Airline Business*, vol. 28, no. 12, p. 14.
- Koch, B 2010, 'Aviation strategy and business models', in A Wald, C Fay & R Gleich (eds), *Introduction to aviation management*, LIT Verlag, Münster, Germany, pp. 143-184.
- Kochak, A & Sharma, S 2015, 'Demand forecasting using neural network for supply chain management', *International Journal of Mechanical Engineering and Robotics Research*, vol. 4, no. 1, pp.96-104.
- Kohonen, T 1988, 'An introduction to neural computing', *Neural Network*, vol. 1, no. 1, pp. 3-16.
- Kong, L 1999, 'The geography of air transport in Australasia: a global perspective', *Australian Geographical Studies*, vol. 37, no. 2, pp.105-113.
- Koo, TTR 2009, *The effects of low-cost carriers on regional dispersion of domestic visitors in Australia* (unpublished PhD thesis), University of New South Wales, Sydney, NSW, Australia.
- Koo, TTR & Lohmann, G 2013, 'The spatial effects of domestic aviation deregulation: a comparative study of Australian and Brazilian seat capacity, 1986–2010', *Journal of Transport Geography*, vol. 29, May, pp. 52-62.
- Koo, TTR, Tan, DT & Duval, DT 2013, 'Direct air transport and demand interaction: a vector error-correction model approach', *Journal of Air Transport Management*, vol. 28, May, pp. 14-19.
- Kopsch, F 2012, 'A demand model for domestic air travel in Sweden', *Journal of Air Transport Management*, vol. 20, May, pp. 46-48.
- Köse, U & Arslan, A 2013, 'An adaptive neuro-fuzzy inference system-based approach to forecast time-series of chaotic systems', in S Banerjee & SS Erçetin (eds), *Chaos, complexity and leadership 2012*, Springer Proceedings in Complexity, Springer Science + Business Media, Dordrecht, The Netherlands, pp.17-22.
- KPMG 2006, *Economic impact study of the Melbourne 2006 Commonwealth Games Post-event analysis*, Office of Commonwealth Games Coordination, viewed 15 April 2014, <http://www1.dvc.vic.gov.au/ocgc/News/econ_impact_report.pdf>.
- Kropp, T 2010, 'Aviation policy', in A Wald, C Fay & R Gleich (eds), *Introduction to aviation management*, LIT Verlag, Münster, Germany, pp. 257-275.

- Kua, J & Baum, T 2004, 'Perspectives on the development of low-cost airlines in South-east Asia', *Current Issues in Tourism*, vol. 7, no. 3, pp. 262-276.
- Kumar, JS, Subbaiah, KV & Rao, VP 2011, 'Prediction of municipal solid waste with RBF NetWork – a case study of Eluru, A.P, India', *International Journal of Innovation, Management and Technology*, vol. 2, no. 3, pp. 238-243.
- Kunt, MM, Aghayan, I & Noii, N 2011, 'Prediction for traffic accident severity: comparing the artificial neural network, genetic algorithm, combined genetic algorithm and pattern search methods', *Transport*, vol. 26, no. 4, pp. 353-366.
- Kuo, RJ 2001, 'A sales forecasting system based on fuzzy neural network with initial weights generated by genetic algorithm', *European Journal of Operational Research*, vol. 129, no. 3, pp. 496-517.
- Lahmiri, S 2011, 'A comparative study of backpropagation algorithms in financial prediction', *International Journal of Computer Science, Engineering and Applications*, vol. 1, no. 4, pp. 15-21.
- Lai, SL, & Lu, WL. 2005, 'Impact analysis of September 11 on air travel demand in the USA', *Journal of Air Transport Management*, vol. 11, no.6, pp.455–458.
- Lall, A. 2005. 'Predatory pricing: still a rare occurrence?', in P Forysth, DW Gillen, OG Mayer & HM Niemeier (eds), *Competition versus predation in aviation markets: a survey of experience in North America, Europe and Australia*, Ashgate Publishing, Aldershot, UK, pp. 37-56.
- Lannen, D 2014, Avalon faith in Jetstar deal, *The Geelong Advertiser* (Online), February 25, viewed 28 August 2014, <<http://www.geelongadvertiser.com.au/news/geelong/avalon-faith-in-jetstar-deal/story-fnjuhovy-1226838021848>>.
- Lansing, JB, Liu, J C, & Suits, DB 1961, 'An analysis of interurban air travel' *The Quarterly Journal of Economics*, vol.75, no.1 , pp. 87–95.
- Lam, WHK & Xu, J 2000, 'Estimation of AADT from short period counts in Hong Kong: a comparison between neural network method and regression analysis', *Journal of Advanced Transportation*, vol. 34, no. 2, pp. 249-268.
- Laplante, PA 2005, *Comprehensive dictionary of electrical engineering*, 2nd edn, CRC Press, Boca Raton, FL.
- Latif, HH, Paul, SK & Azeem, A 2014, 'Ordering policy in a supply chain with adaptive neuro-fuzzy inference system demand forecasting', *International Journal of Management Science and Engineering Management*, vol. 9, no. 2, pp. 114-124.
- Lawton, TC 2002, *Cleared for take-off: structure and strategy in the low fare airline business*, Ashgate Publishing, Aldershot, UK.
- Lee, CF, Lee, JC & Lee, AC 2013, *Statistics for business and financial economics*, Springer, New York.

- Li, G 2010, 'The nature of leisure travel demand', in A Graham, A Papatheodorou & P Forsyth (eds), *Aviation and tourism: implications for leisure travel*, Ashgate Publishing, Aldershot, UK, pp. 7-20.
- Lindsay, B 2007, 'Tiger Airways licks chop at Australia', *The Wall Street Journal*, 14 February, p. B.9..
- Liu, C, Liu, X, Huang, H & Zhao, L 2008, 'Low circle fatigue life model based on ANFIS', in DS Huang, DC Wunsch II, DS Levine & KH Jo (eds), *Advanced intelligent computing theories and applications: with aspects of contemporary intelligent computing techniques*, Springer Verlag, Berlin, pp. 139-144.
- Love, R, Goth, J, Budde, F, Schilling, D & Woffenden, B 2006, 'Understanding the demand for air travel: how to compete more effectively – Meeting the new challenges of the airline industry', *BCG Focus*, June, pp. 1-8.
- Macchiavelli, A & Cinesi, L 2006, 'Low cost tourism and real estate demand', in P Keller & T Bieger (eds), *Real estate and destination development in tourism: successful strategies and instruments*, Erich Schmidt Verlag, Berlin, pp. 63-77.
- Maddala, GS 2001, *An introduction to econometrics*, 3rd edn, John Wiley and Son, Chichester, UK..
- Makridakis, S & Hibon, M 2000, 'The M3-Comeptition, results, conclusions and implications', *International Journal of Forecasting*, vol. 16, no. 4, pp.451-476.
- Makridou, G, Atsalakis, GS, Zopounidis, C & Andriosopoulos, K 2013, 'Gold price forecasting with a neuro-fuzzy inference system', *International Journal of Financial Engineering and Risk Management*, vol. 1, no. 1, pp. 35-54.
- Martin, N 1991, *The bottom line: a student guide to economics*. Marrickville, Australia, Harcourt Brace Jovanovich Group.
- Martin del Bío, B & Sanz Molina, A 2006, *Neural networks and fuzzy systems: editorial*, RAMA, Madrid.
- Martin, CA & Witt, SF 1989, 'Accuracy of econometric forecasts of tourism', *Annals of Tourism Research*, vol. 16, no. 3, pp. 407-428.
- Mason, KJ 2001, 'Marketing low-cost airline services to business travellers', *Journal of Air Transport Management*, vol. 7, no. 3, pp. 103-109.
- Mason, KJ 2005, 'Observations of fundamental changes in the demand for aviation services', *Journal of Air Transport Management*, vol. 11, no. 1, pp. 19-25.
- Mason, KJ 2007, 'Airframe manufacturers: which has the better view of the future?,' *Journal of Air Transport Management*, vol. 13, no. 1, pp. 9-15.
- May, T, Butcher, EWA & Mills, G 1986, *Independent review of economic regulation of domestic aviation: report prepared for the Minister of Transport*, Australian Government Publishing Service, Canberra.

- Mayhill, GR 1953, 'A critique of the CAA studies on air traffic generation in the United States', *Journal of Air Law and Commerce*, vol. 20, pp. 158-177.
- Mayilvaganan, MK & Naidu, KB 2011, 'Comparison of membership functions in adaptive network-based neuro-fuzzy inference system (ANFIS) for the prediction of groundwater level of a watershed', *Journal of Computer Applications Research and Development*, vol. 1, no. 1, pp. 35-42.
- McKnight, P 2010, 'Airline economics', in A Wald, C Fay & R Gleich (eds), *Introduction to aviation management*, LIT Verlag, Münster, Germany, pp. 25-53.
- Mehrotra, K, Mohan, CK & Ranka, S 2000, *Elements of artificial neural networks*, The MIT Press, Cambridge, MA.
- Mehta, R & Jain, S 2009, 'Optimal operation of a multi-purpose reservoir using neuro-fuzzy technique', *Water Research Management*, vol. 23, no. 3, pp. 509-529.
- Melville, JA 1998, 'An empirical model for the demand for international air travel for the Caribbean region', *International Journal of Transport Economics*, vol. 25, no. 3, pp. 313-336.
- Michalewicz, Z, Schmidt, M, Michalewicz, M & Chiriack, C 2006, *Adaptive business intelligence*, Springer Science & Business Media, Heidelberg.
- Mills, G 1989, 'The reform of Australian aviation', *Journal of Transport Economics and Policy*, vol. 23, no. 2, pp. 209-218.
- Mitchell, M 1998, *An introduction to genetic algorithms*, MIT Press, Cambridge MA.
- Mitsa, T 2010, *Temporal data mining*, Chapman & Hall/ CRC, Boca Raton, FL.
- Mittal, A, Sharma, S & Kanungo, DP 2012, 'A comparison of ANFIS and ANN for the prediction of peak ground acceleration in Indian Himalayan region', in K Deep, A. Nagar & M Pant (eds), *Proceedings of the International Conference on Soft Computing for Problem Solving (SocProS 2011), December 20-22, 2011*, Springer India, New Delhi, pp. 485-495.
- Moens, P & Gillies, G 2000, *International trade and business: law, policy and ethics*, Cavendish Publishing (Australia), Sydney.
- Momoh, J 2012, *Smart Grid: Fundamentals of Design and Analysis*, John Wiley & Sons, Hoboken, NJ.
- Moore, V 2009, *Virgin Blue's long-haul arm V-Australia commences flights*, viewed 12 June 2014, <<http://www.flightglobal.com/articles/2009/02/27/323180/virgin-blues-long-haul-arm-v-australia-launches-flights.html>>.
- Morrell, P & Swan, W 2006, 'Airline jet fuel hedging: Theory and practice', *Transport Reviews*, vol. 26, no. 6, pp. 713-730.
- Morrell, P 2008, 'Can long-haul low-cost airlines be successful?', *Research in Transportation Economics*, vol. 24, no. 1, pp. 61-67.

- Mourani, I, Hennequin, S & Xie, X 2006, 'Optimisation of assembly lines with transportation delay using IPA', in DT Pham, EE Eldukhri & AJ Soroka (eds), *Intelligent production machines and systems*, Elsevier, Kidlington, UK, pp. 338-349.
- Mrugalski, M 2013, 'An unscented Kalman filter in designing dynamic GMDH neural networks for robust fault detection', *International Journal of Applied Mathematics and Computer Science*, vol. 23, no. 1, pp. 157–169.
- Nam, K & Schaefer, T 1995, Forecasting international airline passenger traffic using neural networks, *Logistics and Transportation Review*, vol. 31, no. 3, pp. 239-251.
- Nancarrow, D 2011, Australia gets a new budget airline, *The Sydney Morning Herald*, November 3 [online], viewed 29 March 2014, <<http://www.smh.com.au/travel/travel-news/australia-gets-a-new-budget-airline-20111103-1mwm5.html>>
- Nolan, JL (ed) 1996, *Australia business: the portable encyclopaedia for doing business with Australia*, World Trade Press, San Rafael, CA.
- Noori, R, Abdoli, MA, Farokhnia, A, & Abbasi, M 2009 'Results uncertainty of solid waste generation forecasting by hybrid of wavelet transform-ANFIS and wavelet transform-neural network', *Expert Systems with Applications*, vol. 36, no.6, pp.9991-9999.
- Nyathi, M, Hooper, P & Hensher, D 1993a, 'Compass Airlines: 1 December 1990 to 20 December 1991 what went wrong? – Part 1', *Transport Reviews*, vol. 13, no. 2, pp. 119-149.
- Nyathi, M, Hooper, P & Hensher, D 1993b, 'Compass Airlines: 1 December 1990 to 20 December 1991 what went wrong? – Part 2', *Transport Reviews*, vol. 13, no. 3, pp. 185-206.
- Oberhausen, PJ, & Koppelman, FS 1982, 'Time series analysis of intercity air travel modes', *Transportation Research Record*, no. 840, pp.15–21.
- Olipra, L 2012, The impact of low-cost carriers on tourism development in less famous destination, *CITTASLOW: il valore della lentezza per il turismo del future*. Perugia/Orvieto, 13-14 giugno 2012, pp. 41-56
- Organization for Economic Cooperation and Development (OECD) 2014, *OECD tourism trends and policies 2014*, OECD Publishing, Paris.
- Osbourne, JW & Waters, E. 2002, 'Four assumptions of multiple regression that researchers should always test', *Practical Assessment, Research, and Evaluation*, vol. 8, no. 2, pp. 1–5.
- O'Sullivan, M 2012, Flying Qantas just got more expensive, *Sydney Morning Herald* (Online), February 2, viewed 27 August 2014, <<http://www.smh.com.au/travel/travel-planning/travel-news/flying-qantas-just-got-more-expensive-20120202-1qv1y.html>>.
- Owen-Brown, M. 2003, 'Cheap, no-frills Qantas flights on way', *The Advertiser*, 02 December, p.9.
- Ozturk, HK, Ceylan, H, Canyur, OE & Hepbasli, A 2005, 'Electricity estimation using genetic algorithm approach: a case study of Turkey', *Energy*, vol. 30, no. 7, pp. 1003–1012.

- Palmer, A, José Montaña, J & Sesé, A 2006, 'Designing an artificial neural network for forecasting tourism time series', *Tourism Management*, vol. 27, no. 5, pp. 781-790.
- Pan, Y, Pohlen, T & Manago, S 2013, 'Hybrid neural network model in forecasting U.S. retail sales', in KD Lawrence & RK Klimberg (eds), *Advances in business and management forecasting*, Volume 9, Emerald Publishing Group, Bingley, UK, pp.153-170.
- Pantazis, N & Liefner, I 2006, 'The impact of low cost carriers on catchment areas of established international airports: the case of Hanover Airport, Germany', *Journal of Transport Geography*, vol. 14, no. 4, pp. 265-272.
- Panizzo, A & Petaccia, A 2009, 'Analysis of monitoring data for the safety control of dams using neural networks', in FG Zhuang & JC Li (eds), *New trends in fluid mechanics research: Proceedings of the Fifth International Conference of Fluid Mechanics*, Shanghai, Tsinghua University Press, pp. 344-351.
- Patil, SG, Mandal, S, Hegde, AV & Alavandar, S 2011, 'Neuro-fuzzy based approach for wave transmission prediction of horizontally interlaced multilayer moored floating pipe breakwater', *Ocean Engineering*, vol. 38, no. 1, pp.186-196.
- Penner, JE 1999, *Aviation and the global atmosphere: a special report of IPCC Working Groups*, Cambridge University Press, Cambridge, UK.
- Pitfield, DE 2007, 'The impact on traffic, market shares and concentration of airline alliances on selected European—US routes', *Journal of Air Transport Management*, vol. 13, no. 4, pp. 192-202.
- Pitfield, DE 2008, 'The Southwest effect: A time-series analysis on passengers carried by selected routes and a market share comparison', *Journal of Air Transport Management*, vol. 14, no. 3, pp.113-122.
- Pitt, MR & Brown, AW 2001, 'Developing a strategic direction for airports to enable the provision of services to both network and low-fare carriers', *Facilities*, vol. 19, no. 1-2, pp. 52-60.
- Poore, JW 1993, 'Forecasting the demand for air transportation services', *Journal of Transportation Engineering*, vol. 19, no. 5, pp. 22-34.
- Priddy, KL & Keller, PE 2005, *Artificial neural networks: an introduction*, SPIE Press, Bellingham, WA.
- Prideaux, B 2003, 'The need to use disaster planning frameworks to respond to major tourism disasters: analysis of Australia's response to tourism disasters in 2001', *Journal of Travel & Tourism Marketing*, vol. 15, no. 4, pp. 281-298.
- Profillidis, VA, 2000, 'Econometric and fuzzy models for the forecast of demand in the airport of Rhodes'. *Journal of Air Transport Management*, vol. 6, no. 2, pp. 95-100.
- Qantas Airways 2004, *Qantas annual report 2004*, viewed 21 December 2013, <<http://www.qantas.com.au/infodetail/about/investors/2004AnnualReport.pdf>>
- Qantas Airways 2009, *Qantas data book 2008/09*, viewed 21 December 2013, <<http://www.qantas.com.au/infodetail/about/investors/qantasDataBook20082009.pdf>>

- Qantas Airways 2010, *Qantas data book 2010*, viewed 21 December 2013, <<http://www.qantas.com.au/infodetail/about/investors/qantasDataBook2010.pdf>>
- Qantas Airways 2011, *Qantas data book 2011*, viewed 21 December 2013, <<http://www.qantas.com.au/infodetail/about/investors/qantasDataBook2011.pdf>>
- Qantas Airways 2012, *Qantas data book 2012*, viewed 21 December 2013, <<http://www.qantas.com.au/infodetail/about/investors/qantas-data-book-2012.pdf>>
- Qantas Airways 2012, *Qantas Group policy on higher fuel prices and carbon pricing*, viewed 27 August 2014, <<http://www.qantas.com.au/travel/airlines/media-releases/feb-2012/5363/global/en>>.
- Qantas Airways 2013, *The transformation continues: Qantas data book 2013*, viewed 21 December 2013, <<http://www.qantas.com.au/infodetail/about/investors/qantas-data-book-2013.pdf>>
- Quiggin, J 1997, 'Evaluating airline deregulation in Australia', *The Australian Economic Review*, vol. 30, no. 1, pp. 45-56.
- Quinlin, HG 1998, 'Air services in Australia: growth and corporate change, 1921-1996', *Australian Geographical Studies*, vol. 36, no. 2, pp. 156-169.
- Rachev, ST, Hoehstoetter, M, Fabozzi, FJ & Focardi, SM 2010, *Probability and statistics for finance*, John Wiley & Sons, Hoboken, NJ.
- Rao, RV 2011, *Advanced modelling and optimization of manufacturing processes: international research and development*, Springer-Verlag, London.
- Raşit, A 2009, 'An adaptive neuro-fuzzy inference system approach for prediction of power factor in wind turbines', *Journal of Electrical & Electronics Engineering*, vol. 9, no. 1, pp. 905-912.
- Reisinger, Y 2009, *International tourism: cultures and behaviour*, Butterworth-Heinemann, Oxford Hill, UK.
- Remus, W & O'Connor, M 2001, 'Neural networks for time-series forecasting', in JS Armstrong (ed), *Principles of forecasting: a handbook for researchers and practitioners*, Springer Science + Business, New York, pp. 245-256.
- Rengaraju, VR & Arasan, VI 1992, 'Modelling for air travel demand', *Journal of Transportation Engineering*, vol. 118, no. 3, pp. 371-380.
- Rhodes, DL 2008, *Evolution of international aviation: phoenix rising*, 2nd edn, Ashgate Publishing, Aldershot, UK.
- Ruiz-Aguilar, JJ, Turias, IJ & Jiménez-Come, MJ 2014, 'Hybrid approaches based on SARIMA and artificial neural networks for inspection time series forecasting', *Transportation Research Part E: Logistics and Transportation Review*, vol. 67, July, pp. 1-13.
- Rumelhart, DE, Hinton, GE & Williams, RJ 1986, 'Learning internal representations by error propagation', in DE Rumelhart, GE Hinton & RJ Williams (eds), *Parallel distributed*

- processing: explorations in the microstructure of cognition: foundations*, MIT Press, Cambridge, MA, pp. 318-362.
- Ryan, P 2012, Air Australia grounded and placed into administration, *ABC News Online*, 17 February [online], viewed 29 March 2014, <<http://www.abc.net.au/news/2012-02-17/air-australia-grounded/3835244?section=qld>>
- Saad, M.M., Dao, D.M., McAndrew, R.O., & Watt, S. 1983, 'Demand for air passenger travel in Australia', *Papers of the 8th Australian Transport Research Forum 1983*, vol. 3
- Santos, AAP, Junkes, LN & Pires Jr, FCM 2014, 'Forecasting period charter rates of VLCC tankers through neural networks: a comparison of alternative approaches', *Maritime Economics & Logistics*, vol. 16, no. 1, pp. 72-91.
- Sarames, G 1972, 'World air travel demand: 1950-1980', *Journal of Travel Research*, vol. 11, no. 4, pp. 8-12.
- Sarkar, S, Chowdhury, R, Das R, Chakrabortya, S, Choib, H & Bhattacharjeeet, C 2014, 'Application of ANFIS model to optimise the photocatalytic degradation of chlorhexidine digluconate', *RSC Advances*, vol. 4, no. 40, pp. 21141-21150.
- Scarpel, RA 2013, 'Forecasting air passengers at São Paulo International Airport using a mixture of local experts model', *Journal of Air Transport Management*, vol. 26, January, pp. 35-39.
- Schott, J & Kalita, J 2011, 'Neuro-fuzzy time series analysis of large volume data', *Intelligent Systems in Accounting, Finance and Management*, vol. 18, no. 1, pp. 39-57.
- Seddighi, H. 2011, *Introductory econometrics: a practical approach*, Routledge, New York.
- Sen, A 1985, 'Examining air travel demand using time series data', *Journal of Transportation Engineering*, vol. 111, no.2, pp.155–161.
- Senvar, O, Ulutagay, G & Bekar, ET 2013, 'Forecasting oil consumption of Turkey using adaptive neuro-fuzzy inference system (ANFIS)', in C Huang & C Kahraman (eds), *Intelligent systems and decision making for risk analysis and crisis response*, CRC Press/Balkema, Leiden, The Netherlands, pp. 375-382.
- Shaw, S 2011, *Airline marketing and management*, 7th edn, Ashgate Publishing, Farnham, UK.
- Shmueli, G 2010, 'To Explain or to Predict?', *Statistical Science*, vol. 25, no. 3, pp. 289–310
- Singapore Government News 2012, 'Tiger Airways offers 30,000 airfare 30% off regular fare', 4 October.
- Sineglazov, V, Chumachenko, E & Gorbatyuk, V 2013, 'An algorithm for solving the problem of forecasting', *Aviation*, vol. 17, no. 1, pp. 9-13.
- Sinha, D 2001, *Deregulation and liberalization of the airline industry: Asia, Europe, North America, and Oceania*, Ashgate Publishing, Aldershot, UK.

- Sivrikaya, O & Tunç, E 2013, 'Demand forecasting for domestic air transportation in Turkey', *The Open Transportation Journal*, vol. 7, pp. 20-26.
- Smith, GE & Ragsdale, CT 2010, 'A deterministic approach to small data set partitioning for neural networks', in KD Lawrence & RK Klimberg (eds), *Advances in business and management forecasting*, Emerald Group Publishing, Bingley, UK, pp. 157-170.
- Sobie, B 2009, 'Asia to fuel Jetstar's expansion', *Airline Business*, vol. 25, no. 11, p. 22.
- Song, H & Li, G 2008, 'Tourism demand modelling and forecasting—A review of recent research', *Tourism Management*, vol. 29, no. 2, p. 203-220.
- Starkie, D 2008, *Aviation markets: studies in competition and regulatory reform*, Ashgate Publishing, Aldershot, UK.
- Stock, JH & Watson MW 2003, *Introduction to Econometrics*, Addison Wesley, Boston, MA.
- Svalina, I, Galzina, V, Lujčić, R & Šimunović, G 2013, 'An adaptive network-based fuzzy inference system (ANFIS) for the forecasting: the case of close price indices', *Expert Systems with Applications*, vol. 40, no. 15, pp. 6055-6063.
- Tamizharasi, G, Kathiresan, S & Sreenivasan, K.S 2014, 'Energy forecasting using artificial neural networks', *International Journal of Advanced Research in Electrical, Electronics and Instrumentation Engineering*, vol. 3, no. 3, pp.7568-7576.
- Takagi, T & Sugeno, M 1985, 'Fuzzy identification system of systems and its application to modelling and control', *IEEE Transactions Systems, Man and Cybernetics*, vol. 15, no. 1, pp. 116-132.
- Taylor, E 2013, 'Virgin Australia's rule of attraction', *Airline Business*, vol. 29, no. 6, p. 12.
- Terzic, E, Terzic, J, Nagarajah, R & Alamgir, M 2012, *A neural network approach to fluid quantity measurement in dynamic environments*, Springer-Verlag, London.
- Thanasupsin, K, Chaichana, S & Pliankarom, S 2010, 'Factors influencing mode selections of low-cost carriers and a full-service airline in Thailand', *Transportation Journal*, vol. 49, no. 1, pp. 35-47.
- The Saigon Times Daily 2003, Jetstar order Airbus A320 for low cost carrier fleet. 23 December, p. 1.
- Thomas, G 2004, 'Jetstar ups the ante in fare wars', *Weekend Australian*, 02 October, p. 3.
- Thomas, G 2006a, 'Tiger on the prowl', *Air Transport World*, vol. 43, no. 5, pp. 46-48.
- Thomas, G 2006b, 'Taking care of business', *Air Transport World*, vol. 43, no. 10, pp. 54-58.
- Thomas, G 2007, 'Jetting to the top', *Air Transport World*, vol. 44, no. 11, pp. 57-60.
- Thomas, I 2000, 'Better late than never', *Air Transport World*, vol. 37, no. 11, pp. 76-77.
- Thomas, I 2003, 'After the honeymoon', *Air Transport World*, vol. 40, no. 10, pp. 28-31.

Tiger Airways 2012a, *Tiger Airways operating statistics for the month of April 2012*, viewed 27 March 2014,
<http://www.tigerair.com/news/TH_20120514_Tiger_Airways_Operating_Statistics_for_the_Month_of_April_2012.pdf>

Tiger Airways 2012b, *Tiger Airways operating statistics for the month of May 2012*, viewed 27 March 2014,
<http://www.tigerair.com/news/TH_20120611_Tiger_Airways_Operating_Statistics_for_the_Month_of_May_2012.pdf>

Tiger Airways 2012c, *Tiger Airways operating statistics for the month of June 2012*, viewed 27 March 2014,
<http://www.tigerair.com/news/TH_20120710_Tiger_Airways_Operating_Statistics_for_the_Month_of_June_2012.pdf>

Tiger Airways 2012d, *Tiger Airways operating statistics for the month of July 2012*, viewed 27 March 2014,
<http://www.tigerair.com/news/TH_20120810_Tiger_Airways_Operating_Statistics_for_July_2012.pdf>

Tiger Airways 2012e, *Tiger Airways operating statistics for the month of August 2012*, viewed 27 March 2014,
<http://www.tigerair.com/news/TH_20120910_Tiger_Airways_Operating_Statistics_for_August_2012.pdf>

Tiger Airways 2012f, *Tiger Airways operating statistics for the month of September 2012*, viewed 27 March 2014,
<http://www.tigerair.com/news/TH_20121011_Sep_12_Operating_Statistics.pdf>

Tiger Airways 2012g, *Tiger Airways operating statistics for the month of October 2012*, viewed 27 March 2014,
<http://www.tigerair.com/news/TH_20121112_Oct_2012_Operating_Statistics.pdf>

Tiger Airways 2012h, *Tiger Airways operating statistics for the month of November 2012*, viewed 27 March 2014,
<http://www.tigerair.com/news/OS_20121210_Nov_2012_Operating_Statistics.pdf>

Tiger Airways 2013a, *Tiger Airways operating statistics for the month of December 2012*, viewed 27 March 2014,
<http://www.tigerair.com/news/TH_20130111_Tiger_Airways_Operating_Statistics_Dec_2012.pdf>

Tiger Airways 2013b, *Tiger Airways operating statistics for the month of January 2013*, viewed 27 March 2014,
<http://www.tigerair.com/news/TH_20130218_Tiger_Airways_Operating_Statistics_Jan_2013.pdf>

Tiger Airways 2013c, *Tiger Airways operating statistics for the month of February 2013*, viewed 27 March 2014,
<http://www.tigerair.com/news/TH_20130813_Tiger_Airways_Operating_Statistics_Feb_2013.pdf>

Tiger Airways 2013d, *Tiger Airways operating statistics for the month of March 2013*, viewed 27 March 2014,

<http://www.tigerair.com/news/TH_20130813_Tiger_Airways_Operating_Statistics_Mar_2013.pdf>

Tiger Airways 2013e, *Tiger Airways operating statistics for the month of April 2013*, viewed 27 March 2014,
<http://www.tigerair.com/news/TH_20130813_Tiger_Airways_Operating_Statistics_Apr_2013.pdf>

Tiger Airways 2013f, *Tiger Airways operating statistics for the month of May 2013*, viewed 27 March 2014,
<http://www.tigerair.com/news/TH_20130813_Tiger_Airways_Operating_Statistics_May_2013.pdf>

Tiger Airways 2013g, *Tiger Airways operating statistics for the month of June 2013*, viewed 27 March 2014,
<http://www.tigerair.com/news/TH_20130813_Tigerair_Operating_Statistics_Jun13.pdf>

Tiger Airways 2014a, Tigerair's affordable fares now available via Amadeus travel agencies, viewed 15 June 2014,
<http://www.tigerair.com/news/TH_20140113_Tigerair_affordable_fares_now_available_via_Amadeus_final.pdf>

Tiger Airways 2014b, About us: Tigerair story, viewed 15 June 2014,
<http://www.tigerair.com/au/en/about_us.php>

Tiger Airways 2014c, *Tigerair launches infrequent flyer club*, Media Release 8 April, viewed 15 June 2014,
<http://www.tigerair.com/news/TT_20140408_20140408.pdf>

Tiger Airways 2014d, *Where we fly*, viewed 27 March 2014,
<http://www.tigerair.com/au/en/destination_map.php>

Tiger Airways Holdings 2014a, *About us: Tigerair story*, viewed 26 August 2014,
<http://www.tigerair.com/au/en/about_us.php>.

Tiger Airways Holdings 2014b, *Fees and charges*, viewed 26 August 2014,
<<http://www.tigerair.com/au/en/fees2.php>>.

Tiryaki, S & Aydın, A 2014, 'An artificial neural network model for predicting compression strength of heat treated woods and comparison with a multiple linear regression model', *Construction and Building Materials*, vol. 62, 15 July, pp. 102-108.

Tiwari, MK, Bajpai, S & Dewangan, UK 2012, 'Prediction of industrial solid waste with ANFIS Model and its comparison with ANN Model – a case study of Durg-Bhilai Twin City India', *International Journal of Engineering and Innovative Technology*, vol. 2, no. 6, pp. 192-201.

Tomová, A & Ramajová, L 2014, 'Frequent flyer programs and low-cost airlines: ongoing hybridization?', *Procedia - Social and Behavioral Sciences*, vol. 110, 24 January, pp. 787–795

Toshinori, M, 1998, *Fundamentals of the new artificial intelligence*, Springer, New York.

Tsekeris, T 2009, 'Dynamic analysis of air travel demand in competitive island markets', *Journal of Air Transport Management*, vol. 15, no. 6, pp. 267-273.

Tso, GKF & Yau, KKW 2007, 'Predicting electricity energy consumption: a comparison of regression analysis, decision tree and neural networks', *Energy*, vol. 32, no. 9, pp. 1761-1768.

Übeyli, ED, Cvetkovic, D, Holland, G & Cosic, I 2010, 'Adaptive neuro-fuzzy inference system employing wavelet coefficients for detection of alterations in sleep EEG activity during hypopnoea episodes', *Digital Signal Processing*, vol. 20, no. 3, pp. 678-691.

Uddin, W, McCullough, BF, & Crawford, MM 1985, 'Methodology for forecasting air travel and airport expansion needs', *Transportation Research Record*, no. 1025, pp. 7-14.

Vasigh, B, Tacker, T & Fleming, K 2008, *Introduction to air transport economics: from theory to applications*, Ashgate Publishing, Aldershot, UK.

Vasigh, B, Fleming, K & Tacker, T 2013, *Introduction to air transport economics: from theory to applications*, 2nd edn, Ashgate Publishing, Farnham, UK.

Venkatesh, K, Ravi, V, Prinzie, A & Van den Poel, D 2014, 'Cash demand forecasting in ATMs by clustering and neural networks', *European Journal of Operational Research*, vol. 232, no. 2, pp. 383-392.

Vidović, A, Štimac, I & Vince, D 2013, 'Development of business models of low-cost airlines', *International Journal for Traffic and Transportation Engineering*, vol. 3, no. 1, pp. 69-81.

Virgin Australia 2011a, *Virgin Australia annual report 2011*, viewed 21 December 2013, <<http://www.virginaustralia.com/cs/groups/internetcontent/@wc/documents/webcontent/~edisp/annual-rpt-2011.pdf>>

Virgin Australia 2011b, *Virgin Australia re-brands its international airlines*, Press Release 7 December, viewed 3 May 2014, <<http://www.virginaustralia.com/au/en/about-us/media/2011/VIRGIN-AUSTRALIA-RE-BRANDS/>>

Virgin Australia 2012, *Virgin Australia annual report 2012*, viewed 21 December 2013, <<http://www.virginaustralia.com/cs/groups/internetcontent/@wc/documents/webcontent/~edisp/annual-rpt-2012.pdf>>

Virgin Australia 2013, *Virgin Australia annual report 2013*, viewed 21 December 2013, <<http://www.virginaustralia.com/cs/groups/internetcontent/@wc/documents/webcontent/~edisp/annual-rpt-2013.pdf>>

Virgin Blue 2004, *Virgin Blue annual report 2004*, viewed 21 December 2013, <<http://www.virginaustralia.com/cs/groups/internetcontent/@wc/documents/webcontent/~edisp/annual-rpt-2004-a3.pdf>>

Virgin Blue 2005, *Virgin Blue annual report 2005*, viewed 21 December 2013, <<http://www.virginaustralia.com/cs/groups/internetcontent/@wc/documents/webcontent/~edisp/annual-rpt-2005.pdf>>

Virgin Blue 2006a, *Virgin Blue annual report 2006*, viewed 21 December 2013, <<http://www.virginaustralia.com/cs/groups/internetcontent/@wc/documents/webcontent/~edisp/annual-rpt-2006.pdf>>

- Virgin Blue 2006b, *Virgin Blue orders 20 Embraer 'E-Jets' - New fleet strategy for Australia's 'New World Carrier'*, Press Release November 2 [online], viewed 3 May 2014, <http://www.virginaustralia.com/au/en/about-us/media/2006/VB_ORDERS_20_EMBRAER_JETS/>
- Virgin Blue 2007, *Virgin Blue annual report 2007*, viewed 21 December 2013, <<http://www.virginaustralia.com/cs/groups/internetcontent/@wc/documents/webcontent/~edisp/annual-rpt-2007.pdf>>
- Virgin Blue 2008, *The report: annual report 2008*, viewed 21 December 2013, <<http://www.virginaustralia.com/cs/groups/internetcontent/@wc/documents/webcontent/~edisp/annual-rpt-2008.pdf>>
- Virgin Blue 2009, *The report: annual report 2009*, viewed 21 December 2013, <<http://www.virginaustralia.com/cs/groups/internetcontent/@wc/documents/webcontent/~edisp/annual-rpt-2009.pdf>>
- Virgin Blue Holdings 2010, *Virgin Blue Holdings annual report 2010*, viewed 21 December 2013, <<http://www.virginaustralia.com/cs/groups/internetcontent/@wc/documents/webcontent/~edisp/annual-rpt-2010.pdf>>
- Wadud, Z 2011, 'Modelling and forecasting passenger demand for a new domestic airport with limited data', *Transportation Research Record: Journal of the Transportation Research Board*, vol. 2214, pp. 59-68.
- Wang, M & Song, H 2010, 'Air travel demand studies: a review', *Journal of China Tourism Research*, vol. 6, no. 1, pp. 29-49.
- Waters, D 2014, *Quantitative methods for business*, 4th edn, Content Technologies.
- Watts, MJ & Worner, SP 2008, 'Using artificial neural networks to determine the relative contribution of abiotic factors influencing the establishment of insect pest species', *Ecological Informatics*, vol. 3, no. 1, pp. 64-74.
- Wei, LY 2013, 'A GA-weighted ANFIS model based on multiple stock market volatility causality for TAIEX forecasting', *Applied Soft Computing*, vol.13, no. 2, pp. 911-920.
- Wei, LY, Chen, TL & Ho, TH 2011, 'A hybrid model based on adaptive-network-based fuzzy inference system to forecast Taiwan stock market', *Expert Systems with Applications*, vol. 38, no. 11, pp. 13625-13631.
- Wensveen, JG 2011, *Air transportation: a management perspective*, 7th edn, Ashgate Publishing, Farnham, UK.
- Wensveen, JG & Leick, R 2009, 'The long-haul low-cost carrier: a unique business model', *Journal of Air Transport Management*, vol.15, no. 3, pp. 127-133.
- Whyte, R, Prideaux, B & Sakata, H 2012, 'The evolution of Virgin Australia from a low-cost carrier to a full-service airline – implications for the tourism industry', in JS Chen (ed), *Advances in hospitality and leisure*. Volume 8, Emerald Group Publishing, Bingley, UK, pp. 215-231.

- Wieland, D, Wotawa, F & Wotawa, G 2002, 'From neural networks to qualitative models in environmental engineering', *Computer-Aided Civil Infrastructure Engineering*, vol. 17, no. 2, pp.104-118.
- Wilkinson, N 2005, *Managerial economics: a problem-solving approach*, Cambridge University Press, Cambridge, UK.
- Wilson, ID, Paris, SD, Ware, JA & Jenkins, DH 2002, 'Residential property price time series forecasting with neural networks', in A Macintosh, M Moulton & A Preece (eds), *Applications and innovations in intelligent systems IX: Proceedings of ES2001 the Twenty First SGES International Conference on Knowledge based Systems and Artificial Intelligence*, Springer-Verlag, London, pp. 17-28.
- Wu, CL 2010, *Airline operations and delay management: insights from airline economics, networks and strategic schedule planning*, Ashgate Publishing, Farnham, UK.
- Xiao, Y, Liu, JJ, Hu, Y, Wang, Y, Keung Lai, K & Wang, S 2014, 'A neuro-fuzzy combination model based on singular spectrum analysis for air transport demand forecasting', *Journal of Air Transport Management*, vol. 39, July, pp. 1-11.
- Yager, R & Filev, D 1994, 'Generation of fuzzy rules by mountain clustering', *Journal of Intelligent and Fuzzy Systems*, vol. 2, no. 3, pp. 209-219.
- Yan, H, Zou, Z & Wang, H 2010, 'Adaptive neuro fuzzy inference system for classification of water quality status', *Journal of Environmental Sciences*, vol. 22, no. 12, pp. 1891-1896.
- Yetilmezsoy, K, Fingas, M & Fieldhouse, B 2011, 'An adaptive neuro-fuzzy approach for modelling of water-in-oil emulsion formation', *Colloids and Surfaces A: Physicochemical and Engineering Aspects*, vol. 389, no. 1-3, pp. 50-62.
- Yeung, DS, Cloete, L, Shi, D & Ng, WWY 2010, *Sensitivity analysis for neural networks*, Springer, Berlin Heidelberg.
- Yilmaz, I & Kaynar, O 2011, 'Multiple regression, ANN (RBF, MLP) and ANFIS models for prediction of swell potential of clayey soils', *Expert Systems with Applications*, vol. 38, no. 5, pp. 5958–5966.
- Young, SB & Wells, AT 2011, *Airport planning and management*, 6th edn, McGraw-Hill, New York.
- Zahedi, G, Azizi, S, Bahadori, A, Elkamel, A & Wan Alwi, SR 2013, 'Electricity demand estimation using an adaptive neuro-fuzzy network: a case study from the Ontario province – Canada', *Energy*, vol. 49, no. 1, pp. 323-328.
- Zhang, GP 2003, 'Time series forecasting using a hybrid ARIMA and neural network model', *Neurocomputing*, vol. 50, January, pp. 159-175.
- Zhang, GP 2004, 'A combined ARIMA and neural network approach for time series forecasting', in GP Zhang (ed), *Neural networks in business forecasting*, Idea Group Publishing, Hershey, PA, pp. 213-225.
- Zhang, GP, Patuwo, BE & Hu, MY 1998, 'Forecasting with artificial neural networks: the state of the art', *International Journal of Forecasting*, vol. 14, no. 1, pp. 35-62.

APPENDIX 1 EXAMINATION OF THE HYBRIDIZATION AUSTRALIA'S LCCs BUSINESS MODEL DOCUMENT SOURCES

Table A1. The document selected and data analysis for Australia's LCCs business model

Month/Year	Document selected	Data Analysis
December 2003	Jetstar orders Airbus A320 for low-cost carrier fleet. (The Saigon Times Daily Ho Chi Minh City, 23 Dec 2003)	Details of Jetstar ordered A320s from Airbus A320.
May 2004	Qantas data book 2013	Jetstar commenced operations in Australia in 2004.
October 2004	Jetstar ups the ante in fare wars. (Weekend Australian, 2 October 2004)	Jetstar announced conditional internet \$49 one-way fares. And it will move to an all-A320 fleet by mid-2006, which will number 23 aircraft and our A320 program remains on track.
Jan 2005	Jetstar joins the Adelaide air fare war (The Advertiser, Adelaide, S. Aust, 29 Jan 2005)	Compare Adelaide's airfare between Jetstar and competitors. Details of boarding card types.
May 2005	Jetstar winning blue with (The Australian Canberra, A.C.T 13 May 2005)	Analyse Jetstar business strategy.
March 2006	Jetstar set for Perth (Herald Sun, Melbourne, Vic, 27 Mar 2006)	Jetstar launched flights to Perth and adding services to Sydney and Adelaide.
August 2006	Jetstar cabin crew to lead AWAs (The Australian Canberra, A.C.T, 14 Aug 2006)	Analyse Jetstar employment policy.
November 2006	In-Flight Entertainment (Avionics Magazine, November 2006)	Jetstar chose digEcor's digEplayer XT for its new Airbus A330-200s.
November 2006	Qantas data book 2013	Jetstar Long haul international flying commenced on 23 November 2006.
February 2007	Tiger Airways Licks Chops At Australia	Tiger airways announced to be low-cost and very low-fare airline.

	(Wall Street Journal, Eastern edition, New York, N.Y, 14 Feb 2007)	
February 2007	Tiger eyes off Aussie airways (Townsville Bulletin, Townsville, Qld, 10 Feb 2007)	Tiger Airways Australia plan to offer domestic fares of less than \$10 a route by the end of 2007.
August 2007	Jetstar plans 'very large' A320 order (Flight International, Jul 31-Aug 6, 2007)	Qantas ordered 9 additional A320s for Jetstar.
February 2008	No-Luggage Break Cuts Qantas Low-Cost Fares. (Flight International, Feb 19-Feb 25, 2008)	Jetstar offered a discount to passengers who have no check-in luggage.
August 2008	Tiger Airways announces new flights from Adelaide (AAP Finance News Wire, Sydney, 28 Aug 2008)	Tiger Airways announced new flights from Adelaide to Hobart, the Gold Coast, Perth and Alice Springs.
April 2009	Sagging sales put A380s on back burner at Qantas. (Flight International, Apr 21-Apr 27, 2009)	Jetstar will manage wage costs by employing a slew of initiatives such as annual leave, long service leave.
October 2009	Jetstar accelerates A320 deliveries (Flight International, Oct 13-Oct 19, 2009)	The other five A320s to be delivered before the end of March will be go to its Singapore arm Jetstar Asia.
December 2009	Jetstar to charge for 'up front' seats (australianaviation.com.au, December 21 2009)	Jetstar announced 'Up Front Seating', an option of selecting a seat in the first three rows of the aircraft for an additional charge.
June 2010	Jetstar interlines with Air France-KLM, (australianaviation.com.au, June 2 2010)	Jetstar interlines with Air France-KLM.
September 2010	iPAD offers new choice for in-flight entertainment, (Flight International, Sep 7-Sep 13, 2010)	Jetstar Airways made headlines in June when it announced plans to become the first airline to rent iPads as in-flight entertainment.
January 2011	Jetstar teams up with oneworld, Finnair,	Jetstar teams up with oneworld, Finnair.

	(australianaviation.com.au, January 28 2011]	
May 2011	Jetstar offer self service kiosks and web check-in offering for passengers. (australianaviation.com.au May 2011)	Jetstar offered self service kiosks and web check-in offering for passengers.
May 2011	Jetstar takes fare bundling to the Max, (Australianaviation.com.au, May 17 2011)	Jetstar takes fare bundling to the Max.
February 2012	Jet and Jetstar to interline, (Australianaviation.com.au, February 24 2012)	Jet and Jetstar to interline.
June 2012	iPads Help Some Airlines Cut Costs (Business Week, Jun 11, 2012)	Jetstar offered iPads for \$10-\$15 on flights over two hours.
June 2012	Tiger Airways Half Price Sale on Now (Singapore Government News New Delhi: Athena Information Solutions Pvt. Ltd. Jun 6, 2012)	Tiger Airways offered domestic half-price sale.
July 2012	Tiger Airways Latest Sale Features Fares on Popular Routes from \$39.95 (Singapore Government News New Delhi: Athena Information Solutions Pvt. Ltd., Jul 25, 2012)	Tiger Airways Australia is gearing up for the commencement of its Sydney - Brisbane service by offering one way fares from \$54.95* on the new route.
October 2012	Tiger Airways Offers 30,000 Airfares for 30% Off Regular Fare (Singapore Government News New Delhi: Athena Information Solutions Pvt. Ltd., Oct 4, 2012)	Tiger Airways Australia offered 30% off the regular Tiger "Raw" domestic fares.
September 2013	Qantas, Jetstar get nod from competition regulator. (The Business Times [Singapore] 24 Sep 2013)	Qantas and Jetstar have been establishing joint ventures in a number of Asian markets together with local airline partners which so called pan-Asia strategy.
December 2013	Jetstar to stay at Avalon until 2015, (Australianaviation.com.au, December 11 2013)	Jetstar to stay at Avalon until 2015.
January 2014	Tigerair affordable fares now	Tigerair collaborated with Amadeus, a

	available via Amadeus. (Tigerair.com January 2014)	leading technology partner for the global travel industry, which will strengthen their distribution channel.
February 2014	Emirates and Jetstar to codeshare. (australianaviation.com.au February 2014)	Emirates and Jetstar operated codeshare.
March 2014	Tigerair launches web check. (Australianaviation.com.au, March 11 2014)	Tigerair launches web check.
April 2014	Tigerair Australia launched Infrequent Flyer program. (Tigerair.com, April 2014)	Tigerair Australia launched Infrequent Flyer Club on April 8 2014.

Note: The abovementioned documents relate to the analysis of the hybridization of Australia's domestic LCCS as presented in Section 3.4.

APPENDIX 2 MATLAB CODE FOR THE GENETIC ALGORITHM

APPENDIX 2.1 Matlab Code for GAPAXDE and GARPksDE (Linear Form)

```

clear

%%%%%%%%%%%%%%%%%%%%%%%%%%%%%%%%%%%%%%%%%%%%%%%%%%%%%%%%%%%%%%%%%%%%%%%% User Inputs %%%%%%%%%%%%%%%%%%%%%%%%%%%%%%%%%%%%%%%%%%%%%%%%%%%%%%%%%%%%%%%%%%%%%%%%%
% V = Index to specify the dependent variable being modelled (i.e. V=1 for
PAX and V=2 for RPK).
V=1;
% K = Desired number of factors to include in the multi-linear model.
K=11;
% M = size of the population of solutions used in the genetic algorithm.
M=1000;
% Mutation Rate
mu_rate=0.01;
% Number to Breed
PB=200;
% Number of new/migrating Members
PM=50;
GA_cycles = 200; % This could be replaced with a tolerance termination
condition.
%%%%%%%%%%%%%%%%%%%%%%%%%%%%%%%%%%%%%%%%%%%%%%%%%%%%%%%%%%%%%%%%%%%%%%%%

if PB+PM>=M
    display('Invalid choice of PB and PM.')
    break
end

if PB*PM==0
    display('Invalid choice of PB and PM.')
    break
end

% Load the data file.
data=xlsread('dataGA.xlsx');
[m,n]=size(data);

% Initialisation the population.
P=zeros(M,n-2);
for i=1:M
    total=0;
    while total<K
        u=ceil((n-2)*rand(1));
        P(i,u)=1;
        total=sum(P(i,:));
    end
end

% Perform MLR on each member of the initial population
SS=zeros(M,1);
for i=1:M
    Y=data(:,V);
    X=ones(m,K+1);
    filled=1;

```

```

j=0;
while filled<K+1
    j=j+1;
    if P(i,j)==1
        filled=filled+1;
        X(:,filled)=data(:,j+2);
    end
end
beta=inv(X'*X)*X'*Y;
% sum of squares
Y_est=X*beta;
SS(i)=sum((Y-Y_est).^2);
end

% Rank the population
P_sort=zeros(M,n-2);
SS_sort=zeros(M,1);
for i=1:M
    [min_val,min_index]=min(SS);
    P_sort(i,:)=P(min_index,:);
    SS_sort(i)=min_val;
    SS(min_index)=10^100;
end
display(SS_sort(1))

% Genetic Algorithm
for GA=1:GA_cycles
    display(GA)
    % Calculate selection and elimination probabilities for the current
    % population.
    SS_inverse=zeros(M,1);
    for i=1:M
        SS_inverse(i)=1/SS_sort(i);
    end
    SS_Inv_Tot=sum(SS_inverse);
    Prob_Select=zeros(M,1); % Cumulative Probabilities for selecting a
    population member for breeding
    for i=1:M
        Prob_Select(i)=sum(SS_inverse(1:i))/SS_Inv_Tot;
    end
    SS_Total=sum(SS_sort(2:M));
    Prob_Eliminate=zeros(M,1);
    for i=2:M
        Prob_Eliminate(i)=sum(SS_sort(2:i))/SS_Total; % Cumulative
        Probabilities for eliminating a population member to make way for migration
        and new generation.
    end

    if PB>=1
        % Breed New Solutions.
        P_Bred=zeros(PB,n-2);
        for i=1:PB
            % Select Parents
            u1=rand(1);
            index1=1;
            while u1>Prob_Select(index1)
                index1=index1+1;
            end
            Parent_1=P_sort(index1,:);
        end
    end
end

```

```

u2=rand(1);
index2=1;
while u2>Prob_Select(index2)
    index2=index2+1;
end
if index1==index2 % Avoid selecting the same parent twice. If
possible choose the adjacent better parent, however if the best parent is
already chosen then choose the next worst.
    if index1~=1
        index2=index1-1;
    else
        index2=index1+1;
    end
end
end
Parent_2=P_sort(index2,:);
% Perform the gene crossing.
P_sum=(Parent_1+Parent_2)/2;
P_new=zeros(1,n-2);
for j=1:n-2
    if P_sum(j)==1
        P_new(j)=1;
    end
end
j=-1;
while sum(P_new)<K
    j=j+1;
    index=mod(j,n-2)+1;
    if P_sum(index)==0.5 && rand(1)<0.5
        P_new(index)=1;
    end
end
P_Bred(i,:)=P_new;
end
% Evaluate LS for each bred member
SS_Bred=zeros(PB,1);
for i=1:PB
    Y=data(:,V);
    X=ones(m,K+1);
    filled=1;
    j=0;
    while filled<K+1
        j=j+1;
        if P_Bred(i,j)==1
            filled=filled+1;
            X(:,filled)=data(:,j+2);
        end
    end
    beta=inv(X'*X)*X'*Y;
    % sum of squares
    Y_est=X*beta;
    SS_Bred(i)=sum((Y-Y_est).^2);
end
end
% Introduce some new members
if PM>=1
    P_migrate=zeros(PM,n-2);
    for i=1:PM
        total=0;
        while total<K
            u=ceil((n-2)*rand(1));

```



```

        P_migrate(i,u)=1;
        total=sum(P_migrate(i,:));
    end
end
% Evaluate LS for each new member
SS_migrate=zeros(PM,1);
for i=1:PM
    Y=data(:,V);
    X=ones(m,K+1);
    filled=1;
    j=0;
    while filled<K+1
        j=j+1;
        if P_migrate(i,j)==1
            filled=filled+1;
            X(:,filled)=data(:,j+2);
        end
    end
    beta=inv(X'*X)*X'*Y;
    % sum of squares
    Y_est=X*beta;
    SS_migrate(i)=sum((Y-Y_est).^2);
end
end
% Eliminate Existing members of P_sort - This will get slow if we are
% eliminating too many.
Elim_Index_Set=zeros(M,1);
total=0;
while total<PB+PM
    u=rand(1);
    index=2;
    while u>Prob_Eliminate(index)
        index=index+1;
    end
    if Elim_Index_Set(index)==0
        Elim_Index_Set(index)=1;
        total=total+1;
    end
end
count=0;
for i=1:M
    if Elim_Index_Set(i)==1
        count=count+1;
        if count<=PB
            P_sort(i,:)=P_Bred(count,:);
            SS_sort(i,:)=SS_Bred(count,:);
        else
            P_sort(i,:)=P_migrate(count-PB,:);
            SS_sort(i,:)=SS_migrate(count-PB,:);
        end
    end
end
P=P_sort;
SS=SS_sort;
% Rank the population
P_sort=zeros(M,n-2);
SS_sort=zeros(M,1);
for i=1:M
    [min_val,min_index]=min(SS);
    P_sort(i,:)=P(min_index,:);
end

```

```

        SS_sort(i)=min_val;
        SS(min_index)=10^100;
    end
    display(SS_sort(1))
end

% Determine beta values for best solution.
Y=data(:,V);
X=ones(m,K+1);
filled=1;
j=0;
while filled<K+1
    j=j+1;
    if P_sort(1,j)==1
        filled=filled+1;
        X(:,filled)=data(:,j+2);
    end
end
beta=inv(X'*X)*X'*Y;
% sum of squares
Y_est=X*beta;

% Final output display:
display('Minimum Least Squares Value')
display(SS_sort(1))
display('Variables included in the model (1 = included, 0 = not included)')
display(P_sort(1,:))
display('Coefficients of the linear model. The first number is the
constant, while the subsequent numbers are the variable coefficients.')
display(beta)

% Test - Output a matrix A showing the actual values in the first column
and the predicted values in the second column.
A=zeros(m,3);
A(:,1)=data(:,V);
for j=1:m
    A(j,2)=beta(1);
    count=1;
    for i=1:n-2
        if P_sort(1,i)==1
            count=count+1;
            A(j,2)=A(j,2)+beta(count)*data(j,i+2);
        end
    end
end
end

% Percentage Errors
for i=1:m
    A(i,3)=abs(A(i,1)-A(i,2))/A(i,1)*100;
end
display('Actual values of DV in column 1, predicted values of DV in column
2, absolute percentage error in column 3.')
display(A)
display('Average Percentage Error')
display(sum(A(:,3))/m)

```

APPENDIX 2.2 Matlab Code for GAPAXDE and GARPkSDE (Quadratic form)

```

clear

%%%%%%%%%%%%%%%%%%%%%%%%%%%%%%%%%%%%%%%%%%%%%%%%%%%%%%%%%%%%%%%%%%%%%%%%%% User Inputs %%%%%%%%%%%%%%%%%%%%%%%%%%%%%%%%%%%%%%%%%%%%%%%%%%%%%%%%%%%%%%%%%%%%%%%%%%%
% V = Index to specify the dependent variable being modelled (i.e. V=1 for
PAX and V=2 for RPK).
V=1;
% K = Desired number of factors to include in the multi-linear model.
K=7;
% M = size of the population of solutions used in the genetic algorithm.
M=1000;
% Mutation Rate
mu_rate=0.01;
% Number to Breed
PB=200;
% Number of new/migrating Members
PM=50;
GA_cycles = 200; % This could be replaced with a tolerance termination
condition.
%%%%%%%%%%%%%%%%%%%%%%%%%%%%%%%%%%%%%%%%%%%%%%%%%%%%%%%%%%%%%%%%%%%%%%%%%%

if PB+PM>=M
    display('Invalid choice of PB and PM.')
    break
end

if PB*PM==0
    display('Invalid choice of PB and PM.')
    break
end

% Load the data file.
data=xlsread('dataGA.xlsx');
[m,n]=size(data);

% Specify an adjusted number of variables given the quadratic terms.
nq=n+0.5*(n-2)*(n-1);

% Initialisation the population.
P=zeros(M,nq-2);
for i=1:M
    total=0;
    while total<K
        u=ceil((nq-2)*rand(1));
        P(i,u)=1;
        total=sum(P(i,:));
    end
end

% Perform MLR on each member of the initial population
SS=zeros(M,1);
for i=1:M
    Y=data(:,V);
    X=ones(m,K+1);
    filled=1;
    j=0;
    while filled<K+1

```

```

j=j+1;
if P(i,j)==1
    filled=filled+1;
    indices=f(j,n);
    if size(indices,2)==1
        if indices~=j
            display('f is not returning the correct index')
        end
        X(:,filled)=data(:,indices+2);
    else
        X(:,filled)=data(:,indices(1)+2).*data(:,indices(2)+2);
    end
end
end
beta=inv(X'*X)*X'*Y;
% sum of squares
Y_est=X*beta;
SS(i)=sum((Y-Y_est).^2);
if isnan(SS(i))
    SS(i)=10^99;
end
end

% Rank the population
P_sort=zeros(M,nq-2);
SS_sort=zeros(M,1);
for i=1:M
    [min_val,min_index]=min(SS);
    P_sort(i,:)=P(min_index,:);
    SS_sort(i)=min_val;
    SS(min_index)=10^100;
end
display(SS_sort(1))

% Genetic Algorithm
for GA=1:GA_cycles
    display(GA)
    % Calculate selection probabilities for the current
    % population.
    SS_inverse=zeros(M,1);
    for i=1:M
        SS_inverse(i)=1/SS_sort(i);
    end
    SS_Inv_Tot=sum(SS_inverse);
    Prob_Select=zeros(M,1); % Cumulative Probabilities for selecting a
    population member for breeding
    for i=1:M
        Prob_Select(i)=sum(SS_inverse(1:i))/SS_Inv_Tot;
    end
    if PB>=1
        % Breed New Solutions.
        P_Bred=zeros(PB,nq-2);
        for i=1:PB
            % Select Parents
            u1=rand(1);
            index1=1;
            while u1>Prob_Select(index1)
                index1=index1+1;
            end
            Parent_1=P_sort(index1,:);

```

```

u2=rand(1);
index2=1;
while u2>Prob_Select(index2)
    index2=index2+1;
end
if index1==index2 % Avoid selecting the same parent twice. If
possible choose the adjacent better parent, however if the best parent is
already chosen then choose the next worst.
    if index1~=1
        index2=index1-1;
    else
        index2=index1+1;
    end
end
end
Parent_2=P_sort(index2,:);
% Perform the gene crossing.
P_sum=(Parent_1+Parent_2)/2;
P_new=zeros(1,nq-2);
for j=1:nq-2
    if P_sum(j)==1
        P_new(j)=1;
    end
end
j=-1;
while sum(P_new)<K
    j=j+1;
    index=mod(j,nq-2)+1;
    if P_sum(index)==0.5 && rand(1)<0.5
        P_new(index)=1;
    end
end
end
P_Bred(i,:)=P_new;
end
% Evaluate LS for each bred member
SS_Bred=zeros(PB,1);
for i=1:PB
    Y=data(:,V);
    X=ones(m,K+1);
    filled=1;
    j=0;
    while filled<K+1
        j=j+1;
        if P_Bred(i,j)==1
            filled=filled+1;
            indices=f(j,n);
            if size(indices,2)==1
                if indices~=j
                    display('f is not returning the correct index')
                end
                X(:,filled)=data(:,indices+2);
            else
                X(:,filled)=data(:,indices(1)+2).*data(:,indices(2)+2);
            end
        end
    end
end
beta=inv(X'*X)*X'*Y;
% sum of squares
Y_est=X*beta;
SS_Bred(i)=sum((Y-Y_est).^2);

```

```

    end
end
% Introduce some new members
if PM>=1
    P_migrate=zeros(PM,nq-2);
    for i=1:PM
        total=0;
        while total<K
            u=ceil((nq-2)*rand(1));
            P_migrate(i,u)=1;
            total=sum(P_migrate(i,:));
        end
    end
    % Evaluate LS for each new member
    SS_migrate=zeros(PM,1);
    for i=1:PM
        Y=data(:,V);
        X=ones(m,K+1);
        filled=1;
        j=0;
        while filled<K+1
            j=j+1;
            if P_migrate(i,j)==1
                filled=filled+1;
                indices=f(j,n);
                if size(indices,2)==1
                    if indices~=j
                        display('f is not returning the correct index')
                    end
                    X(:,filled)=data(:,indices+2);
                else
                    X(:,filled)=data(:,indices(1)+2).*data(:,indices(2)+2);
                end
            end
        end
        beta=inv(X'*X)*X'*Y;
        % sum of squares
        Y_est=X*beta;
        SS_migrate(i)=sum((Y-Y_est).^2);
    end
end
% Eliminate Existing members of P_sort - This will get slow if we are
% eliminating too many.
Elim_Index_Set=zeros(M,1);
total=0;
while total<PB+PM
    SS_Total=sum(SS_sort(2:M).*(ones(M-1,1)-Elim_Index_Set(2:M)));
    Prob_Eliminate=zeros(M,1);
    for i=2:M
        Prob_Eliminate(i)=Prob_Eliminate(i-1)+SS_sort(i)*(1-
Elim_Index_Set(i))/SS_Total; % Cumulative Probabilities for eliminating a
population member to make way for migration and new generation.
    end
    if abs(Prob_Eliminate(M)-1)>10^(-4)
        display(Prob_Eliminate(M))
        display('Problem with Prob_Eliminate')
        pause(5)
    end
end
u=rand(1);

```

```

    index=2;
    while u>Prob_Eliminate(index)
        index=index+1;
    end
    if Elim_Index_Set(index)==0
        Elim_Index_Set(index)=1;
        total=total+1;
    end
end
count=0;
for i=1:M
    if Elim_Index_Set(i)==1
        count=count+1;
        if count<=PB
            P_sort(i,:)=P_Bred(count,:);
            SS_sort(i,:)=SS_Bred(count,:);
        else
            P_sort(i,:)=P_migrate(count-PB,:);
            SS_sort(i,:)=SS_migrate(count-PB,:);
        end
    end
end
P=P_sort;
SS=SS_sort;
% Rank the population
P_sort=zeros(M,nq-2);
SS_sort=zeros(M,1);
for i=1:M
    [min_val,min_index]=min(SS);
    P_sort(i,:)=P(min_index,:);
    SS_sort(i)=min_val;
    SS(min_index)=10^100;
end
display(SS_sort(1))
end

% Determine beta values for best solution.
Y=data(:,V);
X=ones(m,K+1);
filled=1;
j=0;
while filled<K+1
    j=j+1;
    if P_sort(1,j)==1
        filled=filled+1;
        indices=f(j,n);
        if size(indices,2)==1
            if indices~=j
                display('f is not returning the correct index')
            end
            X(:,filled)=data(:,indices+2);
        else
            X(:,filled)=data(:,indices(1)+2).*data(:,indices(2)+2);
        end
    end
end
end
beta=inv(X'*X)*X'*Y;
% sum of squares
Y_est=X*beta;

```

```

% Final output display:
display('Minimum Least Squares Value')
display(SS_sort(1))
display('Sequence of Dependent Variables')
var_seq=cell(1,nq-2);
for i=1:nq-2
    var_seq(i)={f(i,n)};
end
display(var_seq)
display('Variables included in the model (1 = included, 0 = not included)')
%%% Need some labels.
display(P_sort(1,:))
display('Coefficients of the linear model. The first number is the
constant, while the subsequent numbers are the variable coefficients.')
display(beta)

% Test - Output a matrix A showing the actual values in the first column
and the predicted values in the second column.
A=zeros(m,3);
A(:,1)=data(:,V);
for j=1:m
    A(j,2)=beta(1);
    count=1;
    for i=1:nq-2
        if P_sort(1,i)==1
            count=count+1;
            indices=f(i,n);
            if size(indices,2)==1
                if indices~=i
                    display('f is not returning the correct index')
                end
                A(j,2)=A(j,2)+beta(count)*data(j,indices+2);
            else
                A(j,2)=A(j,2)+beta(count)*data(j,indices(1)+2)*data(j,indices(2)+2);
            end
        end
    end
end
end

% Percentage Errors
for i=1:m
    A(i,3)=abs(A(i,1)-A(i,2))/A(i,1)*100;
end
display('Actual values of DV in column 1, predicted values of DV in column
2, absolute percentage error in column 3.')
display(A)
display('Average Percentage Error')
display(sum(A(:,3))/m)

```


APPENDIX 3 AUSTRALIA'S LCCs PAX AND RPKs ARTIFICIAL ADAPTIVE NEURO-FUZZY INFERENCE SYSTEM (ANFIS) SURFACE DRAWINGS.

This appendix presents the ANFIS surface drawings of Australia's domestic LCC enplaned passengers (PAX) and RPKs models, interaction terms. The figures that follow show the obtained surfaces between the dependent variable and the selected input variables (the relationship is presented using the three dimension surfaces).in the ANFIS system.

APPENDIX 3.1 ANFIS Surface Drawings for Australia's LCC enplaned passengers (PAX) Model

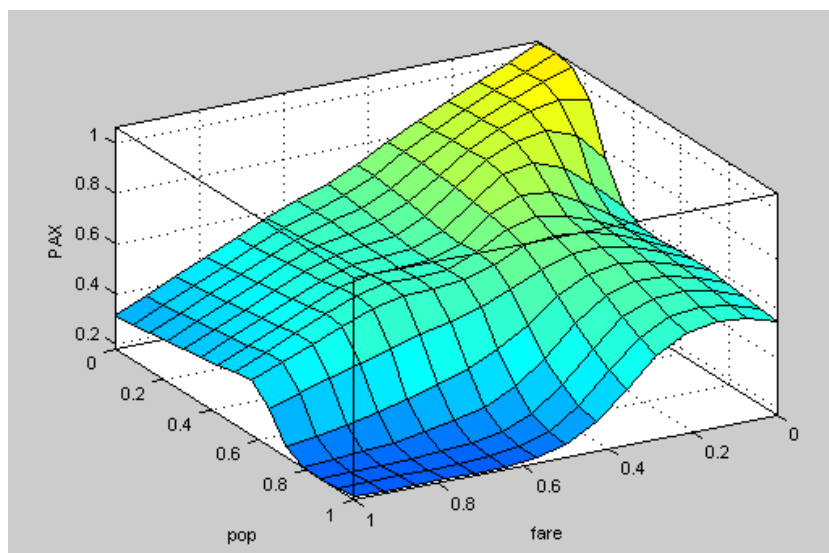


Figure A.1. Obtained surfaces of PAX versus Australia's population size and Australia's real best discount airfare in the ANFIS PAX model

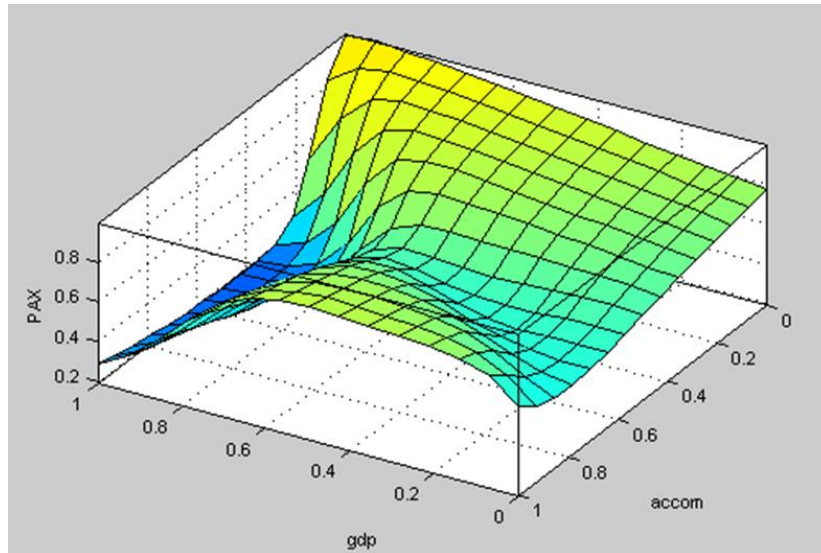


Figure A.2. Obtained surfaces of PAX versus Australia's real GDP and Australia's real best discount airfare in the ANFIS PAX model

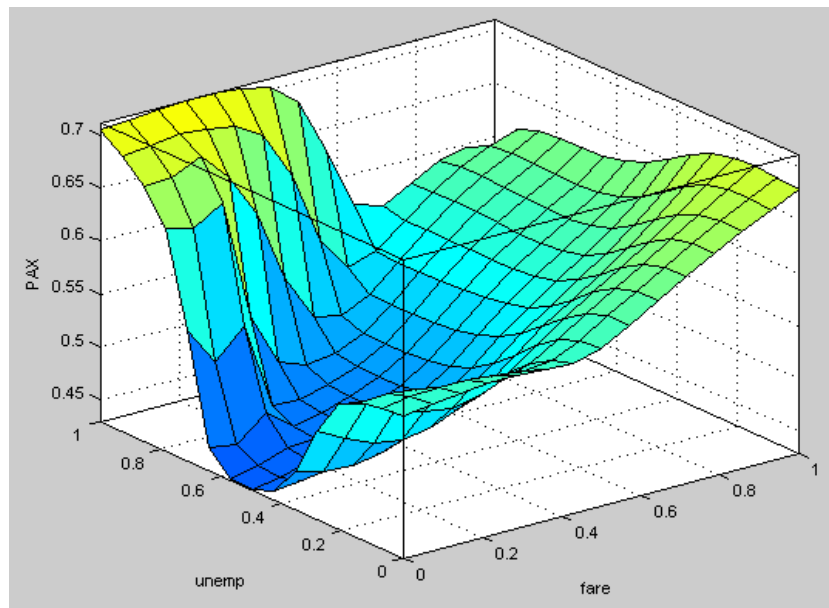


Figure A.3. Obtained surfaces of PAX versus Australia's unemployment size and Australia's real best discount airfare in the ANFIS PAX model

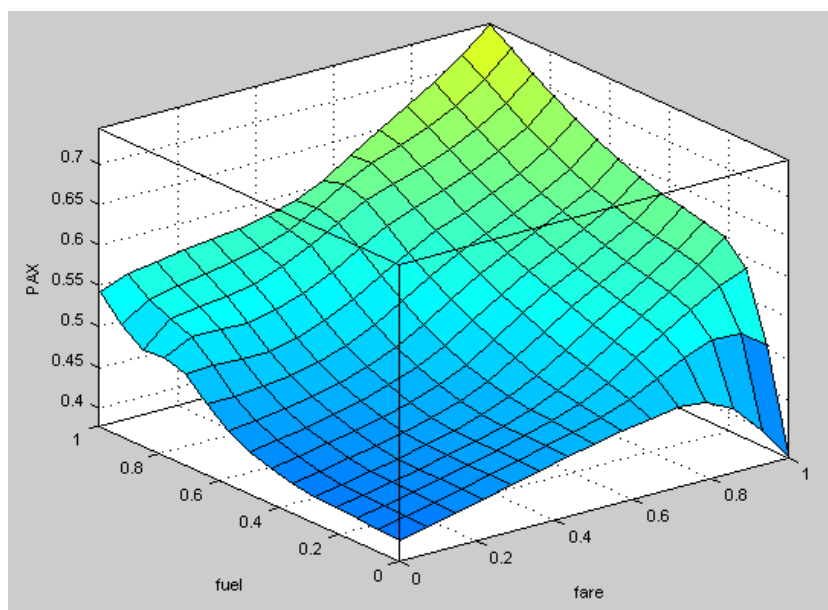


Figure A.4. Obtained surfaces of PAX versus world jet fuel prices and Australia's real best discount airfare in the ANFIS PAX model

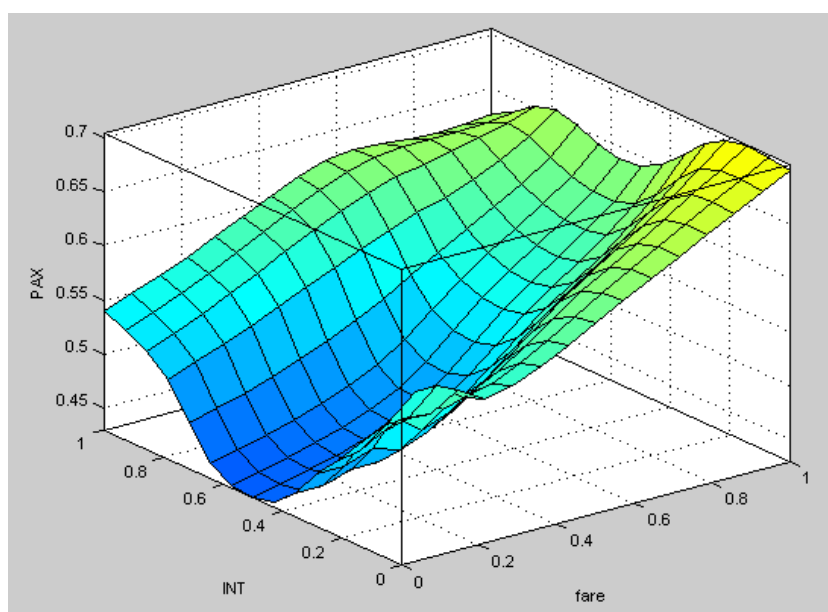


Figure A.5. Obtained surfaces of PAX versus Australia's real interest rates and Australia's real best discount airfare in the ANFIS PAX model

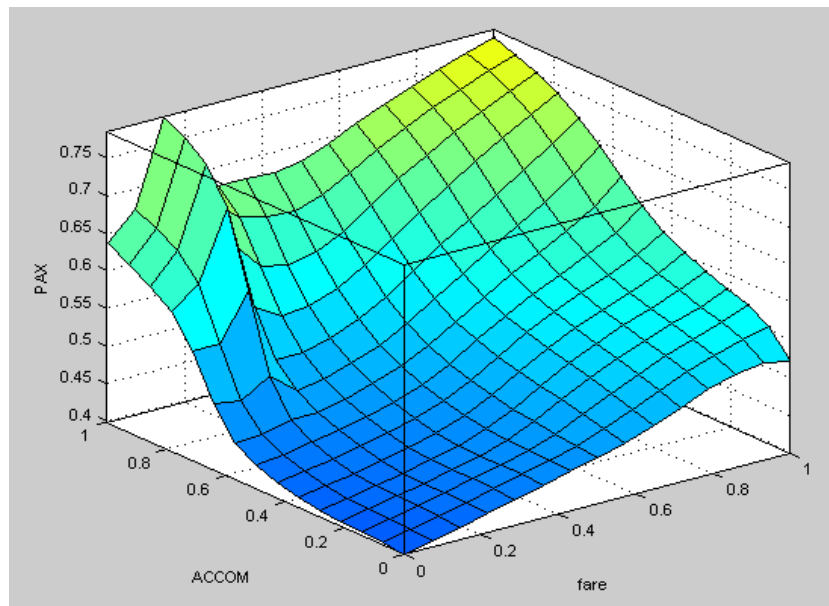


Figure A.6. Obtained surfaces of PAX versus Australia's tourist accommodation and Australia's real best discount airfare in the ANFIS PAX model

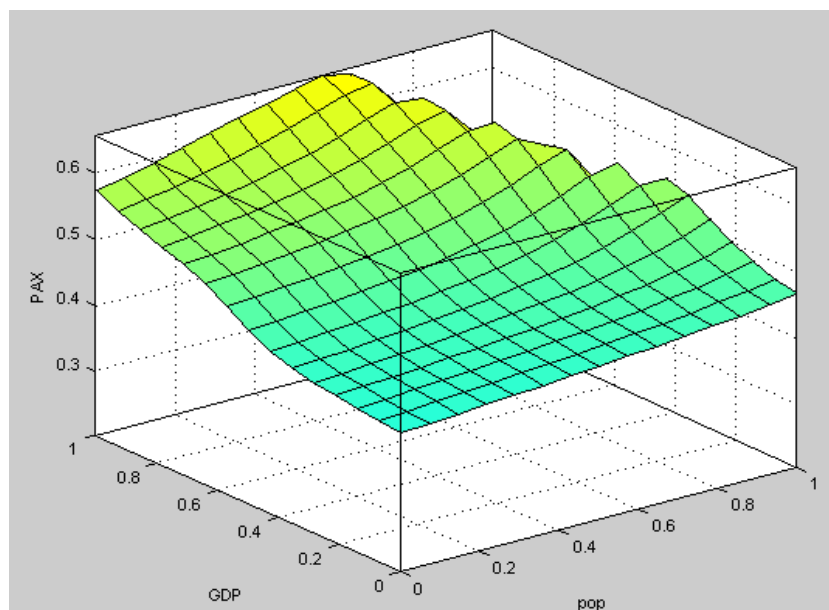


Figure A.7. Obtained surfaces of PAX versus Australia's real GDP and Australia's population size in the ANFIS PAX model

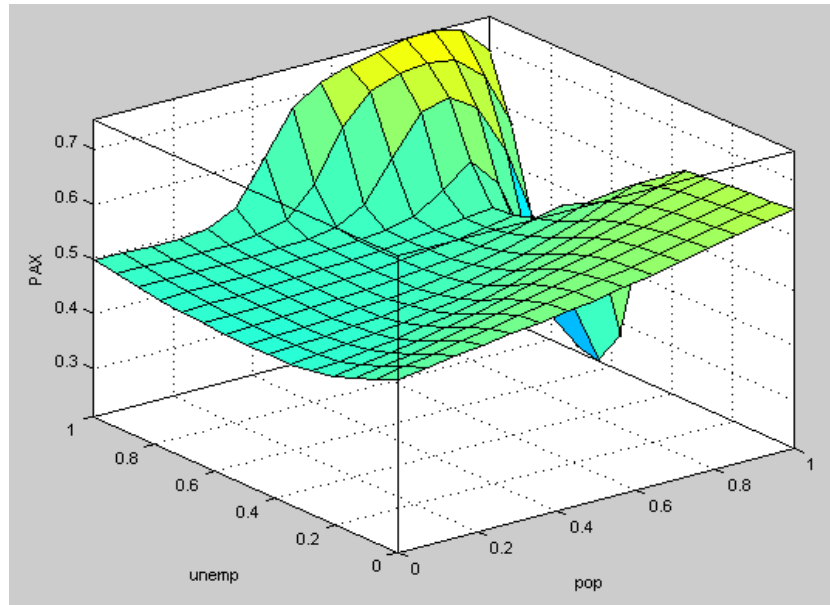


Figure A.8. Obtained surfaces of PAX versus Australia's unemployment size and Australia's population size in the ANFIS PAX model

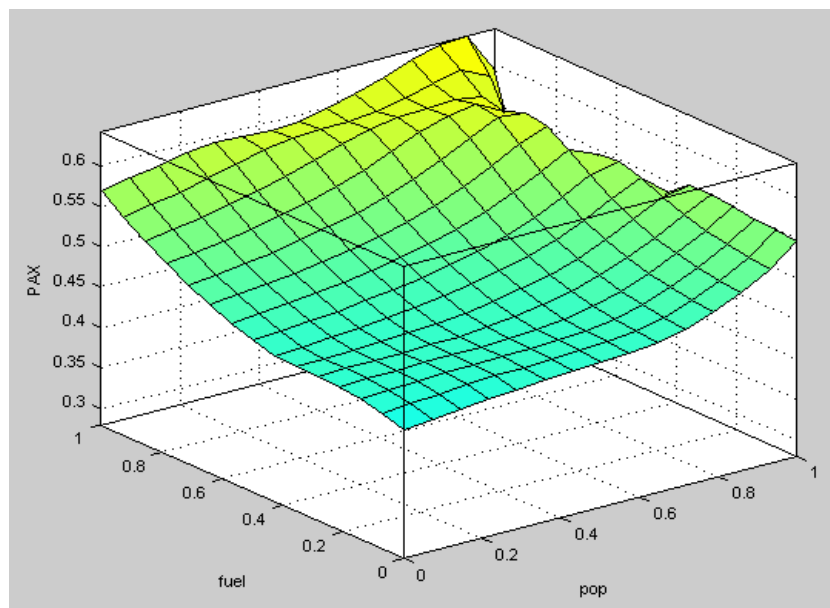


Figure A.9. Obtained surfaces of PAX versus world jet fuel price and Australia's population size in the ANFIS PAX model

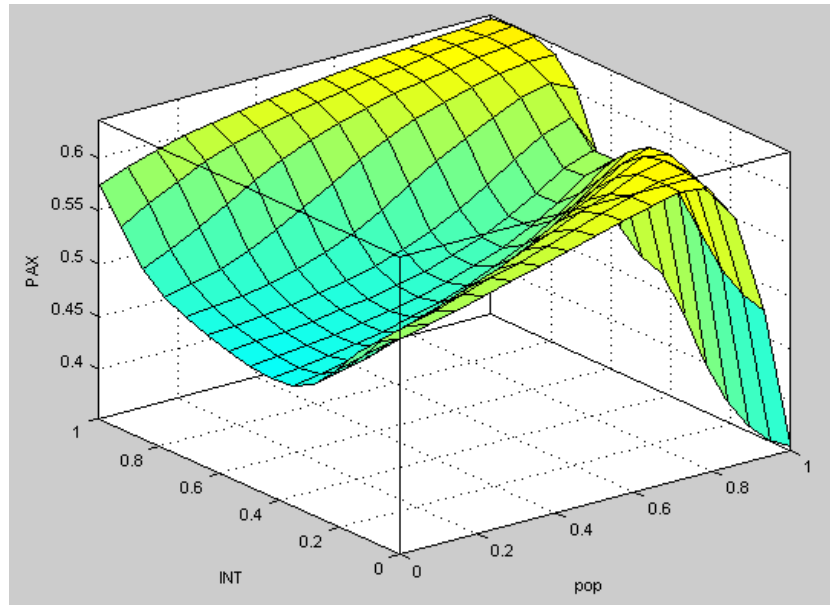


Figure A.10. Obtained surfaces of PAX versus Australia's real interest rate and Australia's population size in the ANFIS PAX model

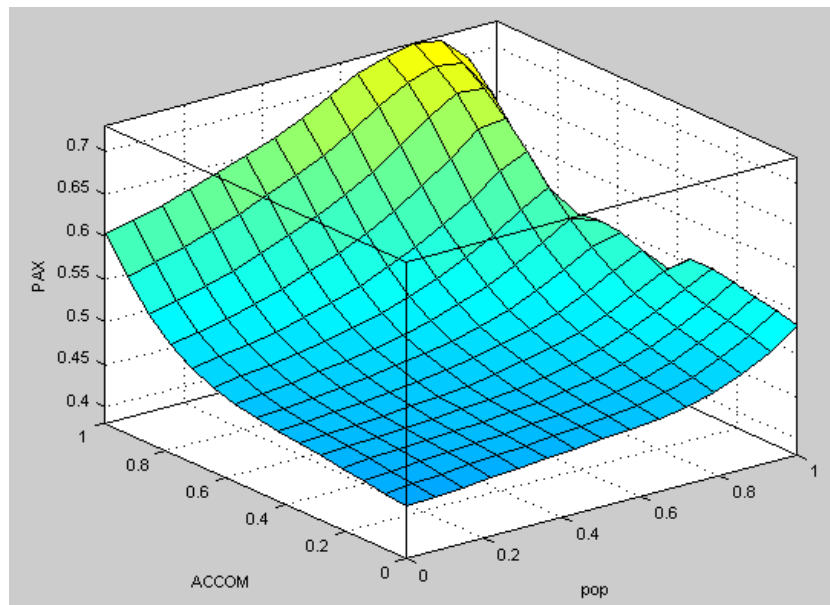


Figure A.11. Obtained surfaces of PAX versus Australia's tourist accommodation and Australia's population size in the ANFIS PAX model

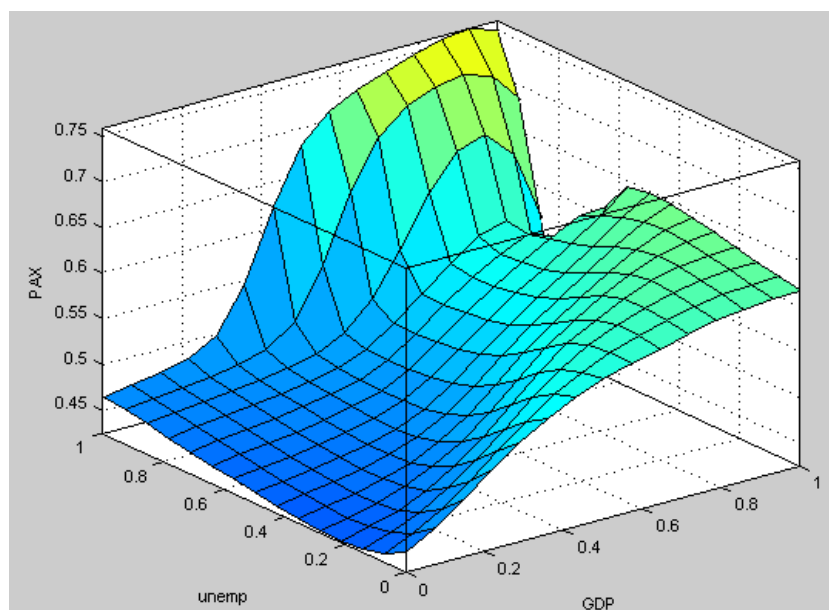


Figure A.12. Obtained surfaces of PAX versus Australia's unemployment size and Australia's real GDP in the ANFIS PAX model

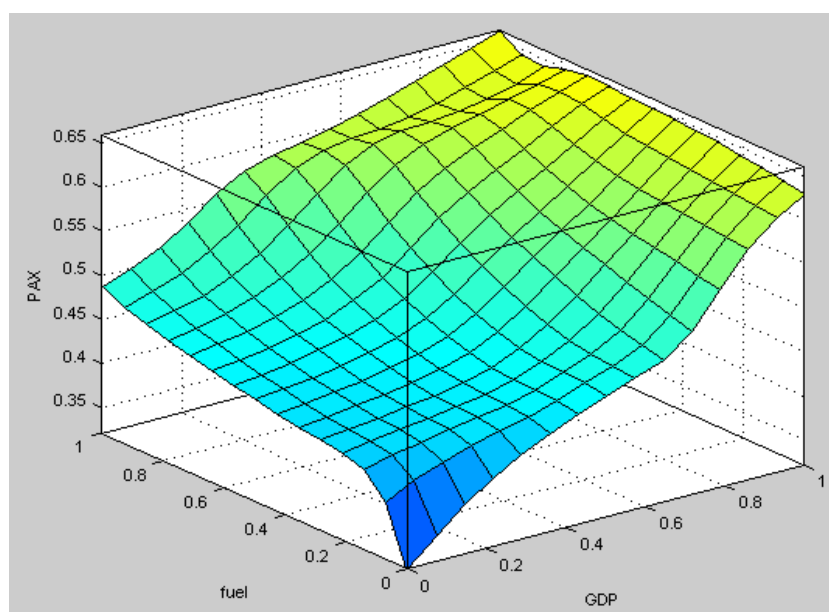


Figure A.13. Obtained surfaces of PAX versus world jet fuel price and Australia's real GDP in the ANFIS PAX model

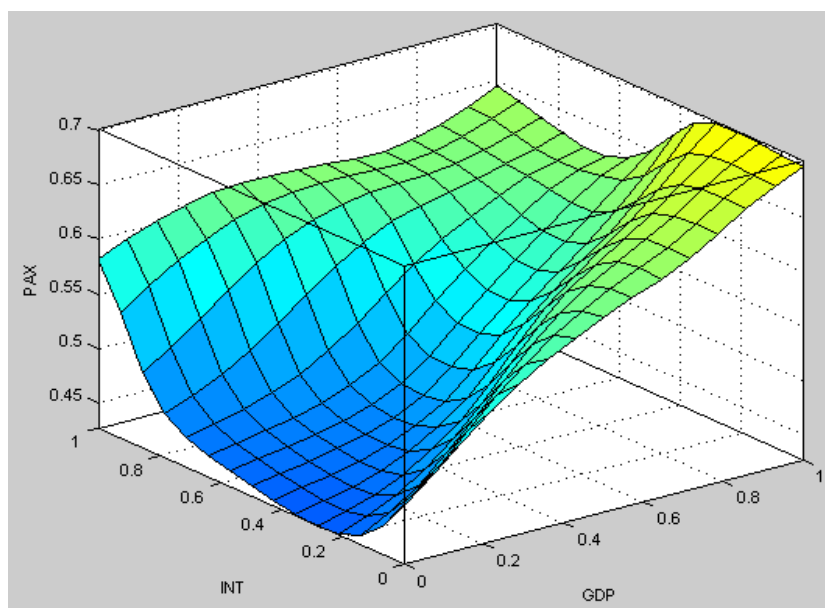


Figure A.14. Obtained surfaces of PAX versus Australia's real interest rate and Australia's real GDP in the ANFIS PAX model

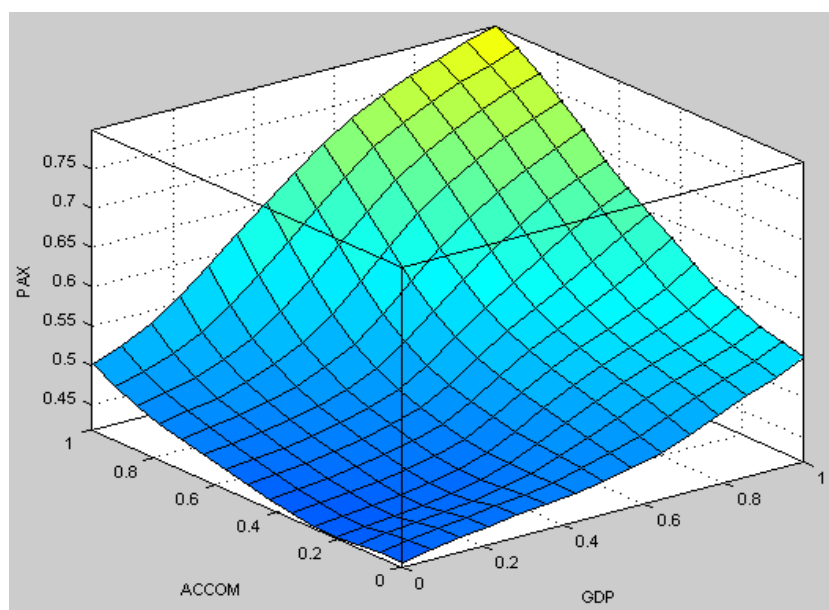


Figure A.15. Obtained surfaces of PAX versus Australia's tourist accommodation and Australia's real GDP in the ANFIS PAX model

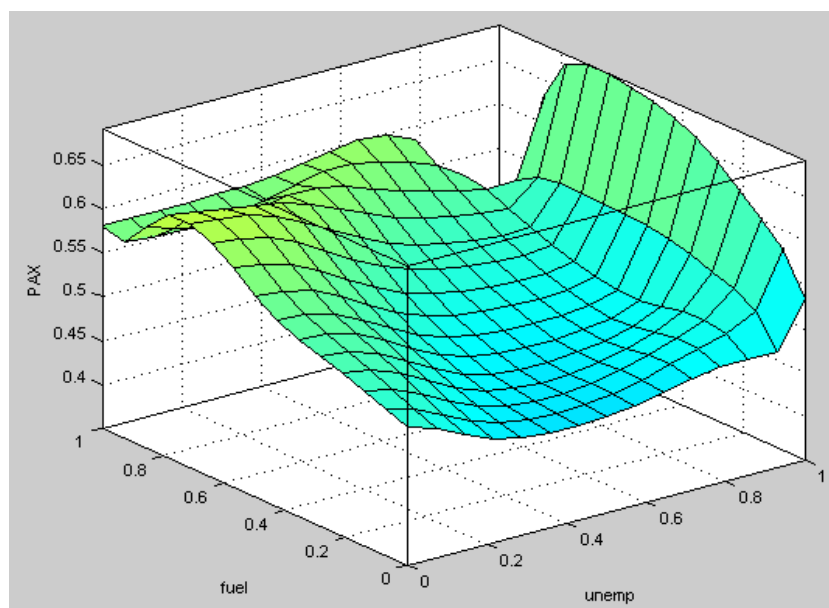


Figure A.16. Obtained surfaces of PAX versus world jet fuel price and Australia's unemployment size in the ANFIS PAX model

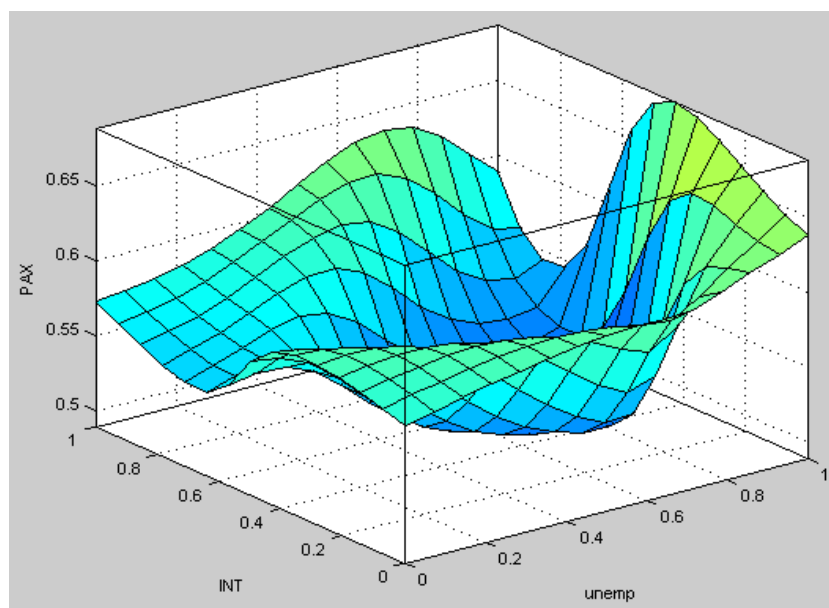


Figure A.17. Obtained surfaces of PAX versus interest rate and Australia's unemployment size in the ANFIS PAX model

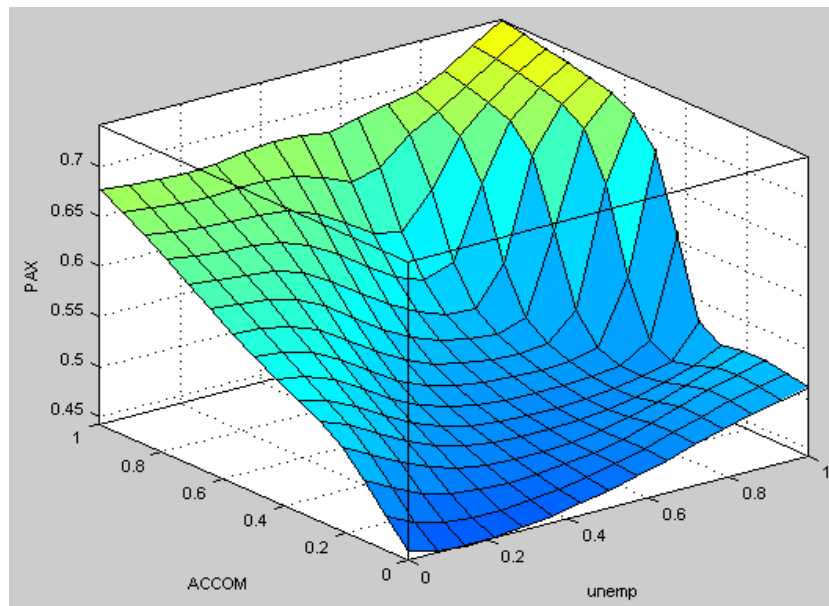


Figure A.18. Obtained surfaces of PAX versus Australia's tourist accommodation and Australia's unemployment size in the ANFIS PAX model

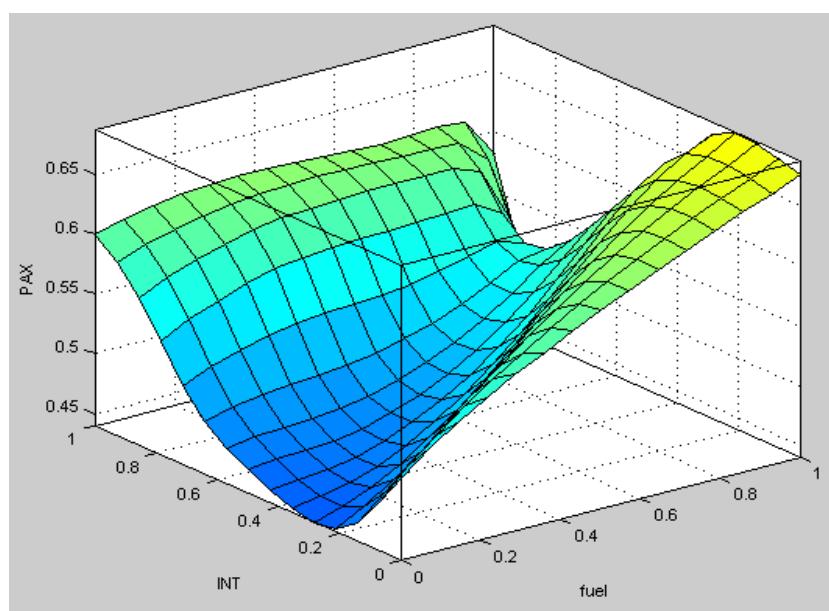


Figure A.19. Obtained surfaces of PAX versus Australia's real interest rate and world jet fuel price in the ANFIS PAX model

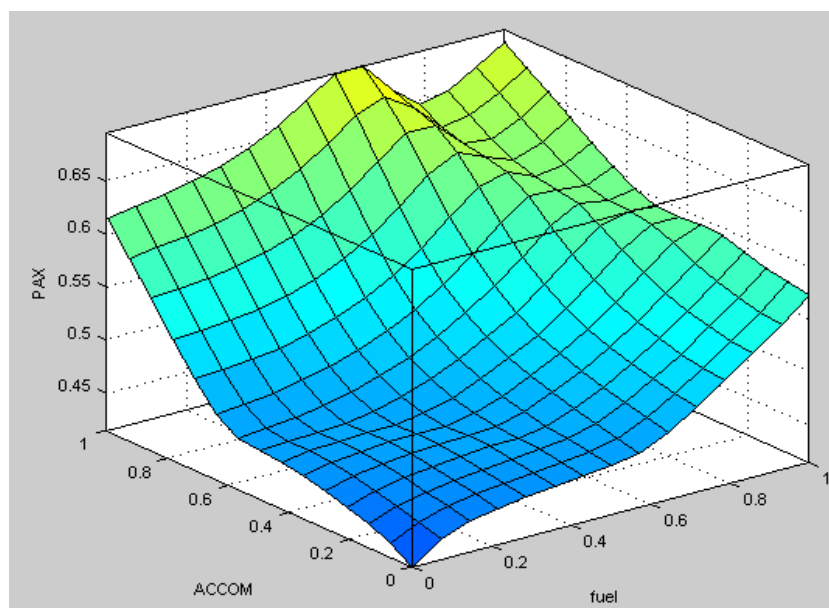


Figure A.20. Obtained surfaces of PAX versus Australia's tourist accommodation and world jet fuel price in the ANFIS PAX model

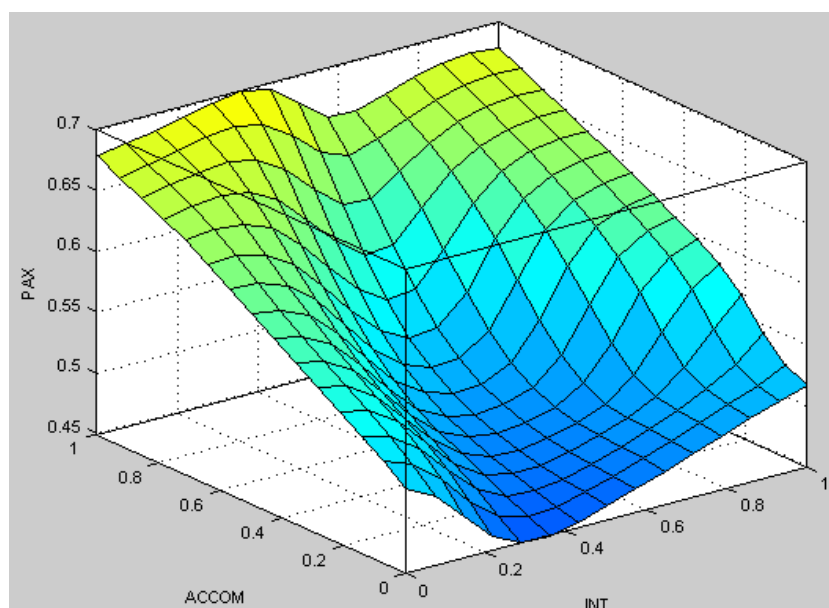


Figure A.21. Obtained surfaces of PAX versus Australia's tourist accommodation and Australia's real interest rate in the ANFIS PAX model

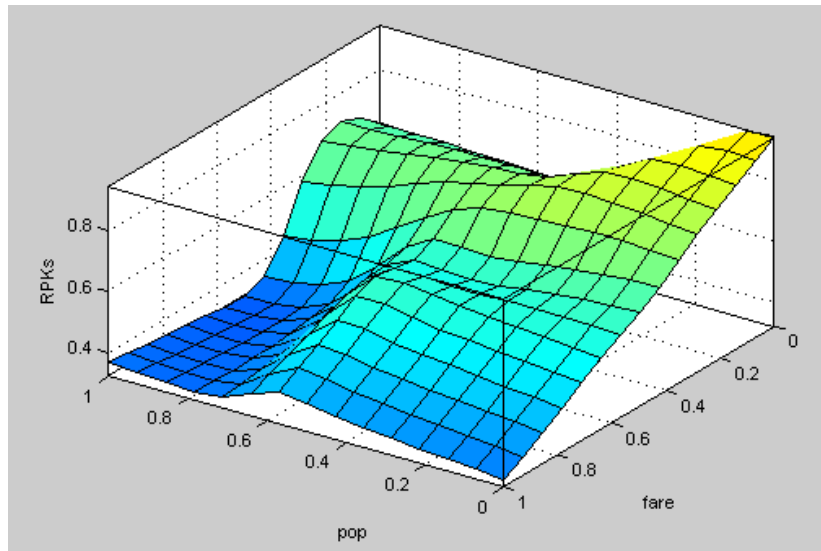
APPENDIX 3.2 ANFIS Surface Drawings for Australia's LCC RPK Model

Figure A.22. Obtained surfaces of RPKs versus Australia's population size and fare in the ANFIS RPKs model

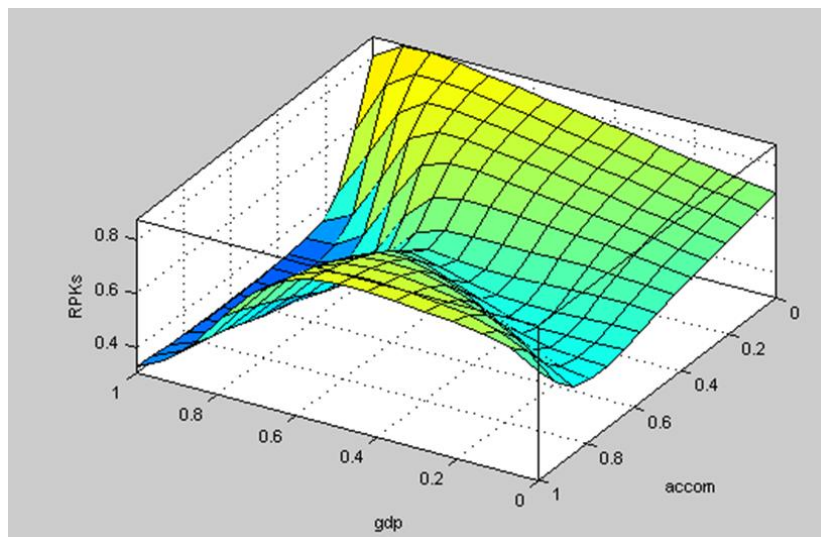


Figure A.23. Obtained surfaces of RPKs versus Australia's real GDP and fare in the ANFIS RPKs model

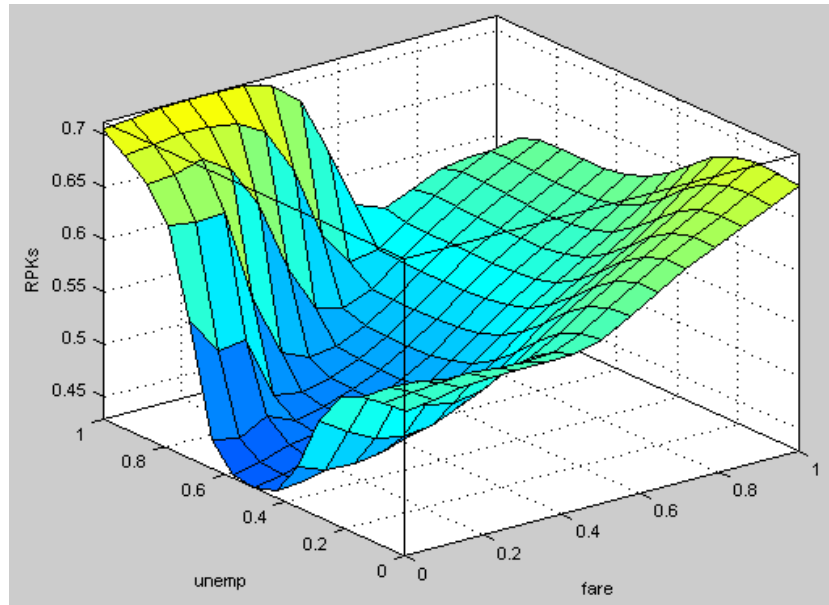


Figure A.24. Obtained surfaces of RPKs versus Australia's unemployment Size and fare in the ANFIS RPKs model

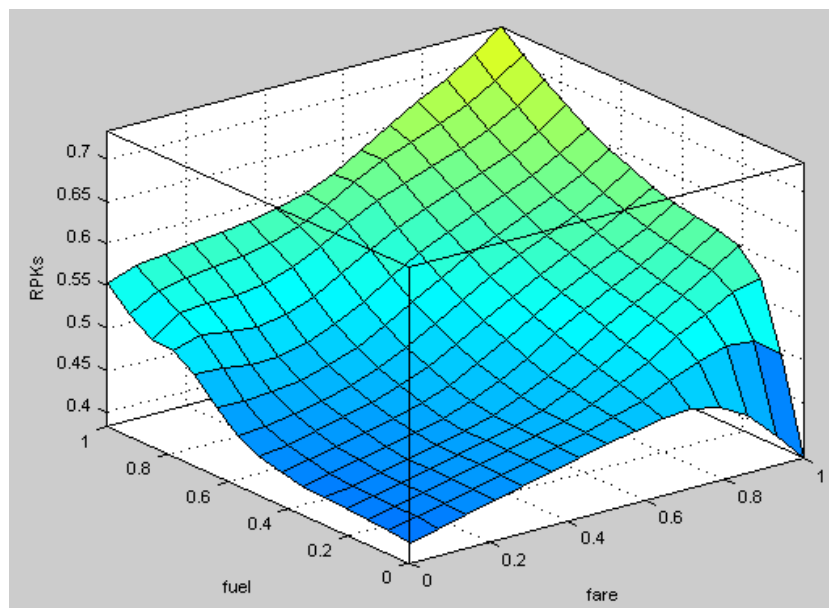


Figure A.25. Obtained surfaces of RPKs versus world jet fuel price and fare in the ANFIS RPKs model

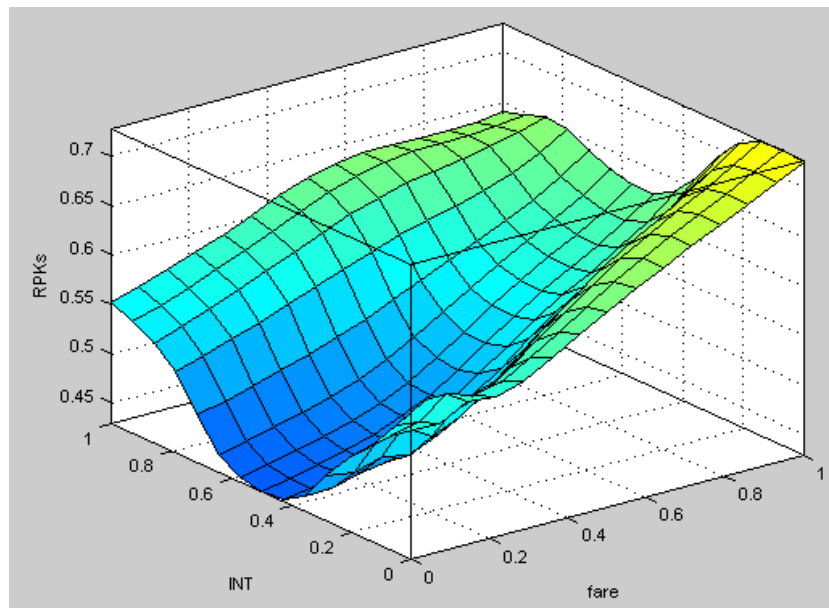


Figure A.26. Obtained surfaces of RPKs versus Australia's real interest rate and fare in the ANFIS RPKs model

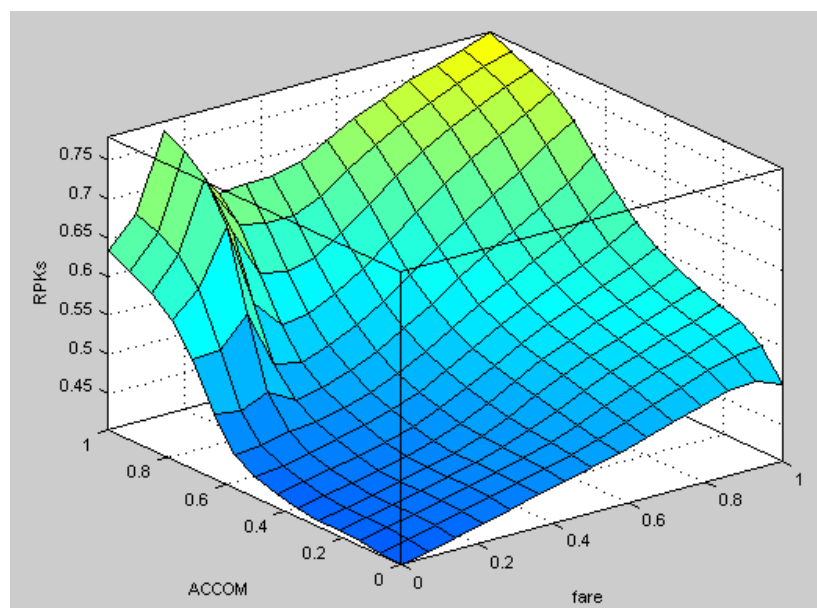


Figure A.27. Obtained surfaces of RPKs versus Australia's tourist accommodation and fare in the ANFIS RPKs model

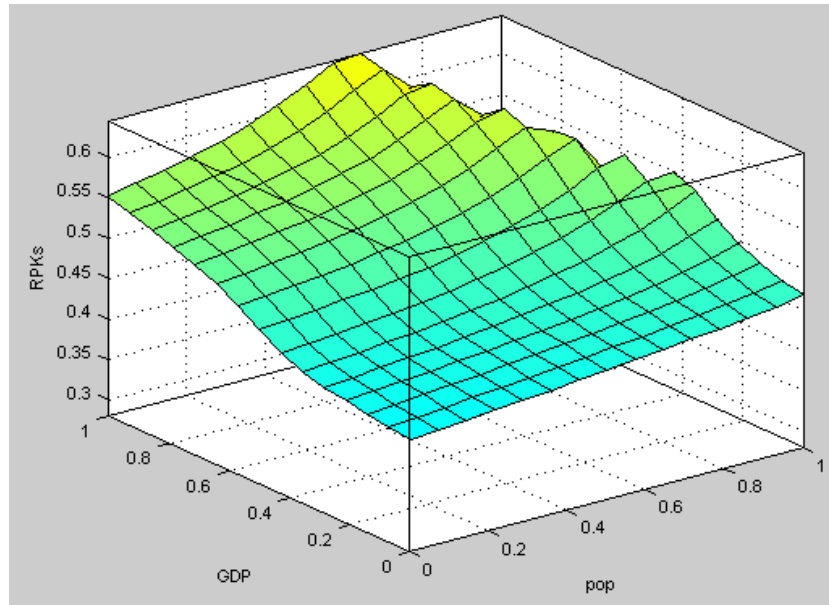


Figure A.28. Obtained surfaces of RPKs versus Australia's real GDP and Australia's population size in the ANFIS RPKs model

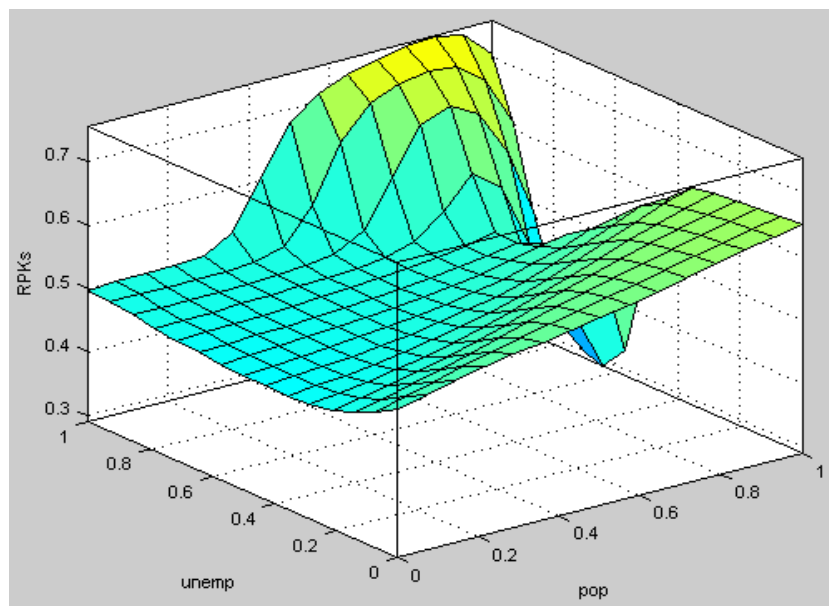


Figure A.29. Obtained surfaces of RPKs versus Australia's unemployment size and Australia's population size in the ANFIS RPKs model

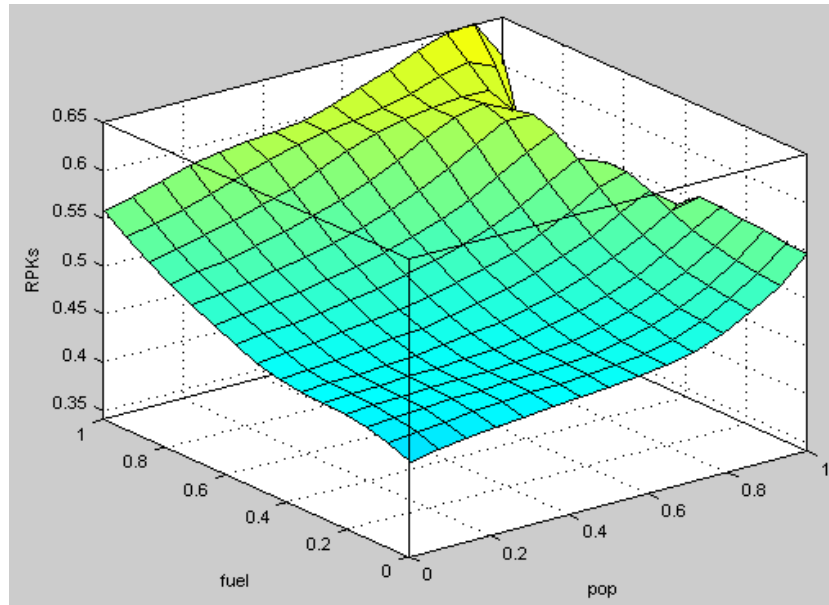


Figure A.30. Obtained surfaces of RPKs versus world jet fuel price and Australia's population size in the ANFIS RPKs model

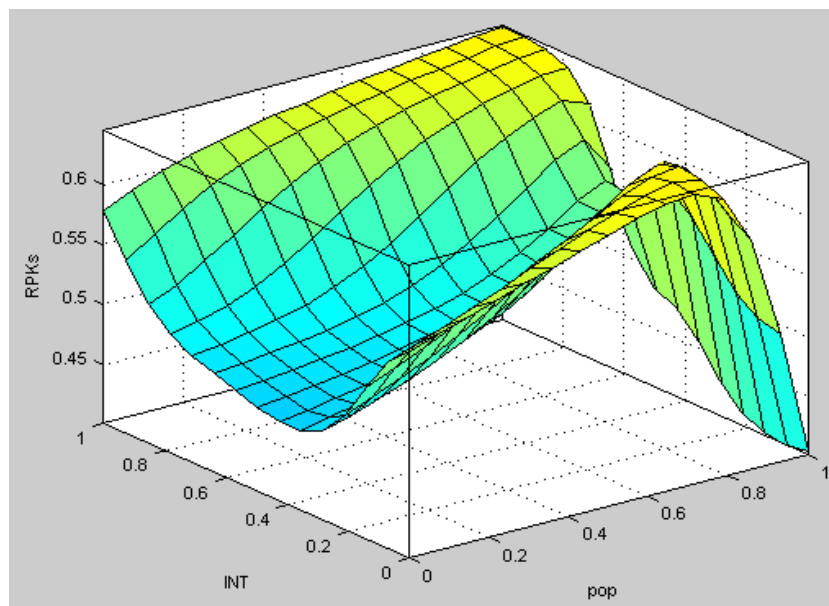


Figure A.31. Obtained surfaces of RPKs versus Australia's real interest rate and Australia's population size in the ANFIS RPKs model

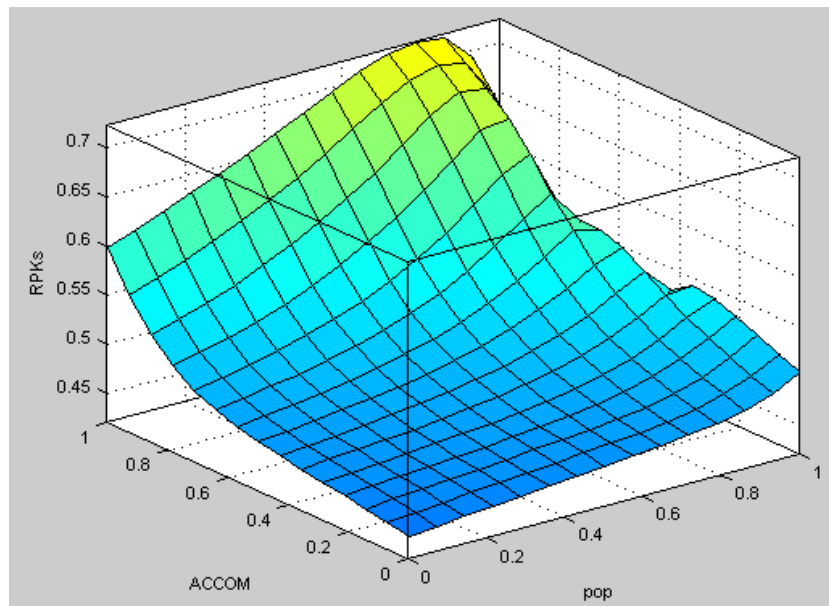


Figure A.32. Obtained surfaces of RPKs versus Australia's tourist accommodation and Australia's population size in the ANFIS RPKs model

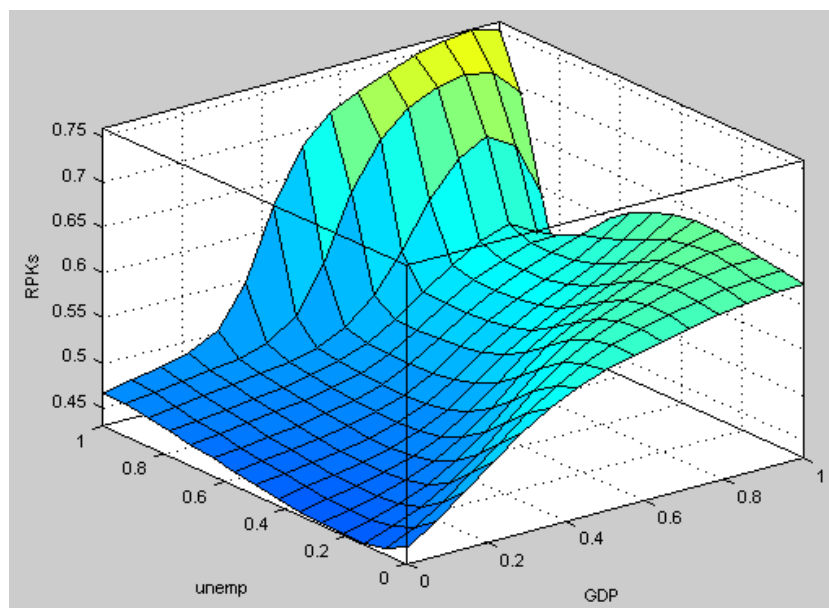


Figure A.33. Obtained surfaces of RPKs versus Australia's unemployment size and Australia's real GDP in the ANFIS RPKs model

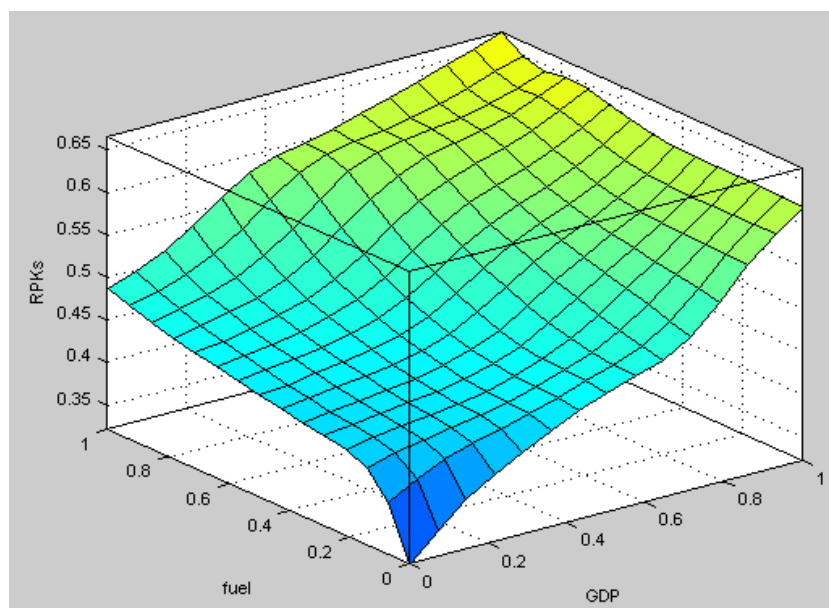


Figure A.34. Obtained surfaces of RPKs versus world jet fuel price and Australia's real GDP in the ANFIS RPKs model

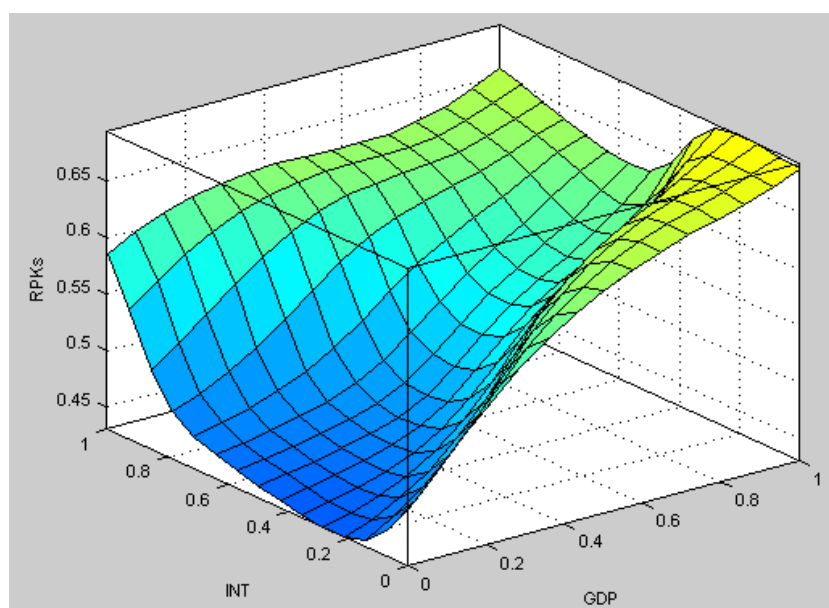


Figure A.35. Obtained surfaces of RPKs versus Australia's real interest rate and Australia's real GDP in the ANFIS RPKs model

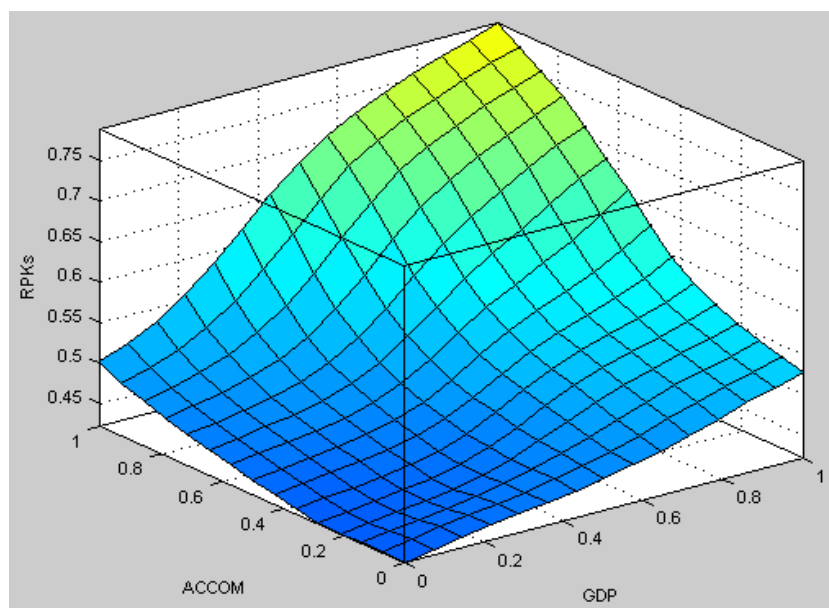


Figure A.36. Obtained surfaces of RPKs versus Australia's tourist accommodation and Australia's real GDP in the ANFIS RPKs model

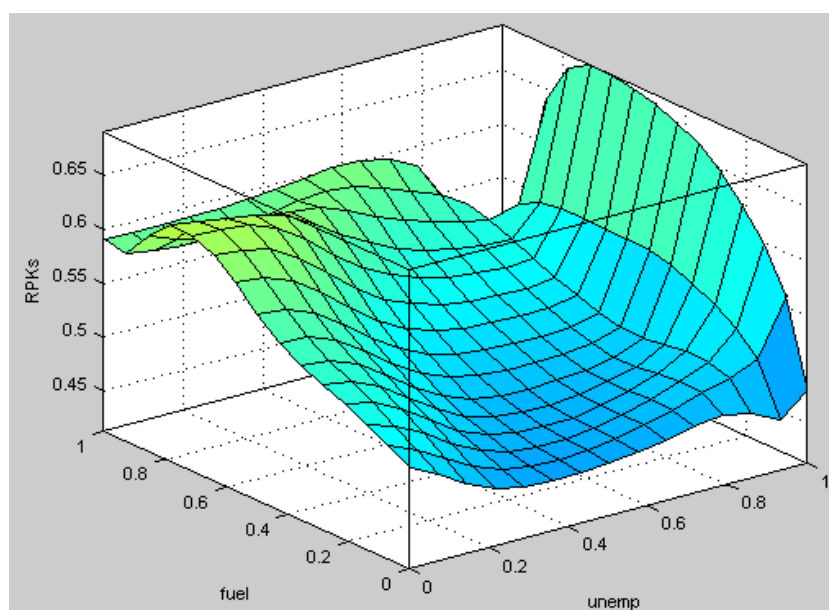


Figure A.37. Obtained surfaces of RPKs versus world jet fuel price and Australia's unemployment size in the ANFIS RPKs model

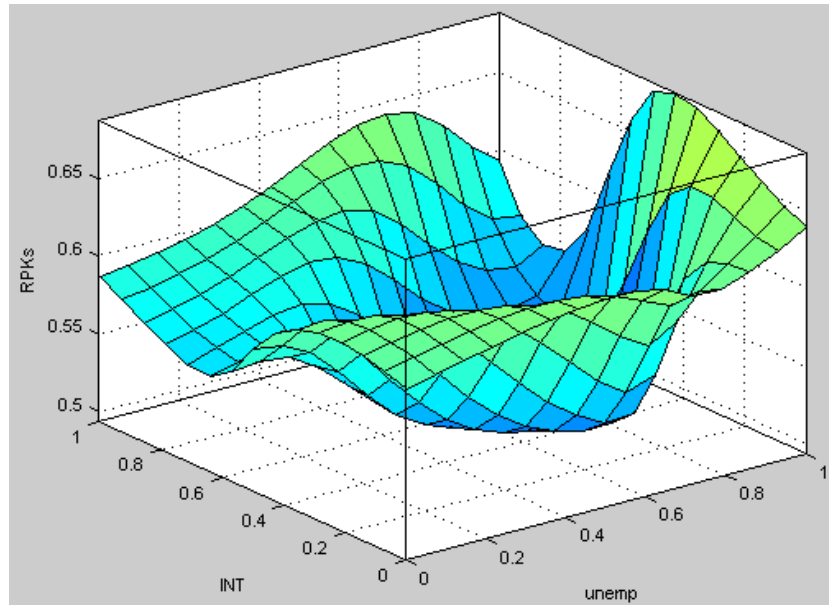


Figure A.38. Obtained surfaces of RPKs versus Australia's real interest rate and Australia's unemployment size in the ANFIS RPKs model

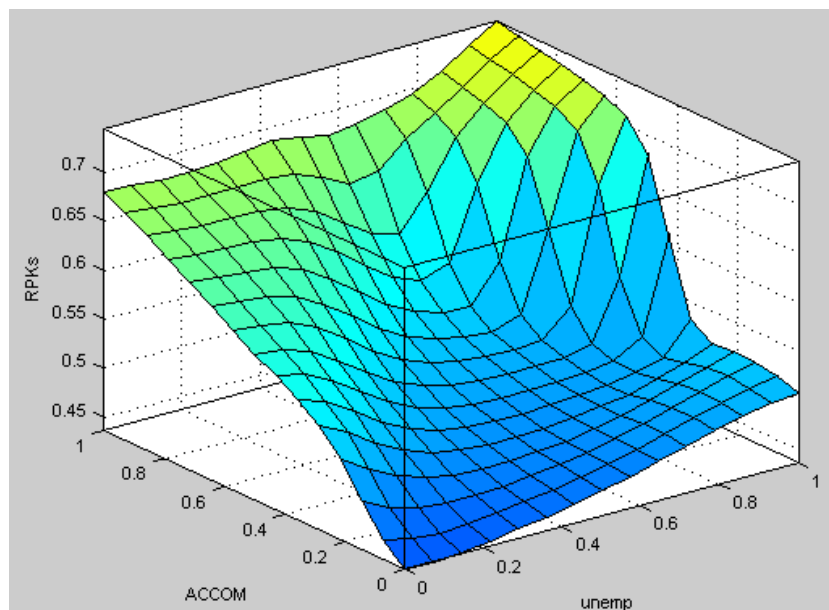


Figure A.39. Obtained surfaces of RPKs versus Australia's tourist accommodation and Australia's unemployment size in the ANFIS RPKs model

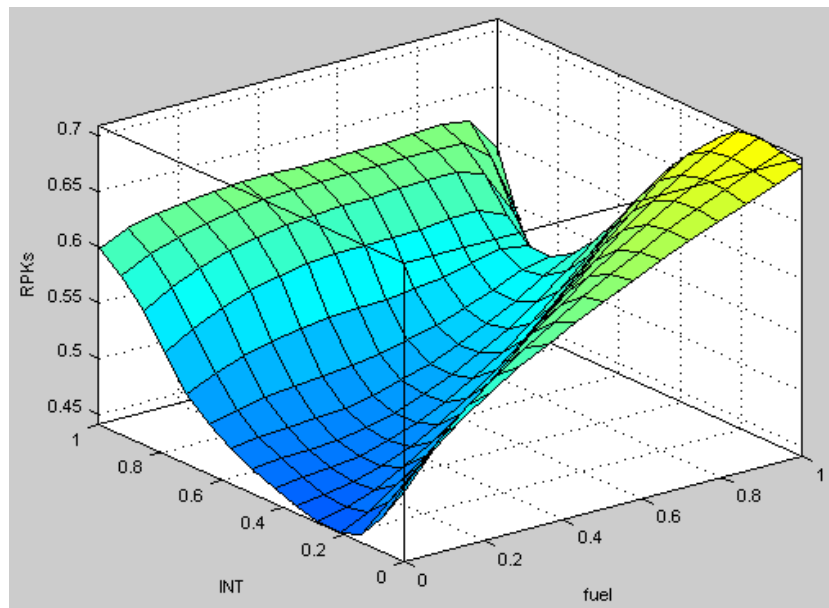


Figure A.40. Obtained surfaces of RPKs versus Australia's real interest rate and world jet fuel price in the ANFIS RPKs model

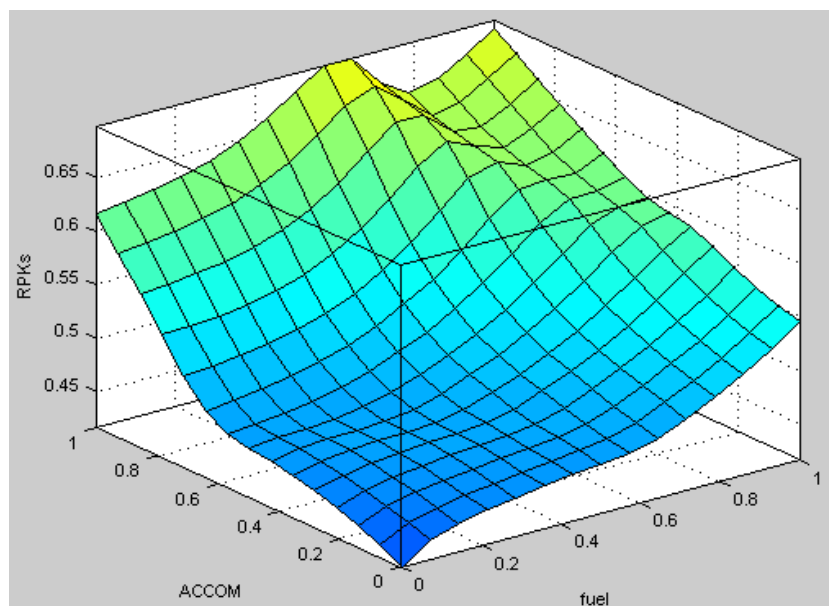


Figure A.41. Obtained surfaces of RPKs versus Australia's tourist accommodation and world jet fuel price in the ANFIS RPKs model

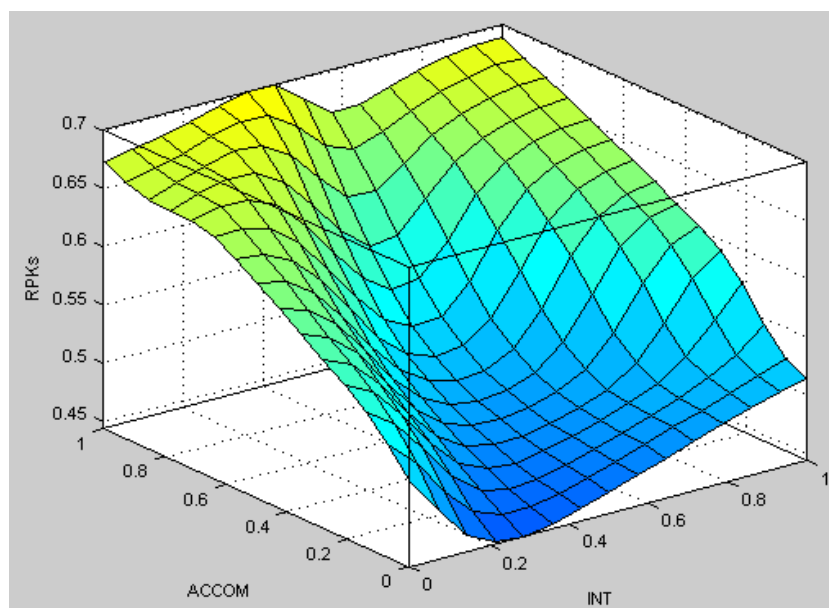


Figure A.42. Obtained surfaces of RPKs versus Australia's tourist accommodation and Australia's real interest rate in the ANFIS RPKs model

APPENDIX 4 The *HAC* (heteroscedasticity and autocorrelation consistent) method of correcting the OLS standard errors

This study used the *HAC* (heteroscedasticity and autocorrelation consistent) method to correct the bias of standard errors and t-statistics, if present (Gujarati 2003). This method also used by Berg and Coke (2004). The *HAC* method can correct standard errors and t-statistics. After using the *HAC* method, adjusted standard errors and t-statistics would be presented while the coefficient estimator remains the same (Gujarati 2003). This method enhanced the robustness of standard errors and t-statistics which provide the consistent parameter estimates of the model.

The results in Table A.1 and A.2 show that the standard errors and *t-test* of the original PAX and RPKs models being adjusted in order to make them more accurate and reliable.

Table A.1 The results of PAX model using the HAC method

Variable	Coefficient	Std. Error (original)	Std. Error (adjusted)	t-Statistic (original)	t-Statistic (adjusted)
X_1	-16.49	6.01	7.26	-2.74	-2.27
X_2	1.94	0.24	0.19	8.09	10.17
X_3	-212.58	74.85	76.85	-2.84	-2.77
X_4	-4758.36	204.16	197.79	3.04	3.14
X_5	-22977.26	211.75	160.01	-22.47	-29.74
C	-16.49	3751.21	2986.38	-6.13	-7.69

Table A.2 The results of RPKs model using the HAC method

Variable	Coefficient	Std. Error (original)	Std. Error (adjusted)	t-Statistic (original)	t-Statistic (adjusted)
X_1	-18.79	6.83	8.20	-2.75	-2.29
X_2	2.39	0.27	0.18	8.79	13.09
X_3	-198.26	85.01	81.28	-2.33	-2.44
X_4	-4981.65	231.85	202.31	2.73	3.12
X_5	-29708.15	240.47	175.70	-20.72	-28.35
C	-18.79	4259.94	2832.19	-6.97	-10.49

Table A.1 and A.2 compares the estimated coefficient, standard errors and t-statistics between the original and the corrected models. As can be seen the estimated coefficient remained the same but the standard errors of the *HAC* method have been corrected. This method enhanced the robustness of standard errors which provide the consistent parameter estimates of the model.

APPENDIX 5 A REVIEW OF THE MODELLING APPROACHES

The theoretical approaches for forecasting airline passenger air travel demand in the late 1940s and early 1950s were based on the use of gravity and multiple linear regression models (Wang & Song 2010). During this period, passenger flows were typically forecast between pairs of airports or between city pairs (Mayhill 1953). Seminal econometric air travel demand forecasting studies during the period from 1950 to 2014 include, among others (Wang & Song 2010), Lansing et al. (1961); Ghobrial (1992); Poore (1993); Alperovich & Machnes (1994); Ba-Fail et al. (2000), and Abed et al. (2001). Most of these studies, however, focused on the United States and European air travel markets. Also, these studies have predominantly used aggregated data.

There have only been a few reported comprehensive surveys of the air travel forecasting studies. For example, Sarames (1972) briefly reviewed world air travel demand between 1950 and 1980. In a further study, Karlaftis (1994) conducted an in-depth examination of air travel demand forecasting methodologies. Melville (1998) reviewed international airline travel demand. In this study, Melville concluded that there were less than 20 studies that had examined the importance of international air travel demand forecasting across various countries. Wang and Song (2010) have provided the most recent and largest scale of literature survey on air travel demand studies. The authors placed particular emphasis of their review on research development, publication sources, geographic focus, drivers of air travel demand, demand modelling and forecasting techniques, demand elasticity analysis, and leisure/tourism air travel demand (Wang & Song 2010).

A5.1 Evolution of air travel demand

Following the end of World War II, the global air transport industry has been a high growth industry. Indeed, a unique aspect of global aviation is that the industry has recorded strong growth in passenger demand. According to Air Transport Action Group (2000), throughout “the 1980s, and also for most of the 1990s, world airline passenger traffic grew on average by 6 per cent per annum”. The extremely tragic events of 9/11 resulted in a downturn in international airline traffic (Wang & Song 2010). The airline industry also experienced a serious downturn in passenger traffic as a result of the recent global financial crisis (GFC) from 2007 to 2009 (Centre for Aviation 2011). However, over the past few years the growth

in air travel demand has slowly returned. Interestingly, several impact analyses of air travel demand for the post 2001 period have been conducted (Wang & Song 2010).

Wang and Song (2010) have stated that there has been a growing interest in studying air travel demand forecasting in recent times. The two authors presented a comprehensive review of previous air travel demanding forecasting studies that had been conducted over the period 1950-2008. This thesis has extended the work of Wang and Song (2010) on air travel demand modelling, by examining air travel demand forecasting studies that have been conducted over the period 2008 to 2014.

Figure A5.1 shows that there were 7 studies devoted to air travel demand forecasting in the period 1950-1980. During the period from 1981-2000, a total of 23 studies on air travel demand forecasting were reported in the literature. In the post 2001 (9/11) period, there has been a considerable increase in air travel demand forecasting studies, with a total of 33 studies undertaken and reported over this period. As can be seen in Figure A5.1, air travel demand forecasting has been regarded as a critical research area throughout the period 1950-2014.

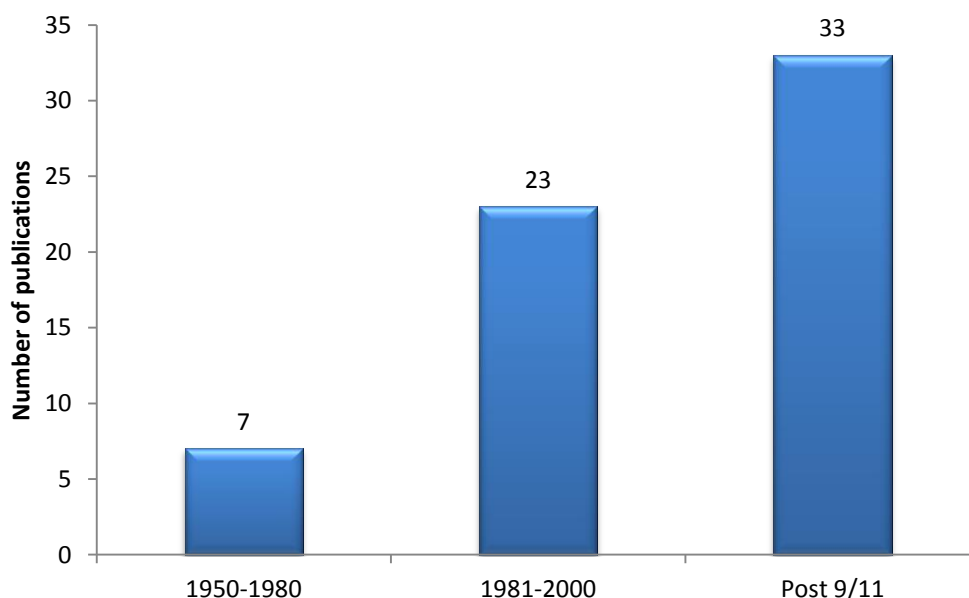


Figure A5.1. Number of publications of air travel demand modelling and forecasting studies: 1950-2014.

A5.2 Regional focus of air travel demand modelling and forecasting studies

The air travel demand studies examined as part of this thesis found the reported studies had a specific geographical focuses. The studies have been based on international, domestic, regional, and intercity levels. Some studies have focused on specific airports (Wang & Song 2010). The majority of air travel demand research has principally focused on the United States, Asia, Europe, and Australia (Figure A5.2). Wang and Song (2010, p. 39) noted that the “popularity of air travel demand research on the United States could be explained by its long history of air transport industry development”.

As can be observed from Figure A5.2, there have been 5 reported Australian passenger air travel demand-related forecasting studies. Three of these studies have examined Australia’s domestic air travel demand, whilst the other two have examined Australia’s international air travel demand. Importantly, there have been no reported studies that have empirically examined Australia’s domestic LCC passenger demand.

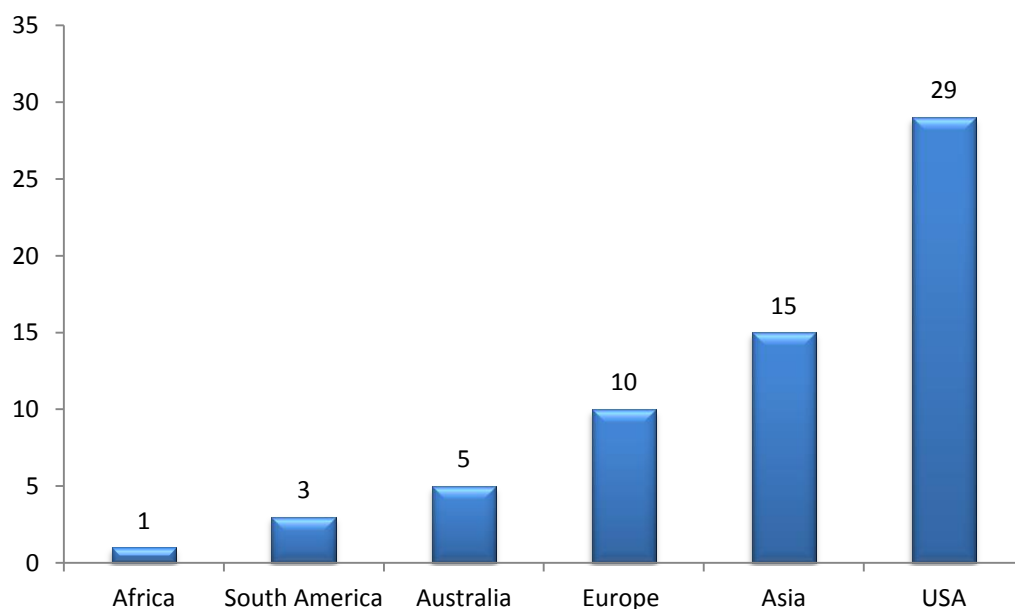


Figure A5.2. Summary of regional focus of air travel demand modelling and forecasting studies: 1950-2014.

A5.3 Evolution of air travel demand modelling and forecasting techniques: 1950-2014

As previously noted, the period for study of air transportation demand modelling was divided into three distinct phases; 1950-1980, 1981-2000 and post 2001 (9/11) (Wang & Song 2010). According to thesis literature survey, it is clear that most air transportation demand modelling, and forecasting, methods have mainly used an econometric approach. Amongst these 63 studies, 55 studies used econometric approach in their research, while 8 other studies introduced alternative artificial intelligence-based approaches; such as the artificial neural network model (ANN); fuzzy model; the integrated mixture of local experts model (IMLEM); and the adaptive neuro-fuzzy inference system (ANFIS) approaches, in their studies.

During 1950-1980, air travel demand studies predominantly used direct demand models in order to analyse air travel demand (see, for example, Brown & Watkins 1968; Bower 1976). During the 1970s, several studies used logit model to develop air travel demand (Alamdari & Black 1992; Brooke et al. 1994). As compared with the published air travel demand forecasting studies published prior to 2001, modern air travel demand modelling methodologies have become more diverse and sophisticated in nature. Indeed, advanced models have been introduced to deal with the complexity in air travel demand forecasting (Wang & Song 2010).

According to Song and Li (2008, p. 204), the econometric approaches that have been used in air travel demand modelling was dominated by two sub-categories of methods:

- causal demand models such as multiple linear regression model (MLR).
- non-causal time-series demand models, such as, Autoregressive integrated moving average models (ARIMA) (Song & Li 2008).

One of the major advantages of the causal demand model over the time-series demand models lies in their ability to analyse causal relationships, between the air travel demand dependent variables, and their influencing factors or explanatory variables (Song & Li 2008; Doganis 2009). However, Frechtling (1996, 2001) argued that the disadvantages of using regression models include the large costs involved, the required substantial skill, and the need to forecast the independent variable in order to obtain forecasts of the dependent

variable. Econometric analysis achieves many useful roles beyond just the generation of forecasts. For example, econometric models provide a very useful framework that can underscore a progressive research strategy (Clements & Hendry 1998; Song & Li 2008). Notwithstanding, a time-series model cannot be of assistance when interdependent relationships among air travel demand, and other-related factors, are major concerns of businesses and governments (Song & Li 2008, p. 211).

Gravity models³³ were also widely used as a forecasting method in the early air travel demand forecasting studies (Fridström & Thune-Larsen 1989; Hutchinson 1993). These models were primarily based on forecasting air travel demand in origin-and-destination (O/D) city pairs (Wang & Song 2010). Gravity models have been extensively in previous research as a means to analyze bilateral activities. These activities have been diverse in scope, and have included passenger and air cargo flows, trade patterns, and investments. Gravity models are typically estimated using regression techniques. Gravity models also offer the ability to investigate the determinants that can significantly affect bilateral flows, such as, passengers (Chang 2014). Interestingly, despite their early development, there have been several air travel demand forecasting reported studies after 2007 that have been based on a gravity model approach (see, for example, Bhadra & Kee 2008; Grosche et al. 2007; Hazledine 2009; Wadud 2011).

To alleviate spurious regression, which can quite often appear in traditional regression analysis based on ordinary least squares (OLS), a substantial effort has been undertaken in order to further advance the use of the causal demand approach in air travel demand modelling and forecasting (Song & Li 2008).

Several new multivariate forecasting techniques, such as the Error Correction Model (ECM) (Koo et al. 2013), and the vector autoregressive (VAR) model (Blunk et al. 2006), have also been proposed in the literature. Song and Li (2010, p. 211) noted that “apart from the VAR model, these modern econometric models are known as the single-equation modelling approach, and the explanatory variables included in the models should be exogenous”. Conversely, the VAR model treats all variables as endogenous. With this modelling approach each variable is specified as a linear relationship with the other variables included in the model (Song & Li 2008).

³³ The gravity model was first introduced in 1858 by Henry Carey. This model has become known as the ‘gravity concept of human interaction’ (Doganis 2009).

In 1991, Friedman proposed “a non-parametric *multivariate adaptive regression spline approach* (MARS)” forecasting approach. This approach is a non- parametric and nonlinear regression methodology. According to Chang (2014), the MARS forecasting method offers many advantages:

- no restrictions on the underlying relationships between the response variable and explanatory variables,
- no requirement to specify the function form as the parametric linear regression technique,
- the greater flexibility of MARS to explore the non-linear relationships between a response variable and explanatory variables through the fitting of the model data into a series of spline functions (Chang 2014, p. 124).

Chang (2014, p. 124) stated that “basic principle of MARS is to allow different functions over different intervals...the nonlinear relationship between a response variable and an explanatory variable is approximated by the use of separate regression slopes in distinct intervals of the explanatory variable region”. Chang (2014, p. 124) continued “since this approach allows for all functional forms and interactions, MARS is able to effectively track the complex data structures hidden in high-dimensional data”.

Chang 2014 employed the (MARS) model to explore the determinants and the extent of their influence on the demand for cross-country air transport in the Asia-Pacific Economic Cooperation (APEC) region (Chang 2014).

According to Song and Li (2008, p. 210), a “*time-series model* explains a variable with regard to its own past and a random disturbance term”. When using a time-series approach, the analyst must pay particular attention to investigating historic trends and patterns (such as seasonality) in the time series under study, and to then forecast the future based on these observed trends and patterns identified in the model (Song & Li 2008).

Time-series models have been used extensively for air travel demand forecasting (see, for example, Anderson & Kraus 1981; Castillo-Manzano et al. 2012; Lai & Lu 2005; Oberhausen & Koppleman 1982; Pitfield 2007, 2008; Sen 1985; Uddin et al. 1985). The most common time-series approach has been the integrated *autoregressive moving-average models* (ARIMA), which was proposed by Box and Jenkins (1970). However, different versions of the ARIMA models have been applied in air travel demand modelling. The different versions of

the ARIMA models are dependent on the frequency of the time series. These include simple ARIMA, or seasonal ARIMA (that is, SARIMA) models (Song & Li 2008).

The forecasting performance of the ARIMA/SARIMA models has been improved in recent times by utilizing alternative time-series approaches (Song & Li 2008). One approach has been to extend the univariate time-series models to a multivariate dimension, as well as examine if the additional information involved in the time series may improve the model's forecasting accuracy (Song & Li 2008; Wang & Song 2010). For instance, Pitfield (2008) introduced an ARIMA model which included an intervention function in order to capture the impact of Southwest Airlines start-up services on passenger traffic volumes and airline market share in a variety of US domestic city pairs.

In an earlier approach, Scarpel and Milioni (2007) introduced "an *Integrated Mixture of Local Experts Model* (IMLEM)" (Scarpel and Milioni 2007, cited in Scarpel 2013). The IMLEM model integrates the parameter estimations for the partition of the input space and the training phase. This is done in such a way that the model's input space is simultaneously partitioned. Also, the best expert is identified so as to improve the fitting and the model's forecasting performance (Scarpel 2013, p. 36).

In a further modelling approach, Scarpel (2013) introduced the *Mixture of Local Experts Model* (MLEM) in his study forecasting airline passengers at Brazil's, São Paulo International Airport. Jacobs et al. (1991) introduced the mixture of local experts model (MLEM) approach in 1991. The authors argue that the MLEM approach is an ideal solution for addressing a complex problem. This is achieved by essentially dividing it into simpler problems whose solutions can be combined to yield a better one (divide-and-conquer principle). A unique feature of the MLEM is that it is actually built in stages (Scarpel 2013, p. 35).

According to Scarpel (2013, p. 35), these MLEM development stages are:

- The input space is divided into regions or clusters
- Train all of the models (experts) in each of the clusters
- Identify the best expert for each cluster
- Implement a composition of the local experts using a gating function that decides how to weight the local expert output for a given input point (Scarpel 2013, p. 35).

Scarpel (2013, p. 35) reported that “with this approach, the partition of the input space, the training phase and the composition of the local experts are performed sequentially in such a way that the results achieved in any step are adopted in the following steps”.

In addition to the above models, other new quantitative forecasting methods, predominantly artificial intelligence (AI), have emerged in the air travel demand forecasting literature. Artificial intelligence-based modelling techniques have become more popular in diverse disciplines over the past decade (Song & Li 2008). This growing popularity in their use is due to their robustness, high predictive capabilities, as well as their flexible behaviours to handle the multi-objective criteria in a straightforward manner (Yetilmezsoy et al. 2011). Historically, artificial intelligence-based techniques derived from rule-based and logic-programmed systems. However, the more recent contemporary interest in this forecasting approach has focused on the precise heuristic methods (Song & Li 2008). The most notable being fuzzy logic, artificial neural networks (ANNs) and genetic algorithm (Toshinori 1998). The main advantage of artificial intelligence techniques are that they do not require any preliminary or additional information about data, for example, distribution and probability (Song & Li 2008, p. 212).

Profillidis (2000) introduced the *Fuzzy Linear Regression Model* to forecast airport demand at Rhodes Airport in Greece. The fuzzy linear regression model is a possibilistic method that can be used in the context of possibility theory. This modelling technique captures vague and incomplete knowledge by means of possibility distributions. According to Profillidis (2000, p. 96), “in fuzzy linear regression models, the difference between data and estimated values is assumed to form an ambiguity that is due to the system's structure”. However, Profillidis (2000, p. 96) model would appear to bring the ambiguity of the relationship back to the system coefficients. This approach provides one way to construct an accurate relationship, which enters directly into the model through the fuzzy coefficients (Profillidis 2000, p. 96).

While the traditional regression forecasting method has its own model assumptions and pre-defined underlying relationships between dependent and independent variables (explanatory) (Osborne & Waters 2002), *artificial neural network* (ANN) models are considered a superior forecasting method since no prior assumptions about underlying patterns in the data in the model development process are required (see, for example, Garrido et al. 2014; Pan et al. 2013).

In recent years, the use of ANNs has grown rapidly due to their ability of mapping any linear or non-linear functions. The primary advantage of an ANN over other forecasting methods is that the neural network equally well predicts the processes whose regular components have any distribution law, whereas most other forecasting methods are best suited for processes that possess a regular component that belongs to a specific class (clearly, the method of polynomial smoothing is best suited for processes with a polynomial regular component, the method of smoothing by Fourier series is best suited for processes with a periodic regular component and so forth). ANNs also have no associated data assumption requirements (Claveria and Torra, 2014; Kunt et al., 2011; Santos et al., 2014). A further advantage of ANNs is their ability to learn (Aizenberg, 2011; Mrugalski, 2013; Sineglazov et al., 2013). ANNs have now been applied for forecasting in a wide range of disciplines, including banking (Venkatesh et al., 2014), economics (Choudhary and Haider, 2012), energy demand prediction (An et al., 2014; Jarimillo-Morán et al., 2013; Tamizharasi et al., 2014), tourism demand forecasting (Claveria and Torra, 2014; Palmer et al., 2006), traffic accident prediction (Akgüngör and Doğan, 2009; Kunt et al., 2011), supply chain (Kochak and Sharma 2015), transportation (Jiménez et al., 2014), and water demand prediction (Behboudian et al., 2014).

It is important to note, however, that several studies have come to the opposite conclusion. For example, Makridakis & Hibon (2000) concluded that neural network forecasts were less accurate than damped trend forecasts and combined forecasts. Crone et al. (2011) found that neural network forecasts were comparably accurate to forecasts from established statistical methods in time series prediction, but not more accurate (p.657).

There have only been a few reported studies using artificial neural networks (ANNs) in air transport demand forecasting. The first reported study that proposed an ANN for forecasting air travel demand was by Nam & Schaefer (1995). The authors developed an ANN for predicting passenger traffic between the Republic of South Korea and the USA. Alekseev and Seixas (2002, 2009) developed neural network based forecasting models to predict the annual Brazilian air transport passenger demand. Kim et al. (2003) forecasted the air travel demand changes of Seoul-Busan and Seoul-Daegu airline routes which they considered competitive with the high speed rail services (HSR). Ba-Fail (2004) forecasted the number of domestic and international airline passengers in Saudi Arabia using the neural network technique. Blinova (2007) examined the possibility of using a neural network approach to forecast the expansion of the air-transport network in Russia. In a further study, Chen et al.

(2012) employed a back-propagation neural network (BPN) to improve the forecasting accuracy of air passenger and air cargo demand from Japan to Taiwan.

In addition to ANNs, genetic algorithm is a further approach that can be applied for forecasting and optimization problems (Akgüngör & Doğan 2009; Kunt et al. 2011). Indeed, genetic algorithm (GA) is considered a powerful stochastic search technique and is based on the principle of natural evolution (Kunt et al. 2011). GA differs substantially from traditional optimization methods. This is because GA searches for the population of points in parallel rather than for a single point in order to obtain the best solution. Therefore, GA provides several potential solutions to a particular problem under study. The decision of the final solution is left to the user (Akgüngör & Doğan 2009).

The genetic algorithm approach has been applied to a wide range of disciplines in recent times, including electric energy estimation (Ozturk et al. 2005); energy demand prediction (Ghanbari et al. 2013); housing price forecasting (Gu et al. 2011); tourism demand forecasting (Hernández-López & Cáceres-Hernández 2007; Hong et al. 2011); tourism marketing (Hurley et al. 1998); traffic accident severity prediction (Akgüngör & Doğan 2009; Kunt et al. 2011); and transport energy demand prediction (Haldenbilen & Ceylan 2005). In addition, Sineglazov et al. (2013) have proposed a genetic algorithm approach for solving the problems of forecasting experienced in the aviation industry. The authors have also noted that their GA may be applicable to forecasting regional aviation facilities and other industrial sectors that have demand patterns similar to those experienced by airlines.

Another artificial based intelligence forecasting approach that is attracting considerable attention in the literature is the *adaptive network-based fuzzy inference system* (ANFIS). ANFIS was first introduced by Jang (1993). The Adaptive Neuro-Fuzzy Inference System (ANFIS) is a hybrid forecasting method comprising both fuzzy inference systems (FIS) with the artificial neural network (ANN) (Fang 2012; Liu et al. 2008). ANFIS is considered a more powerful approach than the simple fuzzy logic algorithm and artificial neural networks on their own. This is because the ANFIS technique provides a method whereby fuzzy modelling learns about the data set; in order to compute the membership function parameters which best enable the associated fuzzy inference system to track the given input/output data (Al-Ghandoor et al. 2012, p. 130). A further advantage of ANFIS is the fact that it can be trained without the requirement for the expert knowledge normally required for the standard fuzzy

logic design. Both quantitative data and linguistic knowledge can also be combined into a fuzzy rule base through the utilization of fuzzy methods. Furthermore, the strength of ANFIS is that it uses the artificial neural networks (ANNs) ability to classify data and identify patterns within data (Giovanis 2012). Moreover, ANFIS develops a fuzzy expert system that is more transparent to the user and which is also less likely to produce memorization errors than an artificial neural network (ANN) (Raşit 2009). Giovanis (2012, p. 88) also observes that other important advantages of ANFIS “include its nonlinear ability, its capacity for rapid learning, and its adaptation capability”.

This ANFIS approach has been applied to a growing range of disciplines, including transport mode choice (Andrade et al. 2007); economics (Fang 2012; Giovanis 2012); electricity demand forecasting (Zahedi et al. 2013); financial markets forecasting (Bagheri et al. 2014; Kablan 2009); gold price forecasting (Makridou et al. 2013); oil consumption forecasting (Senvar et al. 2013); stock market forecasting (Atsalakis & Valavanis 2009; Chen et al. 2013; Cheng et al. 2013; Svalina et al. 2013; Wei 2013); tourism demand forecasting (Atsalakis et al. 2014; Chen et al. 2010; Hadavandi et al. 2011); and ordering policy in supply chains (Latif et al. 2014). There has only been one published study using an ANFIS-based approach to model air transport demand forecasting (Xiao et al. 2014). Xiao et al. (2014) proposed a time series data-based neuro-fuzzy combination model, which was based on singular spectrum analysis, for the short-term air traffic prediction at Hong Kong International Airport.

Based on the preceding analysis of the air travel demand forecasting studies that were identified in the comprehensive literature review, Figure A5.3 shows that 55 studies or 87.3 per cent of the studies involved an econometric approach (regression-based), Five studies or 7.9 per cent used an artificial neural network (ANN) approach, whilst the adaptive neuro-fuzzy inference system (ANFIS), fuzzy model and Integrated Mixture of Local Experts Model (IMLEM) approaches, were 1.59 per cent, respectively.

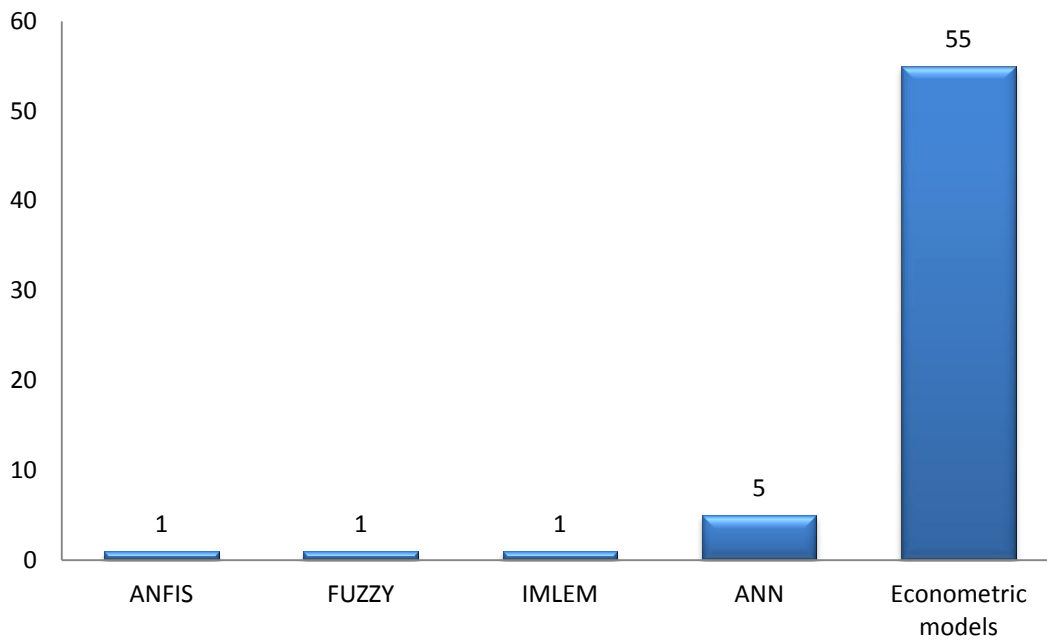


Figure A5.3. Summary of air travel demand modelling and forecasting studies forecasting approaches.

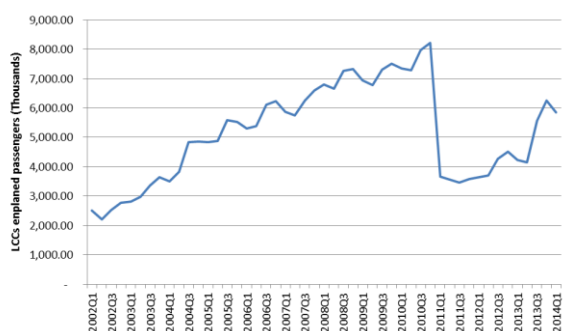
Legend:

Artificial neural network (ANN); Adaptive neuro-fuzzy inference system (ANFIS); Integrated mixture of local experts model (IMLEM).

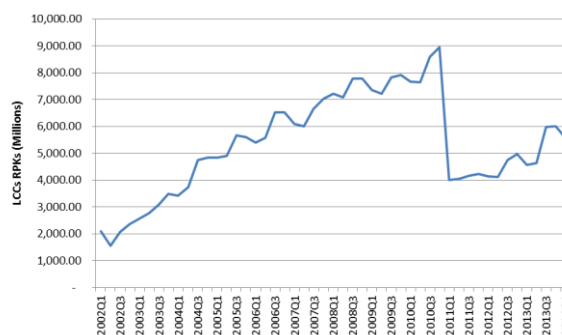
This section has presented the results of an extensive literature research, which found that 63 journal articles have been published on domestic and international air travel demand forecasting since the early 1950s. It has also identified how the air travel demand forecasting approaches have evolved over time, and, most importantly, highlighted that there have been no reported studies that have developed and tested genetic algorithm or artificial neuro-fuzzy inference system (ANFIS) for forecasting Australia's domestic LCC passenger demand.

APPENDIX 6 DATA TRENDS OF ALL VARIABLES

Figures A6.1 to Figure A6.10 plot the graphs for the two dependent variables (enplaned passengers and revenue passenger kilometres performed) and the eight independent variables included in the study. As we previously noted in Chapter 3, Australia’s domestic LCCs enplaned passengers and revenue passenger kilometres performed have decreased sharply since 2011. This decline can be attributed to the change in Virgin Australia’s business model from an LCC business model to a FSNC business model. The decline in both Australia’s domestic LCC enplaned passengers and RPKs can be clearly observed in Figures A6.1 and A6.2, respectively.



FigureA6.1. Australia’s LCCs enplaned passengers (Thousand)



FigureA6.2. Australia’s LCCs RPKs (Million)

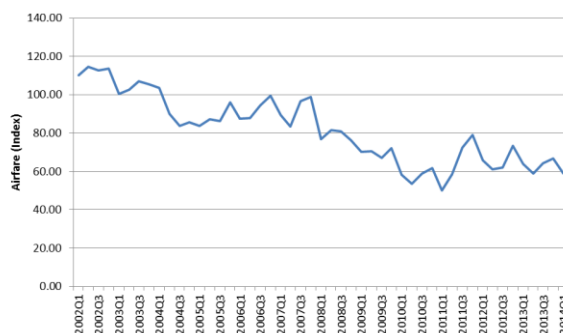


Figure A6.3. Australia’s real air fare (index)

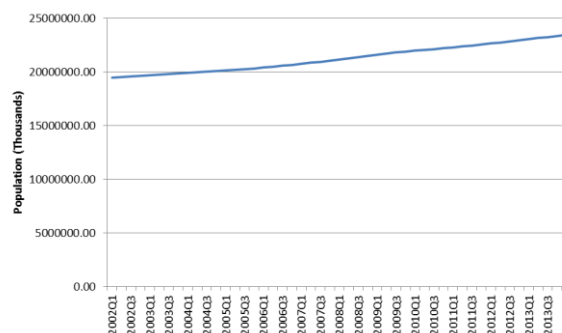


Figure A6.4. Australia’s population size (Thousand)

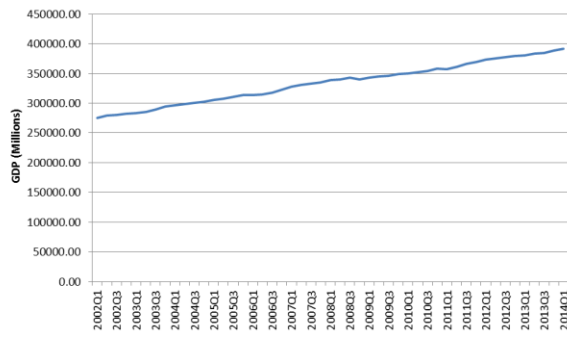


Figure A6.5. Australia's real GDP (Million)

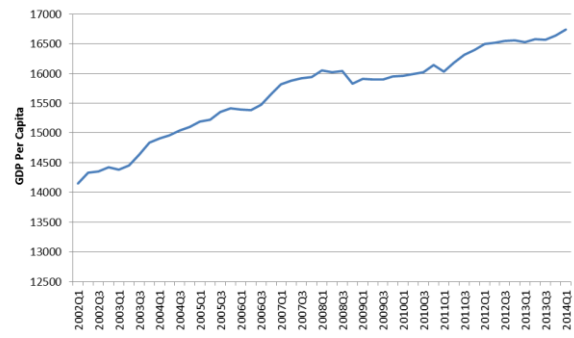


Figure A6.6. Australia's real GDP per capita

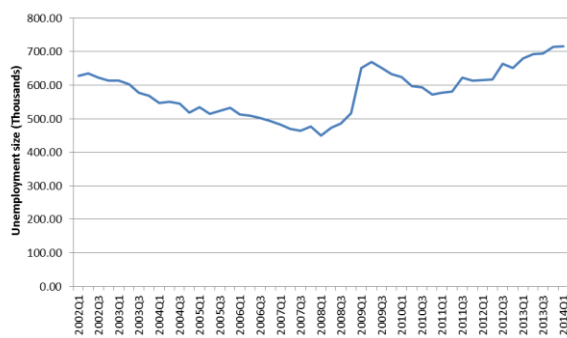


Figure A6.7. Australia's unemployment size (Thousand)

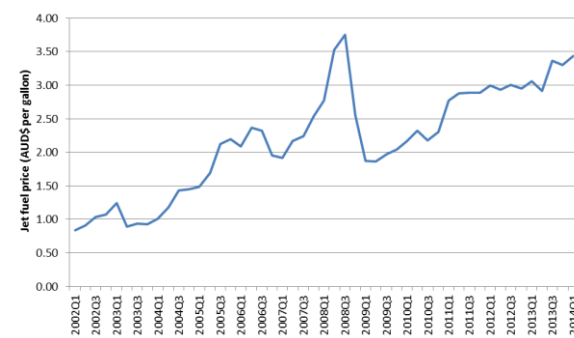


Figure A6.8. World jet fuel price (AUD\$ per gallon)

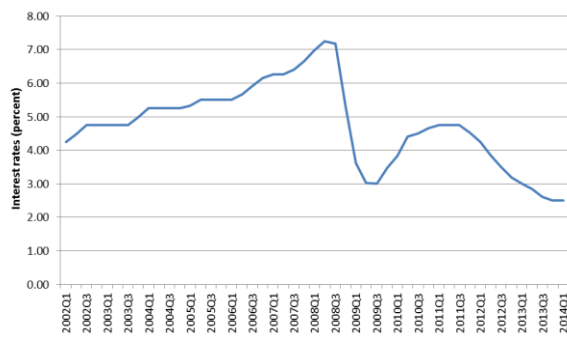


Figure A6.9. Australia's real interest rates (percent)

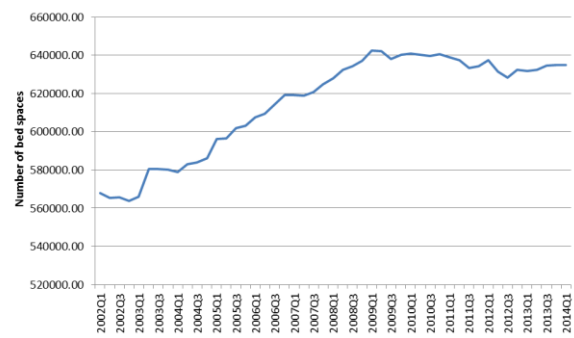


Figure A6.10. Australia's tourism accommodation capacity