



**Thank you for downloading this document from the RMIT Research Repository.**

The RMIT Research Repository is an open access database showcasing the research outputs of RMIT University researchers.

RMIT Research Repository: <http://researchbank.rmit.edu.au/>

**Citation:**

Sabatini, R, Richardson, M, Cantiello, M, Toscano, M, Fiorini, P, Jia, H and Zammit-Mangion, D 2012, 'Night vision imaging systems design, integration, and verification in military fighter aircraft', in Francis Berghmans, Anna Grazia Mignani, Piet De Moor (ed.) Proceedings of SPIE 8439, Optical Sensing and Detection II, Brussels, Belgium, 16-19 April 2012, pp. 1-26.

**See this record in the RMIT Research Repository at:**

<https://researchbank.rmit.edu.au/view/rmit:25786>

**Version:** Published Version

**Copyright Statement:**

© 2012 SPIE

**Link to Published Version:**

<http://dx.doi.org/10.1117/12.915720>

**PLEASE DO NOT REMOVE THIS PAGE**

# PROCEEDINGS OF SPIE

[SPIDigitalLibrary.org/conference-proceedings-of-spie](http://SPIDigitalLibrary.org/conference-proceedings-of-spie)

## Night vision imaging systems design, integration, and verification in military fighter aircraft

Roberto Sabatini, Mark A. Richardson, Maurizio Cantiello, Mario Toscano, Pietro Fiorini, et al.

Roberto Sabatini, Mark A. Richardson, Maurizio Cantiello, Mario Toscano, Pietro Fiorini, Huamin Jia, David Zammit-Mangion, "Night vision imaging systems design, integration, and verification in military fighter aircraft," Proc. SPIE 8439, Optical Sensing and Detection II, 84390R (9 May 2012); doi: 10.1117/12.915720

**SPIE.**

Event: SPIE Photonics Europe, 2012, Brussels, Belgium

# Night Vision Imaging Systems Design, Integration and Verification in Military Fighter Aircraft

Roberto Sabatini\*<sup>a</sup>, Mark A. Richardson<sup>b</sup>, Maurizio Cantiello<sup>c</sup>, Mario Toscano<sup>c</sup>,  
Pietro Fiorini<sup>c</sup>, Huamin Jia<sup>a</sup>, David Zammit-Mangion<sup>a</sup>

<sup>a</sup>Cranfield University – Department of Aerospace Engineering, Cranfield, Bedford MK43 0AL, UK

<sup>b</sup>Cranfield University – DAUK, Shrivenham, Swindon SN6 8LA, UK

<sup>c</sup>Italian Ministry of Defense – Air Staff, Rome 00185, Italy

## ABSTRACT

This paper describes the developmental and testing activities conducted by the Italian Air Force Official Test Centre (RSV) in collaboration with Alenia Aerospace, Litton Precision Products and Cranfield University, in order to confer the Night Vision Imaging Systems (NVIS) capability to the Italian TORNADO IDS (Interdiction and Strike) and ECR (Electronic Combat and Reconnaissance) aircraft. The activities consisted of various Design, Development, Test and Evaluation (DDT&E) activities, including Night Vision Goggles (NVG) integration, cockpit instruments and external lighting modifications, as well as various ground test sessions and a total of eighteen flight test sorties. RSV and Litton Precision Products were responsible of coordinating and conducting the installation activities of the internal and external lights. Particularly, an iterative process was established, allowing an in-site rapid correction of the major deficiencies encountered during the ground and flight test sessions. Both single-ship (day/night) and formation (night) flights were performed, shared between the Test Crews involved in the activities, allowing for a redundant examination of the various test items by all participants. An innovative test matrix was developed and implemented by RSV for assessing the operational suitability and effectiveness of the various modifications implemented. Also important was definition of test criteria for Pilot and Weapon Systems Officer (WSO) workload assessment during the accomplishment of various operational tasks during NVG missions. Furthermore, the specific technical and operational elements required for evaluating the modified helmets were identified, allowing an exhaustive comparative evaluation of the two proposed solutions (i.e., HGU-55P and HGU-55G modified helmets). The results of the activities were very satisfactory. The initial compatibility problems encountered were progressively mitigated by incorporating modifications both in the front and rear cockpits at the various stages of the test campaign. This process allowed a considerable enhancement of the TORNADO NVIS configuration, giving a good medium-high level NVG operational capability to the aircraft. Further developments also include the design, integration and test of internal/external lighting for the Italian TORNADO “Mid Life Update” (MLU) and other programs, such as the AM-X aircraft internal/external lights modification/testing and the activities addressing low-altitude NVG operations with fast jets (e.g., TORNADO, AM-X, MB-339CD), a major issue being the safe ejection of aircrew with NVG and NVG modified helmets. Two options have been identified for solving this problem: namely the modification of the current Gentex HGU-55 helmets and the design of a new helmet incorporating a reliable NVG connection/disconnection device (i.e., a mechanical system fully integrated in the helmet frame), with embedded automatic disconnection capability in case of ejection.

**Keywords:** Night Vision Imaging Systems, Night Vision Goggles, NVG Compatibility, Military Avionics.

## 1. INTRODUCTION

In recent years, the Italian Air Force set the requirements for Night Vision Imaging Systems (NVIS) to be integrated on TORNADO-IDS (Interdiction and Strike version) and ECR (Electronic Combat and Reconnaissance version) aircraft for operational missions at medium and high altitudes.

\*r.sabatini@cranfield.ac.uk; phone +44 (0)1234 758290; fax +44 (0)1234 758203; www.cranfield.ac.uk

An initial operational capability (operational certification for employment in peace-keeping operations) was achieved by RSV after a ground and flight test campaign (three ground sessions and six flight test sorties) conducted on modified aircraft interior and external lighting configurations, using the AN/AVS/9 (F4949) NVG manufactured by ITT-Night Vision. Successively, the full technical/formal process of avionics certification was undertaken under the direction of the Italian Ministry of Defense Aeronautical Armaments Certification Authority (Armaereo). The related flight test activities were conducted by the Italian Official Flight Test Centre with participation of the Alenia Flight Test Department. During the activity, Cranfield University provided technical advice regarding the mathematical models and analytic tools required for NVIS performance prediction and evaluation. The specific objectives of the TORNADO ground and flight test activities were the following:

- Internal and external lighting day and night evaluation with and without N/AVS/9 NVG (F4949);
- Workload assessment in single-ship and formation flights;
- Ergonomic and operational evaluation of the HGU-55P and HGU-55G modified helmets;
- N/AVS/9 NVG (F4949) cockpit stowage evaluation;
- Determination of the TORNADO-NVIS combination resolution characteristics;
- Determination, by ground tests and analysis, of the TORNADO-NVIS range performance.

After brief overview of NVIS technology, this paper described the DDT&E activities performed, with a special focus on cockpit design and ground/flight test methods developed and progressively refined throughout the activity.

## 2. NVIS TECHNOLOGY OVERVIEW

The Image Intensifier ( $I^2$ ) is the core element of NVIS systems.  $I^2$  devices are electro-optic systems used to detect and intensify reflected energy in the visible and near infrared regions of the electromagnetic spectrum. They require some external illumination in order to operate because the image quality is a function of the reflective contrast. The performances of  $I^2$  devices are also dependant on atmospheric and environmental conditions. Particularly, penetration through moisture can be quite effective (especially when compared to other Electro-Optic (EO) devices, like FLIR systems), while smoke, haze and dust can significantly reduce  $I^2$  performance. Signal-to-noise ratio (SNR) is the parameter commonly used to characterise  $I^2$  systems performance.

Generation I (GEN I) NVG's were introduced into service in the mid 1960's during the Vietnam War. They used starlight scopes based on electron acceleration (i.e., no micro channel plates). Therefore, they were characterised by high power requirements and tube gains between 40,000 and 60,000. Multiple staging, required to increase gain, often determined an increase of image distortion, and the overall systems were large/heavy (i.e., not suitable for head mount). Furthermore, GEN I systems were very susceptible to booming and the MTBF of a typical GEN I NVG was in the order of about 10,000 hours.

Generation II (GEN-II) NVG's were introduced in the late 1960's and they were small enough to be head mounted. They used electron multiplication (i.e., micro channel plate - MCP), with increased tubes gain, reduced power requirements, and reduced size/weight. Furthermore, the new  $I^2$  technology reduced distortion and blooming (confined to specific MCP tubules halos). Typical GEN-II systems were the AN/PVS-5 ground system, and the AN/AVS-5A system modified for aircraft usage. The MTBF of typical GEN-II systems was in the order of about 2000-4000 hours (worse than GEN I), the tube gain was approximately 10,000, and there was no inherent resolution improvement with respect to GEN I systems.

Improved photocathode performance, obtained by Gallium Arsenide (GaAs) components, determined a substantial improvement in spectral response with Generation III (GEN-III) systems. GEN-III matches night sky radiation better than GEN I and GEN-II systems, and can operate also in the absence of moon (starlight capability). Improved MCP performance were obtained by Aluminium Oxide coating, which decreases ion hits and increases MTBF (>10,000 hours). Today, GEN-III systems are widely used on most ground and in aircraft applications. Fig. 1 shows the relative responses of the GEN-II/GEN-III NVG systems and the human eye, together with the average night sky radiation [1, 2]. The improvement obtained with GEN-III NVG systems is evident.

As illustrated in Fig. 2, an I<sup>2</sup> device is typically composed by the following elements:

- Objective Lens
- Minus Blue Filter
- Photocathode
- Ion Barrier Film
- Microchannel Plate
- Phosphor Screen
- Image Inverter
- Eyepiece Lens

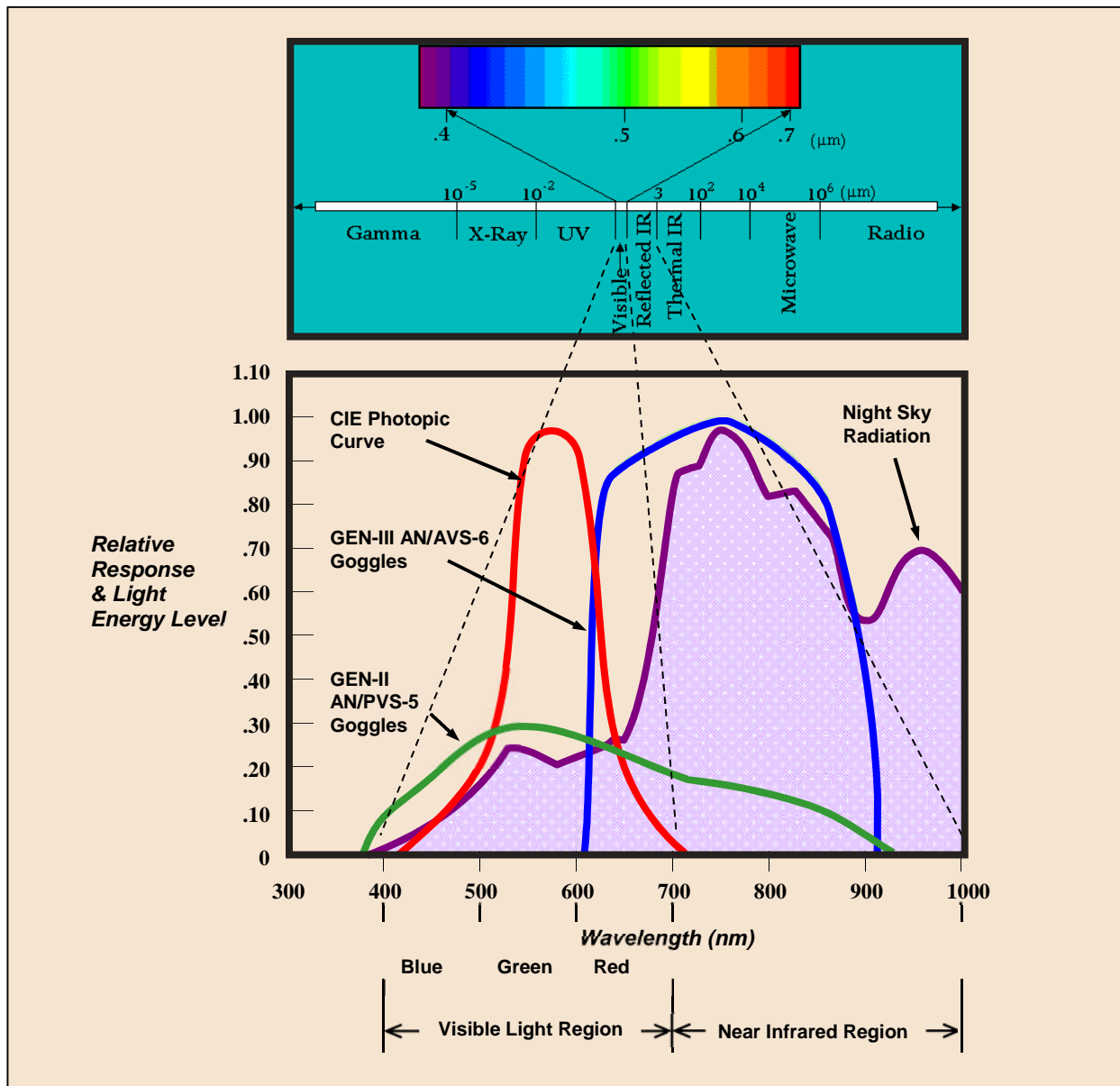

Figure 1. Relative responses of NVGs and the human eye.

The Objective Lens combines the optical elements and focuses incoming photons onto the photocathode (inverted image). In most airborne NVG's, the Objective Lens is coated with a "minus blue" filter (necessary for compatible cockpit lighting). It focuses from several inches to infinity (depending on NVG). Particularly, in airborne applications, infinity focusing is used in order to obtain:

- NVG external viewing
- Look Under/Around NVG for cockpit and instrument viewing

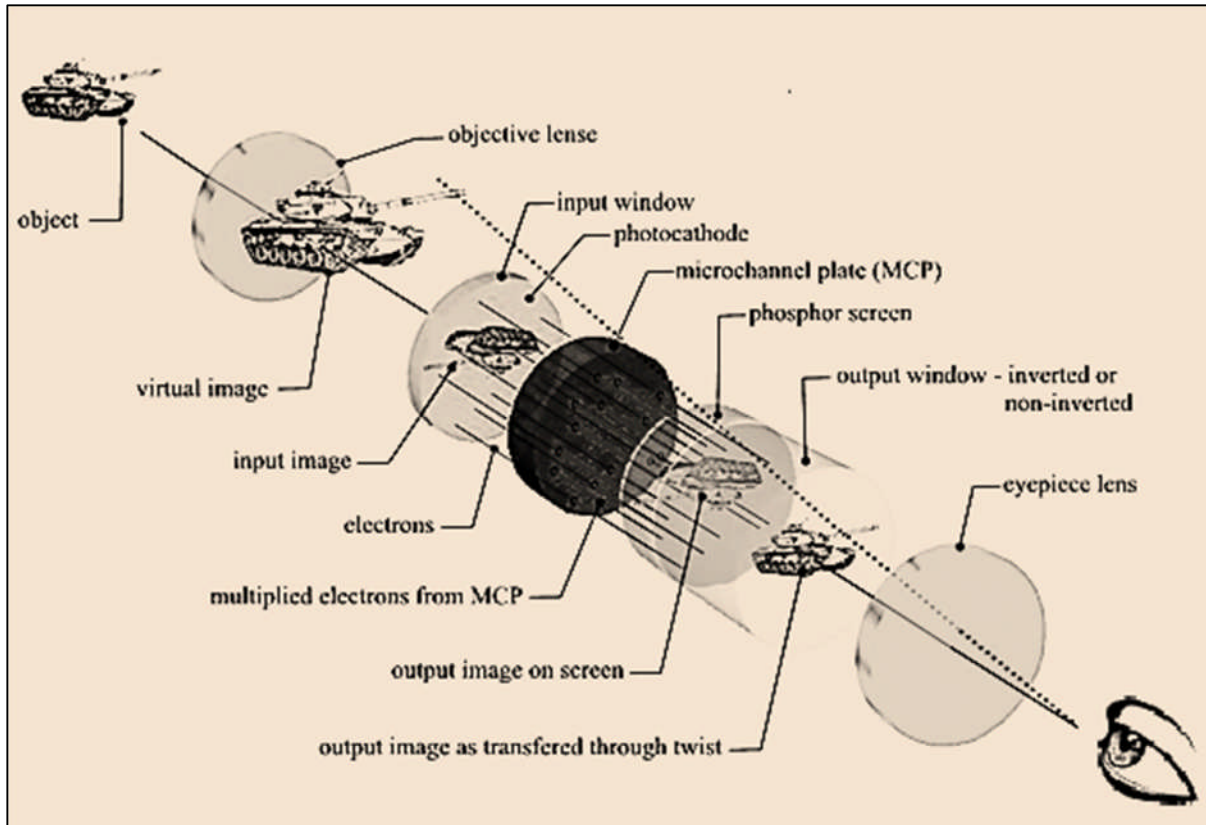

Figure 2. Architecture of an Image Intensifier, adapted from [1].

In airborne NVG's a "minus-blue" filter is coated inside the objective lens. Its purpose is to reject visible light and to prevent other specific wavelengths from entering the image intensifier. Therefore, it allows the use of properly emitting/filtered lighting to illuminate the cockpit for viewing underneath the goggles. There are three different classes of NVG objective lens filters:

- Class A: blocks below 625 nm (blue/green)
- Class B: blocks below 665 nm (blue/green/reduced red) - allows use of color displays
- Class C (leaky green) - incorporates notch cut-out to permit viewing of specific wavelength

The Photocathode (PC) converts light energy (photon) to electrical energy (electrons). The PC Inner surface is coated with a photosensitive material. Particularly, we list the following materials used in GEN-I/II and GEN-III systems:

- GEN-I/II: S-20 multi-alkali compound, sensitive between 400 and 850 nm (peak sensitivity at 500-600 nm);
- GEN-III: Gallium Arsenide (GaAs), sensitive from 600-900 nm (impact of photons cause release of electrons).

Typical PC responsivity figures are 250-550  $\mu\text{A}/\text{lm}$  for GEN-II systems and 1,000-1,800  $\mu\text{A}/\text{lm}$  for GEN-III systems. As illustrated in Fig. 3, GEN-III  $I^2$  tubes are fabricated with a so called Ion Barrier (IB) film. This film extends tube life (protects the PC) but reduces the system performance (i.e., degrades signal-to-noise ratio).

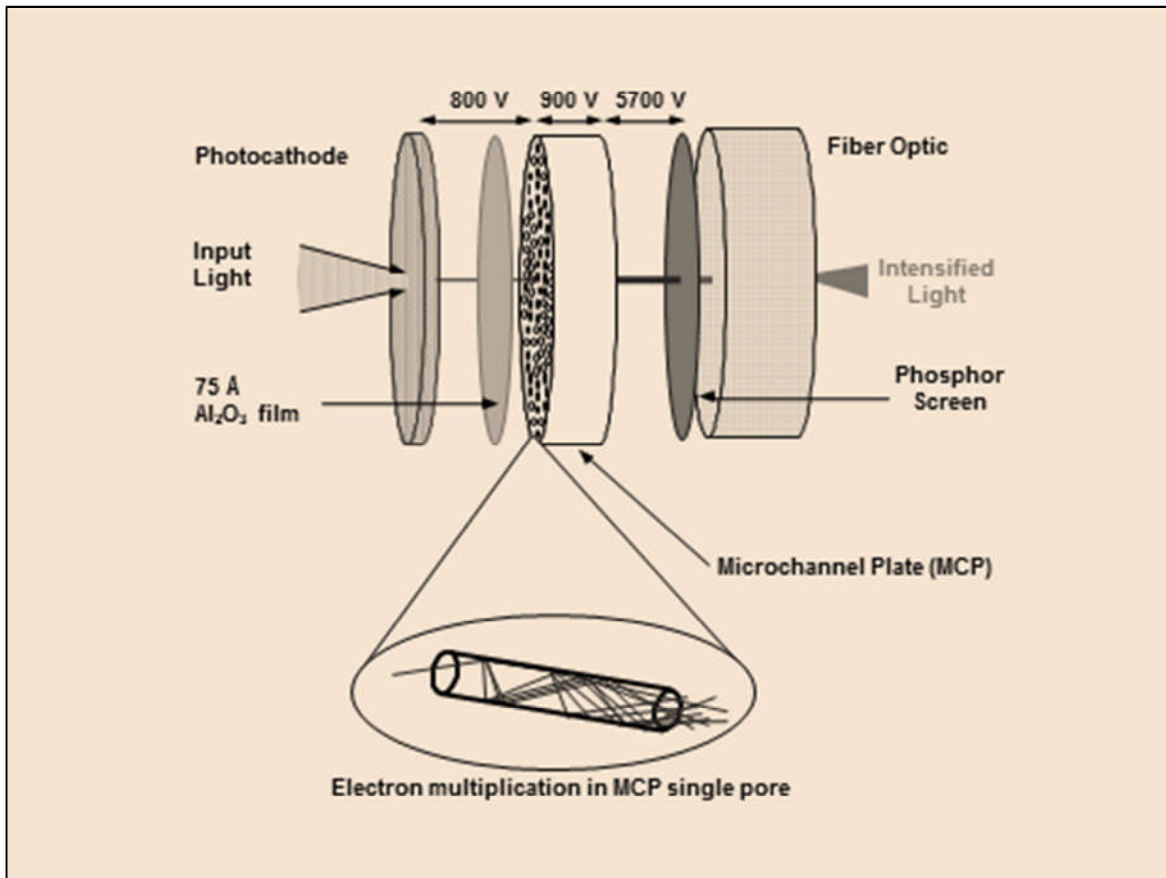

Figure 3. GEN-III  $I^2$  tube.

The Microchannel Plate (MCP) is a thin wafer (about 1mm) containing various millions of glass tubes or channels (typically 4-6 millions). Electrons from the PC enter the MCP tube (tube walls coated with lead compound rich in electrons) which is tilted (about 5 degrees) to ensure the impact of the electrons with the wall (Fig. 4). When an electron impacts the tube wall, more electrons are released resulting in a cascade process. Electrons are then accelerated towards the phosphor by an electrical potential differential (positive pole at phosphor). The ultimate output is number of electrons and their velocity. Resolution is a function of number of MCP tubes.

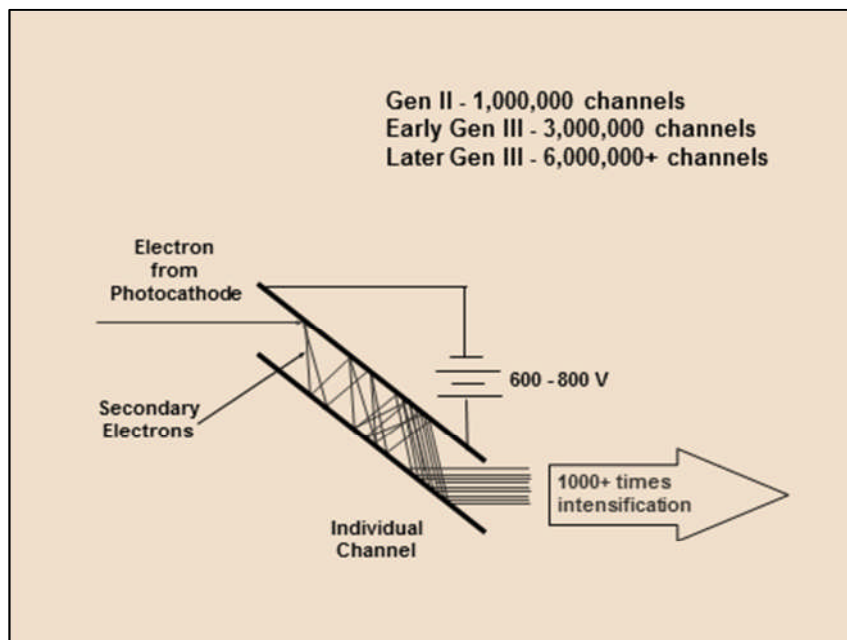

Figure 4. MCP working principle.

The Phosphor Screen (PS) is a thin layer of phosphor at the output of the MCP. Phosphor emits light energy when struck by electrons (electro-luminescence). Light emitted by phosphor creates a visible (green) image.

The Image Inverter (INV) is a bundle of millions of light transmitting fibers. The bundle rotates 180 degrees to reorient the image (fiber optic twist). It also collimates image for correct positioning at the viewer's eye. Problems in INV manufacturing and installation result in adverse image effects, such as distortion and honeycomb appearance. Some NVG designs do not incorporate a fiber optic twist for reorienting the image.

The Eyepiece Lens (EL) is the final optical component of the NVG. It focuses the visible image on the retina of the viewer and, generally, a limited diopter adjustment is allowed to permit some correction for individual vision variations. In general, corrective lenses must still be worn by users (the system does not correct for astigmatism). Most GEN-II systems have a 15mm eye-relief and a nominal 40° FOV. GEN-III systems typically have 25 mm nominal eye-relief which also provides the 40° FOV but enhances the ability to look under/around the NVG.

Signal to Noise Ratio (SNR) is a measure of image intensifier performance (resultant of the image intensification process). SNR for a NVG is defined as the ratio of electrons produced by ambient light (signal) to stray electrons (noise). Improved performance (larger SNR's) are produced by increasing the ambient light and/or improving the  $I^2$  (e.g., increasing PC sensitivity and decreasing the space between the elements).

### 3. NVIS COMPATIBILITY ISSUES

Intensified imagery of the outside scene is of primary importance to the aircrew. Incompatible light from cockpit sources and external lights are detected by the NVG and intensified, thus reducing the NVG gain. The resulting degraded image quality may not be readily apparent to the aircrew.

NVG compatible lighting results in instruments and displays being easily read with the unaided eye at night. However, all instruments must still be readable during day. NVG compatible lighting is often invisible to the NVG, while "friendly" lighting may be visible to the goggles, but without changing the gain state of the goggle. Typically, NVG compatible instruments and displays only emit wavelengths to which the eye is most responsive (i.e., little red and no near-IR emission).



There are basically two different implementation methods which can be adopted for integrating NVG compatible lighting in the cockpit. These methods are the following:

- Permanent lighting. Including integral instrument/display lighting, post and bezel lighting, foot lighting using existing aircraft light fixtures or LED based light sources;
- Temporary lighting. Including chemical light sticks and Light Emitting Diodes (LED) wiring harness.

Also NVG compatible external lights have can be used in order to increase mission effectiveness, increase flight safety and decrease aircraft vulnerability (IR covert mode). Also in this case, there are basically two different approaches possible:

- Introducing new equipment. Including conventional/filtered, electro-luminescent and LED technologies;
- Retrofitting existing lights. Including filtering and modifying the existing light source.

Another important aspect to be considered with NVIS compatible aircraft developments, is the NVG-helmet integration. Particularly, the following are the main goals to be achieved:

- Reduce the NVG-helmet moment arms;
- Reduce the weight;
- Maximise usage of the available FOV (considering eye relief, exit pupil, etc.);
- Allow use of various types of visors (including laser protection visors).

#### 4. DESCRIPTION OF TEST ARTICLES

The test activities were carried out using the NVG mod. AN/AVS/9 F4949G (P/N 264359-8) produced by ITT-Night Vision (Fig. 5). This is a GEN-III NVG, with class B filter and 40° nominal Field-of-View (FOV).

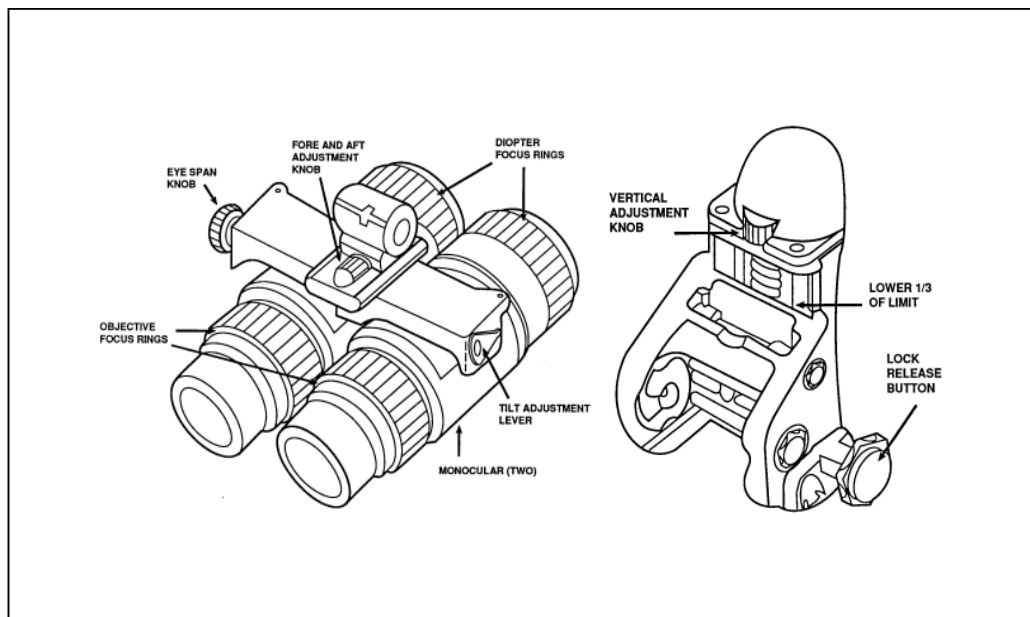

Figure 5. NVG mod. AN/AVS/9 F4949P (courtesy ITT Night Vision).

The goggles were installed on both the Gentex HGU-55/G and HGU-55/P standard helmets, using the ITT Night Vision helmet modification kit NSN 5340-01-442-641 as illustrated in the Figures 6 and 7.

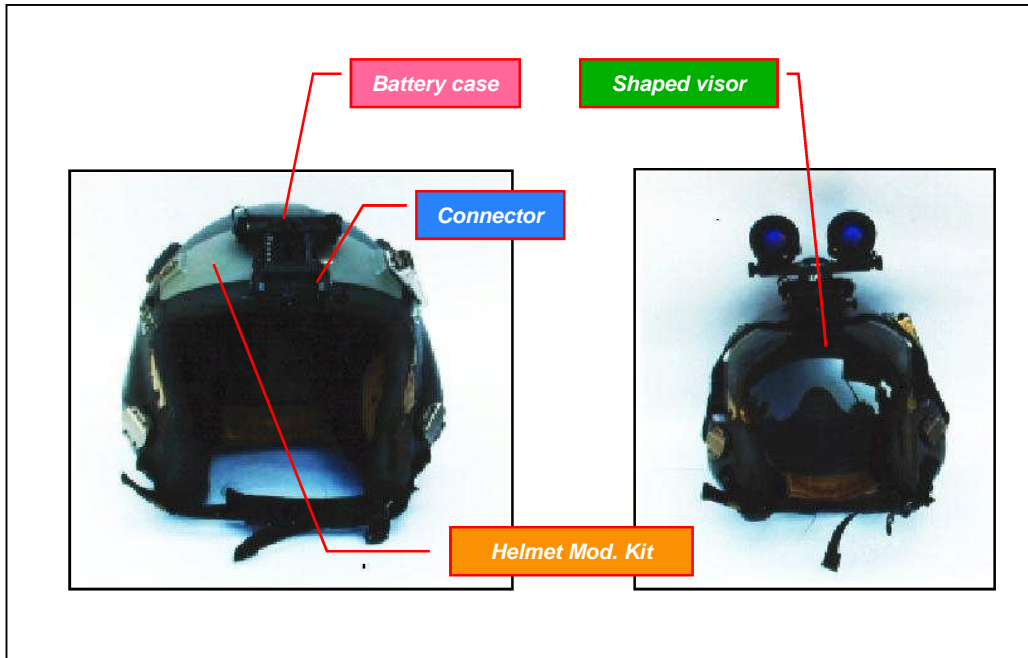

Figure 6. Modified HGU-55/P helmet with NVG installed.

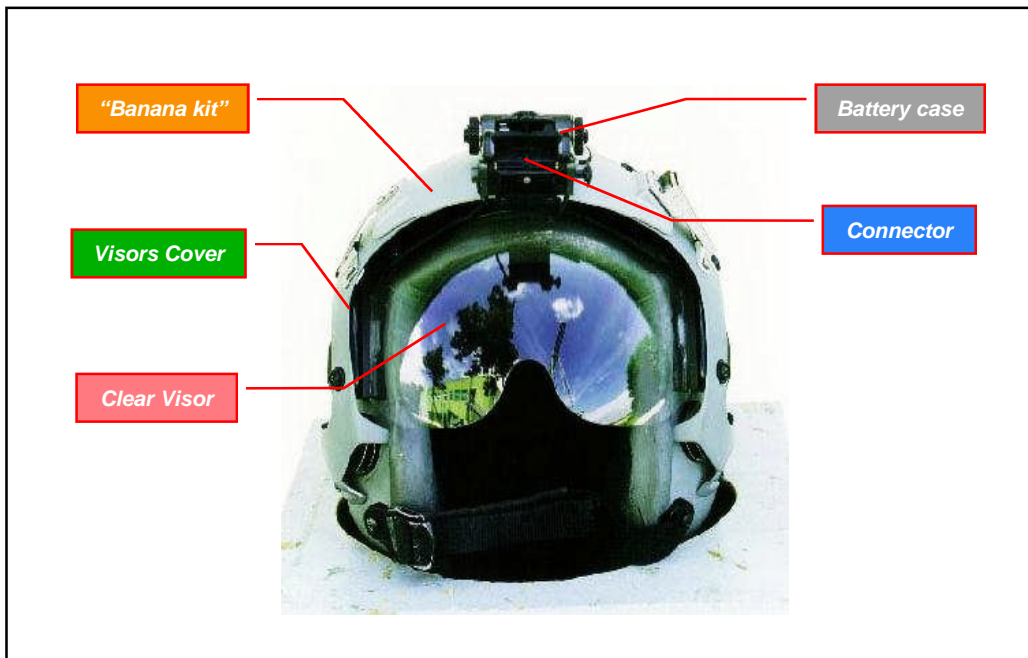

Figure 7. Modified HGU-55/G helmet with NVG installed.

The great majority of the TORNADO IDS/ECR cockpit displays, control panels and lights were modified by filtering or substituting the existing light sources, in order to obtain NVG compatible emissions. Also the aircraft external lights were modified, introducing an NVG friendly (IR emission) functional mode, and adding new functionalities in to the already existing visible lights. The new functionalities incorporated into the aircraft external lighting system are described in Figure 8.

Control Panel Setting				VIS Emission			IR Emission		
ON/OFF	BRIGHT/DIM	VIS/IR	CODE	Tail light	Wing tip	Intake	Tail light	Wing tip	Intake
ON	BRGT	VIS	C	PUNG	PUNG	PUNG	OFF	OFF	OFF
ON	BRGT	VIS	1,2,3,4	1,2,3,4	1,2,3,4	PUNG	OFF	OFF	OFF
ON	DIM	VIS	C	Steady (DIM)	Steady (DIM)	PUNG (DIM)	OFF	OFF	OFF
ON	BRGT	IR	C	OFF	OFF	OFF	PUNG	PUNG	OFF
ON	BRGT	IR	1,2,3,4	OFF	OFF	OFF	1,2,3,4	1,2,3,4	OFF
ON	DIM	IR	C	OFF	OFF	OFF	Steady (DIM)	Steady (DIM)	OFF

Figure 8. External lighting system functions .

Particularly, a new control box was installed in the cockpit allowing the pilot selection of the various external lights functional modes. Five different codes, all square wave in nature (codes 1, 2, 3, 4 and C in Fig. 8), were programmable in the control box (using an EPROM). One of these code was programmed with equal on and off times, while the other codes were programmed according to aircrew requirements, selecting code sequences with flash repetition frequencies and flash durations well discernible in flight.

During the flight test activities, after introducing a large number of modification into the TORNADO IDS/ECR front and rear cockpits, it was observed that certain areas of the front/rear main instrument panels and of the front/rear left and right consoles were not sufficiently illuminated by self-contained and/or general purpose cockpit lighting. Therefore, it was decided to test a ‘finger light’ both in the front and in the rear cockpits. The finger light FINGERSTAR (P/N 4790-NF-01A) used in the trials had both IR and visible emissions available, selectable by the operator using a finger-switch located on an adjustable (left/right hand) switching rail.

## 5. TEST AND ANALYSIS METHODS

An innovative test matrix was used for assessing the operational suitability and effectiveness of the various modifications implemented in the cockpit (Fig. 9). Particularly, both flight safety and operational effectiveness/suitability of the NVIS

configuration were considered in the test matrix, allowing an direct correlation between the flight test rating criteria and the standard evaluation rating scale used by RSV. This approach was applied both to the single modified items under test (displays, lights, panels, etc.), and to the overall cockpit NVIS configuration.

Modified aircraft external lights (both VIS and IR modes) were tested in formation flights (chase aircraft), performing the following tasks:

- Tactical Rejoin;
- Fighting Wing;
- Close and Battle Formation;
- Air-to-air Refueling.

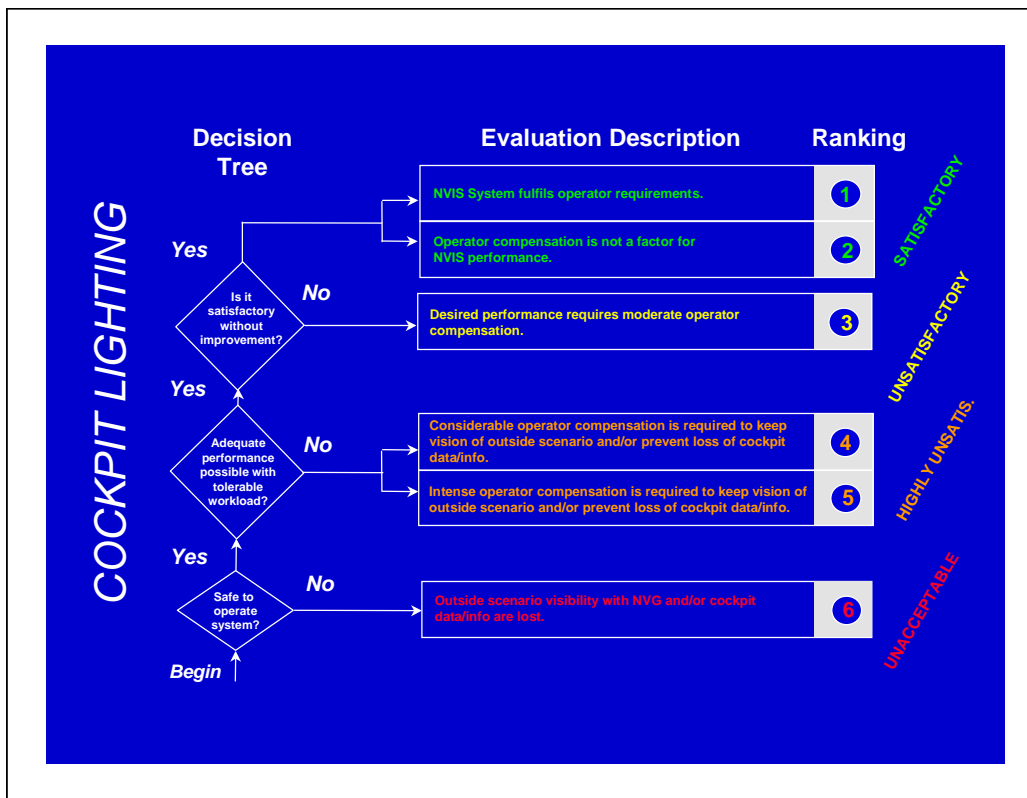

Figure 9. Cockpit evaluation test matrix.

Also important was definition of criteria for Pilot and WSO workload assessment during the accomplishment of various operational tasks during NVG missions (Fig. 10). Particularly, a workload evaluation matrix was implemented that allowed identification of the workload levels associated with the various Pilot and WSO operational tasks during real missions. These included ferry flights, attack, formation flights and tactical evasive/escape manoeuvres. The operational tasks considered were the following:

- Navigation;
- Automatic Flight Director System (AFDS) operation and monitoring;
- Engine/airplane systems operation and monitoring;

- Manual flight path control;
- Communications;
- Command decisions;
- Collision avoidance.

For each of the above tasks performed on the TORNADO NVG configuration, the levels of mental effort and physical difficulty, together with time required for the specific tasks and the understanding of horizontal/vertical position (spatial orientation) during execution of the tasks, were compared with the respective levels/values found for the standard TORNADO aircraft. Furthermore, the specific technical and operational elements required for evaluating the modified helmets were identified, allowing an exhaustive comparative evaluation of the two proposed solutions (i.e., HGU-55P and HGU-55G modified helmets). These elements included: measurement of the available FOV and calculation of the Projected FOV Area Reduction (PFAR), weight/balance, comfort and stability, crew fatigue in low and high dynamics flights. Furthermore, the NVG connection/disconnection devices were tested performing high dynamics manoeuvres (with NVG both in the up-locked and down-locked positions).

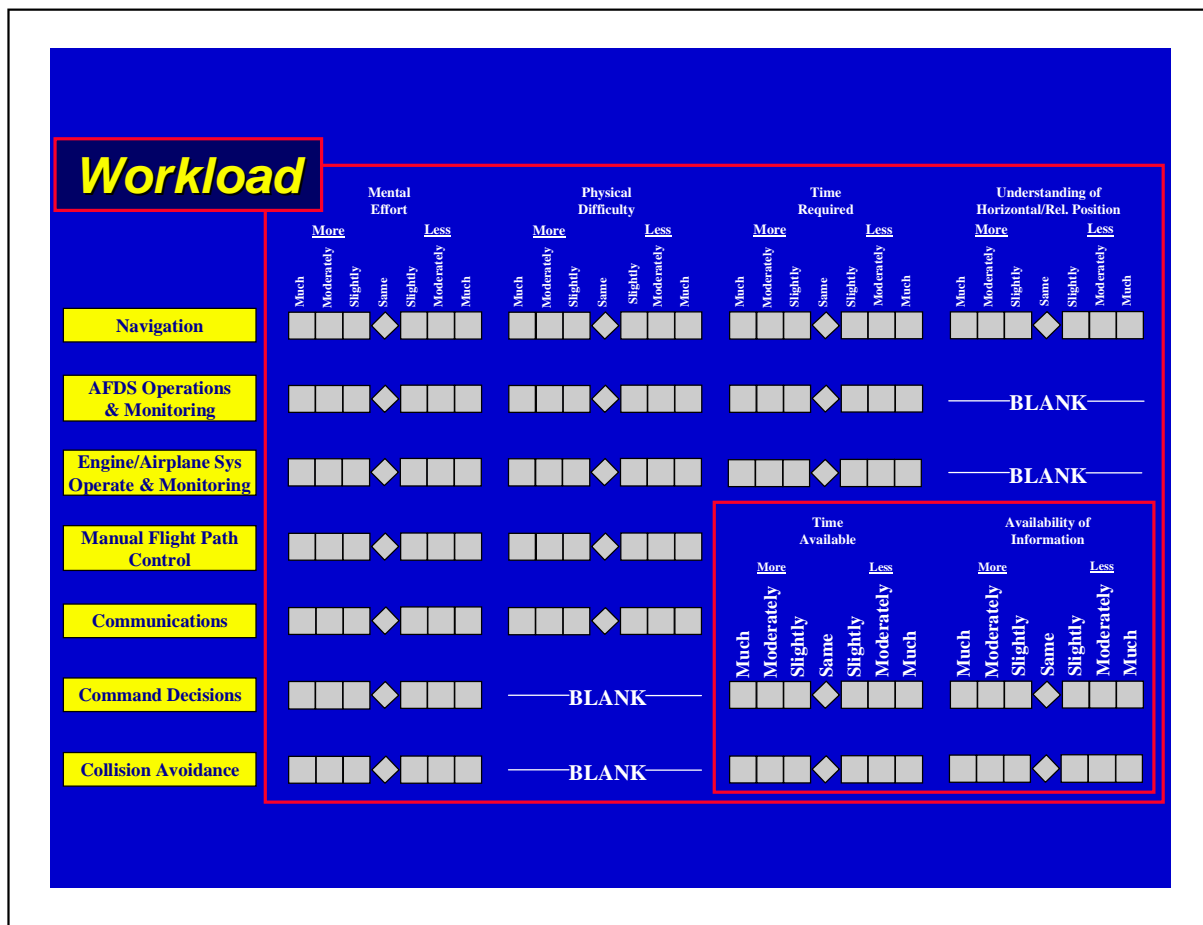

Figure 10. Workload evaluation matrix.

In order to assess the operational suitability of the modified HGU-55/P and HGU-55/G helmets, the related test activities focused on the following aspects:

- Measurement of the available Field-of-View (FOV) with minimum eye-relief;

- Determination of the minimum Projected Area FOV reduction (P-FOV);
- NVG helmets fitting and stability;
- Clearance with a/c structure (NVG up-locked and down-locked);
- Fatigue in low dynamics flight;
- Fatigue in maneuvering flight;
- Possible use of protection visors.

The spatial resolutions obtainable with the F4949 visors in the various sectors of the TORNADO canopy (normal sectors for external clearing), were also measured. This was done by using the USNTPS 20/20 – 20/70 resolution bars method [3]. Particularly, a resolution table was prepared (Fig. 11), composed of 16 groups of bars with dimensions and spacing corresponding to visual acuities between 20/70 and 20/20. The resolution bars table was illuminated with an artificial light source reproducing typical night illumination conditions.

During a ground test, using the bars target shown in Fig. 11, together with the low illumination lamp, the spatial frequencies (cycle/mrad) corresponding to various 2-D discrimination levels were determined for the F4949 system used on TORNADO, in the various sectors of the aircraft canopy. Using these experimental data it was possible to calculate the detection, recognition and identification ranges of the NVG system, for targets of given aspect dimensions located in certain regions of the Pilot and WSO external clearing scanning patterns.

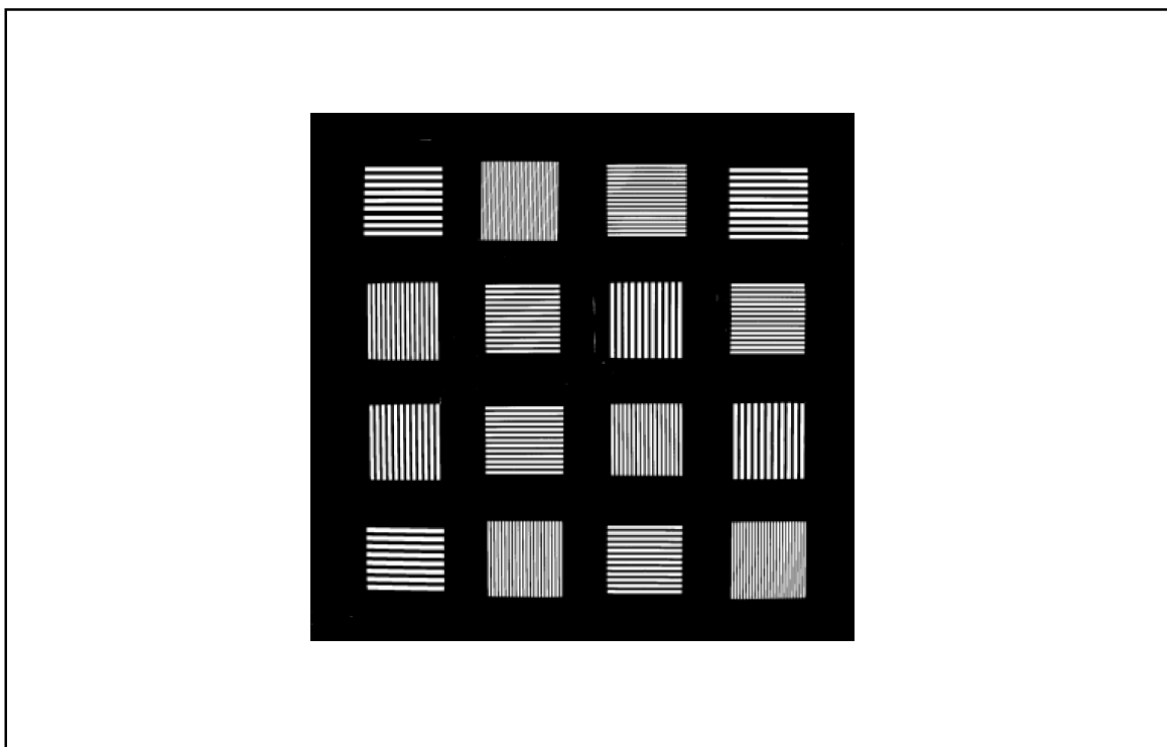

Figure 11. Resolution table (20/70 – 20/20).

Before executing the on-board ground tests, a preliminary session was performed by the same aircrews (with NVG) positioned on the ground at a distance of 20 feet from the resolution table (illuminated by the low illumination lamp). In this condition, the groups of bars resolved were annotated. Also during successive the on-board session, the distance between the Pilot/WSO Reference Eye Positions (REP's) and the bars target was maintained to exactly 20 feet, and the

resolution table was rotated about the REP's as shown in Fig. 12. Particularly, the following Pilot/WSO sectors were considered:

- Max Rear (Field-of-Regard limit);
- Lateral Sector 90°;
- Lateral Sector 60°;
- Lateral Sector 15° - 30°;
- Pilot HUD (0° - 15°).

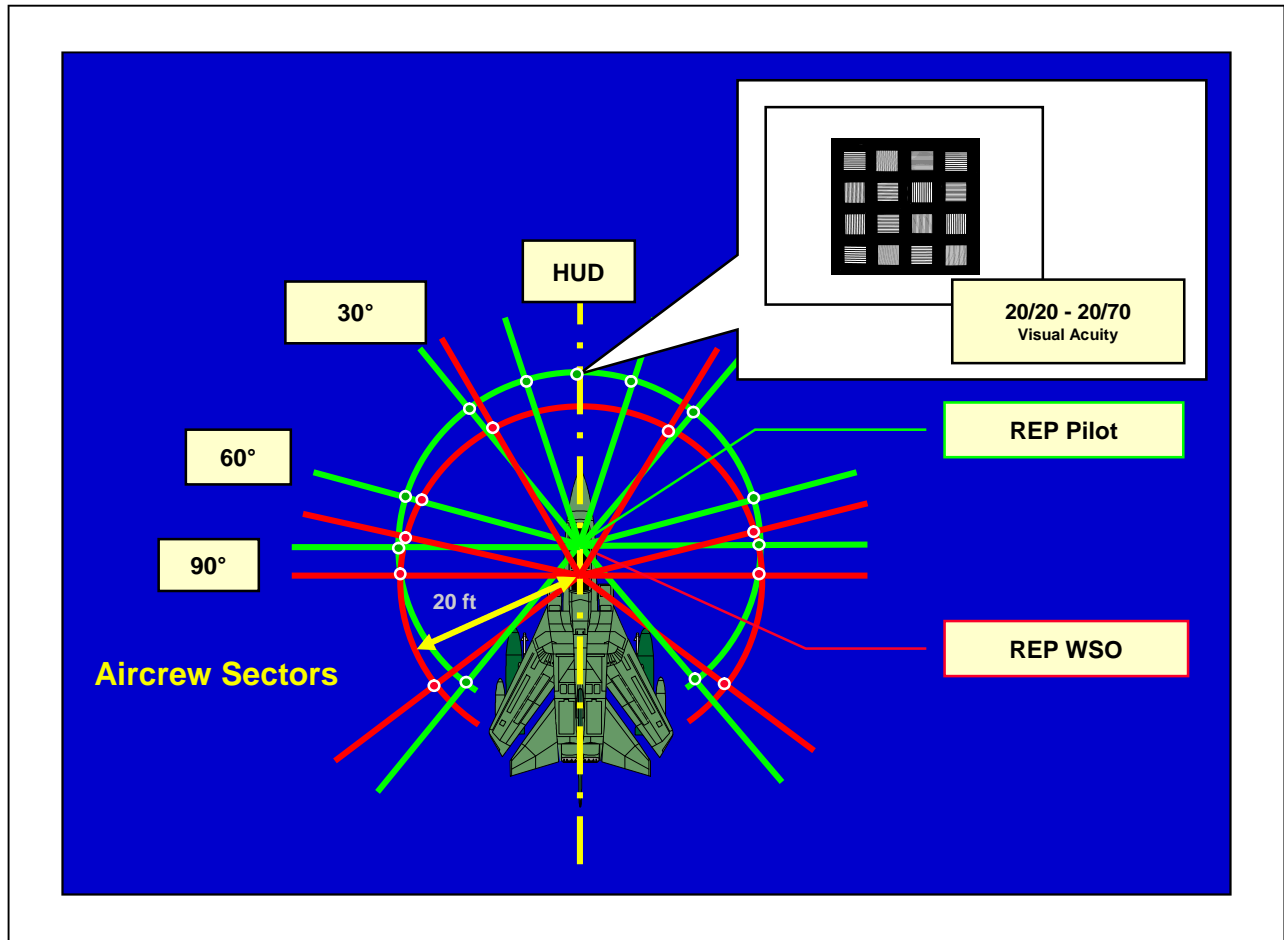

Figure 12. Geometry of resolution ground tests.

In each relevant position, the resolution target was rotated in four different positions as shown in Fig. 13. In each case, the Pilot/WSO abilities to resolve the various groups of bars were recorded.

NVG range performance predictions require a mathematical model that describes the eye/brain image interpretation process. Unlike the response of an electronic circuit, the response of a human observer cannot be directly measured but only can be inferred by many visual psychological experiments. The lowest level of discrimination is a distinction between something and nothing. The final level is the precise identification and description of a particular object. Between these two extremes lay a continuum of discrimination levels.

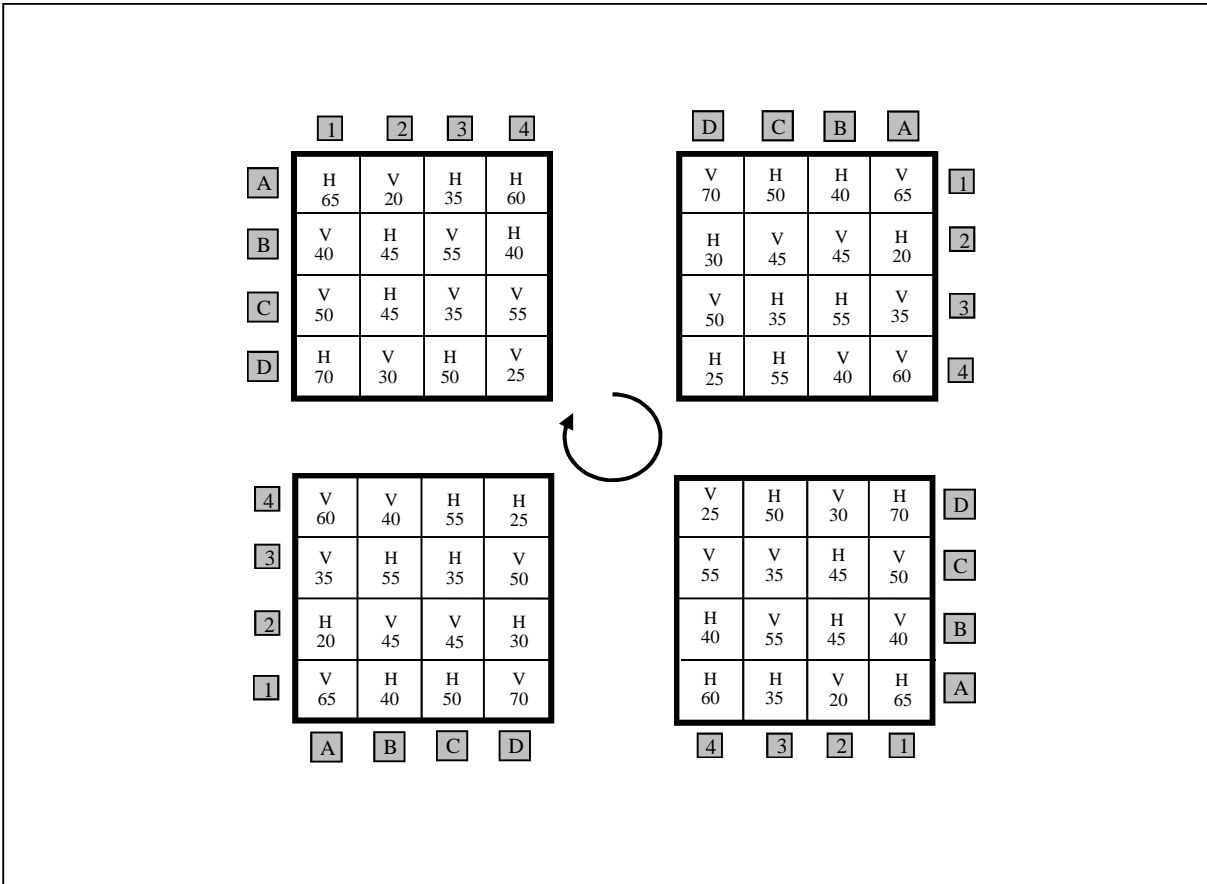

Figure 13. Resolution table positions for ground tests.

In the late fifties, Johnson studied image intensifiers discrimination performance at the US Army Engineering and Research Laboratories [2]. He arbitrarily divided visual discrimination into four categories: detection, orientation, recognition, and identification. Johnson's results allowed to correlate detectability with the sensor threshold bar pattern resolution (Table 1). In Johnson's work, the (angular) spatial frequency (SF) is defined as:

$$SF = \frac{R_T}{W_{1c}} \quad (1)$$

where:

$R_T$  = sensor-to-target range;

$W_{1c}$  = width of one cycle of target,

and the 'cycle' is defined as the sum of one bar and one space on the reference target. Johnson applied the number of cycles across the target minimum dimension, without regard to the orientation of the minimum dimension (his image intensifier imagery was radially symmetrical and therefore it was reasonable for him to ignore the bar orientation). Johnson's approach, known as the equivalent bar pattern approach, became the foundation for the discrimination methodology used today.



Table 1. Summary of Johnson's experimental results.

<b>Discrimination level</b>	<b>Meaning</b>	<b>Cycles across minimum dimension</b>
<b>Detection</b>	An object is present (object versus noise)	$1.0 \pm 0.025$
<b>Orientation</b>	The object is approximately symmetrical or unsymmetrical and its orientation may be discerned (side view versus front view)	$1.4 \pm 0.35$
<b>Recognition</b>	The class to which the object belongs (e.g., tank, truck, man)	$4.0 \pm 0.80$
<b>Identification</b>	The object is discerned with sufficient clarity to specify the type (e.g., T-52 tank, friendly jeep)	$6.4 \pm 1.50$

Successive studies and tests performed at the US Army Night Vision Laboratories and by industry suggested modifications to the values originally found by Johnson. Table 2 provides the current industry standard for one-dimensional target discrimination [3]. Orientation is a less popular discrimination level. Because current standards are based upon Johnson's work, they are labelled as the Johnson criterion though they are not the precise values found by him.

Table 2. Current industry criterion for 1-D discrimination (50% probability level).

<b>Discrimination level</b>	<b>Meaning</b>	<b>Cycles across min. dimension (<math>N_{50}</math>)</b>
<b>Detection</b>	An object is present	1.0
<b>Recognition</b>	The class to which the object belongs	4.0
<b>Identification</b>	The object is discerned with sufficient clarity to specify the type	8.0

The Johnson criterion provide an approximate measure of the 50% probability of discrimination. Results of several tests provided the cumulative probability of discrimination or target transfer probability function (TTPF). The TTPF can be used for all discrimination tasks by simply multiplying the 50% probability of performing the task ( $N_{50}$  in Table 2) by the appropriate TTPF multiplier in Table 3 [3].

Table 3. Discrimination cumulative probability.

Probability of discrimination	Multiplier $F_m$
1.00	3.0
0.95	2.0
0.80	1.5
0.50	1.0
0.30	0.75
0.10	0.50
0.02	0.25
0	0

For instance, the probability of 95% recognition is  $2N_{50} = 2(4) = 8$  cycles across the target minimum dimension. Similarly, the cycles required for detection, recognition and identification with a probability level of 80% are 1.5, 6 and 12 respectively. An empirical fit to the data provides [4]:

$$P(N) = \frac{\left(\frac{N}{N_{50}}\right)^E}{1 + \left(\frac{N}{N_{50}}\right)^E} \quad (2)$$

where:

$$E = 2.7 + 0.7 \cdot \left(\frac{N}{N_{50}}\right) \quad (3)$$

Visual psychophysical experiments suggest that the eye response follow a log-normal distribution [4]. The probability density function follows:

$$p(N) = \frac{1}{\sqrt{2\pi} \cdot \log(\sigma)} \cdot e^{-\frac{1}{2} \left[ \frac{\log(N) - \log(N_{50})}{\log(\sigma)} \right]^2} \quad (4)$$

where  $\log(\sigma) = 0.198$ . The cumulative probability is:

$$P(N) = \int_0^{\log N} p(N) d \log(N) \quad (5)$$

Both the empirical fit of eq. (3) and the log-normal approach (based upon a physically plausible foundation) of eq. (5) provide similar numerical results. As clutter increases, the ability to discern a target decreases. To account for this reduced capability,  $N_{50}$  must increase. Most studies have broadly categorised clutter into high, moderate and low regions, and defined the signal-to-clutter ratio (SCR) as:

$$SCR = \frac{\max \text{ target value} - \text{background mean}}{\sigma_{clutter}} \quad (6)$$

where:

$$\sigma_{clutter} = \sqrt{\frac{1}{N} \sum_{i=1}^N \sigma_i^2} \quad (7)$$

and  $\sigma_i$  is the rms value of the pixel values in a square cell that has side dimensions of approximately twice the target minimum dimension. The scene is composed of N adjoining cells. The use of adjoining cells introduces a spatial weighting factor that is similar to the spatial integration performed by the eye/brain process. Clutter sizes that are equal to the object size weigh more heavily in this calculation. The results are presented in Table 4 [6].

Table 4. TTPF when clutter is present.

Probability of detection	Multiplier $F_d$		
	Low Clutter SCR>10	Moder. Clutter 1<SCR<10	High Clutter SCR<1
1.0	1.7	2.8	**
0.95	1.0	1.9	**
0.90	0.90	1.7	7.0*
0.80	0.75	1.3	5.0
0.50	0.50	1.0	2.5
0.30	0.30	0.75	2.0
0.10	0.15	0.35	1.4
0.02	0.05	0.1	1.0
0	0.0	0.0	0.0

\*\* No data available. \* Estimated

Field experiments demonstrated that the Johnson detection criterion applies to a “general medium to low clutter” environment. Therefore, the 50% probability of detection in Table 4 where normalised in moderate clutter to one cycle. These experimental findings roughly follow the empirical TTPF of eq. (2). It is convenient to use 0.5, 1.0 and 2.5 as a multiplier ( $F_d$ ) to  $N_{50}$  for low, moderate, and high clutter environments respectively.

In order to obtain the two-dimensional discrimination levels required in a 2-D performance prediction model, each value in the one-dimensional criteria (Table 5) is multiplied by 0.75. The results are presented in Table 5.

Table 5. Discrimination levels for the 2-D model (50% probability level).

Discrimination level	Meaning	Cycles across minimum dimension ( $N_{50-2D}$ )
<b>Detection</b>	An object is present	0.75
<b>Recognition</b>	The class to which the object belongs	3.00
<b>Identification</b>	The object is discerned with sufficient clarity to specify the type	6.00

The US Night Vision Laboratory Static Performance Model [6] uses the minimum dimension (1-D), whereas most 2-D models refer to the object critical dimension [8]:

$$h_c = \sqrt{W_{TGT} \times H_{TGT}} \quad (8)$$

where  $W_{TGT}$  and  $H_{TGT}$  are the horizontal and vertical object dimensions. In this case, the number of cycles used for range performance calculations is that associated to the critical dimension  $h_c$ .

In conclusion, our 2-D range performance prediction model is summarised by the following equations:

$$R = \frac{h_c}{(N_{50-2D} \times F_d)} \times SF \quad \text{for detection} \quad (9)$$

$$R = \frac{h_c}{(N_{50-2D} \times F_m)} \times SF \quad \text{for recognition and identification} \quad (10)$$

where:

$R$  = predicted slant range;

$h_c$  = target critical dimension;

$SF$  = measured spatial frequency;

$N_{50-2D}$  = cycles required for detection, recognition and identification;

$F_m, F_d$  = multipliers for the various discrimination levels.

## 6. TEST RESULTS

The activities on TORNADO IDS and ECR both included various ground test sessions and a total of eighteen flight test sorties (7 night flights and 2 day flights for each aircraft type). RSV and Litton Precision Products were responsible of co-ordinating and conducting the installation activities of the internal and external lights. Particularly, an iterative process was established, allowing an in-site rapid correction of the major deficiencies encountered during the ground and flight test sessions. Both single-ship (day/night) and formation (night) flights were performed, shared between the Test Crews involved in the activities (Test Pilots/WSOs), allowing for a redundant examination of the various test items by all participants.

The technical results of the activity were very satisfactory. Particularly, the internal lighting compatibility problems were progressively mitigated by incorporating modifications both in the front and rear cockpits at the various stages of the development test program. This process allowed a considerable enhancement of the TORNADO cockpits NVIS configurations, giving a good medium-high level NVG operational capability to the aircraft. The Air Force Operational Certifications for both the IDS and ECR aircraft configurations were achieved by 2002. Fig. 14 shows the initial and final results of the overall cockpit evaluation.

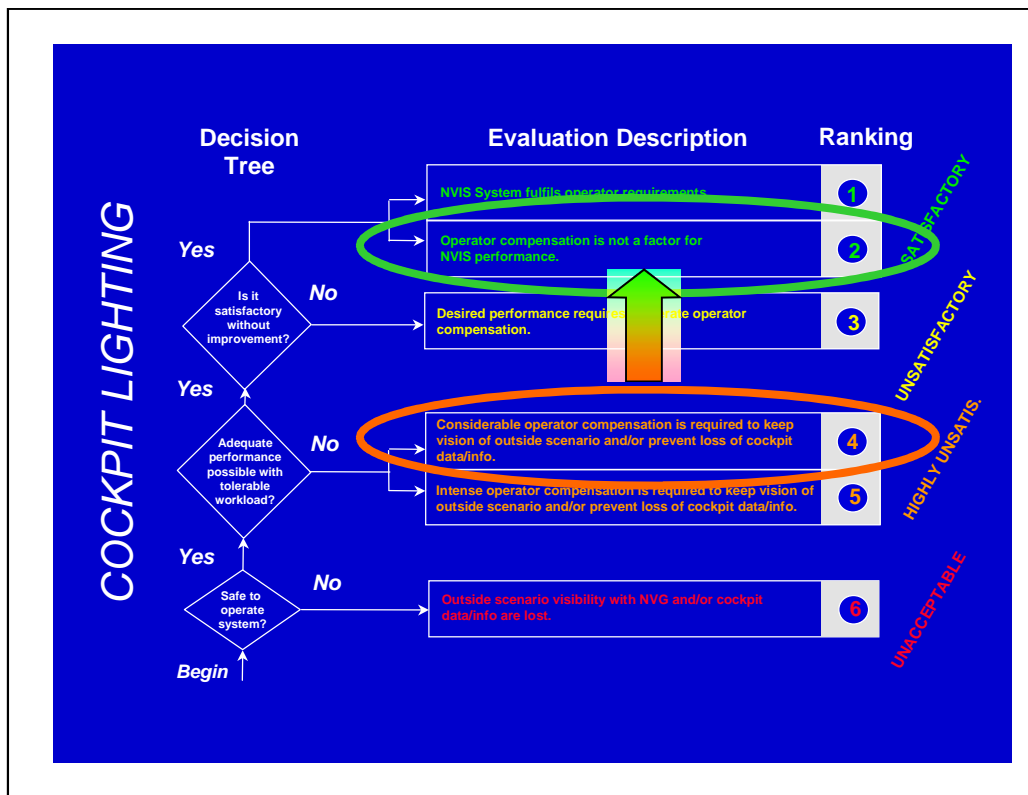

Figure 14. Results of the cockpit evaluation.

All external lighting modifications incorporated into the aircraft were satisfactory. Particularly, all medium-high level flight tasks required were performed successfully, after an adequate level of aircrew training. Close formation flights were indeed some of the most demanding tasks during NVG operations, requiring an appropriate level of aircrew training in order to estimate other aircraft distance, attitude and speed (dept/distance perception is severely degraded by NVG).

The workload assessment also gave encouraging results, demonstrating that the modifications of the aircraft interior and exterior lighting increased the levels of Pilot/WSO situational awareness and therefore their ability to perform operational tasks in night conditions. Particularly, medium-high level navigation and communications tasks were performed without a significant increase of aircrew workload, while the increase of workload experienced in AFDS/Engine/Airplane Systems operation and monitoring was counterbalanced by the substantial reduction of workload experienced in manual flight path control, command decisions, and collision avoidance tasks (e.g., formation flights). Again, it was readily apparent during the tests, that aircrew training was the key to increase flight safety and operational effectiveness in NVG operations.

The results of the NVG-helmets ergonomic evaluation are summarized in Fig. 15. The modified HGU-55/G helmet was heavier and less stable/balanced than the HGU-55/P helmet, and also gave a reduced NVG FOV due to increased eye-relief. However, the HGU-55/P helmet was not suitable for operational use, due to difficulties in installing and removing

the clear/laser protection visors during night operations with NVG (flying with protection visors is required on TORNADO to protect the aircrew, in case of ejection, against windblast and canopy fragmentation).

HGU-55G	HGU-55P
<p><b>PROS</b></p> <p>Easy use of visor (protection during ejection against wind blast and canopy fragmentation)</p> <p><b>CONS</b></p> <p>Reduced adjust. capability</p> <p>Greater distance eye-lens:</p> <ul style="list-style-type: none"> <li>- Reduced FOV (<math>\geq 3^\circ</math>)</li> <li>- Additional disturbance</li> <li>- Increased arm (<math>&gt; \text{fatigue}</math>)</li> </ul>	<p><b>PROS</b></p> <p>Nominal full adjustment</p> <p>Full FOV (<math>40^\circ</math>) available</p> <p>No additional disturbance</p> <p>Reduced arm of the NVG (<math>&lt; \text{fatigue}</math>)</p> <p><b>CONS</b></p> <p>Difficult use of visor</p> <p>Laser visor currently not in use with the ITAF</p>

Figure 15. Results of helmets ergonomic evaluation.

Table 6 shows the experimental data relative to the NVG FOV and PFAR, obtained with the HGU-55/G and HGU-55/P modified helmets, used by an operator with average percentiles, wearing a medium size helmet and a medium size oxygen mask (similar results were obtained with operators having different percentiles).

Table 6. FOV e PFAR measurements.

FOV		Diff. FOV	PFAR		Diff. PFAR
HGU-55P	HGU-55G	1.98	HGU-55P	HGU-55G	10.14%
39.19	37.21		4.30%	14.44%	

Compared to the  $40^\circ$  nominal FOV of the F43949 system, it is evident that there was a decrease in FOV of about  $0.8^\circ$  for the HGU-55/P helmet, and of  $2.8^\circ$  for the HGU-55/G helmet (i.e., the HGU-55/P helmet gives a  $2^\circ$  increase of FOV due to a reduced eye-relief). With the same operator, the PFAR (i.e., reduction of imaged scene area covered by the NVG), was about 4% for the HGU-55/P and about 14% for the HGU-55/G. Therefore, there was a difference of about 10% in the area covered by the NVG between the two helmets.

Based on the F4949 design data (provided by ITT Night Vision), Fig. 16 shows the FOV calculated as a function of the eye-relief distance and the PFAR vs. FOV curve.

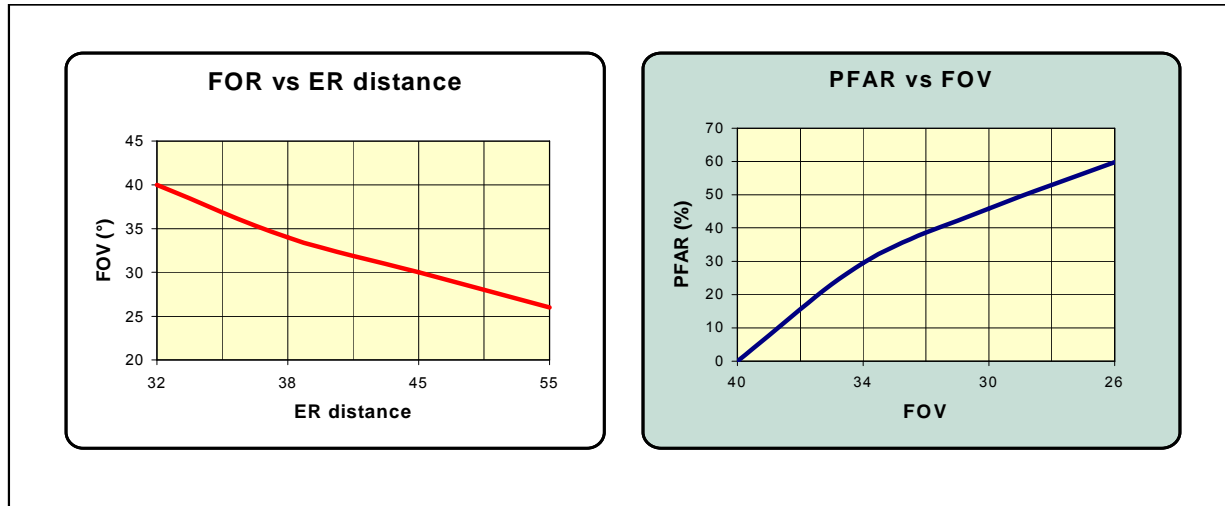

Figure 16. FOV vs. ERD and PFAR vs. FOV curves.

The experimental PFAR data (Fig. 17) were essentially coherent with the theoretical calculations. It is worth to underline that an ERD increase of 1 mm determines a 1° reduction in FOV, and an increase of the PFAR of about 5%. Compared to the ideal case of FOV=40°, this would equate to a 20% reduction of the area covered by the NVG for the HGU-55/G helmet, and of about 10% for the HGU-55/P helmet

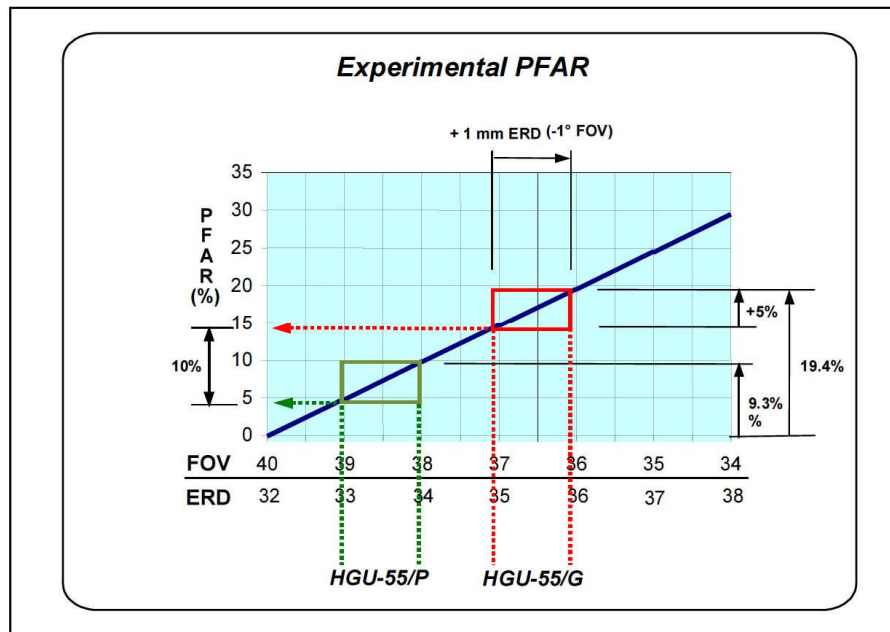

Figure 17. Percent variation of the PFAR as a function of ERD and FOV.

Based on visual acuity measurements results, the NVG detection, recognition and identification range performances were calculated using equations (9) and (10) in paragraph 5, for different types of targets. Particularly, the

detection/recognition/identification range performances were calculated with 80%, 90% and 100% probability levels. Furthermore, the detection performances (80%, 90% and 100% probability) were also calculated in low, medium and high clutter conditions. Examples of the results obtained are shown in Fig. 18.

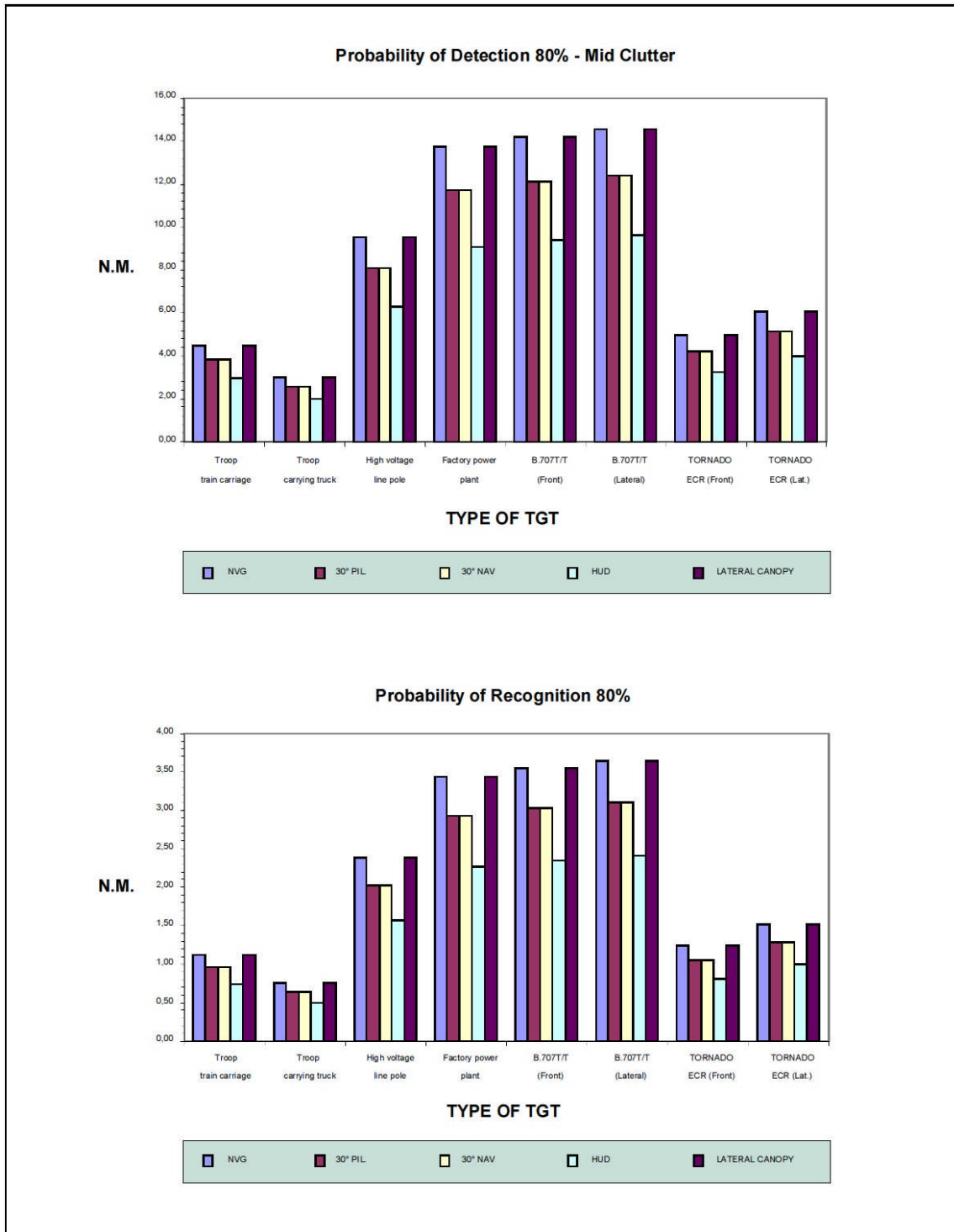

Figure 18. Results of NVG range performance calculations.



## 7. LESSONS LEARNED

The Human Factors risks in NVG operations are directly related to the quality of the interior and exterior aircraft lighting, the quality of aircrew training and the ability to detect and quantify under NVG. The most important technical and operational lessons learned during the TORNADO NVG flight test activities were the following:

- Unaided readability is just as important as NVG compatibility. NVG flight can be regarded as 'visually aided' instrument flight.
- A poor installation can spoil a good modification design (e.g., incompatible light leaks).
- Daylight readability may be more difficult after NVG modifications. Suppression of warning/caution indicators within the NVG FOV has to be avoided.
- The same design rationale for standard lighting applies to NVIS lighting.
- Standard lighting cannot be turned down enough to be NVG compatible.
- Partial modification is usually not successful. NVGs used for long periods may result in increased workload for aircrew.
- Properly designed NVIS lighting is usually superior to lighting it replaces. Particularly, it reduces reflections on canopies, it makes instruments easier to read at lower brightness levels, and reduces eye fatigue.

## 8. CONCLUSIONS AND FURTHER DEVELOPMENTS

In this paper we have described the development and testing activities conducted on the Italian TORNADO IDS/ECR in order to confer a medium-high level NVG operational capability to the aircraft. The TORNADO development activities, addressing the aircraft interior/exterior lighting and the helmet modifications (NVG integration), were conducted by RSV and supported by industry (Litton Presion Products). Also the ground and flight test activities were conducted by RSV, with participation of industry to the test flights (Alenia).

Particularly important for RSV was the clear identification of the technological alternatives available for aircraft modifications, as well as the definition of suitable test methods for both internal and external lighting evaluation. Also very important was the adoption of appropriate NVG performance analysis models, which led to the development of a standard PC based data analysis tool.

The technical results of the TORNADO NVG activities were very satisfactory. Particularly, the internal lighting compatibility problems were progressively mitigated by incorporating modifications both in the front and rear cockpits at the various stages of the development test program. This process allowed a considerable enhancement of the TORNADO cockpits NVIS configurations, giving a good medium-high level NVG operational capability to the aircraft.

The workload assessment also gave encouraging results, demonstrating that the modifications of the aircraft interior and exterior lighting increased the levels of Pilot/WSO situational awareness and therefore their ability to perform operational tasks in night conditions. However, it was readily apparent during the tests, that aircrew training was the key to increase flight safety and operational effectiveness in NVG operations.

The NVG-helmets tests allowed a comprehensive verification of the ergonomic and technical elements in favor or against each of the proposed solutions (i.e., modified HGU-55/G and HGU-55/P helmets). Overall, the HGU-55/P helmet was rejected due to difficulties in installing and removing the clear/laser protection visors during night operations, while the modified HGU-55/G was selected for TORNADO IDS/ECR operations (although not fully satisfactory).

In conclusion, a considerable experience was gained during the TORNADO NVG activities and further developments were launched in this area, taking advantage of the technical and operational lessons learned, to further increase the aircraft operational capability and safety.

Further developments currently ongoing in Italy, include the Alenia internal/external lighting design for the Italian TORNADO "Mid Life Update" (MLU) and various other Air Force programs, such as the AM-X aircraft internal/external lights modification/testing and other activities addressing low-altitude NVG operations with fast jets (e.g., TORNADO, AM-X, MB-339CD). A major issue encountered is the safe ejection of aircrew with NVG and NVG modified helmets. Two options have been identified for solving this problem: modification of the current HGU-55 helmets and the design of a new helmet incorporating a reliable NVG connection/disconnection device (i.e., a mechanical system fully integrated in the helmet frame), with embedded automatic disconnection capability in case of ejection. Other relevant issues to be accounted for in these new developments are the helmet dimensions and weight, the NVG usable FOV as a function of eye-relief distance, and helmet centre of gravity (moment arms) with and without NVG (impact on aircrew fatigue during training and real operational missions). A pictorial representation of the system initially proposed by Gentex and ITT Night Vision in order to match the Italian and German Air Forces TORNADO helmet requirements is shown in Fig. 19.

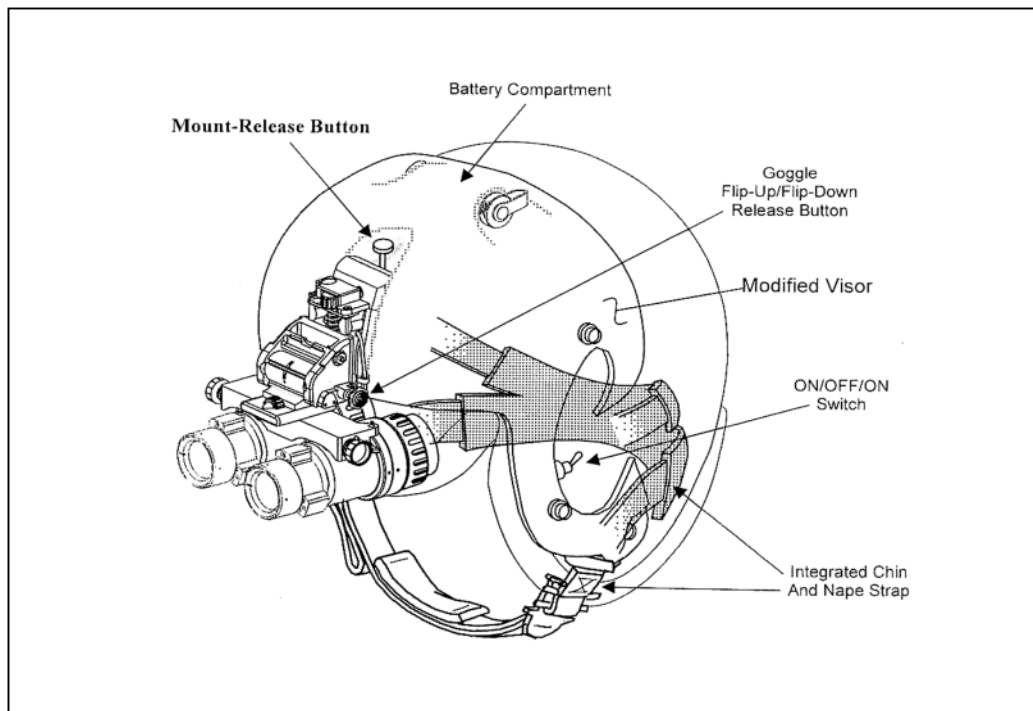

Figure 19. ITT/Gentex proposed NVG helmet for TORNADO (courtesy ITT Night Vision).

Further studies conducted by ITT-Night Vision and Gentex in collaboration with the Italian MoD, have defined the NVG-helmet solutions shown in the Figs. 20 and 21. Particularly, two different technical options have been identified: one which is based on the HGU-55/G helmet (Fig. 20) and another based on the HGU-55/P helmet (Fig. 21).

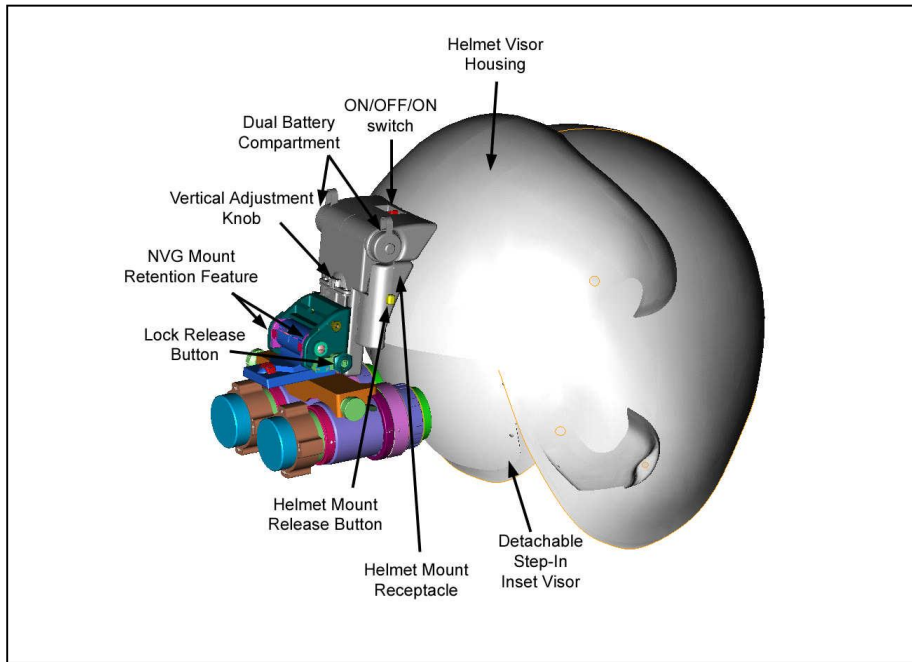

Figure 20. Proposed HGU-55/G NVG helmet (courtesy ITT Night Vision).

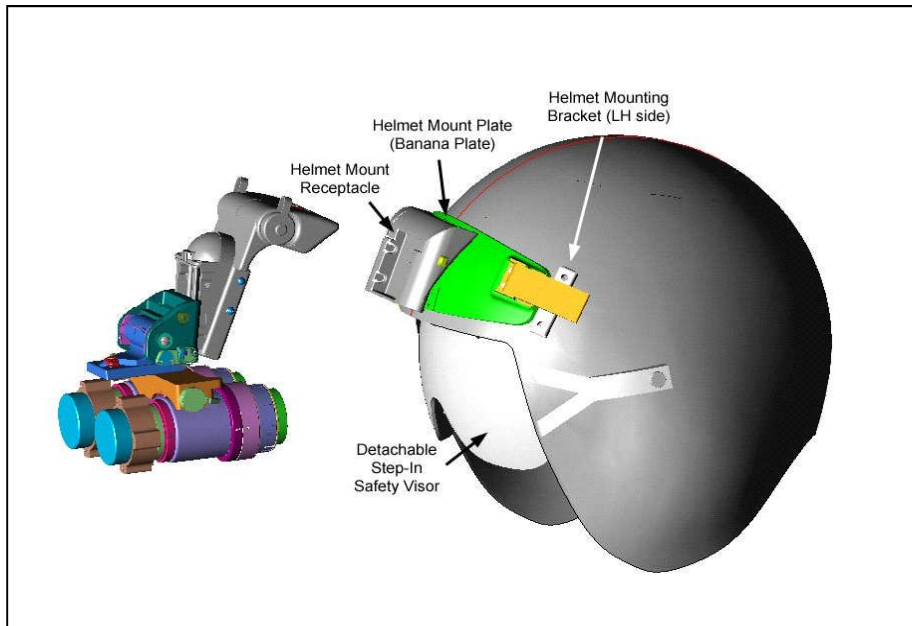

Figure 21. Proposed HGU-55/P NVG helmet (courtesy ITT Night Vision).

## 9. ACKNOWLEDGEMENTS

The authors would like to acknowledge the valuable contribution given by Alenia and Litton Precision Products, during the TORNADO IDS/ECR NVIS development and flight test activities. Great thanks go to the staff of RSV for strongly supporting NVIS programs. Last, but not least, the author wishes to thank the aircrews and technical personnel of the Alenia Flight Test Department. Thanks also go to all Air Force, Alenia, Litton, ITT and Gentex personnel not explicitly mentioned here, which supported in different ways the TORNADO NVIS development programs.

## REFERENCES

- [1] Overman C., "Electro-Optics 2002," Lecture Notes of the No. 35 GD Aero Systems Course, Royal Air Force Cranwell, Department of Air Warfare (2002).
- [2] Johnson J., "Analysis of Imaging Forming Systems," Proceedings of the Image Intensifier Symposium, pp. 249-273. Warfare Electrical Engineering Dept. - US Army Engineering Research and Development Laboratories (Ft. Belvoir, VA). 1958. This article was reprinted in "Selected Papers on Infrared Design", R.B. Johnson and W.L. Wolfe. SPIE Proceedings, Vol. 513, pp. 761-781 (1985).
- [3] Ratches J.A., "Static Performance Model for Thermal Imaging Systems," Optical Engineering Vol. 15(6), pp. 525-530 (1976).
- [4] Howe J.D., [Electro-Optical Imaging Systems Performance Prediction], Infrared and Electro-Optical Systems Handbook, Vol. 4 - Electro-Optical Systems Design, Analysis and Testing (Accetta J.S. and Shumaker D.L. Ed.), Environmental Research Institute of Michigan and SPIE Press (1993).
- [5] Holst G.C., "Applying the Log-normal Distribution to Target Detection". Infrared Imaging Systems: Design, Analysis, Modeling and Testing," SPIE Proceedings Vol. 1689, pp. 213-216 (1992).
- [6] Schmieder D.E. and Weathersby M.R., "Detection Performance in Clutter with Variable Resolution," IEEE Transactions on Aerospace and Electronic Systems, Vol. AES-19(4), pp. 622-630 (1983).
- [7] Ratches J.A., Lawson W.R., Orbet L.P., Begemann R.J., Cassidy T.W., and Swenson J.M., "Night Vision Laboratory Static Performance Model for Thermal Viewing Systems". ECOM Report ECOM-7043, Fort Monmouth, NJ (1975).
- [8] Holst G.C., [Electro-Optical Imaging System Performance], SPIE Optical Engineering Press, Bellingham, Washington USA (1995).