

Available online at www.sciencedirect.com

ScienceDirect

Energy Procedia 49 (2014) 1034 – 1043

Energy

Procedia

SolarPACES 2013

Thermochemical solar energy storage via redox oxides: materials and reactor/heat exchanger concepts

S. Tescari^{a*}, C. Agrafiotis^a, S. Breuer^a, L. de Oliveira^a, M. Neises-von Puttkamer^a,
M. Roeb^a, C. Sattler^a

^a German Aerospace Center (DLR), Linder Hoehe, Cologne 51147, Germany

Abstract

Thermochemical Storage of solar heat exploits the heat effects of reversible chemical reactions for the storage of solar energy. Among the possible reversible gas-solid chemical reactions, the utilization of a pair of redox reactions of multivalent solid oxides can be directly coupled to CSP plants employing air as the heat transfer fluid bypassing the need for a separate heat exchanger. The present work concerns the development of thermochemical storage systems based on such oxide-based redox materials and in particular on cobalt oxide; in the one hand by tailoring their heat storage/release capability and on the other hand via their incorporation in proper reactor/heat exchanger devices. In this respect the first stage of the work involved parametric testing of cobalt oxide compositions via Thermo-Gravimetric Analysis to comparatively investigate the temperature range for cyclic oxidation-reduction and optimize the cycle conditions for maximum reduction and re-oxidation extent. Subsequently, two reactor concepts for the coupling of solar energy to the redox reactions have been implemented and tested. These reactor concepts include in one hand structured ceramic reactors/heat exchangers based on redox-oxide-coated honeycombs and on the other hand powder-fed, solar-heated, rotary kiln reactors. The two reactor concepts were tested within non-solar-aided lab-scale and solar-aided campaigns, respectively. The feasibility of both concepts was shown and good chemical conversions were achieved. The experiments pointed out the challenging points related to the manufacture of pilot-scale reactors/heat exchangers with enhanced heat storage capacity. A numerical model using commercial CFD software is developed to define optimal geometrical characteristics and operating conditions and refine the pilot scale design in order to achieve efficient, long-term off-sun operation.

© 2013 The Authors. Published by Elsevier Ltd. This is an open access article under the CC BY-NC-ND license (<http://creativecommons.org/licenses/by-nc-nd/3.0/>).

Selection and peer review by the scientific conference committee of SolarPACES 2013 under responsibility of PSE AG.

Final manuscript published as received without editorial corrections.

Keywords: solar energy; thermochemical storage; redox oxides; cobalt oxide

* Corresponding author. Tel.: +49-2203-601-2402; fax: +49-2203-601-4141.
E-mail address: stefania.tescari@dlr.de

1. Introduction

Storage of solar energy is one of the challenges which could ensure the future development of Concentrated Solar Power (CSP) thermal plants. At present several commercial storage systems are available, storing the heat in its sensible form, using liquid [1, 2] or solid storage media [3-6]. The latter is the preferred heat storage type for central receiver power plants using air as a heat transfer medium. For instance, the Solar Tower power plant of Jülich (STJ) inaugurated in 2009 (Fig. 1a) uses an open volumetric receiver technology developed at DLR, in which the receiver consists of an array of ceramic honeycombs made of silicon carbide (SiC) (Fig. 1c) [7-9]. In its primary cycle, air at atmospheric pressure is heated up to temperatures of about 700°C; however, if needed, this temperature can be exceeded in future such plants with the same technology. This solar heat then powers a steam generator, producing steam at 100 bars and 500°C and driving a 1.5 MW_{el} turbine-generator set. In parallel to the steam generator and receiver, a sensible heat storage system is integrated into the power cycle, implemented as an air-cooled regenerator storage which the air is conducted transferring its enthalpy to a solid medium (Fig. 1b). With this storage type - used in several industrial applications - a gaseous heat transfer fluid, i.e. air, is in direct contact with a solid storage medium and exchanges heat as it flows along a flow-path through the storage medium. The storage solution, as finally realized, consists of a rectangular housing of 7m x 7m x 6m size (Fig. 1d), resembling an industrial Regenerative Thermal Oxidizer (RTO) implementation [6, 10]. Instead of pursuing a monolithic design, the storage is partitioned into four chambers of identical size, connected in parallel through a dome and connecting pipes. Each of the chambers is filled with an array of ceramic storage material formed in the shape of honeycombs to provide a large heat exchange surface between the air and the solid storage medium. The total volume of the inventory amounts to 120 m³. The full load discharge period of this sensible heat storage is limited to about 1.5 hours. At rated operation conditions, the storage system is cycled between 120 and 680°C, i.e. during on-sun operation “hot” air is supplied from the solar tower to the top of the storage medium at a temperature of approximately 680°C and exits at the bottom of the storage medium at a temperature approximately 120°C (Fig. 1b). During off-sun operation the air flow is reversed: “cold” air is introduced through the lower end of the storage medium to be heated by that as it flows towards the already “hotter” top end, before being introduced again to the power block. In principle, the technology is applicable to both atmospheric as well as pressurized systems.

One drawback of these systems is the large amount of storage material requested. This could be decreased by increasing the energy density of the storage medium. Several studies have shown that this increase can be reached by storing the energy as latent or thermochemical heat. Both these concepts are at an early research stage, but some installations have already shown their feasibility both for latent [11, 12] as well as for thermochemical heat storage [13-15]. ThermoChemical heat Storage (TCS) is based on reversible chemical reactions like the exemplary case of cobalt oxide shown below:



In the charging phase of the storage, solar heat produced during on-sun operation by a solar concentrator is used to power an endothermic chemical reaction, e.g. the forward reaction in (1). If this reaction is completely reversible the thermal energy can be entirely recovered by the reverse reaction during off-sun operation (discharging storage phase) and can be used to produce electricity. Several advantages characterize thermochemical heat storage: high energy density which allows a decrease of the storage unit volume and consequently of its heat losses; possibility of long-term storage as the reaction heat can be stored as long as the reactive materials do not degrade and remain unreacted and constant discharge temperature, among others.

Even though an analysis of possible thermochemical storage materials was given already in the 1970s [16], only recently thermochemical reactions regained an important role in the development of high temperature heat storage. Even so the development of those storage systems is still at an early stage [17]. Several materials have been tested, e.g. sulfates [18], calcium carbonate [19-21] or hydroxide [22, 23], ammonia [13], manganese carbonate or hydroxide [14] etc. However among these systems, ammonia has the inherent disadvantage of requiring high pressures, whereas dissociation reactions of carbonates or hydroxides produce CO₂ or H₂O respectively, which have to be separated/evaporated. In this respect, among the possible reversible gas-solid reactions, the utilization of a pair of redox reactions involving multivalent solid oxides like in (1), is most attractive for large-scale deployment, since air is used as both the heat transfer fluid and the reactant and therefore it can come to direct contact with the storage material with the two reactions producing simply oxygen-lean or oxygen-rich air. Cobalt oxide is considered among

the most attractive oxides for this application since its endothermic reduction takes place in air at about 900°C – a temperature that can be achieved within the new generation of volumetric-receivers-based solar tower power plants – under atmospheric pressure and its energy density is 844 kJ/kg (among the highest for such oxide systems). Preliminary material tests showed good reaction kinetics and long-term material stability [24, 25]. Nevertheless, further research is needed on this material: in the one hand on tailoring its heat storage/release capability to the operating conditions of a real solar tower plant and on the other hand in conjunction with the development of effective reactor/heat exchanger devices. In this work, two such reactor concepts are concerned: structured ceramic reactors/heat exchangers with enhanced transport, thermal and heat recovery properties based on honeycombs coated with the redox oxide powder and powder-fed, solar-heated rotary kiln reactors.

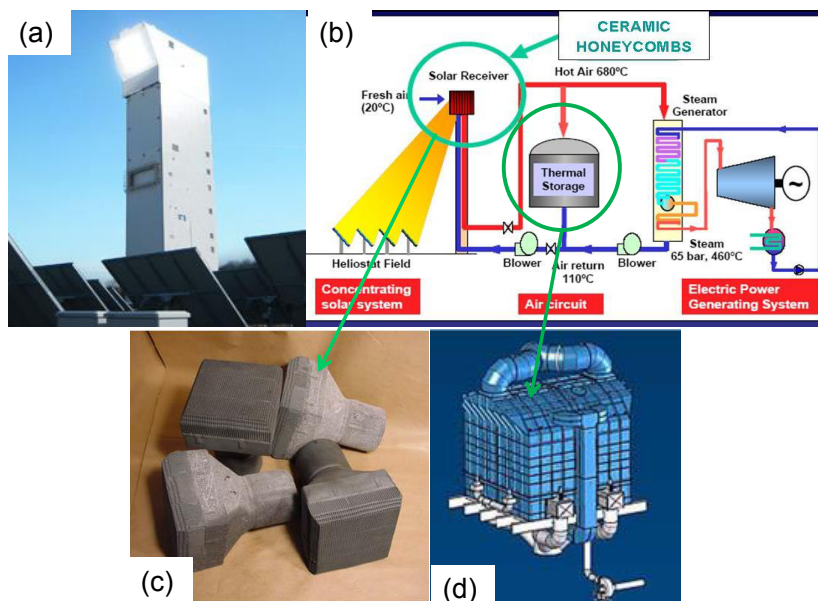

Fig. 1: (a) The Solar Tower power plant of Jülich (STJ); (b) schematic of operating principle, plant layout and process parameters [10]; (c) silicon carbide honeycombs used in the solar receiver sub-system for the absorbance of concentrated solar irradiation and heating of ambient air; (d) storage sub-system housing [6].

2. Cyclic reduction/oxidation of redox powders

The first set of experiments involved Thermo-Gravimetric Analysis (TGA) studies on redox powders to identify the optimal operating conditions for reproducible cyclic reduction-oxidation behavior. The testing procedure involved cyclic heating-up of Co_3O_4 as well as of Co_3O_4 -based binary powder metal oxide compositions under air, to temperatures higher than the redox one and cooling them down to temperatures lower than that. The upper/lower temperature limits, the dwell times in each one and the heating/cooling rates were varied; however, for reasons of brevity only representative results from these studies are shown here. The last step of the cycle (i.e. the final cool-down from the upper temperature limit to ambient temperature) was always performed under Argon gas so that the phase composition of the reduced state of the material could be identified by X-Ray Diffraction (XRD) analysis.

The results of a two-cycles experiment performed with Co_3O_4 powder, between upper and lower temperature limits of 985 and 785°C respectively with a ramp rate of $5^{\circ}\text{C}/\text{min}$, are shown in Fig. 2a. It is obvious that the material exhibits an almost fully reproducible cyclic reduction-oxidation behavior. During the first heat-up when a temperature of approximately 900°C is reached, an abrupt reduction of weight takes place. A weight calculation shows that the material is fully reduced during this step, since the theoretical maximum weight loss expected from the stoichiometry of reaction (1) is 6.64% . This is further corroborated from the respective XRD spectra of the

initial powder and of that after reduction compared in Fig. 2b; the latter consists entirely of single-phase CoO. A slight “hysteresis” is observed during cool-down from the maximum temperature: the powder starts to re-gain weight (oxidize) at 885°C. During the time required to reach the lower limit temperature and return to the redox one with the particular ramp rate, the material is capable of re-gaining its initial weight (i.e. to undergo full re-oxidation). This behavior is fully reproducible during the second cycle.

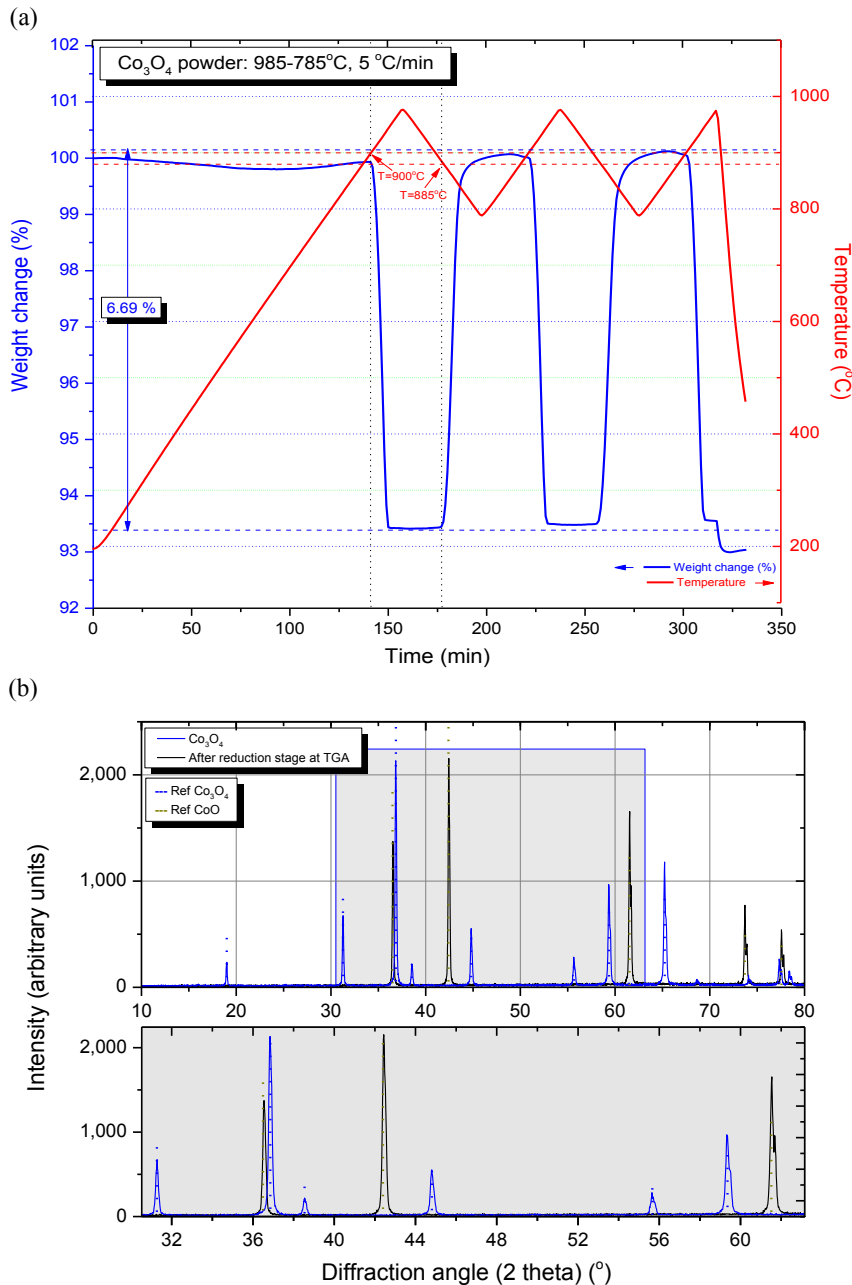

Fig. 2: (a) Weight variation as a function of temperature of Co_3O_4 powder in the TGA; (b) phase comparison between the oxidized (initial) and the reduced (final) state of the powder.

3. Structured TCS heat exchanger/reactor concepts

3.1. The coated honeycomb TCS heat exchanger/reactor concept

Ceramic honeycombs capable of absorbing solar radiation (like those shown in Fig. 1c) even though extensively explored and established as volumetric receivers of solar irradiation, were not explored as the building blocks of structured solar reactors, until recently (2005) when the HYDROSOL research group has introduced the concept of monolithic honeycomb solar reactors consisting of SiC honeycombs coated with redox pair mixed-iron-oxides for performing thermochemical cycles for the production of hydrogen from the splitting of steam using solar energy [26-29], currently scaled-up and demonstrated to the 100-kW level [29].

Stemming from this established technology, the present work sets forth the idea of coating the ceramic honeycombs employed in the storage module of STJ with redox materials like Co_3O_4 , being capable for reduction/oxidation within the operating temperature range of the plant. In this respect, during on-sun operation, in addition to the (sensible) heating of the (chemically inert) honeycombs, solar heat will be stored simultaneously thermochemically via the endothermic reduction of the Co_3O_4 coating to CoO. Similarly, during off-sun operation the colder air to be introduced to the storage unit will be heated not only via the sensible heat of the already hotter honeycomb supports but via the additional heat generated through the exothermic oxidation of the CoO coating to Co_3O_4 . In both cases, the storage volumetric density can be substantially increased. In this respect, the storage module will become from a simply “sensible heat storage” to a hybrid “sensible-thermochemical storage” one.

3.2. Cyclic reduction/oxidation of coated honeycombs

As a first step towards investigations in this direction, since, in addition to powder samples the particular TGA sample holder can also accommodate small structured specimens, mini-honeycombs from cordierite were prepared by sectioning from larger ones (Fig. 3a), coated with Co_3O_4 in various loading percentages (Fig. 3b) and then tested in the TGA (Fig. 3c) in a procedure similar to that used for the “plain” powders (Fig. 3d). The coating took place by impregnating the honeycombs into properly prepared Co_3O_4 powder slurries and subsequent drying and calcination of the coated honeycombs at a temperature of 800°C .

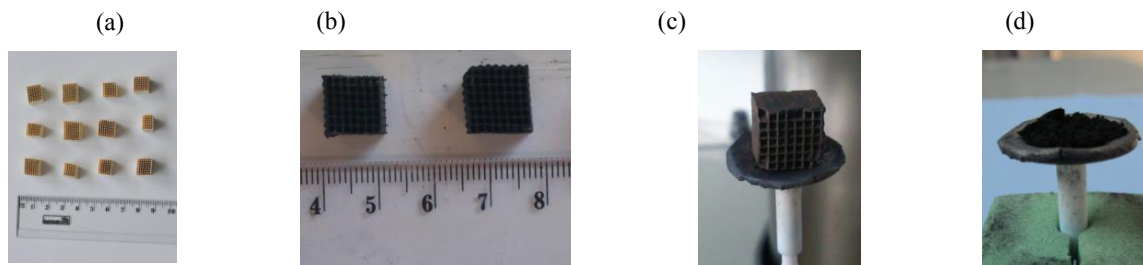

Fig. 3: (a) Non-loaded cordierite mini-honeycombs; (b) Co_3O_4 -loaded mini-honeycombs; (c) Co_3O_4 -loaded mini-honeycomb and (d) Co_3O_4 powder, respectively, on the TGA holder before an experiment.

Fig. 4a shows the results of a thirty-cycles experiment performed with a honeycomb loaded with the same Co_3O_4 powder (loading percentage 28 wt%) under the same testing conditions with those for the powder shown in Fig. 2a. It is obvious that the coated honeycomb is capable of long-term cyclic oxidation/reduction performance without a significant activity loss. The first two cycles are shown in Fig. 4b compared to the performance of the “plain” powder. In addition, the weight variation for the experiment with the loaded honeycomb, calculated on the basis of only the weight of the powder loaded (and not per the weight of the whole honeycomb) is plotted on the same graph. It can be concluded that, under these conditions, there is practically no difference in behavior between the powder loaded on the honeycomb and the “plain” powder: they both exhibit the same weight loss/gain within the same temperature limits. In other words, at this particular loading percentage, practically all the quantity of powder on the honeycomb is exploited for cyclic reduction/oxidation.

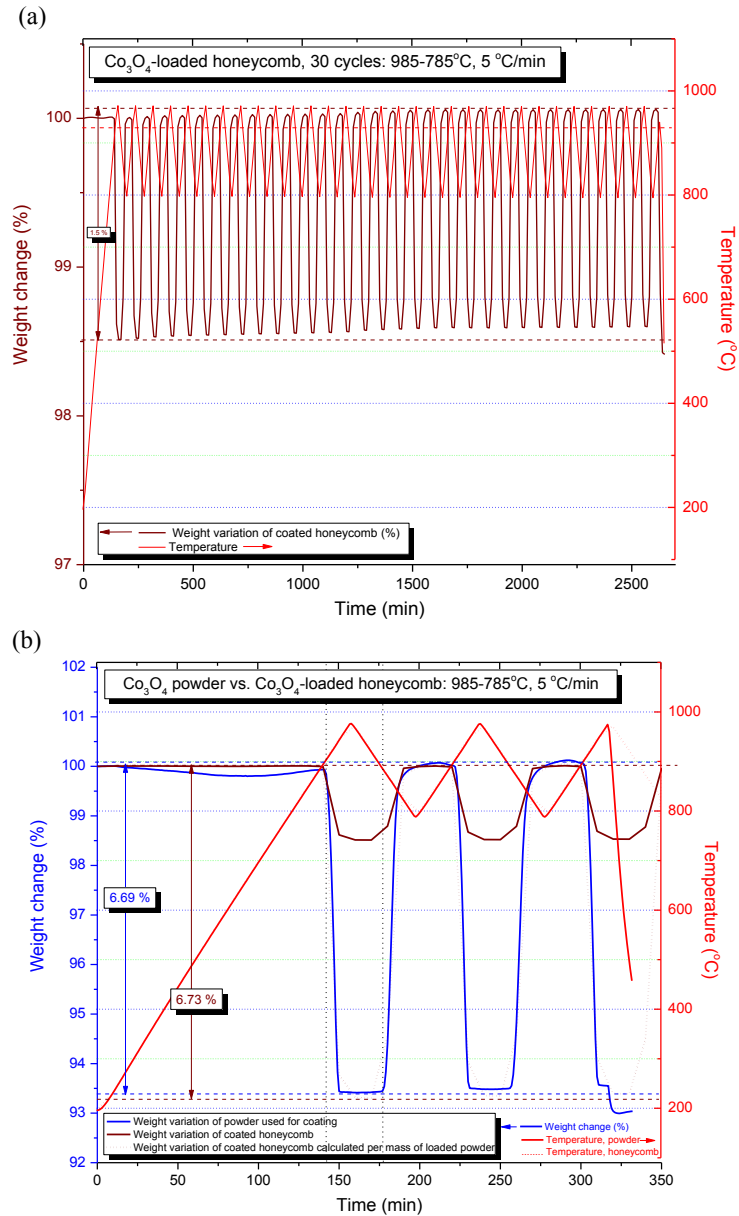

Fig. 4: (a) Thirty-cycles reduction/oxidation TGA test of mini-honeycomb loaded with 28 wt% Co₃O₄ powder; (b) Comparison of weight variation as a function of temperature in the TGA between “plain” Co₃O₄ powder and Co₃O₄-loaded honeycomb (first two redox cycles).

4. Non-structured TCS heat exchanger/reactor concepts

4.1. The rotary kiln TCS heat exchanger/reactor concept

Thermochemical heat storage using a storage medium in the form of powder can be performed via several reactor concepts for example packed beds, fluidized beds or rotary kilns. Several of these concepts have already been tested in lab-scale. The simplest reactor concept is a packed bed reactor within which charging and discharging phases can

be performed through hot/cold air. This reactor concept is relatively easy to be built and operate, but has some drawbacks. One of these is the high energy losses due to the pressure drop inside the bed when scaling up the reactor. Another drawback is that, the high reaction temperatures required to be achieved during the charging phase necessitate the use of even higher heating fluid temperatures and thus higher temperatures on the receiver.

This second drawback could be overcome by heating the reactive particles directly, through concentrated solar radiation, by introducing the particles directly on the receiver, through a reactor/receiver configuration. A promising option for this concept is a rotary kiln reactor configuration. Several advantages can be attributed to this design. For example, it is well known that cavity shape allows obtaining uniform temperature on the internal wall, and reduce radiation heat losses. Furthermore the particle movement intensifies the heat transfer not only between the particles themselves but also between the particles and the wall.

The feasibility of the concept of thermochemical heat storage through cobalt oxide powder inside a rotary kiln was successfully demonstrated in a previous study [15] where a solar driven rotary kiln was used in batch mode to drive in a cyclic way reaction (1). The chemical conversion achieved was higher than 50%. However, the energy efficiency calculated (as the ratio of the energy absorbed by the reaction to the incident solar radiation) resulted limited, due to the reactor configuration: the mass of the reactor was much higher than the mass of reactive particles. Due to this high thermal inertia, most of the incident energy was used to heat up the reactor and only a small part was used for the reaction itself. For this reason, a new optimized rotary kiln (Fig. 5a) is designed, working in continuous mode. The continuous flowing of the particles allows heating up the reactor only once, at the beginning of the experiment. The incident energy is used only for the chemical reaction (reduction of material) and to keep the reactor in steady state, by compensating for the heat losses. The second part of the cycle (material oxidation) takes place on a separate reactor, called oxidation tank (OT) as the one schematically shown in Fig. 5b. The particle extracted from the rotary kiln will be conveyed to the OT under nitrogen atmosphere. The OT will store thus the energy, until the heat is requested. The discharge of the storage will be done through a flow of cold air (from the bottom of the reactor), which will pass through the reactive material, absorbing the sensible and chemical heat released by the particles. The design of the OT is developed at present in a parallel work.

4.2. Optimized rotary kiln

The reactor schematic is shown in Fig. 5a. The particles enter through the rear part of the reactor (right side of Fig. 5a), flow through along the kiln's length and extracted continuously through a pipe situated on the lower front side (on the left of Fig. 5a). On the cylindrical interior wall, four straight flights are welded to better control particles movement and improve their mixing. The incident energy enters through a window situated on a high temperature steel flange. The gas (air) enters both through the front and the rear side. In the front, the inlet holes are situated around the window, allowing also its cooling down; on the rear side air enters in the same direction with the powder.

Some key points are addressed in this study, in order to adapt the reactor to the specific process's objectives. A numerical model, described in a previous paper [30], was developed and used in order to analyze different aspects of the reactor geometry and design.

The first point analyzed regarded the inlet flow on the window side. One of the key points is in fact to prevent the particles to stick on the window, decreasing thus its transparency. This leads in the one hand to a dangerous increase of the window temperature which may cause its breakage and in the other hand to a decrease of the incident solar radiation entering in the reactor. The most common way to prevent particle deposition is to flush the window with a gas. As suggested [31], the creation of a cyclone in front of the window can have a beneficial effect. Several directions of the inlet gas were studied by varying the radial, tangential and axial components of the inlet gas velocity. The configuration which at best prevents the gas coming from the back of the reactor (thus rich in particles) to get in contact with the window surface is the inlet gas flow parallel to the window, in radial direction pointing the center of the window. Adding a component of the velocity perpendicular to the window leads to a decrease of the gas velocity in the window's center which could cause a deposition or an overheating in this point.

The optimal aperture of the reactor (of 6.5cm radius) was calculated as suggested in [32], by considering an operating temperature of 950°C and a Gaussian distribution of the incident radiation F (W/m²) measured at the solar simulator of DLR, Cologne, at a distance of 2 cm in front of the focal surface (position where the reactor aperture will be placed):

$$F = 2.512 \cdot 10^6 \cdot \exp(-r^2/1.568 \cdot 10^{-3}) \quad (2)$$

The reactor length was chosen through the following rationale. In the one hand a long reactor allows to have a larger variation range for the particles' residence time; in the other hand this leads to a high reactor surface (higher heat losses by conduction), to an increase of the reactor's thermal inertia and thus of the heating time and to a decrease of temperature uniformity along the wall.

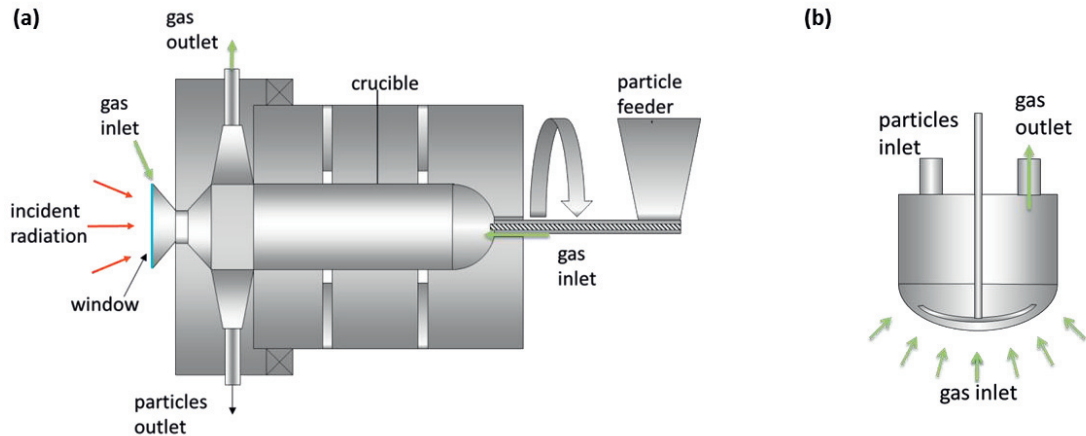

Fig. 5: Scheme of: (a) continuous working rotary kiln for powder material; (b) first draft of the oxidation tank.

Simulations were performed with different reactor lengths by imposing 8 kW of incident radiation. The temperature distribution at the gas-solid interface when steady state was reached is shown in Fig. 6a. It can be noticed that for a short reactor the temperature obtained is higher and more uniform than that for a longer reactor. The dynamic behavior of the reactors when changing the length, can also be compared. It was calculated that the time needed to reach 950°C in the middle of the cavity varied between 2h for the shortest cavity ($L=0.56\text{m}$) to more than 8h for the longest one ($L=0.84\text{m}$). These results show the benefits of having a short cavity. In the other hand, a long cavity allows for increasing the residence time of the reactive material inside the reactor and also ensures a lower temperature on the bottom of the cavity, where the motor of the screw feeder is placed. Calculations showed that a cavity length of 0.7m leads to a residence time of about 20min (time needed for the completion of the reaction following [15]), if the rotational speed is 2rpm and the inclination is 2°. A smaller inclination should be difficult to control due to positioning errors. A lower rotational speed cannot guarantee sufficient mixing between the particles. For this reason a cavity of 0.7m was chosen.

Simulations were also performed with different reactor radii (Fig. 6b). The radius of the cavity was chosen as 0.12m based on the following arguments. In the one hand, a high cavity radius leads to higher apparent emissivity of the reactor. This change is negligible if, as in our case, the material emissivity is higher than 0.5, while it becomes more important if the particles or the wall have a low emissivity (for a change on the apparent emissivity higher than 10% the material emissivity must be lower than 0.2). A higher radius also results in a more uniform temperature inside the reactor (Fig. 6b). Moreover a high cavity radius leads also to the decrease of the thickness of the particle bed (which enhances the heat transfer and the contact between particles and gas) is not important in our case, due to the presence of the flights inside the reactor. Last, a higher radius allows for a higher quantity of material inside the reactor. In the other hand, a higher radius increases the conduction heat losses, as the surface becomes higher. Moreover the quantity of insulation increases for the same insulation thickness. Finally, the residence time of the particles decreases with increasing radius.

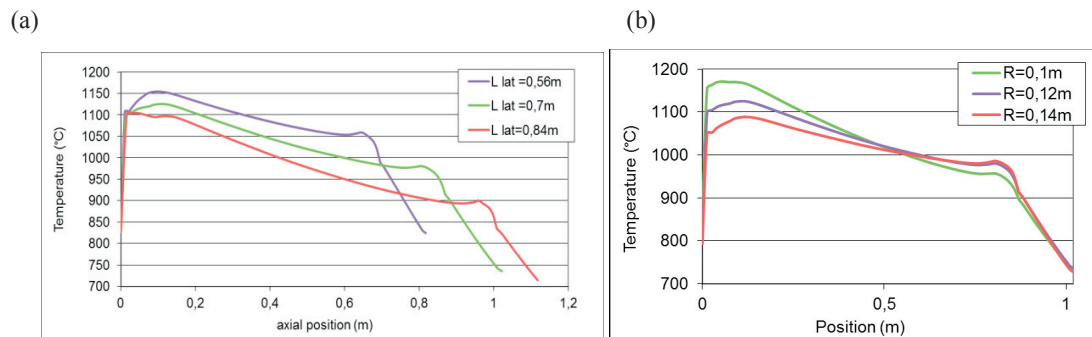

Fig. 6: Temperature distribution on the cavity internal wall: (a) for 3 different reactor lengths; (b) for 3 different reactor radii. $I_0 = 8$ kW and aperture radius 0.65m.

Expected performance is that the reactor will be able to store about 4kW power for an operation time of 1.5h. This, considering a chemical conversion of 50% [15] will result in about 50kg Co_3O_4 converted into CoO , corresponding to 21.6 MJ.

5. Conclusions and future development

Thermochemical solar heat storage with redox oxides is a promising route for increasing the storage density of Solar Thermal Power Plants. However, a necessary condition for its large-scale implementation is the development of efficient, integrated thermochemical reactors/heat exchangers, suitably incorporated within the plants' infrastructure. One option is redox-oxide-powders-fed rotary kiln receiver/reactors that can be directly solar-irradiated. Another option is redox-powder-coated honeycomb reactors. Direct solar heating of the latter via implementation of integrated receiver/reactors is rather complicated to be realized in large-scale due to limited available irradiated surface and material conductivity. For this reason the heating up of such reactors "indirectly" by using hot air produced in a separate solar receiver is considered the best option. This can be realized by placing the reactor inside an insulating housing where air passes through, transferring its heat to the solid material.

Current work is focused in both directions. In the one hand the designed rotary kiln reactor will be completed and tested in a solar campaign. Another testing campaign is foreseen for a small-scale coated honeycomb reactor that will be manufactured. Calculations are under way for both reactors to define their characteristics, as for example reactor dimensions, supplementary devices required and parasitic losses (e.g. due to rotation in the former case or pumping power to overcome the pressure drop in the latter case). Design issues concern the maximum amount of redox powder that can be incorporated and exploited efficiently in each reactor concept and effective control of the charging/discharging phases to maximize off-sun operation potential.

Acknowledgements

The authors would like to thank the European Commission for partial funding of this work within the Collaborative Project "Thermal energy storage for CSP plants: Redox Materials-based Structured Reactors/Heat Exchangers for Thermo-Chemical Heat Storage Systems in Concentrated Solar Power Plants (RESTRUCTURE) – contract n° 283015" under the Energy 2011.2.5.1 Call.

References

- [1] Pacheco, J. E.; Bradshaw, R. W.; Dawson, D. B.; De la Rosa, W.; Gilbert, R.; Goods, S. H.; Hale, M. J.; Jacobs, P.; Jones, S. A.; Kolb, G. J.; Prairie, M. R.; Reilly, H. E.; Showalter, S. K.; Vant-Hull, L. L. *Final Test and Evaluation Results from the Solar Two Project*; Solar Thermal Technology, Sandia National Laboratories: P.O. Box 5800, Albuquerque, NM 87185-0703, 2002.
- [2] Steinmann, W.-D.; Eck, M., Buffer storage for direct steam generation. *Solar Energy* **2006**, *80*, (10), 1277-1282.
- [3] Laing, D.; Steinmann, W.-D.; Tamme, R.; Richter, C., Solid media thermal storage for parabolic trough power plants. *Solar Energy* **2006**, *80*,

- (10), 1283-1289.
- [4] Zanganeh, G.; Pedretti, A.; Zavattoni, S.; Barbato, M.; Steinfeld, A., Packed-bed thermal storage for concentrated solar power – Pilot-scale demonstration and industrial-scale design. *Solar Energy* **2012**, *86*, (10), 3084-3098.
- [5] Py, X.; Calvet, N.; Olives, R.; Meffre, A.; Echegut, P.; Bessada, C.; Veron, E.; Ory, S., Recycled Material for Sensible Heat Based Thermal Energy Storage to be Used in Concentrated Solar Thermal Power Plants. *Journal of Solar Energy Engineering* **2011**, *133*, (031008), 1-8.
- [6] Zunft, S.; Hänel, M.; Krüger, M.; Dreißigacker, V.; Göhring, F.; Wahl, E., Jülich solar power tower - experimental evaluation of the storage subsystem and performance calculations. In *16th Solar PACES International Symposium*, Perpignan, France, 2010.
- [7] Fend, T.; Hoffschmidt, B.; Pitz-Paal, R.; Reuter, O.; Rietbrock, P., Porous Materials as Open Volumetric Solar Receivers: Experimental Determination of Thermophysical and Heat Transfer Properties. *Energy* **2004**, *29*, (5-6), 823 - 833.
- [8] Hoffschmidt, B.; Fernández, V.; Pitz-Paal, R.; Romero, M.; Stobbe, P.; Téllez, F. In *The development strategy of the HiTREC volumetric receiver technology – up-scaling from 200kWth via 3MWth up to 10MWth*, Proceedings of 11th SolarPACES International Symposium on Concentrated Solar Power and Chemical Energy Technologies, Zürich, Switzerland, September 2002, 2002; Zürich, Switzerland, 2002.
- [9] Agrafiotis, C. C.; Mavroidis, I.; Konstandopoulos, A. G.; Hoffschmidt, B.; Stobbe, P.; Romero, M.; ValerioFernandez, Q., Evaluation of porous silicon carbide monolithic honeycombs as volumetric receivers/collectors of concentrated solar radiation. *Solar Energy Materials and Solar Cells* **2007**, *91*, (6), 474-488.
- [10] Zunft, S.; Hänel, M.; Krüger, M.; Dreißigacker, V., High-temperature heat storage for air-cooled solar central receiver plants: a design study. In *Solar PACES International Symposium*, Berlin, Germany, 2009.
- [11] Laing, D.; Eck, M.; Hempel, M.; Steinmann, W.-D.; Meyer-Grünefeldt, M.; Eickhoff, M., Analysis of Operation Test Results of a High Temperature Phase Change Storage for Parabolic Trough Power Plants With Direct Steam Generation. In *ASME 2012 6th International Conference on Energy Sustainability ES2012*, San Diego, CA, USA, 2012; Vol. ES2012.
- [12] Tamme, R.; Laing, D.; Steinmann, W.-D., Advanced Thermal Energy Storage Technology for Parabolic Trough. *Journal of Solar Energy Engineering* **2004**, *126*, (2), 794-800.
- [13] Lovegrove, K.; Luzzi, A.; Soldiani, I.; Kreetz, H., Developing ammonia based thermochemical energy storage for dish power plants. *Solar Energy* **2004**, *76*, (1-3), 331-337.
- [14] Kato Y., S. T., Ryu J., Packed bed reactor demonstration of magnesium oxide/water chemical heat pump. In *ecostock 2006*, Pomona NJ, USA, 2006.
- [15] Neises, M.; Tescari, S.; de Oliveira, L.; Roeb, M.; Sattler, C.; Wong, B., Solar-heated rotary kiln for thermochemical energy storage. *Solar Energy* **2012**, *86*, (10), 3040-3048.
- [16] Wentworth, W. E.; Chen, E., Simple thermal decomposition reactions for storage of solar thermal energy. *Solar Energy* **1976**, *18*, (3), 205-214.
- [17] Gil, A.; Medrano, M.; Martorell, I.; Lázaro, A.; Dolado, P.; Zalba, B.; Cabeza, L. F., State of the art on high temperature thermal energy storage for power generation. Part I—Concepts, materials and modellization. *Renewable and Sustainable Energy Reviews* **2010**, *14*, (1), 31-55.
- [18] Tmar, M.; Bernard, C.; Ducarroir, M., Local storage of solar energy by reversible reactions with sulfates. *Solar Energy* **1981**, *26*, (6), 529-536.
- [19] Flamant, G.; Hernandez, D.; Bonet, C.; Traverse, J.-P., Experimental aspects of the thermochemical conversion of solar energy; Decarbonation of CaCO₃. *Solar Energy* **1980**, *24*, (4), 385-395.
- [20] Kubota, M.; Kyaw, K.; Watanabe, F.; Matsuda, H.; Hasatani, M., Study of Decarbonation of CaCO₃ for High Temperature Thermal Energy Storage. *Journal of Chemical Engineering of Japan* **2000**, *33*, (5), 797-800.
- [21] Edwards, S. E. B.; Materić, V., Calcium looping in solar power generation plants. *Solar Energy* **2012**, *86*, (9), 2494-2503.
- [22] Murthy, M. S.; Raghavendrachar, P.; Sriram, S. V., Thermal decomposition of doped calcium hydroxide for chemical energy storage. *Solar Energy* **1986**, *36*, (1), 53-62.
- [23] Schaube, F.; Wörner, A.; Müller-Steinhagen, H. In *High temperature heat storage using gas-solid reactions*, EFFSTOCK 11th International Conference on Energy Storage, Stockholm, Schweden, June 14 - 17, 2009; Stockholm, Schweden, 2009.
- [24] Wong, B.; Brown, L.; Schaube, F.; Tamme, R.; Sattler, C. In *Oxide based thermochemical heat storage*, 16th Solar PACES International Symposium, Perpignan, France, 2010; Perpignan, France, 2010.
- [25] Hutchings, K. N.; Wilson, M.; Larsen, P. A.; Cutler, R. A., Kinetic and thermodynamic considerations for oxygen absorption/desorption using cobalt oxide. *Solid State Ionics* **2006**, *177*, (1-2), 45-51.
- [26] Agrafiotis, C.; Roeb, M.; Konstandopoulos, A. G.; Nalbandian, L.; Zaspalis, V. T.; Sattler, C.; Stobbe, P.; Steele, A. M., Solar water splitting for hydrogen production with monolithic reactors. *Solar Energy* **2005**, *79*, (4), 409-421.
- [27] Roeb, M.; Sattler, C.; Klüser, R.; Monnerie, N.; Oliveria, L. d.; Konstandopoulos, A. G.; Agrafiotis, C.; Zaspalis, V. T.; Nalbandian, L.; Steele, A.; Stobbe, P., Solar Hydrogen Production by a Two-Step Cycle Based on Mixed Iron Oxides. *J. Solar Energy Eng.* **2006**, *128*, 125 - 133.
- [28] Agrafiotis, C. C.; Pagkoura, C.; Lorentzou, S.; Kostoglou, M.; Konstandopoulos, A. G., Hydrogen production in solar reactors. *Catalysis Today* **2007**, *127*, 265 - 277.
- [29] Roeb, M.; Säck, J. P.; Rietbrock, P.; Prah, C.; Schreiber, H.; Neises, M.; de Oliveira, L.; Graf, D.; Ebert, M.; Reinalter, W.; Meyer-Grünefeldt, M.; Sattler, C.; Lopez, A.; Vidal, A.; Elsberg, A.; Stobbe, P.; Jones, D.; Steele, A.; Lorentzou, S.; Pagkoura, C.; Zygiogianni, A.; Agrafiotis, C.; Konstandopoulos, A. G., Test operation of a 100 kW pilot plant for solar hydrogen production from water on a solar tower. *Solar Energy* **2011**, *85*, (4), 634-644.
- [30] Tescari, S.; Neises, M.; Oliveira, L. d.; Roeb, M.; Sattler, C.; Neveu, P., Thermal model for the optimization of a solar rotary kiln to be used as high temperature thermochemical reactor. *Solar Energy* **2013**, *paper accepted on June 2013*.
- [31] Jaya Krishna, D.; Ozalp, N., Numerical investigation of particle deposition inside aero-shielded solar cyclone reactor: A promising solution for reactor clogging. *International Journal of Heat and Fluid Flow* **2013**, *40*, (0), 198-209.
- [32] Steinfeld, A.; Schubnell, M., Optimum aperture size and operating temperature of a solar cavity-receiver. *Solar Energy* **1993**, *50*, (1), 19-25.