

EUROPEAN AIRPORT MOVEMENT MANAGEMENT BY A-SMGCS

Contract No. TREN/04/FP6AE/SI2.374991/503192

Operational Requirements Document (ORD-Update)

EEC

Document No: D1.3.5u
Version No. 1.0
Classification: Public
Number of pages: 114

Project Funded by
European Commission, DG TREN
The Sixth Framework Programme
Strengthening the competitiveness
Contract No. TREN/04/FP6AE/SI2.374991/503192

Project Manager
M. Röder
Deutsches Zentrum für Luft und Raumfahrt
Lilienthalplatz 7, D-38108 Braunschweig, Germany
Phone: +49 (0) 531 295 3026, Fax: +49 (0) 531 295 2180
email: fp6-emma@dlr.de
Web page: <http://www.dlr.de/emma>

© 2006, - All rights reserved - EMMA Project Partners

The reproduction, distribution and utilization of this document as well as the communication of its contents to other without explicit authorization is prohibited. This document and the information contained herein is the property of Deutsches Zentrum für Luft- und Raumfahrt and the EMMA project partners. Offenders will be held liable for the payment of damages. All rights reserved in the event of the grant of a patent, utility model or design.

The results and findings described in this document have been elaborated under a contract awarded by the European Commission.

Distribution List

Member Type	No.	Name	POC	Distributed
Web		Internet	http://www.dlr.de/emma	X
		Intranet	https://extsites.dlr.de/fl/emma	X
Contractor	1	DLR	Joern Jakobi	X
	2	AENA	Francisco Rodríguez Angelina	X
	3	AI	Marianne Moller	X
	4	SELEX	Giuliano D'Auria	X
	5	ANS_CR	Miroslav Tykal	X
	6	BAES	Stephen Broatch	X
	7	STAR	Max Koerte	X
	8	DSNA	Nicolas Marcou	X
	9	ENAV	Antonio Nuzzo	X
	10	NLR	Frans van Schaik	X
	11	PAS	Alan Gilbert	X
	12	TATM	Stephane Paul	X
	13	THAV	Alain Tabard	X
	14			
	15	AUEB	Konstantinos G.Zografos	X
	16	CSL	Libor Kurzweil	X
	17	DAV	Rolf Schroeder	X
	18	DFS	Klaus-Ruediger Täglic	X
	19	EEC	Stephane Dubuisson	X
	20	ERA	Jan Hrabanek	X
	21	ETG	Thomas Wittig	X
	22	MD	Phil Mccarthy	X
	23	SICTA	Claudio Vaccaro	X
	24	TUD	Christoph Vernaleken	X
Sub-Contractor		CSA	Karel Muendel	X
Customer		EC	Morten Jensen	X
Additional		EUROCONTROL	Paul Adamson	X

Document Control Sheet

SP1 Project Manager	Jörn Jakobi	
Responsible Author	Olivier Delain	EEC
Additional Authors	Miroslav Tykal	ANS_CR
	Francisco Rodriguez Angelina	AENA
	Mario Parra Martínez	AENA
	Raimund Weidemann	DFS
	Joern Jakobi	DLR
	Pascale Henry-Ducos	DSNA
	Nicolas Marcou	DSNA
	Olivier Delain	EEC
	Maria Grazia Bechere	ENAV
	Max Koerte	STAR
Reviewer	Stephane Paul	TATM
	Jean-Pierre Lesueur	EUROCONTROL
Subject / Title of Document:	Operational Requirements Document (ORD-Update)	
Related Task(s):	WP1.3	
Deliverable No.	D1.3.5	
Save Date of File:	2006-04-25	
Document Version:	1.0	
Reference / File Name	D135u_ORD-update_V1.0.doc	
Number of Pages	114	
Dissemination Level	Public	
Target Date	2006-03-31	

Change Control List (Change Log)

Date	Issue	Changed Items/Chapters	Comment
2005-03-31	0.01		Initial draft
2005-07-29	0.02	All chapters	Update following ORD workshop (June)
2005-09-14	0.03	All chapters	Modifications following comments and contributions
2005-10-07	0.04	Sections 8.2.5, 8.3.4, chapter 10	Modifications following comments and contributions.
2005-11-25	0.05		Modifications following comments and contributions.
2005-12-23	0.06		Modifications following comments and contributions.
2006-02-02	0.07		Modifications following comments and contributions
2006-02-02	0.08	Formal Review	DLR
2006-04-25	1.0	Review of the European Commission	European Commission's document's approval, Document in the web: www.dlr.de/emma

Table of Contents

Distribution List	2
Document Control Sheet	3
Change Control List (Change Log)	3
Table of Contents	4
1 Introduction	7
1.1 Scope of the Document	7
1.2 Guidance for Usage	7
1.3 Structure of this Document	8
1.4 Consistency of documents	9
1.5 Linked EMMA Documents	10
1.6 Acronyms	10
1.7 Explanation of terms	12
1.8 EMMA ORD Partners' Responsibilities	15
2 Operational Concept	17
2.1 Operational objectives	17
2.2 EMMA Services	17
3 Regulatory Aspects	19
3.1 Air Traffic Service Provider	19
3.2 Aircraft Operator	20
3.2.1 Basic Framework	20
3.2.2 Specific Framework for Commercial Operators	20
4 Transponder Operating Procedures	21
4.1 Departure	21
4.1.1 At the gate / stand	21
4.1.2 On requesting push back / taxi (whichever is earlier)	21
4.1.3 When Lining Up	21
4.2 Arrival	21
4.2.1 When Still on the Runway	21
4.2.2 After Vacating the Runway	21
4.2.3 Fully Parked on Stand	22
4.3 Miscellaneous	22
4.4 ADS-B issues	22
5 Visibility Transitions	24
5.1 Definition of values for A-SMGCS visibility threshold	24
5.2 ICAO A-SMGCS Manual Definitions	24
5.3 Air Traffic Control operational concerns	24
5.3.1 Visibility Condition 1	24
5.3.2 Visibility Condition 2	24
5.3.3 Visibility Condition 3	25
5.3.4 Application to Movements on the Surface	25
5.3.5 Existing Transition Values	26
5.3.6 Consideration on Visibility Condition 3-4 Transition	27
5.4 Summary	27
6 A-SMGCS phraseology	28
6.1 Procedure Changes	28
6.2 The Squawk problem	28
7 Operating Procedures for Air Traffic Control	30
7.1 Introduction	30
7.2 Identification Procedures	30
7.2.1 Standard A-SMGCS identification procedures	31
7.2.2 Contingency A-SMGCS identification procedures	32

7.2.3	Lost identification.....	32
7.3	Standard ATC Procedures Description.....	33
7.3.1	ATC/Start-Up Clearance	33
7.3.2	Push-Back Clearance.....	34
7.3.3	Taxi Clearance.....	36
7.3.4	Control of Taxiway Intersection.....	37
7.3.5	Handover between Approach, Departure, Aerodrome, Ground, and Apron Control.....	39
7.3.6	Taxiing on the Runway	41
7.3.7	Line-Up Procedures.....	42
7.3.8	Take-Off Clearances.....	45
7.3.9	Conditional Clearances.....	46
7.3.10	Landing Clearance.....	47
7.3.11	Summary	47
7.4	Control Procedures associated to the Safety Net use.....	48
7.4.1	Existing Safety Net and Warning Tools.....	48
7.4.2	General principles for ground and airborne alerting.....	50
7.4.3	Possible Control Procedures with RIMS (Runway Incursion Monitoring System)	50
7.4.4	RWYs / Protected areas conflict detection rules (C1).....	52
7.4.5	Taxiways conflict detection procedures (C2).....	58
7.4.6	Plan deviation detection (C3).....	64
7.4.7	Support to Ground Clearance and ATCO coordination (C3).....	64
7.4.8	Apron / Stand / Gate conflict detection procedures (C4)	67
7.5	Routing Procedures	69
7.5.1	Manual Routing (R1).....	70
7.5.2	Semi-Automatic Routing (R2)	70
7.5.3	Automatic Routing (R3).....	71
7.5.4	Runway Occupancy Planning (R4)	72
7.5.5	Summary	73
7.6	Guidance Procedures.....	74
7.6.1	Manual Switched Ground Guidance (G1)	74
7.6.2	Automatic Switched Ground Guidance (G2)	74
8	Operating Procedures for Flight Crews.....	75
8.1	Introduction	75
8.2	Basic Procedures	75
8.3	Supplementary Procedures.....	76
8.3.1	Preamble.....	76
8.3.2	Airport Moving Maps (A1)	77
8.3.3	Surface Movement Alerting (A1).....	79
8.3.4	Braking and Steering Cues / Landing Operations (A1).....	80
8.3.5	Ground Traffic Display (A2).....	81
8.3.6	CPDLC Ground Clearances and Taxi Route Uplink (A2)	82
8.3.7	Braking and Steering Cues during Taxi Operations (A2)	83
8.3.8	Ground / Air Database Upload (A2).....	84
8.3.9	HUD Surface Guidance Symbology (A3).....	84
8.3.10	Automated Steering (A4)	85
9	Operating Procedures for Vehicle Drivers	86
9.1	Preamble.....	86
9.2	Airport Moving Map (V1).....	86
9.3	Surface Movement Alerting (V1).....	87
9.4	Ground Traffic Display (V2).....	88
9.5	Vehicle dispatch and guidance by data link (V3).....	88
10	Operational Requirements	90
10.1	Methodology	90

10.1.1 Service Level.....	90
10.1.2 Functional Level.....	90
10.1.3 Architectural Level.....	91
10.2 General Principles	92
10.2.1 Assumptions	92
10.2.2 Requirements.....	92
10.3 Operational Requirements for Surveillance	97
10.4 Operational Requirements for Control	101
10.5 Operational Requirements for Routing.....	106
10.6 Operational Requirements for Guidance	108
11 ANNEX I.....	111
11.1 References	111
11.2 List of Figures.....	111
12 ANNEX II: DOC 4444: A-SMGCS Additional Phraseology	112
13 ANNEX III: Samples of messages (control function).....	113

1 Introduction

The EMMA ORD update document is based on initial version of the EMMA A-SMGCS services as defined in the EMMA OSED Update document. It is to be completed by EMMA partners involved in the production of the ORD.

1.1 Scope of the Document

This document aims at defining the EMMA Operational Requirements (ORD), which captures the operational concepts, procedures and requirements for A-SMGCS implementation.

This document addresses A-SMGCS services. The major headings of this ORD are operating procedures and operational requirements.

Detailed Operational Concepts, A-SMGCS services and environment are described in the EMMA Air-Ground Operational Service and Environmental Description (OSED-update) and will only be outlined in the EMMA ORD.

1.2 Guidance for Usage

The EMMA Operational Requirements document is one of the EMMA Concepts document delivered by the EMMA project.

The EMMA Operational Requirement Document takes into account outputs of international standardisation bodies like ICAO and EUROCAE. EMMA also works hand in hand with the EUROCONTROL A-SMGCS Airport Operations Group who has conducted activities on A-SMGCS services. These outputs have been used to a high degree for the ‘Operational Requirements Document’ (ORD) to describe surveillance and control services on a mature basis. Further developments by EMMA partners have consolidated this basis to address EMMA specific operating procedures regarding ASMGCS services.

Whereas the EMMA Air-Ground Operational Services and Environment Description (OSED-update) document describes the A-SMGCS air-ground environment and its services, the ORD describes operating A-SMGCS procedures and operational requirements. These will be specifically adapted for the three test sites Prague, Toulouse, and Malpensa in three dedicated ‘Test Site Operations Documents’ (EMMA, document D.1.6.1_TSOD).

EMMA is a R&D project; the maturity level of proposals (procedures, possible usage) related to EMMA functions will depend on their current development stage (already implemented, under research, planned short/medium/long term implementation). For instance, it is assumed that the description of surveillance operational requirements and procedures will be more mature compared to proposals linked to HUD surface guidance symbology function. Consequently, this document should be considered as guidelines for use.

Outputs of OSED and ORD documents will be used for preparation of the D.1.4.1 ‘Air-Ground Functional Architecture document’ (AGFA) and the D.1.4.2 ‘Technical Requirements Document’ (TRD), and will be adapted to the test sites in document D.1.6.1 “Test Sites Operations Document” (TSOD).

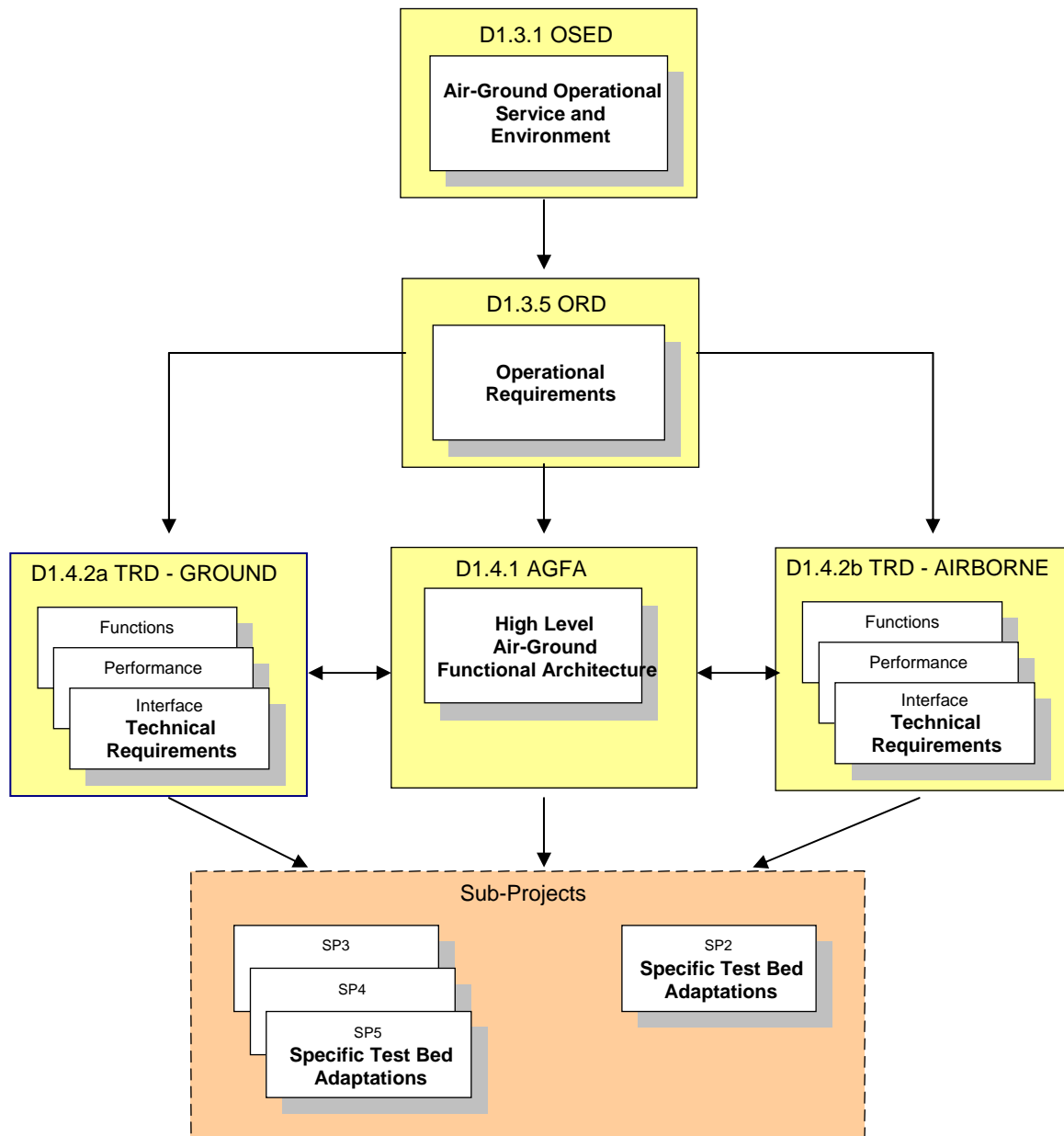

Figure 1-1: D1.3.5u ORD related to other EMMA concept documents

1.3 Structure of this Document

Introduction

Chapter 1 describes the purpose of the document, its structure, reference documents and gives an explanation of terms used throughout the document.

Operational Concept

Chapter 2 introduces the operational concept and principles associated to A-SMGCS Services. Further definition of the concept is provided in the EMMA D.1.3.1u OSED document.

The Regulatory Aspects

Chapter 3 introduces current provisions for governing an aerodrome control service and presents how A-SMGCS procedures could affect these provisions.

Transponder Operating Procedures

Chapter 4 introduces changes to the transponder operating procedures that are requested with the introduction of A-SMGCS.

Visibility Transitions

Chapter 5 describes the visibility conditions defined by ICAO and introduces the ATCO concerns on visibility transitions in the context of utilisation of A-SMGCS.

A-SMGCS Phraseology

Chapter 6 investigates possible changes to the phraseology required by the introduction of A-SMGCS.

Operating Procedures

Chapter 7 investigates the operational procedures for air traffic control that are associated to A-SMGCS services both on ground and air side. Chapter 8 addresses Operating procedures for flight crews while chapter 9 introduces operational procedures for vehicle drivers.

Operational Requirements

Chapter 10 contains the operational requirements associated to A-SMGCS services.

Annexes

Chapter 11 contains annexes of the EMMA Operational Requirement Document.

1.4 Consistency of documents

To provide necessary traceability and consistency between OSED and ORD documents, effort has been placed on bringing ORD document into line with OSED services and steps for implementation.

The following matrix is extracted from the OSED document that shows the logical order of EMMA service steps, organised by user (ATCO (surveillance, control, guidance and routing), flight crew (airborne), and vehicle drivers (vehicle)). References to these logical steps have been embedded throughout this document.

	Expected Steps to each Service			
ATCO Surveillance	S1 id/pos everything manoeuvring	S2 S1 + id/pos a/c + pos vehicles in the movement area		S3 S2 + id/pos vehicles movement area
ATCO Control	C1 Conflict Runway	C2 Conflict Twy	C3 Route Deviation / CPDLC / EFS	C4 Conflict Apron
ATCO Guidance	G1 Manual switched ground guidance		G2 Auto switch	
ATCO Routing		R1 Manual	R2 Semi-auto	R3 Auto (planning)
Flight Crew Onboard Service		A1 AMM	A2 Ground traffic + CPDLC	A3 HUD
Vehicle Drivers Onboard Service		V1 AMM	V2 Ground Traffic	A4 Auto steering
Timeline				
id	Identification			
pos	Position			
veh	Vehicle			
ROP	Runway Occupancy Planning			
AMM	Airport Moving Map			
HUD	Head-Up Display			
S1	Surveillance Service for ATCOs step 1			
C1	Control Service for ATCOs step 1			
G1	Ground guidance means Service for ATCOs step 1			
R1	Routing Service for ATCOs step 1			
A1	Onboard Services for Flight Crews step 1			
V1	Onboard Service for Vehicle Drivers step 1			

Figure 1-2: Logical order for the Implementation of A-SMGCS Service Steps

1.5 Linked EMMA Documents

The following EMMA documents are linked to the EMMA Operational Requirement Document:

- D.1.3.1u Air-Ground Operational Service and Environmental Description (OSED);
- D.1.4.1u Air-Ground Functional Architecture document (AGFA);
- D.1.4.2au and D.1.4.2bu Technical Requirements Documents (TRDa_GND + TRDb_AIR)
- D.1.6.1u Test Site Operations Document for Prague Ruzyně, Toulouse-Blagnac and Milan Malpensa.

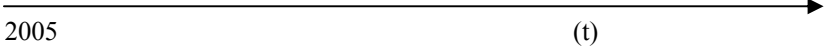
1.6 Acronyms

ACAS	Airborne Collision Avoidance System
ADS	Automatic Dependent Surveillance
ADS-B	Automatic Dependent Surveillance Broadcast

AIP	Aeronautical Information Publication
AMM	Airport Moving Map
ANSP	Air Navigation Service Provider
ANT	Airspace & Navigation Team
APDSG	ATC Procedures Development Sub-Group
APW	Area Proximity Warning
A-SMGCS	Advanced Surface Movement Guidance and Control Systems
ASTERIX	All-purpose Structured Eurocontrol Radar Information Exchanged
ATIS	Automatic Terminal Information Service
ATC	Air Traffic Control
ATCO	ATC Officer
ATM	Air Traffic Management
ATS	Air Traffic Services
BETA	operational Benefit Evaluation by Testing an A-SMGCS
CDM	Collaborative Decision Making
CFIT	Controlled Flight Into Terrain
DGPS	Differential Global Positioning System
EMMA	European airport Movement Management by A-SMGCS
EUROCAE	European Organisation for Civil Aviation Equipment
FDPS	Flight Data Processing System
FMS	Flight Management System
FPL	Filed Flight Plan
GNSS	Global Navigation Satellite System
HMI	Human Machine Interface
ILS	Instrument Landing System
IFPS	Integrated Initial Flight Plan Processing System
IFR	Instrument Flight Rules
ICAO	International Civil Aviation Organisation
JAA	Joint Aviation Authority
JAR	Joint Aviation Requirements
LVP	Low Visibility Procedures
MASPS	Minimum Aircraft System Performance Specification
MET	Meteorological
MLT	Multilateration
MLS	Microwave Landing System
MSAW	Minimum Safe Altitude Warning
NASA	National Aeronautics and Space Administration (USA)
OM	Operations Manual
ORD	Operational Requirements Document
OSD	Operational Services and Environment Description
PSR	Primary Surveillance Radar
RET	Rapid Exit Taxiway
RIMS	Runway Incursion Monitoring System

RPA	Reported Position Accuracy
RPL	Repetitive Flight Plan
RVR	Runway Visual Range
RWY	Runway
SARPS	Standards and Recommended Practices
STCA	Short Time Conflict Alert
SID	Standard Instrument Departure
SMGCS	Surface Movement Guidance and Control Systems
SMR	Surface Movement Radar
SSR	Secondary Surveillance Radar
STBY	Stand By
TA/RA	Traffic Advisory/Resolution Advisory
TCAS	Traffic alert and Collision Avoidance System
TIS-B	Traffic Information System Broadcast
TRD	Technical Requirements Document
TSOD	Test Sites Operations Document
TWY	Taxiway
VFR	Visual Flight Rules
VMC	Visual Meteorological Conditions

1.7 Explanation of terms

This section provides an explanation of the terms required for a correct understanding of the document.

‘ICAO A-SMGCS Manual’ definitions are used as a first option. In general, other definitions are only used where it is necessary to have a more precise technical definition than the ICAO definition. In such cases, it is explained why another definition is preferred to the ICAO definition. When there is no ICAO definition, definition comes from the ‘EUROCAE MASPS for A-SMGCS’, or from Eurocontrol documents. In that case, it is indicated in the definition.

Advanced Surface Movement Guidance and Control Systems (A-SMGCS) [ICAO-A-SMGCS], page (ix)

A system providing routing, guidance and surveillance for the control of aircraft and vehicles in order to maintain the declared surface movement rate under all weather conditions within the aerodrome visibility operational level (AVOL) while maintaining the required level of safety.

Aerodrome visibility operational level (AVOL) [ICAO-A-SMGCS], page (ix)

The minimum visibility at or above which the declared movement rate can be sustained.

Airport authority [ICAO-A-SMGCS], page (ix)

The entity responsible for the operational management of the airport.

Alert [ICAO-A-SMGCS], page (ix)

An indication of an existing or pending situation during aerodrome operations, or an indication of abnormal A-SMGCS operation, that requires attention and/or action.

Alert Situation [EUROCAE-MASPS], page 2

Any situation relating to aerodrome operations, which has been defined as requiring particular

attention or action.

Apron (ICAO SARPS Appendix 14)

[ICAO-A-SMGCS], page (ix)
[EUROCAE-MASPS], page 2

A defined area, on a land aerodrome, intended to accommodate aircraft for purposes of loading or unloading passengers, mail or cargo, fuelling, parking or maintenance.

A-SMGCS capacity

[ICAO-A-SMGCS], page (ix)

The maximum number of simultaneous movements of aircraft and vehicles that the system can safely support within an acceptable delay commensurate with the runway and taxiway capacity at a particular aerodrome

Conflict

[ICAO-A-SMGCS], page (ix)

A situation when there is a possibility of a collision between aircraft and/or vehicles

Cooperative aircraft / vehicle

[EUROCAE-MASPS], page 3¹

Aircraft / vehicle, which is equipped with systems capable of automatically, and continuously providing information including its Identity to the A-SMGCS

Note: as several cooperative surveillance technologies exist, an aircraft or vehicle is cooperative on an aerodrome only if the aircraft or vehicle and the aerodrome are equipped with cooperative surveillance technologies, which are interoperable.

Data Fusion

[EUROCAE-MASPS], page 3

A generic term used to describe the process of combining surveillance information from two or more sensor systems or sources.

False Alert

[EUROCAE-MASPS]

Alert, which does not correspond to an actual alert situation

Note: It is important to understand that it refers only to false alerts and does not address nuisance alerts (i.e. alerts which are correctly generated according to the rule set but are inappropriate to the desired outcome).

Guidance

[EUROCAE-MASPS], page 3

Facilities, information and advice necessary to provide continuous, unambiguous and reliable information to pilots of aircraft and drivers of vehicles to keep their aircraft or vehicles on the surfaces and assigned routes intended for their use.

Identification

[ICAO-A-SMGCS], page (ix)

The correlation of a known aircraft or vehicle call sign with the displayed target of that aircraft or vehicle on the display of the surveillance system.

Identity

[ICAO-4444], page 1-2

A group of letters, figures or a combination thereof which is either identical to, or the coded equivalent of, the aircraft/vehicle call sign to be used in air-ground communications, and which is used to identify the aircraft/vehicle in ground-ground air traffic services communications.

Note: "Aircraft identification" [ICAO-4444] definition has been extended to all aircraft/vehicles.

Incursion

[ICAO-A-SMGCS], page (ix)

Any occurrence at an aerodrome involving the incorrect presence of an aircraft, vehicle or person on the protected areas of a surface designated for the landing, take-off, taxiing and parking of aircraft.

¹ The exact definition is for co-operative target; "target" has been replaced by "aircraft/vehicle"

Intruder

Any aircraft/vehicle, which is detected in a specific airport area into which it is not allowed to enter.

Manoeuvring area

[ICAO-A-SMGCS], page (ix)
[ICAO-Annex14]

That part of an aerodrome to be used for the take-off, landing and taxiing of aircraft, excluding aprons.

Modularity

[EUROCAE-MASPS], page 3

Capability of a system to be enhanced by the addition of one or more modules to improve its technical or functional performance.

Movement area

[ICAO-A-SMGCS], page (ix)
[ICAO-Annex14]
[ICAO-4444]

That part of an aerodrome to be used for the take-off, landing and taxiing of aircraft, consisting of the manoeuvring area and apron(s).

Non-Cooperative aircraft/vehicle

[EUROCAE-MASPS], page 3²

Aircraft/vehicle, which is not equipped with systems capable of automatically, and continuously providing information including its Identity to the A-SMGCS.

Note: In the definition, “target” has been replaced by “aircraft/vehicle.”

Non-Cooperative surveillance

The surveillance of aircraft/vehicles is non-cooperative when a sensor, named non-cooperative surveillance sensor, detects the aircraft/vehicles, without any action on their behalf. This technique allows determining the position of any aircraft/vehicle in the surveillance area and in particular to detect intruders. Examples of non-cooperative surveillance sensors are the primary surveillance radars.

Nuisance Alert

[EUROCAE-MASPS]

Alert, which is correctly generated according to the rule, set but are inappropriate to the desired outcome.

Obstacle

[ICAO-A-SMGCS], page (ix)
[ICAO-Annex14]

All fixed (whether temporary or permanent) and aircraft/vehicle obstacles, or parts thereof, that are located on an area intended for the surface movement of aircraft/vehicles or that extend above a defined surface intended to protect aircraft in flight

Note 1: Definition has been extended to all aircraft/vehicles.

Note 2: In the context of EMMA the following restriction is used: the A-SMGCS shall detect obstacles, whether moving or stationary, located anywhere on the movement area of the aerodrome and having an equivalent radar cross section of 1 sq. m or more.

Protection area

A protection area is a virtual volume around a runway, a restricted area or an aircraft/vehicle. This protection area is used to detect an alert situation. For instance, an alert situation is detected when a aircraft/vehicle is on a runway and one or more aircraft/vehicles enter the runway protection area

Restricted Area

Aerodrome area where the presence of an aircraft or a vehicle is permanently or temporarily forbidden

² The definition is for non cooperative target, where target has been replaced by aircraft/vehicle.

Route [ICAO-A-SMGCS], page (ix)

A track from a defined start point to a defined endpoint on the movement area

Runway Incursion [ICAO-A-SMGCS], page (ix)

Any occurrence at an aerodrome involving the incorrect presence of an aircraft, vehicle or person on the protected area of a surface designated for the landing and take off of aircraft

Stand [ICAO-A-SMGCS], page (x)

A stand is a designated area on an apron intended to be used for the parking of an aircraft

Surveillance [ICAO-A-SMGCS], page (x)

A function of the system, which provides identification and accurate position information on aircraft, vehicles and obstacles within the designated area

Target [ICAO-A-SMGCS], page (x)

An aircraft, vehicle or other obstacle that is displayed on a surveillance display.

Note: This definition has been preferred to the [EUROCAE-MASPS] definition..

Visibility Conditions [ICAO-A-SMGCS],
appendix A-2-1

Four Visibility Conditions are defined as follows in the ICAO A-SMGCS Manual:

Visibility Condition 1

Visibility sufficient for the pilot to taxi and to avoid collision with other traffic on taxiways and at intersections by visual reference, and for personnel of control units to exercise control over all traffic on the basis of visual surveillance.

Visibility Condition 2

Visibility sufficient for the pilot to taxi and to avoid collision with other traffic on taxiways and at intersections by visual reference, but insufficient for personnel of control units to exercise control over all traffic on the basis of visual surveillance.

Visibility Condition 3

Visibility sufficient for the pilot to taxi but insufficient for the pilot to avoid collision with other traffic on taxiways and at intersections by visual reference, and insufficient for personnel of control units to exercise control over all traffic on the basis of visual surveillance. For taxiing this is normally taken as visibilities equivalent to a RVR of less than 400 m but more than 75 m.

Visibility Condition 4

Visibility insufficient for the pilot to taxi by visual guidance only. This is normally taken as a RVR of 75 m or less.

1.8 EMMA ORD Partners' Responsibilities

- ORD Coordinator:
 - EEC - Stéphane Dubuisson, Olivier Delain – Editor issues
 - EEC - Roger Lane, Nigel Makins: Operational issues

- ATS Providers:
 - AENA - Francisco J. Rodríguez Angelina, Mario Parra Martínez
 - ANS_CR - Miroslav Tykal, Alexandr Duda
 - DFS - Raimund Weidemann
 - DSNA - Nicolas Marcou, Pascale Henry-Ducos

-
- ENAV - Antonio Nuzzo, Maria Grazia Bechere
 - DLR - Joern Jakobi

 - Aircraft Operators:
 - STAR - Max Körte

 - Reviewer:
 - TATM – Stephane Paul
 - EUROCONTROL – Jean-Pierre Lesueur

2 Operational Concept

This chapter introduces operational concepts and principles associated to A-SMGCS services. Further definition of concepts and principles are provided in the EMMA D.1.3.1u OSED document.

2.1 Operational objectives

The objective of an A-SMGCS is to optimise the efficiency, capacity and safety of operations at an aerodrome. The surface movement infrastructure existing at many airports today can be enhanced by providing positive identification of traffic, improving all weather situation awareness, improving communications and navigation aids, and by providing route planning tools.

Whereas current SMGCS procedures are based on “see and be seen” procedures, the increasing number of operations that take place in low visibility conditions, the progressive increase in traffic, the complexity of aerodrome layouts, the proliferation of capacity-enhancing techniques and procedures has resulted in an increasing number of accidents and incidents. Thus operational objectives have been developed for improving SMGCS (ICAO 9830, section 1-2):

“a) Controllers, pilots and vehicle drivers should be provided with systems of the same level of performance;

b) Controllers, pilots and vehicle drivers should have clearly defined roles and responsibilities that eliminate procedural ambiguities which may lead to operational errors and deviations;

c) Improved means of providing situational awareness should be available to controllers, pilots and vehicle drivers, taking into consideration visibility conditions, operational errors and deviations.

d) Improved means of surveillance should be in place;

e) Delays in ground movements should be reduced, and growth in operations, including runway capacity, should be accommodated.

f) Surface movement functions should be able to accommodate all classes of aircraft and necessary vehicles;

g) Improved guidance and procedures should be in place to allow:

1. safe surface operations on the aerodrome, taking into consideration visibility, traffic density and aerodrome layout; and

2. Pilots and vehicle drivers to follow their assigned routes in an unambiguous and reliable way;

h) Improved aerodrome visual aids providing guidance for surface movements should be an integrated component of the system;

i) Automation and human factors engineering should provide the linkage between the surface and the terminal and between the terminal and the en-route airspace to create seamless operations with reduced controller and pilot workload.

j) SMGCS improvements should be developed in a modular form to accommodate all aerodrome types;

k) conflict prediction and/or detection, analysis and resolution, should be provided”.

2.2 EMMA Services

The OSED document addressed the description of services, together with equipment considerations and potential implementation steps, e.g.:

- **Services to ATCOs**, organised around surveillance, control, routing and guidance primary functions;
- **Services to flight crews**; associated EMMA functions comprise airport moving map, surface movement alerting, braking and steering cues, ground traffic display, CPDLC ground clearance and taxi route uplink, ground/air database upload, traffic conflict detection, HUD surface guidance symbology, automated steering.
- **Services to vehicle drivers**: airport moving map, surface movement alerting and ground traffic display functions, and data link for guidance and dispatch.

3 Regulatory Aspects

3.1 Air Traffic Service Provider

The current provisions governing an aerodrome control service are laid down in ICAO PANS-ATM (Doc. 4444) chapter 7 "Procedures for aerodrome control service". In particular it is stated that:

*"Aerodrome control towers shall **issue information and clearances** to aircraft under their control...with the object of preventing collision(s)"*

and:

*"Aerodrome controllers shall **maintain a continuous watch on all flight operations** on and in the vicinity of an aerodrome as well as vehicles and personnel on the manoeuvring area. **Watch shall be maintained by visual observation, augmented in low visibility conditions by radar**"*

In the case of surface movement radar, the nature of this augmentation is laid down in PANS-ATM chapter 8 as follows:

"The information displayed on an SMR display may be used to assist in:

- a) Monitoring of aircraft and vehicles on the manoeuvring area for compliance with clearances and instructions;*
- b) Determining that a runway is clear of traffic prior to a landing or take-off;*
- c) Providing information on essential local traffic on or near the manoeuvring area;*
- d) Determining the location of aircraft and vehicles on the manoeuvring area;*
- e) Providing directional taxi information to aircraft when requested by the pilot or deemed necessary by the controller. Except under special circumstances, e.g. emergencies, such information should not be issued in the form of specific heading instructions;*
- f) Providing assistance and advice to emergency vehicles."*

In the ATS Planning Manual (ICAO Doc. 9426) the use of SMR is summarised as follows:

*"SMR can make **a valuable contribution** to the safety and efficiency of aerodrome surface movement control **in low visibility conditions and at night**. However, it should be emphasised that **SMR is an adjunct and not an alternative** to the visual aids and procedures currently used for the control of aircraft and vehicles on the manoeuvring area."*

Additionally, for the control of surface traffic in low visibility conditions it is stated (in ICAO Doc 4444 §7.10.1.1 and Doc 9476³) that:

"When there is a requirement for traffic to operate on the manoeuvring area in conditions of visibility, which prevent the aerodrome control tower from applying visual separation between aircraft, and between aircraft and vehicles, the following shall apply:"

- "At the intersection of taxiways, an aircraft or vehicle on a taxiway shall not be permitted to hold closer to the other taxiway than the holding position limit..."*

³ Manual of Surface Movement Guidance and Control Systems (SMGCS), doc 9476-AN/27

- *"The longitudinal separation on taxiways shall be as specified for each particular aerodrome by the appropriate ATS authority."*

The use of words such as 'augment', 'assist' and 'adjunct' in these important documents leads to have discrepancies between different paragraphs in the same document. This leads to different interpretation by different users: e.g. "Radar data should not be used alone in the provision of an aerodrome control service" (i.e. the term 'radar control' is not applicable to aerodrome control using SMR).

The procedures laid down in this document describe how A-SMGCS surveillance data may be used in the provision of an aerodrome control service.

The intention is that the aerodrome controller will be able to use A-SMGCS surveillance data as a replacement for visual observation, when appropriate. It is also intended that the ambiguity surrounding the use of SMR be clarified.

3.2 Aircraft Operator

3.2.1 Basic Framework

The Civil Aviation Authorities of certain European countries have agreed on detailed aviation requirements referred to as Joint Aviation Requirements (JAR).

EMMA JAR-OPS 1 is used as a reference for regulations of commercial air transport operations. ICAO Annex 6 has been selected to provide the basic structure of JAR-OPS 1.

The requirements in JAR-OPS 1 are applicable:

"For operators of aeroplanes over 10 tonnes Maximum Take-Off Mass or with a maximum approved passenger seating configuration of 20 or more, or with mixed fleets of aeroplanes above and below the discriminant."

3.2.2 Specific Framework for Commercial Operators

For each operator the Operations Manual (OM) describes in detail rules and regulations that have to be complied with when involved in commercial air transportation. The content of the Operations Manual must be in accordance with JAR-OPS 1 Subpart P and be approved by the respective authority.

The authority of the commander as well as crew responsibilities of the entire flight crew is described in detail in the OM.

Note: Non commercial operators or operators of small aircraft which that are not regulated by JAR-OPS 1 are not addressed in section 3.2

4 Transponder Operating Procedures

The use of a surveillance display, instead of the present visual activity of the controller for aerodrome control procedures, has introduced the notion of "identification" of traffic on that display. Today the surveillance systems in use or expected to be used in a short term are based on Mode-S transmission of identification data.

It is mandatory for air traffic control to identify (and verify when being the "first in the loop") the aircraft ID prior to use the surveillance display.

For that purpose, flight crews should input data and set their transponder box. This introduces some changes from the present aircrew operating procedures that are described in the Eurocontrol 'Draft Operating Procedures' document (edition 1.5, 01/12/04) .

4.1 Departure

4.1.1 At the gate / stand

Select STBY

- Enter the discrete mode A code received from ATC;
- According to aircraft equipment, enter the Airline 3-letter ICAO designator, followed by the flight identification number through the FMS or the Transponder Control Panel.

These operations will prepare the transponder to start exchanging data with no delay when needed.

4.1.2 On requesting push back / taxi (whichever is earlier)

Select XPDR

At this time the aircraft ID (used as the call sign by ATC) will be displayed on the surveillance display giving the opportunity to ATC to process the mandatory identification procedure (and verification of data's) before to use the radar data.

4.1.3 When Lining Up

Select TA/RA

To ensure that the performance of systems based on SSR frequencies (including airborne TCAS units, SSR and A-SMGCS) is not compromised; TCAS should not be selected before receiving the clearance to line up.

4.2 Arrival

4.2.1 When Still on the Runway

Keep TA/RA selected

4.2.2 After Vacating the Runway

Select XPDR

There is a need that the transponder remains able to exchange data with the A-SMGCS system. However, to ensure that the performance of systems based on SSR frequencies (including airborne

TCAS units, SSR and A-SMGCS) are not compromised, TCAS should be deselected when vacating the runway.

4.2.3 Fully Parked on Stand

Select STBY

When STBY is selected, the transponder is not transmitting or replying to interrogation. The discrete Mode A code given to that particular flight can be recycled for other flights.

4.3 Miscellaneous

These procedures cover other needs than departure and arrival (e.g. an aircraft needed to move on a taxiway between two stands could be given a conspicuity code (i.e. A1000) and will apply the same procedures.

If vehicles are Mode-S transponder equipped, drivers should apply local transponder operating procedures agreed by ANSP that should not interfere with aircraft transponder operation.

4.4 ADS-B issues

The first implementations and use of ADS-B on airport and onboard show some discrepancy between the positions given by ADS-B system and the position given by other sensors (MLAT, SMR), which are considered as more accurate. The same applies also for the identification capability. For this reason, it has often been decided by test sites not to take the ADS-B input into account in the computation of the position and identification at the SDF (Sensor Data Fusion) output. This critical issue will be addressed in EMMA2. The following guidelines could be considered for this study:

1. The first task is to ensure that the technical capabilities of ADS-B are sufficient to be used in an A-SMGCS, without inducing controller and pilot additional workload. The related technical requirements on position accuracy and probability of identification could be the same as the ones defined for the performances of the SDF output (see TRD). This is the main issue. ADS-B can be used for A-SMGCS only, when the respective standards and requirements exist, and all ADS-B equipment and the integration strictly follow the standards and requirements, and when the data quality is according to the requirements given by the A-SMGCS. At the time this is not guaranteed, since ADS-B is in a relatively early implementation state, and not all equipment providers and airlines seem to be aware of the situation.

Concerning the data quality it must be distinguished between the different data types:

- a) The accuracy of surface position data (Extended Squitter DF17:BDS06 = speed, heading, Lat, Long), depends on the capabilities of the aircrafts navigation and avionics equipment. It is a technical issue of equipage that together with ADS-B an appropriate navigation data source has to be installed. ED102, chapter 3.1 states an example for applications and required data sources.
 - b) The aircraft category and ID data (DF17:BDS08) consists of the category and the tail number, which have to be programmed into the address module of the Mode-S transponder at installation time. It is a technical issue of checking and maintenance, that the right numbers are programmed.
 - c) When available, the flight number will be transmitted instead of the tail number. The flight number has to be entered by the pilot during flight preparation. It is an operational issue to check that the right number has been entered for the respective flight.
2. An operational requirement for A-SMGCS higher levels implementation should be created, which states that the pilot and the controller should share the same situation awareness. This

situation awareness could be limited to the position and identification of the aircraft, or extended to the surrounding traffic.

3. Control and pilot procedures may have to be defined in order to detect, and to manage the situations of discrepancy. However, this would increase the pilot's or controller's workload and probably wouldn't be accepted by them. The human should not be exploited to keep a low-matured technical system running. This would be a week work-around on the cost of the user who we wanted help basically.

In general, the following statements can be formulated:

- As long as ADS-B does not provide the required ground position accuracy for every equipped aircraft, it is not usable for A-SMGCS, since it will degrade the SDF output, as long as the SDF does not provide specific means to overcome the problem. A declined or unreliable position accuracy degrades the safety produced by the A-SMGCS, increases the workload of controllers and pilots, and reduces the confidence of the controllers and pilots in a safety critical tool.
- It can not be tolerated, that certified equipment by daily operation deviates from the respective standards and requirements. If ADS-B equipment fails to perform as required, this has to be monitored and reported, and maintenance conducted.
- If in the A-SMGCS at an airport the ADS-B capability of the transponder of a single aircraft is degraded, which should be the exception, this has to be handled like the failure of other aircraft equipment, and a respective fallback procedure applied. Since this is an exception, the controller can live with the additional workload required.
- ADS-B is a component of A-SMGCS surveillance step 1. Since a reliable surveillance is the technical basis for other services, any degradation of the surveillance will cause also the degradation of the other services. This has the consequence, that fallback procedures must be applied not only for surveillance, but also for higher functionalities.
- There may be also technical solutions to cope with a degraded position accuracy of ADS-B. One solution could be to use of a figure of merit data item for the position information, which enables the SDF to decide whether the tracking of an aircraft includes ADS-B or not.
- For a wrong call sign entered by the pilot and detected by the controller there can be a similar procedure as nowadays for a false squawk.

5 Visibility Transitions

5.1 Definition of values for A-SMGCS visibility threshold

There are four visibility conditions defined in the A-SMGCS manual and there is a need to define the transition between each of these as these transitions may require the use of different rules.

Also, rule governing the transmission of visibility (or RVR) and operational data are already defined by ICAO.

5.2 ICAO A-SMGCS Manual Definitions

The ICAO A-SMGCS Manual (Doc 9830, annex A, section 2) provides definitions of four visibility conditions:

a) Visibility condition 1 (VIS.1)

Visibility sufficient for the pilot to taxi and to avoid collision with other traffic on taxiways and at intersections by visual reference, and for personnel of control units to exercise control over all traffic on the basis of visual surveillance;

b) Visibility condition 2 (VIS.2)

Visibility sufficient for the pilot to taxi and to avoid collision with other traffic on taxiways and at intersections by visual reference, but insufficient for personnel of control units to exercise control over all traffic on the basis of visual surveillance;

c) Visibility condition 3 (VIS.3)

Visibility sufficient for the pilot to taxi but insufficient for the pilot to avoid collision with other traffic on taxiways and at intersections by visual reference, and insufficient for personnel of control units to exercise control over all traffic on the basis of visual surveillance. For taxiing this is normally taken as visibility's equivalent to a RVR of less than 400 m but more than 75 m; and

d) Visibility condition 4 (VIS.4)

*Visibility insufficient for the pilot to taxi by visual guidance only.
This is normally taken as a RVR of 75m or less.*

Note. - The above visibility conditions apply for both day and night operations.

It is not stated if “visibility” is referring to horizontal visibility, as provided by the Meteorological Office to ATS.

5.3 Air Traffic Control operational concerns

5.3.1 Visibility Condition 1

Nothing involving the use of A-SMGCS.

5.3.2 Visibility Condition 2

During Visibility Condition 2 (which could be caused by either ceiling or horizontal visibility), control over the traffic can no longer be exercised on the basis of visual reference. When horizontal visibility

is the main reason for Visibility Condition 2, both pilots and air traffic controllers will have reduced visual reference and their situational awareness is modified as follows:

- The Controller is unable to assess the traffic situation visually and will then have to make more use of the surveillance display;
- The pilot is less able to anticipate other traffic and apply the “see and avoid” principle.

If the ceiling is the reason for Visibility Condition 2, this may affect only the air traffic controller. Pilots taxiing on the ground may not experience any change to their situational awareness and may not be aware of the change to the controllers’ situational awareness (e.g. still taxiing at a high speed).

There may be a need to warn aircrew of the ATC change of situational awareness when the value of the cloud base is the fact that makes ATC applying VIS.2 conditions.

5.3.3 Visibility Condition 3

To avoid collision, within the provision of air traffic control services, there are two methodologies: Separation or Traffic information.

5.3.3.1 Separation

There are currently no separation standards on the ground. Traffic information is given to pilots so that they can avoid other traffic (by distances determined through their own judgement).

5.3.3.2 Traffic Information

In the air, when traffic information is mandatory to provide Air Traffic control Service (e.g. for VFR against IFR in Class D airspace or in controlled runway traffic pattern), meteorological minima are established (horizontal and vertical values) to help ensure the success of traffic information.

When traffic information is not successful (this may be the case when the actual visibility experienced by the pilot is at the limit of VMC⁴), the issuance of “avoiding action” by the controller -even if this has not been requested by the pilot- is available as an ultimate “last solution”. However, this is outside of the strict application of the regulatory provisions. And if there are three dimensions in the air, on the ground there is not too much solution to avoid.

5.3.4 Application to Movements on the Surface

5.3.4.1 Preamble

When establishing a threshold visibility for the commencement of Visibility Condition 3 for which ICAO propose a value of less than 400m, it should be kept in mind that it will normally be measured near the runway in the landing/take-off direction (as a Runway Visual Range). There are two or three Runway Visual Range (RVR) measurements per runway that could be different one from the other. Most of the taxiways are not lighted with the powerful projectors that equip runways. Pilots (and drivers) could therefore experience visibility conditions on the taxiways that are different from the measured RVR.

5.3.4.2 Application to “see and avoid”

It is believed that during Visibility Condition 2 the pilot can still assume the “see and avoid” principle to avoid collision, with the ATC service providing appropriate traffic information and instructions.

Consequently, there is a need to set up a visibility threshold above which the pilot will be able to identify conflicting traffic with a very high rate of success.

⁴ The worst existing VMC (Visual Meteorological Condition) about visibility in controlled airspace C,D or E below FL100 is 5 km

Below this threshold it is assumed that the pilot will no longer be able to see and avoid other traffic. ATC would then revert to procedural control, using any kind of tool design for that purpose. Capacity will be reduced but R/T workload should be expected to remain acceptable with the use of surveillance display to reduce the need for position reports.

5.3.4.3 Need for a Buffer

It is therefore apparent that the value set for the transition to Visibility Condition 3 includes a buffer to allow for the potential difference between the measured visibility (at the runway as RVR) and the actual visibility experienced by a pilot elsewhere on the manoeuvring area (to avoid that a pilot taxi after the point e.g.; at an intersection of taxiway where she/he is protected from the intersection subject to ICAO ANNEX 14 definition, used under procedural control as defined below.)

5.3.4.4 Limit of the Concept

To keep a parallel interpretation with the problem of traffic information in class D airspace, on the ground there will be no escape solution as soon as one of the traffic involved, for example in a taxiway crossing conflict, has passed the procedural holding point.

5.3.5 Existing Transition Values

The problem of using an airport under limited visibility has been already taken into consideration as follows:

- First by the JAA to protect precision approach but also including restrictions to protect ground movements (400m is the value where LVP should be enforced).
- In 2001 ICAO included some provisions in the Doc 4444 (section 7.10). The visibility value specified to enforce additional constraints to allow commencement of CATII and III approaches is 550m.
- In the ICAO LVP draft manual it is stated that “*Pilots can be expected to see and avoid other ground traffic at visibilities of 400m RVR or more*”.
- In a NASA study it is stated “*In the terminal area context, low visibility (RVR 300m) conditions result in slower taxi operations, resulting in a significant decrease in the efficiency in bringing aircraft in and out of the airport*”.
- In a 2004 EUROCONTROL/ AIRBUS study using airbus simulator, the limit of the visibility to see and avoid has been detected around 250/300m.

5.3.5.1 Consideration on Visibility Condition 1-2 Transition

The change from visibility where the controller can see all the traffic he is controlling to conditions where some traffic can no longer be observed is subject to many considerations depending on airport layout, distance to specific point, or tower configuration. However, in Visibility Condition 2 it is considered that the pilot is still able to see and avoid.

Therefore there will be no change to the sharing in ground movement responsibility with the controller and there is no need to define a transition value between those two conditions.

5.3.5.2 Consideration on Visibility Condition 2-3 Transition

The visibility threshold between Visibility Condition 2 and Visibility Condition 3 should be kept at a minimum value in order to keep the best aerodrome throughput, taking into account the minimum distance needed by a flight crew to receive, interpret and assume the information given on the traffic.

Due to the possible difference between the visibility figures measured at a runway (which are used to implement LVP procedures) and the actual visibility experienced elsewhere on the manoeuvring area,

there is a need to study the need for a buffer that will allow for such a difference (i.e. the likelihood of a lower visibility being experienced on the taxiways & aprons). To stay with the same concept of collision avoidance using traffic information, there is a need to ensure that the ratio of successful traffic information remains very high (this is the reason of establishing VMC criteria linked to airspace classifications and ATC services).

Therefore, if the aircraft involved do not see each other (despite Visibility Condition 2) the controller must be able to revert to a procedural holding instruction (as there is a risk of collision as soon as the ICAO annex14 protection distance on the ground is infringed).

The present ATM obligation requests that LVPs should be enforced when RVR are below 550m. To limit the number of values to be taken into account by ATC there should -if possible- be a common figure for starting operations and procedures linked by the same goal.

5.3.6 Consideration on Visibility Condition 3-4 Transition

The difference between Visibility Condition 3 and Visibility Condition 4 limits is only the inability of the flight crew to taxi by visual reference in Visibility Condition 4. There is a need of a navigational device that is not in the ATM domain (today there is no means that give the ability to a crew to taxi under such conditions).

The value to be determined therefore corresponds to end of Visibility Condition 3; more studies are needed on that subject.

5.4 Summary

There is a need to harmonise the use of new tools and associated procedures in ATM in order that flight crews meet the same procedure structure and organisation wherever they fly.

For ending Visibility Condition 2 conditions/starting Visibility Condition 3 there is a need to define a numerical value, which seems to be founded between 300m and 550m taking into consideration the constraints of section 5.3.3.

It is suggested that the transition from Visibility Condition 2 to Visibility Condition 3 should be coincident with the commencement of LVPs (i.e. 550m). This value will be assessed through real time ATC simulation and by pilots using last generation flight simulators.

6 A-SMGCS phraseology

A-SMGCS is a new ATC tool for which neither procedures nor phraseology are currently available in Doc 4444.

The Eurocontrol A-SMGCS project has therefore set up, a draft set of proposed ATC procedures. Current phraseology included in ICAO Doc 4444 section 12.3.4 and in ICAO Doc 7030 has also been studied in the light of these proposed procedures to determine if changes are required.

6.1 Procedure Changes

There will be no responsibility modification between ATC and flight crews in visibility condition 1 and 2.

Each sub paragraph of Doc 4444 section 12.3.4 (*“phraseologies for use on and in the vicinity of the aerodrome”*) can be associated to their equivalent paragraph in the Eurocontrol A-SMGCS procedures document as follows:

DOC 4444 / DOC 7030 EUR	Eurocontrol A-SMGCS Project draft procedures
12.3.4.3 Starting procedures	Pre Departure Clearance
12.3.4.4 Push back procedures	3.2 Push-back, Power back and towed-out
12.3.4.5 TOWING PROCEDURES	Clearance
12.3.4.7 Taxi procedures	3.3 Taxi Clearance
12.3.4.7 Taxi procedures i) n) o) p)	5.1 Taxiing on the runway
12.3.4.7 Taxi procedures d) g) h) n) t)	3.4 Control of taxiway intersection
12.3.4.8 Holding	3.3 Taxi Clearance
12.3.4.10 Preparation for take off	5.2 Line up procedures
2.0 Intersection Take off (Doc7030)	5.2.2 Intersection take off
3.0 Multiple line-up on the same runway (Doc7030)	5.2.3 multiple line up
12.3.4.11 Take off clearance	5.3 Take off Clearance
12.3.4.16 Landing	5.4 Landing Clearance
12.3.4.20 Runway vacating and communications after landing	3.3 Taxi Clearance
12.2 General	5.5 Conditional Clearance
12.2.4 Conditional phrases	

As in the use of airborne radar procedures, it is necessary to identify traffic using A-SMGCS Surveillance data as the basis, before issuing a clearance to an aircraft. However as the ATC service provided to aircraft on the ground will not change it should not be mandatory to report to the pilot, that A-SMGCS surveillance was used as the basis upon which the clearance was formulated.

Note: in VIS.1 Conditions either visual confirmation or A-SMGCS surveillance display can be used.

In that case, in the ICAO documentation, a note is added that specifies the condition of use of specific paragraphs involved with these dedicated considerations.

6.2 The Squawk problem

Concerning phraseology, there is no need to define new items different from existing ones (even if identification is performed via ASMGCS HMI), except for dealing with the "squawk problem":

- If a pilot has not switched his transponder on before asking for push back, or if an arrival has stopped its transponder after landing, the ATCO must tell him/her to put the transponder on for the identification to come back on his HMI. In this context, there are different alternatives for the phraseology to be used:

- “*Squawk IDENT*”. It is probably not the most appropriate phraseology provided that Mode-S could be used, in the future, without Mode A code; and this is usable only if a discrete or conspicuity code is already in the XPDR box.
- “*Squawk ON # Squawk “WXYZ” as the ATCO has always the discrete code available on the flight strip and the ground mode is automatically selected in a MODE S environment*”. This option should be assessed since on the ground, it shouldn't operate as it does when airborne (for TCAS not to be operative);
Note: Czech Republic Air Navigation Services use this phraseology when pilots forgot to switch it on.
- “*Check if transponder is operating*”.
- As there is a manual human action done by pilot to enter the call sign (via FMS for example), if he/she has entered a wrong data, the ATCO has to contact the pilot. The phraseology for such situations could be:
 - “*Wrong identification, check transponder*”;
 - “*No identification, check transponder*”.

Note: EMMA validation should provide operational feedback on assumptions above (phraseology issues).

7 Operating Procedures for Air Traffic Control

7.1 Introduction

Sections 7, 8 and 9 are dedicated to ATC (section 7), flight crews (section 8) and vehicle drivers' (section 9) operating procedures.

The initial choice was made to group possible operating procedures by users. Nevertheless, during EMMA2 and based on consolidated implementation packages identified in the OSED document, emphasis might be put on re-organising these sections to adopt an implementation-oriented structure considering all involved users (see table 5.2, OSED-update document).

Section 7.2 addresses A-SMGCS procedures linked to identification issues (aircraft, vehicles and obstacles).

Section 7.3 aims to establish the current chronological and operational practice in use by Airport ATC, from the initial clearance delivery to the holding position and from clearing the runway to engine stop at the gate for arrival. By applying future and expected A-SMGCS surveillance capability, procedures should be reviewed, adapted or changed if it seems necessary.

7.2 Identification Procedures

According to ICAO A-SMGCS Manual (9830), “the surveillance function should, depending on the procedures in use, be capable of determining the position and identification of aircraft and vehicles on the movement area, including obstacle free-zones and protected areas. The surveillance function should identify and provide the call sign of each aircraft and vehicle and correlate the call sign with its position. The type of aircraft, including any variety, should be identified and verified. The position of obstacles should be appropriately marked”.

Whereas ICAO envisages one step implementation for surveillance function, the OSED-update document specifies three implementation steps for implementing the surveillance function that relies mainly on complexity, equipment cost and certification, and validation.

- **S1:** the first step refers to manoeuvring area where the visibility could be restricted and for safety. This encompasses the detection and accurate position of all aircraft, vehicles and position of obstacles as well as the identification of all cooperative aircraft and vehicles in the manoeuvring area.

All authorised movements shall be properly equipped to enable automatic identification. However, it should also be possible for ATC to cope with a very limited number of non-cooperative aircraft/vehicles (for covering cases such as grass cutting vehicle, aircraft with transponder out of service), which will not be labelled.

- **S2:** the second step extends to the zone of movement, but exclusively to aircraft⁵. In the same way as for the manoeuvring area, the surveillance service should also cover aircraft in the apron area as controllers deliver push-back clearances when aircraft are on the apron area. Aircraft are expected to be cooperative so the surveillance service will automatically provide their identity.

- **S3:** the third one extends to all vehicles but considering that on the apron, an A-SMGCS applies only to those areas where manoeuvring aircraft may come into conflict with each other or with vehicles. ICAO A-SMGCS manual specified that “at aerodromes operating an A-SMGCS, all vehicles required to move on the movement area should be equipped to use the system. However, to be so equipped is unnecessary and uneconomical for those vehicles that service aircraft on the stand only because they only move onto the stand once the aircraft has parked” (3.5.16.1). In addition, “it is not

⁵ This is due to the cost of capability extension to vehicles.

practicable to exercise total control over all traffic on the movement area. On the apron, an ASMGCS applies only to those areas where manoeuvring aircraft may come into conflict with each other or with vehicles. Therefore, one requirement is to restrict the movement of vehicles on the apron to designated areas and routes. It is also necessary to keep service vehicles away from an active stand. This can be achieved by having painted lines that outline the areas to be left clear when a stand is active. Alternate means of protecting an active stand might become available as a result of technology. It is important that any new solutions retain flexibility to enable an ASMGCS to operate fully during aircraft movements and, in addition, permit service vehicles access to the stand once the aircraft has parked” (3.5.16.3). Setting up appropriate procedures is not mature enough but should be considered during EMMA2.

The following sections detail procedures associated to standard, contingency (when A-SMGCS surveillance identification cannot be applied) and lost identification. Detection and identification procedures apply to all steps (S1 to S3).

7.2.1 Standard A-SMGCS identification procedures

A-SMGCS surveillance identification shall be undertaken using the following actions:

- **For aircraft: direct recognition of the aircraft identification of a Mode-S² equipped aircraft in a surveillance label;**

The aircraft identification feature available in Mode-S transponders provides the means to identify directly individual aircraft on surveillance displays and thus offers the potential to eliminate ultimately the recourse to Mode A discrete codes for individual identification. This elimination will only be achieved in a progressive manner depending on the state of deployment of suitable ground and airborne installations.

- **For vehicles: direct recognition of the vehicle identification of a suitably equipped³ vehicle in a surveillance label;**

The A-SMGCS surveillance service will display the identity of all vehicles in a label attached to the corresponding target. The automatic labelling of a vehicle implies the use of on-board cooperative surveillance equipment that provides an unambiguous vehicle identity to A-SMGCS. Since there are no ICAO transponders requirements for vehicles, vehicles will be equipped with any one of the system available in the industry, providing that vehicles’ identity is not ambiguous.

- **For obstacles:**

Cooperative obstacles, i.e. aircraft or vehicle temporarily stopped on the surface movement area shall be identified according to the standard identification procedures described above for aircraft and vehicles.

Non cooperative obstacles shall be detected by Surface Movement Radar and their associated position displayed on the surveillance display.

However, deciding about **operational usefulness** to detect obstacles and its operational consequences (and determination of types of obstacles to be detected) will be answered at the end of EMMA2.

² Or any kind of equivalent tool that provides co-operative exchanges between aircraft and the ground surveillance system (e.g.; ADS-B)

³ Many systems can fit for that purpose which are or not linked with the Mode-S system. Each vehicle should have its own individual system address

7.2.2 Contingency A-SMGCS identification procedures

This section describes the attitude to adopt when the A-SMGCS surveillance identification cannot be applied.

When the direct recognition of aircraft/vehicle ID through the surveillance label is no longer possible, due to:

- Individual aircraft/vehicle failure of co-operative tool (e.g. transponder), or
- A ground control system failure (e.g. multilateration), or
- Aircraft or vehicle not equipped with Mode-S transponder (e.g. GA, snowplough vehicles, etc.),

The surveillance display is downgraded to a lower level of surveillance, such as SMGCS surveillance display (e.g. labelled SMR) or SMR display only, subject to the quality of the contingency surveillance tool available after failure(s).

In that case the procedures already established by ICAO in Doc 4444 section 8.10.2.3 are applied as hereafter:

Where SMR is used, aircraft may be identified by one or more of the following procedures:

- a) By correlating a particular radar position indication with:
 - i) An aircraft position visually observed by the controller;*
 - ii) An aircraft position reported by the pilot; or*
 - iii) An identified radar position indication displayed on a surveillance radar display.**

Note: It could be e.g.:

- Entering a runway or taxiway intersection;
- Abeam a building or airfield feature which either shows as a permanent echo on the display, or is marked on the video or appropriate reference document (e.g. crash grid map);
- On a taxiway or runway, provided that there are no other unidentified vehicles or aircraft on that runway or taxiway segment.

- b) By transfer of radar identification when authorised by the appropriate ATS authority; (using methods described in Doc 4444 section 8.6.3 "transfer of radar identification" apart e) f) which are not relevant on a ground surveillance display).*

and

- c) By automated identification procedures when authorised by the appropriate ATS authority.*

Reminder from preceding section: aircraft and vehicle radar position indications may be displayed in symbolic or non-symbolic form. Where radar labels are available for display, the capability should be provided for inclusion of aircraft and vehicle identification by manual or automated means (Doc 4444 section 8.10.2.3).

7.2.3 Lost identification

When the identification function fails, the automatic track labelling no longer operates correctly and the aircraft/vehicle identification is either not presented or incorrect.

The loss of identification could have several causes including human error (e.g. input of incorrect information in the transponder) or system failure.

The loss of the label does not necessarily mean the controller has lost the identification of the aircraft/vehicle because the mental picture and flight strips are still available.

The impact that such loss will have on safety and controller workload mainly depends on:

- The number of aircraft/vehicles without identification;
- The traffic density;
- The visibility conditions including night or day;
- The aerodrome layout;
- The control of aircraft/vehicles referring mainly on display information.

If identification is lost, the pilot shall be informed accordingly and, when applicable, appropriate instructions shall be issued.

As a contingency measure/back up system, the procedural control using the flight strips should always be kept updated.

7.3 Standard ATC Procedures Description

Each procedure is described through four items:

- Current procedures without A-SMGCS;
 - When traffic is visible to the Controller;
 - When traffic is hidden by permanent obstacle with or without SMR;
 - When traffic is not visible to the Controller due to low visibility with or without SMR;and
- The future;
 - What is expected with the use of an A-SMGCS.

Identification is a prerequisite for the provision of any form of radar service and is defined as:

“The situation that exists when the radar position of a particular aircraft is seen on a radar display and positively identified by the air traffic controller”.

The procedure as it exists today is aimed at the use of radar, e.g. PSR, SSR and SMR, and in the A-SMGCS environment we need identification procedures that are appropriate for already existing, MLT, ADS and perhaps others.

7.3.1 ATC/Start-Up Clearance

ICAO prescribed procedures that are applicable for the delivery of ATC clearances prior to start-up, are not specifically described.

One function of the Clearance delivery sector is to activate the FPL/RPL “life” by imputing the FDPS with the start up request of the flight crew.

At this time, and according the sophistication level of the input device and automated information display, ATC should need to know:

- The gate number;

- The runway that will be used by the flight and FPL data's to set up ATC clearance;
- The flow management constraints;
- The discrete SSR code;
- All supplementary information which could be stated in the AIP.

The flight crew can transmit by R/T or data link relevant information needed on the flight but not known yet by ATC.

After ATC clearances (SID, SSR code, Slots. etc) are relayed to the flight crew, start up can be approved or this clearance could be requested or transmitted on the ground control frequency.

All those exchanges could be performed by data link. Being able to see outside is not mandatory for the controller and at some locations the clearance delivery position is not in the tower visual control room.

A-SMGCS Regulation

A-SMGCS surveillance tool may have very limited opportunity to improve the ATC process at this working position.

7.3.2 Push-Back Clearance

(Note: Definitions for Power Back and Towed Out procedures to be developed by ICAO)

7.3.2.1 When Gates are Visible to the Controller

ATC actions are as follows:

- ATC check that the aircraft requesting clearance is positioned at the right gate;
- According to the situation of other traffic already taxiing, pushing or towing:
 - Clearance to leave the gate is approved;
 - Clearance to leave the gate is delayed;
 - A conditional clearance is transmitted subject to potential conflicting traffic.

A-SMGCS Regulation

A-SMGCS surveillance (in VIS.1) could provide positive information for total situational awareness on what is happening on the manoeuvring area when gates are visible to the controller but distant from the ground control working position.

The aircraft ID will be displayed at the gate;

The A-SMGCS identification procedures defined in section 7.2 should be performed;

“See and avoid” by pilots after traffic information is done by ATC will continue to be applied.

7.3.2.2 When Gates are not visible to the Controller

7.3.2.2.1 Due to Layout or Permanent Obstacle

ATC actions are as follows:

- ATC check that the aircraft requesting clearance is positioned at the right gate by checking with the pilot or using supplemental tools (e.g. SMR) agreed on a local basis.
- Then resume as 7.3.2.1 when visual contact is established with the traffic.
- If an SMR is available, and if the radar covers the area of the gate concerned, the arriving of the aircraft on the manoeuvring area could be confirmed with this tool.

A-SMGCS Regulation

The A-SMGCS surveillance tool provides the aircraft ID at the gate on the controller's display, helping to remove the use of supplemental tools to check the exact position of the aircraft.

The A-SMGCS identification procedures defined in Chapter 4 should be performed.

The A-SMGCS surveillance regulation will replace the SMR regulation. To assume that push back or towed out clearance can be executed with no potential conflict on the manoeuvring area, the ground controller can rely on the identified aircraft and vehicles positions on the surveillance display.

- Under VIS.1 and VIS.2 conditions - as far as the flight crew is concerned - the present ruling conditions "see and avoid" will continue to be applied.
- VIS.3 conditions require the study of appropriate provisions linked to the ability of ATC to use such provisions by reference to a surveillance display. An intermediate solution should be the use of procedural R/T reports released by ATC upon the use of the surveillance display.
- VIS.4 conditions require the study of appropriate provisions associated with the implementation of guidance tools for the pilot, ATCO and vehicle driver.

7.3.2.2.2 Due to Low visibility

ATC actions are as follows:

- ATC check that the aircraft requesting clearance is positioned at the right stand by asking the pilot on R/T.
- ATC control mainly through a procedural process, using planning devices (e.g. the flight strip display etc.) and position reports requested from flight crews at specific point or stop bars, in order to plan and transmit the ATC clearances to the aircraft leaving the stand.
- If an SMR is available, and if the radar covers the area of the stand concerned, the arriving of the aircraft on the manoeuvring area could be confirmed with this tool.

A-SMGCS Regulation

The A-SMGCS surveillance tool will provide on a controller's display an approved situation of identified aircraft/vehicles, thus providing him/her with accurate real time situation awareness.

The A-SMGCS identification procedures defined in section 7.2 should be performed.

The A-SMGCS surveillance regulation replaces the SMR regulation.

- Until end of VIS.2 conditions, as far as the flight crew is concerned, the present ruling conditions "see and avoid" will continue to be applied.
- VIS.3 conditions require the study of appropriate provisions, linked to the ability of ATC to use such provisions by reference to a surveillance display. An intermediate solution should be the use of procedural "reports" released by ATC upon the use of the surveillance display.
- VIS.4 conditions require the study of appropriate provisions, associated with the implementation of guidance tools for the pilot, ATCO and vehicle driver.

7.3.3 Taxi Clearance

7.3.3.1 When the manoeuvring Area is visible to the Controller

ATC actions are as follows.

- ATC check that the aircraft requesting clearance is positioned at the right stand (departure)⁶;
- Transmit the taxi clearance if no potential conflict is expected in the near future;
- Delay the taxi clearance;
- Transmit a taxi clearance according to one or more conflicting traffic in the vicinity.

A-SMGCS Regulation

A-SMGCS surveillance (VIS.1) helps to provide positive information for total situational awareness of what is happening on the manoeuvring area when aircraft on taxiways are visible but remote from the ground control working position. The aircraft ID will be automatically displayed and maintained within an approved regulation environment so that ATC can rely on it.

The A-SMGCS identification procedures defined in section 7.2 should be performed

Subject to present situation, the ATC service is performed equally “head-up” or “head-down” according to the “best” information quality available, looking outside or on the surveillance display.

7.3.3.2 When the Manoeuvring Area is not visible to the Controller

7.3.3.2.1 Due to Layout or Permanent Object

ATC actions are as follows:

- ATC verify that the aircraft requesting clearance is positioned at the right stand by relying on the pilot message or using supplemental tools agreed on a local basis;
- Then resume as 7.3.3.1 the aircraft is visible to the controller;
- If an SMR is available, and if the radar covers the area concerned, the monitoring of the aircraft compliance with the clearance on the manoeuvring area could be performed with this tool as the aircraft/vehicle has been correctly identified.

Reminder: the use of SMR is related to the operational conditions and requirements of the aerodrome (i.e. traffic density, aerodrome layout, visibility conditions).

A-SMGCS Regulation

The A-SMGCS surveillance tool provides on a display an approved situation of identified aircraft and vehicles. The A-SMGCS surveillance regulation replaces the SMR regulation.

To ensure that taxi clearance can be executed with no potential conflict on the manoeuvring area, the ground controller can rely on the identified aircraft and vehicles positions on the surveillance display.

The A-SMGCS identification procedures defined in section 7.2 should be performed:

⁶ This paragraph addresses both departures and arrivals; regarding arrivals, when necessary or desirable in order to expedite traffic, a landing aircraft may be requested to hold short of an intersecting runway after landing; or land beyond the touchdown zone of the runway, or vacate the runway at a specified exit taxiway, or expedite vacating the runway. ATC action is to check that instructions have been followed.

- Until end of VIS.2 conditions, as far as the flight crew is concerned, the present ruling conditions “see and avoid” will continue to be applied;
- VIS.3 conditions require the study of appropriate conditions, linked to the ability of ATC to use such provisions by reference to a surveillance display. An intermediate solution should be the use of procedural “reports” released by ATC upon the use of the surveillance display;
- VIS.4 conditions require the study of appropriate provisions associated with the implementation of guidance tools for the pilot, ATCO and vehicle driver.

7.3.3.2.2 Low Visibility

ATC actions are as follows:

- ATC rely on the aircraft position given by the flight crew requesting taxi clearance.
- ATC control mainly through a procedural process, using planning device (e.g. the flight strip display) and using position reports requested from flight crews at specific point or stop bars, in order to plan and transmit the ATC clearances to the aircraft leaving the gate.
- If an SMR is available, and if the radar covers the area concerned, the monitoring of the aircraft compliance with the ATC clearance on the manoeuvring area could be performed with this tool, as soon as one of the identification procedures has been applied successfully to it (ICAO Doc 4444, section 8.10.2.2.2).

Note: The use of SMR is related to the operational conditions and requirements of the aerodrome (i.e. traffic density, aerodrome layout, visibility conditions).

A-SMGCS Regulation

The A-SMGCS surveillance tool provides on a display an approved situation of identified aircraft and vehicles.

The A-SMGCS surveillance regulation replaces the SMR regulation.

The A-SMGCS identification procedures defined in section 7.2 should be performed.

- Under VIS.1 and VIS.2 conditions, as far as the flight crew is concerned, the present ruling conditions “see and avoid” will continue to be applied;
- VIS.3 conditions require the study of appropriate provisions, linked to the ability of ATC to use such provisions by reference to a surveillance display;
- An intermediate solution should be the use of procedural “reports”, released by ATC upon the use of the surveillance display;
- VIS.4 conditions require the study of appropriate provisions associated with the implementation of guidance tools for the pilot, ATCO and vehicle driver.

7.3.4 Control of Taxiway Intersection

7.3.4.1 When the Intersection is Visible to the Controller

ATC actions are as follows:

- As ATC is maintaining a continuous watch on all operations on the aerodrome, if a risk of conflict occurred it should be detected by ATC, with the help of the planning tool, e.g. flight strips display etc).

- When a potential conflict is detected at an intersection, clearances or instructions are transmitted to aircraft together with traffic information in order to achieve a safe and orderly flow of traffic. It is up to the flight crew to decide which distance is needed to cross behind or to follow the previous aircraft as no separation standards applied. Jet blast and propeller driven aircraft slipstream warnings may still need to be given.

A-SMGCS Regulation

A-SMGCS surveillance (VIS.1) helps to provide positive information for total situational awareness on what is happening on the manoeuvring area, especially at taxiways intersections when aircraft on taxiways are visible from the controller but far away from the ground control working position. The flight ID will be automatically displayed and maintained within an approved regulation environment so that ATC could rely on it. Subject to present situation, the ATC service is performed equally “head-up” or “head-down”.

7.3.4.2 When the Intersection is not visible to the Controller

7.3.4.2.1 Due to Layout or Permanent Obstacle

If a potential conflict is expected at a taxiway intersection not visible to the controller, detection and resolution by giving priority or stop order is realised as early as possible based on procedural actions, or dedicated tools like stop bars. Flight crews will be asked to report resuming taxiing, after the crossing problem is solved, until traffic is once again visible to the controller.

A-SMGCS Regulation

The A-SMGCS surveillance tool provides on the controller’s display, the aircraft ID at the exact position the aircraft is.

The A-SMGCS surveillance regulation replaces the SMR regulation.

To assure that clearances or instructions can be executed with no potential conflict on the manoeuvring area, the ground controller can rely on the identified aircraft/vehicle positions on the surveillance display. The controller will also be able to monitor compliance with the control instruction.

- Under VIS.1 and VIS.2 conditions, as far as the flight crew is concerned, the present ruling conditions “see and avoid” will continue to be applied;
- VIS.3 conditions require the study of appropriate provisions, linked to the ability of ATC to use such provisions by reference to a surveillance display; an intermediate solution should be the use of procedural R/T “reports” based upon the use of the surveillance display;
- VIS.4 conditions require the study of appropriate provisions, after that VIS.3 problem is solved for ATC, for the implementation of guidance tools for the pilot, ATCO and vehicle driver.

7.3.4.2.2 Due to low Visibility

ATC actions are as follows:

- ATC control by a procedural process using Planning device (e.g. the flight strip display etc) and reporting position requested from flight crews at specific point: e.g. stop bars, in order to plan and transmit the ATC clearance to the aircraft.
- If a conflict is expected at an intersection, the traffic for which ATC decided not to give priority is instructed to hold short before the holding position defined by clearance bar, stop-bar or taxiway intersection markings.
- If visibility conditions allow it, traffic information is passed to the waiting traffic in order to substitute the procedural action by a visual crossing.

- If a visual crossing failed, ATC will wait for that crossing traffic to report clear of the intersection using procedures prescribed by the appropriate ATS authority.

A-SMGCS Regulation

The A-SMGCS surveillance tool provides on a display an approved situation of identified aircraft/vehicles.

The A-SMGCS surveillance regulation replaces the SMR regulation.

- Under VIS2 conditions, as far as the air flight crew is concerned the present ruling conditions “see and avoid” will continue to be applied.
- VIS.3 requires the study of appropriate provisions linked to the ability of ATC to use such provisions by reference to a surveillance display. An intermediate solution should be the use of procedural R/T “reports” based upon the use of the surveillance display.
- VIS.4 requires the study of appropriate provisions associated with the implementation of guidance tools for the pilot, ATCO and vehicle driver.

7.3.5 Handover between Approach, Departure, Aerodrome, Ground, and Apron Control

7.3.5.1 Co-ordination Ground Controller- Ground Controller

Two situations are envisaged: either ATCOs are located in two different towers or in the same tower.

a) When ATCOs are located in two different towers:

It must be taken into account that:

- No handover is possible for strips, except if they are electronic strips.
- The systems must ensure that each ground sector concerned by a flight has one strip printed for it.
- Both ATCOs must have the same HMI with the same information about traffic on the ground and taxi routes.

For more than 90% of the aircraft which are transferred, no information exchange is needed between two ground sectors because take-off TWY is given by the last Ground ATCO and the taxi trajectories are standardised. So, in such cases, there is no need of coordination between two ground ATCOs.

If there was a need to share specific data, coordination would take place. It would be necessary to have stop bars on taxiways where there is a boundary between two ground sectors. Pilots could then be cleared to taxi to these stop bars and to contact next ground sector. If there is no contact with the next sector, the plane will have to stop and if he has a contact with the next sector ATCO, he could be cleared to continue taxi without stopping.

These procedures could be applied to cooperative aircraft/vehicles and phone coordination should be applied for non cooperative aircraft/vehicles.

A-SMGCS Regulation

The A-SMGCS surveillance tool provides on a display an approved situation of identified aircraft/vehicles.

The A-SMGCS surveillance regulation will replace the SMR regulation.

- In VIS.1 and VIS.2 conditions the automated identification process will provide to both ground controllers with the same traffic situation avoiding the need to request additional information on traffic position.
- In VIS.1 condition when transference point is distant from the controller working position, and the degree of aircraft similarity critical, the surveillance tool will help to confirm the hand over elements.
- In VIS.2 condition the surveillance tool will give accurate real time traffic situation awareness for both ground controllers without the need of pilot's reporting position

b) When ATCOs are located in the same tower:

The procedures previously described for 2 ATCOs in different towers could be applied. In addition, the procedures described for Coordination Ground ATCO/Airport ATCO could be applied too.

7.3.5.2 Co-ordination Ground Controller-Airport Controller

Co-ordination between sectors is regulated by ICAO in DOC 4444 section 10.4.5 and shall mainly rely on procedures applicable at ATC units.

Doc 4444 section 10.4.1 states the generic organisation of co-ordination and transfer of control. There is no co-ordination specific ruling in Doc 4444 section 8.10.2 (Use of SMR) but transfer of radar identification using Mode-S is covered by Doc 4444 section 8.6.3 c) and use of a discrete code by section 8.6.3 b).

ATC actions are as follows:

- Co-ordination and hand over when all traffic is in direct eyesight of both ground and airport (local) controller:
 1. Based on local regulation, the flight strip (paper or electronic) used by the ground controller for departing traffic is transferred to the airport (local) controller where or when deemed necessary.
 2. This flight strip should contain all information on the traffic including updates needed by tactical actions such like use of intersection take off Taxiway identification or Rapid Exit Taxiway (RET) identification.
 3. The receiving controller should verify visually that the contacting traffic is positioned on the right taxiway (Intersection or RET) before giving further clearance.
 4. Vice-versa for arrival traffic.
- Co-ordination and hand over when all traffic is not in direct eyesight of both ground and airport (local) controller:
 1. Based on local regulation, the flight strip used by the ground controller for departing traffic is transferred to the airport (local) controller where or when deemed necessary. Information on position is relayed from pilot's reports with the help of SMR if approved.
 2. (Vice-versa for arrival traffic)
 3. This flight strip should contain all information on the traffic including updates needed by tactical actions such like use of intersection take off identification or Rapid Exit Taxiway identification.

4. The receiving controller should verify with the pilot report that the contacting traffic is positioned on the right taxiway (Intersection or RET) before giving further clearance.

A-SMGCS Regulation

The A-SMGCS surveillance tool provides on a display an approved situation of identified aircraft/vehicles.

The A-SMGCS surveillance regulation will replace the SMR regulation.

- In VIS.1 and VIS.2 conditions the automated identification process will provide to both ground and airport controllers with the same traffic situation avoiding the need to request additional information on traffic position.
- In VIS.1 condition when runway entry or exit is distant from the controller working position, and the degree of aircraft similarity critical, the surveillance tool will help to confirm the hand over elements.
- In VIS.2 condition the surveillance tool will give accurate real time traffic situation awareness for both ground and aerodrome controller without the need of pilot's reporting position.
- Flight strips presentation: unambiguous and accurate information must be provided to all controllers as in VIS.3 and VIS.4 the need to reverse to procedural control will let them have flight strips as the main support for their task.

7.3.6 Taxiing on the Runway

For the seven procedures hereafter it is assumed that permanent obstacles will not obstruct the controller's view on the runway.

It should be first considered if the runway is a "non-active runway" or an "active runway" when it is used as a part of the taxi route.

Note: a closed runway is considered as a taxiway under the responsibility of the ground controller and taxiway procedures are in use.

Proposal for paragraph above:

A non-active runway which is being used as a taxiway is under the responsibility of the aerodrome controller or ground controller. On the non-active runway, taxi procedures are in use and applied with co-ordination between aerodrome and ground controllers.

In case of using an "active runway" the procedures will be under the responsibility of the aerodrome controller who will apply the procedures described below. These procedures apply equally to aircraft or vehicles.

The specific point of these procedures is that aircraft that could be at the origin of potential conflicts may be moving at high speed, giving only a short time for ATC reaction.

7.3.6.1 The full length of the runway is visible to the controller

ATC actions:

- ATC check that the position transmitted by the pilot/driver requesting to taxi on the runway is consistent with observed position and:

- Dependent on traffic information available (visual, procedural, or with the use of air radar surveillance display) of airborne conflicting ATC traffic allows, delays or denies the ATC clearance to enter on the runway. (ICAO Doc 4444 section 7.5.3.1.2)
- When the clearance is transferred to the pilot/driver, confirm visually the conformance to the ATC clearance
- Check when the runway is vacated and in doubt (e.g.; exit distant from the tower) request the pilot/driver to report runway vacated, or
- If the clearance to the flight crew was aiming to backtrack in order to take off, follow up the procedures with further ATC clearances.

7.3.6.2 The Full Length of the runway is not visible to the controller

ATC actions:

- ATC request the pilot/driver to report (or confirm) his position by using visual identifying marks (panels, painting marks, stop bars...etc).
- If an SMR is available and identification procedures carried out, verify that the position transmitted is coherent with the position observed on controller's display.
- Subject to information provided by other sources (visual, procedural, or with the use of air radar surveillance display) of airborne conflicting traffic allow, delay or deny the ATC clearance to enter on the runway. (ICAO Doc 4444 section 7.5.3.1.2)
- Request the pilot/driver to report when runway is vacated, or follow up ATC clearances when taxi on the runway is used to backtrack in order to take off.
- If an SMR is available, and subject that identification procedures have been carried out, verify that runway is vacated by the authorised aircraft/vehicle.

A-SMGCS Regulation

The A-SMGCS surveillance tool provides on a display an approved situation of identified aircraft/vehicles.

The A-SMGCS surveillance regulation will replace the SMR regulation.

Under all visibility conditions the surveillance of the runway will be improved by a continuous follow up of identified and labelled traffic. R/T exchanges will be reduced to a minimum (position reports will be on request).

It will help to anticipate ATC planning and by monitoring traffic commencing its take-off roll.

7.3.7 Line-Up Procedures

7.3.7.1 Line-up from the runway threshold

7.3.7.1.1 Runway threshold is visible to the controller

ATC actions:

- ATC check that the position transmitted by the flight crew requesting to line up on the runway is consistent with observed position and:
- Subject to information provided by other sources (visual, procedural, or with the use of air radar surveillance display) of airborne conflicting traffic allow, delay or deny the ATC clearance to enter on the runway. (ICAO Doc 4444 section 7.5.3.1.2).

7.3.7.1.2 Runway threshold is not visible to the controller

ATC actions:

- ATC request the pilot/driver to report (or confirm) his/her position by using visual marks (panels, painting marks, stop bars).
- If an SMR is available and identification procedures have been carried out, verify that the position transmitted is coherent with the position observed on display.
- Subject to his knowledge (procedural, or with the use of air radar surveillance display if allowed) of airborne conflicting traffic allow, delay or deny the ATC clearance to enter on the runway.

A-SMGCS Regulation

The A-SMGCS surveillance tool provides on a display an approved situation of identified aircraft/vehicles.

The A-SMGCS surveillance regulation will replace the SMR regulation.

Under VIS.2, VIS.3 and VIS.4 conditions, the A-SMGCS surveillance tool will provide the real position of the traffic (under VIS.1 conditions it will help to confirm traffic position if distant from the control tower).

It will help to anticipate ATC planning and instructions by seeing traffic starting to roll.

7.3.7.2 Line-up from intersection

The general conditions of application are described in DOC 7030 Part 3 section 2.0 “Intersection Take off”.

7.3.7.2.1 The intersection is visible to the controller

ATC action:

- If intersection take off is agreed by national or local ATC authorities the same procedure as line up from runway threshold (section 7.3.7.1.1) is applied.

7.3.7.2.2 Intersection is not visible to the controller

ATC action:

- If intersection take-off is agreed by national or local ATC authorities under that MET conditions, the same procedure as line up from threshold (section 7.3.7.1.2) is applied.

7.3.7.3 Conditional and multiple line-up

The general conditions of application are described in DOC 7030 Part 3 section 3.0 “Multiple line up on the same runway”.

The text is issued from previous studies that encompass multiple line-up from different points on the same runway (Doc 7030 Part 3 section 3.1.1).

7.3.7.3.1 From different intersection

Multiple line-up is defined as line up at different points on the same runway in DOC7030 Part 4. The appropriate authority shall establish a minimum visibility to allow that procedure. Those minima shall permit the controller and the pilot to continuously observe the position of the relevant aircraft on the manoeuvring area by visual reference. Conditions of applications shall rely on DOC7030 EUR Part3 section 3.1 and associated phraseology described in Part 3 section 3.2.

7.3.7.3.1.1 Intersection is Visible to the Controller

ATC action:

- ATC check that the position transmitted by the flight crews requesting to line up on the runway is what it is observed outside; and
- Subject to information provided by other sources (visual, procedural, or with the use of air radar surveillance display) of airborne conflicting traffic allow, delay or deny the ATC clearance to enter on the runway. (Doc 4444 section 7.5.3.1.2);
- When transmitting the line up clearance the aerodrome controller advise all flight crews of the respective position of others traffic involved in multiple line up;
- The aerodrome controller exercises a strong awareness on the flight crew read-back.

7.3.7.3.1.2 Intersection is not visible to the controller

ATC action(s): there are no current procedures that provide for this option (Doc 7030 Part 3 section 3.1.1 a).

A-SMGCS Regulation

The A-SMGCS surveillance tool provides on a display an approved situation of identified aircraft/vehicles.

The A-SMGCS surveillance regulation will replace the SMR regulation.

ATC will be allowed to use that procedure under VIS.2 conditions). Under VIS.3 and VIS.4 conditions this should not be applied, as pilots don't see each other.

Under VIS.2 conditions the A-SMGCS surveillance tool will provide an accurate and real time position of the different traffic waiting at different intersections (under VIS.1 conditions it will help to confirm traffic position if distant from the control tower).

It will help to anticipate ATC planning and instructions by seeing traffic starting to taxi.

Under VIS.3 and VIS.4 conditions, multiple line-up will not be performed.

Note: the A-SMGCS surveillance data will not override the need for the second pilot to see and identify the previous cleared traffic.

7.3.7.3.2 From the same intersection

Conditional line-up refers to the line-up of several aircraft from the same intersection. This procedure is not considered by the condition of application of multiple line-ups on the same runway (Doc 7030 section 3.1.1) which state that "*line up instructions may be issued to more than one aircraft at different points on the same runway*".

ANSPs which are using conditional line up from the same runway access point consider this procedure as an application of a conditional ATC clearance to sequenced departure traffic.

7.3.8 Take-Off Clearances

7.3.8.1 Take-off clearance from runway threshold

7.3.8.1.1 *The runway is visible to the controller*

ATC action: assuming that the conditions prescribed in Doc 444 section 7.6.7.8.4 are combined, after visual check of the runway, the aerodrome controller issues the take off clearance with the appropriate phraseology and monitors the pilot read back.

7.3.8.1.2 *The runway is not visible to the controller*

ATC action:

- The aerodrome controller has already instructed others traffic to report when runway is vacated;
- Assuming that the conditions prescribed in Doc 4444 section 7.8.4 are combined, the aerodrome controller issues the take off clearance using the prescribed phraseology and monitors the read-back, ensuring that it is correct;
- If an SMR is available, the controller can check that the runway is clear and it will help to anticipate ATC planning and instructions by monitoring traffic commencing its' take off roll.

A-SMGCS Regulation

The A-SMGCS surveillance tool provides on a display an approved situation of identified aircraft/vehicles.

The A-SMGCS surveillance regulation will replace the SMR regulation.

In all VIS conditions the A-SMGCS surveillance tool will increase the situation awareness of runway occupancy and thereby reduce the R/T workload by limiting the number of R/T exchanges with pilots.

7.3.8.2 Take-off clearance from intersection

7.3.8.2.1 *The intersection is visible to the controller*

ATC action:

- The aerodrome controller checks visually if the aircraft is lined up at the correct intersection and in case of multiple line ups from different intersections that it is the aircraft N°1 in the sequence (no traffic ahead)
- Transmit the take off clearance with the appropriate phraseology and monitor the pilot read back (Doc 7030 Part 3 section 2.0)

7.3.8.2.2 *The intersection is not visible to the controller*

If the procedure is agreed by the ATC authorities:

ATC action:

- The aerodrome controller should check, by asking the pilot to report that he is lined-up at the correct intersection giving the intersection identification
- If an SMR is available, the controller can check that the runway is clear and it will help to anticipate ATC planning and instructions by monitoring traffic commencing its' take-off roll
- Transmit the take off clearance with the appropriate phraseology and monitor the pilot read back (Doc 7030 Part 3 section 2.0)

A-SMGCS Regulation

The A-SMGCS surveillance tool provides on a controller's display an approved situation of identified aircraft/vehicles.

The A-SMGCS surveillance regulation will replace the SMR regulation.

In all visibility conditions the A-SMGCS surveillance tool will increase situation awareness on runway occupancy and reduce the R/T workload. The correct position (intersection number) can be verified on the controller's display.

7.3.9 Conditional Clearances

7.3.9.1 Preamble

Considering the Aerodrome control service, conditional clearances are not described as dedicated ATC procedures in the Doc 4444 chapter 7 but introduced in Chapter 12 as a specific use of phraseologies. ANT/APDSG recently conducted an extended discussion, for a proposed amendment to ICAO Doc 4444 on the subject of conditional clearances. In that proposal, the recommendation was that:

- a) The procedure be relocated to chapter 7, "procedures for aerodrome Control Service",
- b) A strengthening of the requirement for "unambiguous identification by the aircraft receiving a conditional clearance, of the aircraft or vehicle being the subject of the condition" was required;
- c) The APDSG envisaged that the visual identification of the aircraft might be reviewed in light of A-SMGCS techniques, but agreed to focus on current operations. As soon as detailed A-SMGCS procedure requirements and tools become available, action would be taken to address this issue.

The proposal has been forwarded to ICAO. At this time, there has been no finalisation to the process.

7.3.9.2 Conditional Clearance Existing Provisions

The current provisions relating to conditional phrases and clearances are that:

- 1) They shall not be used for movements affecting active runways except when the aircraft or vehicles concerned are seen by the appropriate controller and pilot;
- 2) In all cases, a conditional clearance shall be given in the following order and consist of:
 - Identification;
 - The condition;
 - The clearance; and
 - Brief reiteration of the condition.

7.3.9.3 A-SMGCS Aspects about Conditional Clearances

The main concern, for the efficient use of the procedure, is that the crew receiving the conditional clearance shall be able to unambiguously identify as early as possible the object of the condition. This is the flight crew ability to visually acquire the aircraft on final or departing ahead of him which give the possibility to anticipate by a short time figure his taxi to the line up position.

It is clear that the A-SMGCS surveillance data does not provide the flight crew with a better and anticipated view (visual recognition) of the incoming or departing aircraft, but it will give the opportunity to lift the constraint of "visual observation" imposed on the controller by ICAO Doc 4444 section 7.1.1.2

A-SMGCS Regulation

A-SMGCS provides on a controller's display an approved situation of identified aircraft/vehicles.

A-SMGCS regulation will replace SMR regulation.

In all visibility conditions A-SMGCS will increase the situation awareness on runway occupancy and reduce the R/T workload as the controller will use the data coming from the surveillance tool when there is a lack of outside visual references.

In VIS.3 and VIS.4 conditions, conditional clearances will not be performed.

A-SMGCS will provide the possibility to use conditional clearances procedures under VIS.2 conditions.

7.3.10 Landing Clearance

7.3.10.1 The Runway is Visible to the Controller

ATC action:

- Assuming that the conditions prescribed in Doc 4444 section 7.9.3 are combined, after a visual check of the runway, transmit the landing clearance with the appropriate phraseology;

7.3.10.2 The Runway is not visible to the Controller

ATC action:

- Assuming that the conditions prescribed in Doc 4444 section 7.9.3 are combined;
- If an SMR is available, the controller can check that the runway is clear and it will help to anticipate ATC planning and instructions by monitoring traffic on the runway;
- Transmit the landing clearance with the appropriate phraseology;

A-SMGCS Regulation

The A-SMGCS surveillance tool provides on a controller's display an approved situation of identified aircraft/vehicles.

The A-SMGCS surveillance regulation will replace the SMR regulation.

In all visibility conditions the A-SMGCS surveillance tool will increase the situation awareness of runway occupancy and reduce the R/T workload.

7.3.11 Summary

If an airport is equipped with an A-SMGCS:

1. The "new procedures" used on the movement area will not change in VIS.1 and VIS.2 conditions from the present procedures (pre-departure, push back or towed out, taxi clearance and control of taxiway intersection, taxiing on runway procedures) in the sense that the pilot will remain in charge of visual "separation". The approved surveillance tool given to the controller will increase his/her situational awareness and will decrease his/her R/T exchanges workload in VIS.2 conditions but the present sharing of responsibility will remain the same.
2. On the manoeuvring area, the approved surveillance tool given to the controller will improve his/her situational awareness and will reduce his/her workload in VIS.2 conditions, but the present sharing of responsibility will remain the same.
3. There is a requirement to perform further study in VIS.3 conditions to establish additional prescribed collision avoidance procedures, and appropriate use of the HMI. Otherwise the procedural reporting procedures as used today could be used when a conflict is detected,

using the surveillance tool to confirm or release the instruction, in that case with a reduced capacity, but within a reduced R/T environment.

4. There is a requirement for the presence in VIS.4 conditions of a guidance tool, before establishing the surveillance standards rules.
5. On the runway or entering the runway (line-up, multiple line-up, conditional clearance, take off and landing procedures):
 - There will be a reduction of R/T workload,
 - The approved surveillance tool will increase the situational awareness of the controller by giving him/her a real time identified traffic display (for these procedures “separation” is provided by other means) in all visibility conditions.
 - For all conditional procedures where the pilot is involved the gain in low visibility should be studied further.

All figures used for visibility thresholds should be carefully studied in order to reduce them to a safe minimum. In determining the visibility threshold, due account should be taken on figures contained in existing documents.

7.4 Control Procedures associated to the Safety Net use

Note: The following procedures proposals in the section below are linked to runway/restricted area incursions. The need to address in EMMA conflict detection on taxiways, apron/stand/gate (and some RWY conflicts) shall be assessed and described by ANSPs. These will be refined during EMMA2 project.

7.4.1 Existing Safety Net and Warning Tools

A study is performed in the following sections about already existing safety nets (STCA, MSAW, and TCAS) and their procedures as detailed in Doc 4444. A comparison on how alerts are provided and used is made, in relation with the existing A-SMGCS requirements and specification (i.e. Pro & Con) in order to set up RWY incursion “warning procedures”.

Information and procedures described are taken from ICAO 4444 document (chapter 15).

7.4.1.1 Short Term Conflict Alert (STCA)

Existing procedures are not A-SMGCS procedures. The generation of short term conflict alerts is a function of an ATC radar data processing system. The objective of the STCA function is to assist the controller in maintaining separation between controlled flights by generating, in a timely manner, an alert of a potential infringement of separation minima.

In the STCA function, if the radar-derived current separation will decrease to less than the defined applicable separation minima within a specified time period, an acoustic and/or visual alert will be generated to the radar controller concerned.

Local instructions concerning use of the STCA function shall specify, *inter alia*:

- a) The types of flight which are eligible for generation of STCA;
- b) The sectors or areas of airspace within which the STCA function is implemented;
- c) The method of displaying the STCA to the controller;
- d) The parameters for generation of alerts as well as alert warning time;
- e) Conditions under which the STCA function may be inhibited for individual radar tracks;
and
- f) Procedures applicable in respect of flights for which STCA has been inhibited.

In the event an STCA is generated in respect of controlled flights, the controller shall without delay take action to ensure that the applicable separation minimum will not be infringed.

Following the generation of an STCA, controllers should be required to complete an air traffic incident report only in the event that a separation minimum was infringed.

The appropriate ATS authority should retain electronic records of all STCAs generated.

When comparing STCA with A-SMGCS safety net:

- **Pro:** The A-SMGCS safety net is a (very) short term conflict alert subject to the generic SCTA definition “*to assist the controller to maintain separation*” and as such, a function of the ATC Radar Data Processing System. The A-SMGCS safety net is intended to monitor for proximity, current and predicted trajectories derived from the Mode-S, A and C aircraft transponder capability. If the distance (time) is predicted to be less than the standard minima within a specified time period, an acoustic and/or visual alert will be generated.
- **Con:** The A-SMGCS safety net will be able to provide alert information when an aircraft/vehicle is entering a restricted area (e.g. a closed taxiway). This is performed for flying aircraft by an APW (Area Proximity Warning), not by a STCA.

7.4.1.2 Minimum Safe Altitude Warning (MSAW) Procedures

Existing procedures are not A-SMGCS procedures. The generation of minimum safe altitude warnings is a function of an ATC radar data processing system. The objective of the MSAW function is to assist in the prevention of controlled flight into terrain accidents by generating, in a timely manner, a warning of the possible infringement of a minimum safe altitude.

When comparing MSAW with A-SMGCS Safety Net:

- **Pro:** The A-SMGCS safety net is set up to assist the controller to avoid conflict which is the case for MSAW (in case of CFIT). It monitors for proximity, current and predicted trajectories derived from the Mode-S, A and C aircraft transponder capability.
- **Con:** Despite that MSAW is providing only one warning in case of risk of CFIT there are two different procedures for the controller receiving an alert subject to the level of responsibility linked to the navigation process at the warning time:
 - a) On a published trajectory, the alert is transferred to the crew with a warning to check his level, based on “information” service.
 - b) In case of radar vectoring, it is up to the controller to send immediately an instruction to climb to a safe altitude or to give a new heading to avoid terrain.

7.4.1.3 Procedures in regard to aircraft equipped with ACAS

Existing procedures are not A-SMGCS procedures. ACAS is an aircraft system based on secondary surveillance radar (SSR) transponder signals. It operates independently of ground-based equipment to provide advice to the pilot on potential conflicting aircraft that are equipped with SSR transponders.

When a pilot reports a manoeuvre induced by an ACAS resolution advisory (RA), the controller shall not attempt to modify the aircraft flight path until the pilot reports returning to the terms of the current air traffic control instruction or clearance but shall provide traffic information as appropriate.

Note 1: — Operating procedures for use of ACAS are contained in PANS-OPS (Doc 8168), Volume I, Part VIII, Chapter 3.

Note 2: — the phraseology to be used by controllers and pilots is contained in Doc 4444 Chapter 12.

When comparing ACAS with A-SMGCS safety net:

- **Pro:** ACAS gives warnings to the pilot only (not to ATC). Similar to the A-SMGCS safety net, it provides two levels of warning:
 - a) TA, which is only a traffic information presence with no potential conflict foreseen.
 - b) RA, which is an order to execute an action without delays. This action is derived from a pre-set number of limited generic actions (according to the configuration of the conflict).
- **Con:** The TA information does not preclude to any kind of conflict. RA, (which can be compared to A-SMGCS “Alarm”) produces an automated conflict resolution scheme that has to be executed by the pilot.

7.4.2 General principles for ground and airborne alerting

During a flight the pilot is in charge of the conduct of his/her own aircraft and the controller is responsible for managing safely and efficiently the entire traffic context.

When considering to whom and when to give an alert, we have to keep in mind this general principle and the time needed for the event before that the last chance to avoid an accident is the reaction of the pilot.

Until that point the alert should be given only to the controller who is the only one to know the whole situation and so in the best position to resolve it.

The when and how giving the alert to ATCOs and pilots is also influenced by where the a/c is and in which phase of the flight.

The easiest way to alert directly and automatically vehicles drivers could be when they entered protected areas such as active runways or sensitive areas.

7.4.3 Possible Control Procedures with RIMS (Runway Incursion Monitoring System)

The A-SMGCS Safety Net provides the controller with two types of alert, named ‘Information’ & ‘Alarm’.

- **INFORMATION:** When receiving an “Information Alert”, a potential dangerous situation may occur. The controller will use his skill and backgrounds to decide if, with remaining possible actions, the situation can be saved without using a too restrictive procedure (e.g. go around). If successful, there will be no Alarm and if not successful the Alarm will be activated and be presented on the surveillance display.
- **ALARM:** When receiving an “Alarm”, it is said that a critical situation is developing and that an immediate action should be performed.

ICAO A-SMGCS manual (9830) (section 3.4.5.7) states that “every aerodrome has site-specific parameters and situations to be addressed”. The following list provides some of the possible conflict alert scenarios that should be both predictable and detectable by the A-SMGCS.

a) Runway conflicts

- 1) Aircraft arriving to, or departing aircraft on, a closed runway. *-(implementation step 1⁷)*
- 2) Arriving or departing aircraft with traffic on the runway (including aircraft beyond the runway holding position). *-(implementation step 1)*
- 3) Arriving or departing aircraft with moving traffic to or on a converging or intersecting runway; *-(implementation step 1)*
- 4) Arriving or departing aircraft with opposite direction arrival to the runway; *-(implementation step 1)*
- 5) Arriving or departing aircraft with traffic crossing the runway; *-(implementation step 1)*
- 6) Arriving or departing aircraft with taxiing traffic approaching the runway (predicted to cross the runway holding position); *-(implementation step 1)*
- 7) Arriving aircraft exiting runway at high speed with converging taxiway traffic; *-(implementation step 2)*.
- 8) Arriving aircraft with traffic in the sensitive area (when protected); *-(implementation step 1)*
- 9) Aircraft exiting the runway at unintended or non-approved locations; *-(implementation step 1)*
- 10) Unauthorised traffic approaching the runway; *-(implementation step 1)*
- 11) Unidentified traffic approaching the runway; *-(implementation step 1)*

b) Taxiway conflicts

- 1) Aircraft on a closed taxiway; *-(implementation step 1)*
- 2) Aircraft approaching stationary traffic; *-(implementation step 2)*
- 3) Aircraft overtaking same direction traffic; *-(implementation step 2)*
- 4) Aircraft with opposite direction traffic; *-(implementation step 2)*
- 5) Aircraft approaching taxiway intersections with converging traffic; *(implementation step 2)*
- 6) Aircraft taxiing with excessive speed; *-(implementation step 1)*
- 7) Aircraft exiting the taxiway at unintended or non approved locations; *(implementation step 2)*
- 8) Unauthorized traffic on the taxiways; *-(implementation step 2)*
- 9) Unidentified traffic on the taxiways; *(implementation step 2)*
- 10) Crossing a lift stop bar. *-(implementation step 1)*

c) Apron/stand/gate conflicts

- 1) Aircraft movement with conflicting traffic; *-(implementation step 4)*
- 2) Aircraft movement with conflicting stationary traffic; *-(implementation step 4)*
- 3) Aircraft exiting the apron/stand/gate area at unintended or non-approved locations; *-(implementation step 4)*
- 4) Unidentified traffic in the apron/stand/gate area. *-(implementation step 4)*

The D131u OSED-update document (section 3.1.2.2) has identified four logical steps regarding the ATCO control services, e.g.

- **C1:** conflict and incursion detection for infringements into restricted areas, runways by either aircraft or vehicles (section 7.6.3);
- **C2:** taxiway conflict/incursion detection and alerting (section 7.6.4);
- **C3:** plan deviation detection (section 7.6.5) and support to ground clearance and ATCO coordination (section 7.6.6);
- **C4:** apron / stand / gate conflict detection procedures (section 7.6.7).

⁷ See OSED Document, section 3.1.2.2 (Control Service, Steps for the service)

7.4.4 RWYs / Protected areas conflict detection rules (C1)

7.4.4.1 Aircraft arriving to, or departing on a closed runway

- aircraft on runway protection area surface: will trigger an ‘alarm’ coding; (remark: this coding is different from the one of “level requirements” document, to be more protective for the persons who could be working on the runway; so this case and the following one could be resumed in one: “an aircraft is in the runway protection area => Alarm)

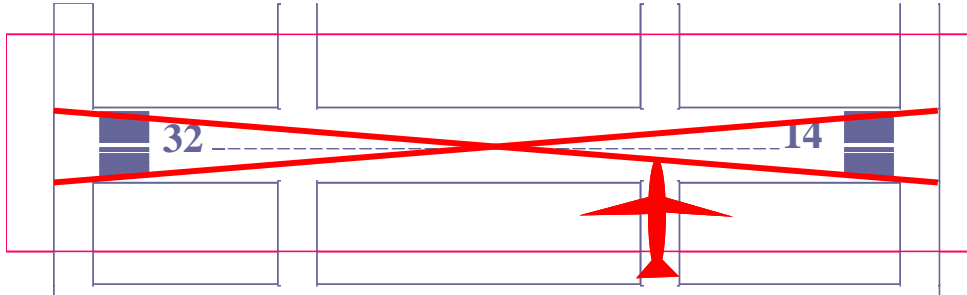

- Aircraft lining-up or taking-off: will trigger an alarm coding.

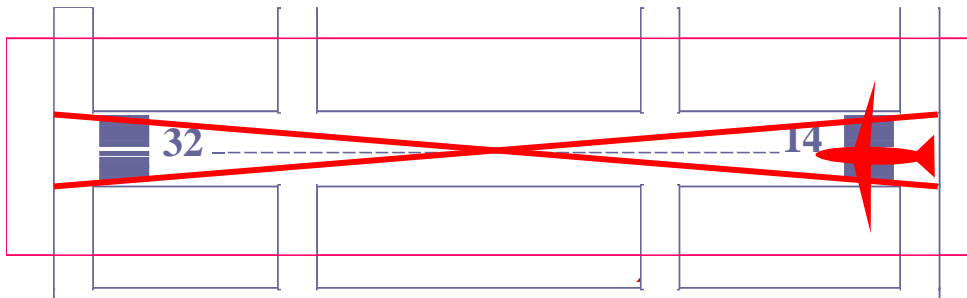

- arriving aircraft (< T1 from threshold): will trigger an ‘information’ coding
- arriving aircraft (< T2 from threshold): will trigger an ‘alarm’ coding

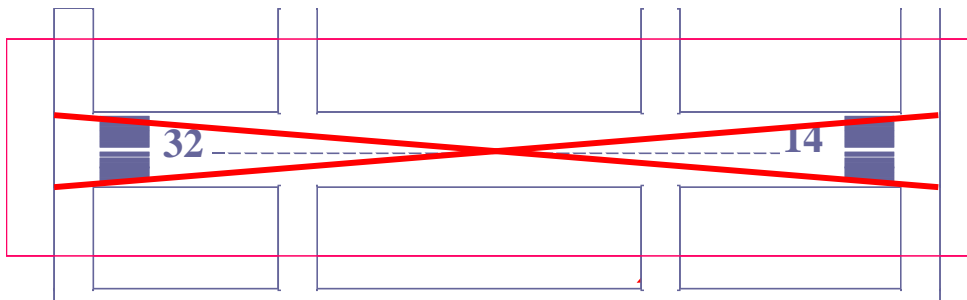

Note: in [Eurocontrol-D4] document, T1 and T2 thresholds are defined as follows:

- 1) In non-LVP conditions: T1=30''; T2=15''
- 2) In LVP conditions: T1=45''; T2=30''

7.4.4.2 Arriving or departing aircraft with opposite direction to the runway in use

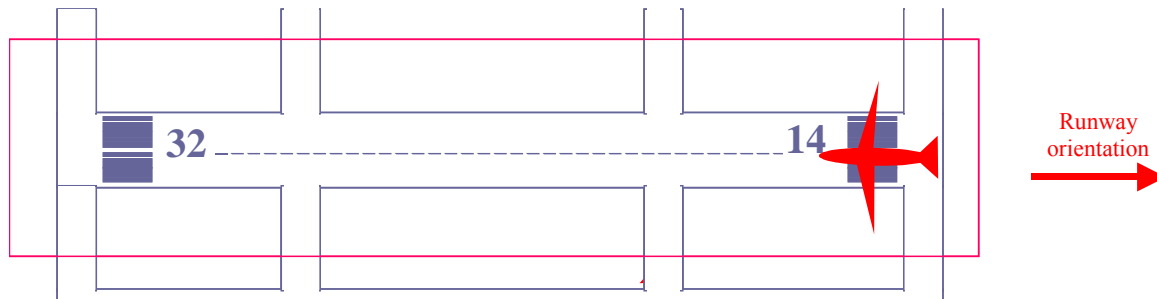

Aircraft proceeding in the wrong direction will trigger an "information" alert:

- when the aircraft is lining-up or taking off,
- when the arriving aircraft <T1 from the threshold

If there is an aircraft/vehicle on the runway or arriving on the runway, the rules managing the conflicts/infringements involving an aircraft and another aircraft/vehicle will apply.

7.4.4.3 Arriving aircraft with traffic in the runway protection area

- Preceding traffic is a vehicle, a crossing aircraft or an unknown aircraft/vehicle

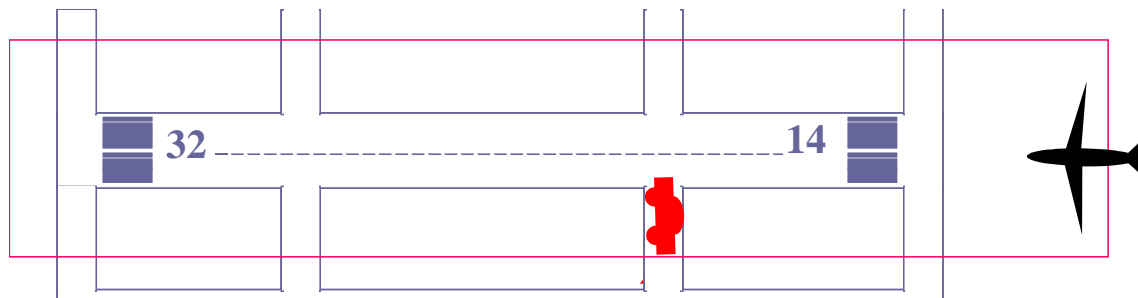

When a preceding vehicle, crossing aircraft or unknown aircraft/vehicle is in the runway protection area:

- 1) If the arriving aircraft < T1 from the threshold, then an information coding will be triggered.
- 2) If the arriving aircraft < T2 from the threshold, then an alarm coding will be triggered.

- Preceding traffic is an arriving aircraft

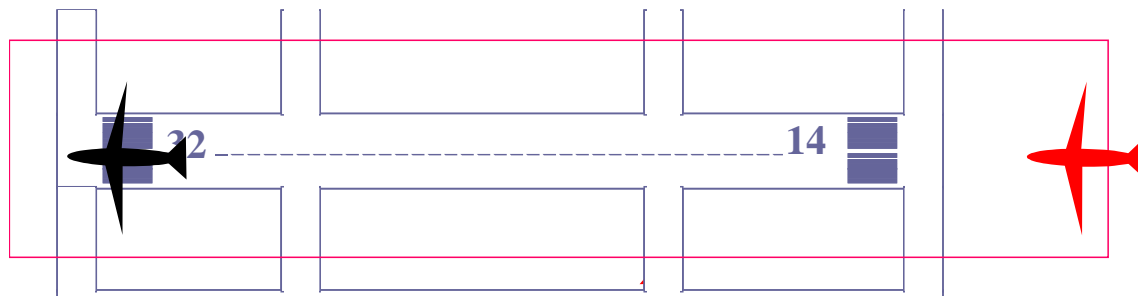

- a) If reduced spacing procedures are not enforced:

If there is a preceding arriving aircraft which has not cleared the runway protection area volume (*taking into account the aircraft which would be over the runway but not on the surface* - [ICAO-4444 7.9.1]), and

- 1) The arriving aircraft $< T_1$ from the threshold, then an information coding will be triggered.
- 2) The arriving aircraft $< T_2$ from the threshold, then an alarm coding will be triggered.

b) If reduced spacing procedures are enforced:

If reduced spacing procedures are enforced the following amendment shall be made according to the distance (D) between both aircraft:

- 1) If the arriving aircraft $< T_1$ and $> T_2$ from threshold, then an information coding will be triggered;
- 2) If the arriving aircraft $< T_2$ from threshold, departing aircraft on runway protection area and (D) $>2500m$, then an information coding will be triggered;
- 3) If the arriving aircraft $< T_2$ from threshold, departing aircraft on runway protection area and (D) $< 2500m$, then an alarm coding will be triggered;

- Preceding traffic is a departing aircraft

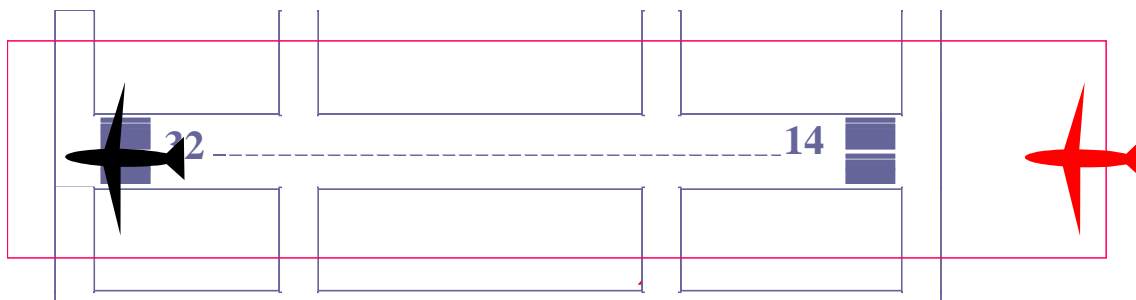

a) If reduced spacing procedures are not enforced:

If there is a preceding departing aircraft which has not cleared the runway protection area volume ([ICAO-4444 7.9.1]), and

- 1) If the arriving aircraft $< T_1$ from the threshold, then an information coding will be triggered.
- 2) The arriving aircraft $< T_2$ from the threshold, then an alarm coding will be triggered.

b) If reduced spacing procedures are enforced:

If reduced spacing procedures are enforced the following amendment shall be made according to the distance (D) between both aircraft:

- 1) If the arriving aircraft $< T_2$ from threshold and (D) $>2500m$, then an information coding will be triggered;
- 2) If the arriving aircraft $< T_2$ from threshold, $2000m < (D) < 2500m$ and departing aircraft has taken off, then an information coding will be triggered;
- 3) The arriving aircraft $< T_2$ from threshold, $2000m < (D) < 2500m$ and departing aircraft has not taken off, then an alarm coding will be triggered;
- 4) The arriving aircraft $< T_2$ from threshold and (D) $< 2000m$, then an alarm coding will be triggered;

7.4.4.4 Departing aircraft with traffic in the runway protection area

- Preceding traffic is a vehicle, an arriving or crossing aircraft, or an unknown aircraft/vehicle

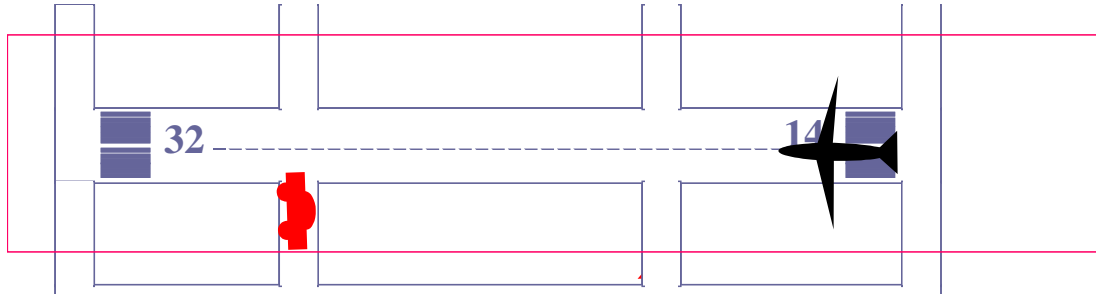

If an arriving aircraft, or crossing aircraft, or unknown traffic is on the runway protection area surface and not behind a departing aircraft:

- 1) If the departing aircraft is stopped (0 knot), then no information coding will be triggered;
- 2) If the departing aircraft is not taking off (speed < 50 knots) then an information coding will be triggered;
- 3) If the departing aircraft is taking off (speed > 50 knots), then an alarm coding will be triggered.

Remark: This rule could be cancelled for crossing aircraft only if there are several (to avoid nuisance alerts)

- Preceding or following traffic is a lining up aircraft

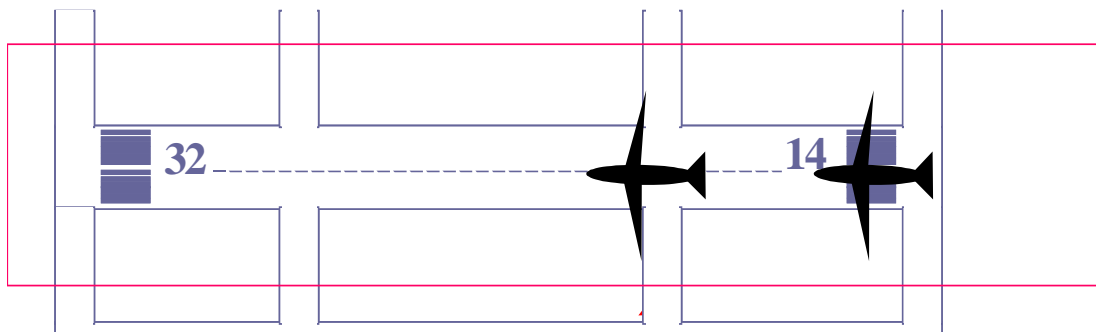

- a) If multiple line up procedures are not enforced;

If two departing aircraft are lining up on the runway from different taxiways, then an information coding will be triggered

- b) If multiple line up procedures are enforced;

If two departing aircraft are lining up on the runway from different taxiways, no alert coding shall be triggered

- Preceding or following traffic is taking off

- a) If reduced spacing procedures are not enforced:

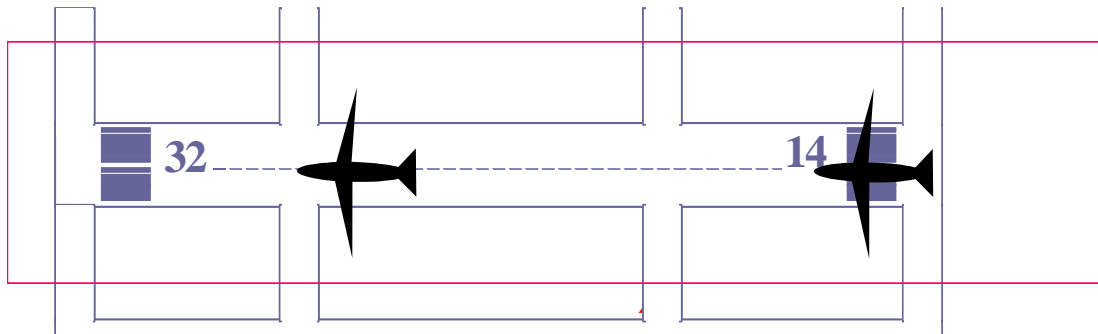

When preceding traffic is taking off and still in the Runway Protection Area Volume (on or over the runway protection area surface), and if the following departing aircraft is taking off (speed > 50 knots), then an alarm coding will be triggered.

b) If reduced spacing procedures are enforced:

1) If reduced spacing procedures are enforced the following amendment shall be made according to the distance (D) between both aircraft:

When preceding traffic is taking off and still in the Runway Protection Area Volume (on or over the runway protection area surface):

- If the following departing aircraft is taking off, the preceding aircraft is still ON the runway and $D > 2500\text{m}$, then an information coding will be triggered;
- If the arriving aircraft < T2 from threshold, arriving aircraft on or above runway protection area - $(D) < 2500\text{m}$, then an alarm coding will be triggered;

2) If reduced spacing procedures are enforced the following rules shall be applied according to the distance (D) between both aircraft when the following aircraft is taking off (speed > 50 knots):

- If the preceding departing aircraft is ON runway protection area surface and $(D) > 2500\text{m}$, then an information coding will be triggered;
- If the preceding departing aircraft is ON runway protection area surface and $(D) < 2500\text{m}$, then an alarm coding will be triggered;
- If the preceding departing aircraft is above runway protection area surface and $2000\text{m} < (D) < 2500\text{m}$, then an information coding will be triggered;
- If the preceding departing aircraft is above runway protection area surface and $(D) < 2000\text{m}$, then an alarm coding will be triggered;

- Arriving or departing aircraft with moving traffic to/on converging or intersecting runways

Some rules for detecting conflict in intersecting runways have been defined in [Eurocontrol-D4], where two different intersecting runways time to threshold (IRT1 and IRT2) have been defined:

- Long final: aircraft is on final between IRT1 and IRT2;
- Short final: aircraft is on final between IRT2 and threshold over-flight.

Five phases of flight have been considered:

- The reference aircraft is a lining up aircraft;
- The reference aircraft is a taking off (Speed > 50 kts) aircraft;
- The reference aircraft is an arriving aircraft on long final (< IRT1)

- The reference aircraft is an arriving aircraft on short final (<IRT2)
- The reference aircraft is landing

The following table summarises possible cases with departing aircraft with moving traffic to/on converging or intersecting runways:

Reference a/c	Conflicting a/c	'Information'	'Alarm'
Lining up a/c	an a/c is lined up on the other runway	X	
	an a/c is taking off on the other runway	X	
	an a/c is landing on the other runway	X	
	an a/c is arriving on short final (<IRT2) on the other runway	X	
Taking off a/c	An a/c is taking off on the other runway + converging		X
	An a/c is landing + converging		X
Landing	An aircraft is landing		X
Arriving a/c on long final (< IRT1)	an a/c is arriving on long final (< IRT1) on the other runway	X	
	an a/c is arriving on short final (< IRT2) on the other runway		X
	an aircraft is landing on the other runway + converging	X	
	an aircraft is taking off on the other runway + converging	X	
Arriving a/c on short final (< IRT2)	an a/c is arriving on short final (< IRT2) on the other runway		X
	an aircraft is landing on the other runway + converging		X
	an aircraft is taking off on the other runway + converging		X

7.4.4.5 Arriving or departing aircraft with taxiing aircraft/vehicle approaching the runway (predicted to cross the runway-holding position);

The trajectory prediction system shall predict the incursion of a vehicle/aircraft with an anticipation time taking into account:

- The time for the controller to acknowledge the alert,
- The time for the controller to send instruction to the pilot/vehicle driver (of the aircraft/vehicle or of the departing/arriving aircraft)
- The time for the pilot/vehicle driver to comply with this instruction.

The value of this anticipation time shall not be a source of false alerts. If these conditions are fulfilled, the following rules will be applied:

If the vehicle/aircraft is predicted to cross the holding point in front of:

- a taking off (speed > 50 knots) aircraft, then an alarm coding will be triggered;
- an arriving aircraft < T1 and > T2 from threshold, then an information coding will be triggered;
- an arriving aircraft < T2 from threshold, then an alarm coding will be triggered;

7.4.4.6 Arriving aircraft with traffic in protected areas

Protected areas and their associated protections used to detect incursions should be defined locally with respect to each airport particularity and to meteorological conditions.

- If an aircraft or vehicle enters a protected area, then an alarm coding will be triggered on the aircraft/vehicle.
- When an arriving aircraft <T1 from the threshold, the alarm coding will also be triggered on the arriving aircraft.
- If precision take-off procedures using the ILS are used, and an aircraft is lining up or taking off, then the alarm coding will also be triggered on the departing aircraft

7.4.4.7 Aircraft exiting the runway at unintended⁸ or non approved⁹ locations

A controller is not allowed to force a pilot to use a pre-defined runway exit. However, some runway exits may be closed: in that case, the "aircraft on a closed taxiway" rule will be applied.

7.4.4.8 Unidentified traffic entering the runway

If an unidentified traffic enters the runway, an information coding will be triggered.

7.4.4.9 Unauthorized traffic entering the runway

If an unauthorized traffic enters the runway, an information coding will be triggered.

7.4.5 Taxiways conflict detection procedures (C2)

As it is described in ICAO ANNEX 11 document, Chapter 2, paragraph 2.2, the general objectives of air traffic services is to prevent collisions. Application of that task shall be provided, except the others, to all aerodrome traffic at controlled aerodromes (Chapter 3, paragraph 3.1). Aerodrome traffic is defined as “all traffic on the manoeuvring area of an aerodrome and all aircraft flying in the vicinity of the aerodrome” (Chapter 1, Definitions). In aerodrome control it shall be understood as:

- Preventing collisions between aircraft in the air (ARR versus ARR, DEP versus DEP, ARR/DEP versus air traffic on aerodrome traffic circuit)
- Preventing collisions between aircraft on the manoeuvring area (RWY, HELI, TWY) (ARR versus ARR, ARR versus DEP, DEP versus DEP, re-taxiing aircraft versus all other aircraft;
- Preventing collisions between aircraft on the manoeuvring area and ground vehicles on the manoeuvring area (ARR versus vehicle, DEP versus vehicle, re-taxiing aircraft versus vehicle); note: “traffic” means both aircraft when using own trust for motion and ground vehicles (including towed aircraft).
- Preventing collisions between aircraft on the manoeuvring area and obstructions there. Note: obstructions on the manoeuvring area can be closures of unavailable parts of runways, heliports and taxiways.
- Provision of advises and information useful for the safe and efficient conduct of flights.

Note: the word “flight“ is used separately without “vehicles“ because in the process loop the aircraft of interest is dominant object from which all other subjects have to be separated (aircraft in all phases of the flight, vehicles and obstacles).

Preventing of collisions is done through the issuance of ATC clearances and traffic information. In conditions of aerodrome control it means to separate ARR/ARR, ARR/DEP, DEP/DEP using applied standard longitudinal separation minima valid in the air part as well as RWY part of the control

⁸ An unintended location is any runway exit location different from that the ATCo authorized

⁹ A non-approved location is any runway exit location non-authorized by the ATCo.

process loop. Such separation minima are based on the definition of THR of the RWY and on the definition of the edge of the RWY as the reference points to which the spacing distance or time is measured, vortex category of aircraft pairs involved, meteorological conditions, surface conditions and visibility factor from tower cab.

Separation minima between aircraft on the ground (manoeuvring area) are not generally defined. Therefore 'stop and go ATC clearance' and 'give a way ATC clearance' in combination with information about conflicting traffic passed in relevant format and sufficient time is used. In conditions of insufficient visibility, separation method of 'one frame on one TWY segment only' shall be applied.

Some ANS providers define minimum longitudinal distance in determined meteorological conditions. As an example, ANS Czech Republic is using parameter RVR TDZ RWY24 400 m or less and a system of TWY stop bars enabling/disabling further taxiing, relative distance of aircraft pairs is monitored by the controller using A-SMGCS surveillance where no stop bars are built up. In further development of A-SMGCS functionality, system of virtual stop bars should exist. This object oriented mechanism should enable the controller to allocate those guards to any required position on customer level as one of HMI function. When RPS representing target on A-SMGCS screen hits the guard, the controller would issue command to stop. This procedure should not harm the capacity of the aerodrome in VIS.3 conditions.

Further useful functionality seems to be a tool indicating:

- Cleared routing deviation,
- potential conflict with other traffic on same, opposite or crossing taxi routes,
- Potential conflict with closed parts of TWY system;

This functionality requires manual input of cleared routing from controllers. Useful result requires either advanced tracking and prediction logic or logical nod-to-nod network as a pre-requisite.

The following conflicts have been taken into account:

7.4.5.1 Arriving aircraft exiting runway at high speed with converging taxiway traffic:

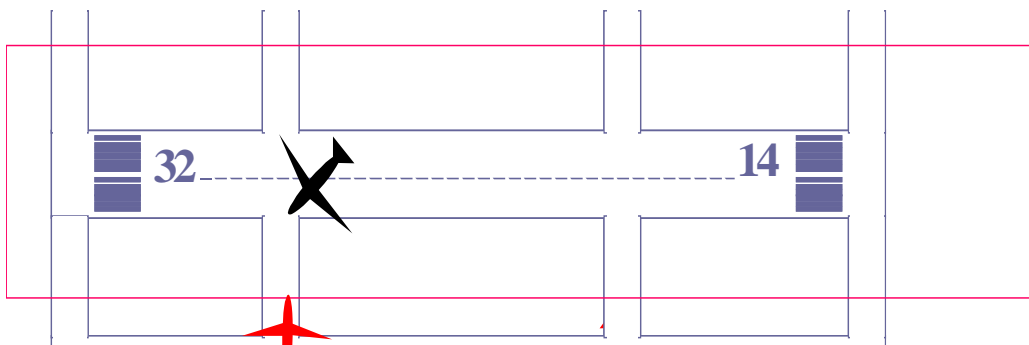

Stating first that:

- An aircraft vacating the runway on the wrong intersection will trigger an information coding;

- An aircraft/vehicle taxiing towards the runway and taking a wrong intersection will trigger an information coding.

If both traffic are cleared or are erroneously converging to the same intersection then an alarm will be triggered when the established rectangular areas around the targets will intersect each other; the dimension of this rectangle will consider the reported target speed in order to give reasonable time for reaction.

7.4.5.2 Aircraft on a restricted area

An alert will be triggered whenever an aircraft is approaching /entering a pre-defined restricted area which comprises any portion of the manoeuvring/movement area closed or restricted to aircraft; it may even include the ILS critical /sensitive area or one-way taxiways.

According to the possible danger of the situation, the Safety Net will provide an information coding or an alarm (this has to be agreed locally).

Even the procedures in force at the airport may determine the type of alert; e.g. during LVOs the sensitive area becomes restricted for all traffic, thus an alarm is needed.

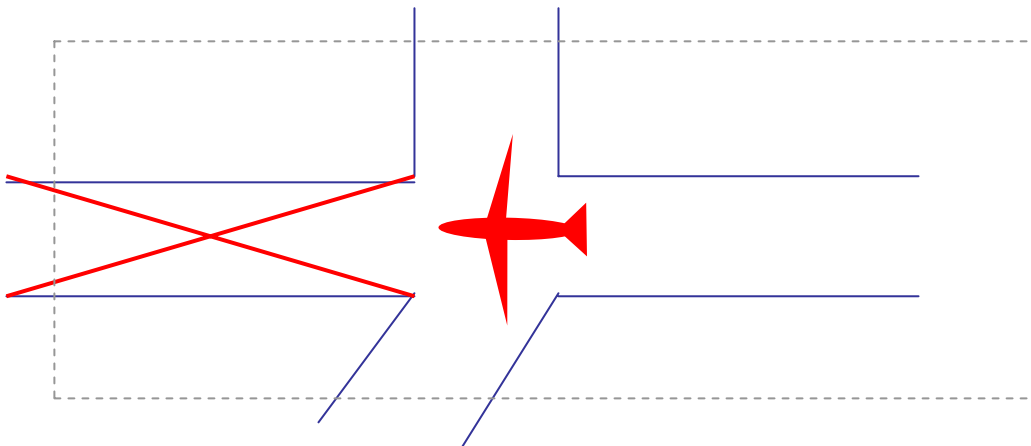

7.4.5.3 Aircraft approaching stationary traffic

Alerts on taxiways are generated to minimise the risk of collision of an aircraft with other traffic; an alarm will trigger when the established rectangular protection areas around the targets are intersecting each other; the dimension of this rectangle will consider the reported target speed, in order to give reasonable time for reaction, and the aircraft vortex category of preceding traffic.

In order to reduce to the minimum any *nuisance alerts* the criteria need to be carefully configured.

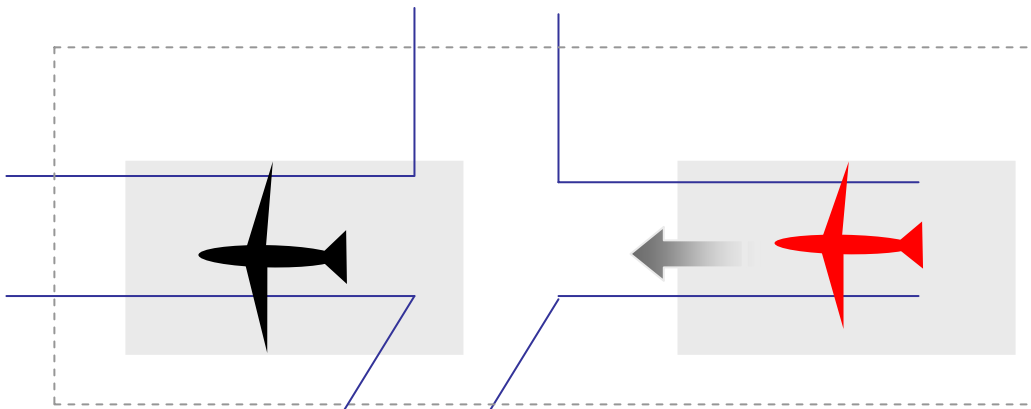

7.4.5.4 Aircraft overtaking same direction traffic

These examples may be considered:

- 1) Aircraft overtaking another aircraft on a taxiway not wide enough for the aircraft to pass each other;
- 2) Aircraft overtaking another aircraft on a taxiway wide enough for the aircraft to pass each other;
- 3) The manoeuvre has been cleared by the controller;
- 4) The manoeuvre has not been cleared by the controller.

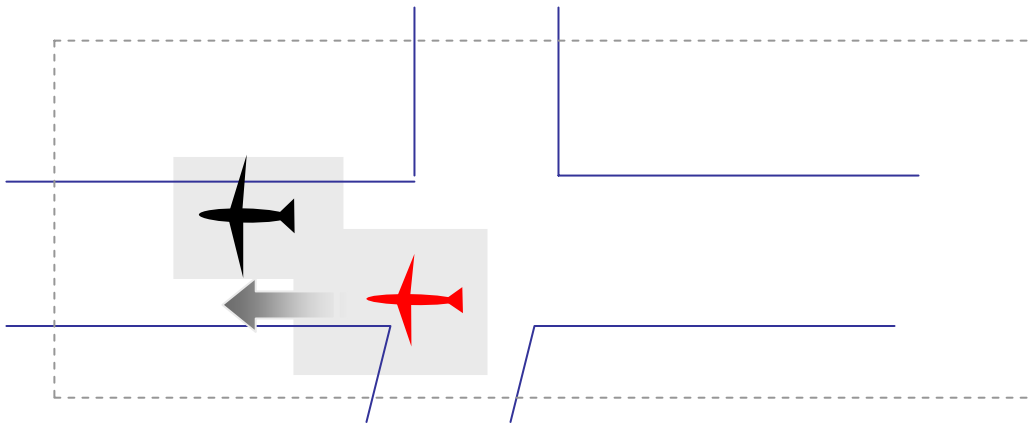

An alarm will be triggered in 1) and 2) cases (in case 2 if not cleared by the controller).

7.4.5.5 Aircraft with opposite direction traffic

Case 1: a/c 1 and a/c 2 cleared taxi routes are opposite

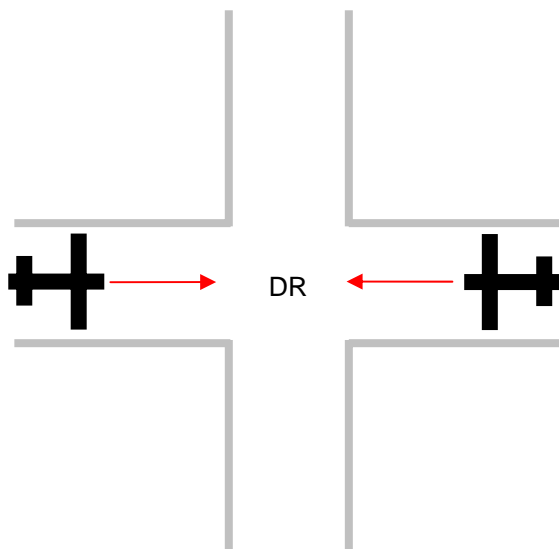

Pre-requisites

	a/c 1	a/c 2
Cleared route input	required	required
Positional data	required	required
Velocity data	not required	not required
Alert T1 ca 15 sec to DR		
T2 not used		

Priority

- DEP prior to ARR for deviating solution
- DEP No1 prior to DEP No 2 according to DMAN sequencing criteria for deviating solution

Case 2: a/c 1 and a/c 2 cleared taxi routes are opposite, but one A/C will deviate prior DR

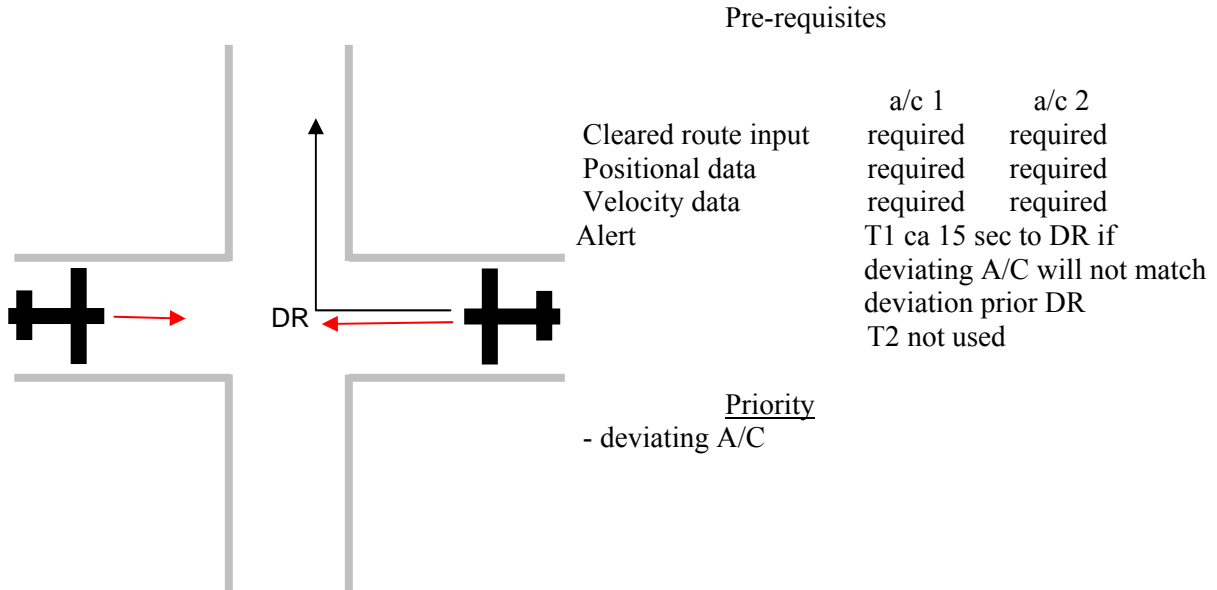

7.4.5.6 Aircraft approaching taxiway intersections with converging traffic;

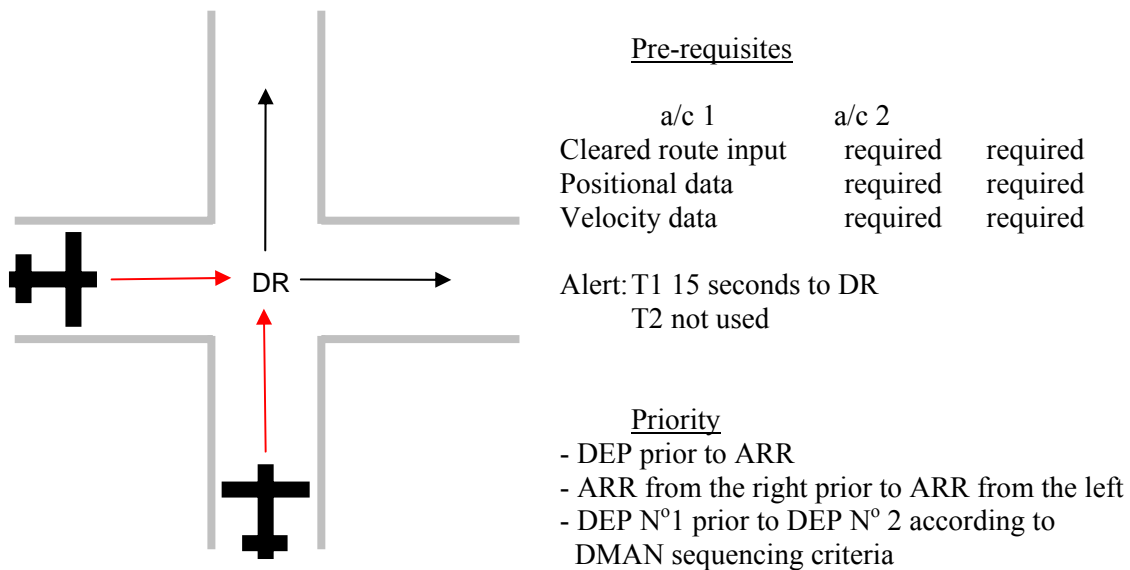

7.4.5.7 Aircraft taxiing with excessive speed;

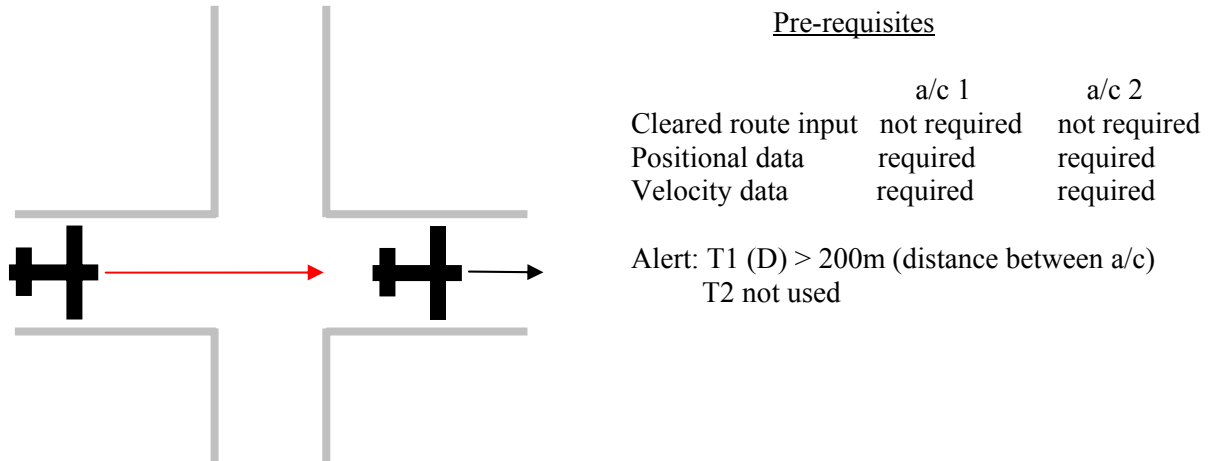

7.4.5.8 Aircraft exiting the taxiway at unintended or non-approved locations

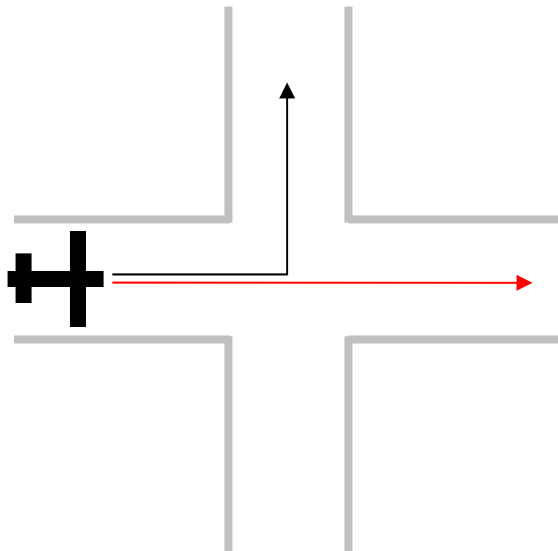

Pre-requisites:

Cleared route input	a/c 1 required
Positional data	required
Velocity data	not required

Alert: T1 after deviation (to be determined)
T2 not used

7.4.5.9 Unauthorized traffic on the taxiways

Unauthorized traffic on the taxiways could be identified traffic (aircraft or special vehicle) or unidentified traffic, which is moving on one or several taxiways without permission of ATC (ground controller).

Identified traffic is moving with active mode S transponder, which makes it possible for the system and for the controller to identify the target. As far as traffic that is not allowed to move on the taxiways is detected, it is an intruder and it automatically is a hazard to other traffic moving on the taxiways. The air traffic controller could try to establish contact to the unauthorized traffic in order to clarify the situation and to give instructions to the pilot or driver of the unauthorized traffic. If it is not possible to establish contact to the intruder the controller can make assumptions about the intention and routing of the intruder, but depending on the kind of intruder (aircraft or vehicle) this may be not very certain. In any case the controller should separate all other traffic taxiing on this particular part of the manoeuvring area from the intruder in order to avoid collisions.

As far as the controller is usually working in a busy environment it is necessary that the system triggers an acoustical and optical alarm as soon as the intruder enters a taxiway.

Unidentified traffic is not moving with active mode S transponder and could not only be aircraft or special vehicle, but also other vehicle (e.g. trucks from external companies) or could even be mowers or pedestrians. This traffic is also categorized as an intruder, it is even more dangerous than the identified intruder, as far as the controller does not know anything about the kind of traffic and intended routing. The controller should try to identify the traffic by visual observation and take measures to prevent collisions with other taxiing traffic as described above.

The system should trigger an acoustical and optical alarm as soon as it detects the intruder (primary target on SMR).

7.4.5.10 Unidentified traffic on the taxiways

Unidentified traffic on the taxiways could be unauthorized or authorized traffic.

The procedure for unauthorized unidentified traffic is described above in i).

If the traffic is authorized this means that the controller has issued a clearance for the traffic (aircraft or special vehicle) to move on the taxiway (taxiways), but the identification is not established or lost. This could either be due to an inoperative or switched off mode S transponder (in an MLAT environment) or due to a shaded area (in an SMR only environment) or due to the failure of one or several MLAT sensors.

The system should trigger an information coding as soon as it detects an identification loss. The controller then should try to re-establish identification and take measures to prevent collisions with other traffic moving on the taxiways.

7.4.5.11 Crossing of a lit stop bar

A pilot or a vehicle driver should never cross a red stop bar. Red stop bars are mainly used to protect the runway safety strip from any unauthorized entering of an aircraft or vehicle. In some cases red stop bars could also be used to protect segments of taxiways. The controller should switch off the respective red stop bar every time he approves an aircraft or vehicle to enter the runway or the protected part of the taxiway. This means that the crossing of a lit stop bar always leads to an incident, in most cases to a runway incursion with the risk of a collision with arriving or departing aircraft.

An acoustical and optical alarm immediately needs to be triggered as soon as the system detects the crossing of a lit stop bar.

7.4.6 Plan deviation detection (C3)

This safety net functionality deals with short term deviation detection which is predicted to take place when an unauthorised incursion into restricted areas, runways and taxiways by either aircraft or vehicles.

7.4.7 Support to Ground Clearance and ATCO coordination (C3)

To support Routing function “control” activities, the taxi route can be transmitted via data link. For the time, whether the utilisation of data link can also be used to transmit ground clearances whilst aircraft is moving on the ground is a strong ATCOs’ concern, but will be investigated with EMMA2.

EMMA2 focus will also lay on the feasibility and limitations of a mixed voice/data link control environment.

note: The description of possible data link operations included in this document has been extracted from CASCADE program, thus shall be considered only as baseline ideas for EMMA2 activities.

A data link service will provide automated assistance and additional means of communication to controllers and pilots when performing communication exchanges during ground movement operations.

The range of targeted operations includes:

- Start-up , e.g. the request by the flight crew and the delivery by the controller of the start up approval as well as all related messages;
- Pushback , e.g. the request by the flight crew and the delivery by the controller of the pushback clearance as well as all related messages;
- Taxi routine; this encompasses:

- a) The request by the flight crew and the delivery by the controller of the first departure taxi message, including authorisation to taxi and the routing description up to the departure holding point.
- b) Routine ground movement which are messages which occur:
 - ✓ For departure phase: between the time when the aircraft starts moving on its own power or when the flight crew has acknowledged the Taxi out clearance, whichever is later and the arrival at its departure holding point and
 - ✓ For arrival phase: between aircraft landing and its engines shutdown at the assigned parking position.

During departure taxi phase, the flight crew would request the D-TAXI clearance from the tower ground controller. The tower ground controller would then issue the D-TAXI response. The flight crew manoeuvres the aircraft according to the taxiing instructions. The Tower Ground Controller monitors the taxiing of the aircraft assisted by A-SMGCS and intervenes by voice if required. The tower ground controller hands over the aircraft to the tower runway controller when the aircraft reaches the handover point – the handover is performed via voice to retain R/T communication as a back-up solution and as a primary means for safety critical clearances (e.g. crossings, line-up, take-off and landing).

During arrival taxi phase, the Tower Runway Controller issues the “Landing Clearance” to the flight crew. The Tower System routing service would provide a recommended D-TAXI most suitable taxi route including a most suitable runway exit and the taxi-in route plan to the Tower Runway Controller. The Tower Ground Controller would use the D-TAXI route information to verify the aircraft’s assigned route from the landing runway nominated exit point to the gate before landing.

The following operating methods have been extracted from ‘*Cascade¹⁰ Stream 1 Air Traffic Data link Services*’ document. These operating methods are used as a starting point within the EMMA project and will be updated with EMMA2.

D-TAXI start-up / pushback possible operating methods:

- a) If relevant, the aircrew transmits a start up (resp. pushback) request to the Controlling ATS unit via data link, in accordance with the local airport procedures;
- b) The Controlling ATS unit transfers a logical acknowledgement to the aircraft indicating that the start up (resp. pushback) request is valid and is available for display to the controller;
- c) The start up (resp. pushback) clearance and/or related message is composed (or selected) by the Controlling ATS unit based on flight related data, apron data and ATM data; the Controlling ATS unit transmits the composed start up (resp. pushback) clearance to the aircraft via data link, or a ‘standby’ response message, to indicate that the request has been received and a response will be sent shortly, or an ‘error’ message. Then the aircraft transmits a logical acknowledgement to the Controlling ATS unit indicating that the message is valid and is available for display to the flight crew.
- d) The aircrew is notified of the received message. The aircrew verifies the operational contents of the composed start up (resp. pushback) clearance message, and transmits a

¹⁰ CASCADE: Co-operative ATS through Surveillance and Communication Applications Deployed in ECAC project

response message via data link. The Controlling ATS unit transfers a logical acknowledgement to the aircraft.

D-TAXI first departure taxi-out possible operating method:

- a) After having completed its (eventual) push-back and start up procedures, aircrew transmits a taxi out request to the controlling ATS unit via data link..
- b) The Controlling ATS unit transfers a logical acknowledgement to the aircraft indicating that the taxi out request is valid and is available for display to the controller;
- c) The taxi-out clearance is composed (or selected) by the controlling ATS unit based on flight related data, apron data and airport surface management data. The controlling ATS unit transmits the composed taxi out clearance to the aircraft via data link, or a 'standby' response message, to indicate that the request has been received and a response will be sent shortly, or an 'error' message. Then the aircraft transmits a logical acknowledgement to the Controlling ATS unit indicating that the message is valid and is available for display to the flight crew.
- d) The aircrew is notified of the received message. The aircrew verifies the operational contents of the composed start up (resp. pushback) clearance message, and transmits a response message via data link. The Controlling ATS unit transfers a logical acknowledgement to the aircraft.

D-TAXI possible taxi (update) operating method:

During the effective taxi of the aircraft, routine messages may be transmitted via data link. It is suggested in CASCADE OSED document that "*the pilot (resp. the controller) identifies a situation requiring a data link message to be sent to the controller (resp. pilot) in case of aircrew-initiated (resp. pilot-initiated) exchange*".

Type of situations which may require a data link message as well as operational conditions shall be specified and tested carefully. Thus this type of transmission for taxi clearance will have to be assessed during EMMA 2 validation.

Possible associated operating methods are as follows:

- In case of an uplink message (initiated by the controller),
 - a) The controller would initiate a taxi update message, preferably by selecting message elements from a predefined elements list.
 - b) The aircraft transfers a logical acknowledgement to the controlling ATS unit, indicating that the request is valid and is available for display to the aircrew.
 - c) The aircrew is notified of the received message, and verifies the operational contents of the message, then
 - ✓ Either transmits a response message via data link, or
 - ✓ Composes (selects) a response downlink message.
 - d) The controller is notified of the received message
 - ✓ The controlling ATS unit transfers a logical acknowledgment to the aircraft;
 - ✓ If the downlink message is a response, it shall be considered as an aircrew-initiated message.

- In case of an downlink message (initiated by the aircrew),
 - a) The pilot initiates a taxi update downlink request preferably by selecting message elements from a predefined elements list.
 - b) The Controlling ATS unit transfers a logical acknowledgement to the aircraft indicating that the request is valid and is available for display to the controller;
 - c) The controller is notified of the received message then composes (selects) a response - based on ground data, airport surface management data, and flight related data.
 - d) The C-ATSU transmits the composed taxi update clearance to the aircraft via data link, or a “standby” response message, to indicate that the request has been received and a response will be sent shortly, or an “error” message. The aircraft then transmits a logical acknowledgement to the controlling ATS unit indicating that the taxi update clearance is valid and is available for display to the flight crew.

The aircrew is notified of the received message. The aircrew verifies the operational contents of the taxi update clearance message, and transmits a response message via data link. The Controlling ATS unit transfers a logical acknowledgement to the aircraft.

7.4.8 Apron / Stand / Gate conflict detection procedures (C4)

Four plus one (five) operational conflict situation have been studied. The fifth (“Aircraft approaches the wrong stand”) is not mentioned with ICAO doc 9830 but has been added by EMMA operational people because there might be a potential operational benefit.

7.4.8.1 Aircraft movement with conflicting traffic

If the predicted trajectory of two or more aircraft has a crossing point, “T” is defined as the time remaining for the two (or more) aircraft to reach the trajectories crossing point. T1 and T2 are parameters to be adjusted locally according to specific circumstances such as visibility, conflict location, etc.

1. $T > T1$ – No warning
2. $T1 \geq T \geq T2$ – Will trigger an ‘information’ coding
3. $T2 \geq T$ – Will trigger an ‘alarm’ coding

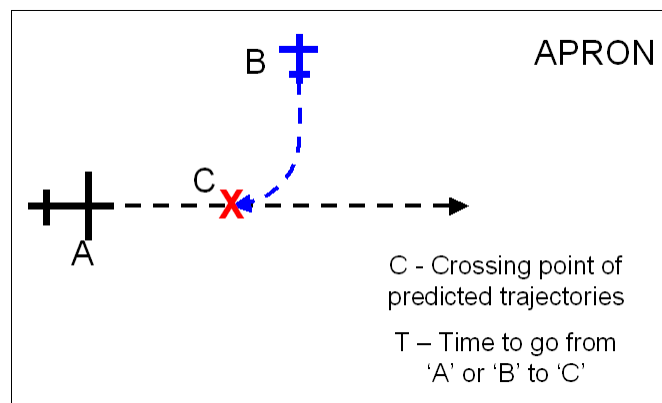

7.4.8.2 Aircraft movement with conflicting stationary objects

If the predicted trajectory of the aircraft contains the position of a stationary object, “T” is defined as the time remaining for the aircraft to reach the stationary object position. T1 and T2 are parameters to be adjusted locally according to specific circumstances such as visibility, conflict location, etc.

4. $T > T1$ – No warning
5. $T1 \geq T \geq T2$ – Will trigger an ‘information’ coding
6. $T2 \geq T$ – Will trigger an ‘alarm’ coding

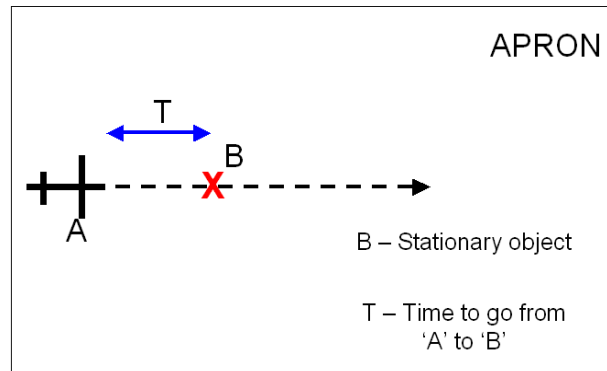

7.4.8.3 Aircraft exiting the apron / stand / gate area at unintended or non-approved locations

The only possibility to manage such situation is to let the system know what the taxi route that the aircraft should follow is. This could be done by means of voice recognition techniques, either through manual input in the system, and/or by obtaining the information from other data sources if possible (e-strips) or by defining standard taxi routes. Once this initial step is achieved, any deviation from the specified taxi route should be reported by the system as an alarm coding.

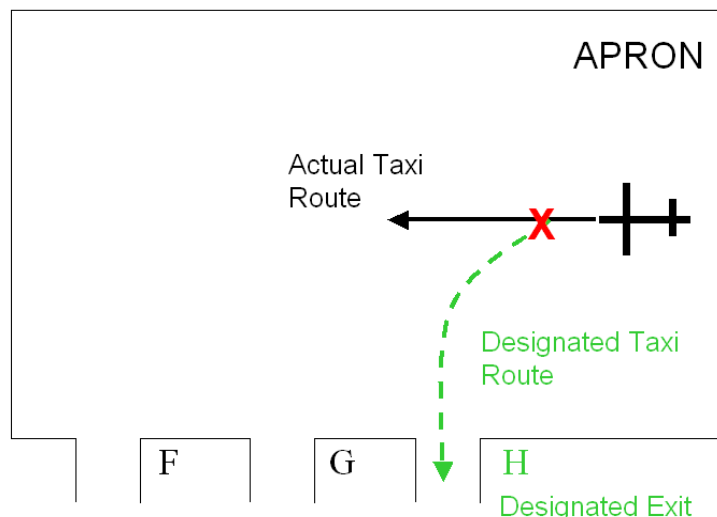

7.4.8.4 unidentified traffic in the apron / stand / gate area

Whenever there is unidentified traffic in the apron/stand/gate area, an information coding should be triggered, in order to change its status to “identified”. If the traffic conflicts with other traffic or stationary objects (see previous points), this should trigger an alarm coding.

7.4.8.5 Aircraft approaches the wrong stand

If an aircraft approaches a stand different from the assigned, this situation should trigger an alarm coding.

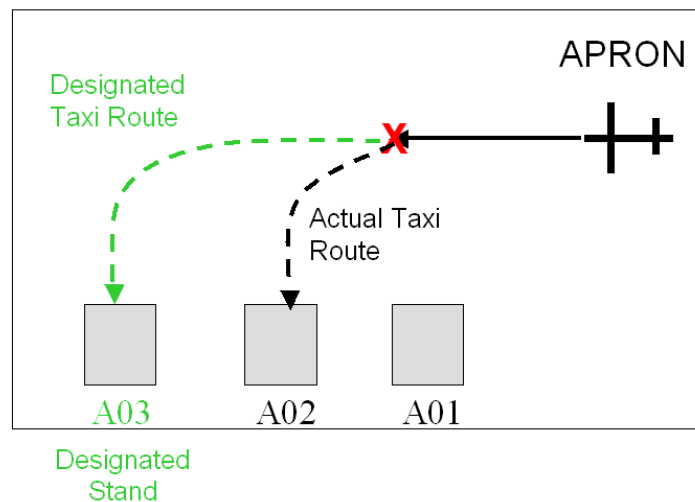

Note: would a safety net take into account the five described rules, it should be ensured that the number of nuisance alarms should reach a very low level. If not, the ATCO will take more time to solve each alert than to manage its traffic;

7.5 Routing Procedures

ICAO-9830 states that “either manually or automatically, the routing function of an A-SMGCS should:

- be able to designate a route for each **aircraft** or **vehicle** within the movement area;
- allow for a change of destination at any time;
- allow for a change of a route;
- be capable of meeting the needs of dense traffic at complex aerodromes, and
- Not constrain the pilot’s choice of a runway exit following the landing.

A-SMGCS routing and guidance services are separate, the routing service dealing with the generation and assignment of the route whereas guidance service deals with the transmission of the route to aircraft and vehicles. If the transmission of a route includes clearances to be followed by pilots and vehicles drivers – then it is “control”.

The assignment of a route can be performed manually, semi-automatically or automatically (section 2.5.2.1 ICAO doc 9830). The ICAO allocation of routing levels in terms of automation is adopted by EMMA:

- If the assignment of a route is performed by the control authority without support of automation, routing is manual.

- b) In a semi-automatic mode, assignment of routes is also carried out by the control authority, but the routing function should also provide the control authority with advisory information on designated routes.
- c) In an automatic mode, the routing function should also assign routes and provide adequate information to enable manual intervention in the event of a failure or at the discretion of the control authority.

The EMMA ATC Controllers have confirmed their interest to obtain the taxi time associated to the taxi route and to be notified of any mismatch with time constraints for the aircraft (CFMU slot).

EMMA ATC Controllers stress that more precise estimated taxi times will contribute to airline ground operations and CFMU regulations.

EMMA OSED-update¹¹ document has identified four logical steps for dealing with ATCO routing service, e.g.:

- **R1:** manual routing (section 7.7.1);
- **R2:** semi-automatic routing (section 7.7.2);
- **R3:** automatic routing (section 7.7.3);
- **R4:** runway occupancy planning (section 7.7.4).

7.5.1 Manual Routing (R1)

In manual routing, the route is mentally produced by the ATCO without any support of automation. From an ATCO point of view, routing and guidance functions are currently mixed (voice message). Once mentally produced, different alternatives for route assignment (input in the system) might be used (non exhaustive list):

- a) via the A-SMGCS surveillance display, by selecting a target with the mouse cursor and signing the route by clicking on topographical waypoints (topological nodes) until the final position is reached;
- b) via keyboard (alphanumerically) into the electronic flight stripes (EFS);
- c) Via speech recognition.

Compared to current way of working, it is foreseen that manual input of routes in the system could provide additional workload to the ATCO. It is too early to prejudge the way by which the ATCO might input the taxi route in the system (technical aspects and human factors guidance are required for acceptability purpose). But any solution which would result in increasing their workload would be rejected by ATCOs. Thus the assessment of possible solutions (who performs manual input, how, in which conditions) versus this risk and potentiality for mitigation should be carefully addressed during EMMA2. Maintaining an acceptable level of ATCO's workload is definitely a key issue for acceptability.

7.5.2 Semi-Automatic Routing (R2)

In a semi-automatic mode, some support of automation is introduced to collect advisory information and compute the most suitable taxi route based on a valid path from the start point to the intended end point taking into account available constraints such as local standard routes, local limitations for taxiways (LVP conditions), type of aircraft, closed taxiways, restricted areas, obstacles, temporary hazards; intermediate waypoints, and time constraints (e.g. blocked runways that are known in advance).

¹¹ D.1.3.lu

If a system would compute and provide them with a taxi route proposal - which could be either standard taxi route or not, depending on the European airport considered -, the conditions used to determine this route should be reliable and up-to-date. The system should be highly responsive: any real time information that would modify the constraints - for instance blocked or closed taxiway - should immediately be captured by the system and used for determining the **most suitable taxi route**. Non-availability of proposed routes by the system, errors, and delays in taking into account evolving constraints would probably lead the ATCO to disregard the function.

Departure Flight:

Independently of the associated HMI, the system should propose the most suitable route, which takes into account all constraints. This initial proposal could be made to the clearance delivery position¹² on request. The Clearance Delivery Controller could have the possibility:

- b) To visualise and electronically acknowledge or reject the route proposed by the system;
- c) To assess constraints that have been taken into account for its determination;
- d) To add specific constraints (for example related to taxiway intersections).

Once allocated the initial route it is been transmitted to the cockpit when a point to point data link environment is available. In the cockpit the route is presented on the electronic moving map in a graphical way. However, the route has not been cleared by the ground controller. The route transmitted by the clearance delivery announces the route to be expected to be cleared by ground and tower controller. The ground or tower controller would still have the possibility to modify the initial taxi route if necessary.

Arrival Flight:

The system should be able to determine the most appropriate exit related to the most efficient (standard) taxi route to reach the final parking position. However, following (9830, section2.5.2.1), *“the routing function of an A-SMGCS should not constrain the pilot’s choice of a runway exit following the landing”*. As a consequence, the routing system proposes the most appropriate runway exit that implies that the aircraft should not vacate earlier but allow the crew to vacate later if certain reasons make it necessary. The Runway ATCO could provide the initial taxi route via data link to the pilot at least before the aircraft passes the outer marker.

Re-routing of movements on the surface:

Re-routing of movements is an exception but occurs from time to time (e.g. after a route deviation, change of operational conditions, etc). Depending on the level of automation of the routing function, different procedural scenarios are conceivable. In any case, the routing function is able to compute a new valid route. Whether this new route has to be requested by the ATCO or whether the route is adapted automatically and has only to be re-cleared by the ATCO (via voice or data link) depends on the maturity level of the routing function.

7.5.3 Automatic Routing (R3)

Compared to manual and semi-automatic routing where the assignment of routes would be carried out by the ATCO, the system in that case would automatically assign routes. However, the system would provide adequate information to enable manual intervention in the event of a failure or at the discretion of the control authority.

Some issues associated to this level of automation encompass:

- a) The level of confidence (associated to system reliability) in the system to determine taxi routes taking into account all real-time constraints. Importance should be granted to avoid any

¹² If a clearance delivery control position is available always depends on how ATC is organised on a specific airport. Supplementary, the first ATCO in the departure loop (preferred is a non-executive Ground or Tower Controller) should overtake this task.

assignment of unavailable route for any reason. The system should facilitate the introduction of updated information e.g. taxiway closed for a defined period of time due to work in progress.

- b) In case of system failure or at discretion of the ATCO, manual intervention should be enabled.
- c) As the system will need complete and reliable information necessary to the ATCO to perform route assignment, the support of a planning function is needed. The planning function interacts with the routing function and other information resources to compute best start-up times, off-block times, departure times and a best departures sequence, based on flight plan information, calculated taxi times, weather information, surveillance and control.

In order to get the best benefit of an automatic routing function supplemented with a planning function, operating procedures need to be changed most probably. Strict planning on the basis of “first come first served” can also be managed by an advanced planning tool but with very less benefit in terms of efficiency. To implement an efficient departure sequence the planning function needs a certain planning horizon. In contrast to nowadays procedures, where the pilot calls in and request the start-up clearance, it must be aimed that an EOBT is negotiated and confirmed between ATC and the aircraft operator right in advance to meet both the airline constraints and the constraints referring the planning function to get efficient surface movements. That would lead to a point where the ATCO, in accordance to the computed start-up time, requests the flight crew to start up their engines. Appropriate interfaces have to be designed to support this information exchange.

7.5.4 Runway Occupancy Planning (R4)

Runway Operations Planning deals with the tactical planning of runway usage by different arriving and departing flights. This should be addressed by integrating arrival and departure management tool.

The final goal of a Runway Occupancy Planning tool is optimising the runway use, by means of providing the most convenient sequence of aircraft according to certain factors and restrictions. Usually airports specify the minimum applicable separations between two aircraft under a set given conditions. These minimum applicable separations between aircraft are fixed according to wake vortex, speed, SIDs, aircraft type, weather conditions, minimum radar separation, take off position, etc.

An “adequate” sequence for a group of aircraft will correspond to the case that, respecting the minimum applicable separation for all pairs of aircraft, the resulting total separation between the first and last aircraft of the group is the minimum possible¹³.

Currently ATCOs optimise the sequence of aircraft available quite before the holding point. However if an efficient planning tool was available, it would be easier for him/her to alternate aircraft on diverging SIDs or tracks, as the tool will make these aircraft available at the holding point at the right time.

Increasing the efficiency of the airport system is therefore possible by planning ahead the time aircraft will be at the holding point. This could be possible by measuring and analysing the push back and taxi times for combination of aircraft type, stand position, runway access (for departures)/ runway exit (for arrivals) and weather conditions. This would lead to determine the ideal times to approve the start up and give the push back or taxi clearances, so that the final sequence of aircraft on the runway is achieved¹⁴.

¹³ Minimum required separation between aircraft according to wake vortex, speed profiles, minimum radar separation or local restrictions has to be respected in ALL cases.

¹⁴ Airport/CFMU slot needs to be taken into account in all cases.

Procedures and functions should be developed to guarantee that the planning tool results in an efficiency increase maintaining the required level of safety. Just as an idea, a function of the system could be to generate a message for the ATCO and pilot few minutes before the “target” start up and/or push back approved. This would make them aware of the time left to proceed.

It should be noted that a non-correct use of a planning tool could result not only in a non-optimised sequence but in a reduced efficiency compared to the actual situation. For this reason, it could be convenient to run awareness campaigns about the importance of achieving the targets times.

Setting up procedures associated to the use of a departure manager is considered as rather immature, but should be considered in EMMA2.

7.5.5 Summary

The introduction of routing service, whatever the automation level is, will impact the ATCO working methods. Strong emphasis should be stressed in EMMA2 on human factors’ impacts in order to assist the operators to act safe and efficient.

7.6 Guidance Procedures

The guidance function of an A-SMGCS (ref. Doc 9830) should:

- a) Provide guidance for any authorised movement and be available for all possible route selections;
- b) Provide clear indications to pilots and vehicle drivers to allow them to follow their assigned routes.
- c) Enable all pilots and vehicle drivers to maintain situational awareness of their positions on the assigned routes;
- d) Be capable of accepting a change of route at any time;
- e) Be capable of indicating routes and areas that are either restricted or not available for use;
- f) Allow monitoring of the operational status of all guidance aids; and
- g) Provide online monitoring with alerts where guidance aids are selectively switched in response to routing and control requirements.

The OSED document has identified two logical steps for dealing with ATCO ground guidance services:

- **G1:** Manual switched ground guidance (G1), section 7.8.1;
- **G2:** Automatic switched ground guidance (G2), section 7.8.2.

7.6.1 Manual Switched Ground Guidance (G1)

Manual operation implies that the visual guidance system will be operated via a light board or a display, which shows the topography of the airport movement area and the traffic lights installed as well as their on-off-status, and provides means to switch the lights on and off.

A possible associated operating method for dealing with a taxi route assigned to an aircraft (once the respective taxi route clearance issued) is as follows: the light board operator will switch on the centre line light segments from the actual position of the aircraft up to the intended end of the taxi movement, which will be signalled by a red stop bar. The centre line segment behind the stop bar will remain dark.

Benefits linked to the use of this service might be questioned. In particular, switch of segments operated manually might reduce capacity and safety as you don't monitor the traffic while switching segment(s) and would induce high costs for airports to be equipped.

Detailed investigations shall be conducted during EMMA2 to demonstrate the added value of this service to ATCOs.

7.6.2 Automatic Switched Ground Guidance (G2)

Automatic switched ground guidance assumes that a taxi route displayed and accepted by the controller via an entry to the system, will trigger the guidance function to automatically switch on the respective centre line segments from the actual aircraft position up to the intended holding position, where the red stop bar is switched on. As a lighted segment is left or the stop bar is reached, the segments behind the aircraft will go dark.

If and how such system can be used on the ground is not known, thus setting up associated procedures is considered as rather immature, but might be considered in EMMA2.

8 Operating Procedures for Flight Crews

8.1 Introduction

Several flight crew functions associated to primary services have been identified in the OSED document, e.g. airport moving map, surface movement alert, ground traffic display, CPDLC ground clearance and taxi uplink, braking and steering cues, HUD surface symbology guidance, Ground / Air Database Upload, Automated Taxiing, Traffic Conflict Detection.

Warning: as the majority of these services are under definition at a high level, the maturity level of potential procedures (when possible) or even initial guidance for use is subject to debate. At this stage of the EMMA project, they have to be carefully considered as preliminary guidance. Consolidation work shall be performed during EMMA2 project.

8.2 Basic Procedures

ATC-Clearances

No flights requiring an ATC clearance shall commence take off without such clearance. All ATC clearances, altimeter settings and RWY in use must be read back including the full call sign.

Standard phraseology must be used. Wording must be clear, precise and unmistakable. A written record of the initial SID, any significant re-clearance and deviations from planned figures must be made on the Operational flight plan.

The commander is responsible to ensure that:

- Application of received clearances is safe with respect to terrain clearance during climb / descent and en-route;
- Compliance with the provisions of a clearance will not violate other regulations (e.g. night curfew).

Pre-flight procedures in regard to A-SMGCS

Operations in A-SMGCS environment require a functional Mode-S transponder which is redundant, i.e. two independent sets are provided. They can be switched XPDR/ON/AUTO/STANDBY/OFF - switch settings depend on individual mark/model – by the flight crew. During cockpit preparation it must be ensured that the transponder is operable and switched to standby thus electrically supplied but not operating.

Depending on the type and model of the individual transponder it has to be assured that the device starts operating latest when requesting push-back/taxi clearance.

For more details on Transponder Operating Procedures, refer to Chapter 4.

Lookout during ground operations

The flight crew has to maintain a constant lookout and avoid other traffic during all phases of flight. Radar service advisories may be helpful in detecting other traffic¹⁵. Any activity diverting attention (e.g. paper work, FMS insertions) must be reduced to a minimum within an airspace deemed critical by the flight crew, e.g. whilst taxiing in- and out,

Taxi

During taxi the flight crew member manipulating the aircraft should concentrate on steering the aeroplane, while the other flight crew member should concentrate on navigation and has to give advice

¹⁵ Reminder : regarding departure aircraft, TCAS should not be selected before receiving the clearance to line up. For arrivals, TCAS should be deselected when vacating the runway.

from taxi chart, including heading information and visual cues to be expected. Surface markings must be observed. If there is any doubt about the position, the aeroplane shall be stopped and ATC or apron control shall be informed. Holding position markings and signs must not be passed without clearance. Lighted stop bars must not be crossed. In the absence of such markings or visual aids the aeroplane shall hold at least 70m clear of the active runway.

Before take-off the flight crew must verify by all possible means that the aeroplane is lined-up at the correct position.

Commencement of Take-Off Roll

The take-off should be commenced at the beginning of the runway. If performance permits, flight crews should refrain from sharp turns during line-up in order to avoid unnecessary stress on wheels and tires. Depending on performance intersection take-offs are permitted.

On closely spaced runways and when VFR traffic is in sight of the flight crew TCAS should be selected to TA only in order to avoid undesired RA's.

Initial Communication with ATC after take-off

Initial communication with ATC should be established as soon as practicable or as instructed but not before "gear lever up" and 400ft AGL.

Parking procedures

When entering any parking or holding position the assisting flight crew member calls out as soon as possible the markers, signs, indicators, etc. he has identified. The flight crew member manipulating the aircraft confirms verbally. The active transponder shall remain in XPDR or equivalent and AUTO when available; switching to STANDBY or OFF - depending on individual mark/model - shall be accomplished when the aircraft is fully parked.

8.3 Supplementary Procedures

8.3.1 Preamble

Pilot considerations have been depicted in ICAO Doc 9830 section 2.6.11 under 14 desirable requirements.

EMMA D.1.3.1u OSED document (section 2.2, services to flight crews) identified and mapped these requirements on on-board functions, i.e. airport moving maps, surface movement alert, ground traffic display, CPDLC ground clearances and taxi route uplink, HUD surface guidance symbology, braking and steering cues functions.

Four logical expected steps (e.g. A1¹⁶, A2, A3 and A4) for flight crew services have been identified in the OSED document, (see sections 3.2.1.1 and 5.1):

- **A1:** Airport Moving Map (section 8.3.2), Surface Movement Alerting (section 8.3.3), Braking and Steering Cues for landing roll (section 8.3.4);
- **A2:** Ground Traffic Display (section 8.3.5), CPDLC Ground Clearances and Taxi Route Uplink (section 8.3.6), Braking and Steering Cues during taxi operations (section 8.3.7), Ground Air Database Upload (section 8.3.8);
- **A3:** HUD Surface Guidance (section 8.3.9);
- **A4:** Automated Steering (section 8.3.10).

Important Remark:

¹⁶ Airborne 1 (A1) ... Airborne 4 (A4)

Since most of these functions are not yet implemented and/or under research, the following list of new/modified/changed flight crew duties and tasks linked to these functions is necessarily incomplete and based on current knowledge of relevant systems.

Therefore this description shall not be utilized as a tool to develop Standard Operating Procedures (SOPs) but rather as preliminary guidelines.

In the following, a standard crew complement of two has been assumed; however on long range flights a third pilot might be integrated with specific tasks and duties which are partly listed in this description.

Whilst the aircraft is on the ground it is assumed that the commander (CM 1) is taxiing the aircraft; the first officer will be the assisting pilot (CM 2). When taking off, during flight and until after landing this role might change: Pilot Flying (PF) might be CM 1 or CM 2, and Pilot Not Flying (PNF) will be the assisting pilot which can be CM 1 or CM 2.

8.3.2 Airport Moving Maps (A1)

Airport Moving Maps will supplement the out-of-window situation assessment by displaying own ship position with respect to aerodrome geographic locations and the aerodrome referenced in the ATC instructions. The navigation task for the flight crew will thus be primarily based on visual observation. In particular ICAO Doc 9830 (section 1.3.9) states that *“for low visibility conditions, the pilot may need suitable avionics, such as a moving map, to monitor progress and compliance with the assigned route”*.

The Moving Map function will enhance the situational awareness of the flight crew and ease navigation on airports, especially at complex, congested and unfamiliar locations. The overall level of flight safety when manoeuvring on the ground will be considerably increased.

It is considered essential that - at least for the beginning period - redundant maps and charts on paper or on electronic format are available and used for crosscheck purposes, most probably derived from the identical data source/database supplier, and used by the flight crew. If an electronic format is used, the manufacturer/database supplier shall guarantee the reliability and integrity of data.

It is assumed that airport moving maps will be integrated in the EFIS (Electronic Flight Instrument System) design - or equivalent- of new aircraft, i.e. scalable like for the Navigation Display (ND); thus it is believed that no dedicated cockpit display will be provided.

Taxiing solely thanks to the sole electronic picture might be conceivable, from an airline perspective however beyond relevant operational issues for taxiing in low visibility conditions. Certification related to the airport moving map for autonomous taxiing would represent a costly challenge compared its use some days in the year.

8.3.2.1 Departure Flights

- Normal Visibility Conditions:

Instead of using the airport taxi map as the primary source for navigation and orientation the Moving Map picture will provide a consistent, scalable graphical representation of possible taxi routes for take off. Standard Operating Procedures (SOP's) for flight crews will have to be developed how to manage safe taxiing based on visual observation and information derived from the Moving Map under a multi-crew complement.

- Low Visibility Conditions:

As the Moving Map will only supplement the navigation task for the flight crew taxiing an aircraft to the take off position in low visibility conditions taxi speed will be necessarily slower compared to normal visibility conditions; however taxi speed will be faster than without using the Moving Map;

The commanders responsibility of the respective flight to avoid a possible collision with another aircraft/obstacle/object will not change in the near future irrespective of new services proposed under A-SMGCS technology.

Depending on the day to day level of accuracy, integrity and reliability of the Moving Map function, flight crews will more and more base their navigation task on the electronic information thus minimizing queries to ATC where to taxi. Navigational errors will significantly reduce.

Notes:

1. It must be emphasised that safety critical information, e.g. the location and the status of stop/clearance bars shall be provided consistently.
2. On-board backup maps and charts or equivalent shall supplement moving map displays and must be used by flight crews, especially under LVO conditions.

- Relevant Operations:

Relevant operations for the use of Moving Maps include preliminary cockpit preparation, cockpit preparation, taxiing and take-off operations:

- ✓ **Preliminary cockpit preparation:** check maps/charts (on paper or in electronic format) available on board for redundancy (CM 2);
- ✓ **Cockpit preparation:** EFIS control panel: select the lowest range, review airport details on the Moving Map display; then crosscheck content with maps/charts or equivalent (CM 1/2);
- ✓ **Taxiing out:**
 - All visibility conditions: navigate the aircraft along the cleared taxi route by visual observation (CM1); crosscheck present aircraft position, taxi route and runway entry point with Moving Map display (CM2).
 - Low visibility conditions: call out relevant information contained on the Moving Map display - e.g. stop bars, crossings, intersections and close runways – (CM 2); crosscheck callouts by reference to redundant maps and charts or equivalent (CM 1).
- ✓ **Take-off:** check correct take off point and runway by visual observation and with Moving Map display (both pilots)

8.3.2.2 Arrival Flights

- Normal Visibility Conditions:

Instead of using the airport taxi map as the primary source for navigation and orientation the Moving Map picture will provide a consistent, scalable graphical representation of possible taxi routes after landing.

It is expected that the map picture of the airport layout with relevant taxi routes after landing will be available in flight; it is assumed that this map picture will provide a reliable data source for the approach briefing. Depending on environmental conditions /runway surface/local procedures, the envisaged runway exit/turn-off point shall be clearly identified.

Standard Operating Procedures (SOP's) for the flight crew will have to be developed; special emphasis shall be put on how to manage safe taxiing after landing based on visual observation and information

derived from the Moving Map - and from the Braking and Steering Cues function - under a multi-crew complement.

- Low Visibility Conditions:

Low Visibility Operations at most airports have prescribed exit routes where and how to leave the active runway, e.g. by illuminated green centre line lights. Thus it is believed that the Moving Map function will have a minor importance compared to the Braking and Steering Cues function on how to identify such routes; however when the aircraft has arrived at the respective exit point the Moving Map will play the identical role as taxiing for take off (see above) under LVO conditions.

- Relevant Operations:

- ✓ **Approach preparation:** both pilots - one after the other - select appropriate range for the Moving Map display; then they crosscheck airport layout, runway exit point, expected taxi route with redundant maps and charts or equivalent (CM 1/2).
- ✓ **Approach briefing:** identify runway exit point using the Moving Map display (Pilot flying / Pilot not flying).
- ✓ **Rollout after landing:** switch EFIS control panel on both sides to Moving Map function (Pilot not flying) if not switched automatically.
- ✓ **Taxiing in:** identical to taxiing out procedures described above.

8.3.3 Surface Movement Alerting (A1)

Based on incident and accident statistics the main Surface Movement Alert impact on flight operations is the provision of an independent and additional safety net.

Surface Movement Alert will provide alerts to flight crew in case of possible risk situations dealing with own ship runway incursion, usage of unsuitable taxiways, deviations from pre-defined routes and/or taxiway guidance/centre line, collision with fixed obstacles.

From a pilot point of view, careful attention should be granted on reducing to safety alerts (neither general warnings nor information).

It is believed that the implementation of sub-functions 'taxiway safety margins control' and 'taxi route conformance' will be difficult due to frequent and short notice changes on the surface (e.g. NOTAMS like "work in progress on taxiway XYZ: use caution"); it is anticipated that such warnings will prone to failure and nuisance; it must be kept in mind that each indication/alert/warning in the cockpit (valid, wrong or nuisance) requires attention and possible flight crew action thus distracting and possibly slowing down taxiing.

Especially any false, nuisance or spurious warning will greatly increase the workload on the flight deck thus leading to a slower taxi speed or stop of the aircraft until the relevance of such a warning can be assessed. Thus an unacceptable high rate of false and /or nuisance warnings generated by the Surface Movement Alert will be a detriment to safety and efficiency.

When any warning/alert is generated, the procedure might be as follows:

- Identify relevance and correctness of warning (CM 1/2);
- Stop the aircraft immediately if the situation is unclear (CM 1);
- Execute ECAM (Electronic Centralised Aircraft Monitoring) action - or equivalent depending on aircraft design - as shown (CM 2).

8.3.3.1 Departure Flights

- Normal Visibility Conditions:

The runway and taxiway alerting function - especially when the cleared taxi route can be up linked - will greatly benefit to traffic flow under high density conditions, e.g. a stream of aircraft taxiing for take off at peak hours.

The importance of 'taxiway safety margins control' and 'taxi route conformance' sub-systems will have to be demonstrated; their reliability and consistency will have to be assessed carefully.

- Low Visibility Conditions:

The Surface Movement Alert function will have an even more important influence on safety and efficiency compared to normal visibility conditions. Navigational errors, wrong or misinterpretation of taxi clearances communicated by voice, 'stand stills' because of unclear situations as interpreted by the flight crew will be reduced. It is expected that the overall traffic flow, especially at peak traffic hours, will benefit from the Surface Movement Alert function.

8.3.3.2 Arrival Flights

- Normal Visibility Conditions:

Equivalent to a departure flight with the following addition:

- Depending of the time constraint, a 'leaving the runway and taxi clearance' will be up-linked and interpreted by the flight crew. Such a clearance should be available to the flight crew as early as possible (before reaching the proposed runway exit point) and should cover a predominant part of the route with reliability. Thus close and timely coordination of TWR and Apron service providers will be important to take full benefit of the Surface Management Function.

The sub-function 'fixed obstacle avoidance' has the potential to further enhance flight safety provided that the current airport layout with up-to-date modifications, e.g. derived from NOTAMS, is maintained in the relevant database.

- Low Visibility Conditions:

Equivalent to a departure flight (see above).

8.3.4 Braking and Steering Cues / Landing Operations (A1)

The objective of Braking and Steering Cues function is to provide tactical support to the Pilot Flying (PF), as a complement to other parts of the A-SMGCS that provide general surface situation awareness information for use by the Pilot Not Flying (PNF).

The support to the PF during landing operations will be used to improve the reliability of runway occupancy times during the landing roll; it should assist the PF in controlling aircraft deceleration in order to exit the runway as planned, or to warn the PF as early as possible if actual braking performance is not sufficient to exit as planned. In the event that the actual deceleration is insufficient to leave the runway at the planned exit, the Braking and Steering Cues function is required to present speed-control cues so that the aircraft can use the next practicable exit with the minimum increase in runway occupancy time. Consequently, the Braking and Steering Cues function should monitor the aircraft speed, aircraft heading, braking/steering effort and efficiency and give changes of advisories or confirmation for the landing roll. It should also determine if the designated runway exit can be used safely.

8.3.5 Ground Traffic Display (A2)

The Ground Traffic Display will receive, correlate and merge passive traffic surveillance data coming from different sources in order to provide the flight crew with the surrounding traffic information (ground/airborne) on an appropriate display and detect potential conflict with other aircraft/vehicle (and associated alert means). Ground Traffic Display is envisaged as a path to conflict avoidance alerting.

It is assumed that not only flight crews will benefit from this service (e.g. access to such consistent and reliable data) but also flight operations and hub control centres.

8.3.5.1 Departure Flights

The knowledge of actual traffic on the apron, manoeuvring area and runways will have considerable relevance to flight operations; up to now flight crews preparing for departure are listening on the ATC frequency in order to get a mental impression of traffic, especially when the outside view is limited; a much more accurate, relevant and consistent picture will be provided to individual cockpits.

Operational decisions, e.g. to expedite or even delay the flight in order to cope with operational irregularities, will benefit from the Ground Traffic display function.

- Normal Visibility Conditions:

The flight crew will be able to crosscheck conflicts' information obtained by Radio Telephony communication, Ground Traffic display function and visual observation. This will result in less ambiguous situations.

- Low Visibility Conditions:

Limited vision to identify potential conflicts will be counterbalanced with the electronic picture: shadow objects and aircraft/vehicles will be then 'visible'. The impact on safety and to some lesser extent to efficiency will be tremendous; conflict avoidance alerting is expected to be a further step.

Similar to the use of TCAS when airborne, SOP's must be developed to address how to cope with warnings depicted on the Ground Traffic display.

- Relevant Operations:

Proposed procedures might be as follows:

- ✓ **On the gate / parking position:** select transponder STDBY (CM 2);
- ✓ **Before pushback, engine start or taxi:**
 - Select transponder XPDR (and AUTO if available) (CM 1);
 - Assess traffic situation (CM1/2);
 - Make operational decision - if any – (CM 1);
 - Assess traffic near/behind the aircraft as shown on the Moving Map and – when relevant -, callout (CM 2).
- ✓ **Taxiing out:** Monitor the surrounding traffic as shown on the moving map (or other appropriate display) and, if relevant, callout (CM 2). Especially the capability to monitor traffic behind the aircraft when pushback is considered as particularly relevant from a pilot perspective.

Lining up: Select transponder TA/RA (CM 2)

8.3.5.2 Arrival Flights

- Normal Visibility Conditions:

It is assumed that the Ground Traffic display picture will be available in flight, i.e. during approach when the briefing for taxiing after landing takes place. With such service the flight crew will be able to better plan and coordinate the taxiing task.

- Low Visibility Conditions:

Equivalent to a departure flight (see above).

- Relevant Operations:

- ✓ **After landing:** when the runway is vacated, select transponder XPDR (and AUTO if available) (CM 2);
- ✓ **Taxiing in:** Monitor the surrounding traffic as shown on the Moving Map display (or other appropriate display) and – if relevant – callout (CM 2);
- ✓ **At the gate / parking position:** select transponder STDBY (CM 2).

8.3.6 CPDLC Ground Clearances and Taxi Route Uplink (A2)

The graphical presentation on a screen in the cockpit where to taxi will ease the cockpit workload considerably; hold instructions clearly marked in dedicated colour coding will enhance safety thus decreasing the eminent potential of ground incidents and accidents.

Taxi route uplink is expected to avoid misunderstandings and, assembled with graphical tools, to provide an assistance to guide the aircraft to taxi on manoeuvring areas:

- From the parking stand (gate) to the runway holding point up before the take-off, and
- From the runway to the stand (gate).

Note: Flight crew tasks to obtain a Pre-Departure Clearance (DCL) and a cleared taxi route are dependent on hardware and software installed in the cockpit. However current knowledge is limited about how the equipment concerned will function; thus the following potential flight crew procedures are preliminary.

8.3.6.1 Departure Flights

The ANSP clearance delivery position should send the initial taxi route, which could be modified later on by the ground controller;

Note: EMMA 2 will look at which information will be transmitted via data link; this might include D-ATIS, D-TAXI, D-RVR, D-NOTAM etc.

- Relevant Operations:

- ✓ **Before Start:**

- Select FMS relevant Data Link menu (CM 2);
- Send DCL request (CM 2);
- Assess received DCL (CM 1/2);
- Accept / reject DCL (through button press with the relevant Data Link menu key) (CM2), and, in case of reject, send new DCL request (CM 2).

✓ **Before Taxi:**

- Send a Taxi request (CM 2);
- Assess transmitted Taxi instructions (including taxi route) (CM 1/2);
- Accept / reject Taxi instructions (through button press) (CM2), and, in case of reject, send new Taxi request (CM 2)

8.3.6.2 Arrival Flights

From a pilot perspective it is highly desirable that an initial proposal encompassing taxi route and best suitable runway exit would be made available on-board before the passing the Outer Marker. However, as the pilot's choice of a runway exit should not be constrained, the system should be reactive enough to compute and propose for each possible runway exit an alternative (initial taxi route associated to runway exit).

Possible associated procedure:

- a) The system automatically transmits the arrival standard taxi route, displayed on aircraft Moving Map in yellow, when the arrival aircraft is near the Outer Marker.
- b) At first contact with the Ground ATCO, the pilot gets the clearance to taxi, using the standard proposed route or any other route.
- c) The pilot validates – after modification, if needed – the taxi route via voice and confirms it on the Moving Map by pressing a button which switches the taxi route (yellow line) to green, indicating that the taxi route has been cleared.

Note: this might help for the beginning; however activation of the actual "clearance" should be initiated by ATCO.

- Normal and Low Visibility Operations:

Depending on time and geographical location of the respective aircraft on the runway when a CPDLC clearance is received in the cockpit identical benefits to departure flights might be expected; it must be stressed that accurate clearance timing (e.g. when such clearance is transmitted) will have a great influence on flight crews' tasks:

- ✓ Both crew members are task loaded during landing and rollout until reaching adequate speed to leave the runway. As a consequence it is assumed that little or almost no capacity will be left to analyse and acknowledge such a clearance earlier than having reached taxiing speed.
- ✓ Transmitting a taxi clearance much earlier, i.e. when the aircraft is still airborne would be beneficial for the flight crew; however such early transmission from ATCO would probably be subject to frequent changes and thus being inadequate.

- **After landing :**

- Assess Taxi Clearance (including taxi route) (CM 1/2);

- **Taxiing in :**

- Accept / reject Taxi Clearance (through button press) (CM2), and, in case of reject, send new Taxi request (CM 2). Such rejects are sometimes necessary as the respective airlines operational control centre might have advised the respected flight of changes in its gate/parking position which is not yet known by ATCO.

8.3.7 Braking and Steering Cues during Taxi Operations (A2)

The support to the PF during taxi operations of the Braking and Steering Cues function should be provided through aircraft position monitoring with respect to:

- a) the taxiway guidance line,
- b) aircraft speed (on the taxiway, when approaching turn or designated holding position) and heading,
- c) steering/braking changes advisories (or confirmation when respecting an acceptable tolerance of the taxiway guidance line or when approaching turn);

It should also cope with any change in the taxi route without discontinuity.

At present there are no preliminary operating procedures available as the system has not yet been analysed by the respective EMMA airline user.

8.3.8 Ground / Air Database Upload (A2)

The function covers the update of the airport mapping data available in the aeronautical database on board as well as the NOTAMs not communicated to the Flight Crews prior to flight and the ATIS information (D-ATIS data link service) (see OSED 2.2.5.1). D-ATIS allows pilots to receive and read ATIS text messages using the aircraft's existing display format, eliminates need for aircrew to manually copy voice ATIS messages by printing them on the cockpit printer, which reduces the workload of both pilots and controllers. Such functionality is today's practice when using ACARS. In addition, D-ATIS information can be enriched with METARs, NOTAMs, SNOWTAMs and PIREPs (D-OTIS¹⁷ service).

As detailed research on the pilots expectations and filtering criteria should be undertaken (for instance through filtering of the messages before they reach the cockpit, in order to minimise the pilot effort as well as the usage of data link), setting up associated procedures is considered as immature (might be considered in EMMA2). Today's procedures when using ACARS on the ground are well developed and available.

8.3.9 HUD Surface Guidance Symbology (A3)

Within the scope of the EMMA Project, the SGS/HUD function is a concept-demonstrator intended for use only in situations where the flight crew has independent means of verifying the support provided. The objective is to provide, using adapted symbology, tactical support to the Pilot Flying (PF) respectively to the CM1 when on the ground, as a complement to other parts of the A-SMGCS that provide general surface situation awareness information for use by the Pilot Not Flying (PNF).

The use of HUD surface guidance symbology is envisaged in visibility condition 4, where the pilot cannot appreciate the instantaneous situation of the aircraft on the manoeuvring area. In such conditions it will be necessary to present on cockpit displays unambiguous information to allow the pilot to taxi the aircraft. It is intended to provide the both pilots with the following information:

- Taxi route: path to follow with stop information (stop bars, traffic stop) associated to taxi clearance;
- Awareness information relative to aircraft situation on taxiway;
- Additional symbology to represent taxiway limits;
- Steering and Braking Cues to the CM 1 during taxi operations (for instance braking cues whenever taxi speeds are too high approaching a turn; steering cues for turn entry and exit information if the visibility is reduced; speed-control cues to allow the CM 1 to minimise wear and tear on the undercarriage whilst maintaining planned taxi timings).

If and how such system can be used on the ground is not known, thus setting up associated procedures is considered as immature (might be considered in EMMA2).

¹⁷ Datalink Operational Terminal Information Service

8.3.10 Automated Steering (A4)

The function covers the performance of steering actions by to the auto-pilot during the taxi movements following the taxi routing as well as ATCO clearances and guidance information (Braking and Steering Cues) (see OSED section 2.2.4.3). If and how such system will be developed and possibly be used on the ground is uncertain, thus setting up associated procedures is considered as immature (might be considered in EMMA2).

9 Operating Procedures for Vehicle Drivers

9.1 Preamble

According to ICAO document 9830 (section 2.6.12.1 and section 2.6.12.2):

‘Vehicle drivers should be provided with the following:

- a) Information on location and direction at all times;
- b) Indication of the route to be followed;
- c) Guidance along the route being followed or guidance to remain within designated areas;
- d) Information, and control when and where appropriate, to prevent collision with aircraft, vehicles and known obstacles; and
- e) Alert of incursions into unauthorised areas.

In addition, the drivers of emergency and operational vehicles should be provided with:

- a) The capability to local the site of an emergency within the displayed range on the system; and
- b) Information on special priority routes;

Three logical expected steps (e.g. V1¹⁸, V2, and V3) for flight drivers services have been identified in the OSED document (see sections 3.3.1.1 and 5.1):

- **V1:** airport moving map (section 9.2) and surface movement alerting (section 9.3);
- **V2:** ground traffic display (section 9.4);
- **V3:** vehicle dispatch and guidance by data link (section 9.5).

Remark: all vehicles do not need to be equipped with such capabilities. It has been considered that only vehicles operating on the movement area have to be equipped.

9.2 Airport Moving Map (V1)

Main benefits related to airport moving maps implementation in vehicles will be provided in low visibility conditions or at airports where the layout is very intricate and complex.

Providing vehicle drivers with an airport moving map function will:

- a) Help the vehicle driver to determine the actual position of his/her vehicle on the airport surface by displaying the own ship position with respect to aerodrome geographic location on a graphical display mounted in the vehicle cockpit.
- b) Supplement the out-of window visual reference to navigate on the airport movement area, thus increasing the situation awareness of the vehicle driver.

All vehicles drivers who are subject to drive on the movement area should receive formal training and certification – in addition to specific driving qualifications, signage and markings - related to the equipment they will operate. In particular, rules, procedures and A-SMGCS aspects in all visibility conditions which would apply to vehicle drivers should be submitted to qualification.

¹⁸ Airborne 1 (A1) ... Airborne 4 (A4)

- Under VIS.1 and VIS.2 conditions, the airport moving map would help in a few cases where the vehicle driver has doubts about his/her location (non experienced vehicle drivers). As markings and signage already play a similar role, the use of an airport moving map as such would be quite limited. Supplementary functionality (surface movement alert function, conflict detection) would increase the interest in airport moving maps in vehicles.
- VIS.3 conditions: the interest for an airport moving map is reinforced as visibility conditions decrease; specific associated procedures for using this equipment shall be set up. Some initial guidance may be provided when specifying these procedures:
 - a) Checking procedures before driving: vehicle drivers shall switch on the equipment and check any failure; under conditions to determine, equipment failure might prevent the use of the vehicle; the identification of the driver should be possible through appropriate logon procedure.
 - b) Driving procedures: vehicle speed shall be adapted to cope with visibility conditions (vehicle speed might be recorded and controlled (post operations analysis)); airport moving map shall be used to check the own ship position versus geographical location; when used in low visibility conditions, surface movement alert and conflict detection functions should supplement airport map position;
 - c) Failure procedure: in case of equipment failure, the aerodrome control tower should be warned by the vehicle driver and guidance (or any adequate measure) provided when necessary for safety purpose.

Note: If other traffic (aircraft and vehicles) is not displayed on the moving map (only own ship position), it should be compulsory when VIS.3 conditions apply to have two persons in the vehicle: one to ensure driving and anti-collision, while the other would follow the map.

9.3 Surface Movement Alerting (V1)

Surface Movement Alerting is an additional service that bases on the AMM functionality. It is recommended to be used by vehicles, particularly by those moving on the manoeuvring area. Similar to SMA for flight crews, it is related to the provision of alerts to the vehicle driver in case of possible risk situations:

- To avoid runway incursions of vehicles, operating on the manoeuvring area;
- To avoid entry of taxiways, which have not been authorized for use by ATC (tower);
- To avoid deviation from pre-defined routes on the manoeuvring area, issued by ATC (tower);
- To avoid collision with fixed obstacles.

This function is expected to provide the maximum benefits under VIS.3 conditions. A combination of audio and visual alerts on the airport map should be provided in these cases. Particular attention should be paid to strictly avoid false alarms.

When the AMM allows the driver to mark areas (runways, taxiways, etc.) that have been restricted by ATC for a certain time and have been told by ATC to the vehicle driver, the driver shall mark this area as restricted at the AMM. This will alert the driver if s/he penetrates this area.

When any alert is generated, the procedure might be as follows:

- Identify relevance and correctness of warning ;
- If the situation is unclear, stop immediately the vehicle and contact the TWR.

9.4 Ground Traffic Display (V2)

The Ground Traffic Display will receive, correlate and merge passive traffic surveillance data coming from different sources (ADS-B, TIS-B);

Compared to the airport moving map (see section 9.2) the ground traffic display will provide the vehicle driver not only with information about his own position on the airport, but also with information about other traffic (aircraft and vehicles) on the apron and manoeuvring area, which gives the vehicle driver a more complete picture about the traffic situation and which will allow the vehicle driver to identify potential conflicts especially in VIS.3 conditions. This will raise situational awareness of the vehicle driver, and it will have a tremendous effect on safety of ground operations. As far as the vehicle driver can rely on electronic information of potentially conflicting traffic in the vicinity of the vehicle, the lack of consistent visual information under VIS.3 conditions can be compensated. The vehicle driver will be able to operate with a similar speed like under normal visibility conditions, which may have a positive influence on efficiency.

9.5 Vehicle dispatch and guidance by data link (V3)

This function covers the provision of vehicle dispatch information (to stand or aerodrome areas) as well as specific guidance information to individual vehicles using data link communications.

If and how such system can be used on the ground, thus setting up associated procedures is considered as immature (might be considered in EMMA2).

In the medium term it is imaginable that means of data link communications can be used to transfer dispatch information and special guidance information to the vehicle driver. Compared to today's procedures where voice communication is used to relay such information to the vehicle driver, this would lead to less ambiguity and a decrease of potential misunderstandings (no readback or hearback mistakes).

At present it is very often the case that vehicle drivers have two sets of voice communication radios in the vehicle – one station for the communication with the ATC tower and a second station for the communication with the own (airport) control centre. As far as both stations are working independently and on different frequencies the vehicle driver hears the communication on both frequencies at the same time. At times when he communicates with the airport control centre he is not able to listen to instructions from the ATC tower. This is a safety risk, and although it is widely used practice, it is unacceptable.

The replacement of the voice communication with the airport control centre by means of data link communication would solve this safety problem of limited listening watch. Data link is a very promising solution for exchange of information, which is not time critical. As far as there is still some problems with guaranteed response times (of less than one second) data link is only partially used for delivery of instructions from the control tower to aircraft. A EUROCONTROL project on D-TAXI procedures is currently under way, first trials will be executed in early 2006 at Brussels National airport with Belgocontrol and SN Brussels Airlines. In particular D-TAXI trials will provide more information about selected procedures versus response times. Results will be available for EMMA2.

The communication between vehicle driver and airport control centre is less time critical, as far as the exchanged information is not used for control and positioning of the vehicle on the manoeuvring area, but is mainly dispatch information (gate numbers and commercial information about aircraft or other vehicles at the airport). It would be beneficial to relay this information by means of data link by the following reasons:

- Increased safety (vehicle driver can constantly listen to ATC tower frequency),
- Less ambiguity (dispatch information is available in a written form and can probably be printed in a similar way like in an aircraft cockpit environment),

-
- Response times and other technical characteristics are sufficient for use in communication between airport control centre and vehicle driver.

10 Operational Requirements

10.1 Methodology

From a methodological point of view, it is proposed to define three levels of requirements for an A-SMGCS:

- Service level
- Functional level
- Architectural level

10.1.1 Service Level

At the service level, the A-SMGCS is seen as a black box providing services to users. This black box interacts with the users but also with its environment and other external systems. At this level, the requirement analysis allows to define the operational requirements from a user point of view and to identify the environmental constraints and the interfaces with external systems.

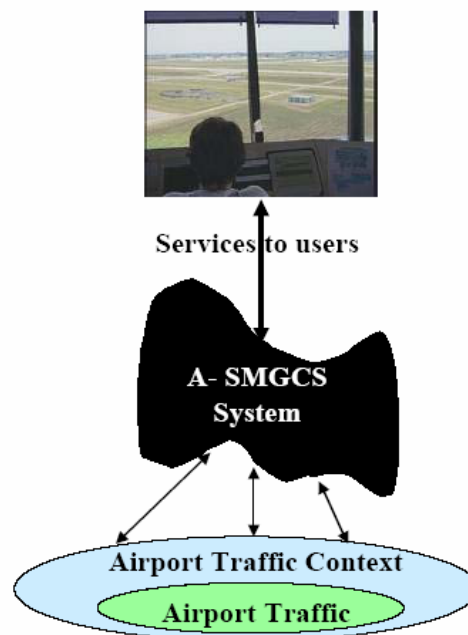

Figure 10-1 : Service level

10.1.2 Functional Level

At the functional level, the requirement analysis interacts with the A-SMGCS which is seen as an interaction of different functions.

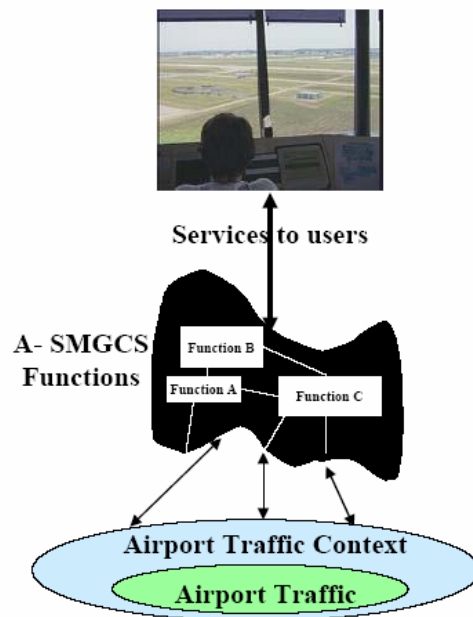

Figure 10-2 : Functional level

10.1.3 Architectural Level

At the architectural level, the requirement analysis defines the physical components of the A-SMGCS which executes the different functions defined previously. The functions are mapped onto the physical architecture.

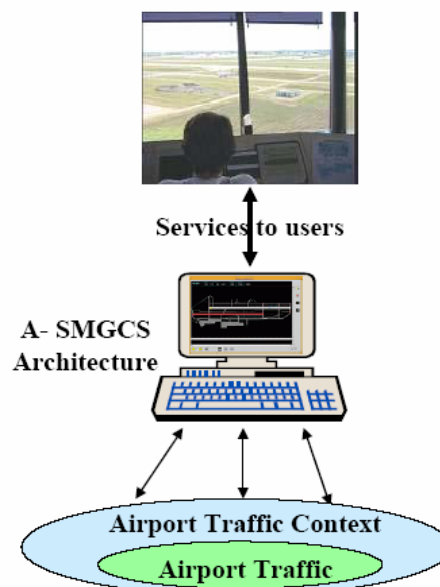

Figure 10-3 : Architectural level

This document does not aim to identify all the above requirements, but focuses only on the first level: operational requirements. These operational requirements are presented in the following sections.

Most of them are drawn from ICAO requirements. In that case, the ICAO requirement number is given as a source.

10.2 General Principles

The requirements related to System Design, Evolution, Operational Range, Responsibilities, Interfaces and Environmental Constraints are listed as "General Principles" while requirements specific to A-SMGCS services are listed in specific sections.

10.2.1 Assumptions

Cooperative

All participating aircraft/vehicles shall be cooperative.

Sensors and Data Fusion

It is expected that more than one type of sensor and a data fusion unit may be needed to meet the following requirements.

Sources: [ICAO A-SMGCS] 3.4.1.3

10.2.2 Requirements

Op_Ds-1-Modularity to fit aerodrome needs

An A-SMGCS shall be composed of different modules required for particular user needs or technological choices.

Note 1: Each aerodrome has its own operational needs and technological constraints. So each aerodrome will only implement the A-SMGCS modules fitting its needs and its technological choices in order to minimize the cost of its A-SMGCS. Consequently, A-SMGCS consists of many elements which, when integrated, are designed to meet the specific operational requirements of an aerodrome.

Note 2: The combination of modules used for any A-SMGCS Level shall ensure that the requirements of this Level are met. It implies that minimum modules are required, i.e. cooperative surveillance.

Sources: [ICAO A-SMGCS] 2.2.5, [EUROCAE-MASPS] 1.8.2

Op_Ds-2-HMI design

The A-SMGCS design concept must be built upon the integration of the fundamental and principal system elements and facilitate the upgrading of those elements whilst maintaining, where possible, the same HMI and references. This is important when considering harmonisation, familiarisation and training requirements, and will allow the evolution of the system design through to a full A-SMGCS with the minimum negative impact on the users' ability to interface with the system.

Source: [EUROCAE-MASPS] 2.5.2

Op_Ds-3-Interoperability

Standards like Standards and Recommended Practices (SARPS) shall be written and used to permit interoperability between the A-SMGCS elements developed by different manufacturers.

Note: Such interoperability will help to maximise commercial and economic benefits for the manufacturer, service provider and user. It should also encourage timely implementation by avoiding a proliferation of different specifications.

Source: [EUROCAE-MASPS] 1.8.4

Op_Ds-4-Standardized Data Format

The data interchange between systems should be performed in a standardized format in order to ensure an adequate exchange of information. ASTERIX will be the standard to be used for surveillance data.

Source: [ICAO A-SMGCS] 2.6.16.2

Op_Ds-5-Self-checking system

A self-checking system with failure alerts shall be in the system design.

Source: [ICAO A-SMGCS] 2.7.5.1

System Failures:

Op_Ds-6-System status

Equipment which shows control data shall both be fail-safe and fail-soft.

Note: The term "fail-safe" in this context means that sufficient redundancy is provided to carry data to the display equipment to permit some components of the equipment to fail without any resultant loss of data displayed.

The term "fail-soft" means that the system is so designed that, even if equipment fails to the extent that loss of some data occurs, sufficient data remain on the display to enable the controller to continue operation without assistance of the computer.

Source: [ICAO A-SMGCS] 2.6.9.1

Op_Ds-7-Failure effect

In case of a failure of an element of an A-SMGCS, the failure effect shall be such that the element status is always in the "safe" condition.

Note: For instance, the element shall not provide wrong data which could impact on safety.

Source: [ICAO A-SMGCS] 2.6.9.2

Op_Ds-8-Self-restartable

An A-SMGCS shall be self-restartable. The recovery time should be a few seconds.

Source: [ICAO A-SMGCS] 2.6.9.4

Op_Ds-9-Restart

The restart of an A-SMGCS shall include the restoration of pertinent information on actual traffic and system performance.

Source: [ICAO A-SMGCS] 2.6.9.4

Op_Ds-10-Audio and Visual indication

All critical elements of the system should be provided with timely audio and visual indications of failure.

Source: [ICAO A-SMGCS] 2.6.9.3

Op_Env-4-Adverse effects

The system should not be affected by:

- a) Radio interference, including that produced by standard navigation, telecommunications and radar facilities (including airborne equipment);
- b) Signal reflections and shadowing caused by aircraft, vehicles, buildings, snow banks or other raised obstacles (fixed or temporary) in or near the aerodrome environment; and
- c) Meteorological conditions or any state of the aerodrome resulting from adverse weather in which operations would otherwise be possible.

Sources: [ICAO A-SMGCS] 2.6.5, 2.5.1.1

Op_Env-5-Radio Spectrum

Those elements of A-SMGCS which require the use of radio spectrum should operate in properly allocated frequency bands in accordance with appropriate national and international radio regulations.

Source: [ICAO A-SMGCS] 3.6.5.1 (N'EXISTE PLUS)

Op_Env-6-Interference to Other Systems

A-SMGCS equipment shall not cause interference to standard radio navigation, surveillance and communication systems.

Source: [ICAO A-SMGCS] 3.6.7.1 (N'EXISTE PLUS)

Op_Evo-1-Operational Change

An A-SMGCS shall be capable of accommodating any change of the aerodrome after being installed, for instance a physical change in layout (runways, taxiways and aprons), or a change in the aerodrome procedures, rules...

Sources: [ICAO A-SMGCS] 2.6.10, [EUROCAE-MASPS] 1.8.3

Op_Evo-2-Technological Change

An A-SMGCS shall be capable of accommodating any technological change after being installed.

Note: as several technologies are candidates to A-SMGCS implementation and these technologies evolve, technological changes are very likely. These changes can be driven by performance enhancements or cost decrease reasons, but also by other ATM services which share systems with A-SMGCS.

Source: [EUROCAE-MASPS] 1.8.3

Op_Evo-3-HMI impact

A-SMGCS evolution shall have a minimum negative impact on the users' ability to interface with the system. This is important when considering harmonisation, familiarisation and training requirements.

Source: [EUROCAE-MASPS] 2.5.2

Op_Evo-4-Modularity for A-SMGCS levels

The design principle of an A-SMGCS shall permit modular enhancements such as implementation of further A-SMGCS levels.

Note: A-SMGCS will evolve from a SMGCS by progressive enhancements to match the desired level of operations. The competent authority will determine, in consultation with the users, whether existing SMGCS needs to be upgraded to A-SMGCS. A-SMGCS for each aerodrome will comprise a different mix of modular components dependent upon operational factors.

Sources: [ICAO A-SMGCS] 2.4.1, [EUROCAE-MASPS] 1.8.2

Op_Evo-5-Cost of evolutions

The design principle of an A-SMGCS shall permit system enhancements at minimal cost.

Source: [EUROCAE-MASPS] 1.8.3

Op_If-1-User interface

A-SMGCS shall enable users to interface efficiently.

Source: [ICAO A-SMGCS] 2.6.16.3

Op_If-2-Operator interface

A-SMGCS shall enable operators to update traffic context or to configure the system to interface efficiently.

Op_If-3-Interface with aircraft/vehicles

A-SMGCS shall be capable of interfacing with all cooperative aircraft/vehicles in order to collect the required traffic data. In particular, it shall interface with existing and future embedded systems.

Source: [ICAO A-SMGCS] 2.6.16.1

Op_If-4-Interface with ground systems

In order to fully benefit from an A-SMGCS by all parties concerned, the system should be capable of interfacing with the following ground systems:

- Air traffic management (ATM), including Integrated Initial Flight Plan Processing System (IFPS), departure management, etc.
- Approach surveillance system to take into account airborne aircraft;
- Stand management systems;
- Existing and future ATS systems;
- MET systems;
- Visual aids;
- Any other system as part of the Collaborative Decision Making Process (CDM).

Source: [ICAO A-SMGCS] 2.6.16.1

Op_If-5-Interference with ATC

The operation of A-SMGCS interfaces should not interfere with other ATC responsibilities.

Sources: [ICAO A-SMGCS] 2.6.15.1

Op_Range-1-Visibility conditions

A-SMGCS shall be capable of operating in all visibility conditions.

Source: [ICAO A-SMGCS] 2.2.3

Op_Range-2-Capacity

A-SMGCS shall be able to handle all traffic movements on their area of interest at any instant time.

Note: Since capacity is a site-specific parameter, the determination of the maximum number of aircraft on the manoeuvring area should be based on the assumed peak traffic at the aerodrome. Aerodromes continually strive to increase capacity and therefore the number of movements, and hence aircraft and vehicles will probably increase over time. The A-SMGCS capacity figure should be sufficient to cater for expansion of this nature and reviewed on a regular basis to ensure that it is sufficient.

Source: [ICAO A-SMGCS] 4.1.1.5

Op_Range-3-Aircraft/vehicle types 1

An A-SMGCS shall support operations involving all aircraft types and all vehicles types.

Source: [ICAO A-SMGCS] 2.6.2

Op_Range-4-Aircraft/vehicle types 2

An A-SMGCS shall be adaptable to cater for future aircraft types and vehicles types.

Source: [ICAO A-SMGCS] 2.6.2

Op_Range-5-Speeds and Orientation

The system shall be capable of supporting operations of aircraft/vehicles within the following parameters:

- Minimum and maximum speeds for aircraft on final approach, and runways;
- Minimum and maximum speeds for aircraft on taxiways;
- Minimum and maximum speeds for vehicles; and
- Any heading.

Source: [ICAO A-SMGCS] 2.6.4

Op_Range-6-Velocity

The A-SMGCS should be able to accommodate the following speeds determined to within +/- 2km/h (1 kt):

- a) 0 to 93 km/h (50 kt) for aircraft on straight taxiways;
- b) 0 to 36 km/h (20 kt) for aircraft on taxiway curves;
- c) 0 to 150 km/h (80 kt) for aircraft on runway exits;
- d) 0 to 460 km/h (250 knots) for aircraft on final approach, missed approach and runways;
- e) 0 to 150 km/h (80 kt) for vehicles on the movement area; and
- f) 0 to 20 km/h (10 kt) for aircraft and vehicles on stands and stand taxi lanes.

Source: [ICAO A-SMGCS] 4.1.1.8

Op_Resp-1-Users

Although the responsibilities and functions may vary, they shall be clearly defined for all users of A-SMGCS.

Source: [ICAO A-SMGCS] 2.3

Op_Resp-2-Assignment

An A-SMGCS shall be designed so that the responsibilities and functions may be assigned to the following:

- a) The automated system;
- b) Controllers;
- c) Pilots;
- d) Vehicle drivers;
- g) Airport authorities;
- h) System operators.

Note 1: The allocation of functions and/or responsibilities might differ depending on visibility condition, level of automation and level of implementation of an A-SMGCS. A different division of functions among the control personnel (e.g. between authorities

responsible for aerodrome movement control and apron management services) may also be necessary as a result of possible changes in procedures caused by automation.

Note 2: ATC will be responsible for the management and overall operation of the system. When certain functions will be delegated to automated elements of the system, responsibilities for the integrity and reliability of those functions lie with the service providers, certification authorities, manufacturers and software suppliers.

Note 3: When A-SMGCS is in operation, pilots remain responsible for the safety and control of aircraft.

Note 4: ATC controllers and pilots are the only critical decision makers. Their decisions are based on surveillance data which have a specified integrity.

Source: [ICAO A-SMGCS] 2.3

Op_Resp-3-A-SMGCS category

Airport authority shall be responsible for notifying the A-SMGCS category operating in its aerodrome and the procedures that may be applied.

10.3 Operational Requirements for Surveillance

Op_Mon-1-Equipment Status

The operational status of all A-SMGCS equipment shall be monitored by the system, and alerts shall be provided when the system must not be used for the intended operation.

Source: [ICAO A-SMGCS] 2.5.1.2

Op_Mon-2-Performance

Monitoring of the performance of an A-SMGCS should be provided such that operationally significant failures are detected and remedial action is initiated to restore the service or provide a reduced level of service.

Source: [ICAO A-SMGCS] 2.7.4.3

Op_Mon-3-Data

The A-SMGCS shall perform a continuous validation of data provided to the user and timely alert the user when the system must not be used for the intended operation.

Note: As an example when an aircraft/vehicle is still on his area of interest, the system shall continuously detect the aircraft/vehicle; otherwise the user shall be timely alerted.

Source: [ICAO A-SMGCS] 2.7.3.2

Op_Mon-4-Back-up

The system shall allow for a reversion to adequate back-up procedures if failures in excess of the operationally significant period occur.

Source: [ICAO A-SMGCS] 2.7.5.3

Op_Mon-5-System Failures

Operationally significant failures in the system shall be clearly indicated to the control authority and any affected user.

Source: [ICAO A-SMGCS] 2.7.5.3

Op_Mon-6-Failure Alerts

All critical elements of the system should be provided with audio and visual indication of failure given in a timely manner.

Source: [ICAO A-SMGCS] 2.6.9.3

Op_Perf-01-Probability of Detection

The probability that an actual aircraft, vehicle or obstacle is detected and reported at the output of the surveillance element of the A-SMGCS shall be 99.9% at minimum.

Note 1: The output of the surveillance element means at the output of the process which builds a comprehensive surveillance package after fusion of data provided by the different surveillance sensors.

Note 2: Some ATS providers request a Probability of Detection of at least 95%, while the Probability of Detection is 99% for a Primary Surveillance Radar, and 95% for a Surface Movement Radar. The value of 99.9% could be achieved by combining several surveillance sensors, e.g. cooperative surveillance sensors.

Sources: [ICAO A-SMGCS] 4.5.1, 3.4.1.4 [EUROCAE-MASPS] 3.2.3

Op_Perf-02-Probability of False Detection

The probability that anything other than an actual aircraft, vehicle or obstacle is detected and reported by the surveillance element of the A-SMGCS shall not exceed 10E-3 per reported target.

Note 1: The surveillance element means at the output of the process which builds a comprehensive surveillance package after fusion of data provided by the different surveillance sensors.

Note 2: Some ATS Providers request a Probability of False Detection less than 1%.

Sources: [ICAO A-SMGCS] 4.5.1, 3.4.1.4 [EUROCAE-MASPS] 3.2.3

Op_Perf-03-Probability of Identification

The probability that the correct identity of an aircraft, vehicle or obstacle is reported at the output of the surveillance element shall be 99.9% at minimum.

Note 1: The output of the surveillance element means at the output of the process which builds a comprehensive surveillance package after fusion of data provided by the different surveillance sensors.

Note 2: Some ATS providers request a Probability of Identification of at least 99% while the Probability of Identification required for Mode-S radars is 99.9%.

Sources: [ICAO A-SMGCS] 4.5.1, 3.4.1.4, [EUROCAE-MASPS] 3.2.3

Op_Perf-04-Probability of False Identification

The probability that the identity reported at the output of the surveillance element is not the correct identity of the actual aircraft, vehicle or obstacle shall not exceed 10E-3 per reported target.

Note 1: The output of the surveillance element means at the output of the process which builds a comprehensive surveillance package after fusion of data provided by the different surveillance sensors.

Note 2: The value of 10E-3 for Probability of False Identification is already requested by some ATS providers and accepted by manufacturers.

Sources: [ICAO A-SMGCS] 4.5.1, 3.4.1.4, [EUROCAE-MASPS] 3.2.3

Op_Perf-05-Position Accuracy

For the surveillance service, the allowable error in reported position shall be consistent with the requirements set by the control task of the controller: 12 m.

Note:

For Reported Position Accuracy (RPA), ICAO specification recommends a value of 7.5m ([ICAO-A-SMGCS] 4.2.3).

For [EUROCAE-MOPS], a value of 7.5m (95% level of confidence) is recommended.

For [EUROCAE-MASPS] 3.2.2.1, a value of 12m would be reasonable for the surveillance service. The argument leads to the need only to place an aircraft within the width of a taxiway, or at least to be able to determine unambiguously which of two parallel taxiways and aircraft is using. If we therefore consider a typical taxiway width of 24 m it would be reasonable to require an RPA for taxiing aircraft of 12 metres.

When the control service is also provided to the controller, [EUROCAE-MASPS] 3.2.3 and [ICAO-A-SMGCS] 4.3.3.1 agree to consider a value of 7.5 metres for RPA. This value is required by the control service and not the surveillance service. This figure seems to be a little more demanding than the performance of existing tracking and labelling systems, using SMR as a source (confirmed by BETA project).

To take into account the level distinction made by EUROCAE, we propose a value of 12 metres for RPA when the position is used by the surveillance service.

Sources: [ICAO A-SMGCS] 2.7.1.2, 4.2.3, [EUROCAE-MASPS] 3.2.3

Op_Perf-06-Position Resolution

The aircraft/vehicle position resolution shall be at least 1 m.

Sources: [EUROCAE-MASPS] 3.2.3

Op_Perf-07-Altitude Accuracy

Where airborne traffic participates in the A-SMGCS, the level of an aircraft when airborne shall be determined within ± 10 m.

Note: Justification has not been provided for the need of aircraft altitude for A-SMGCS and for the value of its accuracy. However, it has been decided to keep this requirement as such in the document because it is provided by ICAO. If no more information about this requirement is provided so far, the validation activity will determine the status of this requirement.

Sources: [ICAO A-SMGCS] 4.2.3

Op_Perf-08-Update rate

Where appropriate, the update rate of an A-SMGCS shall be consistent with the requirements set by the control task of the controller: 1s.

Note: [EUROCAE-MASPS] 3.2.3 and [ICAO-A-SMGCS] 4.2.5 require the update rate should be at least 1s. For example, in one second, an aircraft rolling at 10 knots covers a distance of 5 meters. A vehicle at 35 km/h will move of 10 metres. In that case, the position displayed to the controller can differ of 10 metres from the actual position before being updated with the new reported value. If we take the maximum speed of 50kts for aircraft on straight taxiways ([ICAO-A-SMGCS] 4.1.1.8), the displayed position can differ of 25 metres.

Sources: [ICAO A-SMGCS] 4.2.5, [EUROCAE-MASPS] 3.2.3

Op_Perf-09-Integrity

A-SMGCS shall preclude failures that result in erroneous data provided to the users.

Sources: [ICAO A-SMGCS] 2.7.3.1, [EUROCAE-MASPS] 3.1.1.1

Op_Perf-10-Availability

The availability of an A-SMGCS shall be sufficient to support the safe, orderly and expeditious flow of traffic on the movement area of an aerodrome.

Note: Some ATS providers require an availability of 95.5% per year, and unavailability less than 1 hour per day.

Sources: [ICAO A-SMGCS] 2.7.4.1, [EUROCAE-MASPS] 3.1.1.2

Op_Perf-11-Reliability

A failure of equipment shall not cause:

- A reduction in safety (fail soft); and
- The loss of basic functions.

Sources: [ICAO A-SMGCS] 2.7.5.2, [EUROCAE-MASPS] 3.1.1

Op_Perf-12-Continuity of Service 1

An A-SMGCS shall provide a continuous service.

Sources: [ICAO A-SMGCS] 2.7.4.2, [EUROCAE-MASPS] 3.1.1.2

Op_Perf-13-Continuity of Service 2

Any unscheduled break in continuity shall be sufficiently short or rare as not to affect the safety of aircraft/vehicles.

Sources: [ICAO A-SMGCS] 2.7.4.2, [EUROCAE-MASPS] 3.1.1.2

Op_Perf-14-Recovery time

When restarting, the recovery times of A-SMGCS shall be of a few seconds.

Source: [ICAO A-SMGCS] 2.6.9.4

Op_Perf-22-Detection of Obstacles

The A-SMGCS shall detect obstacles, whether moving or stationary, located anywhere on the movement area of the aerodrome and having an equivalent radar cross section of 1 square meter or more

Source: [ICAO SMGCS] annex F 4.2.1, [EUROCAE-MOPS] 3.2, 3.4.2

Op_Serv-01-Service

A-SMGCS shall provide the surveillance service to the users.

Op_Serv-02-User

The users of the surveillance service shall be all control authorities concerned in the manoeuvring area of the aerodrome.

Op_Serv-03-Airport Traffic Situation

The surveillance service shall continuously provide the following airport traffic situation:

- Traffic Information;
- Traffic context.

Op_Serv-04-Traffic information 1

The surveillance service shall continuously provide the following traffic information:

- Position of all vehicles on the area of interest for vehicles, including intruders;
- Identity of all cooperative vehicles on the area of interest for vehicles;
- Position of all relevant aircraft on the area of interest for aircraft, including intruders;
- Identity of all relevant aircraft on the area of interest for aircraft;
- History of the aircraft/vehicles position (e. g. the 3 last positions displayed).

Op_Serv-05-Traffic information 2

The traffic information may optionally include other information about traffic, such as:

- Vehicle type;
- Aircraft type;
- Aircraft gate;
- ...

Note: this is a local issue to be decided by the ATS provider.

Op_Serv-06-Area of interest for vehicles

The area of interest for vehicles shall be the manoeuvring area.

Op_Serv-07-Area of interest for aircraft

The area of interest for aircraft shall be the movement area, plus a volume around the runways for aircraft on approach to each landing runway direction, at such a distance that inbound aircraft can be integrated into an A-SMGCS operation and that aerodrome movements, including aircraft departures, relevant missed approaches or aircraft crossing the relevant active runways, can be managed.

Source: [ICAO A-SMGCS] 2.5.1.1, 2.5.1.4, 2.5.1.5

Op_Serv-11-Position

Each aircraft/vehicle shall be seen in the correct position with respect to the aerodrome layout and other traffic.

Note: It means for instance, if an aircraft/vehicle is on the runway, it must be seen on the runway and not outside the runway. The position accuracy is given in another requirement.

Op_Serv-12-Label

The surveillance service shall provide to the user the ability to manually put the right call sign in the label associated to a vehicle equipped with co-operative equipment used for different vehicles.

Op_Serv-13-Transition

A seamless transition should be provided between the surveillance for an A-SMGCS and the surveillance of traffic in the vicinity of an aerodrome.

Source: [ICAO A-SMGCS] 2.5.1.6

10.4 Operational Requirements for Control

All A-SMGCS performance and system monitoring operational requirements for surveillance service apply to A-SMGCS control service. The performance requirements presented in the following section are specific to the control service.

Op_Perf-15-Position Accuracy

The allowable error in reported position shall be consistent with the requirements set by the Control service: 7.5m when the position is used by the conflict / infringement detection process.

Note 1: The position accuracy could not be the same in all areas, depending on the conflict / infringement detection requirements.

Note 2: The required position accuracy may be specifically defined at each airport by the ATS authority on the basis of local safety analysis.

Source: [ICAO A-SMGCS] 2.7.1.2, 4.2.3, [EUROCAE-MASPS] 3.2.3.

Op_Perf-16-Reported Velocity Accuracy

The velocity shall be determined to the following accuracy:

- Speed: <5m/s
- Direction of movement: <10°.

Note:

For reported velocity accuracy, ICAO specification recommends the following values ([ICAO A-SMGCS] 4.1.1.8 and 4.1.1.10):

- Speed: +/- 1 Kt (0.5 m/s)
- Direction of movement: +/-1°.

According to the performance of existing tracking systems studied in other projects such as BETA, these values do not seem to be achievable.

Therefore, we recommend the values required by [EUROCAE-MASPS] 3.2.3: 5 m/s for speed and 10° for direction of movement.

Source: [EUROCAE-MASPS] 3.2.3, [ICAO A-SMGCS] 4.1.1.8 and 4.1.1.10

Op_Perf-17-Target Report Velocity Resolution

The target report velocity resolution shall be:

- Speed: 1m/s
- Direction of movement: 1.5°

Source: [EUROCAE-MASPS] 3.2.3

Op_Perf-18-Alert latency

The alert resulting of conflict / infringement detection shall be provided to the user well in advance within a specified time frame, to enable the appropriate remedial action with respect to:

- a) Conflict / infringement prediction;
- b) Conflict / infringement detection; and
- c) Conflict / infringement resolution.

Source: [ICAO A-SMGCS] 2.5.4.4

Op_Perf-19-Alert Continuity

The Conflict/Infringement Alert should be displayed continuously while the conflict is detected.

Source: [ICAO A-SMGCS] 3.4.5.14

Op_Perf-20-False alert number

The number of false alert shall be as low as possible to not disturb the user.

Source: [EUROCAE-MASPS] 3.3.2.2, 3.3.2.3

Op_Perf-21-Impact of false alert on safety

The false alerts shall not impact on the airport safety.

Op_Serv-15-User

The users of the A-SMGCS control service shall be all control authorities concerned in the manoeuvring area of the aerodrome.

Op_Serv-16-Conflicts/infringements on runway

The control service shall detect the conflicts/infringements on runway provided in annex.

Source: [ICAO A-SMGCS] 2.5.4.1, [ICAO A-SMGCS] 2.5.4.3

Op_Serv-17-Restricted area incursions

The control service shall detect the restricted area incursions caused by an aircraft and/or vehicles into an area such as closed TWY, ILS or MLS critical area, to be defined locally for each aerodrome.

Source: [ICAO A-SMGCS] 2.5.4.1, [ICAO A-SMGCS] 2.5.4.3

Op_Serv-18-Runway protection area

The runway protection area shall be composed of two boundaries: a ground boundary to detect the aircraft/vehicles on the surface, an air boundary to detect airborne aircraft.

Op_Serv-19-Ground boundary

The length of the ground boundary must at least include the runway strip. The width could be defined, and different, according to the meteorological conditions, e.g. non-LVP, LVP.

As an example based on today ILS holding positions:

- In Non-LVP: ground boundary defined by Cat I holding position
- In LVP: ground boundary defined by Cat II / III holding position

This ground boundary will be used for both prediction and alert stages.

Note: In order to avoid unnecessary predictions or alerts to the controllers, current systems wait until the aircraft/vehicle has crossed the boundary.

Subject to further development, if the runway protection is ensured by an algorithm which could predict that an aircraft/vehicle is able or not to stop before entering the protection area, i.e. the ground boundary, a prediction / alert could be generated before the aircraft/vehicle crosses the boundary.

Such algorithms, based on the speed and position of an aircraft/vehicle, may already exist but they have to be evaluated.

Op_Serv-20-Air boundary

The air boundary shall be defined as a flight time to threshold and would take into account the two stages of alert, prediction and alert, as well as the meteorological conditions:

- Non-LVP: Prediction around T1 = 30'', Alert around T2 = 15''
- LVP: Prediction around T1 = 45'', Alert around T2 = 30''

Note: These times should be configurable, depending upon optimisation at the aerodrome.

Source: [ICAO A-SMGCS] 3.4.5.12, 3.4.5.13

Op_Serv-21-Traffic Context Update

For the Conflict/Infringement detection, additional updated and correct traffic context information shall be provided to the system such as:

- Airport Configuration: runways in use, runways status, restricted areas...
- Applied procedures and working methods: LVP, multiple line-up.

Op_Serv-22-Alert

The control service shall alert the users in case of conflict/infringement detection.

Source: [ICAO A-SMGCS] 2.5.4.1

Op_Serv-27-Stages of alert

The control service shall provide 2 stages of alert:

Stage 1 alert is used to inform the controller that a situation which is potentially dangerous may occur, and he/she needs to be made aware of. According to the situation, the controller receiving a stage 1 alert may take a specific action to resolve the alert if needed. This is called Information step.

Stage 2 alert is used to inform the controller that a critical situation is developing which needs immediate action. This is called Alarm step.

Note: Controllers have different preferences, some of them want to be alerted only when the situation is critical (only stage 2 alerts), and others wish more anticipation (2 stages of alert). This is confirmed by the evaluations performed in the BETA project. As a consequence, some ATS providers may choose to have Alert only, and not use Prediction. The choice of having several stages of alerts presented to the controller, according to the conflict / infringement, should be left to the ATS providers.

Op_Serv-28-Alert priority

Priorities should be established so as to ensure system logic performs efficiently. Conflict alerting priorities should be as follows:

- a) Runway incursions.
- b) Restricted area incursions.

Source: [ICAO A-SMGCS] 3.4.5.10

Op_Serv-29-Adaptation to local procedures

In order to efficiently assist ATCO, the automated A-SMGCS control service shall be configurable to adapt to local ATC procedures and working methods.

Op_Serv-30-Traffic Information Update

For the Conflict/Infringement detection, additional updated and correct traffic information shall be provided to the system such as aircraft/vehicles velocity.

Op_Mon-09-Data

The A-SMGCS shall perform a continuous validation of data provided to the user and timely alert the user when the system must not be used for the intended operation.

Source: [ICAO A-SMGCS] 2.7.3.2

Op_Mon-10-Back-up

The system shall allow for a reversion to adequate back-up procedures if failures in excess of the operationally significant period occur.

Source: [ICAO A-SMGCS] 2.7.5.3

Op_Mon-11-System Failures

Operationally significant failures in the system shall be clearly indicated to any affected user.

Source: [ICAO A-SMGCS] 2.7.5.3, 2.7.4.4

Op_Mon-12-Failure Alerts

All critical elements of the system should be provided with audio and visual indication of failure given in a timely manner.

Source: [ICAO A-SMGCS] 2.6.9.3

Op_Perf-23-Position Resolution

The aircraft/vehicle position resolution shall be at least 1 m.

Sources: [EUROCAE-MASPS] 3.2.3

Op_Perf-24-Update rate

Where appropriate, the update rate of the reported aircraft/vehicle position shall be consistent with the requirements set by the task of the driver: approximately 1s.

Note: [EUROCAE-MASPS] 3.2.3 and [ICAO-A-SMGCS] 4.2.4 require the update rate should be at least 1s. For example, in one second, a vehicle at 35 km/h, will move of 10 metres. In that case, the position displayed to the user can differ of 10 metres from the actual position before being updated with the new reported value. If we take the maximum speed of 80kts for vehicles on the movement area ([ICAO-A-SMGCS] 4.2.4.2), the displayed position can differ of 40 metres.

Sources: [ICAO A-SMGCS] 2.7.2, [EUROCAE-MASPS] 3.2.3

Op_Perf-25-Integrity

A-SMGCS shall preclude failures that result in erroneous data provided to the users.

Sources: [ICAO A-SMGCS] 2.7.3.1, [EUROCAE-MASPS] 3.1.1.1

Op_Perf-26-Reliability

A failure of equipment shall not cause:

- A reduction in safety (fail soft); and
- The loss of basic functions.

Sources: [ICAO A-SMGCS] 2.7.5.2, [EUROCAE-MASPS] 3.1.1

Op_Perf-27-Continuity of Service 1

An A-SMGCS shall provide a continuous service.

Sources: [ICAO A-SMGCS] 2.7.4.2, [EUROCAE-MASPS] 3.1.1.2

Op_Perf-28-Continuity of Service 2

Any unscheduled break in continuity shall be sufficiently short or rare as not to affect the safety of aircraft/vehicles.

Sources: [ICAO A-SMGCS] 2.7.4.2, [EUROCAE-MASPS] 3.1.1.2

Op_Serv-26-Position

The vehicle shall be seen in the correct position with respect to the aerodrome layout.

Note: It means for instance, if an aircraft/vehicle is on the runway, it must be seen on the runway and not outside the runway. The position accuracy is given in another requirement.

10.5 Operational Requirements for Routing

Op_Ds-11-Failure

The routing maximum failure rate per hour shall not exceed:

- 1.5E-03 in visibility condition 1;
- 1.5E-04 in visibility condition 2;
- 3.0E-06 in visibility condition 3;
- 1.5E-06 in visibility condition 4.

Sources: [ICAO A-SMGCS] 4.3.1

Op_Perf-29-Time Processing

The time taken to process an initial route should not exceed 10 seconds. Reprocessing to account for tactical changes once the aircraft or vehicle is in motion should not exceed 1s.

Sources: [ICAO A-SMGCS] 4.3.2

Op_Perf-30-Timing and Distance Resolution

In the processing of optimised routes, the length of taxi distances should be computed to a resolution better than 10m, and timing to a resolution better than 1s.

Sources: [ICAO A-SMGCS] 4.3.3

Op_Serv-31-Routing Capability

Either manually or automatically, the routing function of an A-SMGCS should:

- a) Be able to designate a route for each aircraft or vehicle within the movement area;
- b) Allow for a change of destination at any time
- c) Allow for a change of a route
- d) Be capable of meeting the needs of dense traffic at complex aerodromes; and
- e) Not constrain the pilot's choice of a runway exit following the landing.

Sources: [ICAO A-SMGCS] 2.5.2.1

Op_Serv-32-Semi-Automatic Routing

In a semi-automatic mode, the routing function should also provide the control authority with advisory information on designated routes.

Sources: [ICAO A-SMGCS] 2.5.2.2

Op_Serv-33- Automatic Routing

In an automatic mode, the routing function should also:

- a) Assign routes; and
- b) Provide adequate information to enable manual intervention in the event of a failure or at the discretion of the control authority

Sources: [ICAO A-SMGCS] 2.5.2.3

Op_Serv-34- Route Assignment

When assigning routes, an A-SMGCS should:

- A) Minimise taxi distances in accordance with the most efficient operational configuration;
- b) Be interactive with the control function to minimise crossing conflicts
- c) Be responsive to operational changes (e.g. runway changes, routes closed for maintenance, and temporary hazards or obstacles.
- d) Use standardised terminology or symbology.
- e) Be capable of providing routes as and when required by authorised users; and
- f) Provide a means of validating routes.

Sources: [ICAO A-SMGCS] 2.5.2.4

Op_Serv-35- Provision of routing information

The routing function should be capable of providing routing information for aircraft and vehicles on the movement area and, when necessary, other areas used by vehicles.

Sources: [ICAO A-SMGCS] 3.4.2.2

Op_Serv-36- Routing Optimisation

The routing function should provide an optimised route for each participating aircraft and vehicle. It should consider the overall time for an aircraft or vehicle to complete the route in all visibility conditions.

Sources: [ICAO A-SMGCS] 3.4.2.3

Op_Serv-37- Surface Traffic Flow Optimisation

The routing function should optimise the traffic flow of aircraft and vehicle surface movements, including aircraft under tow, with respect to:

- a) Reducing delay – when planning a route, an effort should be made to permit an aircraft to meet its assigned take-off time or reach its allocated gate on time.
- b) Potential conflict; the wing-tip to wing-tip spacing between certain types of aircraft on parallel taxiways should be taken into account.
- c) Longitudinal spacing when visibility becomes a factor, including jet blast and propeller / rotor wash
- d) Obstructed, unavailable or temporarily closed parts of the movement area; and
- e) Taxi speeds (to reduce braking and acceleration, and fuel burn).

Sources: [ICAO A-SMGCS] 3.4.2.4

Op_Serv-38- Use of intermediate routing waypoints

The routing function should be able to handle predefined or user defined intermediate waypoints (e.g. routing through de-icing stations).

Sources: [ICAO A-SMGCS] 3.4.2.5

Op_Serv-39- Use of Alternative Routes

An alternative route should always be available on request.

Sources: [ICAO A-SMGCS] 3.4.2.6

Op_Serv-40- Route Modification / Cancellation

By human-initiated means, or as a result of a conflict, it should be possible to cancel or change an existing and used route. In the event that a route is cancelled, a new route to continue should be provided.

Sources: [ICAO A-SMGCS] 3.4.2.7

10.6 Operational Requirements for Guidance

Op_Perf-31-Timing and Distance Resolution

The overall response time of initiation of the guidance to verification that the correct route of information has been provided should not exceed 2 seconds.

Sources: [ICAO A-SMGCS] 4.4.1

Op_Perf-32-Reversion Time

The reversion time should be a maximum of 0.5s.

Sources: [ICAO A-SMGCS] 4.4.2

Op_Serv-42- Guidance Capability

The guidance function of an A-SMGCS should:

- a) Provide guidance necessary for any authorised movement and be available for all possible route selections;
- b) Provide clear indications to pilots and vehicle drivers to allow them to follow their assigned routes.
- c) Enable all pilots and vehicle drivers to maintain situational awareness of their positions on the assigned routes.
- d) Be capable of accepting a change of route at any time.
- e) Be capable of indicating routes and areas for that are either restricted or not available for use;
- f) Allow monitoring of the operational status of all guidance aids; and
- g) Provide on-line monitoring alerts where guidance aids are selectively switched in response to routing and control requirements.

Note: when visibility conditions permit a safe, orderly and expeditious flow of authorised movements, the guidance function will primarily be based on standardised ground visual aids. If expeditious flow is restricted due to reduced visibility, additional equipment or systems will be required to supplement visual aids in order to maintain flow rates.

Sources: [ICAO A-SMGCS] 2.5.3

Op_Mon-07-Equipment Status

The operational status of all guidance service equipment shall be monitored by the system, and alerts shall be provided when the system must not be used for the intended operation.

Source: [ICAO A-SMGCS] 2.5.3

Op_Mon-08-Performance

Monitoring of the performance of the guidance service should be provided such that operationally significant failures are detected and appropriate remedial action is initiated to restore the service or provide a reduced level of service.

Source: [ICAO A-SMGCS] 2.7.4.3

Op_Perf-33-Position Accuracy

For the guidance service, the allowable error in reported position shall be consistent with the requirements set by the task of the user: 12 m.

Note:

For the Guidance service the position accuracy does not need to be better than for surveillance service.

If the same equipment is used to provide the position both to the control and the guidance service, the position accuracy must be consistent with the Position Accuracy requirement set for the control service.

Sources: [ICAO A-SMGCS] 2.7.1.2, [EUROCAE-MASPS] 3.2.3

Op_Perf-34-Recovery time

When restarting, the recovery times of the guidance service shall be compatible with user operations (a value of 1 minute would be reasonable as a maximum).

Source: [ICAO A-SMGCS] 2.6.9.4

Op_Serv-43-User

The users of the guidance service shall be the vehicles drivers.

Op_Serv-44-Display Items

The guidance service of an A-SMGCS shall display the following items to the user:

- Vehicle position;
- Airport layout: geographical representation of various airport areas (TWY, RWY...);
- Reference points: holding points, stop bars (and other airfield lighting), RWY thresholds...;
- Fixed obstacles.
- Other vehicle information (heading...) if required by the user.

Op_Serv-45-Provision of Guidance

As a minimum, guidance should be provided on the airport movement area.

Sources: [ICAO A-SMGCS] 3.4.3.6

Op_Serv-46-Guidance Aids

Once a route has been assigned, the pilot or vehicle driver will require adequate information to follow that route. Guidance aids shall indicate where on the taxiway or apron the aircraft or vehicle can be manoeuvred safely. Switched centre line lights and/or addressable signs shall enable routes to be uniquely designated.

Sources: [ICAO A-SMGCS] 3.4.3.4

Op_Serv-47-Guidance / Visibility Conditions

- When visibility conditions permit a safe, orderly and expeditious flow of authorised movements, guidance function will primarily be based on standardised ground visual aids including lighting, markings and signage.
- When visibility conditions are sufficient for the pilot to taxi by visual guidance only, but the sole use of visual guidance restricts the expeditious flow of authorised movements, additional equipment or systems may be needed to support the guidance function.
- When visibility conditions are insufficient for the pilot or vehicle driver to taxi by visual guidance only, the aerodrome itself, as well as the aircraft manoeuvring on the movement area and authorised vehicles, should be appropriately equipped to comply with the guidance function (when operations in these visibility conditions are permitted).

Sources: [ICAO A-SMGCS] 3.4.3.1, 3.4.3.2, 3.4.3.3

11 ANNEX I

11.1 References

- [EUROCONTROL - D1] A-SMGCS Project Strategy, Version 1.0, Edition 30th of September 2003
- [EUROCONTROL - D2] Definition of A-SMGCS Implementation Levels, Version 1.0, Edition 30th of September 2003
- [EUROCONTROL - D3] A-SMGCS Level I Operational Concept and Requirements, Version 1.0, Edition 30th of September 2003
- [EUROCONTROL – D4] A-SMGCS Level II Operational Concept and Requirements, Version 1.0, Edition 17th of May 2004
- [EUROCONTROL – D5] Functional Specification for A-SMGCS Implementation Level 1, Edition 30th of September 2003
- [EUROCONTROL – D6] Functional Specification for A-SMGCS Implementation Level 2, Version 1.0, Edition 17th of May 2004
- [EUROCONTROL - PROC] A-SMGCS Operating Procedures, Version 0.0x, Edition xxxx
- [ICAO-SMGCS] ICAO Manual of Surface Movement Guidance and Control Systems (SMGCS) doc 9476-AN/927 First Edition 1986
- [ICAO-A-SMGCS] Advanced Surface Movement Guidance and Control Systems (A-SMGCS) Manual (Doc 9830), First edition, July 2004
- [ICAO-Annex14] ICAO Annex 14, Volume I, Chapter 8
- [ICAO-4444] ICAO PANS ATM Doc 4444-RAC/501 RULES OF THE AIR AND AIR TRAFFIC SERVICES
- [ICAO-7030] ICAO Doc 7030- European Supplementary Procedures
- [EUROCAE-MASPS] EUROCAE WG-41, MASPS for A-SMGCS, Edition ED-87A, January 2001
- [EUROCAE-MOPS] MOPS for SMR sensor systems for use in A-SMGCS, ED-116, January 2004
- [EMMA] D131u OSED-update, www.dlr.de/emma

11.2 List of Figures

Figure 1-1: D1.3.5u ORD related to other EMMA concept documents.....	8
Figure 1-2: Logical order for the Implementation of A-SMGCS Service Steps	10
Figure 10-1 : Service level	90
Figure 10-2 : Functional level	91
Figure 10-3 : Architectural level	91

12 ANNEX II: DOC 4444: A-SMGCS Additional Phraseology

Proposals for amendments to ICAO Phraseologies in Chapter 12 of Doc. 4444 (i.e. inclusion of note referring to the need to identify traffic).

12.3.4.4 PUSH-BACK PROCEDURES

Note 1: When local procedures so prescribe, authorisation for pushback should be obtained from the control tower.

NEW: Note2: When an A-SMGCS surveillance tool is used to determine the aircraft position on the ground prior to transmit an ATC clearance to the crew, an identification procedure should be performed.

12.3.4.5 TOWING PROCEDURES

NEW: Note1: When an A-SMGCS surveillance tool is used to determine the aircraft position on the ground prior to transmit an ATC clearance to his crew, an identification procedure should be performed.

12.3.4.7 TAXI PROCEDURES

NEW: Note1: When an A-SMGCS surveillance tool is used to determine the aircraft position on the ground prior to transmit an ATC clearance to his crew, an identification procedure should be performed.

12.3.4.9 TO CROSS A RUNWAY

*a) REQUEST CROSS RUNWAY (*number*);

Note1: If the control tower is unable to see the crossing aircraft (e.g. night, low visibility, etc.), the instruction should always be accompanied by a request to report when the aircraft has vacated and is clear of the runway.

NEW: Note 2: When an A-SMGCS surveillance tool is used to determine the aircraft position on the ground, the clearance to cross the runway and the confirmation that the runway is vacated will be based on the information provided on the surveillance display.

13 ANNEX III: Samples of messages (control function)

Reference Aircraft	Conflicting aircraft/vehicle	Information	Alarm
No Reference aircraft	Unidentified vehicle on the runway protection area	No	Yes
	Aircraft proceeding to a closed runway	aircraft on runway protection area surface	Departing aircraft lining-up or taking-off STOP IMMEDIATELY or CANCEL TAKE OFF or arriving aircraft (< T1 from threshold) GO AROUND
	Aircraft departing on the runway in the wrong direction	No	Yes CANCEL TAKE OFF
Arriving aircraft	an aircraft or vehicle is on the runway protection area surface	arriving aircraft < T1 from threshold	the arriving aircraft < T2 from threshold, until the arriving aircraft has passed the aircraft/vehicle (aircraft/vehicle behind the arriving aircraft) GO AROUND
	a slower preceding departing aircraft which has not crossed the end of the runway-in-use or has not started a turn	arriving aircraft < T1 from threshold	Arriving aircraft < T2 from threshold (???? IF AIRBORNE?)
	a preceding arriving aircraft which has not cleared the <u>protection area</u>	arriving aircraft < T1 from threshold	Arriving aircraft < T2 from threshold GO AROUND if no reduced separation on the same runway.
Departing aircraft	an aircraft or vehicle is on the runway protection area surface and not behind the departing aircraft	departing aircraft is not yet taking-off (speed < 50 knots)	departing aircraft is taking-off (speed > 50 knots)



END OF DOCUMENT