



# University of HUDDERSFIELD

## University of Huddersfield Repository

Shagluf, Abubaker, Longstaff, Andrew P. and Fletcher, Simon

A Preliminary Study of Applying Lean Six Sigma Methods to Machine Tool Measurement

### Original Citation

Shagluf, Abubaker, Longstaff, Andrew P. and Fletcher, Simon (2015) A Preliminary Study of Applying Lean Six Sigma Methods to Machine Tool Measurement. In: Second International Conference on Sustainable Design and Manufacturing, 12th-14th April 2015, Seville, Spain.

This version is available at <http://eprints.hud.ac.uk/24342/>

The University Repository is a digital collection of the research output of the University, available on Open Access. Copyright and Moral Rights for the items on this site are retained by the individual author and/or other copyright owners. Users may access full items free of charge; copies of full text items generally can be reproduced, displayed or performed and given to third parties in any format or medium for personal research or study, educational or not-for-profit purposes without prior permission or charge, provided:

- The authors, title and full bibliographic details is credited in any copy;
- A hyperlink and/or URL is included for the original metadata page; and
- The content is not changed in any way.

For more information, including our policy and submission procedure, please contact the Repository Team at: [E.mailbox@hud.ac.uk](mailto:E.mailbox@hud.ac.uk).

<http://eprints.hud.ac.uk/>

# A Preliminary Study of Applying Lean Six Sigma Methods to Machine Tool Measurement

Abubaker Shagluf<sup>1</sup>, Andrew P. Longstaff<sup>2</sup>, Simon Fletcher<sup>3</sup>

Centre for Precision Technologies, University of Huddersfield  
Huddersfield, United Kingdom

[1abubaker.shagluf@hud.ac.uk](mailto:abubaker.shagluf@hud.ac.uk), [2a.p.longstaff@hud.ac.uk](mailto:a.p.longstaff@hud.ac.uk), [3s.fletcher@hud.ac.uk](mailto:s.fletcher@hud.ac.uk)

**Abstract** *Many manufacturers aim to increase their levels of high-quality production in order to improve their market competitiveness. Continuous improvement of maintenance strategies is a key factor to be capable of delivering high quality products and services on-time with minimal operating costs. However, the cost of maintaining quality is often perceived as a non-added-value task. Improving the efficiency and effectiveness of the measurement procedures necessary to guarantee accuracy of production is a more complex task than many other maintenance functions and so deserves particular analysis.*

*This paper investigates the feasibility of producing a concise yet effective framework that will provide a preliminary approach for integrating Lean and Six Sigma philosophies to the specific goal of reducing unnecessary downtime on manufacturing machines while maintaining its ability to machine to the required tolerance.*

*The purpose of this study is to show how a Six Sigma infrastructure is used to investigate the root causes of complication occurring during the machine tool measurement. This work recognises issues of the uncertainty of data, and the measurement procedures in parallel with the main tools of Six Sigma's Define-Measure-Analyse-Improve-Control (DMAIC).*

*The significance of this work is that machine tool accuracy is critical for high value manufacturing. Over-measuring the machine to ensure accuracy potentially reduces production volume. However, not measuring them or ignoring accuracy aspects possibly lead to production waste. This piece of work aims to present a lean guidance to lessen measurement uncertainties and optimise the machine tool benchmarking procedures, while adopting the DMAIC strategy to reduce unnecessary downtime.*

## **1. Introduction**

As industrial competition grows, more emphasis has been placed on both maintenance and, in particular, error mapping techniques for manufacturing machines. This is due to an ever-growing need for tighter tolerances on manufactured components and machine tools that can more reliably achieve them [1]. Recently, management strategies that support calibration are seen as tools for minimising manufacturing waste and reducing downtime [2]. This has led to studies that look into the implementation of different calibration strategies according to different scenarios [3]. Quality is one of the most important factors for achieving competitive advantage by adding value to a product [4]. As a result, quality management theory is increasingly adopted in industry for improving competitiveness and financial results. For instance, total quality management (TQM) has been a popular method within industries for several years. It refers to management methods used to enhance quality and productivity in organisations, particularly manufacturing industries. Its goal is continuously improving organisations' abilities to deliver high quality products and services to customers, thus meeting their requirements [5].

The evolution of other quality management methods, such as Lean Enterprise and Six Sigma ( $6\sigma$ ), has given the manufacturing industry options for selecting the most suitable strategy to meet their needs. Consequently, the right balance between each of these philosophies, allowing more flexibility to the users and their integration, continues to develop towards improving overall effectiveness [6]. This paper presents a discussion of the basics of the  $6\sigma$  and "Lean" improvement methodologies and then it provides a combined model of L $6\sigma$  to make use of their concepts, effects, similarities, and differences.

## **2. Six Sigma ( $6\sigma$ )**

Six sigma is focused on quality. It aims to reduce process variation to improve output. It is a method that values analytical studies and requires that decisions are data-driven. It seeks to eliminate all unnecessary steps from a company's processes.  $6\sigma$  provides a structured approach to solving problems through the implementation of five phases; Define, Measure, Analyse, Improve and Control (DMAIC). It is envisaged that it is comprehensive and understandable for all contributors in the process and is sufficiently generic that it can be globally applicable. It has been selected as a possible solution to the machine measurement problem since it purports to increase overall equipment effectiveness

(OEE) of the technical systems, which ultimately leads to a greater profit for the business [7].

Applying 6 $\sigma$  to maintenance follows a standard method for a program: focus on the process and engage workers. Engaging the people who best understand the process includes both the maintenance personnel and the shop-floor operators. Operators who run the machines are a key resource for achieving higher machine uptime and overall effectiveness since they are often the first-line or on-the-spot decision-makers when remedial action is required. It is commonly assumed that such preventive management techniques work better in large companies, especially those engaged in mass production [8]. The philosophy is more difficult to apply in small companies where the investment cost of implementation is difficult to justify, even though it might eventually lead to a reduction in lost revenues and overall downtime costs [9]. The approach can be used in maintenance to eliminate variations or defects in processes or address problems using statistical analysis (e.g., optimising the use of metrology equipment and the fixtures needed to aid the process of measuring a machine tool). 6 $\sigma$  develops standard work to document the proper way to perform a measurement task and make it easy for maintenance personnel to do the task correctly. This is also beneficial for new workers to efficiently undertake their new duties by following process maps, flow charts and diagrams. Developing maintenance work following the DMAIC structure with the workers who actually use it, evaluating it in the shop floor, improving the documented practices over time, and reviewing it in regular basis are some best practices for standard work [10].

### **3. Lean thinking**

Lean, sometimes called “lean manufacturing,” “lean production” or “lean enterprise,” is focused on eliminating waste, which is defined as “anything not necessary to produce the product or service” [11]. Waste reduction is often in terms of reducing the unnecessary steps to complete a task. Lean flow thinking challenges people’s identified roles within the manufacturing process and their relationship to the product and service. As a result, organisational changes are made with the intention of improving flow time.

Although Lean is for production, and there is no product in the machine measurement application, the principles can still be applied to improve the efficiency of machine tool measurement. Lean philosophy can reduce unnecessary measuring both in terms of parameters to be quantified and the frequency with which this is performed. This means processing too soon or too much (e.g.,

multiple forms of testing with same information and results). Waiting process wastes could be eliminated by Lean too (e.g., employees waiting for equipment downtime). Transportation or movements of items more than required or 'motion' movement of people or machinery that does not add value could be reduced by Lean notion. Wastes of excess processing by doing more work or process than is required (e.g., data re-entry, unused reports and multiple approvals etc.) could also be eliminated by Lean management.

#### 4. Lean Six Sigma (L6σ)

From this discussion, Lean and Six Sigma are organisational improvement programs which differ in approach and in their ultimate aims. Lean focuses on waste and 6σ targets process variations. Table 1 summarises the basics of these methodologies, while the essential application guidelines of both are presented in Table 2. The aims of these philosophies are potentially conflicting.

Program	Six Sigma DMAIC	Lean
<b>Objective</b>	Deliver value to customer	Deliver value to customer
<b>Theory</b>	Reduce variation	Reduce waste
<b>Focus</b>	Problem focused	Flow or process focused
<b>Assumptions</b>	System output improves if variation in all processes inputs is reduced	Waste removal will improve overall effectiveness.

**Table 1 L&6σ concepts**

Program	Six Sigma DMAIC	Lean
<b>Application guidelines</b>	-Define -Measure -Analyse -Improve -Control	-Specify Value -Identify the steps in the value stream -Create smooth flow -Customer pulls value (Produce what is ready to be consumed by the customer) -Pursue target (improve the process each time to achieve their requirements in as within tolerance as possible)

**Table 2 L&6σ improvement programs guidelines**

L6σ is a combination of the two techniques. It is an improvement methodology whose roots are in both manufacturing and service industries. It developed over the past few decades [12] with the aim of improving quality, speed and customer satisfaction, with the focus on cost-reduction in production. The concept behind the

L6 $\sigma$  approach achieves its notion by merging tools and principles of both Lean and 6 $\sigma$ . It combines the two foundations of the improvement engines; Lean provides mechanisms for quickly and dramatically reducing lead times and waste in any process, anywhere in an organisation and 6 $\sigma$  provides the tools and organisational guidelines that establish a data-driven foundation for sustained improvement in customer-critical targets [10].

L6 $\sigma$  is a guide to cut costs, reduce waste and to doing more with less [12]. Moreover, process speed and agility can directly enable true competitive advantage. In this paper we address the concept of how to improve measurement efficiency, which reduces waste in order to optimise the application of machine tool measurement process. Fewer setup steps and measurement process at any given moment means quicker response time to changes of the test requirements. A point of conflict between the two philosophies of 6 $\sigma$  and Lean is reducing the measurement process flexibility as a method of improving quality might increase the number of unnecessary step (waste). Furthermore, reducing the frequency of data collection, or the parameters measured might meet the targets for Lean manufacturing, but without careful consideration can have a significant detrimental impact on the decision-making foundations for the 6 $\sigma$  process. Careful balance or optimisation in this situation is required. For example, there is a trade-off between choosing whether to follow a fixed process of a fixed period of regular machine tool calibration (6 $\sigma$ ) or allowing variability to reduce non-value-added measurements to meet the requirements of Lean. If a machine is measured periodically for a long period of time without any change then it implies that some of these measurements were unnecessary. Applying the 6 $\sigma$  data driven approach can allow the frequency of measurement to be adjusted to better fit a Lean concept. A major obstacle to the adoption of the proposed improvement methodologies is the cost associated with such techniques, especially when compared to the uncertainties around their efficacy. Satisfactory results of implementing these techniques require time and commitment to the process. According to George [12] the slow rate of corporate improvement is not due to lack of knowledge of 6 $\sigma$  or Lean. Rather, the fault lies in making the transition from theory to implementation. Managers need a step-by-step, unambiguous roadmap of improvement that leads to predictable results.

## **5. Maintenance Process Selection**

Selection of the maintenance strategy to benchmark a sufficiently accurate, productive machine tool is as important as the choice of the proper tools and metrology equipment used for this task. Many maintenance departments continue to waste time, effort, and budgets over-engineering their maintenance processes,

without realising the cost consequences [12]. They focus on tasks that do not add value for their company, customer or the business. The primary objective of this paper is to provide a preliminary approach for applying L6 $\sigma$  philosophy to reduce downtime for unnecessary measurements while still maintaining the machine at the required accuracy specification. A list of definitions that need to be achieved for the successful completion of this work is given in Table 3.

<b>Aspect</b>	<b>Definition</b>
<b>Accuracy</b>	The closeness of agreement between a test results and the accepted reference value [13]
<b>Precision</b>	The closeness of agreement between independent test results obtained under stipulated conditions [13]
<b>Tolerance</b>	The permissible errors of the machine tool characteristic and geometric accuracy parameters being evaluated and shall be specified in accordance with functional requirements [14]
<b>Traceability</b>	Property of a measurement result whereby the result can be related to a reference through a documented unbroken chain of calibrations, each contributing to the measurement uncertainty [15]

**Table 3 Some important aspects when carrying out measurement**

This work focused on how to produce rapid yet traceable procedures. Improving the method of benchmarking machine tool accuracy performance requires making changes to the way the process is carried out. A rigorous analysis of the process is conducted by the maintenance team, in conjunction with the quality and manufacturing engineers. The work presented follows the structure of DMAIC and uses L6 $\sigma$  tools and thinking to uncover what needs to be changed, innovate improvements and work with the maintenance team to implement them.

## **6. Lean Six Sigma approach to machine tool accuracy monitoring**

This paper proposes that the Lean Six Sigma (L6 $\sigma$ ) approach can provide a generic method to improve the specific problem of machine tool measurement. Machine tool error mapping consists of quantifying the different degrees of freedom for the machine tool axes and their interrelationship errors. These have been well defined in various pieces of error modelling research [16]. The steps to achieve this, following the DMAIC structure, are as follows:

**Define** the problem, which in this application is “efficient machine tool measurement.” This means controlling machine tool accuracy to a known standard. The determination of which machine is to be controlled, and to what required accuracy, should be specified at this stage. This definition of measurements then

cascades down to its smallest constituent part since each required measurement must also be defined in terms of its purpose and value. In this case, the reason for the test being carried out, with respect to the relationship between the cutting tool and work piece, is the focus of the definition. The value of each measurement is expressed in terms of how a specific error component for a particular machine at a specific time could be a fully quantified in a certain period of time. This step can improve quality by providing the coverage of error measurement for all necessary components, and can reduce waste by defining the requirement to be only measuring those components that affect the final work-piece.

**Measure** the second step is specifying the measurement process of how to measure, how often to measure, what metrology equipment and method to use. This can be made lean by planning identified measurement steps according to standards and by optimising the order of tasks to improve quality and reduce downtime, such as using Artificial Intelligence (AI) planning [17]. At this stage, measurements resulting in action should be identified. The measure step is also about developing a data collection plan and performing it in such a way that it can be used to analyse the data in a meaningful way.

Successful measurement depends on accurate metrology systems (equipment and software) that are traceability to international standards, an understanding and minimisation of uncertainty and an application of good measurement practice. However, this is where potential conflict can arise; minimising downtime might increase uncertainty, which is to say reduce data quality. Manufacturing industries need their production machine tools to be measured quickly. However, quick checks can cause inaccuracy if they are not well performed. Measurements should be reliable in identifying the dimensions of concern to the degree of accuracy required and should be sufficiently robust to eliminate false positives. Measurements should be conducted in accordance with standard procedures. These could be according to international (ISO), national, company or original equipment manufacturer (OEM) standards to allow the ease of traceability of the test method. This will enable test reproducibility for different users and improve efficiency; it ensures that the approach taken is sustainable.

**Analyse** it is essential not to jump to “improve” before identifying the root cause of the problem, ensuring that the uncertainties of the measurement (equipment, personnel, frequency, etc.) are sufficiently small to be able to make good judgement. The maintenance technicians should be given full training in order to eliminate any false readings or misinterpretation and therefore false reaction. Machine operators should be suitably informed of the reasons that maintenance



technicians are performing measurement tasks on their machines so that they can provide support evidence for any root cause analysis [9]. In reality, without good management, there is a high probability that some calibration or maintenance intervention is based on wrong analysis of data. Analysing the results from a machine tool test requires a holistic review of all available data and how they can be influenced by the myriad different scenarios. Experience and a theoretical knowledge are both essential in order to interpret data correctly and not be misled by a single piece of data in isolation.

A commonly encountered mistake in modern manufacturing is the compensation of linear axis errors based upon a single linear positioning measurement. Data captured by a high-value laser interferometer is fed back into the CNC controller to modify the positioning behaviour. However, all too often, the cause of the linear error is a combination of laser misalignment, environmental temperature, machine heating, magnification of an angular error (Abbé error), etc. This means that the problem is partially rectified for a single position of the machine at a single instant in time, rather than considering the overall machine requirement. The problem is not rectified, leading to further waste when more measurement activity is later required.

Measurement data is only valuable when accompanied by a statement of its uncertainty. The uncertainty of measurement includes the uncertainty of the measuring technique, the measuring device and the personnel. Without a proper method of test, the uncertainty of results could be as high when using a high accuracy device as with a low-cost unit. The use of a double Ballbar to measure the machine can serve as a good example. It is often used for process monitoring since its ease of use means it can be efficiently run by a machine tool operator, so does not require additional expensive specialist labour. However, this very fact means that such a system might not be treated in the same way as a granite artefact and indicator clock; the perception is that since it is relatively robust and does not require a trained metrologist it can be handled with less care. As a result, what could be a very useful Lean tool to improve process flow can introduce waste due to unreliable measurements. Similarly, some maintenance workers keep dial/digital test indicators, able to measure with micron resolution, unprotected in their tool boxes alongside spanners and screw drivers. In this situation the device can become damaged without apparent external signs so no subsequent measurement could be relied upon [9]. L6 $\sigma$  role in this stage is applied by the raising awareness of the effects of such bad practice and eliminating them to ensure: careful set-up, mounting of metrology equipment, stability of element under test, clear measurement steps (repeatability), cleanliness and good condition of

equipment, eliminating unwanted effects, and keeping good records of regular inspections as references. Figure 1 shows a Ballbar machine tool measurement for a three axis machine, which was run under different test conditions. The table load and height at which the test took a place is different in each case, representing the situation where a new machine is tested, and then a semi-permanent fixture is used during production. What might, without good documentation of the test, appear to be a sudden change in machine behaviour, can be attributed to the different mass or, as in this case, an angular effect on the machine.

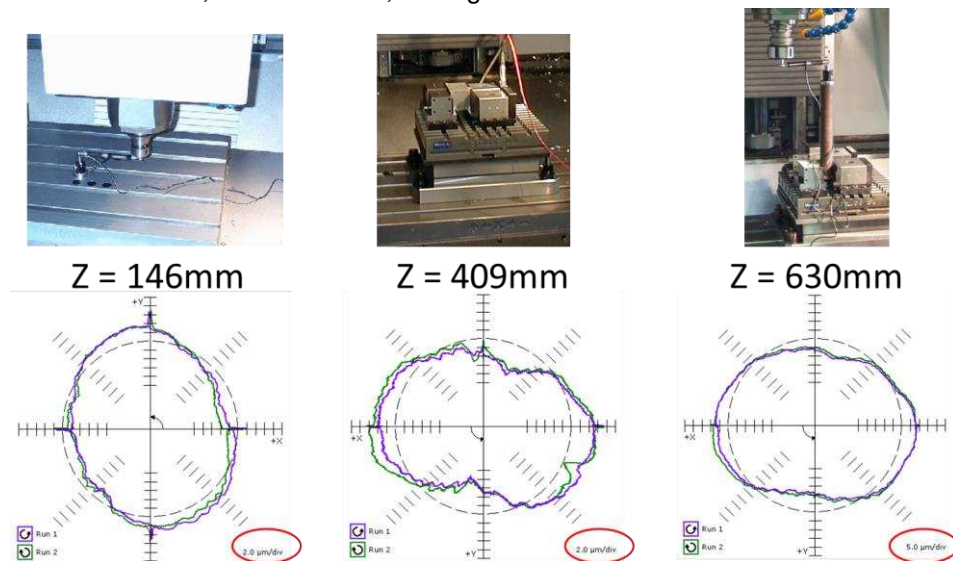

**Figure 1 Ballbar measurements under different test conditions**

It may seem trivial, but a commonly encountered mistake in analysing trend behaviour from graphs comes from ignoring the scaling. For instance, the rightmost chart in Figure 1 appears to have better form than the middle one. However, the scale is 5μ/div compared to 2μ/div respectively. It might appear trivial, but forcing analysis using a common scaling is a simple way of reducing false interpretation of data in this form.

**Improving** the process is achieved by taking the data from the previous steps and identifying and rectifying the gaps in the method that will reduce the variation in the measurement process. However, variations must be tackled with clear continuous steps of lean perspective as well as 6σ so that it creates a balance between the targets of the two methodologies' individuals and does not create more waste. With experience, Standard Operating Procedure (SOPs) can be modified to make them more efficient. Additionally, new tools become available through new products from

metrology equipment suppliers. Such changes must be done in a controlled, rather than *ad hoc*, way and are essential, since identified efficiencies must become part of the reproducible methodology. Without these processes in place, maintenance workers waste time and effort on reinventing methods of test and, without full knowledge of the purpose of the measurement, can erroneously reduce its worth. Continuous improvement is a further tool required to identify and eliminate causes of problems such as equipment failures and lack of required resources and tools. Reducing or eliminating these issues will produce increased quality and rapid measurement, reduce risks, increase equipment reliability, and reduce maintenance and operating costs. Moreover, the maintenance department is part of manufactory system as a whole. Communication and holistic thinking is encouraged by L6 $\sigma$  to provide successful results. Maintenance services needs the right personnel, tools, information and spare parts at the right time and place with clear maintenance policies. Successful industries are the ones manage to address good relationships between maintenance and other areas such as operations and training resources.

**Control** is about pursuing sustainability in the implementation of the process through a robust monitoring plan. Controlling all the elements mentioned, follows L6 $\sigma$  and fits into their categories assigned in Table 2. This can be achieved by ensuring that all captured data is self-checked and self-verifiable. At present, this is very difficult since the machine tool measurement problem is solved by using a number of disparate pieces of equipment from a variety of suppliers, using non-bespoke software. A true L6 $\sigma$  approach needs this to be addressed by provision of a single interface to analyse the data.

## **7. Discussion and conclusion**

Optimum maintenance and calibration management is highly desirable for manufacturing organisations, in particular from machine tool users who are subject to a high degree of accuracy. Maintenance should be understood as a way of enhancing the competitive advantage of a manufacturer and should not be considered a cost driving necessity. Companies competing in a complex global marketplace face enormous pressure to maintain operational excellence. Applying Lean Six Sigma (L6 $\sigma$ ), the quality management methodology used to reduce waste, eliminate product defects and improve customer satisfaction, involves focusing on machine tool maintenance and error-mapping strategies in order to meet that challenge. Transforming maintenance procedures to utilize more efficient processes depends on producing records using adequately trained personnel and traceable equipment. This indicates that applying L6 $\sigma$  techniques could be

beneficial not only to a company's manufacturing operations but also to their maintenance department's service and other industrial functions. It is envisaged that Lean alone is insufficient to achieve manufacturing companies' aims and thus has to be combined with other tools such as 6 $\sigma$  etc. This belief might be either due to the lack of understanding of the method or an inherent fault lies in making the transition from theory to implementation the paradigm. Because it is a measurement then natural response is to apply 6 $\sigma$ , which is recognised as a quality paradigm. However, because it is a manufacturing process then Lean method maybe preferred. Regular measurement of a machine to a define schedule would meet the need of 6 $\sigma$ . However, for a relatively stable machine this could lead to many unnecessary interruptions to production. Applying a L6 $\sigma$  approach, allows changing condition to drive regularity of measurement.

This paper has shown the feasibility of producing a concise, yet effective framework that provides a preliminary approach for integrating L6 $\sigma$  to reduce unnecessary downtime for error-mapping while maintaining the machine at the required tolerance. Lean is a generic series of tools to eliminate waste in manufacturing or service industry, while 6 $\sigma$  is a data driven philosophy and process resulting in an improvement in product and service quality and customer satisfaction. This paper provides a real-world example from a situation where the critical determinants of quality and speed are the flow of information and the interaction between maintenance workers. Implementing the L6 $\sigma$  methodology in machine tool measurement has resulted in significant quality and speed benefits, and would result in more benefits for production processes such as reduced re-tooling or rework, reduced scrap, and valuable time saving. This illustrates that good management can convert a perceived non-value-added measurement task into a positive impact.

## **8. Acknowledgement**

The authors gratefully acknowledge the UK's Engineering and Physical Sciences Research Council (EPSRC) funding of the EPSRC Centre for Innovative Manufacturing in Advanced Metrology (Grant Ref: EP/I033424/1). The work is also partially supported by the European Commission project EASE-R3 (Grant Ref 608771/FP7-2013-NMP-ICT-FoF), for which the authors express their gratitude.

## **References**

- [1] I. P. S. Ahuja and J. S. Khamba, "Total productive maintenance: literature review and directions," *International Journal of Quality & Reliability Management*, vol. 25, pp. 709-756, 2008.

- [2] P. Willoughby, M. Verma, A. P. Longstaff, S. Fletcher,, "A Holistic Approach to Quantifying and Controlling the Accuracy, Performance and Availability of Machine Tools," ed: Springer, 2010.
- [3] A. Shagluf, S. Parkinson, A. P. Longstaff, S. Fletcher, , "Towards an Optimization Calculation for Preventative and Reactive Calibration Strategies," presented at the Sustainable Design and Manufacturing 2014, SDM-14., Cardiff, Wales, UK., 2014.
- [4] V. B. Andrea Ionica, Eduard Edelhauser, Sabina Irimie, "TQM and Business Excellence.pdf," *Annals of the University of Petrosani, Economics*, vol. 10(4), pp. 125-134, 2010.
- [5] J. S. Oakland, *Total Quality Management*, Second ed. Oxford: Butterworth-Heinemann, 1993.
- [6] B. Klefsjo and B. Bergquist, "Six Sigma and Total Quality Management Different Day Same Soup," *International Journal for Six Sigma and competitive Advantage*, pp. 162-178.
- [7] M. Pedja and Klaus Rall, "Six Sigma concept in the maintenance process of technical systems," *Mechanical Engineering*, vol. 3, pp. 93-108, 2005.
- [8] D. McCarthy and N. Rich, *Lean TPM: a blueprint for change*. Amsterdam; London: Elsevier Butterworth-Heinemann, 2004.
- [9] A. Shagluf, A. P. Longstaff, S. Fletcher, "Maintenance Strategies to Reduce Downtime Due to Machine Positional Errors," presented at the Maintenance Performance Measurement and Management Conference Coimbra, Portugal, 2014.
- [10] M. George, *Lean Six Sigma for Service: How to Use Lean Speed and Six Sigma Quality to Improve Services and Transactions*: McGraw-Hill Education, 2003.
- [11] D. Nave, "How to compare six sigma, lean and the theory of constraints," *Quality Progress*, pp. 73-78, March 2002.
- [12] M. George, *The lean six sigma guide to doing more with less: cut costs, reduce waste, and lower your overhead*. Hoboken, NJ: Wiley, 2010.
- [13] "BS ISO 5725-1:1994: Accuracy (trueness and precision) of measurement methods and results. General principles and definitions," ed: British Standards Institute, 1995.
- [14] "BS ISO 230-1:1996: Test code for machine tools. Geometric accuracy of machines operating under no-load or finishing conditions," ed: British Standards Institute, 1997.
- [15] International Organisation for Standardization, "International vocabulary of metrology-Basic and general concepts and associated terms (VIM)," J. m. organisations, Ed., 3rd edition ed: JCGM member organisations, 2008, p. 104.
- [16] A. P. Longstaff, S. Fletcher, A. Poxton, A. Myres, "Comparison of Volumetric Analysis Methods for Machine Tools with Rotary Axes," ed: Euspen Ltd, 2009.
- [17] S. Parkinson, A. P. Longstaff, S. Fletcher, S. Crampton, A. Gregory, P., "Automatic planning for machine tool calibration: A case study," *Expert Systems With Applications*, vol. 39, p. 11367, 2012.