



University of HUDDERSFIELD

University of Huddersfield Repository

Wang, Ruichen, Chen, Zhi, Xun, Haijun, Schmidt, Karsten, Gu, Fengshou and Ball, Andrew

Modelling and Validation of a Regenerative Shock Absorber System

Original Citation

Wang, Ruichen, Chen, Zhi, Xun, Haijun, Schmidt, Karsten, Gu, Fengshou and Ball, Andrew (2014) Modelling and Validation of a Regenerative Shock Absorber System. In: The 20th International Conference on Automation and Computing (ICAC'14), 12-13 September 2014, Cranfield University Bedfordshire MK43 0AL UK. (In Press)

This version is available at <http://eprints.hud.ac.uk/22084/>

The University Repository is a digital collection of the research output of the University, available on Open Access. Copyright and Moral Rights for the items on this site are retained by the individual author and/or other copyright owners. Users may access full items free of charge; copies of full text items generally can be reproduced, displayed or performed and given to third parties in any format or medium for personal research or study, educational or not-for-profit purposes without prior permission or charge, provided:

- The authors, title and full bibliographic details is credited in any copy;
- A hyperlink and/or URL is included for the original metadata page; and
- The content is not changed in any way.

For more information, including our policy and submission procedure, please contact the Repository Team at: E.mailbox@hud.ac.uk.

<http://eprints.hud.ac.uk/>

Modelling and Validation of a Regenerative Shock Absorber System

Ruichen Wang¹, Zhi Chen², Haijun Xu³, Karsten Schmidt⁴, Fengshou Gu¹ and Andrew.D. Ball¹

¹Centre for Efficiency and Performance Engineering, University of Huddersfield, Huddersfield, UK

²Department of Vehicle Engineering, Taiyuan University of Technology, Taiyuan, Shanxi, P.R. China

³School of Mechatronics and Automation, National University of Defense Technology, Changsha, Hunan, P.R. China

⁴Department of Computing and Engineering, Frankfurt University of Applied Sciences, Frankfurt, Germany

Abstract— For effective energy regeneration and vibration dampening, energy regenerative suspension systems have received more studies recently. This paper presents the dynamic modeling and a test system of a regenerative shock absorber system which converts vibration motion into rotary motion through the adjustment of hydraulic flow. Hydraulic circuit configuration achieves the one way flow and energy regeneration during both compression and extension strokes. The dynamic modeling is performed for the evaluation of design concept and the feasibility studies of regenerative shock absorber system theoretically. Based on simulated results, the efficiency of hydraulic transmission is optimized and validated in test system. The results show that the performance of hydraulic fluid, the features of rotary motion and the capability of energy regeneration are verified and compared between dynamic modeling and experiments. Meanwhile, the average power of 118.2W and 201.7W with the total energy conversion of 26.86% and 18.49% can be obtained based on experiments under sinusoidal inputs with 0.07854m/s and 0.1256m/s respectively.

Keywords—hydraulic fluid; energy regeneration; modeling; shock absorber;

I. INTRODUCTION

Vehicles play an important role around the world. Meanwhile, the vehicles' energy harvesting and the improvement of energy efficiency have been more concerned for the last two decades. In 2012, the road transports accounted for 74% (39,468 Ktoe, thousand tons of oil equivalents) of total transport energy consumption in the UK [1]. For commercial vehicles, only 10 to 16% of fuel energy has been used to propel the driving [2]. Most of energy is wasted by the resistances from road conditions, frictions and thermal exhaust. However, the kinetic energy loss by shock absorbers is one of the main energy dissipation in vehicles. Conventional hydraulic shock absorber converted the vibration energy into the dissipation of heat to ensure the ride comfort and road holding.

Many manufactures and researchers are focused on the regenerative suspension system to convert more recoverable energy and decrease energy consumption while assuring the high performance of stabilities and road reliabilities. Since the later 1970s, researchers have analysed the feasibility of regenerative shock absorber theoretically. Karnopp [3] showed that the mechanism and process for the reduction of vehicle energy consumption can be achieved with energy regeneration in conventional

passive shock absorber, especially for electric and hybrid vehicles. The energy consumption in a 4 DOF model has been calculated which approximately 200W by 4 wheels on an irregular road by adjusting the relevant velocity between shock body and wheels [4-5]. In the study of Hsu [6], a General Motors 'impact' model has been performed to estimate the average of recoverable energy for each wheel which equal to 5% (100W) of entire vehicle power in motorway driving with the speed of 35.8mph. Zuo [7] investigated the potential energy regeneration by modelling of the road roughness and vehicle dynamics, and 100-400W from shock absorber at the driving speed of 96km/h can be recovered.

Hydraulic/pneumatic accumulator is utilized as energy storage, or restrains the oscillation of the wheel. Jolly [8] employed the linear motion control in driver seat damper which had a hydraulic device for energy regeneration. The study of Jolly indicated that proper control algorithms can improve the efficiency of energy regeneration. Aoyoma [9] found that the reduction of energy consumption is able to self-power the action of control by the storage of exhaust gas.

The oscillation in shock absorbers can also be converted into electricity which can power other devices or recharge battery by rotary/linear electromagnetic motor. Nakano [10-11] applied two linear DC motors to improve ride comfort by a self-powered active control. In Nakano's studies, one motor worked as generator to power the other as an actuator in order to adjust the performance of vibration. Suda [12] has proposed an electromagnetic damper which is composed of DC motor, planetary gear and a ball screw mechanism. DC motor can rotate in both directions to supply power and recover energy. Bose's active suspension, Michelin active-wheel and University of Texas' active suspension system (ECASS) are designed to improve the performances of suspension system and the capability of energy regeneration by active control strategies [13-15].

Hydraulic transmission can also convert linear motion into rotary motion to produce electricity by generator/electric motor. Levant Power Corporation [16] has built and tested two generation of 'GenShock' prototypes for energy regeneration and adaptive damping control. Z. Fang [17] applied a hydraulic electromagnetic shock absorber (HESA) prototype to study the damping and energy regeneration features.

However, it has found that most these studies are based on experimental works, which is not sufficient for more accurate design to achieve optimized system for both energy regeneration and ride comfort. Therefore, these forces on developing a model based on energy regenerative shock absorber system which converts linear motion into rotary motion by modelling and testing. The dynamic analysis of hydraulic performances and the capability of energy regeneration are optimized and validated.

II. DESIGN CONCEPT

As shown in Fig.1, a prototype regenerative energy shock absorber can be designed to consist of a hydraulic cylinder, four check valves, a hydraulic accumulator, a hydraulic motor, a generator, pipelines and an oil tank. In addition, the hydraulic motor is coupled with a DC permanent magnetic generator for converting the hydraulic flow energy into electricity.

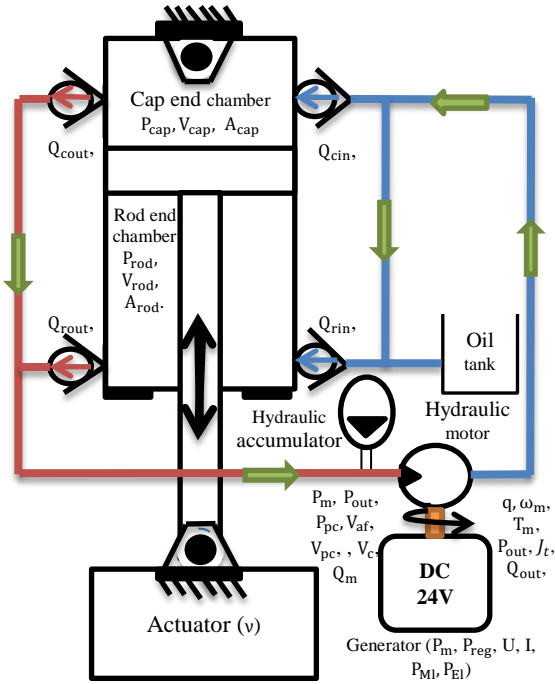

Figure 1. The schematic of regenerative shock absorber

The cylinder is added two ports by a double acting hydraulic cylinder. As the piston of the hydraulic cylinder moves reciprocally due to excitations of oscillating road profiles, the fluid in the cylinder will be forced to flow into the fluid chamber of the connecting hoses in front of the motor. Driven by the pressurized flow, the hydraulic motor will produce rotary motion which will drive the DC generator to produce electricity.

In order to realize the continue flow for driving the hydraulic motor continuously, the flow direction is controlled by the four check valves and the pressure oscillation is adjusted by the hydraulic accumulator.

To study the performance of energy regenerative shock absorber system, the road excitation is created by an actuator which can be controlled to produce different

types of excitations for studying the performance and dynamics of different components.

III. MATHEMATICAL MODEL AND ANALYSIS

To obtain accurate understandings of the dynamic behaviour of the system and determine parameters of each component, a dynamic model needs to be developed for analysing the effects of different components on the performance of energy regeneration. In addition, the dynamic modelling will be critical for controlling damping forces to achieve the ride comfort.

A. Piston Motion

For the easy understanding of the system, the input which is generated by the actuator is assumed to vary in a sinusoidal way according to the form of

$$v = 2\pi f S \sin(2\pi ft) \quad (1)$$

where f is the frequency and S is the amplitude. Based on (1), the rate of changing position of the piston \dot{S}_a at any time can be calculated by

$$\dot{S}_a = v \quad (2)$$

The volumes of the cap end V_{cap} and rod end chamber V_{rod} can be calculated by (3) and (4) respectively:

$$V_{cap} = A_{cap}(S_0 - S_a) = \frac{\pi \cdot D_{bore}^2}{4}(S_0 - S_a) \quad (3)$$

$$V_{rod} = A_{rod}(S_0 - S_a) = \frac{\pi \cdot (D_{bore}^2 - D_{rod}^2)}{4}(S_0 - S_a) \quad (4)$$

where, S_0 is the starting position of the piston referring to its lowest position.

Due to the motion of the piston the hydraulic oil will be forced to flow out from the cylinder chambers. For the flow going out through the check valves from the two cylinder chambers Q_{cout} and Q_{rout} can be calculated based on the Bernoulli's principle according to

$$\begin{cases} Q_{cout} = C_d \cdot A_{cv} \cdot \text{sgn}(P_{cap} - P_m) \cdot \sqrt{\frac{2}{\rho} \cdot |P_{cap} - P_m|} \\ \quad \text{for } P_{cap} > P_m \\ Q_{rout} = C_d \cdot A_{cv} \cdot \text{sgn}(P_{rod} - P_m) \cdot \sqrt{\frac{2}{\rho} \cdot |P_{rod} - P_m|} \\ \quad \text{for } P_{rod} > P_m \end{cases} \quad (5)$$

In the same way the oil flow entering into the two chambers Q_{cin} and Q_{rin} can be calculated by

$$\begin{cases} Q_{cin} = C_d \cdot A_{cv} \cdot \text{sgn}(P_m - P_{cap}) \cdot \sqrt{\frac{2}{\rho} \cdot |P_m - P_{cap}|} \\ \quad \text{for } P_m > P_{cap} \\ Q_{rin} = C_d \cdot A_{cv} \cdot \text{sgn}(P_m - P_{rod}) \cdot \sqrt{\frac{2}{\rho} \cdot |P_m - P_{rod}|} \\ \quad \text{for } P_m > P_{rod} \end{cases} \quad (6)$$

Where C_d is the discharge coefficient; A_{cv} is the area of check valve port; P_{cap} , P_{rod} and P_m represent the pressures in the cap end chamber, the rod end chamber and the motor inlet chamber respectively; and ρ is the density of the oil.

The check valve is ready to open if the pressure out from hydraulic cylinder is higher than that in the other end, plus the cranking pressure is provided by the spring force. Hydraulic oil flows through the orifice and propel the laminar resistance if it is open. If check valve is closed, the leakage of flow is considered to pass the laminar resistance. The discharge coefficient which depends on geometry and distribution of orifice is used to calculate turbulent flow through orifices of check valve. The reduction of orifice area by cranking pressure and leakage area are neglected in modelling instead by a constant value.

With the flows and piston motions, the pressures in the two cylinder chambers can be calculated by

$$P_{cy} = \begin{cases} P_{cap} = \frac{\beta}{V_{cap}}(A_{cap} \cdot v - Q_{cout} + Q_{cin}) \\ P_{rod} = \frac{\beta}{V_{rod}}(A_{rod} \cdot (-v) - Q_{rout} + Q_{rin}) \end{cases} \quad (7)$$

where the bulk modulus of hydraulic oil is β and can be obtained by Hoffmann's model[18]:

$$\beta = \beta_{Pmax}[1 - \exp(-0.4 - 2 \times 10^{-7}P)] \quad (8)$$

to reflect the dependency of hydraulic fluids compressibility on pressure amplitude, volume and entrained air. β_{Pmax} is reference bulk modulus. The entrained air induces inevitable air bubbles during the operation in test system which is effect on the efficiency of hydraulic flow.

B. Hydraulic Accumulator and Motor

It can be found from above equations that the flow rate and pressure will highly oscillate because of the time-varying motion of the piston. To smooth the flow, a gas-charged accumulator with fast dynamic responses is usually connected into the hydraulic system.

Generally, there are two chambers in a gas-charged accumulator, gas chamber and fluid chamber. Initially, gas chamber is charged in pre-charge pressure P_{pc} so that obtain the initial volume V_{pc} .as well. Normally, pressure in gas chamber is equal to that in fluid chamber. The effect of gas-charged accumulator is reflected by the changing volume in fluid chamber V_{af} . Therefore, the equations can be written as:

$$V_{pc} = k_s \cdot P_{pc} \quad (9)$$

$$V_{af} = \begin{cases} V_{pc} \left(\frac{P_{pc}}{P_m}\right)^{\frac{1}{k}} + V_c \left(1 - \frac{P_{pc}}{P_{cy}}\right)^{\frac{1}{k}} \\ k_s \cdot P_{cy}, \quad \text{for } P_{cy} \leq P_{pc} \end{cases} \quad (10)$$

where, k_s and V_c are the structural compliance of the accumulator inlet port structure and the accumulator capacity.

As the hydraulic accumulator is mounted before inlet of hydraulic motor, the total volume V_t before motor is the hydraulic accumulator fluid chamber V_{af} and the volume including that of pipeline and the hydraulic motor chamber V_{lm} . In addition, the pressure loss in moving fluid at different velocity across though the pipeline is needed to be considered based on Darcy-Weisbach equation [19]. Therefore, the pressure P_{in} and flow Q_{in} at the inlet of the hydraulic motor inlet are shown as follows (11)-(13):

$$P_m = \frac{\beta}{V_t} \cdot (Q_{cout} + Q_{rout} - Q_m) \quad (11)$$

$$V_t = V_{lm} + V_{af} \quad (12)$$

$$Q_m = \frac{D_m \cdot \omega_m}{2 \cdot \pi} \cdot \eta_v \quad (13)$$

$$P_{loss} = \frac{32\mu L \rho (Q_{cout} + Q_{rout})}{D_{pipe}^2 A_{pipe}} \quad (14)$$

where D_m is the displacement of hydraulic motor, ω_m is the shaft speed of hydraulic motor and generator, η_v is the volumetric efficiency of hydraulic motor, D_{pipe} is the diameter of pipeline, μ is the dynamic viscosity of shock oil, L is the length of pipeline.

With the action of the pressure in (11), the hydraulic motor will generate a driving torque T_m , which tends to produce shaft rotation and can be estimated by:

$$T_m = \frac{D_m(P_m - P_{loss} - P_{out})}{2 \cdot \pi} \quad (15)$$

where P_{out} is the pressure of hydraulic motor outlet or the tank pressure.

C. Torque and Power

The hydraulic motor is coupled to the DC generator by a shaft coupling. Assuming that the rotational friction torque T_{rf} for the the DC generator and the motor is T_{rf} , the moment of shaft inertia is J_m and load for generating electricity is T_l need, the rotational motion of the two motor will be

$$J_t \dot{\omega}_m = T_m - T_{rf} - T_l \quad (16)$$

The calculations of moment of inertia for modelling and test are shown in (17). In test system, the mass of rotational components includes shaft, armature of generator and orbiting gear. Therefore, the total moment of inertia in modelling is given by:

$$J_t = \frac{1}{2} \cdot m_h \cdot r_h^2 + \frac{1}{2} \cdot m_g \cdot r_g^2 + \frac{1}{2} \cdot m_a \cdot r_a^2 \quad (17)$$

where, m_h and m_g are the mass of rotational shafts in hydraulic motor and DC generator. r_h and r_g are radius of shafts. m_a is the mass of generator armature, r_a is the distance of axis rotation of armature.

The rotational friction torque [20] can be expressed by:

$$T_{rf} = \begin{cases} \frac{\omega_{th} C_{tv} + ((T_{bk} - T_c) \cdot e^{-\omega_{th} C_v + T_c}) \cdot \omega_m}{\omega_{th}}, & \text{for } |\omega_m| < \omega_{th} \\ \omega_m C_{tv} + ((T_{bk} - T_c) \cdot e^{-\omega_m C_v + T_c}) \cdot \text{sgn}(\omega_m), & \text{for } |\omega_m| \geq \omega_{th} \end{cases} \quad (18)$$

where, T_{bk} and T_c are breakaway friction torque and coulomb friction torque. C_{tv} and C_v are viscous friction coefficient and the coefficient of the transition between the static and the coulomb frictions. ω_{th} is the velocity of threshold. In modelling analysis, external load T_l is instead by a constant normally.

Rather than a constant load, the torque due to generator is modelled as

$$T_l = c \cdot \omega_m + T_{con} \quad (19)$$

to include the effects of the high speed fluctuation and the basic operation process of the DC generator under constant resistive load. The load coefficient c can be adjusted based on the electrical power output and motor average speed.

The effective mechanical power input P_{input} can be calculated by:

$$P_{input} = P_{cap} \cdot A_{cap} \cdot v + P_{rod} \cdot A_{rod} \cdot v \quad (20)$$

During the experiment, the potential electrical power is obtained by measuring the voltage and current at the two terminals of a load resistor, which can be calculated by:

$$P_{reg} = U \cdot I \quad (21)$$

The power output by generator is always less than the mechanical power input from motor because of different losses such as the mechanical and electrical losses.

TABLE I. ADDITIONAL PARAMETERS IN MODELLING OF REGENERATIVE SHOCK ABSORBER SYSTEM

Symbo l	Parameters		Symbo l	Parameters	
	Value	Unit		Value	Unit
V_{cap}	$2 \cdot 10^{-4}$	m^3	V_{lm}	$0.16 \cdot 10^{-3}$	m^3
V_{rod}	$1.3 \cdot 10^{-4}$	m^3	η_v	63.5%	@0.07854m/s @0.01256m/s
A_{cap}	$2 \cdot 10^{-3}$	m^2	J_t	0.003	kg/m^3
A_{rod}	$1.3 \cdot 10^{-3}$	m^2	T_{bk}	1	Nm
S_0	100	mm	T_c	0.01	Nm
C_d	0.6		C_{tv}	0.005	Nm/(rad/s)
A_{cv}	$3 \cdot 10^{-5}$	m^2	C_v	1	rad/s
β_{Pmax}	$1.8 \cdot 10^9$	Pa	ω_{th}	2	rad/s
k_s	$5.2 \cdot 10^{-13}$		c	0.0525	Nm/(rad/s)
k	1.4		T_{con}	0.2	Nm
L	0.75	m	μ	22	cSt

The components data has used in both test system and dynamic model. The key parameters for the dynamic analysis are shown in Table I. In addition, not only hydraulic motor efficiency, but also total torque and bulk modulus are varied with pressures which can be found in (8) and (11).

IV. EXPERIMENTAL VERIFICATION

A. Test System

According to the design concept in Fig.1 and preliminary calculation based on the models in section III, a test system was developed to evaluate the performance of energy regeneration based on the dimension of a typical shock absorber commonly used a commercial car. Fig. 2 illustrates the test system of the shock absorber. The specification of key components including a double acting cylinder, a diaphragm accumulator, four check valves, an orbiting gear hydraulic motor and a permanent magnetic DC generator is provided in Table II.

To simulate road excitations, a 4-poster ride simulator was used to test the system under given motions. As shown in Fig.2, one end of the double acting cylinder is fixed to one of the 4 actuators available in the simulator and the other end is fixed on a heavy frame so that the piston inside the double acting cylinder can be driven by the actuator to follow the corresponding oscillation motions which are realised by controlling the hydraulic systems of the simulator.

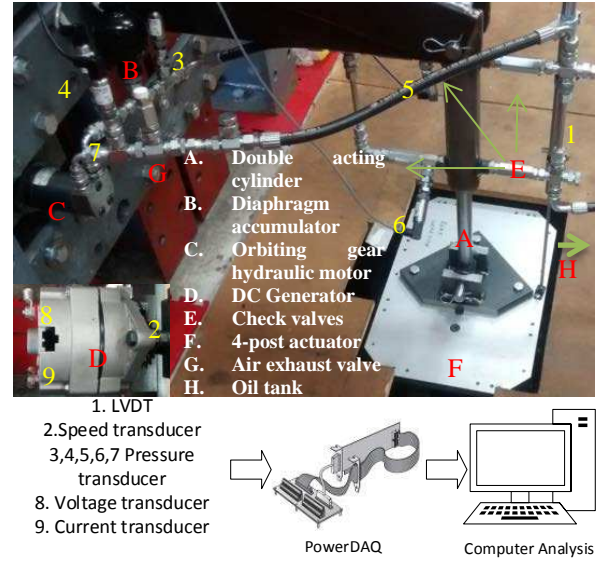

Figure 2. The main components of regenerative shock absorber system

To examine the pressure variations and estimate the flows in the system, five pressure transducers are installed, as shown in Fig. 2, to measure the pressure in the cap end chamber, the rod end chamber, line pressures before and after the motor respectively. An LVDT transducer is used to measure the piston displacement. A shaft encoder is used to measure the motor speed. In addition a voltage sensor and a current sensor are used to measure the electrical output consumed by a power resistor of 10Ω . All of these sensor outputs are fed to a multiple channel data acquisition system which collects the data at 10 kHz and 12bit resolution for a comparison with the model results.

Both modelling and experimental analysis are under the condition of sinusoidal inputs with different amplitudes and frequencies, which allow the analysis to be carried out with high accuracy and gain a general understanding the dynamic behaviour of the system. Specifically, two typical inputs: 0.07854m/s at 0.5Hz, (25mm stroke) and 0.1256m/s at 1Hz (20mm stroke) are

examined in this study for validating the model at low and high inputs respectively.

TABLE II. MAIN PARAMETERS OF REGENERATIVE SHOCK ABSORBER SYSTEM

Components	Specification		
	Components in test system		
Cylinder	$S_{max}=200\text{mm}$	$D_{bore}=50\text{mm}$	$D_{rod}=30\text{mm}$
Accumulator	$P_{pc}=20\text{bar}$	$V_{pc}=0.16\text{L}$	1/2'
Motor	$D_m=8.2\text{cc}$	Nominal speed=2450rpm	$D_h=16\text{mm}$
Generator	DC output, includes built in rectifier	2.33 phase magnetic field	$D_g=17\text{mm}$
Check valve	3/8' BSPP	Max pressure=350bar	$P_{cr}=\pm 0.4/0.7$ (cranking pressure)
Hose	$D_{pipe}=3/8'$	Max pressure=800bar	
4-poster actuator	Max. velocity=1.9m/s	Static load. =550kg	Preload. =60kg

B. Validating Results and Discussion

In test system, a few amount of air contains in cylinder chambers and hydraulic circuit. In form of air bubbles in test system leads to the reduction of oil reliability and effective bulk modulus. And, air bubble is possible to produce unexpected noise and shock, and reduce the service life of cylinder. According to (6)-(8), the air exhaust valve is employed to minimize the air cavity and air bubble in hydraulic system. Oil tank is also used to compensate oil timely in return flow. In addition, based on (11) and (14), low dynamic viscosity of shock oil is employed and the length of hose is reduced to prevent pressure loss when oil flows through it.

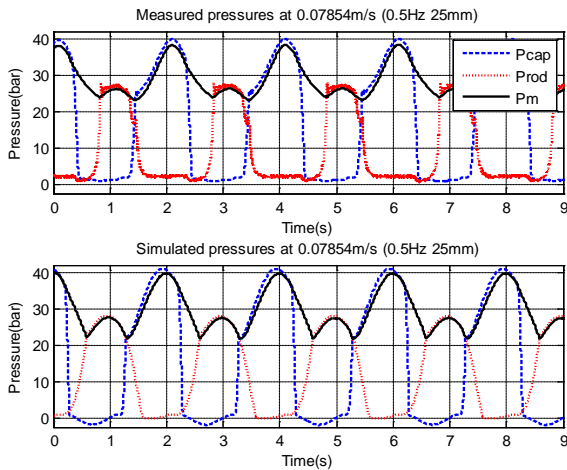

Figure 3. Measured and simulated pressures at 0.5Hz 25mm

In Fig. 3 and Fig 4, the pressures of cap end chamber, rod end chamber and hydraulic motor inlet are simulated and measured. Equation (9) and (10) indicate that the volume variation of hydraulic accumulator regularizes the hydraulic flow to improve the efficiency of hydraulic motor in low-speed or high-pressure. Moreover, a few of pressure is consumed to propel the cranking pressure by compressing the spring in check valve. In test system, the length of check valve spring is cut 1/3 to decrease pressure loss and increase dynamic response of oil flow. The

orifices in check valve are also enlarged to reduce the effect of flow discharge due to (5) and (6).

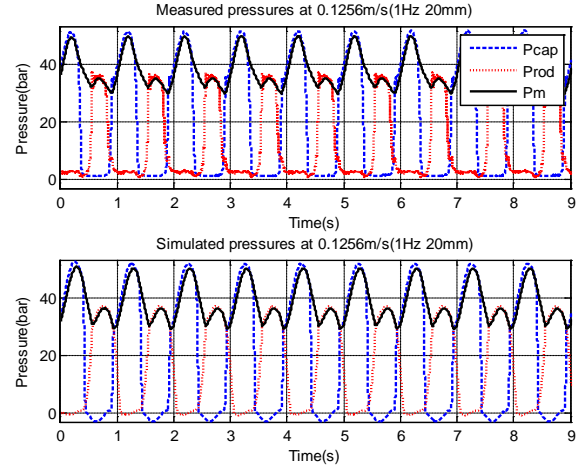

Figure 4. Measured and simulated pressures at 1Hz 20mm

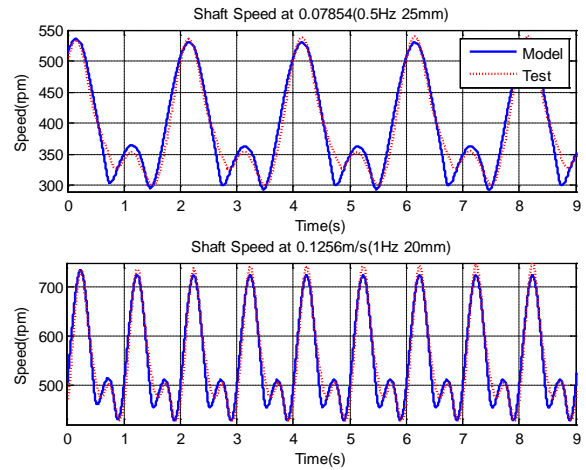

Figure 5. Measured and simulated shaft speeds

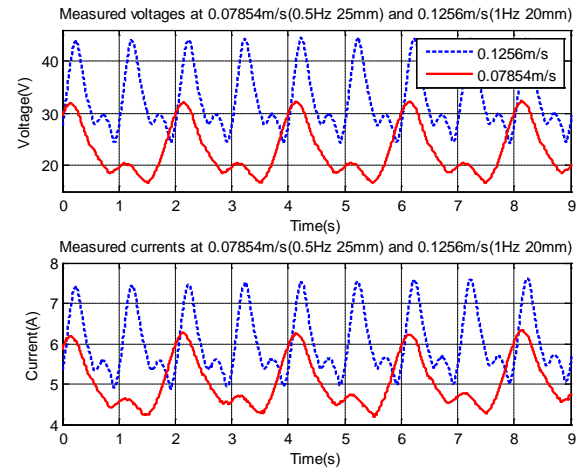

Figure 6. Measured voltages and currents

In Fig. 5, the average shaft speeds for modelling and test at 0.1256m/s are 548.1rpm and 510.9rpm approximately, which are 393.4 rpm and 364.8 rpm at 0.07854m/s. The shaft speed depends on total torque and the moment of inertia. A heavy generator is utilized in testing. The large moment of inertia can act as rotational

kinetic energy storage to improve the stability of rotary motion. The stable shaft speed assists the energy regeneration by DC generator.

In Fig. 6, the voltage and current are measured by voltage and current transducers in test system. The average voltage and current are 22.8V, 32.7V and 5.05A, 6.03A at 0.5Hz and 1Hz. The voltage output depends upon generator armature speed, field current I. The higher armature speed and field current, the stronger electromotive force is induced to produce the effective electricity.

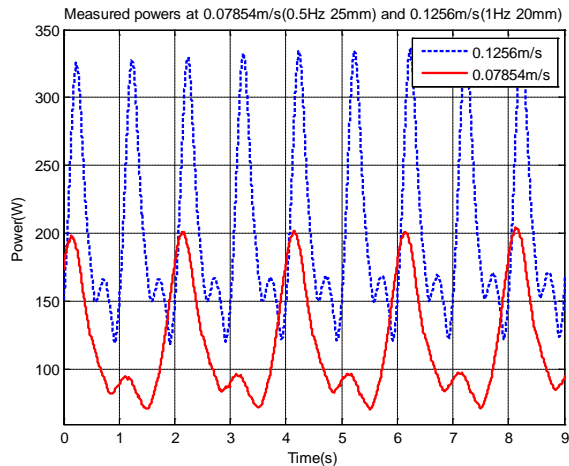

Figure 7. The capability of energy regeneration

In Fig. 7, the capability of energy regeneration is shown for 0.07854m/s and 0.1256m/s which the average power outputs are 118.2W and 201.7W. The average mechanical power inputs are 440W and 1091W, so the system energy conversion efficiency is 26.86% and 18.49%.

V. CONCLUSION

A regenerative shock absorber system is set up and tested, which utilizes hydraulic and mechanical transmissions so that it can convert the linear motion into rotary motion to generate electricity by excitation input. A dynamic modelling of regenerative energy shock absorber system has been analysed to guide the test system theoretically. The dynamic modelling and test system of energy regenerative shock absorber are evaluated and optimized with sinusoidal input. Hydraulic circuit used check valve to derive one-way flow. The results indicate that hydraulic circuit configuration regularizes the hydraulic flow to improve the efficiency of hydraulic motor in low-speed or high-pressure. In parallel, DC generator is provided much more stable shaft speed for high efficiency of energy regeneration. Meanwhile, the capability of energy regeneration in experiments at 0.07854m/s and 0.1256m/s obtains the average power 118.2W and 201.7W, while the total energy conversion are 26.86% and 18.49%.

REFERENCES

[1] Energy consumption in the UK. [Online]. Available: <https://www.gov.uk/government/collections/energy-consumption-in-the-uk>

[2] Electric Vehicle Battery Systems. p. 252, S. Dhameja, Newnes, 2001.

[3] D. Karnopp, "Power Requirements for Vehicle Suspension Systems," *Vehicle System Dynamics: International Journal of Vehicle Mechanics and Mobility*, vol. 21, no. 1, pp. 65–71, 1992.

[4] S. A. Velinsky and R. A. White, "Vehicle Energy Dissipation Due to Road Roughness," *Vehicle System Dynamics: International Journal of Vehicle Mechanics and Mobility*, vol. 9, no. 6, pp. 359–384, 1980.

[5] L. Segel and X. Lu, "Vehicular resistance to motion as influenced by road roughness and highway alignment," *Australian Road Research Board ARRB*, vol. 12, no. 4, pp. 211–222, 1982.

[6] P. Hsu, "Power recovery property of electrical active suspension systems," In *Energy Conversion Engineering Conference, Proceedings of the 31st Intersociety*, 1996, vol. 3, pp. 1899–1904 vol.3.

[7] L. Zuo and P. Zhang, "Energy harvesting, ride comfort, and road handling of regenerative vehicle suspensions," in *Proc. DSCC*, 2012, pp. 295–302.

[8] M. R. Jolly and D. L. Margolis, "Regenerative Systems for Vibration Control," *Journal of Vibration and Acoustics*, vol. 119, no. 2, pp. 208–215, Apr. 1997.

[9] Y. Aoyama, K. Kawabata, S. Hasegawa, Y. Kobari, M. Sato, and E. Tsuruta, "Development of the Full Active Suspension by Nissan," SAE International, Warrendale, PA, SAE Technical Paper 901747, Sep. 1990.

[10] K. Nakano, S. Nakadai and Y. Suda, "Study On the Self-Powered Active Vibration Control," 1999.

[11] K. Nakano, S. Nakadai and Y. Suda, "Self-Powered Active Vibration Control with Continuous Control Input," *JSME International Journal Series C*, vol. 43, no. 3, pp. 726–731, 2000.

[12] Y. Suda, "Study on electromagnetic damper for automobiles with nonlinear damping force characteristics: road test and theoretical analysis," *Dynamics of vehicles on roads and on tracks: proceedings of the 18th IAVSD Symposium held in Kanagawa, Japan*, pp. 637–646, Aug. 2003.

[13] W. D. Jones, "Easy ride: Bose Corp. uses speaker technology to give cars adaptive suspension," *IEEE Spectrum*, vol. 42, no. 5, pp. 12–14, May. 2005.

[14] Michelin re-invents the wheel, [Online]. Available: <http://www.sae.org/mags/aei/4604>

[15] J. H. Beno, D. A. Weeks, D. A. Bresie, A. M. Guenin, J. S. Wisecup, and W. Bylsma, "Experimental Comparison of Losses for Conventional Passive and Energy Efficient Active Suspension Systems," SAE International, Warrendale, PA, SAE Technical Paper 2002-01-0282, Mar. 2002.

[16] J. Mossberg, Z. Anderson, C. Tucker, and J. Schneider, "Recovering Energy from Shock Absorber Motion on Heavy Duty Commercial Vehicles," SAE International, Warrendale, PA, SAE Technical Paper 2012-01-0814, Apr. 2012.

[17] Z. Fang, X. Guo, L. Xu and H. Zhang, "Experimental Study of Damping and Energy Regeneration Characteristics of a Hydraulic Electromagnetic Shock Absorber," *Advances in Mechanical Engineering*, May. 2013.

[18] W. Hoffmann, "Dynamic behavior of hydraulic systems, automatic model building and digital simulation". Ph.D. thesis RWTH Aachen, 1981.

[19] B. Gleen, Oklahoma State University, Darcy-Weisbach Equation, [Online]. Available: <http://biosystems.okstate.edu/darcy/DarcyWeisbach/Darcy-WeisbachEq.htm>

[20] B. Armstrong, C.C. de Wit, "Friction Modeling and Compensation", *The Control Handbook*, CRC Press, 1995.