

# **DEVELOPMENT OF HYDROENTANGLED NONWOVEN STRUCTURES FOR FASHION GARMENTS**

**BY**

**MUHAMMAD SHAHBAZ CHEEMA**

**B.T.T.M. (H) (Textile Technology); M.Sc. (Advanced Textiles)**

**A thesis submitted in partial fulfilment of the requirements of the  
University of Bolton for the degree of Doctor of Philosophy**

**December 2016**

**Institute of Materials Research and Innovation (IMRI)**



## **DECLARATION**

This work has not been previously accepted in substance for any degree and is not concurrently submitted in candidature of any other higher degree.

# *Dedication*

**In the name of God, the Most Gracious, the Most Merciful**

I would like to dedicate my thesis to my beloved family.

## ACKNOWLEDGEMENTS

During the completion of the project objectives, many people assisted me and offered their support. I would like to express my sincere appreciation to my supervisor, and Director of Study, Professor Tahir H. Shah, who helped me with moral support, his time and expertise in technical textiles and polymeric materials. He guided me in right directions in spite of his busy schedules.

I would also extend my appreciation to my second supervisor Professor Subhash Anand, my second supervisor, who helped me with his expertise and useful discussions, which contributed to the solution of some of my problems throughout the project.

This list would be incomplete, if I do not thank lab support staff, particularly Akbar Zarei for his consistent help with the experimental work and for making the research environment cheerful. I would also like to thank all my friends who have helped me directly or indirectly to complete this project with a sense of satisfaction.

I would also like to express my gratitude to Professor Stephen Russell and his team at University of Leeds for their support and for allowing the use of the fabric making and testing facilities in their laboratory.

I have no words to express the gratitude for the love and support of my parents, brothers and sisters. I express my sincere thanks to my wife, Asma, for her moral support and for standing by me during the difficult times. This achievement is a small return for her constant support and encouragement.



## **ABSTRACT**

Making fabrics for apparel applications through conventional methods such as woven and knitting processes are lengthy and expensive because these processes start from ginning, spinning, weaving and knitting process. For saving the cost and quick response to the apparel market, many researchers and companies are trying to explore the non-conventional methods to produce fabrics for apparel applications by skipping some processing steps during apparel fabrics manufacturing process.

For decades, nonwovens are being used as supporting materials in the clothing industry, as such, they are used as fusible interlinings and reinforcements. Since last few years, because of the advancements in the nonwoven technology and materials, innovative nonwoven fabrics have been developed with the acceptable aesthetical properties for fashion garments. The most prominent example of the nonwoven fabric for clothing is “Evolon” produced by Freudenberg Germany.

The main aim of this study was to investigate the limitations in the current nonwoven fabrics used for the apparel applications and to realise the functional properties of the fabrics that are suitable for apparel applications.

Fabrics for apparel applications, especially for garments, require aesthetical and mechanical properties such as drape, hand feel, flexural rigidity, moisture management, tensile characteristics, thermal characteristics and air permeability. This study aims to develop nonwoven fabrics with enhanced mechanical and aesthetical characteristics by selecting the appropriate materials and nonwoven processes and process parameters.

The developed hydroentangled nonwoven fabric was comprised on Tencel® and bicomponent (PE/PET) sheath core staple fibres.

In this study, two different processes were employed for the preparation of the nonwoven fabrics for apparel applications. The first process consisted of carding, needlepunching and hydroentanglement. The second process involves carding, pre-needling (for tucking of fibres) and hydroentanglement.

The prepared fabrics were characterised according to the British Standards (BS 3356:1990, BS 9237:1995, BS 13934-1:1999) and the results were compared with a standard plain-weave cotton woven fabric and also with commercially available nonwoven fabric (Evolon®).

The developed hydroentangled nonwoven fabric produced at hydroentanglement energy of 4.44 kJ/kg, showed better drape properties owing to its flexural rigidity of 252 mg cm in MD while the corresponding commercial hydroentangled fabric displayed a value of 1340 mg cm in MD. Tensile strength of the developed hydroentangled fabric showed an approximately 200% increase than that of the commercial hydroentangled fabric. Similarly, the developed hydroentangled fabric showed higher properties in term of air permeability such as developed hydroentangled fabric exhibited 448 mm/sec and Evolon fabric exhibited 69 mm/sec at 100 Pa pressure. Absorbency properties of developed hydroentangled fabric (S14) showed almost 500% higher than the Evolon and 200% higher than the woven fabric, mainly because of the fibre morphology and fabric structure. Developed fabric (S14) showed a maximum “% loss in warmth to touch” that is 541% loss as compared with Evolon 365% and woven 226%. Thus for apparel fabrics, the work combining existing methods of nonwoven production, provides additional benefits in terms of cost, time and also helps in reducing the carbon footprint for the apparel fabric manufacture.

## Table of Contents

Declaration .....	ii
Dedication .....	iii
Acknowledgement .....	iv
Abstract .....	v
List of Figures .....	xvi
List of Tables .....	xxiii
Acronyms and Abbreviations .....	xxv
<b>Chapter 1.....</b>	<b>1</b>
<b>Introduction to Nonwoven Apparel.....</b>	<b>1</b>
1.1 Introduction .....	1
1.2 Purpose of this study .....	4
1.3 Significance of this study .....	5
1.4 Scope of this study .....	5
1.5 Thesis structure .....	6
1.6 Summary.....	8
<b>Chapter 2 .....</b>	<b>10</b>
<b>Literature Review.....</b>	<b>10</b>
2.0 Introduction .....	10
2.1 Historical background: Nonwovens in apparel applications .....	10
2.2 Performance characteristics of fabrics for clothing .....	23
2.2.1 Aesthetic properties .....	23
2.2.2 Mechanical properties .....	25
2.3 Materials selection .....	26

2.3.1 Flexural rigidity .....	27
2.3.1.1 Fibre fineness .....	28
2.3.1.2 Fibre length .....	28
2.3.1.3 Fibre crimp .....	28
2.3.2 Tensile properties .....	29
2.3.2.1 Fibres .....	31
2.3.2.2 Fabric structure .....	32
2.3.3 Air permeability .....	35
2.3.4 Thermophysiological properties .....	36
2.4 Web formation .....	37
2.4.1 Wet-laid web .....	38
2.4.2 Dry-laid web .....	39
2.4.3 Air-laid web.....	40
2.4.4 Spun-laid web .....	41
2.5. Pre-needling process .....	41
2.6 Hydroentanglement process .....	43
2.6.1 Introduction .....	43
2.6.2 Background of hydroentanglement Process .....	47
2.6.3 Parameters affecting properties of hydroentangled fabrics .....	48
2.6.4 Supporting media .....	51
2.6.5 Injector action .....	52
2.6.6 Dryer .....	52
2.7 Selection of processes for developing nonwoven clothing for apparel applications.....	52
2.7.1 Nonwoven manufacturing methods.....	53

2.8 Summary.....	53
<b>CHAPTER 3 .....</b>	<b>55</b>
<b>Materials and Experimental Methods .....</b>	<b>55</b>
3.1 Raw materials .....	55
3.1.1 Introduction .....	55
3.1.2 Tencel® .....	55
3.1.2.1 Moisture management .....	56
3.1.2.2 Softness .....	57
3.1.2.3 Tensile characteristics .....	58
3.1.3 Bi-component sheath/core (PE/PET) fibre .....	58
3.2 Processing methods .....	60
3.2.1 Web preparation .....	60
3.2.2 Needlepunching and pre-needling .....	60
3.2.2.1 Precautions during needling process .....	62
3.2.2.2 Drawbacks of pre-needling .....	63
3.2.3 Hydroentanglement process .....	63
3.2.3.1 Calculations of specific energy .....	66
3.2.4 Experimental procedure .....	67
3.2.5 Calendaring process .....	69
3.2.6 Thermal bonding .....	71
3.2.7 Reference samples .....	74
3.2.7.1 Evolon® .....	74
3.2.7.2 Woven .....	75
3.3 Test methods.....	75

3.3.1 Introduction .....	75
3.3.2 Flexural rigidity .....	75
3.3.2.1 Test procedure .....	76
3.3.3 Tensile testing .....	77
3.3.3.1 Test procedure .....	78
3.3.4 Air Permeability .....	78
3.3.4.1 Test procedure .....	79
3.3.4.2 Problem in assessing the result .....	79
3.3.5 Moisture management .....	80
3.3.5.1 Wicking .....	80
3.3.5.1.1 Test procedure .....	81
3.3.5.2 Absorption .....	82
3.3.5.2.1 Test procedure .....	82
3.3.6 Tearing test .....	83
3.3.6.1 Test procedure .....	83
3.3.7 Thermophysiological test .....	84
3.3.7.1 Test procedure .....	84
3.3.7.1.1 Thermal resistance .....	85
3.3.7.1.2 Water vapour resistance .....	85
3.4 Summary .....	86
<b>CHAPTER 4 .....</b>	<b>88</b>
<b>Results and Discussion .....</b>	<b>88</b>
4.1 Preliminary study .....	89
4.1.1 Flexural rigidity .....	90

4.1.1.1 Flexural rigidity of thermally bonded samples .....	94
4.1.2 Tensile properties .....	102
4.1.2.1 Tensile strength after thermal bonding process .....	106
4.2. Detailed study .....	108
4.2.1 Dimensional properties .....	109
4.2.1.1 Thickness .....	109
4.2.1.2 Fabric area density .....	113
4.2.1.3 Bulk density.....	114
4.2.2 Bending rigidity.....	115
4.2.2.1 Bending rigidity of samples prepared by the hybrid process (needle punching and hydroentanglement process) .....	118
4.2.2.2 Bending rigidity of samples prepared through pre-needling and hydroentanglement process .....	120
4.2.2.3 Bending rigidity of the commercial nonwoven and woven fabric .....	121
4.2.2.4 Effect of thickness on the bending rigidity of the fabrics.....	122
4.2.2.5 Effect of area density on the bending length of the fabrics .....	124
4.2.3 Effect of hydro pressures on flexural rigidity of nonwoven fabrics (Hybrid process).....	128
4.2.3.1 Fabric produced at 50 bars hydro pressure .....	128
4.2.3.2 Fabric Produced at 75 Bar Hydro Pressure .....	130
4.2.3.3 Fabric Produced at 100 Bars Hydro Pressure .....	131
4.2.3.4 Fabric Produced at 125 Bars Hydro Pressure .....	134
4.2.4 Moisture management .....	135
4.2.5 Hydroentangled nonwoven fabric .....	140
4.2.5.1 Hydroentangled and thermal bonded fabrics .....	141

4.2.5.2 Hydroentangled and calendared bonded fabric .....	142
4.2.6 Woven and Evolon samples .....	142
4.2.7 Hydroentangled fabric (pre-needling) .....	143
4.2.7.1 Hydroentangled and thermal bonded fabric (pre-needling) .....	145
4.2.7.2 Hydroentangled and calendared fabrics (Pre-needling) .....	145
4.2.8 Absorption .....	145
4.2.8.1 Effect of fabric density on absorption of fabric .....	151
4.2.8.2 Effect of fabric thickness on absorption of the fabric .....	154
4.2.9 Tensile properties of hydroentangled nonwoven fabrics produced through needlepunching process .....	157
4.2.9.1 Effect of hydro pressure on the tensile strength of hydroentangled fabrics.....	158
4.2.9.2 Effect of hydro pressures on the extensibility of the hydroentangled fabric.....	161
4.2.9.3 Hydroentangled fabric produced at 50 bars (Hybrid Sample).....	164
4.2.9.3.1 Effect of thermal finishing process on hydroentangled nonwoven fabric produced at 50 bars pressure .....	166
4.2.9.3.2 Effect of calendaring process on hydroentangled nonwoven fabric produced at 50 bars pressure .....	166
4.2.9.4 Tensile properties of hydroentangled fabric produced at 75 bars pressure.....	168
4.2.9.4.1 Effect of thermal bonding on the tensile properties of hydroentangled nonwoven fabric S6 produced at 75 bars .....	170
4.2.9.4.2 Effect of calendaring process on hydroentangled nonwoven fabric S10 produced at 75 bars pressure .....	171
4.2.9.5 Hydroentangled fabric produced at 100 bar pressure .....	173



4.2.9.5.1 Effect of thermal bonding on the tensile properties of hydroentangled nonwoven fabric S7 produced at 100 bars .....	175
4.2.9.5.2 Effect of calendaring process on the tensile properties of hydroentangled nonwoven fabric produced at 100 bars .....	176
4.2.9.6 Tensile properties of hydroentangled fabric produced at 125 bars pressure.....	179
4.2.9.6.1 Effect of thermal bonding on the tensile properties of the hydroentangled nonwoven fabric S8 produced at 125 bars .....	180
4.2.9.6.2 Effect of calendaring process on the tensile properties of the hydroentangled nonwoven fabric S12 produced at 125 bars .....	181
4.2.10 Tensile properties of hydroentangled nonwoven fabrics (pre-needlepunching process).....	183
4.2.10.1 Hydroentangled fabric produced at 100 bars hydro pressure.....	183
4.2.10.1.1 Effect of thermal bonding on the tensile properties of the hydroentangled nonwoven fabric S15 produced at 100 bars hydro pressure (Pre-needling) .....	186
4.2.10.1.2 Effect of calendaring process on the tensile properties of hydroentangled nonwoven fabric S17 (pre-needling) produced at 100 bars hydro pressure .....	188
4.2.10.2 Hydroentangled fabric produced at 125 bars hydro pressure.....	189
4.2.10.2.1 Effect of thermal bonding on the tensile properties of hydroentangled nonwoven fabric S16 (pre-needling) produced at 125 bars hydro pressure .....	191
4.2.10.2.2 Effect of calendaring process on the tensile properties of hydroentangled nonwoven fabric S18 (pre-needling) produced at 125 bars hydro pressure .....	192
4.2.11 Tensile properties of commercial nonwoven fabric .....	193
4.2.12 Tensile properties of woven fabric .....	196

4.2.13 Comparisons of developed hydroentangled nonwoven fabrics with commercial hydroentangled nonwoven and woven fabrics .....	198
4.2.13.1 Comparisons of developed hydroentangled thermal processed nonwoven fabrics with commercial hydroentangled and woven fabrics .....	201
4.2.13.2 Comparisons of developed hydroentangled calendared processed nonwoven fabrics with commercial hydroentangled and woven fabrics .....	202
4.2.14 Air Permeability .....	204
4.2.15 Tearing Test .....	209
4.2.16 Thermophysiological Properties of developed hydroentangled nonwoven fabrics.....	215
4.2.16.1 Thermal Absorption (Dry) .....	215
4.2.16.2 Thermal Absorption (Wet) .....	220
4.2.17 Thermal Resistance (Rct) .....	221
4.2.17.1. Water Vapour Resistance (Ret) .....	225
4.3 Garment Development from developed hydroentangled fabric .....	228
4.4 Summary .....	230
<b>CHAPTER 5 .....</b>	<b>232</b>
<b>Summary and Recommendations for Future Work .....</b>	<b>232</b>
5.1 Summary .....	232
5.1.1 Dimensional Properties .....	234
5.1.2 Bending Rigidity .....	234
5.1.3 Moisture Management .....	235
5.1.4 Tensile Properties .....	235
5.1.5 Air Permeability .....	236
5.1.6 Tearing Property .....	237

5.1.7 Thermophysiological property .....	238
5.2 General Conclusion .....	238
5.3 Recommendations for Future Work .....	240
<b>References .....</b>	<b>243</b>

# List of Figures

## Chapter 2

Figure 2.1 Nonwoven production growth rate in Europe (EDANA 2013) .....	12
Figure 2.2 Applications of nonwoven in different Segmentation in 2012 and 2014 in the Europe, (EDANA 2015) .....	13
Figure 2.3 Tyvek day jacket by American Apparel .....	17
Figure 2.4 Nonwoven wool garments by Canesis Network Ltd .....	18
Figure 2.5 Nonwoven garments designed by University of Leeds (UoL) (INDX 2008) .....	19
Figure 2.6 Manufacturing process of Evolon .....	19
Figure 2.7 Cotton lamination on spunlaying line .....	22
Figure 2.8 structure of wool and Tencel fibres .....	31
Figure 2.9 Types of web produce for nonwoven fabrics .....	37
Figure 2.10 SEM images of carded (A) and Air-laid (B) webs. The scale bars for images A and B are 200 and 500 ( $\mu\text{m}$ ) .....	38
Figure 2.11 Wet-laid web making process .....	39
Figure 2.12 Dry-laid carding process .....	40
Figure 2.13 Air-laid nonwoven process .....	40
Figure 2.14 Schematic diagram of the spun-laid process .....	41
Figure 2.15 Illustration of pre-needling process .....	42
Figure 2.16 Hydroentanglement process .....	44
Figure 2.17 Fibres compression and bonding behaviour under water pressure (Mao and Russell) ...	49
Figure 2.18 Hydroentanglement process supporting media .....	51

## CHAPTER 3

Figure 3.1 The SEM of Polyester (left) and Tencel® fibres (right) in water vapour atmosphere (Lenzinger Berichte, 2006) .....	56
Figure 3.2 Transmission electronic micrographs of cellulosic fibres showing the water absorbing capacity. (Lenzinger Berichte, 2006) .....	57
Figure 3.3 Comparison of surface appearance of Tencel Fibre with wool and Cotton .....	57
Figure 3.4 Pilot needling machine for producing needle punched nonwoven fabrics (university of Bolton) .....	61
Figure 3.5 Dispersion of fibres during needling process .....	63
Figure 3.6 Pilot hydroentanglement machine for producing hydroentangled nonwoven fabric up to 200 bars water pressure (university of Leeds) .....	64

Figure 3.6A Schematic view of pilot hydroentanglement machine .....	64
Figure 3.7 Effect of water pressure on fabric thickness .....	68
Figure 3.8 Carbon paper view of rollers contact .....	69
Figure 3.9 Thermal bonding mechanism of calendaring machine .....	70
Figure 3.10 Pilot thermal bonded machine (university of Bolton) .....	71
Figure 3.11 Thermal Bonding Principles in Thermal Bonding Machine through Infra-Red Rays .....	72
Figure 3.12 Melting point of Bi-components Sheath/Core PE/PET by DSC method .....	73
Figure 3.13 Shirley's flexometer and slider used in fabric bending measurement.....	76
Figure 3.14 Procedure of determining the bending length of the fabric. ....	76
Figure 3.15 Tensile test Instron apparatus .....	77
Figure 3.16 Air Permeability test (Shirley) .....	79
Figure 3.17 Vertical Wicking Apparatus .....	80
Figure 3.18 Absorption Test Method .....	82
Figure 3.19 outside and inner side view of SGHP apparatus .....	84
Figure 3.20 SGHP software for measuring the thermal resistance of the fabric .....	85

## **CHAPTER 4**

Figure 4.1 Flexural rigidity values of base samples in machine and cross directions .....	91
Figure 4.2 SEM of B1 sample showing the entangling behaviour of the fibres in (A) MD and (B) CD .	92
Figure 4.3 Effect of fabric area density on flexural rigidity of the fabrics in MD .....	93
Figure 4.4 Bending Mechanism of Nonwoven Fabric .....	93
Figure 4.5 Flexural rigidity values of base samples after thermal bonding process in MD .....	95
Figure 4.6 Flexural rigidity values of base samples after thermal bonding process in CD .....	95
Figure 4.7 DSC curve of sample B2 before thermal process .....	98
Figure 4.8 DSC curve of sample B2 after thermal process .....	98
Figure 4.9 TGA of Tencel fibres .....	100
Figure 4.10 DSC curves of base samples B1, B2, B3, B4. And B5 before thermal process .....	101
Figure 4.11 DSC curves of base samples B2, B3, B4. And B5 after thermal process .....	102
Figure 4.12 Tensile values of developed base samples in machine directions .....	103
Figure 4.13 SEM of CD region of Base sample B3 for analysing the fibres positions in fabric structure.....	104
Figure 4.14 Tensile values of developed base samples in cross directions .....	104

Figure 4.15 Tensile strength of developed samples with respect of BI .....	106
Figure 4.16 Effect of thermal process on tensile strength in MD of the samples .....	107
Figure 4.17 Effect of thermal process on breaking extension in MD of samples .....	108
Figure 4.18 Thickness of tested fabrics at 1gm/cm <sup>2</sup> and 5gm/cm <sup>2</sup> .....	111
Figure 4.19 Relationship between water pressure and the thickness of the hydroentangled nonwoven fabrics prepared .....	112
Figure 4.20 Area densities of nonwoven and woven fabrics .....	114
Figure 4.21 Effect of jet pressure on bulk densities of the developed hydroentangled fabrics through hybrid process. ....	115
Figure 4.22 Bending behaviour of developed nonwoven, commercial nonwoven and woven fabrics.....	116
Figure 4.23. Needle punched and hydroentangled nonwoven fabric produced at 75 bar showing mechanical bonding behaviour of fibres .....	118
Figure 4.24 Calendered thermal bonding between the fibres .....	119
Figure 4.25 Pre-needled and hydroentangled nonwoven fabric produced at 75 bar hydro pressure showing mechanical bonding between the fibres .....	120
Figure 4.26 Bonding behaviour of filaments in commercial hydroentangled nonwoven fabric .....	121
Figure 4.27 Effect of fabric thickness on the BR in MD of tested fabrics .....	122
Figure 4.28 Effect of area densities on the bending length of tested fabrics .....	125
Figure 4.29 Bending behaviour of nonwoven fabric produced at 50 bar hydro pressure .....	128
Figure 4.30 Microscopic view of the sample produced at 50 bar hydro pressure.....	129
Figure 4.31 Fibres melting behaviour after Calendaring process for flexural rigidity .....	130
Figure 4.33 Bending behaviour of Nonwoven Fabric produced at 75 Bars Hydro Pressure .....	131
Figure 4.34 Microscopic view of sample (produced at 100 bars hydro) after calendaring process ..	133
Figure 4.35 Bending behaviour of Nonwoven Fabric produced at 100 Bars Hydro Pressure .....	133
Figure 4.36 SEM of sample (produced at 125 bars hydro) after calendaring process .....	134
Figure 4.37 Bending behaviour of Nonwoven Fabric produced at 125 Bars Hydro Pressure .....	135
Figure 4.38 Wicking behaviour of nonwoven and woven fabric in machine and cross directions ....	138
Figure 4.39 Wicking height of Developed Nonwoven and References Fabrics in Machine and Cross Directions .....	138
Figure 4.40 Microscopic view of hydroentangled nonwoven fabric produced at 50 bars hydro pressure (0.58mm) .....	140
Figure 4.40a hydroentangle@75 bars .....	141

Figure 4.40b Hydroentangled @125 bars .....	141
Figure 4.40c Calendered Sample S11 .....	142
Figure 4.40d Calendered sample S12 .....	142
Figure 4.40e Woven fabric (1x1 weave) .....	143
Figure 4.40f Evolon 100PK .....	143
Figure 4.40g Hydroentangled @100 bar .....	144
Figure 4.40h Hydroentangled @ 50 bar .....	144
Figure 4.41 Absorption values of woven and nonwoven fabrics .....	146
Figure 4.42a Microscopic view of hydroentangled sample prepared at 50 bars hydro pressure.....	148
Figure 4.42b Microscopic view of Evolon 100 PK .....	150
Figure 4.42c Microscopic view of woven fabric .....	151
Figure 4.43 Effect of fabric density on the absorption of the fabrics at different fabric weight .....	154
Figure 4.44 Effect of fabric thickness on water absorption at different fabric weight .....	156
Figure 4.44a, Co-relation between the thicknesses and the absorption behaviour of the fabrics.....	156
Figure 4.45 Effect of hydroentanglement pressure on the thicknesses of the Fabric .....	159
Figure 4.46 Effect of hydro pressures on the tensile strength of the hydroentanglement fabrics produced through needlepunched process .....	160
Figure 4.46a, Co-relation between hydro pressure and tensile strength of the fabrics in MD .....	161
Figure 4.46b Effect of hydro pressures on the extensibility of the hydroentanglement fabrics produced through needlepunched process .....	162
Figure 4.46c Co-relation between hydro pressure and extensibility of the fabrics in MD .....	163
Figure 4.46d Co-relation between hydro pressure and extensibility of the fabrics in CD .....	163
Figure 4.47 Scanning Electron Microscope (SEM) picture showing the hydroentangled nonwoven fabric produced at 50 bars (size 1.00 mm) .....	164
Figure 4.48 Effect of 50 bars hydro pressure on the tensile properties of the hydroentangled nonwoven fabric .....	165
Figure 4.48a Effect of thermal process on the tensile properties of the hydroentangled nonwoven fabric produced at 50 bars hydro pressure .....	166
Figure 4.49 Optical microscopic picture of calendered fabric produced at 50 bars hydro pressure.	167
Figure 4.49a Effect of calendered process on the tensile properties of the hydroentangled nonwoven fabric produced at 50 bars hydro pressure .....	168
Figure 4.50 Optical microscopic picture of hydroentangled nonwoven fabric produced at 75 bars hydro pressure .....	169

Figure 4.50a Effect of 75 bars hydro pressure on the tensile properties of the hydroentangled nonwoven fabric .....	170
Figure 4.51 Effect of thermal process on the tensile properties of the hydroentangled nonwoven fabric produced at 75 bars hydro pressure .....	171
Figure 4.52 Optical microscopic picture of hydroentangled calendared processed nonwoven fabric.....	172
Figure 4.52a Effect of calendaring process on the tensile properties of the hydroentangled nonwoven fabric produced at 75 bars hydro pressure .....	172
Figure 4.53 Optical microscopic picture of hydroentangled nonwoven fabric produced at 100 bars hydro pressure .....	173
Figure 4.53a Effect of 100 bars hydro pressure on the tensile properties of the hydroentangled nonwoven fabric .....	174
Figure 4.54 Effect of thermal process on the tensile properties of the hydroentangled nonwoven fabric produced at 100 bars hydro pressure .....	175
Figure 4.55 SEM of calendared hydroentangled nonwoven fabric produced at 100 bars hydro pressure .....	176
Figure 4.55a SEM of Calendared hydroentangled nonwoven fabric showing structure of the fabric.....	177
Figure 4.55b Effect of calendaring process on the tensile properties of the hydroentangled nonwoven fabric produced at 100 bars hydro pressure .....	178
Figure 4.56 SEM of hydroentangled nonwoven fabric produced at 125 bars hydro pressure .....	179
Figure 4.56a Effect of 125 bars hydro pressure on the tensile properties of the hydroentangled nonwoven fabric .....	180
Figure 4.57 Effect of thermal process on the tensile properties of the hydroentangled nonwoven fabric produced at 125 bars hydro pressure .....	181
Figure 4.58 SEM of calendared hydroentangled nonwoven fabric produced at 125 bars hydro pressure .....	182
Figure 4.58a Effect of calendaring process on the tensile properties of the hydroentangled nonwoven fabric produced at 125 bars hydro pressure .....	183
Figure 4.59 Microscopic view of hydroentangled nonwoven fabric (without needle punched) produced at 100 bars hydro pressure .....	185
Figure 4.59a Tensile properties of hydroentangled nonwoven fabric produced at 100 bars hydro pressure .....	186
Figure 4.60 Effect of thermal bonding on tensile properties of the fabric .....	187
Figure 4.61 Effect of calendaring process on tensile properties of the fabric .....	188
Figure 4.62 Microscopic view of spunlaced nonwoven fabric produced at 125 bars hydro pressure.....	190



Figure 4.62a Tensile properties of hydroentangled nonwoven fabric produced at 125 bars hydro pressure .....	190
Figure 4.63 Effect of thermal bonding on tensile properties of the fabric .....	192
Figure 4.64 Effect of calendaring process on tensile properties of the fabric .....	192
Figure 4.64a SEM of calendared hydroentangled nonwoven fabric produced at 125 bars hydro pressure .....	193
Figure 4.65 Microscopic view of commercial nonwoven fabric .....	195
Figure 4.65a Tensile properties of commercially available hydroentangled nonwoven fabric .....	195
Figure 4.66 Microscopic view of commercially available woven fabric (plain weave) .....	196
Figure 4.66a. Tensile properties of woven fabric in machine and cross direction .....	197
Figure 4.67 Comparisons of tensile strengths in MD of different hydroentangled nonwoven fabrics produced at different hydro pressures with commercial hydroentangled and woven fabrics .....	199
Figure 4.68 Comparisons of tensile strengths in CD of different hydroentangled nonwoven fabrics produced at different hydro pressures with commercial hydroentangled and woven fabrics .....	200
Figure 4.69 Comparisons of tensile strengths in MD of different hydroentangled thermal processed nonwoven fabrics produced at different hydro pressures with commercial hydroentangled and woven fabrics .....	201
Figure 4.70 Comparisons of tensile strengths in CD of different hydroentangled thermal processed nonwoven fabrics produced at different hydro pressures with commercial hydroentangled and woven fabrics .....	202
Figure 4.71 Comparisons of tensile strengths in MD of different hydroentangled calendared processed nonwoven fabrics produced at different hydro pressures with commercial hydroentangled and woven fabrics .....	203
Figure 4.72 Comparisons of tensile strengths in CD of different hydroentangled calendared processed nonwoven fabrics produced at different hydro pressures with commercial hydroentangled and woven fabrics .....	204
Figure 4.73 Effects of finishing processes on the air permeability values of the hydroentangled nonwoven fabric produced at 125 bars hydro pressure .....	206
Figure 4.74 Topical view of developed hydroentangled (B), commercial hydroentangled (A) and woven (C) fabric structures obtained by SEM at 1mm size .....	207
Figure 4.75 Comparison of air permeability values of developed hydroentangled nonwoven fabrics with commercial hydroentangled and woven fabrics .....	208
Figure 4.76 Comparison of fabrics air permeability with fabrics densities .....	209
Figure 4.77 Tearing strength of developed hydroentangled nonwoven fabrics produced at 125 bars and compared with commercial hydroentangled nonwoven fabric .....	211
Figure 4.78 Tearing resistance of developed hydroentangled nonwoven fabrics produced at 125 bars and compared with commercial hydroentangled nonwoven fabric .....	213

Figure 4.79 Comparison tearing resistance of developed and commercial hydroentangled nonwoven fabric with fabric density in CD .....	214
Figure 4.80 Comparison tearing resistance of developed and commercial hydroentangled nonwoven fabric with fabric density in MD .....	215
Figure 4.81 Microscopic view of developed hydroentangled fabric at 125 bars hydro pressure .....	216
Figure 4.82 Thermal absorption of developed hydroentangled, commercial and reference fabric in dry and wet state .....	217
Figure 4.83 Effect of fabric density on the thermal absorptivity of the developed and commercial hydroentangled and woven fabric in dry condition .....	218
Figure 4.84 Structural compactness of developed and commercial hydroentangled nonwoven fabrics by SEM .....	219
Figure 4.85 Thermal comfort technique of developed hydroentangled fabric through air permeability process .....	220
Figure 4.86 Effect of Absorption properties on the thermal absorptivity of the (A) Developed, (B) Commercial and (C) woven fabrics .....	220
Figure 4.87 Thermal resistance of developed, commercial and woven fabrics in dry and wet state.	222
Figure 4.88 SEM structure of developed hydroentangled fabric .....	223
Figure 4.89 Thermal resistances of developed and commercial fabrics by SGHP .....	224
Figure 4.90 Water vapour resistances of developed and commercial hydroentangled fabrics by SGHP method .....	226
Figure 4.91 Effects of fabric thicknesses on the water vapour resistance .....	227
Figure 4.92 Effects of fabric bulk density on the water vapour resistance .....	227
Figure 4.93 Dyed hydroentangled Nonwoven Shirt and types of stitches made by developed hydroentangled fabric .....	229

## List of Tables

### Chapter 3

Table 3.1 Tensile properties of Tencel fibres and comparison with other fibres .....	58
Table 3.2 Specifications of Tencel and Bi-component Fibres .....	59
Table 3.3 Specifications of needling and light needling of needle punch machine .....	62
Table 3.4 Hydroentanglement Machine Specifications .....	65
Table 3.5 Calculated Specific Energy based on different water pressure during hydroentanglement.....	68
Table 3.6 Specification of Calendaring Machine .....	69
Table 3.7 Specifications of thermal bonded machine .....	72

### CHAPTER 4

Table 4.1 List of the fabrics investigated in this study .....	88
Table 4.2 Dimensional and Flexural Rigidity properties of Base samples .....	91
Table 4.3 DSC, Heat of fusion of base samples before and after thermal process .....	96
Table 4.4 Bonding Index (BI) of developed samples .....	105
Table 4.5 Dimensional properties of nonwoven fabrics prepared .....	109
Table 4.6 Details of Tested samples .....	113
Table 4.7 Bending rigidity values of fabrics studied .....	117
Table 4.8 Details of fabric thickness versus bending rigidities of tested fabrics .....	124
Table 4.9 Bending length and fabric weight (g/m <sup>2</sup> ) of tested fabrics .....	127
Table 4.10 Physical Properties of the Fabrics .....	137
Table 4.11 Samples Details .....	147
Table 4.12 Details for tested samples for absorption test .....	152
Table 4.13 Details of tested samples for absorption in term of thickness .....	154
Table 4.14 Characteristics of tested fabric samples .....	198
Table: 4.15 Air Permeability values of the developed hydroentangled nonwoven and references fabric samples .....	205
Table 4.16 Characteristics of the developed hydroentangled nonwoven and reference fabrics samples .....	205
Table 4.17. Tearing strength values of developed and control fabrics in machine and cross directions.....	210

Table 4.18, Tearing resistance values of developed and control fabrics in machine and cross directions .....212

Table 4.19 comparison of thermal absorption of developed hydroentangled fabrics with commercial and reference fabrics.....216

Table 4.20 Thermal Absorption and Thermal Resistance of developed hydroentangled fabrics before and after thermal bonded process .....225

## List of Acronyms

INDA	International Nonwoven & Disposable Association (Association of Nonwoven fabrics Industry)
EDANA	European Disposable and Nonwoven Association
SMS	Spunlaid/Meltblown/Spunlaid
FR	Flame Retardant
WRONZ	Wool Research Organization New Zealand
AWI	Australian Wool Innovation
PE	Polyethylene
PP	Polypropylene
MD	Machine Direction
CD	Cross Direction
PET	Polyethylene terephthalate
SEM	Scanning Electron Microscope
dtex	Deci-tex (Fibre count)
g/m <sup>2</sup>	Gram per meter square (Fabric mass)
DSC	Differential Scanning Calorimetry
TGA	Thermogravimetric Analysis
SGHP	Sweat Guard Hotplate
R <sub>ct</sub>	Thermal Resistance
R <sub>et</sub>	Water Vapour Resistance
H <sub>E</sub>	Heat of Fusion
X <sub>C</sub>	Crystallinity
BI	Bonding Index
FAD	Fabric Area Density

FBD	Fabric Bulk Density
NP-HE	Needle Punched and Hydroentanglement
LP-HE	Light needle Punched (pre-needling) and Hydroentanglement
E1	Evolon® fabric
W1	Woven fabric
BR	Bending Rigidity
GSM	Gram per square meter
SD	Standard Deviation
ASTM	American Standard Test Method
$\eta$	Shape factor, dimensionless
E	Fibre specific modulus, N*m/kg
T	Fibre linear density, kg/m
P	Fibre density, kg/m <sup>3</sup>
$\rho_w$	density of water (1000 kgm <sup>-3</sup> )
$\rho_f$	fibre density (kgm <sup>-3</sup> )
n	number of jets per unit length in a water jet strip (ends/m)
$C_d$	water flow discharge coefficient (0.66)
D	diameter of the orifice (m)
m	area density of the web (kgm <sup>-2</sup> )
$d_f$	fibre diameter (m)
y	deflection depth of fibre (m)
V <sub>b</sub>	belt speed (m/s)
p	hydrostatic pressure drop per jet (Nm <sup>-2</sup> )

$d_x$	diameter of a water jet stream on the surface of the web (m)
$E$	young's modulus of the fibre ( $\text{Nm}^{-2}$ )
$K_2$	kinetic energy of water jets
$E$	energy/mass of web
$p_i$	Water pressure (bar)
$C_d$	Co-efficient of discharge
$d_i$	Diameter of jet orifices (m)
$W$	Web area density ( $\text{kg/m}^2$ )
$n_i$	Number of jet orifices/metre
$S$	Delivery speed (m/s)
$V_1$	Jet Velocity (m/sec)
$P_1$	Pressure in Pa (1bar = $10^5$ Pa)
$\rho$	Density of water $998.2 \text{ kg/m}^3$
$d$	Diameter of orifice in metre
$\rho$	Density of Water ( $\text{kg/m}^3$ )
$C_d$	Coefficient of discharge
$V$	Jet Velocity (m/sec)
$E$	Energy Rate (J/s)
$M$	Mass flow rate of the fabric in kg/sec
$M$	Mass per unit area of fabric ( $\text{g/m}^2$ )
$C$	Bending length (cm)
$m_1$	Dry weight of fabric (g)
$m_2$	Wet weight of fabric (g)

h	wicking height (mm)
h <sub>2</sub>	Specimen strip length after wicking test (mm)
h <sub>1</sub>	Specimen strip length before wicking (mm)
F	Tearing force (gf)
R	Scale reading
C	Full scale Capacity (gf)
P	capillary pressure,
Y	surface tension of the wetting liquid,
θ	contact angle
r	radius of the capillary



# Chapter 1

## Introduction to Nonwoven Apparel

### 1.1 Introduction

The conventional methods of producing the apparel fabrics are lengthy and costly. These methods involve a series of complex processes; starting from the ginning process to the spinning for yarn manufacturing and then only after weaving or knitting the fabric becomes available for garment manufacture. Therefore, the production of apparel fabric using the conventional routes requires a considerable amount of investment in the infrastructure, labour, and energy. The complexity and material processing requirements of these methods also have detrimental effect on the environment.

In contrast, the fabrics produced through the nonwoven methods are more efficient and cost-effective because in this case, the fabrics are produced directly from the fibres. Nonwoven fabrics have commonly been disadvantaged when they are compared with the knitted or woven fabrics in terms of their aesthetic and technical properties, such as softness, durability, stretchability, drapability and surface abrasion. The nonwoven fabrics must exhibit such characteristics if they are going to be suitable for the production of garments, particularly for demanding applications, such as fashion apparel.

There are two types of nonwovens in the market, durable and disposable. Durable nonwoven fabrics can be used for the apparel purposes. The durable nonwoven fabric grew from \$15.3 billion to \$20.6 billion tonnes at an annual growth rate of 6.1% from 2008 to 2013 and it is forecasting to 6.7% in 2018 (1)

The apparel industry in term of garment manufacturing is rapidly growing and it is one of the most globalised industries in the world. The growth rate of the apparel production in the world is estimated at 8.2% for the period of 2011-2017 (2).

Because of the tough market competition, many manufacturers and research organisations are trying to adopt new technologies and materials in order to sustain their market share. Furthermore, development and introduction of innovative products in the apparel market will allow companies to capture a larger share of the market.

Because of the competitive pressures, companies are trying to explore the non-conventional methods to produce fabrics for apparel applications in order to innovate and reduce costs. A considerable research effort is in progress for the enhancement of the properties and characteristics of the non-conventional fabrics such as nonwoven fabrics, fabrics development through spray technology, so that they can be used in the apparel industry.

Recently, the textile industry has taken a keen interest in the applications of nonwovens in apparel applications because of the ease and high speed of their manufacturing processes and cost-effectiveness. Due to their simplicity, the nonwoven production processes can respond to the market demand quickly and this is an important aspect of the apparel fashion industry. Because of these factors, the nonwoven production now is gaining a growing share of the fashion and functional clothing market at the cost of the knitted and woven fabrics, for example, nonwoven share in apparel market increased from 0.70% to 0.76% from 2012 to 2014 (EDANA 2015). Therefore, nonwoven fabrics, as non-conventional fabrics, are the innovation-adoption materials that are being developed for the fashion conscious consumer (3).

Nonwoven industry production line speeds (10-100m/min) are considerably faster than the weaving (1-2 m/min) and knitting (2-5 m/min) lines and these production comparisons look impressive from nonwoven fabric's viewpoint, thus giving a competitive edge to nonwovens in terms of unit cost in the apparel industry (4).

For decades, nonwovens have been used as supporting materials in the clothing industry and as such they have been used as fusible interlinings and reinforcements for collars and cuffs. It was assumed that nonwovens are disposable and relatively rigid structures and they do not have the attributes that can promote them in the clothing industry as the outer fabrics. However, because of the advancements in technology and materials, the perception of disposable and rigidity of the nonwovens has changed in recent years with the development of the commercially available nonwoven fabric "Evolon". Evolon is one of the best high-tech nonwovens that are being used as apparel outer fabric. It was made through spunlaying and hydroentanglement process by using island in the sea splittable bi-component PET and PA filament fibres (5). Ultrafine filaments of bicomponent fibres effect on some

properties of the fabric such as breathability, moisture management and thermal properties, as mentioned in Chapter 4.

Besides Evolon, there are other commercial nonwoven fabrics that have entered the clothing industry and the most well-known are “Miratec” from PGI (the U.S.) and “Inova” from DuPont (the U.S.). “Miratec” nonwoven fabric is used in the Nike’s undershirts and it was also used by Futon fabric (6).

The appearance of Evolon fabrics are not like as woven structure because the filaments are scattered in different directions that add odd appearance of the fabric and secondly the hand feel is little harsh as compared with woven fabric. After evaluating the mechanical and aesthetical tests, it is found that because of micro filaments, the air permeability is very low that can be uncomfortable for the wearer during physical activities. Secondly, the flexural rigidity is very high as compared with woven fabrics. Because of higher flexural rigidity, it will give harsh feeling to the skin. There are other new nonwovens such as Tyvek by DuPont that are made by thermal bonding of spunbonded PE. These kind of fabrics can be used only for protective clothing purpose but these fabrics cannot be used as outer fabric next to the skin because the fabric structure resists for use as casual garments. There are lot of examples of current nonwoven fabrics that are being used in the protective clothing industry, so there are the space to find out the different kind of nonwoven fabric that can be suitable for garments purposes and can be used in replacement of woven fabrics and can be used as outer fabrics next to skin for casual garment industry.

There are some attributes that the apparel clothing must possess and these include drape, hand feel, pilling, stretch & recovery, durability and texture. A great deal of research is in progress in order to impart these characteristics to the nonwoven structures and, as pointed out above, some important developments have taken place in recent years and nonwoven fabrics (such as Evolon and Miratech etc.) have been successfully marketed for apparel applications.

The focus of this study is on the development of nonwoven fabrics that can mimic the essential characteristics of apparel fabrics. This study will identify and determine the best possible methods or systems which can lead to the production of nonwoven fabrics that would be acceptable as apparel clothing with regard to the major attributes as mentioned above. Appearance is directly related to the serviceability of the fabric.

Fabric's aesthetical properties could be altered because of the forces of work or wearer, these forces could be abrasion, washing, effect of dry and wet and weather condition, etc. Therefore, during the development of the new fabrics, these important aspects must be considered.

Woven fabric's structure is based on the well-defined features and is expected to fulfil all the basic requirements of the clothing industry, especially the durability requirements. It is known that the basic component that assures the durability of a woven fabric, is the strength of the yarns used. On the other hand, conventional nonwoven fabrics comprise of a random structure and the main components that contribute to the strength of the nonwoven fabric are short staple fibres instead of the yarn, and the fabric is expected to show weakness in its structure. Therefore, it is obvious that for the development of a durable nonwoven fabric, two factors are important, one is the selection of appropriate materials and the second is the use of a suitable method of making the nonwoven fabric.

## **1.2 Purpose of this study**

The purpose of this study was to explore new materials and processes for the production of nonwoven fabrics for apparel applications that can fulfil the standards of the clothing industry. For this reason, an intensive literature review related to the nonwovens for apparel applications was conducted and the shortcomings of the current nonwovens were highlighted in order to select the right materials and methods for the production of durable nonwoven fabrics that meet the criteria for the apparel clothing industry. The literature review provided the guidelines for the development of durable nonwoven fabrics that can be used in the apparel industry as functional clothing. The research proposal was developed based on the following main points:

1. Identification and selection of innovative and sustainable materials that are suitable for the development of functional nonwoven fabrics for apparel applications.
2. Development of a practical and cost-effective manufacturing process for the production of durable nonwoven fabrics that possesses the desired characteristics, both aesthetic and functional, for apparel industry.
3. Characterisation and evaluation of the developed nonwoven fabrics by using standard test methods and procedures used for the apparel fabrics, so that the

nonwovens could be directly compared with their woven counterparts. Furthermore, the developed nonwovens will be compared with the commercially available nonwovens that are currently being used as the alternatives to the woven fabrics in specific applications.

### **1.3 Significance of this study**

Traditionally, nonwovens are used in medical and industrial sectors and a very limited part of the nonwovens produced was in the apparel industry in the form of interlinings and fusing because of their limitations. Mostly manufacturers and designers had a negative approach toward the nonwoven fabrics because of their rigidity and also the lack of tactile feeling.

However, as a result of the extensive research carried out on nonwoven assemblies, now researchers have been developed unique and innovative nonwoven fabrics that has changed the perception of the manufacturers and designers about the usage of the nonwoven. Now the big brands use limited amount of nonwovens in their product lines, for example, a famous brand in the USA (American Apparel) use Tyvek nonwoven as the outer fabric in their jacket products.

The work carried out in this research will enhance the importance of nonwoven fabrics in the apparel industry and can provide new opportunities for the application nonwovens in the fashion industry. This research will focus on these attributes and will aim to produce nonwoven fabrics that are fit for the apparel industry, especially for the fashion wear applications.

### **1.4 Scope of this study**

The main focus of this study was to develop innovative nonwoven fabrics through the judicious use of the currently available materials and the nonwoven production processes. It appears that the hydroentanglement or spunlace technology is very favourable for the development of durable and aesthetically acceptable nonwoven fabrics for apparel applications because, it imparts the acceptable aesthetic and mechanical properties in the developed fabric than other nonwoven bonding techniques. Two types of innovative raw material were used; very fine bi-component sheath/core (PE/PET) fibre and Tencel fibre. The purpose of the bi-component fibres is to strengthen the hydroentangled fabrics after thermal bonding process.

These two fibres were blended in a specific ratio in order to obtain the optimum blend for the production of a durable and functional nonwoven fabric for apparel use.

The fabrics were made by using two different approaches. In the first approach, a hybrid process was employed in which the fibrous web was passed through the needlepunching process and then the needlepunched fabric was further consolidated through the hydroentanglement process, where fibres were further mechanically bonded in the form of durable nonwoven fabric.

In the second approach, the fibrous web was directly passed through the hydroentanglement process after pre-needle process. Different types of nonwoven fabrics were prepared by using different hydro pressures and the resultant fabrics were fully characterised in order to determine their suitability for apparel applications.

The developed nonwoven fabrics were expected to exhibit the following novel properties:

- a) High strength in MD, for durability to multiple washes (reusable).
- b) Breathable because of its porous structure, so that it is comfortable during wearing.
- c) Improved hand feel as compared to the existing nonwoven fabrics.
- d) Improved printability without any detrimental effect on the breathability of the nonwoven fabrics.

Furthermore, it is expected that the novel nonwoven fabrics can be used for many applications including:

- a) Short and medium life fashion garment applications.
- b) Aprons and gowns for hygiene kitchens, hospital persons, care homes and fast food restaurant etc.

## **1.5 Thesis structure**

This work is divided into 5 different chapters as given below:

### **Chapter 1**

Chapter one contains the basic information related to the conventional methods of producing the apparel fabrics and highlights the costs that are incurred during the production of woven and knitted fabrics. It also contains the explanation about

unconventional method of producing the apparel type fabrics at lower costs and points out the basic problems due to which there are limited applications of nonwoven fabrics in the apparel industry. The significance and scope of this research is also described in this chapter.

## Chapter 2

This part describes a detailed literature review about the development of nonwoven fabrics for clothing in the past and highlights the drawbacks of the existing nonwoven fabrics for apparel purposes. The chapter also contains the details of the desired properties of a nonwoven fabric for apparel applications. The chapter is concluded with the description of the processes involved in the development of apparel type nonwovens.

## Chapter 3

Chapter 3 contains the information about the characteristics of materials and methods that are used for the development and evaluation of the novel nonwoven fabrics. The equipment and test methods used in this study are fully described and where appropriate, the tests are performed according to the relevant British Standards Test Methods.

## Chapter 4

Chapter 4 contains all the results obtained for the developed nonwoven fabrics and the reference nonwoven and woven fabrics. The results are fully discussed in the light of current literature. The following tests were performed on the developed nonwovens and the reference fabrics:

1. Dimensional properties.
2. Tensile test.
3. Flexural rigidity test.
4. Air permeability test.
5. Absorption and wicking test.
6. Tearing test.
7. Thermal resistance test.
8. Water vapour resistance test.
9. SEM.
10. DSC.

11. TGA.

12. Microscopic analysis.

## Chapter 5

Chapter 5 contains the summary and the overall conclusions of the study and the important findings of the research are highlighted. The chapter also contains proposals for the further work that should be carried out in order to further improve or enhance the properties of the nonwoven fabrics for apparel applications.

### **1.6 Summary**

The conventional methods of producing apparel fabric are expensive because of its lengthy and labourer processes. On the other side, the fabrics produce from the nonwoven techniques are less expensive and more productive than conventional methods. Such as, the production rate of woven fabric is 1-2 meter per minute and production rate of producing fabrics through nonwoven technique is 10-100 meters per minute. Historically, there were some drawbacks of nonwoven fabric in term of aesthetical properties such as handle, structure and appearance. But now because of advancement in technology and materials researchers have been produced some functional nonwoven fabrics like Evolon. There are still gaps of improvement in the current nonwoven fabrics for attaining a significant share in the apparel sectors.

The basics purpose of this study was to identify the basic requirements of the apparel fabrics and to analysis the current available nonwoven fabrics and find out the gaps for improving the functionality and serviceability of the nonwoven fabrics in apparel sectors. This study will identify and determine the best possible methods or systems which can lead to the production of nonwoven fabrics that would be acceptable as apparel clothing with regard to the major attributes like hand feel, drape, durability and texture. This research focusses on three possible ways like:

1. Identification and selection of innovative and sustainable materials that are suitable for the development of functional nonwoven fabrics for apparel applications.
2. Development of a practical and cost-effective manufacturing process for the production of durable nonwoven fabrics that possesses the desired characteristics, both aesthetic and functional, for apparel industry.



3. Characterisation and evaluation of the developed nonwoven fabrics by using standard test methods and procedures used for the apparel fabrics so that the nonwovens could be directly compared with their woven counterparts. Furthermore, the developed nonwovens will be compared with the commercially available nonwovens that are currently being used as the alternatives to the woven fabrics in specific applications.

It was assumed that nonwoven can be used as a supportive material like interlining and fusing in the apparel sectors. But now, as mentioned earlier, nonwoven is entering in the apparel sector as outer fabrics and still research is being carried out for betterment in the nonwoven fabrics to compete the woven fabric.

The work carried out in this research enhanced the importance of nonwoven fabrics in the apparel industry and can provide new opportunities for the application nonwovens in the fashion industry. This research focused on these attributes and aimed to produce nonwoven fabrics that are fit for the apparel industry, especially for the fashion wear applications.

The developed nonwoven fabrics were expected to exhibit the following novel properties:

- a) High strength in MD, for durability to multiple washes (reusable).
- b) Breathable because of its porous structure, so that it is comfortable during wearing.
- c) Improved hand feel as compared to the existing nonwoven fabrics.
- d) Improved printability without any detrimental effect on the breathability of the nonwoven fabrics.

Furthermore, it is expected that the novel nonwoven fabrics can be used for many applications including:

- a) Short and medium life fashion garment applications.

## Chapter 2

### Literature Review

#### 2.0 Introduction

The literature review is comprised of two parts. The first part focuses on the historical and technological developments of nonwoven materials in different markets, especially those in the apparel sector. The second part explores the fundamental requirements for the garments in term of nonwovens and also describes the technical requirements for the nonwoven materials and processes required for garment manufacturing. At the end of the literature review, some gaps in the nonwoven production have been identified in order to improve the properties of nonwovens for apparel applications.

#### 2.1 Historical background: Nonwovens in apparel applications

Nonwoven fabrics are one of the oldest known types of fibrous assemblies and fibrous network structures that were made from papyrus by the ancient Egyptian in 2400 BC. The oldest fabric pieces were found in 1500-1000 BC. Felt, a type of nonwoven, was found nearly 3500 years ago in Scandinavia (7). A British Patent filed in 1853 claims the invention of the nonwoven technique, which used cards, conveyor belting and impregnation (7).

Nonwovens are made directly from the fibres without making any yarn and without the use of weaving or knitting processes. A nonwoven is defined by INDA as follows:

“Sheet or web structure bonded together by entangling fibres or filaments, by various mechanical, thermal and/or chemical processes. These are made directly from the separate fibres or from molten plastic or plastic film”.

The unique advantage of the nonwoven fabric manufacture is that it is a continuously linked process, in which at the first stage raw materials (fibres) are converted into webs via the carding process and at the second stage these fibrous webs are bonded into finished products (8). As mentioned, in Chapter 1, the manufacturing cost related to the nonwoven manufacturing process is very low as compared to the traditional textile manufacturing processes such as weaving and knitting.

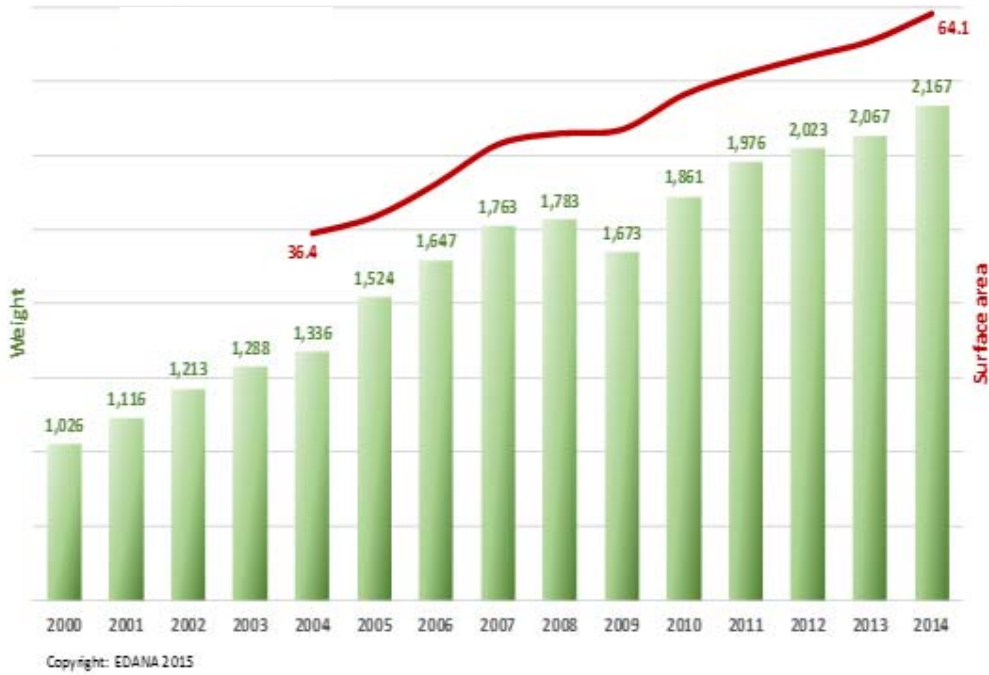
Because of the mass production approach, the nonwoven industry produces enormous varieties of different types of fabrics for myriad applications. Nonwoven products range from single use wet wipes to the highly durable geo-membranes and geotextiles, used in road making process. Nonwoven fabrics therefore have entered many industrial sectors and are used in healthcare and consumer products, which extend from the single use disposable items to the highly durable products like synthetic leather (8).

There are different types of nonwovens, for example, nonwovens with limited life, single-use or durable fabrics. The applications of the nonwovens depend on the specific functions of the nonwoven fabric such as absorbency, resilience, stretch, softness, strength, filtering, bacterial barriers and sterility. These properties are engineered in the fabric according to the demand of the end–use application. The conventional usages of the nonwoven fabrics are in medical (gowns, bandages, and towel), wipes (food services, industrial) disposable apparel, home furnishings, apparel interlining, household and personal wipes, hygiene products, laundry aids, roofing, tags and upholstery (9). Mostly, applications of nonwoven are as disposable products; however, they are used as interlining and interfacing fabrics. Interfacing is part of the garment during stitching process in term of giving stiffness in collars, cuffs, waistband and part of button holes.

With the passage of time, the applications of nonwoven fabrics have increased, although the successful penetration into the apparel sector has been rather limited. Since the 1960s, there have been a few attempts to market disposable dresses, but with little success (10). It appears that the main barrier is related such as ill fit, poor strength and nonwovens do not provide thermophysiological comfort characteristics similar to those of the traditional textiles used for the apparel fabrics. In the early 1970s, different companies such as Kimberly-Clark, Riegel Paper, and Electrolux focused on the improvement in web handling and other means to enhance the performance of the nonwoven fabrics (11). In 1980s and 1990s, research expanded to find ways that would make the nonwoven fabric material more efficient through the process of technology innovation.

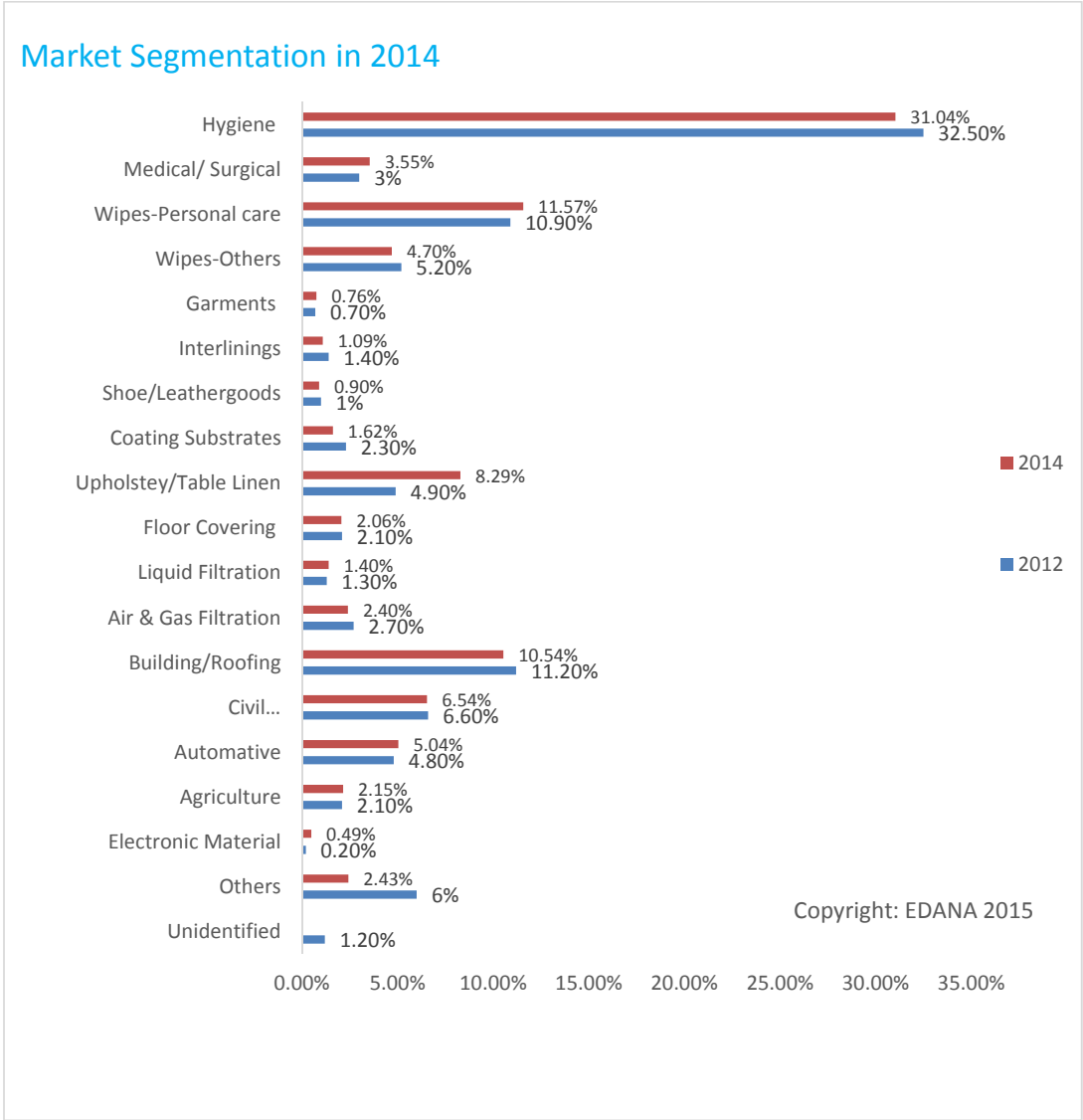
The cumulative growth rate of nonwoven fabrics in Europe has increased to 4.8% in 2014 as compared with 2.2% in 2013 and 2.4% in 2012, as shown in Figure 2.1 (12).

It shows that the demand for the nonwoven materials is growing year by year and they are capturing more markets because of their innovative approach of producing new products. It is also visible that the growth rate is higher in 2014 by 2.4% as compared with 2013 and 2012. This increase is mainly due to the fact that new advancements in technology and materials for the production of nonwoven fabrics have taken place.



**Figure 2.1** Nonwoven production growth rate in Europe<sup>12</sup>

Figure 2.2 illustrates the market segment growth in nonwovens during the period of 2012-2014 in Europe. It can be clearly seen that there is slight incremental growth of nonwoven in the garment market during this period, which is 0.76% in 2014 as compared with 0.70% in 2013 (12). Nonwoven applications as interlinings has decreased from 1.40% in 2012 to 1.09% in 2014. The growth of nonwovens is mainly in the hygiene, wipes and civil engineering segments during 2012-2014 period. The personal wipes' market expanded from 10.90% to 11.57% and the hygiene market slightly decreased from 32.50% to 31.04%.



**Figure 2.2** Applications of nonwoven fabrics in different segments in 2012 and 2014 in EU countries<sup>12</sup>

A major technology that has been applied for the production of nonwoven fabrics, especially in hygienic products, intended for clothing is the hydroentanglement process. According to INDA and EDANA, the growth rate of this technology has increased from 11% in 1994 to 21% in 2004 showing that the growth rate of hydroentangled technology was increased by 91% and it is reflecting the fact that many producers shifted from thermal or chemical bonding technologies toward the hydroentangling technology (13). Historically, medical protective clothing, such as gowns, has been produced from the hydroentangled fabrics. These fabrics compete

in the medical field with woven gowns and spunlaid/meltblown/spunlaid (SMS) constructions (13).

The hydroentanglement process is carried out on the fibrous web in a water pressure range of 10 to 400 bars. Very fine nozzles are used for this purpose, whose diameter ranges from 80 to 150  $\mu\text{m}$ . These cone shaped nozzles are placed on a thin jet strip equal to the machine width (8). Recent regulatory change in Europe, coupled with the concerns about cross-infection and accompanied by the potential of elimination of washing to remove pathogens, has led to an increase in the market share of nonwovens in a number of sectors (14). There remains a significant opportunity for nonwovens to enter in the durable and semi-durable clothing markets as well as to lead the developments in the emerging environmentally sustainable single-use consumer wear sector. Single use nonwoven fabrics, such as aprons and protective clothing, have already been brought to the market, which are mainly intended for business travel and some casual wear. (15).

In order to seize this opportunity in the apparel market, several developments have been made in the nonwoven fabric production technology. One of the most suitable nonwoven technologies for apparel applications is based on the hydroentanglement process. Nonwoven fabrics of particular interest for the durable fabric market are those that are made from split-able bi-component fibres. This technology is still developing and the fabrics produced by this technology have demonstrated apparel-like characteristics that are arguably equivalent to those of the conventional apparel textiles in respect of the mechanical and aesthetical properties, with the exception of drape.

Many companies, such as PGI, DuPont and Freudenberg, have attempted to commercialise nonwoven materials as replacements for the traditional textiles that are used in clothing applications. These include the well-known Evolon (Freudenberg) and Miratech (PGI) nonwoven fabrics that are produced by using the hydroentanglement technology, coupled with either spunbond or dry laid web formation, respectively. The apparel market is a growing market in the world and there is a continual interest in the development of new fabrics in this market, particularly those that can provide some useful combination of functionalities.

It is quite apparent that the nonwoven segment is a fast growing part of the global textile sector because of the diversification in the apparel sector and the development of technical textiles ranging from baby napkin to geotextiles. In the past, nonwoven fabrics have been used as disposable garments or as the interlinings for garments. With the passage of time, the applications of nonwoven fabrics have increased although the successful penetration into clothing market has been rather limited.

The first nonwoven apparel fabric was the disposable paper clothing that was launched in early 1966 by an American company Scott Paper, however, the fabric could not capture any significant part of the apparel market because of its ill fit and uncomfortable nature. In the same era, Mars Manufacturing Company invented different types of nonwoven dresses that were used as evening wear and wedding gowns. However, these all-paper-clothing were short-lived and became obsolete in 1968 (16).

In 1970, Toray Industries developed the world's first ultra-micro nonwoven fabric known as Ultrasuede®. Ultrasuede® was made by using the micro fibres known as "island in the sea", through a series of processes including needlepunching and other complex processes, such as ironing, curling, cutting, etc. The nonwoven fabric was used in apparel, automotive, industrial and interior design applications (17). Ultrasuede® is used mainly in leather-textured products in the automotive industry. Because of its suede structure, the fabric is not suitable for clothing purposes in casual wear.

In the early nineties, Kimberly-Clark introduced a new product with the name of "Demique". It was an elastic nonwoven fabric, which was produced by the thermoplastic micro fibre based on co-polyetheresters. The elastic nonwoven fabric was used in various personal care products such as diapers and feminine hygiene products (18). The fabric was also used in stretchable bed sheets as a composite with cotton/polyester woven fabric. Because of its elastic nature, poor breathability and thermophysiological properties, this fabric is not suitable for apparel applications.

Kimberly-Clark Corporation also invented a laminated nonwoven fabric that was used as a recreational fabric in the manufacturing of outer garments. The laminate was composed of an outer spunbond layer, which provided resistance to ultraviolet radiation and an inner layer, composed of microporous meltblown structure, which

provided the resistance to liquid strike-through. The resultant laminated nonwoven fabric had unique functionalities, such as water proofness and flame retardancy (19)

Carl Freudenberg invented a nonwoven fabric, which had the appearance of a woven fabric. The fabric was made by using 60% polyethylene terephthalate and 40% polybutylene terephthalate fibres through the thermal bonding technique with the application of a bonding agent. The purpose of this invention was to use the nonwoven as a lining material, which also showed high abrasion resistance and allowed the fabric to retain its shape in all directions (20).

At the end of the last century, Kimberly-Clark launched a nonwoven protective clothing with the trade name of KLEENGUARD®. This fabric was made by using thermoplastic fibres and thermoplastic filaments via the meltblown and spunbond processes. A meltblown web of the thermoplastic microfibres was sandwiched between the two spunbond layers of the thermoplastic filaments (SMS), which resulted in a durable nonwoven fabric (21).

In 2003, Kuraray invented a composite protective nonwoven fabric composed of three layers as given below:

- (A) Water resistant nonwoven fabric made from polyolefin-based ultra-fine fibres.
- (B) Heat-bonded nonwoven fabric made from thermoplastic elastomer ultra-fine fibres.
- (C) Permeable nonwoven fabric.

Fabric B was inserted between the fabrics A and C for integral bonding of each fabric. The resultant fabric showed high strength and was suitable for protective clothing applications (22).

Kimberly-Clark invented a breathable composite nonwoven fabric based on three layers which were:

- (1) Low strength nonwoven web containing polyolefin fibres.
- (2) High strength nonwoven web containing polyamide fibres.
- (3) Water impermeable barrier layer positioned between these two layers.



These webs were then passed through the thermal bonding process for creating thermal bonding between the nonwoven webs. The resultant nonwoven composite fabric was suitable for protective clothing (23).

A durable, fire resistant, launderable, comfortable and inexpensive nonwoven composite fabric was developed in the USA (24). It was designed to replace the traditional woven uniform used by the military personnel. The nonwoven composite fabric performed much better than the woven military uniform in terms of the mechanical and physical properties. The nonwoven fabric was produced by binding three different layers through the hydroentanglement process. The two outer layers were comprised of polyamide and cotton fibres and the middle layer was a loose knitted fabric that was sandwiched between the two outer layers. These layers were first hydroentangled then flame retardant (FR) and other chemicals were applied at the finishing stage for achieving an improved durable nonwoven fabric. DuPont has developed a range of strong nonwoven products under the trademark of Tyvek®. The products are in the forms of paper, film and fabric and are made from thermal bonding of spunbonded polyethylene. Tyvek® possesses high abrasion and puncture resistance, smooth surface, high tearing strength, lightweight and good dimension stability. The fabric is mainly used in the construction and medical sectors as protective clothing and protective cover applications (25). Because of Tyvek's finishing properties like water and wind proof, the fabric is also used in many consumer applications as a protective material. A good example is the use of the fabric by American Apparel Company in Tyvek jacket (Figure 2.3), which is an outerwear and has received a very impressive response from the customers (26). However, the heat bonded fabric made of non-absorbent polyethylene does not absorb moisture and therefore it is not used in direct skin contact garment applications.



**Figure 2.3** Tyvek Day Jacket by American Apparel<sup>26</sup>

Canesis Network Ltd was established in 1961 by The Wool Research Organisation of New Zealand (WRONZ). They have developed a lightweight apparel nonwoven fabric

made from 100% wool and after some finishing, it showed unique properties and the fabric was found to be suitable in fashion apparel applications as shown in Figure 2.4 (27).



**Figure 2.4** Nonwoven wool garments by Canesis Network Ltd<sup>34</sup>

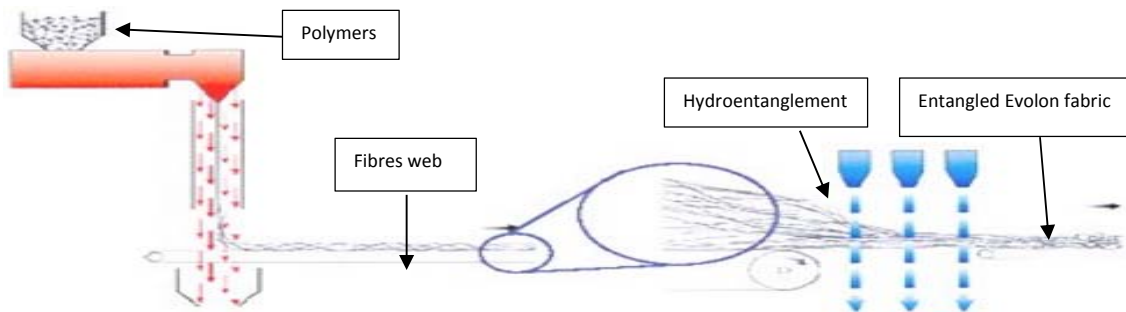
The recent advancement in technology has made it possible to develop nonwoven fabrics that are suitable for use in a wide range of apparel applications. This is due to the fact that the nonwovens fabrics produced through hydroentanglement process can now be produced that exhibit improved durability, softness, drape, texture and stretchability. Hydroentangled fabrics exhibit mechanical bonding between the fibres and that allow the fibres to freely move in the fabric structure that enhance the drapability and softness of the fabrics. Many industrial manufacturers are working on the development of nonwoven fabrics that are appealing and have apparel-like characteristics. The major companies working in this field are Freudenberg (Germany), Polymer Group Inc. (USA), and DuPont (USA). The nonwoven fabric history is very well-established but durable nonwoven fabrics for apparel purposes have repeatedly found difficulties when marketed.

University of Leeds (28) also constructed some fashion designed garments by using different nonwoven fabrics. These fabrics were supplied from different nonwoven suppliers like Freudenberg Nonwovens, Mogul, Fiberweb, Colbond, Tredegar Film Products etc. These garments are shown in Figure 2.5.



**Figure 2.5** Nonwoven garments designed by University of Leeds<sup>168</sup>

In 2000, a major milestone was the introduction of a nonwoven fabric by Freudenberg, trade named as “Evolon”. The fabric is comprised of polyester-polyamide split-able (PET/PA) island in the sea bi-component filaments, in which the splitting is induced by the high pressure hydroentanglement process. At high pressure, the filaments split into polyester and polyamide and are entangled in the form of a nonwoven fabric. Today, other polymer combinations are possible. The physical properties of this fabric are very similar to the conventional textiles in term of softness, drape and strength (29). The production process of Evolon is described in Figure 2.6.



**Figure 2.6** Manufacturing process of Evolon<sup>169</sup>

Another nonwoven fabric that was originally intended for the clothing market was tradenamed as “Miratec”. The fabric was produced by the company PGI. Miratec nonwoven is produced through the Apex technology process, which is an advanced nonwoven making process and is combined with the finishing step, by using the computer laser technology.

Miratec is a durable fabric and exhibits strength that is similar to the heavier woven fabric. Miratec also shows useful comfort, standoff and tactile properties that makes the fabric suitable for fashion garments applications (30). The nonwoven fabric has the ability to retain its structure or texture under tough working conditions (31). PGI also invented different types of nonwoven fabrics, AMIRA™ and Duralace®, which can be used as single or limited use textile materials (30).

Another commercially available nonwoven fabric produced by the DuPont is called “Nova”, which has special stretch and recovery characteristics. The fabric was produced by flash spun process and contains polyethylene fibres (32). Because of Nova’s good stretchability, many companies are using this fabric for the production of garments.

In 2003, the joint venture of Australian Wool Innovation (AWI) and Macquarie Textiles introduced a new nonwoven fabric made from wool by using the needlepunching process. The fabric was developed mainly for protective and defence clothing applications, however, its use in the furnishing applications has also been considered (34).

In the past, nonwovens were considered the supporting part of the fashion apparel in the form of interlining and insulation. However, because of the advancements in the technology, as mentioned earlier, now nonwovens can be used as outerwear. Nonwoven fabrics have now entered the fashion market because of their improved structure and aesthetical properties such as drape, hand feel and appearance. However, these fabrics do not pose any real threat to the traditional woven and knitted fabrics for apparel applications until further improvements are made and nonwoven are considered as a real alternative in the apparel market.

L. Webster (35) has studied the strengths and weaknesses of nonwoven fabrics during the garment manufacturing process and has concluded as follows:

#### Advantages

- Nonwovens have different aesthetical properties, such as look and feel.
- Have the capability to be an alternative in fashion fabrics.
- Are easy to handle during stitching.

## Disadvantages

- Do not possess enough strength.
- Fibres are tightly entangled and resist patterning.

For enhancing the tensile strength of the nonwoven, low melt bi-component PE/PET (sheath/core) fibres can be used as a binder in the main web. The low melt sheath part of the bi-component fibres will melt and allow the fibres to create thermal bonding with the neighbouring fibres and the high melt core part of the bi-component fibres will assist in maintaining the structure of the nonwoven fabric (35).

A US patent (36), describes a durable, launderable and permanent fire resistant composite fabric based garment, which meets the requirements of the military combat uniform clothing. A loosely knitted fabric is sandwiched between the two nonwoven webs in order to give dimension stability and enhance the mechanical properties of the garment. Hydroentanglement process was used to combine individual webs in shape of a composite fabric.

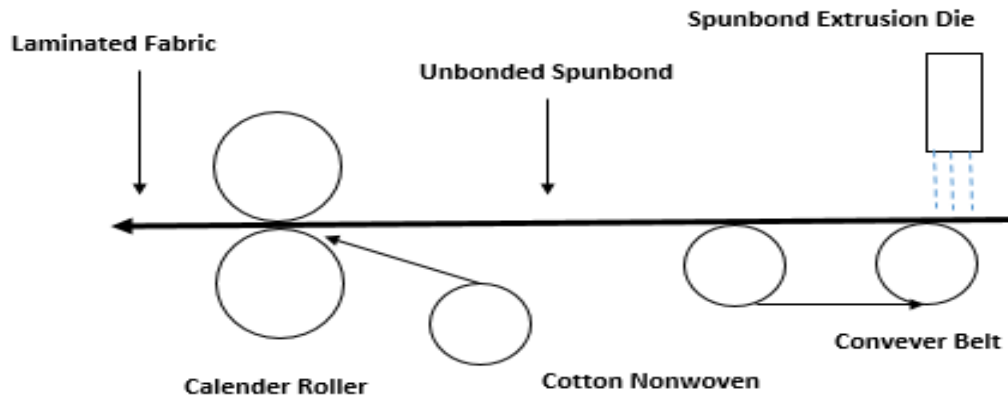
Nonwoven fabrics have entered the garment industry and are being considered as an alternative to the woven fabrics for the outer shell of garments (37). Parthasarathi and Thilagavathi (38) have described a protective nonwoven clothing that was produced by the hydroentanglement process. They produced three layers of nonwoven fabrics, the outer layer was polypropylene, middle layer was polytetrafluoroethylene (PTFE) and the inner layer was polyester. These layers were mechanically bonded through the hydroentanglement process (38). The researchers have shown that the fabric has acceptable mechanical properties, both in the machine and cross directions.

Lakeland Ltd Company also developed protective garments made by PE and PP films (39). These garments are chemical and water proof, but these garments cannot be used for long periods of time due to their poor thermophysiological comfort characteristics.

A durable protective clothing based on SMS method of bonding has been described in a US patent (40). The outer layer consists of spunlaid polyolefin based ultra-fine fibres, the middle layer is meltblown elastomeric ultra-fine fibres and the inner layer is a spunlaid porous fabric. There are some drawbacks related to this fabric, which include poor handle, stiffness and low sweat absorption. These poor characteristics

prohibit the use of the fabric in garment manufacturing for sports and fashion applications.

L. C. Wadsworth et al (41), developed a cotton laminate nonwoven fabric by cotton-spunlaid method on SB line as shown in Figure 2.7,



**Figure 2.7** Cotton lamination on spunlaying line<sup>41</sup>

Two types of fibres, cotton and polypropylene, were used in the development of the laminate nonwoven. Since the spunlaying process was used, the developed fabric had stretchability in the structure but could not capture the other aesthetical properties, such as flexural rigidity and permeability, etc. This kind of fabric can be used as a protective clothing in hospitals, but cannot be used as an outer garments, which is directly in contact with the skin.

Patterson and Backer (42) have also described that the structural characteristic - such as drape, and recovery - of nonwoven fabrics hamper their application in the apparel industry. In order to make them acceptable for garment manufacture, the following key requirements should be engineered in the hydroentangled nonwoven fabrics,

1. Durability.
2. Handability.
3. Comfortability.
4. Stitchability.
5. Appearance.

## **2.2 Performance characteristics of fabrics for clothing**

### **2.2.1 Aesthetic properties**

Fabrics for clothing applications require a number of aesthetical attributes such as drape, appearance, handle and strength. Fabric performance is the most important factor in garment manufacturing industry. Fabric performance is the result of all the parameters that are involved in the manufacture of the nonwoven fabric, including the raw materials, fabrication and the finishing processes. Performance characteristics are dependent on tensile and shearing strength, bending and surface friction (43).

The performance of a fabric as the clothing material can be divided into two categories; first is the fabric utility and second relates to the aesthetical properties of the fabric. Fabrics for garment construction should possess or fulfil a high level of comfort during wearing and this is directly related to the thermophysiological properties of the fabric (44).

The fabric should also have the capability to adopt the shape according to the body movement and this is related to the drape of the fabric. The drape is the foremost attribute of the fabric, which enhances the utilisation of the fabric in apparel applications. The drape depends on the fabric construction, for example, weaving a very compact structure will give stiffness that will affect the drape of the fabric, and in term of the nonwoven fabric, very close or highly bonded fabric structure will give a lower drape performance. Nonwoven fabric made through the hydroentanglement process can give better drape than the fabric produced through the spunlaying or chemical bonding processes (162).

Fabric comfort is not only related to its softness, but also to its thermophysiological properties. It relates to the behaviour of the fabric during perspiration process, when the human body is engaged in any physical work. During perspiration, the body releases heat and moisture and the fabric must have the capability to dissipate the metabolic heat and moisture from the body, which maintains the temperature of the body and provides the feeling of comfort (45).

Thermophysiological comfort directly relates to the moisture transport properties of the fabric. Wicking plays an important role in vapour permeation process in order to maintain the body temperature. During wicking, the moisture coming from the body (skin) is spread throughout the fabric that gives a dry feeling and comfort to the body

(46). Wicking depends on the structure of the nonwoven fabrics, the hydroentangled fabrics show the maximum capillarity. It was because of the frictional bonding between the fibres that make a large number of orifices and micro vessels for wicking. This facilitates the hydroentangled fabric to evaporate the moisture from the skin to the environment due to the effective capillary action.

The spreading of moisture throughout the fabric gives quick dryness and provides feeling of comfort to the body. On the other hand, the nonwoven fabrics produced by using the spunlaid or meltblown technology give a low moisture evaporation performance, because of their close structures. Fabrics produced through the use of these processes exhibit no spaces between the fibres and the fibres are not aligned within the fabric structure, thus resulting in a reduction of the capillary action of the fabric.

The hydroentangled nonwoven fabrics can give better thermal comfort as compared to the other types of nonwoven fabrics. Thermophysiological comfort depends on several parameters such as fabric thickness, density and porosity of the fabric (47). During the manufacturing of nonwoven fabrics for clothing purposes, these parameters must be considered for the provision of thermal comfort. The better porosity attributes associated with the hydroentangled nonwoven fabric are due to the fact that during the hydroentanglement process, the fibres are mechanically entangled and this results in a porous structure that enhances the moisture management of the fabric.

Yanilmaz et al (47) have reported that the thermal properties show a diminishing trend as the fabric thickness, tightness factor and the density of the fabric increase.

Troynikov et al (48) has reported that during the capillary action, the smaller pores are filled first and push the liquid upfront resulting in the movement of the body moisture, which spreads into the fabric. The water vapour movement is greater in the presence of smaller pores because of the higher capillary action.

For most clothing, fitting and ease of movement are very important characteristics of the garment. Garments are manufactured for different sizes and body shapes, so the fabric should have such attributes that give comfort during fitting and movements of the body.



Nonwoven fabrics, because of their resistance to shearing, bending and stiffness, do not easily accept the dimensional changes during garment manufacturing process.

### **2.2.2 Mechanical properties**

During their manufacture and use as garments, fabrics can experience different types of forces, such as tension and bending during stretching, compression and torsion. Therefore, the fabrics for clothing applications must be able to endure these forces and must have adequate level of strength. The fabric strength has a bearing on various factors such as fibre(s) type, manufacturing and finishing techniques, thickness and the density of the fabric. Backer et al (42) have reported that nonwoven fabrics must possess the ability for bending deformation and also have the ability to fit according to the contour of the body.

The fabric durability also plays an important role in the performance of the fabric. Knitted and woven fabrics show better durability during the washing process and have the capability to maintain the fabric shape after many washings. Traditionally, nonwoven fabrics do not have the ability to withstand the washing process because of loose entangling and weak bonding between the fibres caused disentangling the fabric during washing process. However, due to the advancements in the technology and materials, such as micro fibres like “island in the sea” bi-component fibres gives higher tensile strength after hydroentanglement process than a nonwoven produced by using traditional staples fibres like cotton, rayon after the hydroentanglement process. Because of the micro size fibres, there would be more fibres in per unit area of the fabric and there are also more entangling points in the fabric structure that would enhance the tensile strength of the fabric after mechanical bonding.

There are two classic examples of durable nonwovens in the market; the first one is Miratech® produced by PGI through Apex Technology and the second fabric is Evolon produced by Freudenberg Nonwoven. Evolon is produced by utilising bicomponent filament (PET/PA) island in the sea, spunlaid technology coupled with the hydroentangling process. Micro filament fibres more fibres in per unit area of the fabric that lead toward more entangling points which improved the tensile strength of the fabric and also cover . Both of these nonwoven fabrics exhibit the aesthetic and performance characteristics similar to the woven fabrics.

There is still a great deal of work to be done in the development of nonwoven fabrics for clothing applications. For example, Miratech type nonwoven fabrics are strengthened by adding some binder which makes the appearance of the fabrics unpleasant and on the other hand Evolon is spunlaid and hydroentangled nonwoven fabric, which has poor thermophysiological properties. In the case of Evolon, the poor thermophysiological performance is due to the presence of fine fibrillated island in the sea filaments, which result in a low porosity of the fabric and also the filament fibres are not aligned due to which the fabric's moisture management properties are affected adversely. Many organisations and researchers are undertaking research in order to enhance these properties and allow the nonwoven fabrics to enter the apparel market.

This literature review has been carried out in order to establish the state-of-the-art for the work carried out on the development nonwoven fabrics for garment applications. The study has attempted to review the previous work on nonwoven clothing and to analyse the current apparel woven property requirements that the nonwovens must meet to be considered as a viable alternative to the woven fabrics in apparel applications. It is obvious that there is a considerable scope for undertaking research and development work to improve the strength, aesthetic and thermophysiological properties of nonwoven fabrics by selecting the most appropriate materials, processes and the process parameters.

### **2.3 Materials selection**

The properties of nonwoven fabrics are greatly influenced by the physical properties of the fibres used in their manufacture. The main physical properties of the fibres to be considered are the physical size (length, fineness), cross-sectional shape, optical properties, melting and degradation temperatures, fluid imbibition, dimensional changes related to changes in temperature and relative humidity and the frictional properties (50). Almost all types of fibres, either synthetic or natural, can be used to make nonwoven bonded fabrics (51). The selection of the raw materials depends on the end use of the nonwoven fabric. For example, such as napkins and face cleaning, the manufacturer will prefer those fibres that can give the desirable properties, (softness, pleasant feel) such as lyocell or cotton; because the basic requirement of the nonwoven fabric in this case is to provide softness to the skin and absorbency.

The fibre's mechanical properties also influence the aesthetical properties of the hydroentangled nonwoven fabrics (52). Supposed

During the hydroentanglement process, high pressure of the water jets pushes the surface fibres into the body of the web and causes entanglement of the fibres. For this reason, the fibres should have the ability to bend easily and be able to withstand the high pressure of the water jets.

In order to obtain nonwoven fabrics with the desired characteristics, by using the hydroentanglement process, the following fabric properties need to be considered.

### 2.3.1 Flexural rigidity

The dependence of the drapability of an apparel fabric is greatly influenced by the fibre's bending rigidity (53). One of the most important factors that enhances the drapability and reduce the specific energy of the hydroentanglement process is use of the fibres that possess low flexure rigidity.

Anantharamaiah et al (120) found in their research that bicomponent fibres give flexibility and functionalization in the product and mostly sheath/core bi-component fibres are being used for this purposes.

Morton et al (54) explained in their research that flexural rigidity of the fibre can be defined as the force required to bend the fibre to unit curvature, which is the reciprocal of the radius of curvature and can be calculated by using the following relationship,

$$\text{Flexural Rigidity} = \frac{1}{4\pi} \frac{\eta ET^2}{\rho} \quad \text{Equation 1.2}$$

Where,

$\eta$  = Shape factor, dimensionless

E = Fibre specific modulus, N\*m/kg

T = Fibre linear density, kg/m

P = Fibre density, kg/m<sup>3</sup>

The factors that affect the flexural rigidity of the fibres are described in the following sections.

### **2.3.1.1 Fibre fineness**

Fibres fineness has a direct effect on the flexural rigidity of the fibres. Fine fibres give lower bending rigidity because of their smaller diameter, as less energy is required to bend the smaller diameter fibres, and on the other hand, the fibres with larger diameter require higher amount of energy to bend the fibres. The fibres with smaller diameter can entangle more easily into the body of the web than the fibres having the larger diameter (55). Therefore, researchers and manufactures tend to use fine fibres for the development and production of nonwoven fabrics that have characteristics similar to the woven fabrics.

### **2.3.1.2 Fibre length**

A blend of short and long staple fibres can result in hydroentangled nonwoven fabrics with much improved tensile characteristics. However, there is one possible drawback of using short staple fibres for making apparel type nonwoven fabrics, which is due to the rubbing action of the fabric with the skin. The rubbing action during the use of the garment can result in the pilling effect observed on the surface of the nonwoven fabric produced from the shorter staple fibres (56).

### **2.3.1.3 Fibre crimp**

The crimps in fibres facilitate processing of the fibres during the carding process and the orientation of the crimps in the fibre resists the fibre breakage during the carding action. Crimps also help in stretchability of the nonwoven fabric after entanglement process. However, high levels of crimping in the fibres may cause neps formation during the carding and can resist the movement of the fibres in the fabric region. Nep can be defined as a small knot or cluster of entangled fibres. Therefore, the higher level of crimps in the fibres, because of the lower mobility, can cause a reduction in the degree of entanglement of the fibres thus reducing the tensile strength of the resultant nonwoven fabric. Therefore, when selecting fibres for the production of nonwoven fabrics, it is important to consider the type and percentage of crimp in the fibre.

Thickness of the fabric also affects the rigidity of the fabric. Thicker fabrics resist the bending behaviour of the fabric than thinner fabric (57). Because in thicker fabric, more fibres are condensed in per unit area of the fabric and fibre cannot freely move in its region that affects the flexural rigidity of the fabric.

Bonding techniques also have an effect on the flexural rigidity of the fabric. For example, if the fabric is subjected to the thermal bonding process after hydroentanglement process and fabric is composed of 100% low melt polymer fibres then the fabric will be stiffer after the thermal process. When thermoplastic fibres heated then it turned into soft form nearly glass transition temperature and then created thermal bonding with surrounding fibres that give rigid structure. But if there is small amount of low melt polymer fibres, then it will resist the flexural rigidity of the fabric after the thermal process but not to a large extent.

Gilmore et al (58) produced a hydroentangled fabric by using foaming agents at 5% by weight. They used foamed acrylic latex binder to fully penetrate in hydroentangled fabric, in that case, it reduces the loss of desirable properties and increase the stability and abrasion resistance. They passed their fabric through two processes. In the first process, they produced a hydroentangled fabric and in the second process that applied foamed adhesive on the fabric under pressure roller. The resultant fabric showed high bending behaviour.

In the chemical finishing of nonwovens, if intensive chemicals are used then the chemical solvent fills the spaces between the fibres in the nonwoven structure. This restricts the fibre movement within the fabric structure and leads to a higher bending rigidity of the fabric.

In order to acquire desirable flexural rigidity of a nonwoven fabric, a number of parameters need to be considered, which include fibres motion, fibre diameter, fibre modulus, fabric thickness and fibre orientation distribution.

### **2.3.2 Tensile properties**

The tensile properties of nonwoven fabrics depend on the construction parameters of the web, (fibre composition and orientation, web making technique), and the type of web bonding and finishing (59). Fabric with a lower mass per unit area shows lower tensile strength and fabric with a higher mass per unit area shows higher strength. The higher tensile strength is mainly due to the higher number of fibres present in the fabric cross-section. This exerts a higher resistance during tensile loading. (60)

B. Pourdeyhimi et al (165) mentioned in their patent that the tensile and shear strength increased by adding the bi-component fibres in the fabric structure. The sheath part is

low melt than the core and during thermal bonding (hot air, infrared) when two melted bi-component fibres come in contact then they create thermal bond that lead toward higher tensile strength.

It has been observed by Desai and Balasubramanian (131), that the strength properties of thermal-bonded cotton nonwovens reduced by increasing the contents of the cotton. They have been investigated that for increasing the strength of thermal bonded cotton nonwoven fabric, the greater concentration of the binder fibres is required.

The binder fibres impart the strength at some extent then by adding more binder fibres caused reduction in the tensile strength or other aesthetical properties. It was observed by the Ghosh et al (166), that fabric tensile strength initially increased by adding 10% PE with PP blend. But strength was decreased with further increase on PE concentration, it was because of weaker strength of the PE than PP.

H. Rong et al (167), also found that addition of bi-component Eastar Bio/PP with cotton blend gave maximum tensile strength than the mono component Eastar low melt blend with cotton nonwoven fabric. Beside the binder fibres there are some other factors which effect on the tensile strength of the nonwoven fabric such as water pressure and machine variables etc.

Seyam et al (61) found that hydroentanglement energy has a significant effect on the tensile performance of the hydroentangled nonwoven fabric. With increasing the hydro pressure, the hydro energy increased and this increased the tensile properties of the fabric to some extent. Mao and Russell (62) also found that the hydroentanglement intensity affects the tensile properties of the nonwoven fabric.

Web making technique also has an effect on the tensile properties of the nonwoven fabric. Carded web in parallel way, in general, leads to a nonwoven fabric that has a higher tensile strength in MD than the air laid web method (63).

Different bonding-process techniques also have a significant impact on the tensile properties of the nonwoven fabrics. The nonwoven fabrics produced via the spunlaid and hydroentanglement processes exhibit higher tensile strength as compared with the carded web and needlepunching method (64). Pourdeyhimi et al, (65) developed a durable nonwoven fabric from staple fibres by employing a hybrid manufacturing

method. They used a combination of needlepunching, hydroentangled and thermal bonding processes. The fabric obtained exhibited impressive tensile properties that could withstand the dyeing process. The strength of a nonwoven fabric is not only dependent on the physical properties of the fibres but also on the arrangement of the fibres, such as the fibre orientation, curl and the friction between the fibres at the point of contact (66). There are a number of parameters that directly or indirectly affect the tensile properties of a nonwoven fabric. These parameters include fibre type and fabric structure, as described in the following sections.

### 2.3.2.1 Fibres

There are different aspects of fibres that affect the tensile strength of a nonwoven fabric. These include; fibre length, curl factor, fibre morphology, and fibre surface shape. The fibre length plays a pivotal role in determining the strength of a nonwoven fabric. Because during the bonding process such as hydroentanglement, the longer fibres provide a greater entanglement with the neighbouring fibres and also resist the disentanglement of the fibres in the nonwoven fabric.

Surface of the fibre also has a significant impact on the tensile properties of the fabric. For example, wool fibres carrying scales on its surface exhibit a higher tensile strength as compared to Tencel fibre. The scaly wool fibre surface provides an additional strength during entanglement of the fibre within the fabric structure because of scales as compared to the smooth surface of the Tencel fibre. The structures of wool and Tencel fibres are shown in Figure 2.8.



Wool



Tencel

**Figure 2.8** Structure of wool and Tencel fibres<sup>170</sup>

The fibre's fineness also has an effect on the tensile properties of the nonwoven fabric obtained, such as, a nonwoven fabric made from finer fibres exhibits a higher strength

than the coarse fibres. This is because, the finer fibres result in a greater number of fibres per unit area of the fabric and provide intensely entangled and stronger fabric structure.

### **2.3.2.2 Fabric structure**

Qiao, (67) has found that the mechanical properties of the hydroentangled nonwoven fabrics, such as extension at break and breaking load, are mainly influenced by the fabric structure. Sanaa, (68) tested more than thirty commercial nonwoven fabrics and found that the hydroentangled fabric exhibited relatively superior mechanical properties compared to the other nonwoven fabrics, such as thermal bonded, chemical bonded nonwoven fabric etc.

There are different parameters in the fabric structure that influence the tensile properties of the fabric. Increasing the mass per unit area of the fabric is associated with a decrease in fabric extension and increase in the fabric strength. (67) The decrease in fabric extension because of increased the area density of the fabrics. This leads to an increase in the intensity of entanglement between the fibres in the fabric, as a result, the fabric's extensibility is decreased and strength is increased both in the MD and CD. The principle behind is that the fabric is more compact due to the presence of more fibres in unit area of the fabric and there is less space for the fibre movement to occur in the fabric structure resulting in the low extensibility of the fabric.

Fabric thickness is co-related with fabric mass per unit area to some extent. But this is not a general rule. For example, the hydroentangled nonwoven fabric produced at 50 bars hydro pressure will be thicker than the fabric produced at 100 bars hydro pressure. Both fabric exhibits almost the same mass per unit area but the tensile properties of fabric produced at 100 bars will exhibit higher strength and a lower extension than the fabric produced at 50 bars. At 50 bar pressure, the fibres are not as intensely entangled as at 100 bars, therefore, the fabric will exhibit lower strength and higher extensibility. On the other hand the fabric produced at 100 bars will exhibit a lower thickness, but will show a higher strength and a lower extensibility. (69).

X. Hou et al (70) found that the different tensile behaviour of the nonwoven samples in MD and CD is because of the pattern of the bond point and fibre orientation in the region of the fabrics. There are different types of bonding techniques used in the nonwoven fabric manufacturing, depending on the end-use of the fabric.



Thermal bonding of nonwoven webs occurs in three steps (1) heating the fibre in the web, (2) bonding the fibres, and (3) cooling the bonded web (71). According to G. S. Bhat, et al (72), the surface temperature of the rollers plays a vital role in obtaining better tensile properties. The elongation and strength increase with bonding temperature and then decrease after an optimal value. The workers further found that the initial increase in the mechanical properties is due to good fibre-to-fibre bonding, however, excessive heat can cause over-bonding and alter the material's structure. Excessive bonding temperature can also result in voids in fabric region and this may lead to the loss of molecular orientation, slower crystalline kinetics and also decrease in crystallinity. The formation of voids at the bonding point can affect the tensile properties of the nonwoven fabric. (73)

Mechanical bonding is achieved by inter-fibre friction, as a result of the physical entanglement of the fibres. Stitch bonding, needlepunching and hydroentangling are different processes by which the fibrous webs are physically entangled through inter-fibre friction. Web consolidation in the needling nonwoven fabric is achieved through higher needle density and needle penetration. However, there is a limit beyond a point the fabric will deteriorate with increasing the machine variables (needle penetration, no. of strokes, etc.) (74). When barbed needles are pushed and pulled through the web, they produce mechanical bonds within the web.

Hydroentangling is the process of mechanically bonding and intertwining of the neighbouring fibres due to high velocity water jets, which produce water agitation in the web. Fibre entangling depends on the transfer of kinetic energy from the water jets to the web to create mechanical bonding. Because of the high water pressure, the fibres are entangled with their neighbouring fibres because due to the fibre friction and strengthen the fabric.

Chemical bonding is based on setting bonds between the fibres by adding adhesive binder substances to the web by using techniques, such as saturation, foaming, printing and powder techniques (75). The purpose of chemical bonding is to achieve fibre-to-fibre bonding and to enhance the nonwoven characteristics such as strength, softness, adhesion, durability, recovery, etc.

Gilmore et al (76), produced hydroentangled fabric by using foaming agent at very low level (less than 5% by weight) of incorporation. They allowed the foamed acrylic latex

binder to fully penetrate in the hydroentangled fabric in such a manner as to reduce the loss of desirable properties and increase the stability and abrasion resistance. The resultant fabric showed good abrasion resistance with a minor effect on the aesthetic properties, such as comfort and drape.

Hydro pressure and intensity of the water pressure also has an impact on the tensile properties of the hydroentangled fabric. Mao and Russell (62) found in their studies that the intensity of water pressure influence the entangling behaviour of the fibres and they developed a model to predict the fibres bonding intensity before the hydro process.

$$y = \frac{\sqrt{2}\pi g \rho_w^{0.5} \rho_f n C_d D^2 p^{0.5} d_x^4}{12 E d_f^2 m v_b} \left( 1 + \sqrt{1 + \frac{48 E d_f^2 m v_b^2 K_2}{\pi^2 g^2 \rho_w \rho_f n^2 C_d^2 D^4 d_x^4 p}} \right) \dots\dots\dots (1)$$

Where,

$\rho_w$  is the density of water (1000 kgm<sup>-3</sup>)

$\rho_f$  is the fibre density (kgm<sup>-3</sup>)

n number of jets per unit length in a water jet strip (ends/m)

$C_d$  water flow discharge coefficient (0.66)

D diameter of the orifice (m)

m area density of the web (kgm<sup>-2</sup>)

$d_f$  fibre diameter (m)

y deflection depth of fibre (m)

$v_b$  belt speed (m/s)

p hydrostatic pressure drop per jet (Nm<sup>-2</sup>)

$d_x$  diameter of a water jet stream on the surface of the web (m)

E young's modulus of the fibre ( $\text{Nm}^{-2}$ )

$K_2$  is kinetic energy of water jets

Equation 1, is showing that by using fine fibres the fibres deflection would be high and that can enhance the tensile properties by intense bonding. It is also showing that fibre's young's modulus also impact on the mechanical properties of the hydroentangled fabrics.

### **2.3.3 Air permeability**

The pore structure of the fabric has a direct effect on its air permeability. The air permeability increases as the pore size increases, which depends on different parameters, such as fibre fineness, bonding techniques and finishing processes (77).

Fabric mass per unit area and consolidation of the fabric also have a major effect on the air permeability of nonwovens as the mass per unit area is increased there are more fibres present and resulting in less space between the fibres for air circulation. (78) The fibre cross-section also has an effect on the air permeability of the resultant fabric. Hollow polyester needlepunched nonwoven fabric shows the lowest value of air permeability followed by the regular and trilobal cross-sectional fibre based nonwoven fabrics (79).

Air permeability decreases with the increase in fabric mass. Increase in fabric mass leads to the fabrics that are thicker and denser, resulting in a consolidated fabric structure (80). Though the amount of pores is increased with the increase in number of fibres, the pore size becomes smaller, which in turn lowers the air permeability of the fabric. Tascan, et al (81) found that the air permeability of a nonwoven fabric also depends on the total surface area of the fabric. The woven fabric produced from the solid polyester hollow fibres exhibited lower air permeability because of its greater thickness, lower porosity and closer structure. On the other hand, woven fabric produced from the trilobal polyester fibres exhibited higher air permeability (82).

### **2.3.4 Thermophysiological properties**

Thermophysiological properties of a fabric depend on its air permeability and water vapour permeability properties (83). The air and water permeability properties are greatly influenced by the fibre type, fabric structure, porosity and finishing processes

(84). There are different types of instruments that have been used to measure the thermal resistance of fabrics but the most common techniques are Alambeta and Hot Plate methods (84).

It was pointed out by Kawabata and Yoneda in their research that warm-cool feeling by the body relate to the thermal absorption of the fabric and an instrument to measure the thermophysiological comfort parameters was developed by Lubos Hes (85). Frydrych, et al (85) also found in his research that thermal resistance also depends on the fabric thickness – thicker fabric gives higher thermal resistance. This observation was supported by the work of Alay et al. (86), they also found that the thermal resistance depended upon the fabric thickness, thermal resistance increases with an increase in fabric thickness.

The thermal comfort of clothing is directly linked with the thermal balance of the human body. (87) The fabric should be capable to transmit the perspiration from the body to the environment in order to cool the body (88). The moisture transfer and quick dry behaviour depends on the capillary capability and moisture absorbency of the fibres (89). Drying is an important factor of fabric in terms of comfort. The time required for drying depends on the moisture affinity and the water holding capacity of the fibres (90).

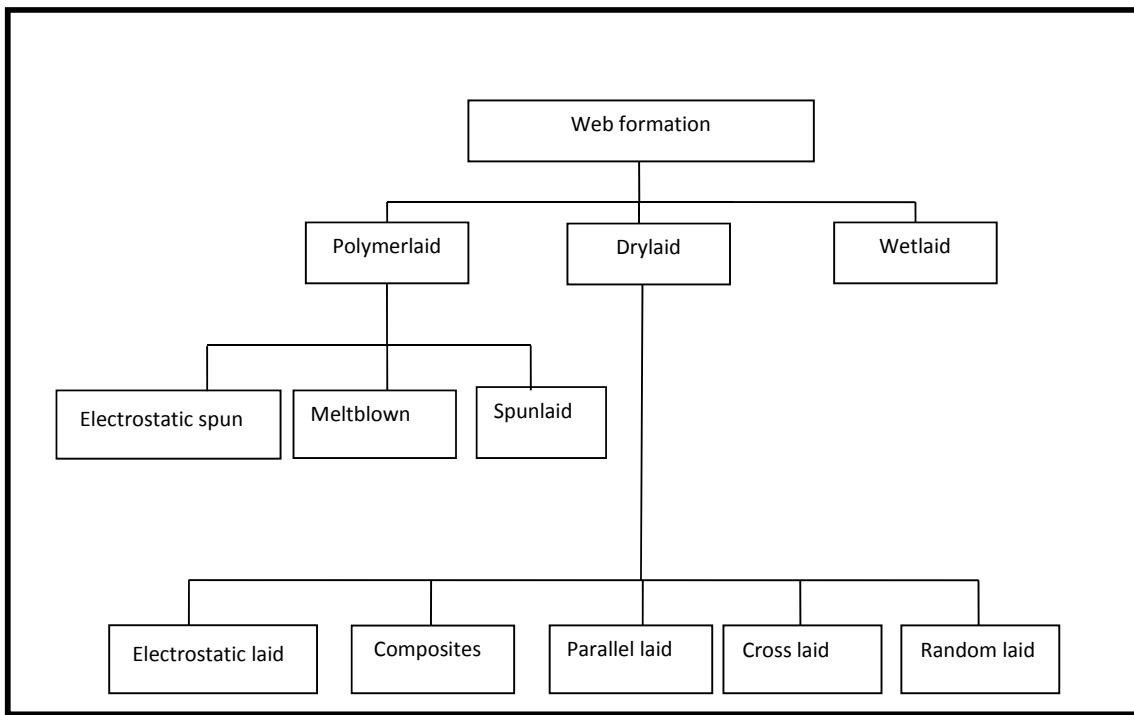
Moisture absorption behaviour and structural properties of a nonwoven fabric are interdependent. Structural properties, such as fibre arrangement (fibre orientation, pore structure, etc.) and fibre features (morphology) are quite important in determining the moisture absorption behaviour of the fabric. The liquid diffusion in nonwoven structure is due to the presence of spaces between the fibres in the form of capillaries (91). Special fibres have been introduced to enhance the wicking and liquid transport by creating additional capillary channels such as micro fibres.

Xiao Chen et al (92) found that the addition of finer fibre in a blend improved the absorption ability of the coarser fibres. The finer fibres create the smaller capillary pores within the fabric, and because of this, there is strong wicking of the liquid due to the higher capillary pressure. Fangueiro et al (89) demonstrated that the wicking process starts only in wet fabrics or when fabrics come into contact with water then contact angles determine the wicking behaviour of the fabric. A lower contact angle results in high wicking behaviour. Saricam and Kalaoglu (90) reported that water

evaporation rate is inversely proportional to the fabric thickness, as the thickness increases the air space between the fibres decreases, which causes less water to evaporate.

## 2.4 Web formation

In the nonwoven process, the fabrics are made directly from the fibres. The fibres are bonded through different methods such as chemical bonding, thermal bonding and mechanical bonding. Normally, for the mechanical bonding method, a manageable fibrous web of calculated parameters is required (93). There are three main types of webs used in the production of nonwoven fabrics: wet-laid, dry-land and polymer-laid. The types of the web formation is described in figure 2.9.

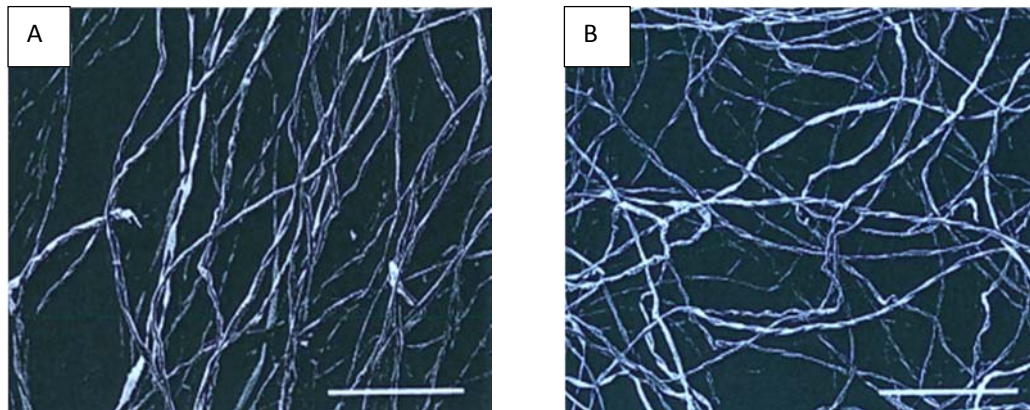


**Figure 2.9** Types of web produced for nonwoven fabrics<sup>171</sup>

To some extent the properties of the nonwoven fabric - such as tensile strength, absorbency and drape depend on the alignment of the fibres in the web. The web making technique affects the fabric properties and the cost, therefore it is important to select the appropriate web making process so that nonwoven fabric is produced cost-effectively and has the desired characteristics for the proposed end-use application. Carded web gives higher individualisation and parallelisation in the fibrous web, but

the web produce through the air-laid web technique gives random fibre structures in the fibrous web (93).

In the carding process the fibres are controlled by the nips of the rollers, which starts from the taker-in to the doffer. This means that the fibres are processed through physical control and are not allowed to disperse into different directions, thus guiding the fibres into higher parallelisation than the air-laid process. In air-laid process, the fibres are moved through pneumatically, which leads to the random structure of the resultant nonwoven as shown in Figure 2.10B.

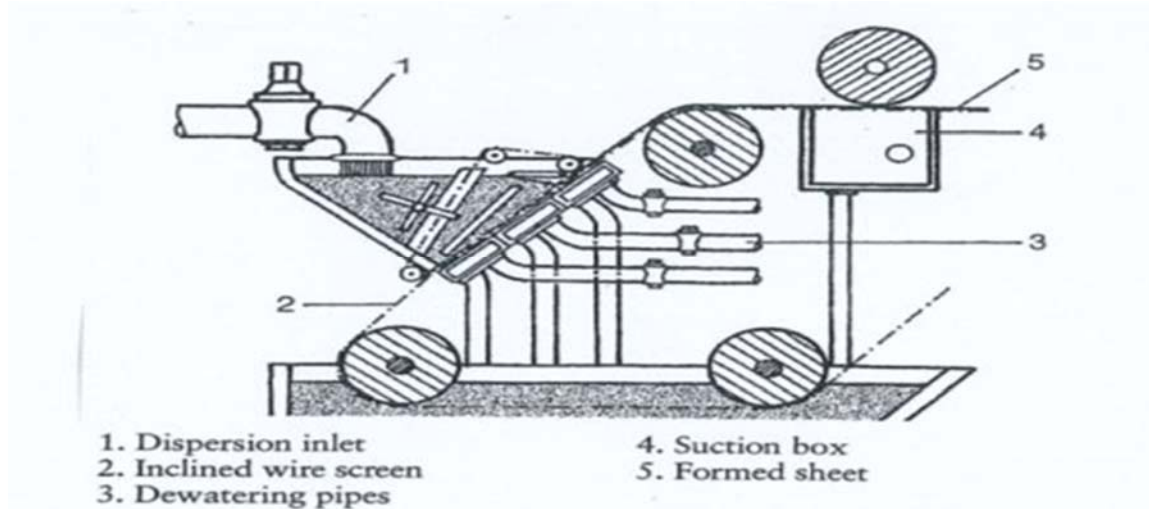


**Figure 2.10** SEM images of carded (A) and Air-laid (B) webs<sup>63</sup>. (The scale bars for images A and B are 200 and 500  $\mu\text{m}$ )

The uniformity of the web is an important parameter, because if the web is not uniform the resultant nonwoven fabric will have thick and thin places, which will affect both the appearance and tensile properties of the fabric. The three main methods used for making webs for nonwoven fabrics are briefly described in the following sections.

#### **2.4.1 Wet-laid web**

According to INDA, “wet-laid web is produced by filtering an aqueous suspension of the fibres onto a screen conveyor belt or perforated drum” (94). The wet-laid web making process is illustrated in Figure 2.11.



**Figure 2.11** Wet-laid web making process<sup>172</sup>

During dispersion of the fibres, two main factors should be considered. These are the long staple fibres and short staple fibres. The long staple fibres could get into knots and the short fibres can disperse easily but have a low tendency to entangle (95). The web mass can vary from 10 g/m<sup>2</sup> up to 1000 g/m<sup>2</sup> but the mass below 30 g/m<sup>2</sup> is not effective, because of the fewer fibres per unit area of the fabric (96).

### **2.4.2 Dry-laid web**

The definition of a dry-laid process according to INDA is, “a process for forming a web from fibres by using dry laying process” (94). The main purpose of the carding step is to separate the single fibres from small tufts and give them a shape into a web form. The carding process also results in cleaning and straightening of the fibres thus the resultant nonwoven fabric has better aesthetical and mechanical properties (93). As mentioned above, a card basically opens up the randomly tufted fibres and unidirectionally individualises and parallelises them in the machine direction by means of the combing action of the wired card clothing. A nonwoven card does not have the resolving flats as on the cotton card, but it has either set of fixed rollers (Figure 2.12) or has fixed metallic plates, which are set very close to the main cylinder wire clothing for processing the fibres. It has been reported that the web obtained from the roller top nonwoven card shows well- individualised and parallelised fibres in the web structure and on the other hand the web obtained from the air-laid process shows random pattern of the fibres (93). The nonwoven fabric made from the carded web exhibits a

higher tensile strength in the machine direction than the fabric made by using the air-laid web (93).

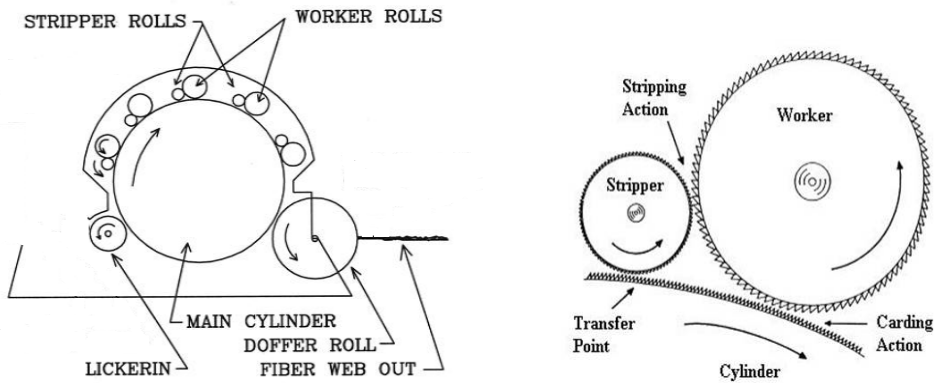


Figure 2.12 Dry-laid Carding Process<sup>63</sup>

### 2.4.3 Air-laid web

Air laying is also a type of dry-laying process. In air laying, the fibres are fed into an air stream and from there to a perforated drum that gives an oriented web. Mostly short fibres are used for air-laying process. The air-laid webs normally have a lower density, a greater softness and an absence of laminar structure as compared to the carded webs and they are more versatile in terms of the types of fibres and fibre blends that can be used. The air-laid process is illustrated in Figure 2.13

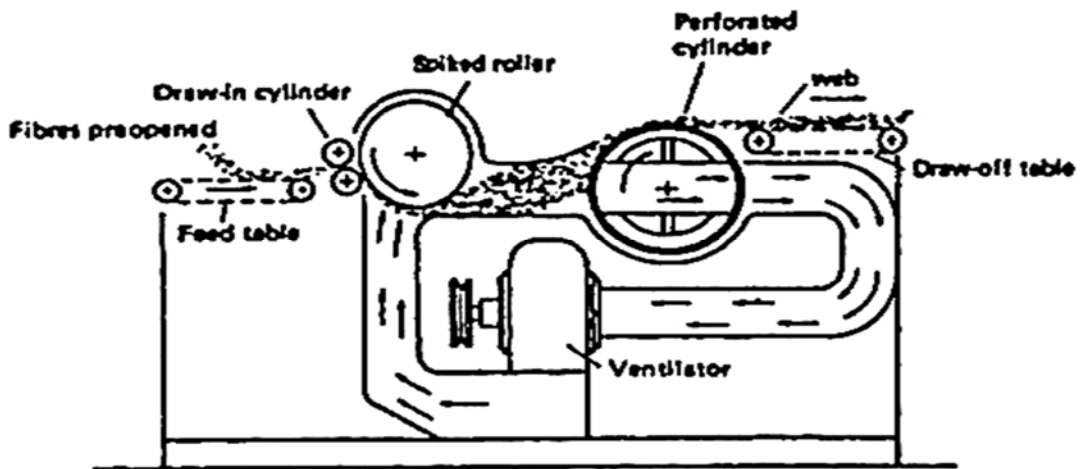
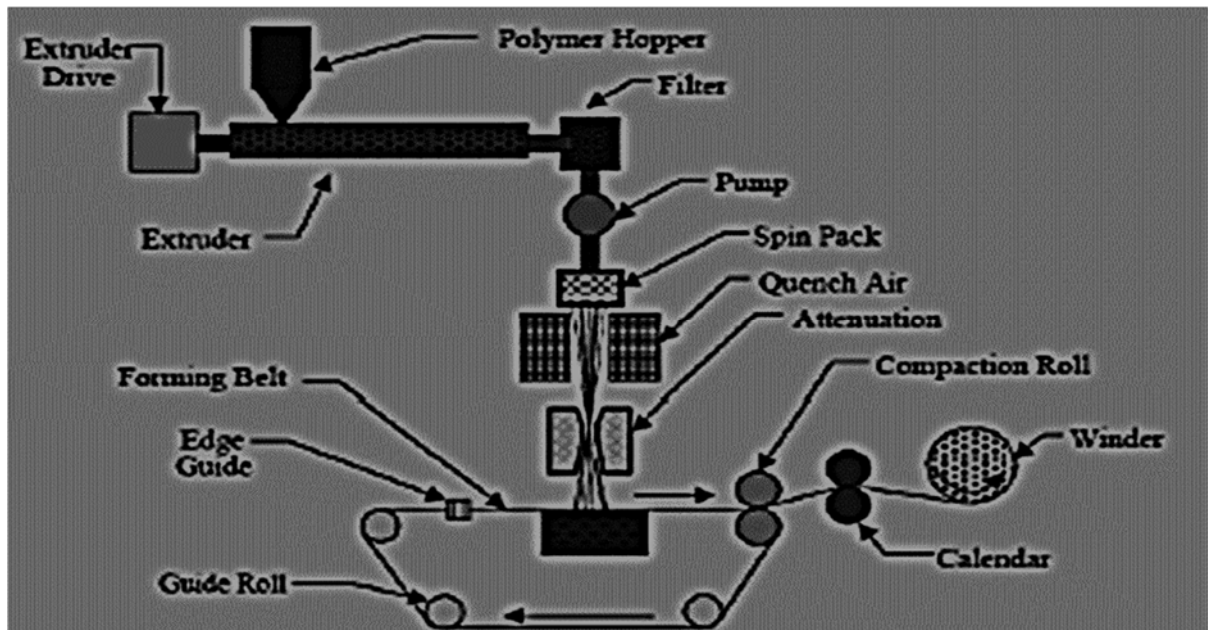


Figure 2.13 Air-laid nonwoven Process<sup>171</sup>



#### 2.4.4 Spun-laid web

The spun-laid process is also called the spun-bonded process. This process results in nonwoven fabrics with greater strength, however, raw material flexibility is much limited as compared to the other web formation processes. Co-extrusion of polymers is also possible and is used in several spun-laid processes in order to obtain nonwoven fabrics with special characteristics and additional bonding capabilities.



**Figure 2.14** Schematic diagram of the spun-laid process<sup>173</sup>

#### 2.5. Pre-needling process

In order to obtain a coherent web for the hydroentanglement process, light needling or pre-needling can be carried out on the web in order to stabilise the structure. The needling process is shown in Figure 2.15.

Pre-needling improves the basic mass of the fabric because this process intact web structure that do not allow the fibres to disperse during hydro process, due to which the mass per unit area increased as compared with no-needling process. After the carding process, the fibres are loosely packed with relatively a few contact points between fibres and thus fibres can freely move in the web. Pre-needling gives some initial strength to the web in the form of entanglements of the fibres for achieving the

desire properties of the resultant fabric (97). Some of the factors that influence the properties of the nonwoven fabrics during the needling process are listed below (98),

### Raw materials

- Fibre type
- Length,
- Fineness,
- Crimp

### Web characteristics

- Fibre orientation
- Web uniformity
- Web thickness

### Machine parameters

- Needling density
- Type of needles
- Needle arrangement in the needle board
- Needle penetration

Narayanan et al (99), have developed a durable hydroentangled nonwoven fabric by using the needling process. These researchers have demonstrated that the pre-needling step enhances the mechanical strength of the resultant hydroentangled nonwoven fabric.

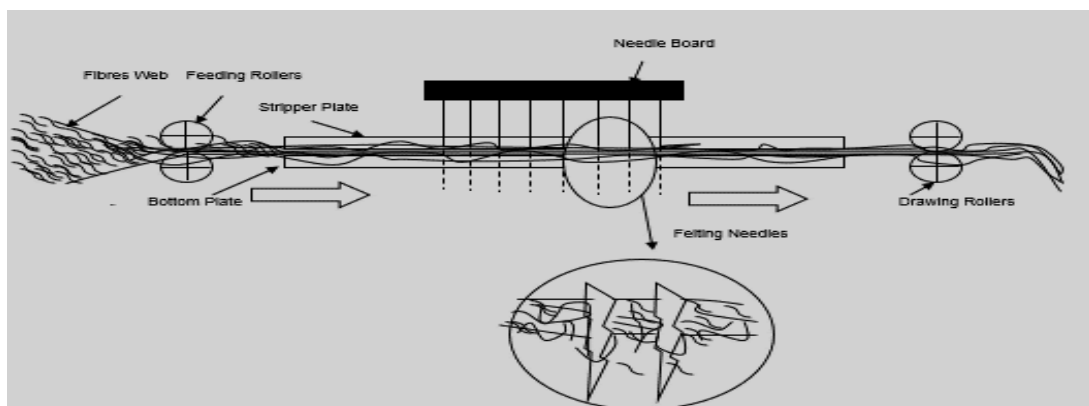


Figure 2.15 Illustration of pre-needling process<sup>132</sup>

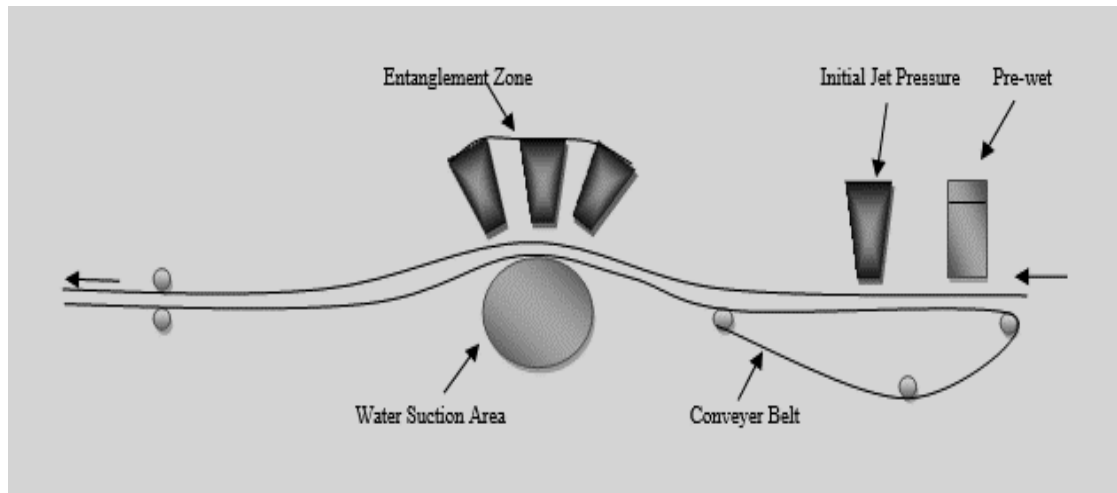
The pre-needling process does not result in any physical damage to the fibres because of the lightness of web, which provides no frictional resistance to the movement of the fibres (98). The basic purpose of the pre-needling process is to tuck the loose fibres within the web for the next process. The tucking-in of the fibres enhances the aesthetical properties of the resultant hydroentangled fabric by maintaining an even weight throughout the web. It has been reported that light needling consolidates the web for easy processing during the hydroentanglement process (100).

## **2.6 Hydroentanglement process**

### **2.6.1 Introduction**

Hydroentanglement is a mechanical process, which is employed in order to interlock the fibres in a web structure, by the use of fine and highly pressurised water jets. This results in nonwoven fabrics with good texture and appearance. High pressure of the water jets pushes the fibres from the top of the web into the interior of the web structure, which forms wires and results in the rearrangement and intermingling of the fibres (101). It is basically an energy transfer process that forces the fibres to interlock and give strength to the resultant fabric (101). The hydroentanglement process is schematically illustrated in Figure 2.16

As mentioned earlier, hydroentanglement is an energy intensive process and therefore a significant part of the nonwoven production cost is related to the energy consumed during the hydroentanglement process. The cost can be minimised by the use of appropriate web structures and fibres properties. The main steps in the manufacture hydroentanglement fabrics are: web formation; web bonding; fabric drying; and finishing.



**Figure 2.16** Hydroentanglement process<sup>111</sup>

During the hydroentanglement process, the web first passes through the pre-wetting area, where the web is condensed and the air trapped between the fibres is eliminated. After pre-wetting, the web is passed through the entanglement zone, where fibres are entangled under high pressure of the water jets. The resultant hydroentangled nonwoven fabric is then transferred to the dryer. Figure 2.16 shows that in the entanglement zone a perforated suction drum is positioned under the high pressure zone for drawing the water from the consolidated web. Since the hydroentanglement process is an energy transfer process, it is therefore important to determine the amount of energy involved in the production of a nonwoven fabric. According to Pourmohammadi et al (102), the total energy applied in the process can be calculated by using the following equation:

$$E \text{ (MJ/Kg)} = 1.11C_d \frac{1}{W_S} \sum_{i=1}^N n_i d_i^2 p_i^{3/2}$$

Where,

E = energy/mass of web

$p_i$  = Water pressure (bar)

$C_d$  = Co-efficient of discharge

$d_i$  = Diameter of jet orifices (m)

W = Web area density (kg/m<sup>2</sup>)

$n_i$  = Number of jet orifices/metre

S = Delivery speed (m/s)

The major research effort towards the development of durable nonwoven fabrics is focussed on the hydroentanglement process. The main reason for this is the considerable improvement in the physical properties, such as softness, flexibility, drape and strength, of the nonwoven fabrics that can be obtained by using the hydroentanglement process. This is considered to be the most suitable process for the production of durable nonwoven fabrics (61). Hydroentangled fabrics with these properties are widely used in technical applications including medical textiles (wound dressings, gowns etc.) household items such as wipes, napkins and textiles such as interlining. The aesthetical properties of the hydroentangled nonwoven fabric depend on the fibre properties and the hydroentanglement process parameters (93).

In the hydroentanglement process, the main entity that affects the properties of the fabric is the amount of specific energy of water that is applied to the fibrous web. The fabric strength and softness are greatly influenced by the applied specific energy. The specific energy mainly depends on the following three factors (61).

1. Pressure.
2. Time under the pressure.
3. No. of passes.

Hydroentanglement process can be used to produce nonwoven fabrics with area density in the range of 20 to 500 g.m<sup>-2</sup>. The hydroentanglement process has eliminated the need of using chemical or thermal binding in the nonwoven industry to a great extent (93). Nearly all kinds of textile fibres can be used in this process. The flexibility and compressibility of the hydroentangled fabric make it easier to mould into different shapes. It is due to these characteristics of the hydroentangled nonwoven fabrics that they are highly recommended for the sports apparel applications.

The hydroentanglement process is a fast process and therefore the fabric production rate is high and the conversion costs are relatively low as compared to the conventional fabric production processes. This is mainly due to the fact that the entire yarn making process is eliminated and the staple fibres can be directly converted into fabrics. The isotropic structure, tensile and bending properties of the hydroentangled fabrics depend very much on the physical properties of the fibres used and the manufacturing process parameters employed (103). Fibre's loops play an important role in the entanglement or binding of the fibres within the structure of the nonwoven

fabrics produced. The behaviour of fibre depends on the fibres bending rigidity and the water jet pressure of the hydroentanglement process. An increase in the number of loops is obtained as the water pressure is increased. Therefore, the water jet pressure and fibre's flexural rigidity play important roles in the loop formation (103). The structural changes, such as the web thickness, formation of entanglement, fibre deformation, reorientation and displacement consume a great deal of the applied energy. The fibres having a lower flexural rigidity will consume lower amount of energy to bend than the fibres having higher bending rigidity values. It has been shown that at the lower hydro pressure, fibres in the core part of the web are less entangled and at higher hydro pressure more effective entanglement of the fibres is observed (103).

Ghassemieh, et al (104) have demonstrated that the physical properties of the web and fibres are the major factors in determining the amount of energy needed for a desirable degree of entanglement. These researchers have also reported that insufficient energy transfer can only rearrange the fibres without making entangling bonds. Therefore, in order to obtain high quality hydroentangled fabric, provision of sufficient amount of energy is essential, which also has dependence on the properties of the fibres and the web.

The mechanical properties of the hydroentangled fabrics are in general anisotropic. The orientation of the fibres in the web determines the direction in which the fabric strength is the greatest. In the parallel laid webs, the dominant fibre orientation is in the MD, therefore the hydroentangled fabrics produced by parallel laid webs will exhibit higher strength in the MD and on the other hand, the fabrics produced by using the cross-laid web will exhibit a higher strength in the CD. Ghassemieh, et al (104) have also found that the effectiveness of entangling effect by the water jets is higher in the machine direction. In general, the strength ratio in the machine direction to the cross direction is much larger for the fabrics produced from parallel laid webs than the cross-laid webs.

Thickness of the fibre web has a significant effect on the mechanical properties of the resultant hydroentangled nonwoven fabric. P. Xiang et al (105) found that the fabric strength depends on the fibre web properties (mass, thickness etc.). Fibre web with the lowest thickness has the largest degree of fibre entanglement during the hydro process. It was also found that for fibre web having large thickness, the kinetic energy

of the hydro water only affected the upper portion of the fibre web and caused no entanglement of fibres in its lower portion.

### **2.6.2 Background of hydroentanglement process**

Historically, the entangled fibre concept originated from Chicopee's patent, entitled 'plural pattern technology', which was published in 1953 (106). In this process, a fibrous web was placed on a belt and then the fibres were rearranged by hydraulic forces according to the belt pattern. The hydroentanglement process was commercially introduced by DuPont in 1973 and is a result of considerable work done by DuPont and Chicopee. DuPont obtained five patents on hydroentangled nonwovens during 1963-1970. In this process, the fibres were entangled by using water jets. The fibres were interlocked, bent, and twisted around the surrounding fibres in a web structure (106). The fabric strength is entirely dependent upon the entanglement of the fibres and the frictional forces between the fibres within the structure of the fabric (55). The major drawback of the hydroentangled fabric is its poor recovery from deformation and the fabric has different properties in the machine and cross directions (106). It mostly depends on the web structure like fibres orientation, fibres type and also on the intensity of the bonding after hydroentanglement process.

However, the nonwoven fabrics produced by using this process exhibit much higher tensile strength than the needlepunched fabrics (59) depends on the fibres properties and bonding structures.

Since the 1990's, the hydroentanglement technology has been made more efficient and affordable and this has led to a considerable growth in the production and utilisation of the spunlaced nonwoven fabrics. There are now diverse applications of hydroentangled fabrics, such as in home furnishing, bedding, industrial fabrics, garments and protective clothing (50). The essential requirements for these applications are dependent on the raw material characteristics and process parameters. The tensile properties of the hydroentangled fabrics are determined by the structural parameters and fibre properties (50).

### **2.6.3 Parameters affecting properties of hydroentangled fabrics**

The intensity of entanglements depends on the properties of the fibres used and the machine related process parameters. The water pressure is one of the main process parameters that have a considerable influence on the mechanical properties of the produced hydroentangled nonwoven fabrics. It has been reported that an increase in the water pressure resulted in an increase in the bursting strength, tensile strength and flexural rigidity of the lightweight hydroentangled fabrics (69). Moyo and Patnaik studied the interaction between the fabric area density, water pressure and belt speed. The researchers found that the tensile properties of the nonwoven fabrics increased with an increase in the water pressure; however, when the belt speed was increased a reduction in the tensile strength of the nonwoven fabric was observed (107). It was also found that the tensile strength increased up to an optimum value of water pressure and any further increase in the water pressure resulted in a reduction of the tensile strength of the fabric, due the damage caused to the fibrous structure by the excessive force of the water pressure (107).

The mechanical properties of the nonwoven fabrics depend on the structural arrangements of the fibres within the fabric construction, such as fibre orientation, fibre curling and thickness. These changes impact on the mechanical behaviour of the fabric. Backer and Petterson (108) also found that the tensile strength of the nonwoven fabric depends on the fibre orientation, fibre's tensile properties and the bonding between the fibres.

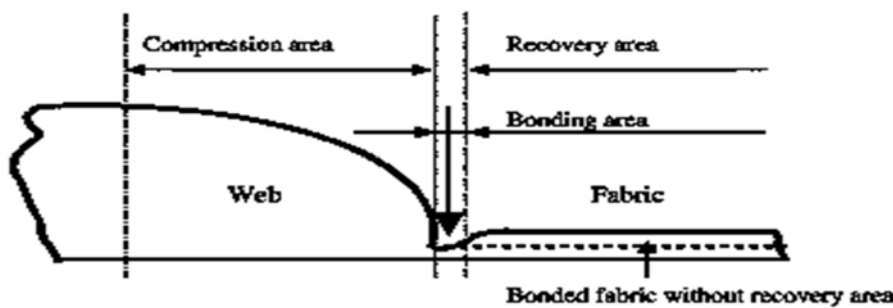
Ghassemieh et al (104) found that the maximum strength in fabric is first achieved at a certain critical water pressure. Any increase of pressure above the critical value does not increase the fabric strength. The researchers also found that higher water pressure was required in order to obtain the maximum strength in PET nonwoven fabric than the fabric made from viscose fibres, which required a lower water pressure to obtain the maximum strength fabric. This is mainly due to the differences in the modulus values of the corresponding fibres used. The wet modulus of the viscose fibre is lower than the PET fibre, therefore, lower energy is required for getting better entanglement for viscose based hydroentangled nonwoven fabrics, which results in higher strength values at lower water pressures.



Fibre orientation predicts the direction of maximum strength of the nonwoven fabric, such as parallel laid web gives the maximum strength in the machine direction and the cross-laid web gives maximum strength in the cross direction. Entanglement of the different sides of the web also plays an important role in gaining maximum strength at lower pressures. If one side of the web is passed through the entanglement zone, the fabric will exhibit a lower tensile strength value as compared to the fabric, which has both sides passed through the entanglement zone of the hydroentanglement process (104).

Mao and Russell (103) have reported that the water energy is first absorbed to compress the bulky web, then at the second stage bending of the fibres takes place and then at the third stage the fibres are entangled. They also found that water jet pressure induced energy is consumed by different structural and geometrical changes in the web: (a) initial compression of the web; (b) fibre entangling and fibre bending and orientation. This is illustrated in Figure 2.17.

Fibres deformation depends on the fibre density, fibre diameter and the modulus and it was found that the lower fibre's rigidities require lower specific energy for effective entanglement. The water energy is also consumed by the water standing in the web and to overcome the frictional forces between the fibres in the compressed web (103).



**Figure 2.17** Fibres compression and bonding behaviour under water pressure<sup>111</sup>

Ghassemieh et al (104) also reported that the properties of the fibres, such as fibre length, inter-fibre frictional force, bending modulus, are the factors that determine how much energy is required for the production of the required hydroentangled nonwoven fabrics. These workers have also described the microstructural changes that occur

during the hydroentanglement process, which are fibre orientation and rearrangement of the fibres after the hydro process and the change in the fibre length through the curling and the migration of the fibres into the inner side of the fibrous web. These microstructural changes assist to estimate the fibre's contact points and the friction between the fibres within the structure of the fabric.

Consecutive processing of the fabric (increasing the number of passes or sides under the hydro pressure), increases the entanglement points but at a diminishing rate because of the resistance of the fibre movement in the fabric structure (66).

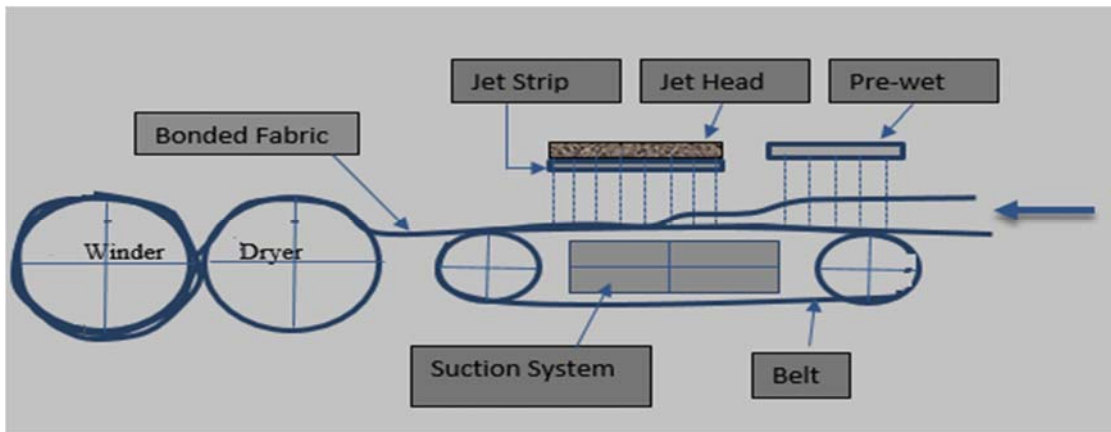
Porosity and air permeability are important parameters for the nonwoven fabrics in term of their applications in apparel clothing. It has been discussed earlier that the air permeability mainly depends on the fabric area density, thickness, fibre diameter and the density of the fabric (77).

O.B. Berkalp, (77) has found that an increase in the water pressure results in a decrease in the air permeability due to the decrease in the porosity and increase in the density of the hydroentangled nonwoven fabric. The wicking and absorption properties of nonwoven fabrics also depend on the structural properties of the fibres and the nonwoven fabrics. Ramachandran, et al (109) found that the hydroentangled nonwoven fabrics exhibit high wicking and absorption behaviour than the other types of nonwovens.

Mao and Russell (62) found that the process-structure property relationship analysis assists in achieving the desirable hydroentangled nonwoven fabrics with satisfactory performance. These researchers have found that fibres having a low wet modulus give better entangling intensity as compared to the higher wet modulus fibres and have developed two hydroentangled nonwoven fabrics made by using 1.7 dtex viscose rayon and polypropylene fibres. The tensile strength of these fabrics, both in the machine and cross directions, was measured as a function of the applied energy. It was observed that at the lower hydro pressures, the viscose based nonwovens exhibited higher tensile strength as compared to the polypropylene fibre based fabric. However, the polypropylene fibre based fabric exhibited higher tensile strength but at the higher pressure or energy levels during the hydroentanglement process. It was concluded that the fabric tensile strength had a positive correlation with the intensity of the hydroentanglement process.

### 2.6.4 Supporting media

The surface of the conveyer is an important factor that affects the fabric strength, fabric structure and the energy consumed (60). The conveyer belt should be permeable and normally woven mesh of metal is used. The permeability of the structure of the conveyer and the engravings help in dewatering the web and impart some pattern to the fabric, respectively, during the hydroentanglement process. Mesh pores also play very important role in determining the fabric strength. The mesh with smaller open area gives higher strength to the fabric than the mesh with larger open area of the pores. The fibrous web is held onto the surface of the belt with the help of suction (Figure 2.18), which is applied beneath the belt. The suction also assists in the removal of the water from the belt and leads to the consolidation of the web (61).



**Figure 2.18** Hydroentanglement process supporting media<sup>63</sup>

Nonwoven fabrics are bonded with the help of the high water jet pressure from the injectors that are located above the carded web. The injectors push the water onto the web surface with high pressure and because of the hard belt surface, the water rebounds from the belt surface creating very effective entanglement between the fibres. The rebounding action depends very much on the physical properties of the supporting media (belt) (66). In order to attain high level of entanglement, the action of water rebound must be optimised.

### 2.6.5 Injector action

The injectors are very critical components of the hydroentanglement process. Injectors are made of steel and have the capability to withstand high water pressures up to 1000 bar during the hydro process. The number of injectors and the pressure used depend on the nonwoven fabric composition and the web density and normally 5 to 8 injectors are used in the hydroentanglement process. The injector consists of a cylindrical feed chamber with attached filtration system. The high pressure water is delivered toward the jet strip nozzles through the distribution region (66). The nozzles are mostly 90-150  $\mu\text{m}$  in diameter and the water velocity passing through these nozzles is about 350 m/s (63).

### 2.6.6 Dryer

The nonwoven fabric is dried after the hydroentanglement process by using suction or by using hot air dryers. The method used is dependent upon the nature of the fibres used in the production of the nonwoven fabric. Synthetic fibres are easily dried by the employing suction of the machine; however, the hydrophilic fibres, such as cellulosic, are dried by the application of hot air or by using the drum drying process.

During the development of fabrics, the essential criteria for hydroentangled fabrics published elsewhere were taken into consideration. The required properties are linked with the technical requirements of the fabric and further linked with the process and materials properties as mentioned below:

### 2.7 Selection of processes for developing nonwoven clothing for apparel applications.

<b>Functionality</b>	<b>Properties</b>
1. Ability to move according to body movement	Flexural Rigidity
2. Washable	Tensile properties
3. Comfort to the body	Thermal properties
4. Dryness during sweating	Absorption and Wicking
5. Soft to skin	Surface characteristics

### **Fabric properties**

1. Flexural Rigidity
2. Tensile Property
3. Thermophysiological Property
4. Absorption and wicking Property
5. Surface Characteristics
- 6.

### **Fabric Structural properties**

- Fibres movement in the fabric structure, fibre structure
- Bonding intensity between the fibres
- Fabric structure, fibre's structure
- Fabric structure and fibre's properties
- Fabric appearance and fibre's physical properties

## **2.7.1 Nonwoven manufacturing methods**

### **Bonding Method**

1. Mechanical Bonding
2. Chemical Bonding
3. Thermal Bonding

### **Processes**

- Needle Punching, Hydroentangle
- Foaming, Solvent
- Hot air, Infrared rays, Calendering

On the basis of the above discussion, two innovative processes are developed and for acquiring the require properties in the developed fabrics, more advanced and innovative fibres are selected. These processes and materials are discussed in chapter 3.

## **2.8 Summary**

From the literature review, it can be concluded that there are myriad of nonwoven fabrics available but mostly they are used in area of hygiene and protective clothing. There are some limitations in the developed nonwoven fabrics so that they cannot be used as single fabric for garment manufacturing. The history of developing garments from nonwoven fabric is very old. It commenced in the 1960s when first paper clothing was introduced into the market by an American company but due to some limitations, the product was removed from the clothing market. Since then many companies and researchers have developed a number fabrics for apparel applications. These include Kimberly-Clark, who invented "Demique" through the melt-blowing of thermoplastic micro fibres. This fabric is mostly used in the diapers and hygiene products rather than for garment manufacturing purposes. In the late 19s, Freudenberg also invented a nonwoven fabric for lining but not for the outer shell or garment manufacturing.

In the late nineteen century, Kimberly-Clark developed a composite nonwoven fabric based on SMS technique and this fabric was also not suitable for the garment

manufacturing purposes because of its inferior thermophysiological comfort properties. In 2003, Kuraray Company produced a nonwoven composite fabric based on a three-layer fabric for protective clothing. This fabric was again not suitable for the casual clothing purposes because of its limitations in the thermophysiological properties. This fabric was also composed of three layers, which were bonded by the thermal bonding process that had a very detrimental effect on the water vapour and air permeability of the fabric.

USA military based research company (RDA), conducting research on nonwoven clothing for military uniforms, has developed a strong nonwoven composite fabric for military uniform, which is found to be satisfactory in terms of its properties for military uniforms. This is a special fabric and it is specifically made for the military purposes, because of its three-layer composition.

Freudenberg invented an innovative nonwoven fabric with the name of “Evolon” fabric through the spin-laying and hydroentanglement technologies from bi-component fibres. It is highly suitable for garment manufacturing and possesses many properties that are required in the outerwear clothing.

It is clear from the literature review that most of the current nonwoven fabrics are suitable for the protective or hygienic applications. Very few commercially available nonwoven fabrics can be used for the garment manufacturing purposes, because of the limitations in their performance properties, such as high flexural rigidity and inferior thermophysiological characteristics. Therefore, the main focus of this research is on the enhancement of the functionality of the nonwoven fabrics for the apparel applications. Mechanical bonding processes are more favourable for producing the nonwoven fabric because of its aesthetical properties. In mechanical processes, needle punch and hydroentanglement processes are the key processes by which the require properties can be achieved in nonwoven fabrics for apparel applications. So, the emphasis is on the selection of innovative materials and establishing improved manufacturing process, which could lead to the production of nonwoven fabrics that are suitable for apparel applications.

## CHAPTER 3

### Materials and Experimental Methods

#### 3.1 Raw materials

##### 3.1.1 Introduction

The selection of the raw material used in the development of the apparel nonwoven fabric is very critical process due to the fact that the resultant nonwoven fabrics properties predominantly depend upon the raw materials and production processes employed. The raw materials determine the nonwoven fabric properties in terms of hand feel (softness), absorbency and flexure rigidity etc. The absorption properties depend on the composition of the fibres (110). For example, in order to obtain better absorbency in the fabrics, hydrophilic fibres are used. Smaller dtex or denier gives more fibres per unit area that contribute to the tensile properties of the nonwoven fabric. The flexure rigidity of the fibres gives an extra edge in consumption of the energy during the hydroentanglement process. Fibres having lower flexural rigidity will use less energy to deform into loop form than the harder fibres. (111)

The physical structure of fibres also has an impact on the esthetical properties of the nonwoven fabric, for example, the round shape fibres will give better lustre and gentle touch to the skin. On the basis of the wearer comfort properties, very innovative fibres were used in the development of the nonwoven apparel fabric. Two main fibres used in this study were Tencel and bi-component sheath/core (PE/PET) fibres. Tencel fibres are the main component of the fabric development because of fibrillated structure and the smooth surface. Bi-component fibres are used because of enhancing the tensile properties of the resultant fabrics after thermal process.

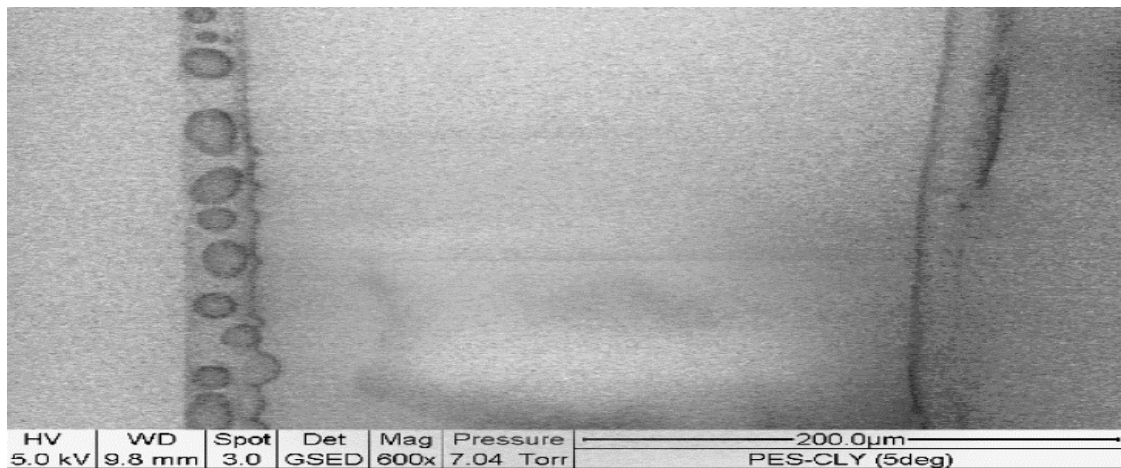
##### 3.1.2 Tencel®

Tencel is a regenerated cellulosic fibre derived from wood pulp and has all the functional properties that a wearer desires in the fabric that include moisture absorbency, comfort, lustre, durability and excellent colouration characteristics. It gives high strength in dry and wet conditions because of its higher molecular orientation in the fibres (112). Tencel fibres are more absorbent and softer than cotton and silk. (113).

Tensile strength of Tencel fibre is higher than cotton and can be comparable with normal polyester fibre. The fibre has high strength in the wet state, which makes it ideal for use in hydroentanglement technology for making apparel type nonwoven fabrics. Because of its high modulus, Tencel has minimum shrinkage in water, which makes the nonwoven apparel fabric made from this fibre launderable (114). The unique properties of Tencel fibre are described in the following sections.

### 3.1.2.1 Moisture management

Because of its unique fibril structure, Tencel fibres provide micro channels for transportation of the moisture from the body to the environment, which helps to keep the body temperature at the required level and enhances the wearer comfortability. Because of the absorbent property, there is a limited chance of bacteria growth in the fabrics that are made from Tencel fibres (113). Tencel is hydrophilic in nature, which makes it water absorbing and breathable. Water is absorbed into the fibre structure. The absorbency property of Tencel and polyester fibre is illustrated in the Figure 3.1.



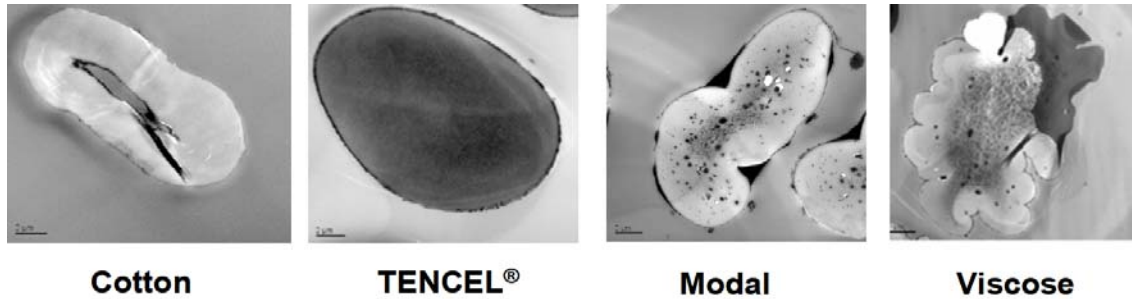
**Figure 3.1** The SEM of Polyester (PET) (left) and Tencel® fibres (right) in water vapour atmosphere<sup>115</sup>

Figure 3.1 shows that polyester fibre has water droplets on its surface and on the other hand Tencel® fibre does not show water on its surface. This means that the polyester fibres are non-absorbing fibres as compared to the Tencel fibres (115). This property of Tencel fibre enhances the physiological properties of the resultant nonwoven hydroentangled fabrics.

The water distribution of Tencel is very uniform as compared with other cellulosic fibres because of its unique fibril structure that contains numerous hydrophilic and crystalline



nano-fibrils that assist in water absorption. Because of this, Tencel based fabric gives excellent wear comfort and also exhibits good water management behaviour within the structure of the fabric. Figure 3.2 shows the cross-sections of different cellulosic fibres and it is demonstrated that Tencel fibre has better water absorbing system than other cellulosic fibres because of its unique nano-structure (115).



**Figure 3.2** Transmission electronic micrographs of cellulose fibres showing the water absorbing capacity<sup>115</sup>

Because of the unique absorption system of Tencel fibre, it helps to maintain the body temperature during physical activity of the wearer. Energy is transferred in the form of latent heat of vaporisation that is carried by the sweating of the body. Sweat carries the heat from the body and evaporates it into the surrounding environment through the fabric.

### 3.1.2.2 Softness

The rough surface of the fibres causes skin irritation and discomfort to the wearer. The fabrics made from Tencel fibres have smooth surfaces and provide gentle feeling to the skin and the wearer can feel better comfort as compared to the fabrics made from cotton and wool fibres (Figure 3.3). Furthermore, Tencel fibre exhibits round cross-section that enhances the lustre of the resultant fabric.



**Figure 3.3** Comparison of surface appearance of Tencel, Wool and Cotton fibres<sup>113</sup>

### 3.1.2.3 Tensile Characteristics

Tencel fibre has very high tensile strength in wet and dry states as shown in Table 3.1

**Table 3.1** Tensile properties of Tencel fibres and comparison with other fibres<sup>182</sup>

Property	Unit	Tencel	Viscose	Cotton	Polyester (PET)
Linear density	dtex	1.7	1.7	1.18	1.7
Dry Tenacity	(cN/tex)	38-42	22-26	20-24	50-55
Dry Extensability	%	14-16	20-25	7-9	25-30
Wet Tenacity	(cN/tex)	34-38	10-15	26-30	50-55
Wet Extensability	%	16-18	25-30	12-14	25-30
Modulus	(cN/tex)	731.3	-	525.5	698.9

Table 3.1 shows that Tencel fibre has much higher dry strength as compared to the other cellulosic fibres and this higher strength enhances the aggregate strength of the resultant nonwoven fabric (116). The table also shows that the wet tenacity of Tencel fibre is lower from its dry tenacity but still higher than cotton and viscose fibres. This leads to the better entangling of fibres during the hydro process, without breaking any fibres, and as a result, the strength of the nonwoven fabric made from Tencel is higher as compared to the cotton and viscose based nonwovens.

### 3.1.3 Bi-component sheath/core (PE/PET) fibre

In this study, the bicomponent fibres sheath/core (PE/PET) were used as the binder fibres for imparting extra tensile strength to the nonwoven fabrics via the thermal bonding process. Bicomponent fibres are very innovative multifunctional fibres. These fibres are manufactured from processing of two different polymers through the same spinneret, consisting of core and sheath configuration. The sheath is made of a low melting polymer (polyethylene) and the core material is made of polyester. Since the sheath melts at a lower temperature than the core, therefore, it can be used as a binder material in the nonwoven fabric. On the other hand, the core material has higher melting point so it is not melted during the thermal bonding and it ensures the integrity of the nonwoven fabric. (117)

N. Anantharamaiah et al (120), found in their research that Evolon made by the bi-component 16 segmented pie PET/PA spunbond and mechanical bonding process and it was observed that this fabric showed poor tearing strength because of no mobility of the fibres in the fabric structure. But, in this study, the bi-component sheath/core PE/PAT was used to give more strength (without affecting other aesthetical properties of the fabric) during thermal bonding after hydroentanglement process. It was induced by Andreassen et al (163) that nonwoven fabric's tensile strength mainly depends on the intensity of the bonding point rather than the fibres properties. So, by adding the sheath/core low melt bicomponent fibre will give extra bonding point during thermal bonding that will lead to the incremental tensile strength on the fabric.

Kim et al (164), found that difference in melting point of two different polymer is favourable for thermal bonded nonwoven fabrics because one polymer component melt and create thermal bonds and other polymer component maintain the shape of the nonwoven fabrics. He also pointed out that thermal bonded through hot air give soft effect to the fabric. Results demonstrated that the bi-component fibres used in this study (PE/PET) have low and high melting point for enhancing the strength without affecting the structure of the fabric.

The two fibres were chosen because of their innovative structures and good specifications that can result in the production of durable nonwoven fabrics for apparel applications. The specifications of the fibres are given in Table 3.2

**Table 3.2.** Specifications of Tencel and Bi-component fibres<sup>170, 183</sup>

Property	Tencel	Bi-component, PE/PET, (sheath/core)
Sources	Lenzing, Austria	Fibre Visions, Denmark
Length mm	38	40
Linear density dtex	1.4	2.2
Tenacity cN/dtex	3.6	2.5-3.6
Breaking Elongation %	14	100-160

Table 3.2 shows that both of the fibres have similar technical properties with the exception of breaking elongation, which is much higher for the bicomponent fibre. The bicomponent fibres play a pivotal role in the strengthening of the nonwoven fabric through the thermal bonding process.

### **3.2 Processing methods**

There were two basic steps in the development of hydroentangled fabrics. The first step was the formation of the carded web and the second step was the bonding of the web into a durable nonwoven fabric through the needlepunching and hydroentanglement processes.

#### **3.2.1 Web preparation**

Before making the web, the raw materials were mixed according to the defined different blend ratios such as 100% Tencel, 80%/20%, 70%/30%, 60%/40% and 50%/50% Tencel/bi-component fibres. The both fibres were pre opened manually and mixed according to the blend ratio. The opened fibres were then processed through the card on the pilot nonwoven line.

The pilot card machine consisted of a manual feeding system, a take-in roller that takes the material from the feeding belt and passes it to the breast unit. The breast unit is comprised of one main swift with four workers, a striper and a doffer. The maximum width of the card is 0.5 metre. In this study, web width was kept at 0.5 metre and length was kept at 1.0 metre, parallel-laid webs were produced. The card was used to produce nonwoven fabric with area density in the range of 120 and 150 g/m<sup>2</sup>.

Two types of nonwoven fabric samples were produced:

Hydroentangled with pre-needling process

Hydroentangled with needling process

#### **3.2.2 Needle punching and pre-needling**

The carded parallel-laid webs were needle punched on one side. The purpose of needle punching is to pre-entangle the fibres in the web for getting better strength and also to enhance the coherence of the webs that minimises the dispersion of the fibres during the hydro process. During the hydro process, there are chances of dispersion of the fibres in the web as the high intensity of water pressure hits the web. This will affect the tensile properties of the resultant nonwoven fabric. Needle punching step also reduces the bulkiness of the web and facilitates the web to pass under the water jets without being any disturbance. V. K. Midha et al (98), also reported in their paper that by needling process the web gets condensed that increased the density of the fabric.

Ventura et al (181), found in their research that, needling parameters also impact on the mechanical properties of the nonwoven fabric such needling density, needle

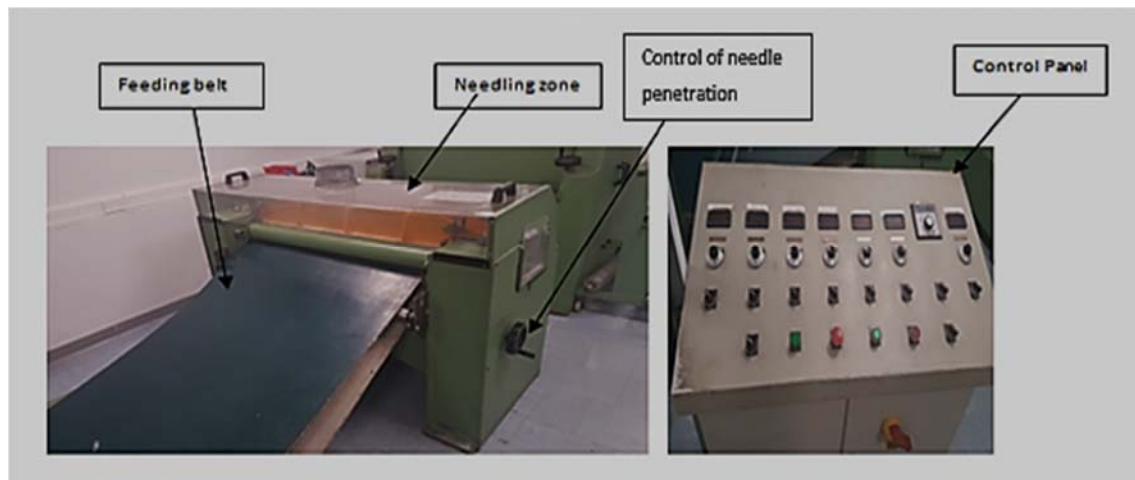
penetration depth, needle type and geometry. More energetic process resulted in compact structure of the nonwoven fabric that leads toward better mechanical properties. So, during needling process, the parameters of the needling machine should be according to the required properties of the hydroentangled nonwoven fabrics. It means, the web should not be too condense that effect on the aesthetical properties of the resultant fabrics, on the other hand, the pre-needled web should not be too lose that effects on the mechanical properties of the resultant fabric after hydroentangled fabrics.

Pre-needling will also facilitate the hydroentangle process, there will be less energy would be used in bending the fibres because many fibres are already in entanglement conditions and higher entanglement can be obtained at lower energy level of hydroentanglement process.

Rawal et al (182) also reported that process parameters such as feed rate, stroke speed and needling depth effects on the pore structure of the nonwoven fabrics, higher the stroke frequency and needle penetration leads to ward reduced the pore size because of damaged of the fibres.

Lower the pore size caused the air permeability values lower, which affects the comfortability of the resultant fabrics.

On the other hand, the purpose of pre-needling step is to tuck the web that reduces the bulkiness of the carded web and also to reduce the amount of air trapped in the web structure. The pilot needling machine used in this study is shown in Figure 3.4.



**Figure 3.4** Pilot needling machine for producing needlepunched nonwoven fabrics<sup>174</sup>

The specifications of the needlepunching processes are given below in Table 3.3

**Table 3.3** Specifications for needling and pre-needling processes

(A) Needlepunching

<b>Parameters</b>	<b>Specifications</b>
Feeding Speed Setting	1m/min
Needle Penetration	8 mm
Strokes	100/min
Delivery Speed Setting	1.2 m/min
Needle Density	23/cm width
Needle length	3.5 inch
Needle type	Conical

(B) Pre-needling

<b>Parameters</b>	<b>Specifications</b>
Feeding Speed Setting	0.65 m/min
Needle Penetration	2 mm
Strokes	60/min
Delivery Speed Setting	1 m/min
Needle Density	23/cm width
Needle length	3.5 inch
Needle type	Conical

3.2.2.1 Precautions during needling process

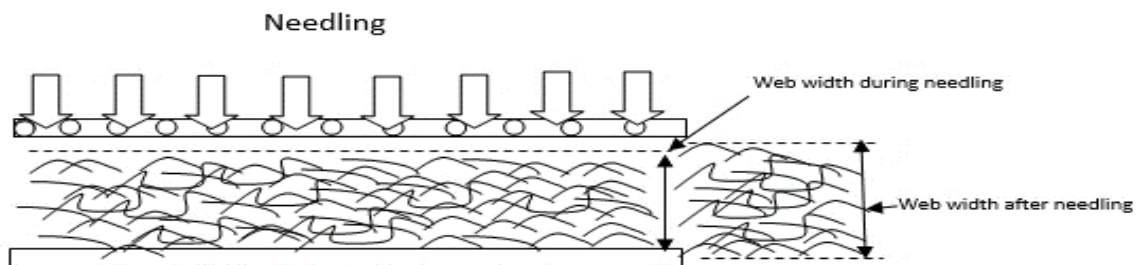
During the needling process, feeding and delivery speeds play important roles, which can directly affect the resultant nonwoven fabric in terms of the fabric area density and the tensile properties. Therefore, it is important that there must be a balance between the feeding and delivery speeds of the machine. If the delivery speed of the needling machine is higher than the feeding speed then it will result in the drafting process, which will reduce the area density of the fabric. However, if the delivery speed is equal

to the feeding speed then thick lines will appear in the resultant nonwoven fabric. This is because when the needles hit the carded web, the web stops for a while and since the delivery speed is same as the feeding speed it will not pull the web as the web is coming to the machine. Therefore, the web will be stuck in the machine for a short while, which will cause the thick line in the resultant nonwoven fabric.

### 3.2.2.2 Drawbacks of pre-needling

One drawback of the pre-needling process was observed after the hydroentanglement process. Needle marks were observed in the resultant hydroentangled nonwoven fabrics. In this project, the needle penetration was 8mm and strokes were 100 per minute, if punches are reduced to 40 per minute from 100 per minute and needle penetration reduced to 6mm, then the needle marks can be controlled at the acceptable level.

Secondly, it was also observed that the needling process reduced the number of fibres per unit area. Because during the intensive needling, the fibres were dispersed into different directions, which increased the web width after the needling process as shown in Figure 3.5. Before entering the needling process, the web width was 0.5 m and after the needling the web width was increased to 0.65 m (i.e. an increase of 0.15m in width) and resulted in a reduction of the number of fibres per unit area of the fabric.

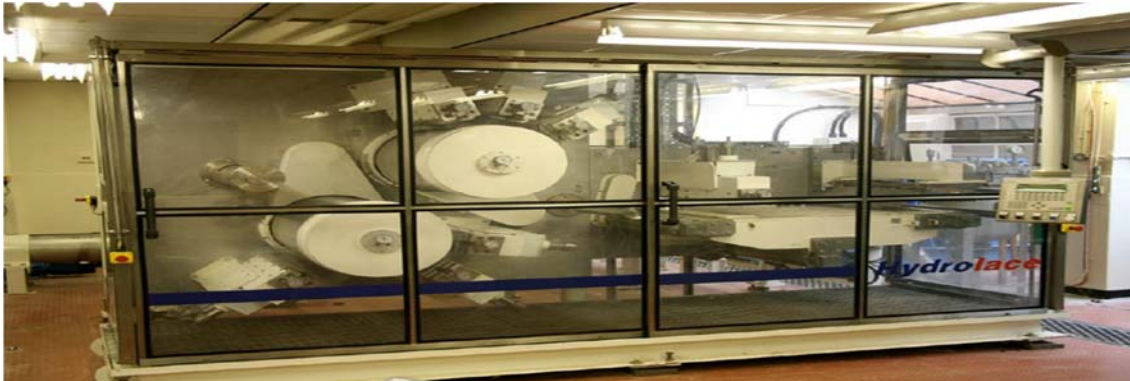


**Figure 3.5** Dispersion of fibres during needling process<sup>74</sup>

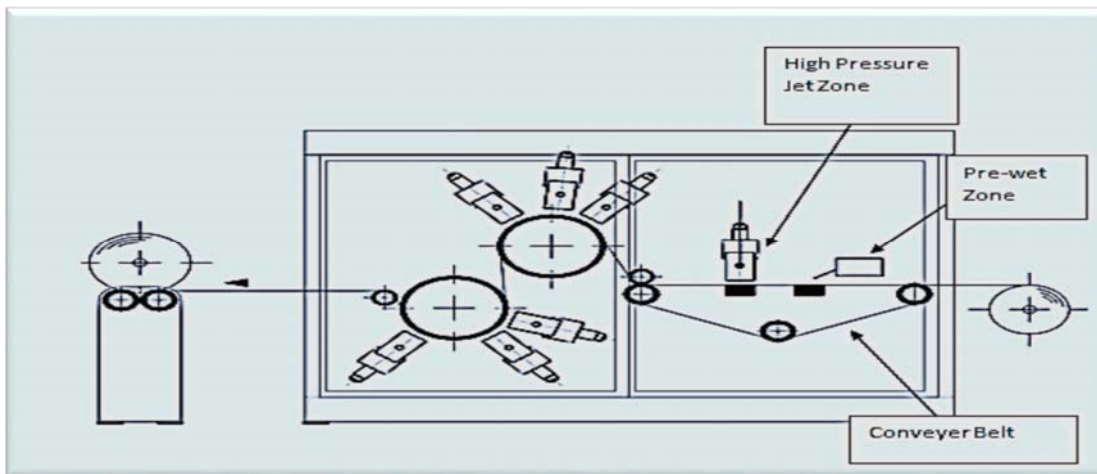
### 3.2.3 Hydroentanglement process

The Hydroentanglement is a method for manufacturing of nonwoven fabrics by means of high intensity of water pressure. This high intensity of water pressure entangles the fibres into a nonwoven fabric (118). Hydroentanglement is arguably the fastest growing bonding technique in the nonwoven field. It is an transfer method, in which energy is transferred to the web through high water pressure. The hydroentanglement

machine used in this study was 0.5 metre wide and was capable of operating at maximum of 250 bar pressure. The machine is illustrated in Figures 3.6 and 3.6a.



**Figure 3.6** Pilot hydroentanglement machine for producing hydroentangled nonwoven fabric<sup>175</sup>



**Figure 3.6a.** Schematic view of pilot hydroentanglement machine<sup>175</sup>

There are four main sections of the hydroentanglement machine:

1. Fabric manufacturing section: consists of pre-wet area, belt for web support and the water pressure injectors.
2. Supporting area: consists of water tank, water filters and high pressure water pump.
3. Suction system: consists of suction pump and the water supply to the tank.
4. The control panels

The carded web was placed on the conveyer belt of hydroentanglement machine in the machine direction (MD). In the first part of the hydro process the web was condensed by pre- wetting in order to consolidate the fibres before moving to the high pressure zone of the hydro process. This is important because, if the carded web is



passed under the high pressure water jets without pre wetting then there is a chance that the fibres can disperse, which will affect the quality of the resultant nonwoven fabric.

In the high pressure zone, high intensity of water pressure comes over the fibres through jet orifices that forces the fibres to entangle with their neighbouring fibres. Furthermore, when the water pressure jets hit the conveyer belt then part of the water pressure rebounds upwards in different directions resulting in further enhancement of the fibre entanglement. The bicomponent fibres were crimped fibres, which also helped to entangle the fibres tightly, thus increasing the tensile properties of the resultant fabric. Due to the crimps present in the bicomponent fibres, the fibres find it difficult to disentangle the web easily, which helps to maintain the integrity of the nonwoven fabric against the external forces during the working conditions (56).

The both sides of the fabric samples were passed through the hydroentanglement machine in order to obtain more coherent bonding in the fabric structure. After the hydro process, the samples were passed through the dryer at 80°C for 10 min. During the drying process, it was ensured that the temperature did not exceed 80°C, since the samples consist of 30% bicomponent sheath/core PE/PET fibres and “PE” part has low melting point, therefore, the fabric can distort at temperature higher than 80°C. The specifications of the hydroentanglement process are given below in Table 3.4.

**Table 3.4** Hydroentanglement machine specifications

<b>Parameter</b>	<b>Specification</b>
Belt speed	5m/min
Jet orifice diameter	120µm
Jet density	556/m
Pitch	0.9mm
Pressure	50,75,100,125 and 150 bars

### 3.2.3.1 Calculations of specific energy

During the hydro process, known amount of water pressure pushes the fibres into the web for making fibre wires, which leads to the development of a durable nonwoven fabric. This is basically an energy transfer process that entangles the fibres in the form of durable nonwoven fabric, which gives desirable results in term of tensile and aesthetic properties (119). The specific energy is an important factor, which influences the fabric properties and can be calculated based on Bernoulli equation, which ignores the viscous losses. (120)

The specific energy was calculated in three steps. Firstly, the jet velocity ( $V_1$ ) was calculated by using equation 1, then at the second, step rate of energy transferred by water jet was calculated by using equation 2. Finally, the specific energy was calculated by using equation 3. The details of the three equations are gives below:

#### Equation 1

$$V_1 = \sqrt{2P_1/\rho}$$

Where,

$V_1$  = Jet Velocity (m/sec)

$P_1$  = Pressure in Pa (1bar =  $10^5$  Pa)

$\rho$  = Density of water 998.2 kg/m<sup>3</sup>

#### Equation 2

Rate of energy transferred by water jet is calculated by,

$$E = \pi/8 \rho d^2 C_d V^3$$

Where,

$d$  = Diameter of orifice in metre

$\rho$  = Density of Water (kg/m<sup>3</sup>)

$C_d$  = Coefficient of discharge

$V$  = Jet Velocity (m/sec)

E = Energy Rate (J/s)

### Equation 3

Specific Energy calculated by,

$$SE = E/M \text{ (J/kg}_{\text{fabric}} \text{)}$$

Where,

E= Energy rate (J/sec)

M = mass flow rate of the fabric in kg/sec

“M” is calculated by using following equation,

$$M = \text{sample width (m)} * \text{Basic weight (kg/m}^2\text{)} * \text{Belt Speed (m/sec)}$$

#### 3.2.4 Experimental procedure

Samples of the web with area density of about 120 g/m<sup>2</sup> were cut in dimensions of 0.5m x 0.5m, as per machine requirements. At the first stage, five base samples with different blend ratios were prepared at 125 bars hydro pressure for getting the best samples that exhibit higher mechanical and aesthetical properties for further investigation.

At second stage the best blend ratio base samples were investigated by producing different samples at different hydro pressures of 50, 75, 100 and 125 bars.

The consumed energy at different pressures is given in Table 3.5. The following two basic parameters were used in the hydroentanglement process:

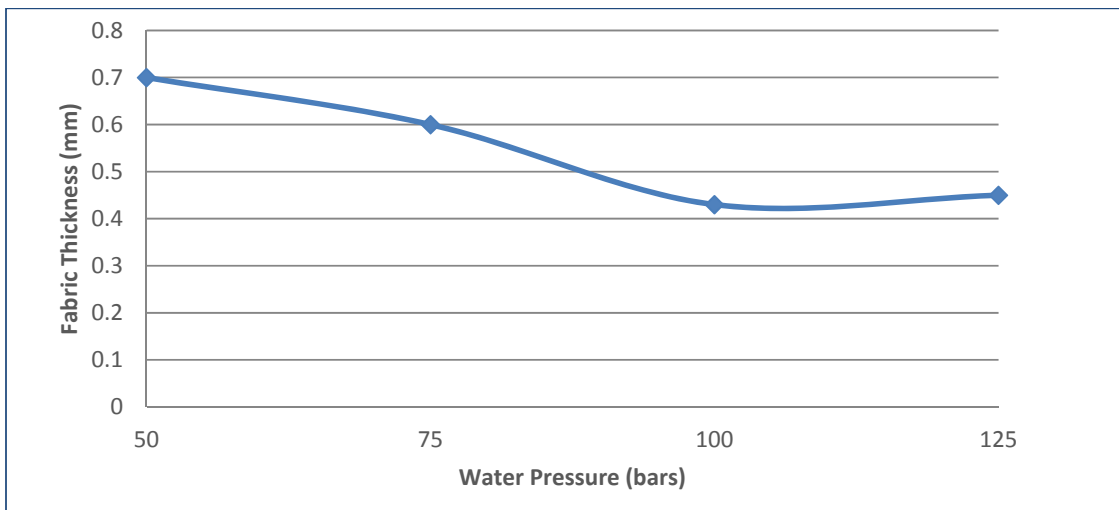
Web area density = 117 g/m<sup>2</sup>

Number of passes = Two

**Table 3.5** Calculated specific energy based on different water pressures during hydroentanglement.

Pressure (bars)	Weight (g/m <sup>2</sup> )	Thickness (mm) 5g/cm <sup>2</sup>	Energy (J/kg)
50	117	0.70	284
75	114	0.26	958
100	118	0.27	2274
125	116	0.22	4440

On the basis of Table 3.5, it can be concluded that with the increase in water pressure the specific energy was increased, which had a direct effect on the tensile strength of the fabric. As the pressure increased the thickness of the fabric was reduced. Since the increase in pressure (from 50 bar to 100 bar) leads to the exertion of higher force on the fibres, which resulted in the enhancement of the fibre entanglement within the fabric structure. Therefore, the number of fibres per unit area of the fabric were increased and the thickness of the fabric was reduced, as shown in Figure 3.7. It is evident from the figure that the thickness of the fabric was decreased as the water pressure was increased.



**Figure 3.7** Effect of water pressure on fabric thickness

### 3.2.5 Calendaring process

After the hydroentanglement, the samples were ready for undergoing the calendaring process. The calendaring process involves two hot rollers, which make 100% contact with the nonwoven fabric. The following parameters (Table 3.6) were used during calendaring of the nonwoven fabrics.

**Table 3.6** Specifications of calendaring machine

Parameters	Specifications
Top Roller Temperature (°C)	110 °C
Bottom Roller Temperature (°C)	110 °C
Speed (m/min)	3
Pressure (Ton)	1
Width (cm)	20
Roller Surface	Plain
Passes	One

The samples were cut into 20 cm width because of the size limitation of the calendaring machine. Before processing of the fabric, the contact of the rollers with each other was checked by using a special carbon paper as shown in Figure 3.8, which shows that the applied pressure is uniform and the fabric will be in full contact with the rollers during the calendaring process.

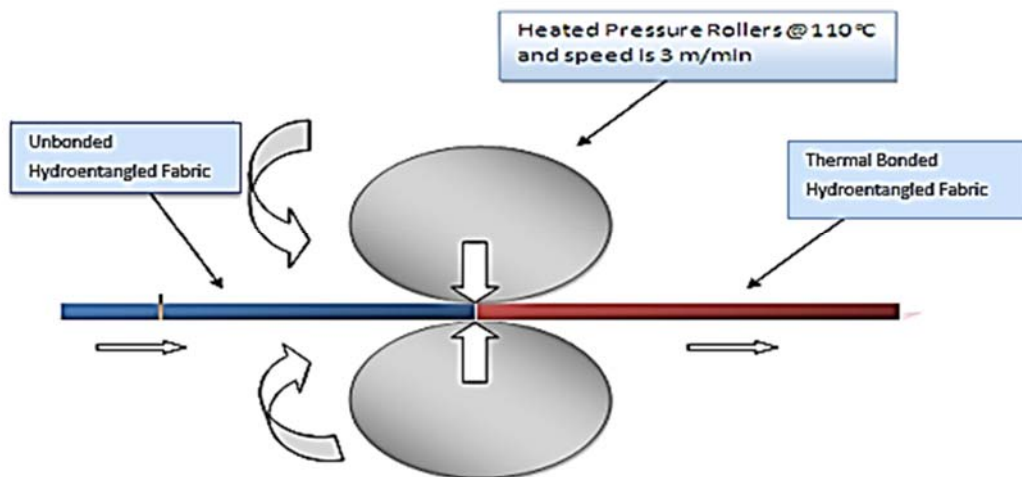


**Figure 3.8** Carbon paper showing roller contact

After making sure that the rollers are in good contact, the samples were passed through the rollers as illustrated in Figure 3.9. After the calendaring process, the nonwoven sample showed enhancement in the following properties:

- Imparted sheen to the fabric.
- Minimised the hairiness of the fabric surface.
- Made the fabric appearance smooth.
- Enhanced the fabric's tensile properties.

The nonwoven samples consisted of 70% Tencel® fibres and 30% Bi-component sheath/core (PE/PET) fibres. The main purpose of the calendaring process was to impart more strength to the fabric by using the bicomponent fibres. The rollers temperature were kept at  $110^{\circ}\text{C} \pm 5^{\circ}\text{C}$ , just below the melting temperature of the PE sheath ( $110^{\circ}\text{C}$ ). At this temperature, the "PE" sheath part of the bicomponent fibre was nearly melted and created thermal bonding between the neighbouring fibres. The "PE" acts as the binder. This results in the enhancement of the tensile properties of the calendared fabric samples. However, some reduction in the porosity of the nonwoven fabric was observed due to the calendaring process.



**Figure 3.9** Bonding mechanism of calendaring machine<sup>176</sup>

There were some other drawbacks of the calendaring process that affected the nonwoven's aesthetic properties, in which loss in the drapability was a major drawback. This was due to the fact that calendaring restricted the movement of the fibres within the fabric structure and made the fabric stiffer, resulting in a decrease in

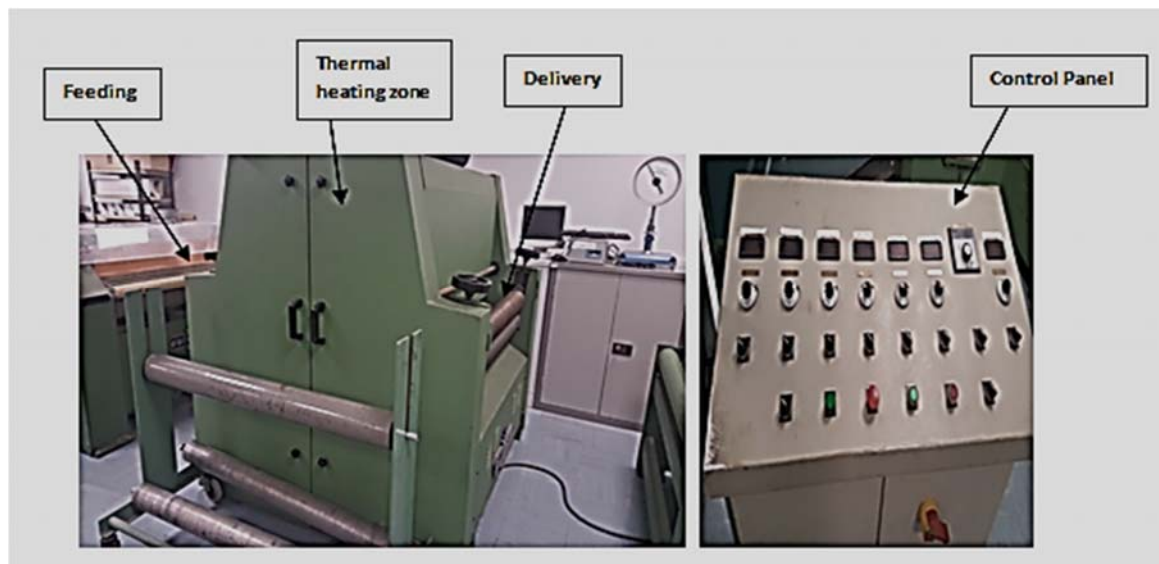
the drapability of the fabric. However, the extent of the drape loss can be controlling by varying the rollers contact, for example, 50% rollers contact will result in nonwoven fabric with much better drape characteristics than that processed with the 100% rollers contact.

The following four fabrics samples with 70% tencel and 30% bi-component blend ratio were hydroentangled at different pressures after needle punched.

1. Hydroentangled @ 50 bars calendered sample
2. Hydroentangled @ 75 bars calendered sample
3. Hydroentangled @ 100 bars calendered sample
4. Hydroentangled @ 125 bars calendered sample

### 3.2.6 Thermal bonding (Infra-red method)

Thermal bonding (infra rays) is also a very efficient and inexpensive bonding technique that is being used in the nonwoven industry. Thermal bonding through rays bonding method is better than the mechanical and chemical bonding processes because it does not have any significant effect on the aesthetic properties of the fabric as the others methods do. It gives soft and textile look to the fabric after the thermal bonding is performed. The thermal bonding machine is shown in Figure 3.10



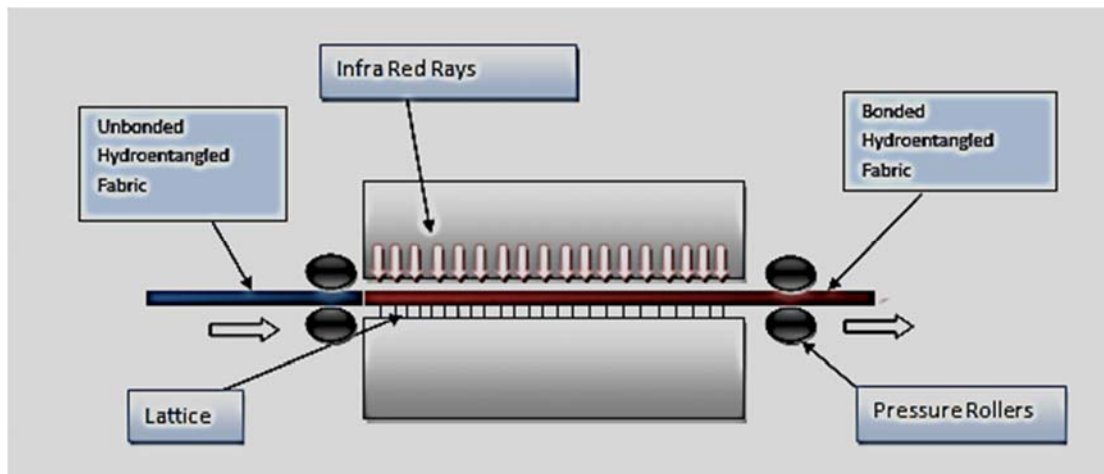
**Figure 3.10** Pilot thermal bonded machine<sup>174</sup>

In this process, the radiant heat bonding method was used and the specifications of the machine are given in Table 3.7.

**Table 3.7** Specifications of thermal bonded machine

Parameter	Specification
Conveyer Belt speed	1m/min
Time in Oven	1 min
Heat Source	Infra-Red Radiation
Temperature	110 ±5 °C
Passes	Two passes

The hydroentangled fabric samples with pre-needled and needled (0.5 m x 1 m) were passed through the thermal bonding machine. Typically, the sample was placed on the conveyer belt and then it was passed into the heating zone of the machine for 1 minute. The heated sample was then delivered out through the pressure rollers as shown in Fig 3.11. The heating source used was infrared rays and the intensity of heating was controlled by the electric panel attached to the machine.



**Figure 3.11** Thermal bonding process<sup>176</sup>

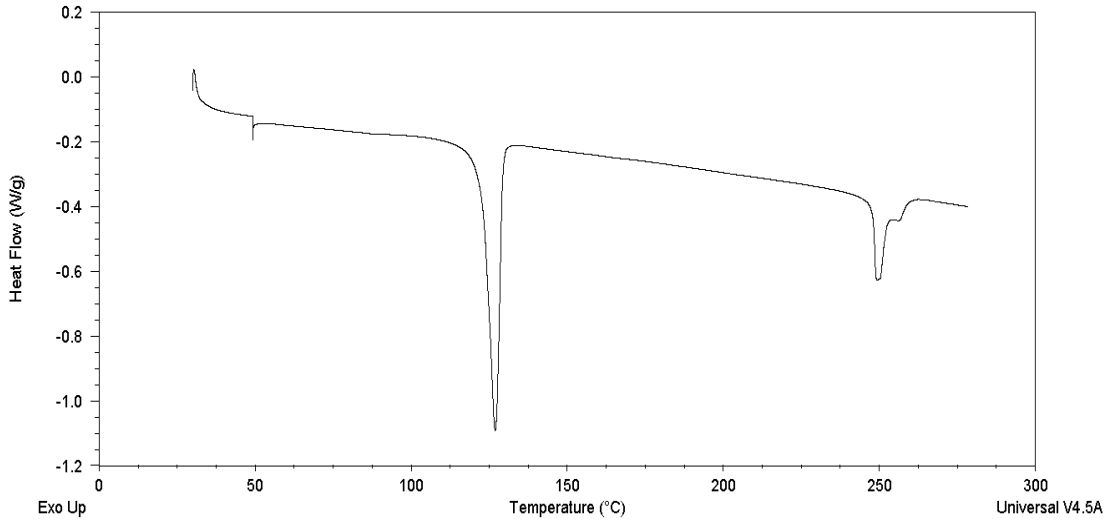
The heating temperature was set according to the melting point (115 °C) of the low melting sheath part “PE” of the bicomponent fibre. The melting behaviour of the sheath/core (PE/PET) bicomponent fibre was determined by using the differential scanning calorimetry (DSC) technique. The method can be divided into two parts: first



part relates to the sample preparation and the second part relates to the DSC procedures. The procedure is given below,

1. Weigh the sample in Aluminium pan and place a lid on the pan.
2. Place the pan with covered lid in compressed machine to seal the pan and lid.
3. Place the sealed pan in the sample tray.
4. Place the empty pan in the reference slot.
5. Start the DSC process through computer.

A typical DSC curve of the fibre is illustrated in Figure 3.12, which shows two melting peaks. The peak at 120 °C is due to the melting of PE sheath and that at around 250 °C is due to the melting of PET core of the bicomponent fibre.



**Figure 3.12** DSC curve of bicomponent sheath/core (PE/PET) fibres

On the basis of these results, the heating temperature was set between 110 °C and 115 °C. At this temperature, the fibres were not completely melted so they were softened and created bonding with other neighbour fibres through thermal bonding.

The thermally bonded nonwoven samples exhibited good aesthetic appearance as compared to the calendared samples. The hand feel of the samples was softer and gentler than the calendared fabric. The drapability of the samples also appears to be better than the calendared samples. However, the smoothness of the fabric surface of the thermally bonded samples was not as good as that of the calendared samples. This due to the fact that in the thermal bonding process, the fibres melt and create soft

bonding with neighbour fibres without the application of any significant pressure. At the fabric delivery point, only slight pressure is applied through the pressure rollers in order to obtain even bonding between the fibres.

During the thermal bonding process, the melted bicomponent fibres cover more space as compared to the non-melted fibres. However, the bicomponent fibre content of the hydroentangled nonwoven fabric was relatively low (30%), therefore, there was a little chance that this will reduce the air permeability of the nonwoven fabric after the thermal bonding process.

### **3.2.7 Reference samples**

For comparison of two fabrics, the first one is commercial available nonwoven fabric that can be used as an outer fabric for garments manufacturing and the second fabric was the woven fabric for comparing the aesthetical properties with developed hydroentangled fabrics.

The basic purpose of selecting and comparing the developed hydroentangled fabric with commercial hydroentangled was to find out the flaws in the existing best available nonwoven fabrics (Evolon) and then fulfils the flaws in the developed hydroentangled fabrics.

Woven fabric is the traditional fabric that is being used in the apparel industry. The basic reason of choosing this fabric is to find out the aesthetical properties by using British Standards testing procedure and set a scale for developed hydroentangled fabrics. The details of the reference samples are given below,

#### **3.2.7.1 Evolon®**

From the literature review, it can be concluded that Evolon is the best commercial nonwoven fabric that can be used in the apparel industry as outer fabrics. It has been discussed in literature review that Evolon fabric is developed by using high tech spunlaying and hydroentanglement processes. Bi-component, island in the sea PET/PA filament fibres were used. According to Freudenberg, Evolon is breathable and possessing high liquid absorption, fast dry and anti-mite properties<sup>29</sup>.

Freudenberg also demonstrate that Evolon can be used as an outer garment because of its aesthetical and mechanical properties.

### **3.2.7.2 Woven**

Plain weave woven fabric was chosen because of setting the acceptable scale for of require properties of the developed fabrics. The selected woven fabric was made through simple plain 1x1 weave. Woven fabric was comprised on cotton fibres, cotton is a cellulose fibre and can be compared with the Tencel fibres.

## **3.3 Test methods**

### **3.3.1 Introduction**

The purpose of this part of the chapter is to describe the test methods used for the determination of the mechanical and aesthetical properties of the developed and commercial fabrics. Different testing standards and process parameters were used to study the fabric structures and properties. There are various tests through which the fabric can be evaluated, however, from the apparel point of view, the following mentioned tests are important:

- Flexural Rigidity test.
- Air Permeability test.
- Tensile test.
- Absorbency test.
- Wicking test.
- Thermophysiological tests (SGHP method).
- Tearing tests.
- Scanning electron microscopy (SEM).
- Thermogravimetric Analysis (TGA).
- Differential scanning calorimetry (DSC).

### **3.3.2 Flexural rigidity**

The flexural rigidity of the nonwoven fabric is an important parameter, which affects the drape of the fabric. In this study, a fixed-angle flexometer apparatus (Shirley Stiffness Tester) was used to determine the bending rigidity according to the British Standard (BS 3356:1990). A marked slider was used to determine the length of the fabric strips. The apparatus is illustrated in Figure 3.13.

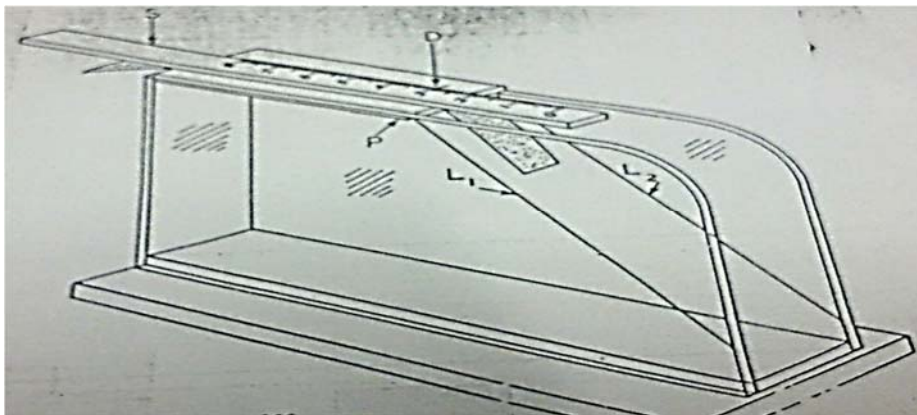


**Figure 3.13** Shirley flexometer and slider used in fabric bending measurement<sup>174</sup>

Fabrics with different bending values were tested and compared with each other. The rectangular specimens were cut according to the standard specifications ( $25 \pm 1$  mm wide and  $200 \pm 1$  mm long) from the fabric to be tested. Three samples were cut in both the machine (MD) and cross machine (CD) directions, from different parts of the fabric. The samples were conditioned for 24 hours in a standard atmosphere before testing. The standard atmosphere was  $65 \pm 2$  % relative humidity and  $20 \pm 2$  °C.

### 3.3.2.1 Test procedure

The fabric to be tested was laid on the smooth horizontal surface of the instrument “P” with its edge aligned with the end of the platform and a graduated ruler was used to support and push the tested strip, as shown in Figure 3.14. When tip of the strip hung over to meet the plane, making  $41.5^\circ$  angle with the horizontal plane lines  $L_1$  and  $L_2$ , the bending length indicated on the scale “S” was noted. The procedure was repeated with the specimen placed the other way up. Four readings were taken for each strip.



**Figure 3.14** Procedure for determination of bending length of a fabric<sup>177</sup>

The flexural rigidity of the nonwoven fabric was calculated by using the following equation:

$$G = 0.1 M C^3 \text{ (mg cm)}$$

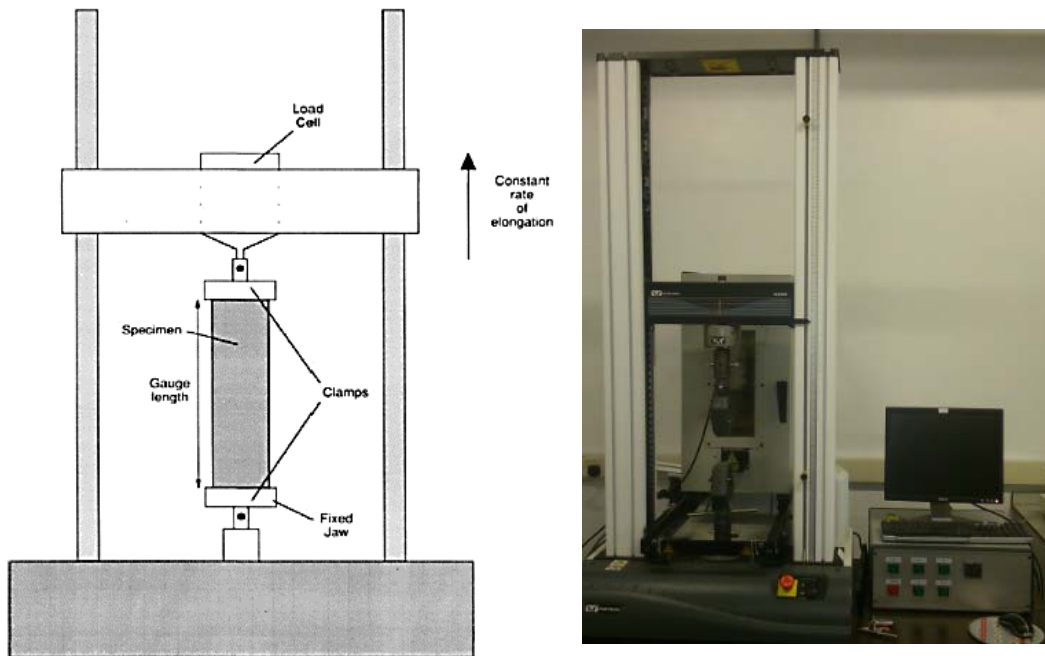
Where,

M = Mass per unit area of fabric ( $\text{g/m}^2$ )

C = Bending length (cm)

### 3.3.3 Tensile testing

The tensile tests were carried out by using a constant rate of extension method according to the British Standard EN ISO 13934-1:1999. Instron 4301 apparatus, shown in Figure 3.15, was used for the determination of tensile properties of the various fabrics investigated in this study.



**Figure 3.15** Tensile test Instron apparatus <sup>174,178</sup>

The load cell used was 50 kN and the gauge length was  $200\text{mm} \pm 1\text{mm}$ , while the testing speed employed was  $200\text{mm/min} \pm 1\text{mm}$ .

For each fabric, the test samples were cut and divided into two sets. One set was from the machine direction (MD) and the other set was from the cross direction (CD). Each set consisted of three test specimens. The test specimens were cut from different places of the fabric, in order to ensure the uniformity and reliability of the results. According to the British Standard EN ISO 13934-1:1999, the width of each test specimen was kept at  $50\text{mm}\pm 0.5\text{mm}$  and the length was  $300\text{mm}\pm 1\text{mm}$ . The extra 100 mm of the fabric was for clamping the sample in the machine jaws. The samples were conditioned at  $20^{\circ}\text{C}$  and  $65\pm 2\%$  humidity for 24 hours prior to testing.

#### 3.3.3.1 Test procedure

In a typical test, the specimen was mounted with a pretension of just about zero force. After mounting the sample, it was verified that the pretension did not produce elongation greater than 2%. Furthermore, it was ensured that the specimen was in the centre of the jaws and jaws were securely tighten, so that there was no slippage of the sample. The machine was then started in order obtain the maximum force and elongation at rupture. Three samples, both from the MD and CD, of the fabric were tested and the results were recorded.

#### 3.3.4 Air permeability

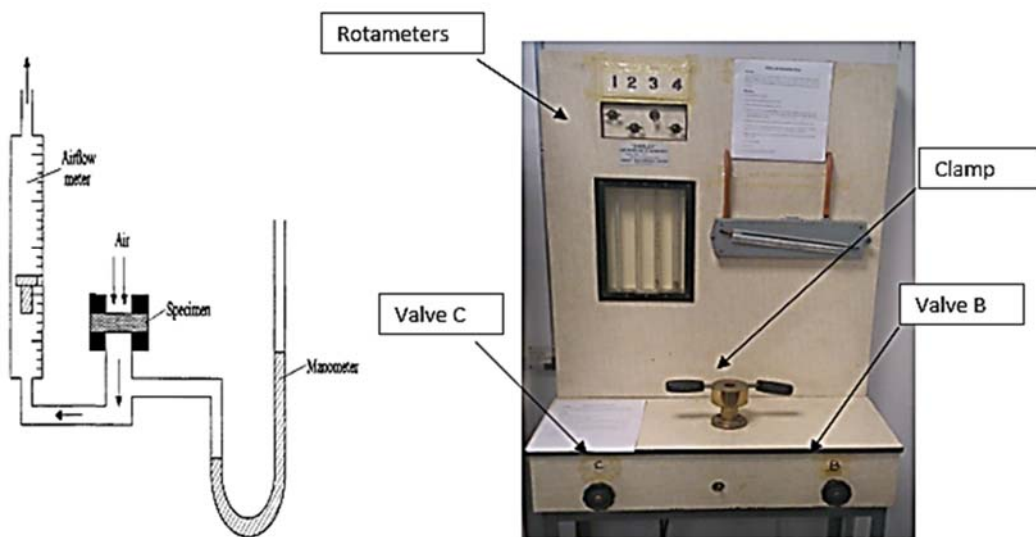
The average temperature of human body is  $37^{\circ}\text{C}$  and the body tries to maintain this temperature. If the body temperature is above that of the external environment, then it tries to maintain the body temperature through internal source of heat. The heat lost by the body and heat gained from the environment must be in balance. If they are not in balance, then the body temperature will either rise or fall, which can be a danger for life in extreme cases (121). Clothing plays an important role in maintaining the body temperature.

Air permeability is the one of fabric properties that helps the body to maintain the body temperature in balance. According to BS EN ISO 9237, the air permeability is defined as: “velocity of an air flow passing perpendicularly through a test specimen under specified conditions of test area, pressure drop and time”. The air permeability of the fabrics was determined according to the British standard BS EN ISO 9237, 1995. The apparatus used is illustrated in Figure 3.16.

### 3.3.4.1 Test procedure

Before starting the test, valve “B” was opened and Valve “C” was closed.

1. The specimen was mounted in the clamp as shown in Figure 3.16.
2. R4 was opened and other rotameters were closed.
3. Valve “C” was opened slowly until a pressure drop of 10cm of water indicated.
4. The procedure was repeated until the most suitable range for the fabric was achieved.
5. If the pressure of water was not achieved by using rotameter “R4” then “R4” was closed and the pump was switched off and valve “C” was closed.
6. “R3” was opened and the whole procedure was repeated.
7. For low resistance fabric, the valve “C” does not work therefore valve “B” was closed the slowly until the require pressure drop was achieved.



**Figure 3.16** Air permeability test<sup>174,179</sup>

### 3.3.4.2 Problem in assessing the result

The structure of a nonwoven hydroentangled fabric was not uniform as the fabric produced at a different water pressure had different structures. Therefore, it was not possible to achieve the standard pressure drop of 10mmH<sub>2</sub>O for all the fabric samples.

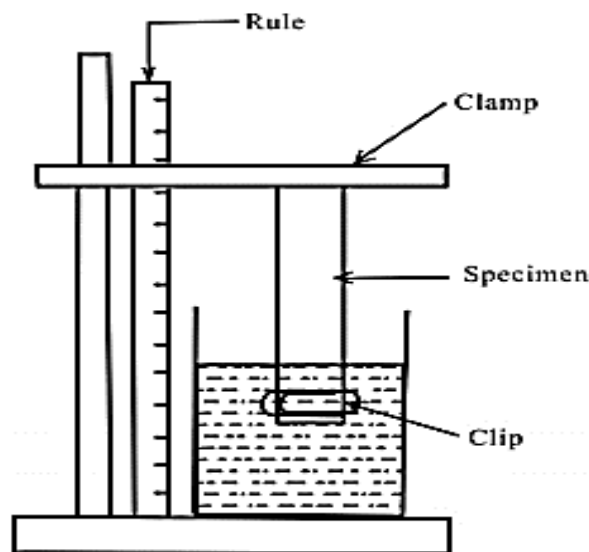
It was decided to first take values at acceptable pressure drop for all the nonwoven fabrics.

The fabric produced at 100 bars pressure was not able to give the standard results of air permeability. Therefore, in order to obtain the standard results, two to three layers of fabric samples were used to determine the air permeability values. Secondly, the porosities of the nonwoven samples are not like those of woven samples, since the nonwovens are composed of staple fibres and the woven fabric are comprised of yarn structures. Because of the fibrous structure, nonwoven fabrics have more pores per unit area than the woven fabrics.

### 3.3.5 Moisture management

#### 3.3.5.1 Wicking

Wicking is the ability of a fabric for maintaining capillary flow, since it increases the spreading of water throughout the fabric, which helps in enhancing the evaporation of moisture and as a result, provides a dry feeling to the body (90). Vertical wicking test was carried out according to BS EN ISO 9073-6:2003 and was performed by using the apparatus shown in Figure 3.17.



**Figure 3.17** Vertical wicking apparatus<sup>180</sup>

Five samples were cut according to the test specifications ( $150 \pm 1$  mm x  $30 \pm 1$  mm) in the machine and cross machine directions. These samples were conditioned at  $20^{\circ}\text{C} \pm 2^{\circ}\text{C}$  and  $65\% \pm 2\%$  humidity for 24 hours prior to testing.



### 3.3.5.1.1 Test procedure

1. The test sample was clamped vertically to the horizontal support (Figure 3.17).
2. The bottom part of sample was clipped for maintaining the test sample vertical.
3. The sample was placed nearly parallel to the measuring rod and a line ( $100 \pm 1$  mm) was marked below the zero point of the measuring rod.
4. The horizontal support was lowered until the zero point of the measuring rod touched the liquid surface and the extra 10 mm piece of fabric was dipped in the water.
5. When sample was dipped in the water the stop watch was started for determining the time.
6. The sample was left in the water for 5 minutes and the maximum capillary height of liquid and time were recorded.
7. The test was repeated with the other samples of the fabric.

The results were calculated by using the following equations.

**Equation 1:**  $\text{Wicking (g.cm)} = (m_2 - m_1) \times h$

Where,

$m_1$  : Dry weight of fabric (g)

$m_2$  : Wet weight of fabric (g)

$h$  : wicking height (mm)

Note, after wicking the specimen strip was reduced to 140 mm from 150 mm. So,

$$= M_1 : (h_2/h_1) \times m_1$$

Where,

$h_2$ : specimen strip length after wicking test (mm)

$h_1$  : specimen strip length before wicking (mm)

Now,

**Equation 2:**  $\text{Wicking (g.cm)} = (m_2 - M_1) \times h$

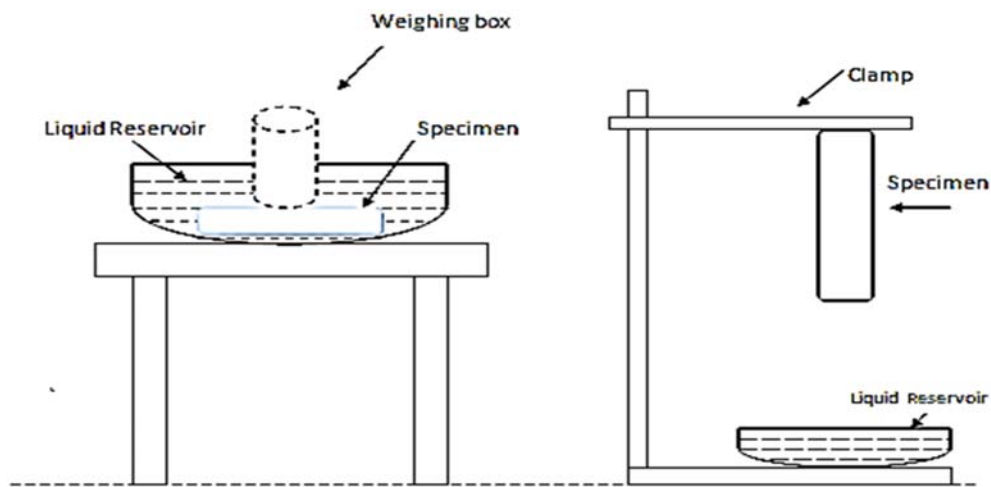
**Note: convert the “mm” units into “cm” of values “h”**

### 3.3.5.2 Absorption

Absorption relates to the amount of liquid held within a test piece after a specified time of immersion. The absorption was calculated according to BS EN ISO 9073-6:2003. This method measures the liquid stored within the test specimen itself after drainage has occurred vertically. The samples were cut according to the dimensions specified in the test method (10 cm x 10 cm) and the conditioned at 25° C ± 2 °C and 65 % ± 2% humidity.

#### 3.3.5.2.1 Test procedure

1. The specimen was weighed in the dry condition
2. After weighing, the specimen was placed into the water tub
3. Gauze was placed on top of the specimen for dipping the specimen approximately 20 mm below the liquid surface in the tub and the stop watch was started.
4. After 20min the gauze was removed
5. The specimen was hanged vertically freely for 5min.
6. The wet specimen was weighed.



**Figure 3.18** Absorption test method<sup>180</sup>

The absorption percentage was calculated by using the following formula:

$$\text{Absorption Percentage: } \frac{m_2 - m_1}{m_1} \times 100$$

Where,

m1: Dry mass of specimen in grams

m2: Wet mass of specimen in grams

Total five specimens were tested for each fabric and the mean value of the five samples were taken.

### 3.3.6 Tearing test

The tearing property of the fabric depends on the fibre and the fabric structure (120). ASTM D5734-95 (2001) test standard was used to evaluate the tearing strength of the developed hydroentangled and commercial hydroentangled fabrics. For this test, a rectangular test specimen (100mm  $\pm$  2mm long and 63  $\pm$  0.15mm wide) was cut according to the cutting die. Five samples were cut and conditioned at 20  $\pm$  2°C and 65  $\pm$  2% RH.

#### 3.3.6.1 Test procedure

1. The pendulum was positioned at the starting point and the scale reading mechanism was set to its zero position.
2. The un-slit parallel side was clamped at the bottom edge and the upper edge to the top of the clamp and slit centrally located between the clamps.
3. The clamps were closed. The specimen should lie free with its upper area directed towards the pendulum to ensure a shearing action.
4. The pendulum was released until the tear is completed and pendulum has completed its forward swing.
5. The scale reading was recorded.
6. The test was repeated for other samples.

The following formula was used to determine the tearing strength of the tested fabrics:

$$F = R \times C/100$$

F = Tearing force (gf)

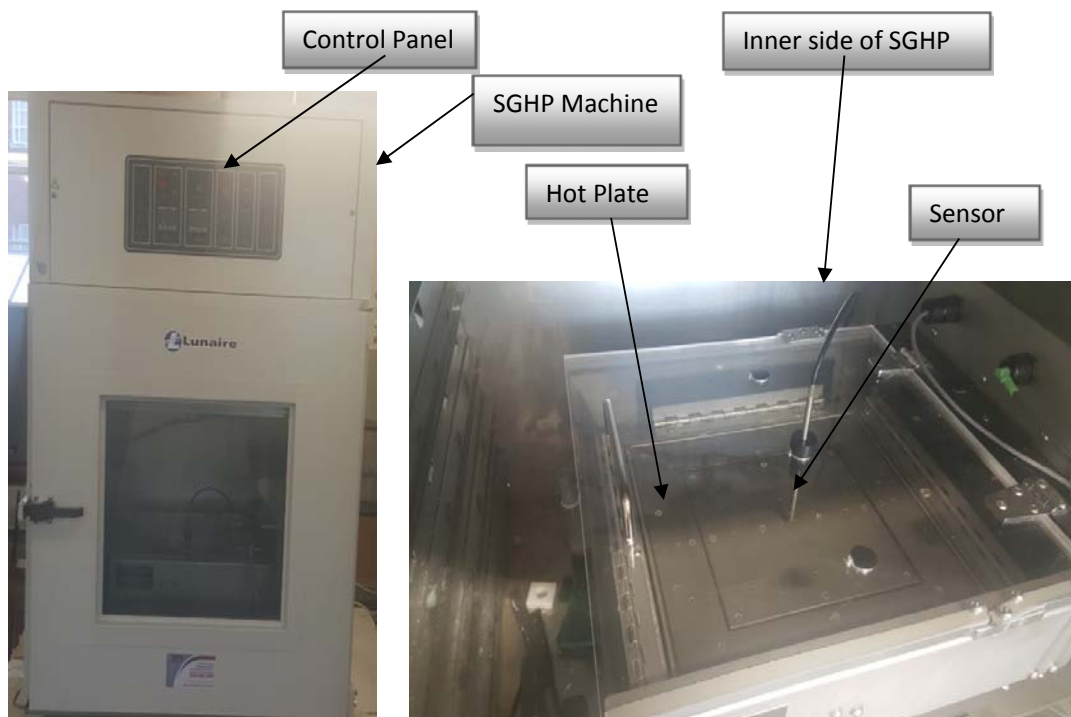
R = Scale reading

C = Full scale Capacity (gf)

### 3.3.7 Thermophysiological test

It is important to maintain the wearer body temperature at a comfort level regardless of the variation in the surrounding temperature and humidity. Thermal resistance and perspiration transfer through the fabric have a considerable effect on the comfort properties of the fabric (86). The British Standard (ISO 11092:2014) test method was used for measuring the thermal properties by using SGHP method. Following two tests were carried out by using the equipment illustrated in Figures 3.19 and 3.20.

1. Thermal Resistance ( $R_{ct}$ )
2. Water Vapour Resistance ( $R_{et}$ )



**Figure 3.19** Outside and inner view of SGHP apparatus<sup>175</sup>

Three samples of each fabric (31 X 31 cm) were cut and conditioned at 25 °C and 65% RH for 24 hours prior to testing.

#### 3.3.7.1 Test procedure of SGHP

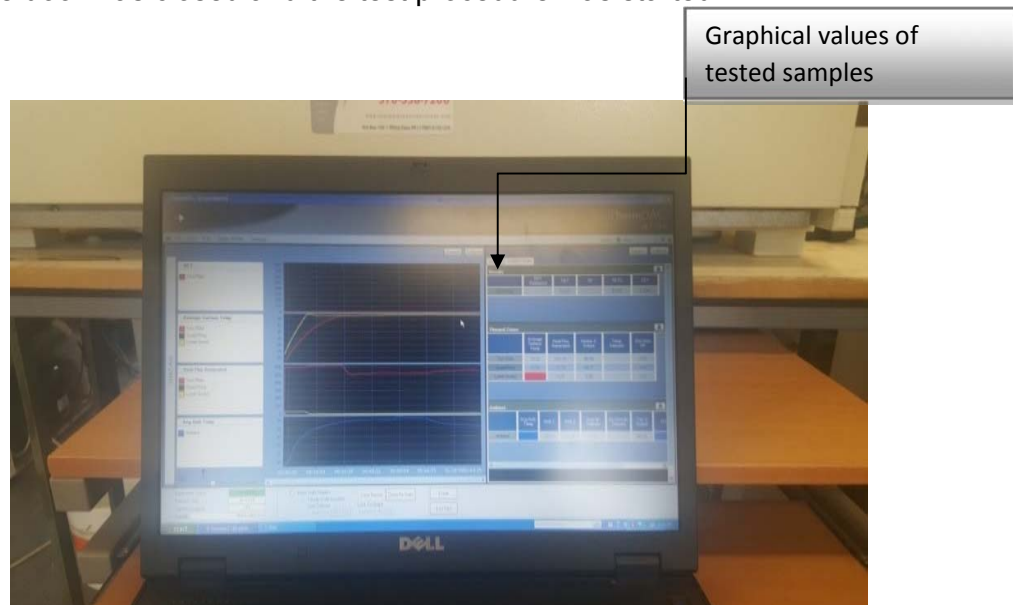
The following procedures were used for determining the thermal properties of the fabrics.

### 3.3.7.1.1 Thermal resistance $R_{ct}$ ( $m^2 \cdot K/W$ )

1. Temperatures of the measuring unit were set according to the standard ( $T_m$  at  $35^\circ C$  and air temperature  $T_a$  at  $25^\circ C$  with relative humidity R.H. of 65%). Air speed was set at 1 m/s.
2. The set values were allowed to reach a steady- state before recording the values.
3. Before placing the sample in the machine, it was made sure that the height of the sensor was 15 mm away from the sample.
4. The cut sample was placed on the hot plate for measuring the thermal resistance.
5. The door was closed and the test was started

### 3.3.7.1.2 Water vapour resistance $R_{et}$ ( $m^2 \cdot Pa/W$ )

1. Temperatures of the measuring unit were set according to the standard ( $T_m$  at  $35^\circ C$  and air temperature  $T_a$  at  $35^\circ C$  with relative humidity R.H. of 40%). Air speed was set at 1 m/s.
2. Moistened cellophane membrane was placed with distilled water on the hot plate without any wrinkles.
3. The test sample was placed on the plate.
4. The door was closed and the test procedure was started.



**Figure 3.20** SGHP software for measuring the thermal resistance of fabric<sup>175</sup>

### 3.4 Summary

It is evident that the selected materials demonstrated better hydroentangled nonwoven fabrics based on following properties:

1. Because of smooth surface of Tencel, it enhanced the soft touch to the skin.
2. Unique fibril properties provided micro channels for transportation of the moisture from the body to environment.
3. Because of hydrophilic nature, it absorbed the water and also having breathable properties.
4. Higher dry and wet tenacity than that of cellulosic fibres.
5. Because of high modulus, it consumed lower amount of energy for entangling during hydroentanglement process.
6. Bi-component sheath/core PE/PET fibres provided extra strength during hot air thermal bonding process because of low melt PE sheath part of the bi-component fibres.
7. The core part "PET" of bi-component fibres helped to maintain the structure of the hydroentangled fabric during thermal bonding process.
8. For getting better hydroentangled nonwoven fabrics different webs were produced with different blending ratio of tencel and bi-component fibres.
9. During carding process, because of manual feeding there were fluctuations in web weights.
10. Pre-needling and needle punching processes were used for obtaining intensive entangling of the fibres during hydroentanglement process and it also assist in handling the web during hydro process.
11. Needling process also helped in maintaining the fabric's structure during high pressure of water needling process.
12. Needling process reduced the bulkiness of the web that facilitate the web to pass under high pressure without being any disturbance.
13. During needling process, the parameters were set with very care because high intensity of the needling can disperse the fibres and low intensity of the needling could effects on the intensity of the entangling behaviour of the fibres.
14. During hydroentanglement process, different types of pressures were employed for analysing and obtaining the better hydroentangled nonwoven fabric.

15. During hydroentanglement process, the settings of the machine were set also with very care because belt speed effect on the mechanical properties of the fabrics.
16. After hydro process, the fabric was processed through hot air thermal and calendering process for getting higher mechanical properties. It was considered during the setting that the temperatures do not affect the aesthetical properties of the resultant fabrics.
17. During the fabric production process, the temperature and the belt speed were optimised.
18. During calendered process, the temperature and the pressures of the rollers were monitored and used appropriate temperature and pressure that optimised the mechanical properties of the resultant hydroentangled fabrics.
19. Different test methods were used to determine the mechanical and aesthetical properties of the developed and commercial fabrics.
20. Test methods that were essential for apparel fabrics were used to check the flexibility of the developed fabrics, flexural rigidity test was used.
21. For mechanical properties, tensile and shearing tests were used.
22. For determine the thermophysiological properties of the fabrics, SGHP and Alambeta tests were used.

## CHAPTER 4

### Results and Discussion

Two basic types of nonwoven fabrics were produced in this study by using different needlepunching and hydroentanglement process parameters, and they were fully characterised for their dimensional, tensile and functional properties. The properties of these fabrics were compared with the commercially available apparel type nonwoven (Evolon) and woven fabrics (plain weave 1x1). The results obtained from the characterisation studies are discussed in this chapter. Table 4.1 lists all the fabric samples investigated in this study.

Table 4.1. List of the fabrics investigated in this study

Sample	Composition	Fabric
<b>Base samples (Pre-needled and Hydroentangled)</b>		
B1	100 % Tencel	Produced at 125 bars
B2	80 % Tencel and 20% Bicomponent sheath/core, PE/PET	Produced at 125 bars
B3	70 % Tencel and 30% Bicomponent sheath/core, PE/PET	Produced at 125 bars
B4	60 % Tencel and 40% Bicomponent sheath/core, PE/PET	Produced at 125 bars
B5	50 % Tencel and 50% Bicomponent sheath/core, PE/PET	Produced at 125 bars
<b>Needlepunched-Hydroentangled</b>		
S1	70 % Tencel and 30% Bicomponent sheath/core, PE/PET	Sample produced @ 50 bars
S2	70 % Tencel and 30% Bicomponent sheath/core, PE/PET	Sample produced @ 75 bars
S3	70 % Tencel and 30% Bicomponent sheath/core, PE/PET	Sample produced @ 100 bars
S4	70 % Tencel and 30% Bicomponent sheath/core, PE/PET	Sample produced @ 125 bars
<b>Thermal Bonded (Needled Punched and Hydroentangled)</b>		
S5	70 % Tencel and 30% Bicomponent sheath/core, PE/PET	Sample produced @ 50 bars
S6	70 % Tencel and 30% Bicomponent sheath/core, PE/PET	Sample produced @ 75 bars
S7	70 % Tencel and 30% Bicomponent sheath/core, PE/PET	Sample produced @ 100 bars
S8	70 % Tencel and 30% Bicomponent sheath/core, PE/PET	Sample produced @ 125 bars
<b>Calendared (Needled Punched and Hydroentangled)</b>		



S9	70 % Tencel and 30% Bicomponent sheath/core, PE/PET	Sample produced @ 50 bars
S10	70 % Tencel and 30% Bicomponent sheath/core, PE/PET	Sample produced @ 75 bars
S11	70 % Tencel and 30% Bicomponent sheath/core, PE/PET	Sample produced @ 100 bars
S12	70 % Tencel and 30% Bicomponent sheath/core, PE/PET	Sample produced @ 125 bars
<b>Pre-needed-Hydroentangled</b>		
S13	70 % Tencel and 30% Bicomponent sheath/core, PE/PET	Sample produced @ 100 bars
S14	70 % Tencel and 30% Bicomponent sheath/core, PE/PET	Sample produced @ 125 bars
<b>Thermal Bonded (Pre-needed and hydroentangled)</b>		
S15	70 % Tencel and 30% Bicomponent sheath/core, PE/PET	Sample produced @ 100 bars
S16	70 % Tencel and 30% Bicomponent sheath/core, PE/PET	Sample produced @ 125 bars
<b>Calendared (Pre-needed and hydroentangled)</b>		
S17	70 % Tencel and 30% Bicomponent sheath/core, PE/PET	Sample produced @ 100 bars
S18	70 % Tencel and 30% Bicomponent sheath/core, PE/PET	Sample produced @ 125 bars
E1		Evolon 80 PK
W1		Woven (1x1 Plain weave)

#### 4.1 Preliminary study

Five base samples with different fibre mixing ratios were prepared at 125 bars hydro pressure for determining the best samples for further investigation in part 2. These samples were carded and bonded through pre-needed process and then finally hydroentangled at 125 bars hydro pressure.

Two main tests, tensile and flexural rigidity, were carried out with these samples for determining the best mechanical and aesthetical properties for apparel clothing applications.

The base sample B1 showed 159 g/m<sup>2</sup> area density that was higher than the other developed samples and the base sample B5 showed lower area density that was 140 g/m<sup>2</sup> as shown in Table4.2. It was expected that because of the hand fibre mixing technique and the manual feeding of the fibre to the card may cause some variation in the carded web, which can directly affect uniformity of the resultant fabrics.

The thickness values of base sample B1 was 0.8mm that was lower than all other sample despite that it showed higher fabric area density. This suggests that with increasing fabric area density the thickness values can decrease. Debnath et al (122) found that with the increase in fabric weight the thickness values were reduced. This is mainly due to the fact that in the higher area density fabric the entanglement of fibres is greater, which results in the lower fabric thickness of the fabric and vice versa. According to the table 4.2, there were no big difference in thickness of the samples. There were little variations in thickness between the developed samples and it was because of the material handling during mixing and carding process, as mentioned earlier.

#### **4.1.1 Flexural rigidity**

All base samples showed higher flexural rigidity in the machine direction than the cross direction as shown in Figure 4.1. It was because of the parallel structure of the web in which the fibres are mainly arranged in the machine direction. Parallel laid fabrics exhibit more bending length in the machine direction, because of the greater orientation and compactness of fibres in the fabric structure (98).

Sample B1 was prepared from 100% Tencel and it exhibited flexural rigidity of 1758 mg.cm, which was higher than all other developed samples (B2 to B5) as shown in Table 4.2 and Figure 4.1. Sample B2 consisted of 20% Bicomponent fibres of PE/PET and 70% Tencel fibre. This sample exhibited almost half the flexural rigidity value (877 mg.cm) of the B1 in the MD. This lower value is mainly appears to be due to the presence of the bicomponent fibres, however, it may also be result of some other factors such area density, intensity of the entanglement and fibre morphology (89,129,124). The bicomponent fibres are more flexible and crimpier than the Tencel fibres, thus the fabrics containing these fibres are expected to exhibit lower flexural rigidity values than those produced from 100% Tencel fibre.

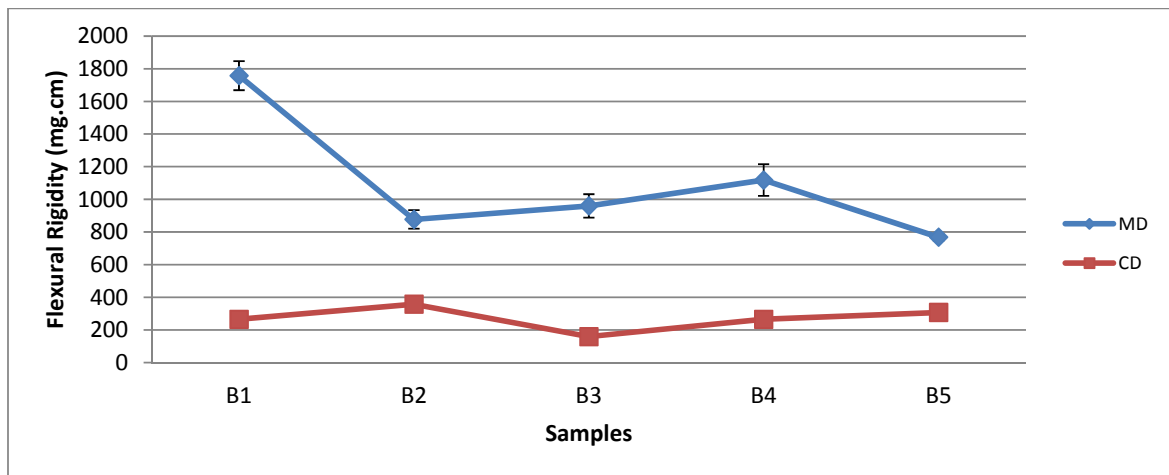
Figure 4.1 shows that by increasing content of the Bicomponent fibre in the fabric, the flexural rigidity has tendency to decrease and the optimum values are reached at 20% content level in the machine direction. However, the sharpest decrease is observed when up to 20% of the bicomponent fibre is added to the blend. Any further addition of the bicomponent fibre has no or little effect on the flexural rigidity value of the hydroentangled nonwoven prepared. As it has been mentioned earlier that the

bicomponent fibre has a crimped structure and this leads to higher mechanical bonding of these fibres with the neighbouring fibres. Maity (125) has reported that the crimped manmade staple fibres have a noteworthy effect on the mechanical and transmission properties of the nonwoven fabrics and furthermore the crimped fibres also tend to enhance the tactile properties of the nonwoven fabrics such as drapability and softness. Crimps also improves the fibre to fibre cohesion due to the hooks of the crimps, which facilitate better entanglement of these fibres during the hydro process.

**Table 4.2** Dimensional and flexural rigidity properties of base samples

Sample	Thickness mm	SD	Area Density g/m <sup>2</sup>	SD	Bulk Density gcm <sup>-3</sup>	Flexural Rigidity (mg.cm)		SD	
						MD	CD	MD	CD
B1	0.8	0.02	159	15.0	0.198	1758	265	89	26
B2	0.9	0.00	147	5.5	0.163	877	358	57	30
B3	1.0	0.02	150	6.5	0.150	960	159	72	22
B4	0.9	0.10	151	19.0	0.167	1118	265	97	14
B5	0.9	0.02	140	11.0	0.155	768	307	21	16

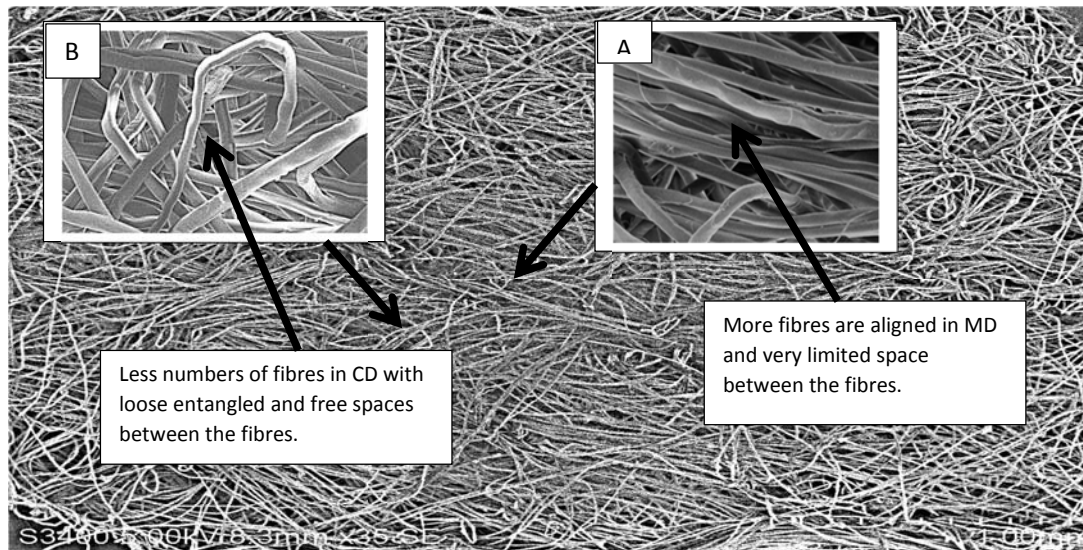
Sample B5 showed lower flexural rigidity as compared with other samples. This was mainly due to the lower bulk density and higher bicomponent fibre content of the fabric and the fact that the bicomponent fibres are crimped structures, which lower the flexural rigidity of the fabric.



**Figure 4.1** Flexural rigidity values of base samples in machine and cross directions.

Figure 4.2 presents a scanning electron microscopic image of the fabric sample B1, which shows the entangling behaviour and orientation of the fibres within the fabric

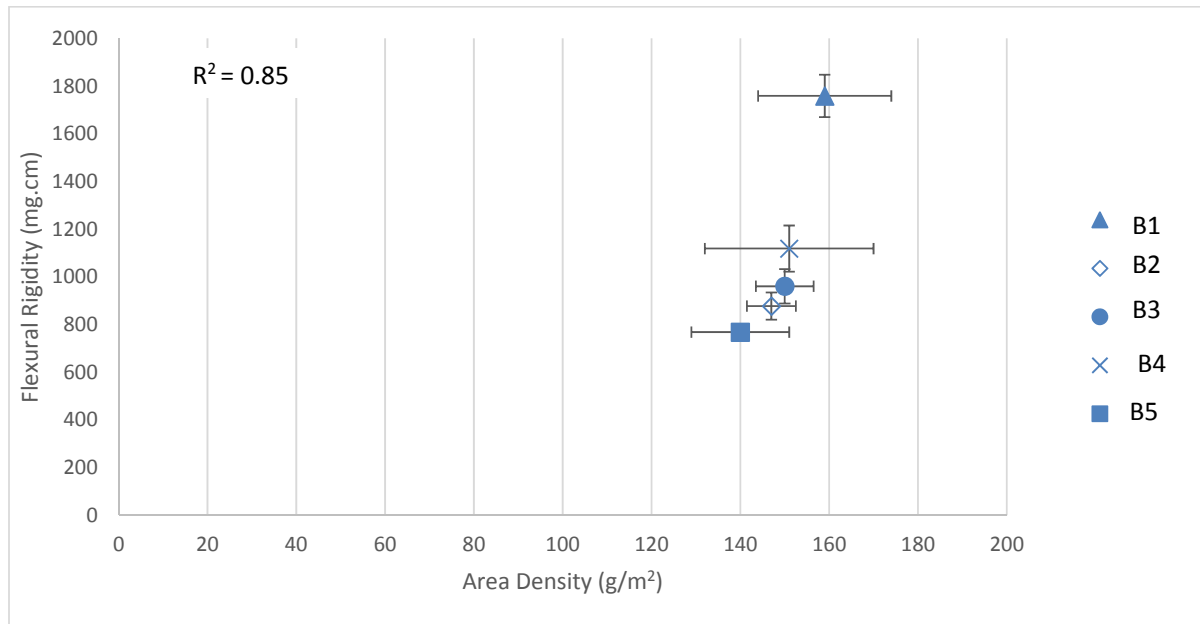
structure. Figure 4.2A shows the fibres orientation in the machine direction and Figure 4.2B shows the fibre orientation in the cross machine direction.



**Figure 4.2** SEM image of sample B1 showing fibre entangling behaviour in (A) MD and (B) CD

The results show that the fibres were more aligned and tightly entangled in the machine direction than in the cross machine direction, thus restricting the fibre movement in the machine direction and as a resulting in the high flexural rigidity values of the samples in this direction. However, in the cross machine direction the fibres were loosely entangled, which led to the lower values of flexural rigidity in all developed the nonwoven samples, as shown in Figure 4.1. It is reported that the fabric area density and the intensity of entanglement between the fibres increases the flexural rigidity of nonwoven fabrics (124).

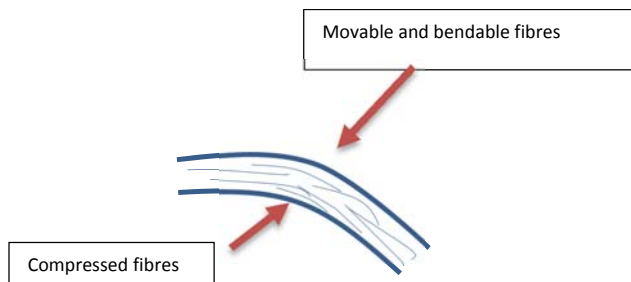
The results presented in Figure 4.3 show that with the increase in the fabric area density, the flexural rigidity of the fabric was also was increased. The coefficient of determination ( $R^2$ ) was 0.85, which mean that there is strong functional relation between the fabric weight and the flexural rigidity.



**Figure 4.3** Effect of fabric area density on flexural rigidity of the fabrics in MD

It is shown in Figure 4.1 that the addition of more than 20% bicomponent fibre to the blend did not have no effect on the flexural rigidity in the MD (B2 to B5).

According to Yuksekkaya (126), the bending of a fabric causes elongation of the fibres in the other side of the fabric. , i.e. when the fibres on one side of the fabric elongate the fibres on other side shorten. These changes in the length cause the deflection of the fabric under its own weight. But in term of a nonwoven fabric, fibres modulus, fabric area density and the space between the fibres (fabric structure) play important roles in the deflection of the nonwoven fabric (Figure 4.4). On this basis, the fibres that show higher resilience will give lower values of flexural rigidity, depending on the fabric structure. If fibres are able to move within the fabric structure then a fabric with better flexural rigidity is obtained.



**Figure 4.4** Bending Mechanism of Nonwoven Fabric

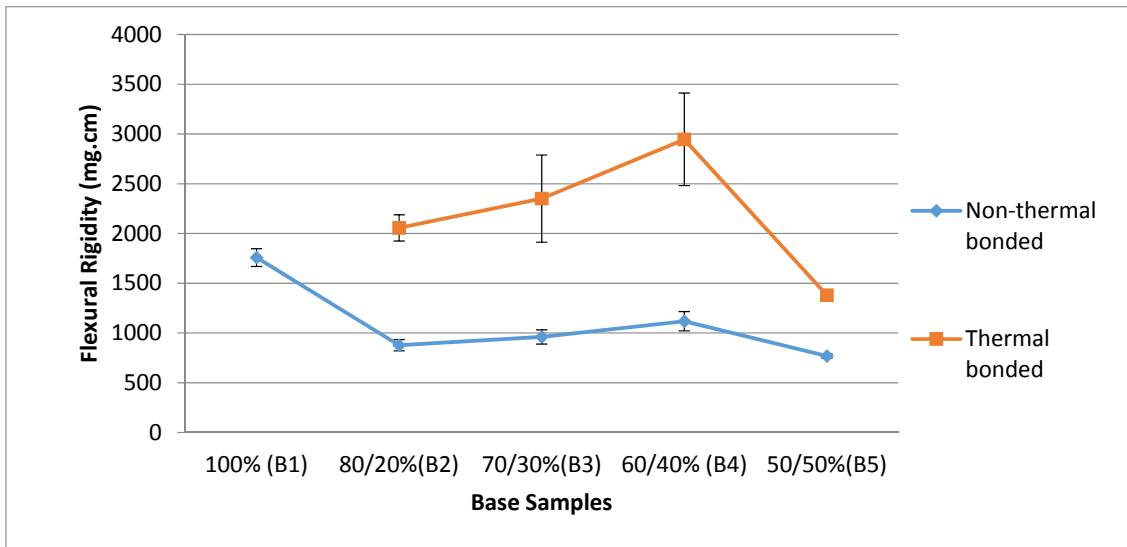
As illustrated in Figure 4.1, the fabric sample B1 gave higher value of flexural rigidity than fabric samples B2 to B5. B1 fabric was made of 100% Tencel fibres whereas B2 fabric was made by using 80/20 of Tencel and sheath/core (polyethylene/polyester) bicomponent fibres (80% Tencel and 20% Bicomponent). This is known that Bicomponent sheath/core PE/PET fibre is a softer fibre than Tencel and has higher elastic properties, as mentioned in chapter 3. Therefore, during the application of a compressive force, the Bicomponent fibre can bend with ease and enable the fabric to bend under its own weight.

The fabric structure also has a significant impact on the flexural rigidity. Smith et al (127) found that if the fibres are able to act independently in the fabric structure this lowers the flexural rigidity of the fabric. This finding was also supported by the work of Yuksekkaya et al (126), who reported that the bending properties of a fabric are very much dependent upon its structure and the fibre constituents.

#### **4.1.1.1 Flexural rigidity of thermally bonded samples**

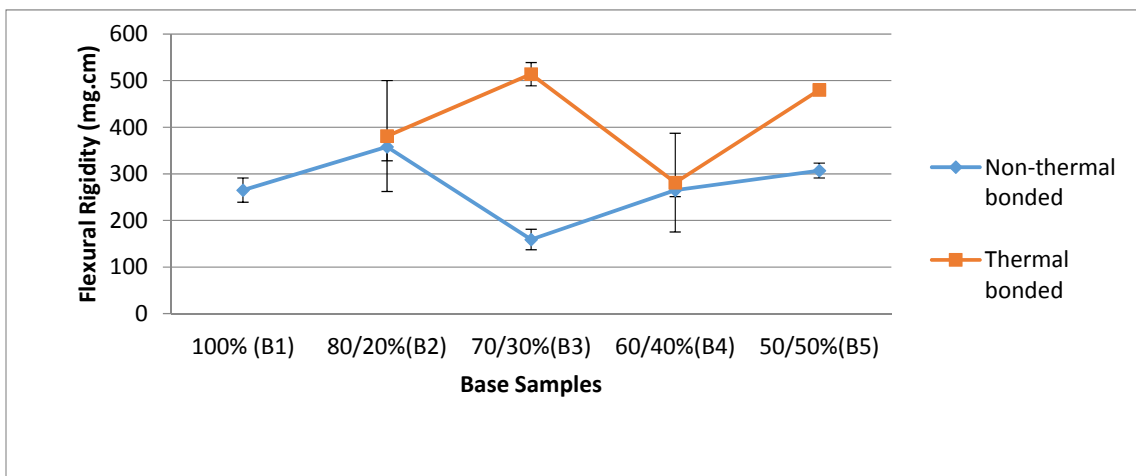
Figures 4.5 and 4.6 show that after the thermal bonding process, the blended base samples showed higher flexural rigidity in machine and cross direction as compared with to the non-thermal bonded base samples. Mao and Russell (103) found that the bending rigidity depends on the fibres physical properties and also on the manufacturing processes employed. After the thermal bonding process, the flexural rigidity was increased by 136% in MD for sample B2.

As demonstrated earlier (Figure 4.4), the fabric flexibility depends on the movement of the fibres and that when the fibre movement within the fabric structure is restricted it higher the fabric flexural rigidity (127). Thus in the thermally bonded fabrics, the fibres lose their independence to move and the ability of the fabric to bend upon the application of a compressive force is reduced. It was observed that sample B3 and B4 gave higher values of flexural rigidity in the MD, but in the cross direction sample B3 gave a higher value and sample B4 gave lower values, which was still higher than the samples that were not subjected to the thermal bonding process. Furthermore, Wei et al (128) have reported that during the thermal bonding process, the fibres morphology changes and that this has a considerable effect on the properties of the fabrics such, particularly their mechanical properties.



**Figure 4.5** Flexural rigidity values of base samples after thermal bonding process in MD

Figure 4.5 shows that flexural rigidity of the nonwoven fabric increased, both in the MD and CD, as the bicomponent fibre content was increased up to sample B4. However, a sudden decrease in the flexural rigidity values observed for sample B5 (50:50 Tencel -bicomponent). This appears to be due to the presence of excessive amount of the bicomponent fibre in sample B5, which could be due to lack of molecular orientation in the fibre structure (Bicomponent) as more amorphous regions were developed that gave flexibility in the fibres and this led to the lower flexural rigidity value for sample B5.



**Figure 4.6** Flexural rigidity values of base samples after thermal bonding process in CD

The morphological changes in the bicomponent fibres were studied by using the DSC technique. The results presented in Table 4.3 show that as the bicomponent fibre content of the fabric were increased (from B2 to B5) the heat of fusion, as determined by DSC, was also increase in the non-thermal bonded samples. These findings agree well with those reported by Rong et al, (129), who also found that the addition of the bicomponent (PE/PET) fibres to cellulosic fibres, in a blend, led to an enhancement of the heat of fusion of the sample.

**Table 4.3** DSC, Heat of fusion of base samples before and after thermal process

Samples	Before Thermal Process				After Thermal Process			
	$\Delta H_s$ PE J/g	$\Delta X_c$ (PE) %	$\Delta H_s$ PET J/g	$\Delta X_c$ (PET) %	$\Delta H_s$ PE J/g	$\Delta X_c$ (PE) %	$\Delta H_s$ (PET) J/g	$\Delta X_c$ (PET) %
B1	-	-	-	-	-	-	-	-
B2	2.06	0.70	1.58	1.1	16.33	5.5	7.51	5.5
B3	25.02	8.5	8.17	6.0	24.00	8.1	8.69	6.4
B4	28.57	9.7	11.37	8.37	31.80	10.8	12.73	9.3
B5	37.83	12.9	14.64	10.7	30.00	10.2	11.62	8.5

$\Delta H_s$ : Heat of Fusion

$\Delta X_c$ : Crystallinity

However, after subjecting the Tencel-bicomponent samples to the thermal bonding process, it was noted that both the heat of fusion and the crystallinity values of the samples up to the bicomponent level of 40%. However, any further increase in the bicomponent content caused a slight decrease in the heat of fusion and crystallinity of the sample (B5). This change in the crystallinity is possibly due to the loss of molecular orientation in the fibre structure. The crystallinity changes in the bicomponent fibres in sample B2, before and after the thermal processing, were calculated from the heat of fusion values obtained from the DSC curves (Figure 4.7 and 4.8).



**Calculation of crystallinity of bicomponent fibres of sample B2 before thermal process**

**PE**

$$\Delta H_s = 2.06 \text{ j/g}$$

$$\Delta H_{100} = 293 \text{ j/g}$$

$$\Delta X_c = \frac{\Delta H_s}{\Delta H_{100}} \times 100\%$$

$$= 2.06/293 \times 100$$

$$= 0.70\%$$

**PET**

$$\Delta H_s = 1.58 \text{ j/g}$$

$$\Delta H_{100} = 135.8 \text{ j/g}$$

$$\Delta X_c = \frac{\Delta H_s}{\Delta H_{100}} \times 100\%$$

$$= 1.58/135.8 \times 100$$

$$= 1.16\%$$

**Calculation of crystallinity of bicomponent fibres of sample B2 after thermal process**

**PE**

$$\Delta H_s = 16.33 \text{ j/g}$$

$$\Delta H_{100} = 293 \text{ j/g}$$

$$\Delta X_c = \frac{\Delta H_s}{\Delta H_{100}} \times 100\%$$

$$= 16.33/293 \times 100$$

$$= 5.57\%$$

**PET**

$$\Delta H_s = 7.51 \text{ j/g}$$

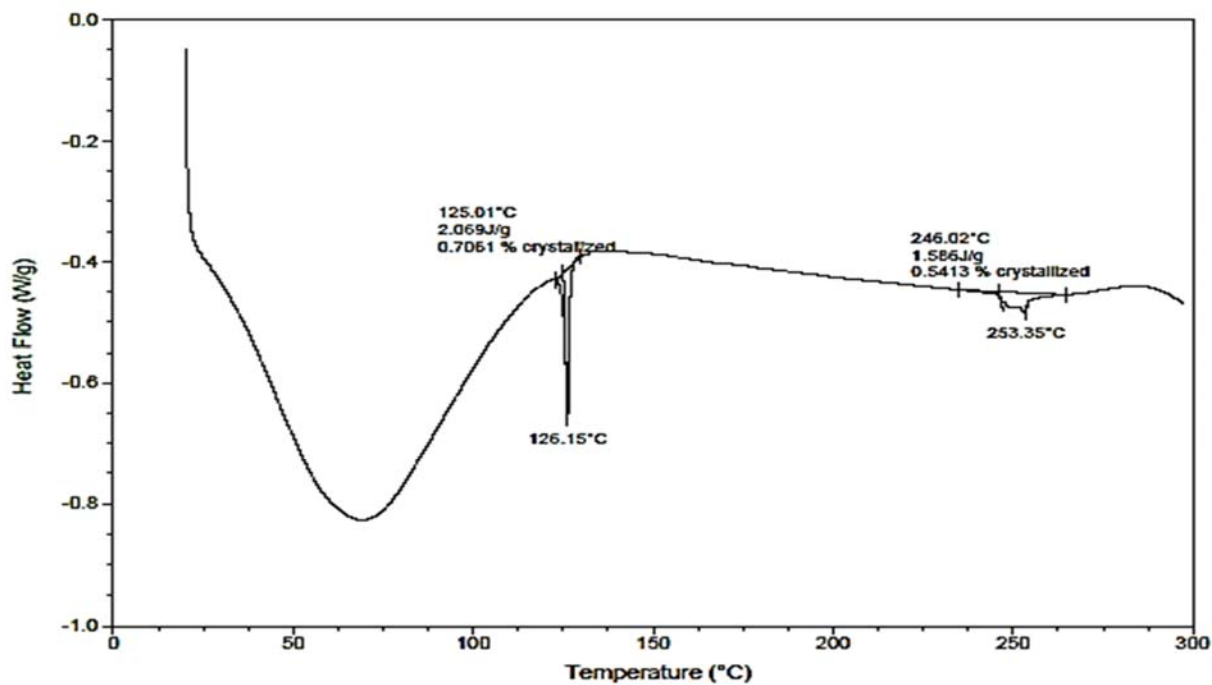
$$\Delta H_{100} = 135.8 \text{ j/g}$$

$$\Delta X_c = \frac{\Delta H_s}{\Delta H_{100}} \times 100\%$$

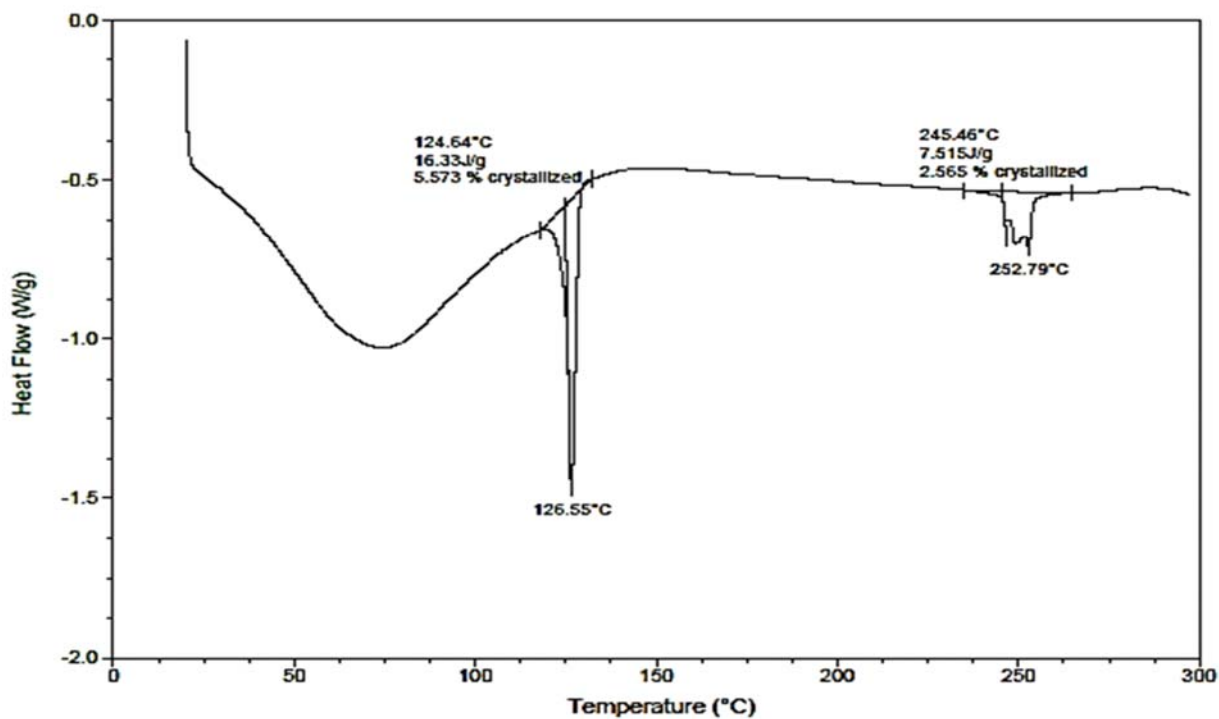
$$= 7.51/135.8 \times 100$$

$$= 5.53\%$$

It can be seen from the calculations that after the thermal bonding process the crystalline behaviour of the bicomponent fibre in the sample B2 changed, i.e. higher heat of fusion for the sample was obtained. The increase in the flexural rigidity of the nonwoven sample (B2) after the thermal processing may be related to the increase in the crystallinity of the bicomponent fibres. The DSC curves of sample B2 before and after thermal processing, are illustrated in Figures 4.7 and 4.8, respectively.



**Figure 4.7** DSC curve of sample B2 before thermal process



**Figure 4.8** DSC curve of sample B2 after thermal process

B2 samples contained 20% thermoplastic bicomponent sheath/core PE/PET fibres. When this samples was passed through thermal process at 120-125 °C, then the

sheath part PE of Bicomponent fibres were melted and created thermal bonding with the neighbouring fibres and restricted the fibre movement within the fabric structure, also resulting in the enhancement of the flexural rigidity of the fabric in the machine and cross directions.

From Figure 4.5, it is observed that B5 sample showed lower flexural rigidity in the MD as compared to the other thermally bonded fabrics. Even though sample B5 had maximum concentration of Bicomponent fibres (50%), the DSC results showed that after the thermal processing of the sample a decrease in the heat of fusion of the sample was observed. This is likely due to the loss in molecular orientation of the bicomponent fibres and as a result sample B5 exhibited lower flexural rigidity value in the machine direction. The crystallinity values were for sample B5 were calculated from the heat of fusion values obtained from the DSC curves presented in Figure 4.10.

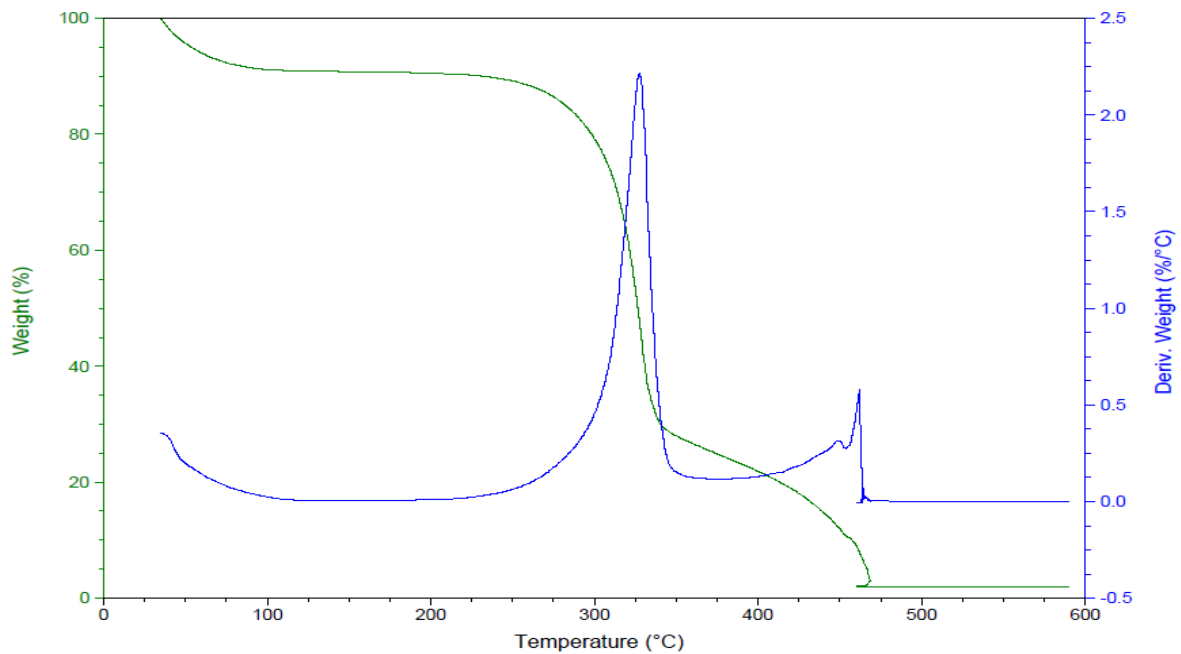
**Calculation of crystallinity of bicomponent fibres of sample B5 before thermal processing**

PE	PET
$\Delta H_s = 37.83 \text{ j/g}$	$\Delta H_s = 14.64 \text{ j/g}$
$\Delta H_{100} = 293 \text{ j/g}$	$\Delta H_{100} = 135.8 \text{ j/g}$
$\Delta X_c = \frac{\Delta H_s}{\Delta H_{100}} \times 100\%$	$\Delta X_c = \frac{\Delta H_s}{\Delta H_{100}} \times 100\%$
$= 37.83/293 \times 100$	$= 14.64/135.8 \times 100$
$= 12.91\%$	$= 10.78\%$

**Calculation of crystallinity of bicomponent fibres of sample B5 after thermal process**

PE	PET
$\Delta H_s = 30.00 \text{ j/g}$	$\Delta H_s = 11.62 \text{ j/g}$
$\Delta H_{100} = 293 \text{ j/g}$	$\Delta H_{100} = 135.8 \text{ j/g}$
$\Delta X_c = \frac{\Delta H_s}{\Delta H_{100}} \times 100\%$	$\Delta X_c = \frac{\Delta H_s}{\Delta H_{100}} \times 100\%$
$= 30.00/293 \times 100$	$= 11.62/135.8 \times 100$
$= 10.23\%$	$= 8.55\%$

Figure 4.9 is the thermogravimetric analysis (TGA) curve for Tencel fibre, which shows a three stage weight loss. The first stage refers to the loss of water adsorbed (7-8%) between 60 °C to 130 °C. This clearly demonstrates the ability of Tencel fibre to absorb water with ease. The second stage shows a much sharper weight loss due to the degradation of the fibre and is a typical feature of the regenerated cellulosic fibres (161). The second stage weight loss of Tencel fibre begins a higher temperature than the other regenerated cellulosic fibres such as viscose rayon. This is because of the higher crystallinity, smoothness of the surface, more regular shape and higher degree of polymerisation of Tencel fibre. Figure 4.9 also shows that the weight loss for the third stage is relatively low, which is mainly due to the carbonisation of the char formed at the higher temperature.



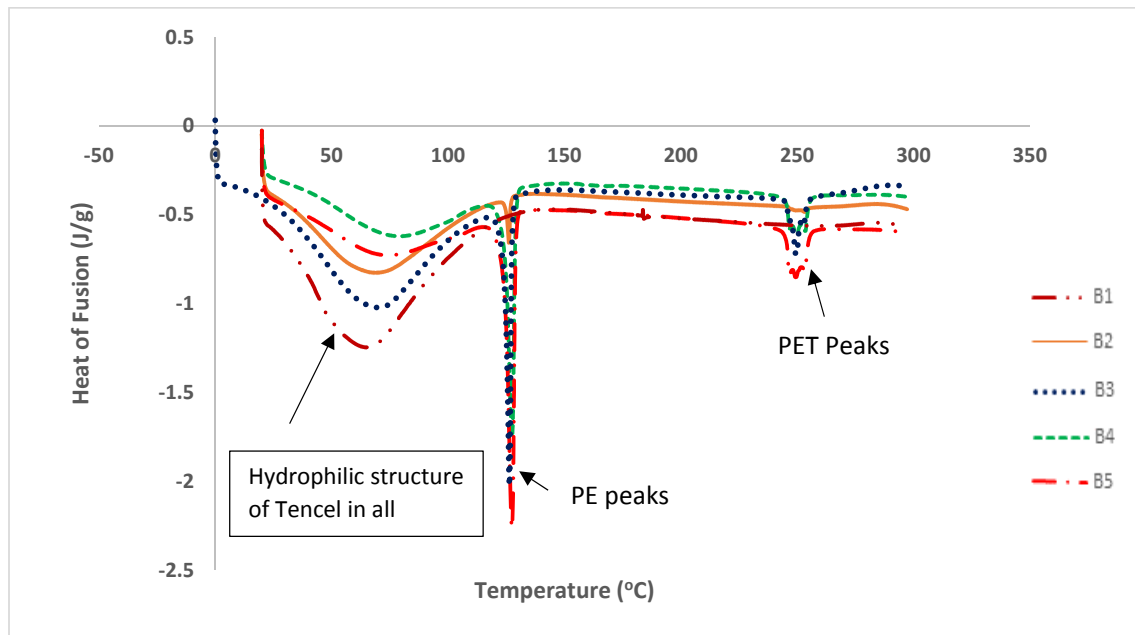
**Figure 4.9** TGA of Tencel Fibres

Thermal bonding was carried out via the IR heating method so that in order to avoid the use of high pressure heated rollers, so that the stretching force acting on the fibres can be circumvented. Zhang et al (130) reported that with the increase in the heating temperature the PE crystalline structure was changed. According to these workers the molecular chains of PE were disturbed at 400K-500K (126 °C -226 °C), which weakened the lattice order within the structure of the fibres, thus affecting the

mechanical properties of the fabric. Second, because of the lowering of the Tencel fibre content the flexural rigidity of sample B5 was reduced.

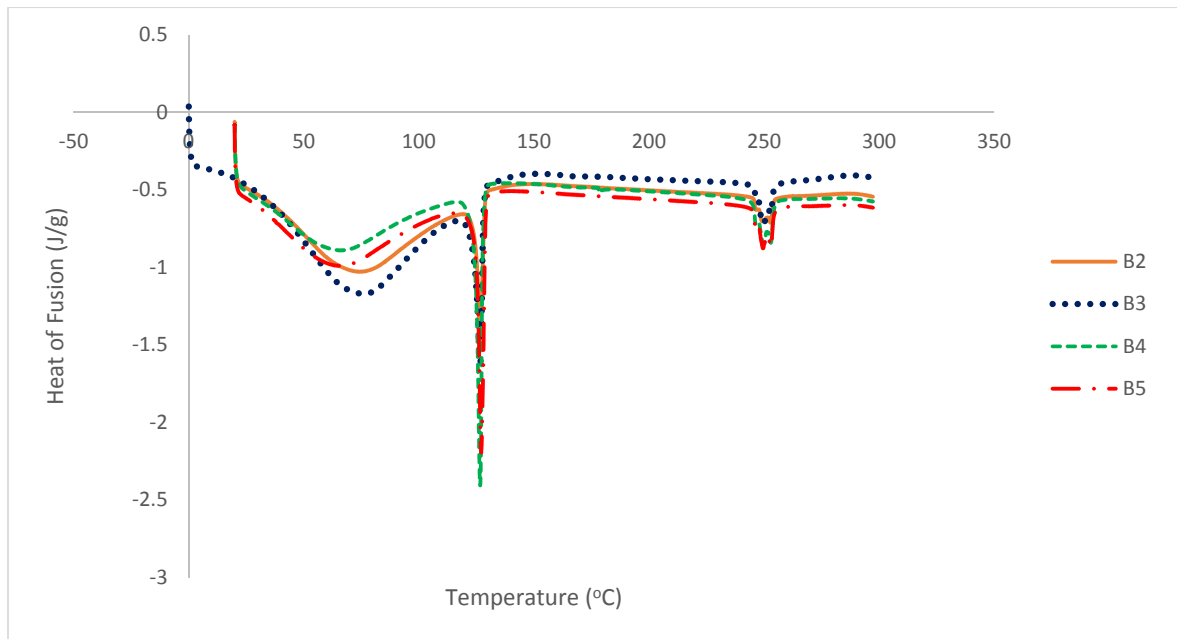
A comparison of DSC curves of all the samples, before and after thermal processing is shown in Figures 4.10 and 4.11. The results show that sample B1 containing 100% Tencel fibres exhibited highest peak in the region of water absorption and no melting peak was observed as there were no bicomponent fibres present in this sample. However, as the bicomponent fibre was introduced into the sample, two melting peaks due to the melting of PE (125°C) PET (250°C) were obtained. Furthermore, as the content of the bicomponent fibre were increased in the fabric, the melting peak heights were also increased.

Sample B3 showed a good balance of heat of fusion before and after the thermal processing of the sample (Table4.3). Figures 4.9 and 4.10 also show that there were no big differences in the heat of fusion of sample B3 before and after the thermal processing. Sample B3 also showed higher crystallinity than sample B2, but lower than samples B4 and B5. Excessive amount of bicomponent fibre also has a considerable effect on the thermophysiological and aesthetical properties of the resultant fabrics.



**Figure 4.10** DSC curves of base samples B1, B2, B3, B4. And B5 before thermal process

The basic purpose of using the low melt sheath/core PE/PET Bicomponent fibres is to enhance the mechanical properties of the developed hydroentangled nonwoven fabrics. The bonding is achieved through the sheath part (PE) of the bicomponent fibre, whereas the PET part maintains the integrity of the fabric throughout the thermal bonding process. This results in a stable fabric structure, however, the fabric's flexural rigidity is affected. The heterofil bicomponent binder fibres are more advantageous than the homofil fibres (131). It was observed by Desai et al (131) that the flexural rigidity is influenced more by the binder fibres than the fabric weight.



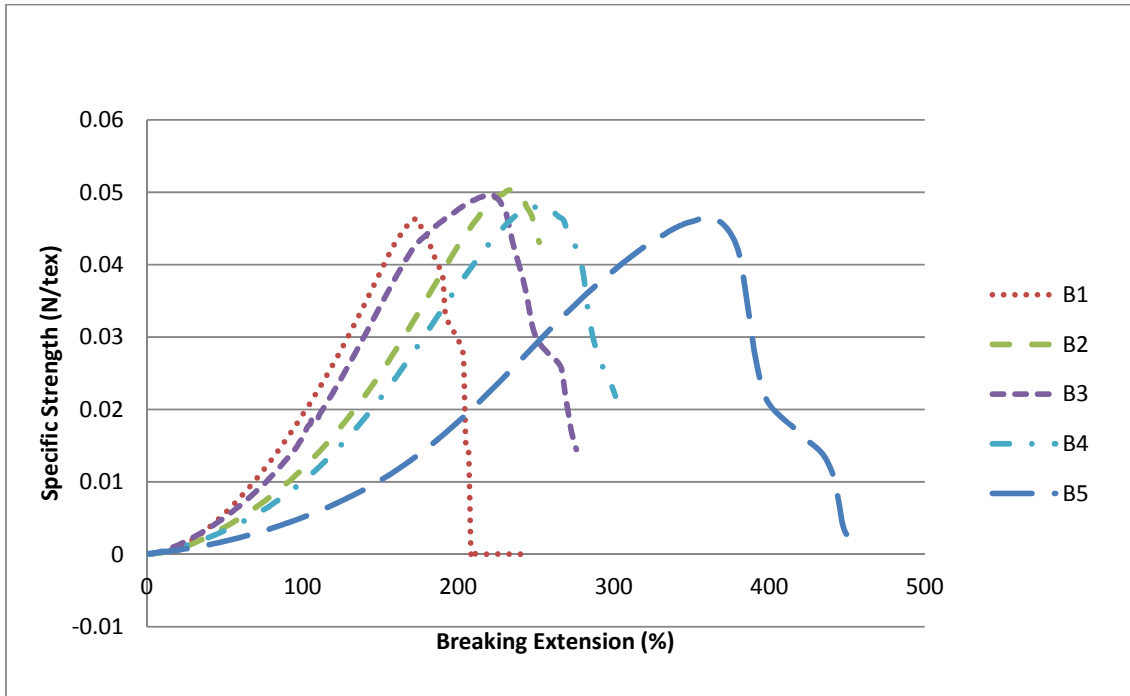
**Figure 4.11** DSC curves of base samples B2, B3, B4. And B5 after thermal process

On the basis of above discussion, it may be concluded that the thermal process has a significant effect on the mechanical and aesthetical properties of the nonwoven fabrics.

#### 4.1.2 Tensile properties

The tensile properties of the various samples (B1-B5) were determined and the results are presented in Figure 4.12. These results show that the addition of the bicomponent fibre had no or little effect on the breaking strength of the fabric in the MD. However, the extension to break values of the fabrics were increased as upon the addition of the bicomponent fibre. Furthermore, as the bicomponent fibre content of the fabric were increased the breaking extension of the sample was also increased - the sample

containing the highest amount of the bicomponent fibre exhibited the highest breaking extension in the MD. This mainly due to the presence of crimps in the bicomponent fibre, which extend as the tensile force is applied to the fabric sample. Secondly, the breaking elongation of the bicomponent is much higher than the Tencel fibre, which was 100%-160% as compared to the Tencel fibre breaking extension of about 14%.



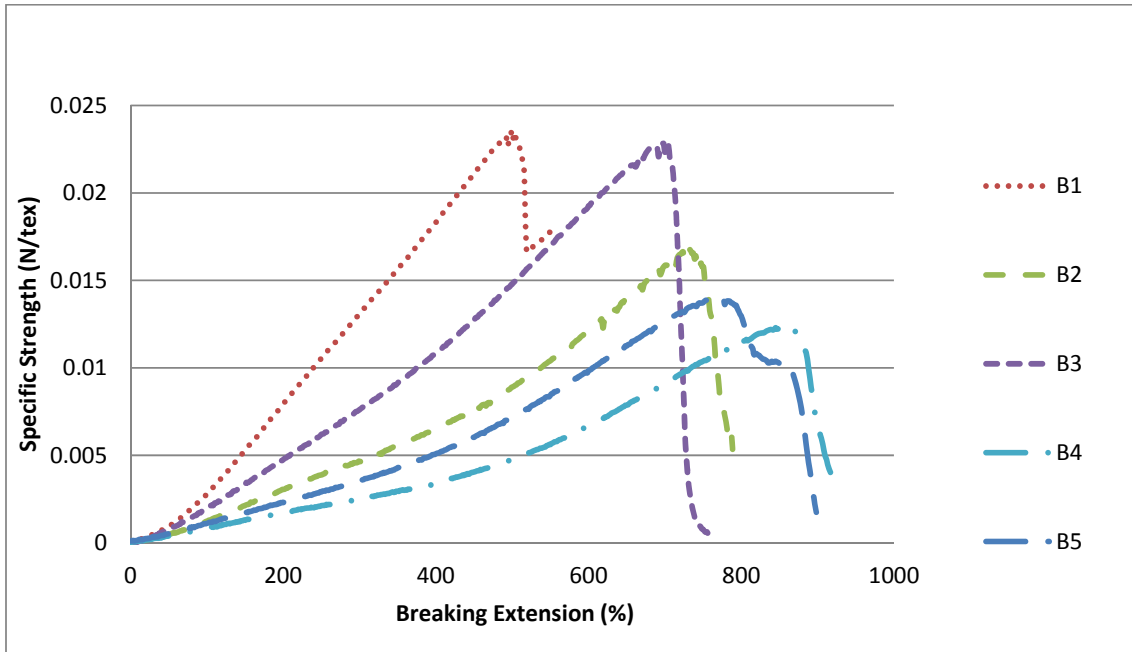
**Figure 4.12** Tensile values of developed base samples in machine direction

The tenacity values of both fibres were very similar (see chapter 3). The tenacity of the bicomponent and Tencel fibres were 2.5-3.6 cN/dtex and 3.6 cN/dtex, respectively. This is why the addition of the bicomponent fibre has very little influence on the tensile strength of all the samples prepared.

The breaking strength values of all the sample in the CD of developed samples were lower than the MD values. This due to the fact that the number of fibres present in the CD is smaller than the MD, thus the degree of fibre entanglement in the CD of the fabric is lower than the MD.

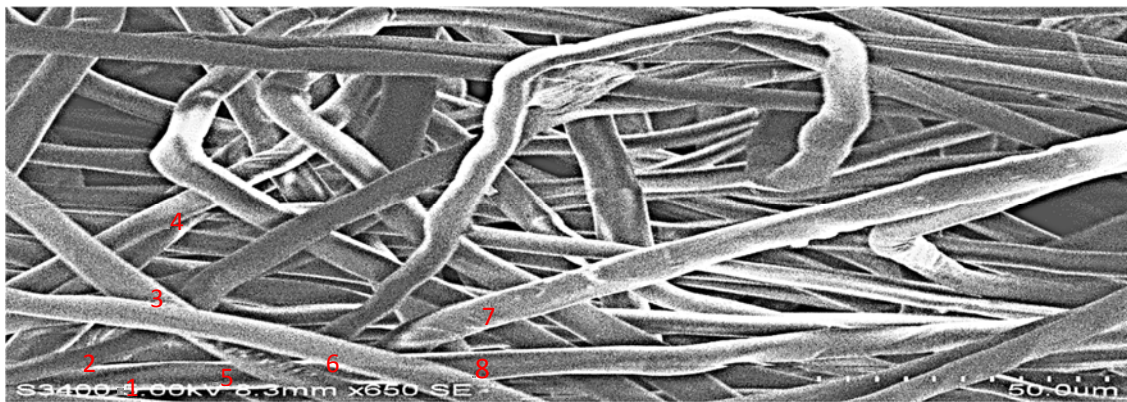
Figure 4.14 is an SEM image of sample B2, which show the positioning of the fibres in the CD. There are more spaces between the fibres in the CD and that the fibres are placed at different angles in the fabric structure and they are not well entangled, which results in their higher extension to break and lower tensile strength values, as

illustrated in 4.13. However, the breaking load value in CD of samples B3 and B1 are similar.



**Figure 4.13** Tensile values of developed base samples in cross direction

It may be concluded that by balancing fibre blend ratio, the fabric’s mechanical and aesthetical properties can be optimised. The fabric sample B3 (70:30 Tencel/bicomponent) exhibited a good combination of flexural rigidity and tensile characteristics.



**Figure 4.14** SEM of CD region of Base sample B2 for analysing the fibres positions in fabric structure



Wang et al (132) found that the tensile strength of different hydroentangled nonwoven fabric prepared at the same pressures can be expressed by the bonding index (BI) that can be defined as:

$$BI = (MD + CD)/2 \quad (1)$$

Influenced by weight, then

$$BI = (MD + CD)/W \text{ (N/g.m}^2\text{)} \quad (2)$$

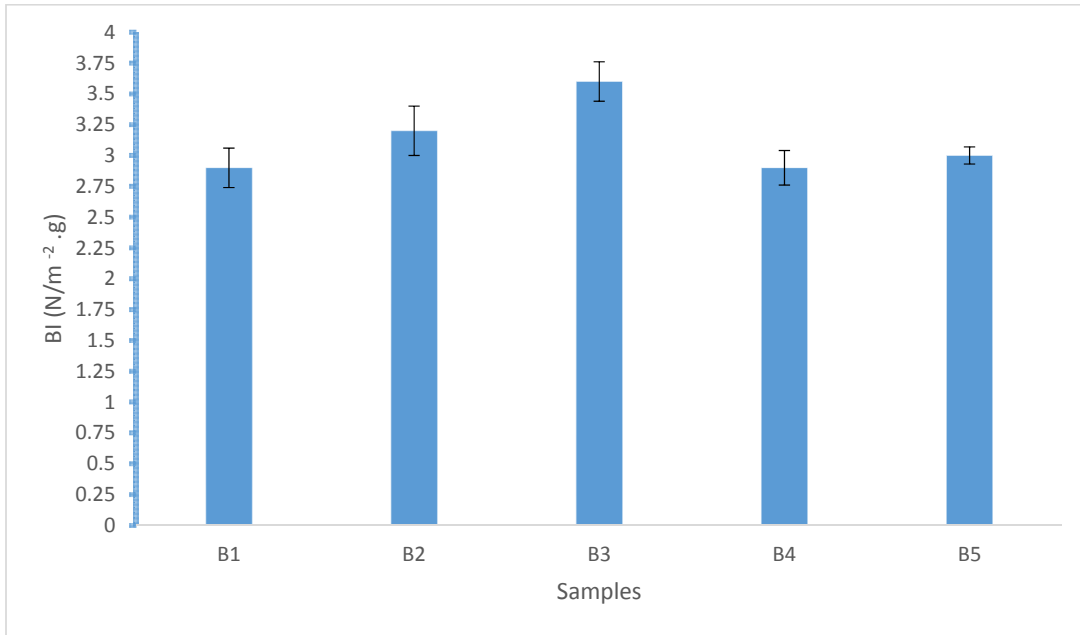
On the basis of the above equations, the following BI values were calculated for all the base samples (Table 4.4).

**Table 4.4** Bonding Index (BI) of developed base samples

Samples	Tensile Strength (N)		Area Density (g/m <sup>2</sup> )	Bonding Index N/m <sup>2</sup> .g
	MD	CD		
B1	313	157	159	2.9
B2	362	119	147	3.2
B3	371	169	150	3.6
B4	351	90	151	2.9
B5	328	96	140	3.0

The results presented in Table 4.4 show that the bonding index correlates well with the tensile strength of the fabric. Sample B3 had the highest tensile strength and BI values. Figure 4.15 shows that the tensile strength tend to increase as the bonding index increases. Wang (132) also found that by increasing the bonding index, the tensile strength of the fabric was increased. Therefore, it can be concluded that the blending ratio of the fibres affect the tensile strength of the fabric. Despite the fact that all the developed fabrics were prepared using the same process parameters, such as, sample B3 showed the highest bonding index that led toward higher tensile strength both in the machine and cross directions. This shows that sample B3 had the optimum blend of Tencel and bicomponent fibres, which resulted in the fabric with the optimum performance in terms of mechanical and aesthetical properties. The results also show

that any further increase in the bicomponent fibre content led to a decrease in both of these characteristics.



**Figure 4.15** Tensile strength of developed samples with respect to BI

#### 4.1.2.1 Tensile strength after thermal bonding process

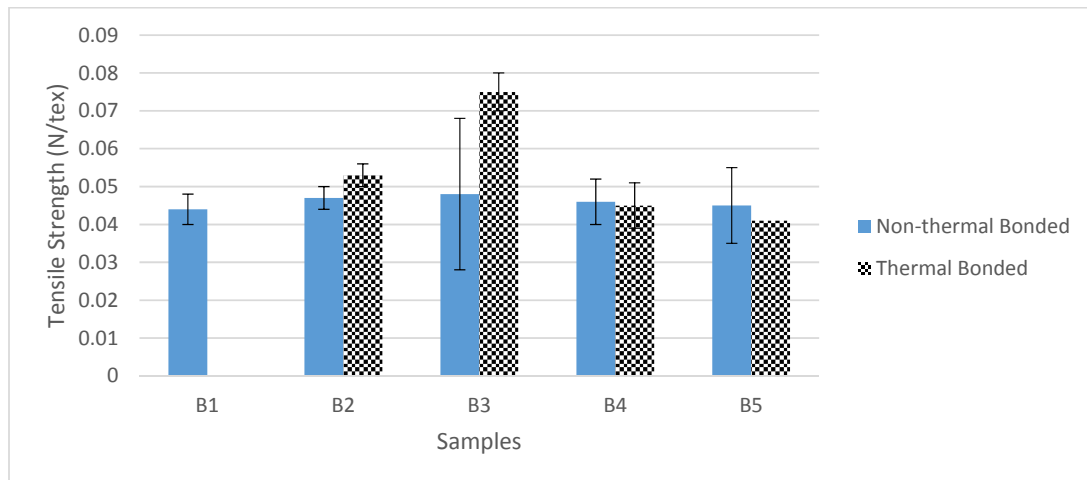
After the thermal bonding process, the thermoplastic bicomponent sheath/core fibres created bonding with their surrounding fibres. Under the controlled condition of the thermal bonding process, the intensity of the thermal bonding depends on the concentration of the bi-component fibres in the fabric structure. Many researchers have found that the mechanical properties of hydroentangled fabrics are very much related to the mechanical properties of fibres used and the intensity of the bonding (122). Figure 4.16 demonstrates that after the thermal bonding process, the tensile strength of the fabric was increased for samples B2 and B3 and then a fall in the tensile strength was observed for samples B4 and B5.

Sample B2 is based on 80% Tencel and 20% low melting bicomponent fibres. The results presented in Figure 4.16 show that after the thermal process tensile strength in the MD of B2 was 12.5% higher than sample B1 (100% Tencel). However, the breaking extension was slightly increased as shown in Figure 4.17. During the thermal process, crystallinity of the bicomponent fibres was changed as given in Table 4.3. For example the crystallinity of sample B2 was increased from 0.70% to 5.5% as result of

the thermal processing, which caused an incremental change in the tensile strength of the fabric in the MD.

Sample B3 showed even higher tensile strength than B2 after the thermal process, which is most likely due to the higher bicomponent fibres content of the fabric and the morphological changes that take place in the bicomponent fibres. As expected, the extensibility of the fabric (B3) in the MD was reduced (Figure 4.17) after thermal processing of the fabric, which is due to the presence of strong bonding between the fibres, which restricted the movement of the fibres in the fabric structure thus resulting in the lower value of breaking extension observed. However, any further increase in the bicomponent fibre content of the nonwoven fabric (samples B4 and B5) was detrimental to the tensile strength of the fabric after thermal processing, but these samples exhibited higher breaking extension values.

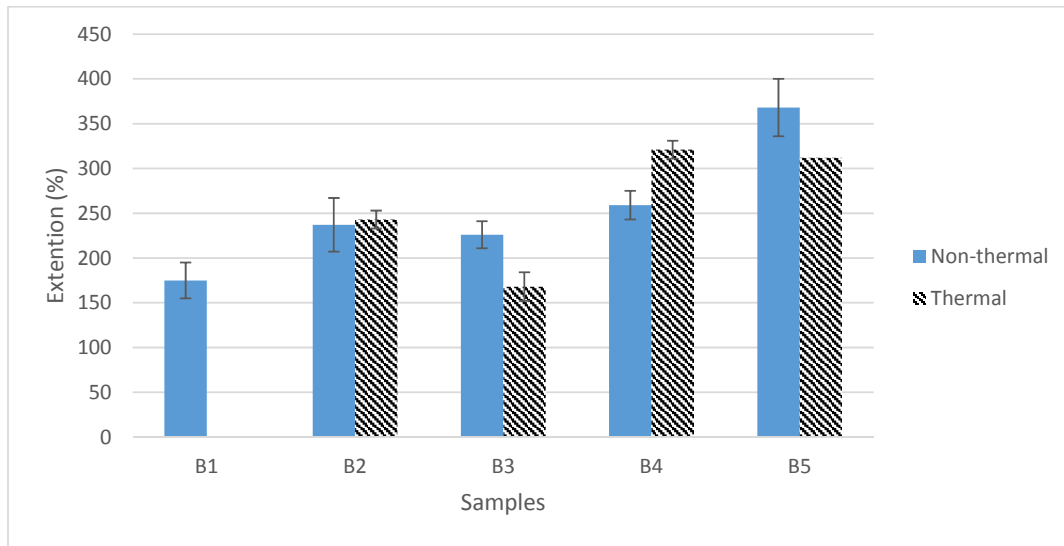
Wei et al (128) have reported that the tensile strength of a nonwoven fabric depends on the bonding temperature and the concentration of the binder fibres. Furthermore, the morphology of the fibre changes during the thermal process, which has a significant influence on the mechanical properties of the resultant fabric. These researchers have also concluded that the fibres with low orientation impart higher strength to the fabric during the thermal process as compared to the highly orientated fibres.



**Figure 4.16** Effect of thermal process on tensile strength of the samples in MD

Figure 4.17 also demonstrated that after thermal process, the extensibility of sample B5 was reduced because there were large amount of thromboplastic Bicomponent

fibres in the sample and after thermal process, because of thermal bonding Bicomponent fibres were unable to move.



**Figure 4.17** Effect of thermal process on breaking extension of samples in MD

## 4.2. Detailed study

### Selection of best sample for further investigation

On the basis of the above discussion it was concluded that sample B3 has the best overall performance as compared to the other samples in term of its flexure rigidity, aesthetical and tensile characteristics. Sample B3 showed lower flexural rigidity values, both in the machine and cross directions (Figure 4.5), and higher tensile properties as compared to other developed nonwoven samples. Higher concentration of the bicomponent fibres, as in sample B4 and B5, has detrimental effect on the thermophysiological and aesthetical properties of the resultant fabric. Thermal processing of the nonwoven fabrics with high thermoplastic fibre content can impart unwanted stiffness to the fabric, which can also have a negative effect on the permeability and absorbency of the fabric, since the wetting properties of the thermoplastic bicomponent fibres are very poor. Therefore, sample B3 formed the basis of the detailed study for the development of nonwoven fabrics for apparel applications. The results of the detailed study are discussed in the ensuing sections.

### 4.2.1. Dimensional properties

The dimensional properties of the fabrics studied include fabric thickness, fabric area density (FAD) and fabric bulk density (FBD). The dimensional properties of all fabric samples were determined according to BSI EN ISO 9073-2:1997.

#### 4.2.1.1 Thickness

The nonwoven fabric samples produced and used in this study are listed in Table 4.5. Samples S1 to S4 were produced by using the hybrid process (needlepunched and hydroentanglement) and sample S13 and S14 were produced using the hydroentanglement process from the lightly needle punched web for condensing the web. Samples E1 and W1 are the commercial nonwoven (Evolon) and woven fabrics, respectively. Thickness of a fabric can affect the smoothness of the fabric, appearance and ease in the finishing process. Thickness values of all the samples were measured at two different pressures (1gm/cm<sup>2</sup> and 5 gm/cm<sup>2</sup>) and five specimens of each sample were tested and the average values are given in Table 4.5. It was observed that there was very little variation in the thickness values obtained at these two different pressures.

**Table 4.5** Dimensional properties of nonwoven fabrics prepared

S#	Fabrics	Thickness (mm)		Area Density gm <sup>-2</sup>	Bulk Density gcm <sup>-3</sup>
		1 gmcm <sup>-2</sup>	5 gmcm <sup>-2</sup>		
	<b>Needlepunched/Hydroentangled (NP-HE)</b>				
	Needlepunched only				
S1	Sample produced @ 50 bars	0.72	0.70	117	0.167
S2	Sample produced @ 75 bars	0.44	0.43	111	0.258
S3	Sample produced @ 100 bars	0.48	0.45	125	0.277
S4	Sample produced @ 125 bars	0.46	0.45	120	0.266
	<b>Light needlepunched/Hydroentangled (LN-HE)</b>				
	Light needlepunched only				
S13	Sample produced @ 100 bars	1.00	0.99	150	0.151
S14	Sample produced @ 125 bars	0.88	0.86	150	0.174
E1	Evolon 80 PK	0.43	0.43	140	0.325
W1	Woven (1x1 Plain weave)	0.50	0.48	144	0.300

The results presented in Table 4.5 show the effect of water pressure on the thickness of the nonwoven fabric obtained. These results show that for the needlepunched/hydroentangled fabrics there was a marked decrease in the thickness value due to the initial increase in the water pressure from 50 bars to 75 bars.

However, any further increase in the water pressure had insignificant effect on the thickness of the nonwoven fabric obtained. This is most likely related to the fact the needlepunching process stabilises the web and when it is subsequently subjected to the hydroentanglement processes it is easily compressed at the lowest water pressure (50 bar) and any further increase in water pressure had little or no effect on the fabric thickness. Venu et al (133) have reported that with the increase in the hydro pressure, the thickness of the resulting fabric would be reduced because of the higher consolidation of the web.

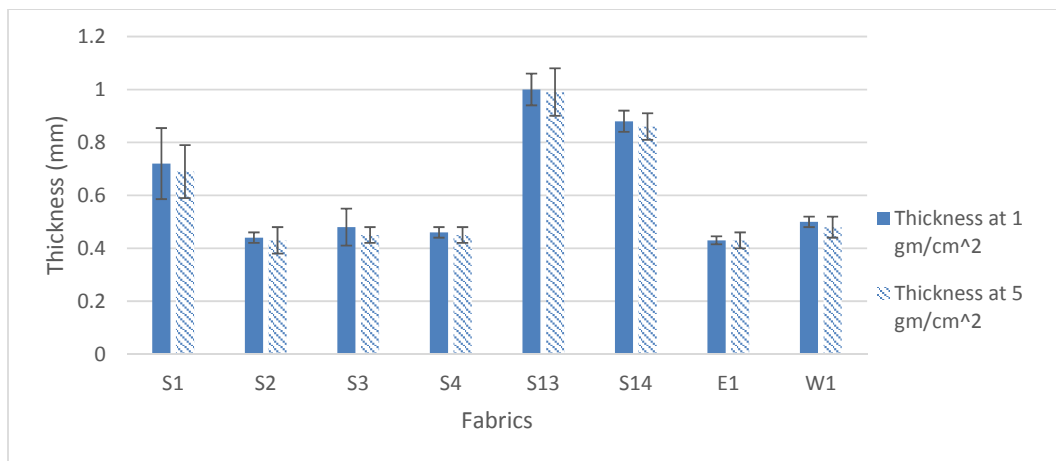
The results presented in Table 4.5 for the needlepunched-hydroentangled LN-HE fabric samples (S13 and S14) show that the thickness values of these fabrics were much higher than those obtained for the fabrics produced via the NP-HE process (samples S1-S4). Furthermore, for the LN-HE samples a gradual decrease in the thickness of the nonwoven fabric was observed as the water pressure was increase during the hydroentanglement process. Even at the highest water pressure the thickness of the LN-HE fabrics was higher than all of the NP-HE samples. This indicates that the needlepunching process results in the production of a compressed nonwoven structure that is more responsive to the applied water pressure during the hydroentanglement process.

It was noticed that after the needlepunching process the width of the feeding web increased. This was a consequence of the intensity of the needle board impact on the carded web. When the needle board hit the web, the fibres were scattered in different directions and the fibres in the inner part of the web were pushed towards the outside, thus increasing the width of the web after the needling process and therefore reduced the number of fibres per unit area of the resulting fabrics (samples S1-S4).

This may explain the lower thickness values for these fabric samples as compared to the fabrics prepared from the lightly needlepunched fabrics (samples S13 and S14). It was observed that the lightly-needled webs did not show any significantly increase in the web width after the needlepunching process due to the lower intensity of the needle board, which did not cause the fibres to move towards the outside of the web structure. Main effect of the pre-needling step was to consolidate (tuck) the web for better handling during hydroentanglement process. Since the fibres were not scattered during the pre-needling process and there were more fibres present per unit area of

the web, therefore, the resulting fabrics exhibited higher thickness values. Furthermore, any increase in the water jet pressure caused a decrease in the fabric thickness. Russell et al (56) have reported that the water jet pressure affects the thickness of the fabrics. They also observed that when the water jet pressure was increased it resulted in a decrease in the nonwoven fabric thickness.

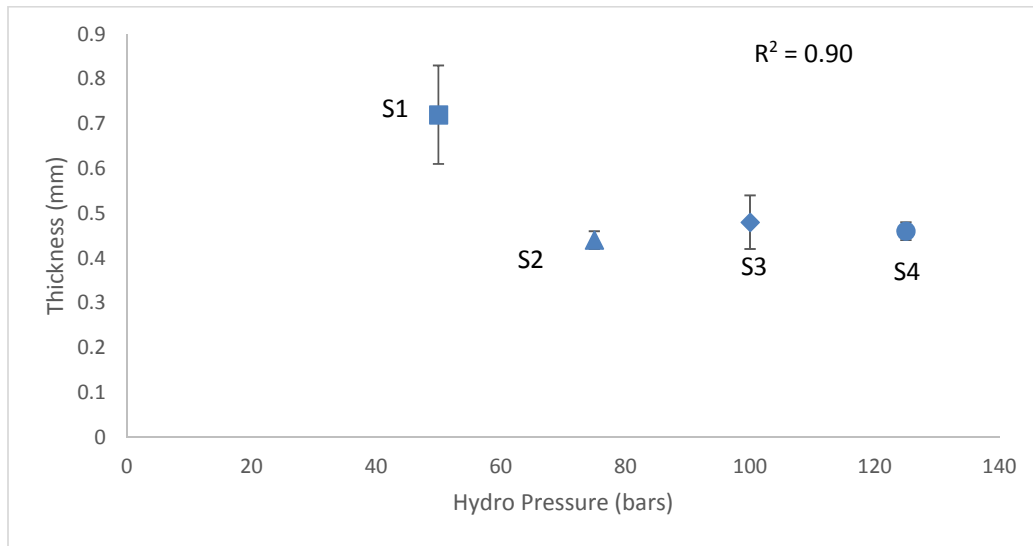
The thickness values of all the fabrics investigated in this study are given in Figure 4.18. The results show that the nonwoven fabric sample prepared by the pre-needling-hydroentanglement process (sample S13 and S14) exhibited the highest thickness values of all the fabrics. Samples S3 and S4, prepared by the hybrid needlepunching-hydroentanglement process, showed thickness values that were similar to the woven fabric sample W1, however, sample S13 and sample S14 had considerably higher thickness values than the woven and the commercial nonwoven fabric sample E1.



**Figure 4.18** Thickness of tested fabrics at 1gm/cm<sup>2</sup> and 5gm/cm<sup>2</sup>

Sample S2 and sample E1 had the lowest thickness values amongst all the fabric samples tested. This is mainly due to the nature of their structures. Sample E1 is the commercial nonwoven (Evolon) fabric that is made by using the spunlaying and hydroentanglement processes, which results in highly entangled and compact fabric structure. Pourdeyhimi and Minton (134) reported that higher energy level of water pressure results in a higher level of densification of the fibres in the web leading to a decrease in fabric thickness. Tausif and Russell concluded that the water jet pressure,

conveyor speed and nozzle diameter also affect the density of the hydroentangled fabrics (135).



**Figure 4.19** Relationship between water pressure and the thickness of the hydroentangled nonwoven fabrics prepared

Figure 4.19 demonstrated that water pressure effects on the thickness of the hydroentangled fabric and with increasing the hydro pressure the thickness decreased.

It was found that there were insignificant differences in thickness between the conventional woven fabric W1, commercial nonwoven fabrics E1 and the nonwoven fabrics samples 2 to 4 prepared in this study. From the nonwoven manufacturing process point of view, the fabric thickness is dependent on the applied pressure. Table 4.5 demonstrates that the thickness of the hydroentangled fabric was reduced when the water jet pressure in the hydroentanglement process was increased. Sample S1 produced at 50 bar was not fully consolidated as there was not enough energy at this pressure to entangle the fibres strongly within the fabric structure. But sample S4 produced at 125 bars hydro pressure exhibited lower thickness than sample S1.

The results clearly shows that that the hydro pressure has a strong impact on the thickness of the nonwoven fabric produced. Zheng et al (101) found that with the increase in the specific energy of the hydroentanglement process the fabric area



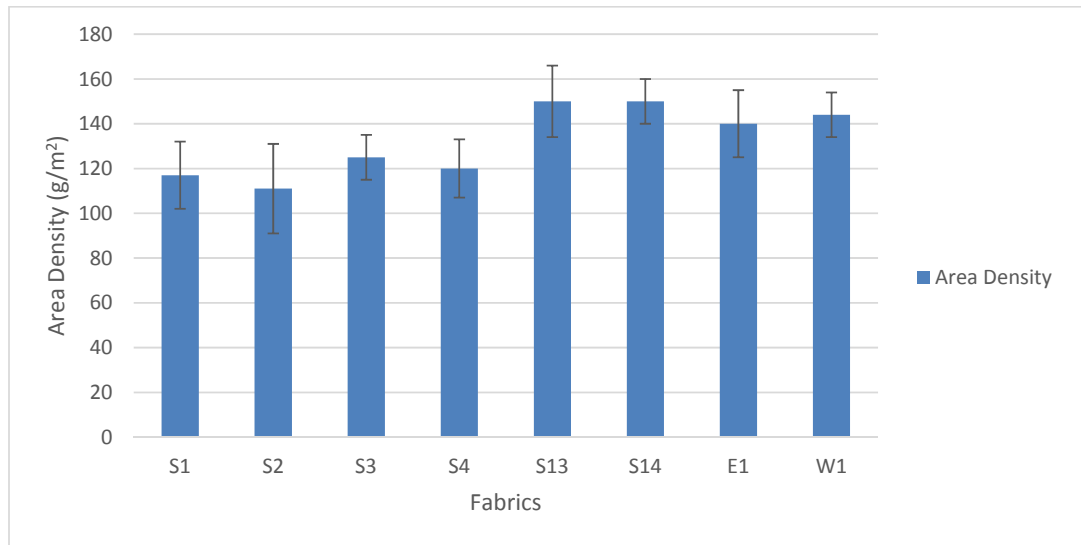
density decreased, mainly due to the fabric stretching caused by the enhanced impact of the water jets.

#### 4.2.1.2 Fabric area density

**Table 4.6** Details of Tested samples

S#	Sample	Process	Pressure (Bars)	Area Density (g/m <sup>2</sup> )
1	S1	Needlepunching and Hydroentanglement	50	117
2	S2	Needlepunching and Hydroentanglement	75	111
3	S3	Needlepunching and Hydroentanglement	100	125
4	S4	Needlepunching and Hydroentanglement	125	120
5	S13	Pre-needling and Hydroentanglement	100	150
6	S14	Pre-needling and Hydroentanglement	125	150
7	E1	Commercial Hydroentangled	-	140
8	W1	Woven	-	144

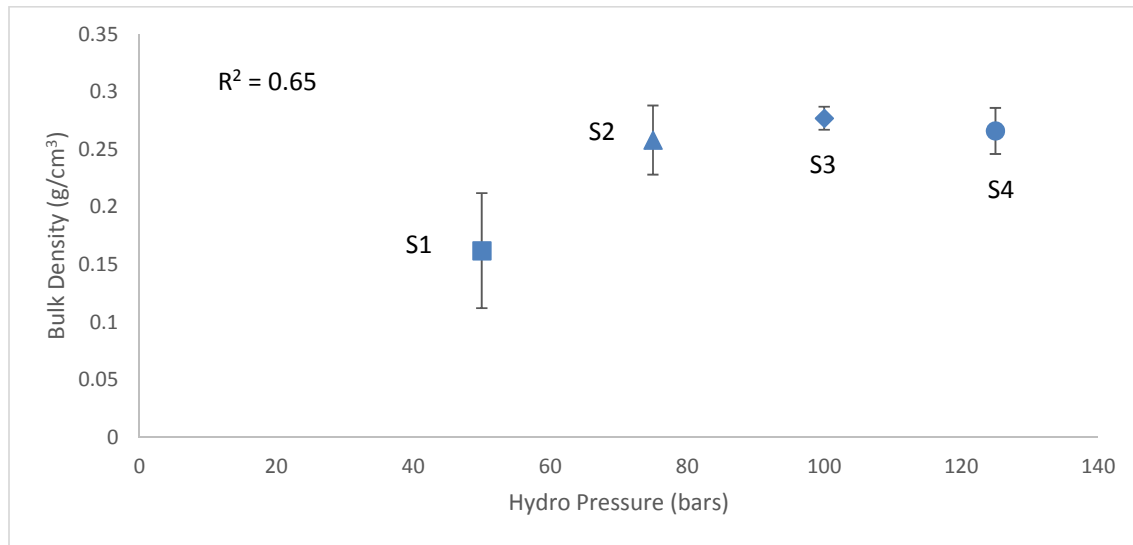
The fabric area density (FAD) values of all the fabric samples are presented in Table 4.6. These results show that the nonwoven fabrics produced by using the hybrid NP-HE process (samples S1-S4) showed much lower FAD values as compared with the other samples. This was mainly due to the impact of the needlepunching process. The higher FAD values for the nonwoven samples produced via the LN-HE process was due to the presence the higher number of fibres per unit area of the fabric as explained earlier. The FAD values for the nonwoven samples S13 and S14 were very similar to the woven W1 and the commercial nonwoven E1 fabrics investigated in this study. The graphical representation of fabric area density of the developed samples is shown in Figure 4.20.



**Figure 4.20** Area densities of nonwoven and woven fabrics

#### 4.2.1.3 Bulk density

The effect of water jet pressure on the fabric bulk density (FBD) is presented in Figure 4.21. The results show that in general the FBD values increase with an increase in the water jet pressure. However, there was significant sample to sample variation as illustrated by the error bars. The variation could possibly be due to the uneven nature of the carded web used for preparing the nonwoven fabric. The webs were produced by manual feeding to the carding machine and this can result in thick and thin places in the web structure, hence variation in the final nonwoven fabric obtained. Tausif and Russell (135) found that the process variables - such as jet pressure, conveyor speed and nozzle diameter – have a significant effect on the FAD and FBD values of the fabrics.



**Figure 4.21** Effect of jet pressure on bulk densities of the developed hydroentangled fabrics through hybrid process.

#### 4.2.2 Bending rigidity

Bending behaviour is an important factor, which affects the clothing properties such as handle and drape. Bending rigidity introduces the damping ability to the fabric and it affects the handling, deformation, crease resistance and buckling behaviour (62). The bending rigidity values of the tested fabrics in machine direction (MD) and cross direction (CD) were calculated by using equation 3.1 (chapter 3) and their arithmetic averages are presented in Figure 4.22. In total, 16 samples were investigated as listed in Table 4.7.

$$G = 0.1 M C^3 (\text{mg cm})$$

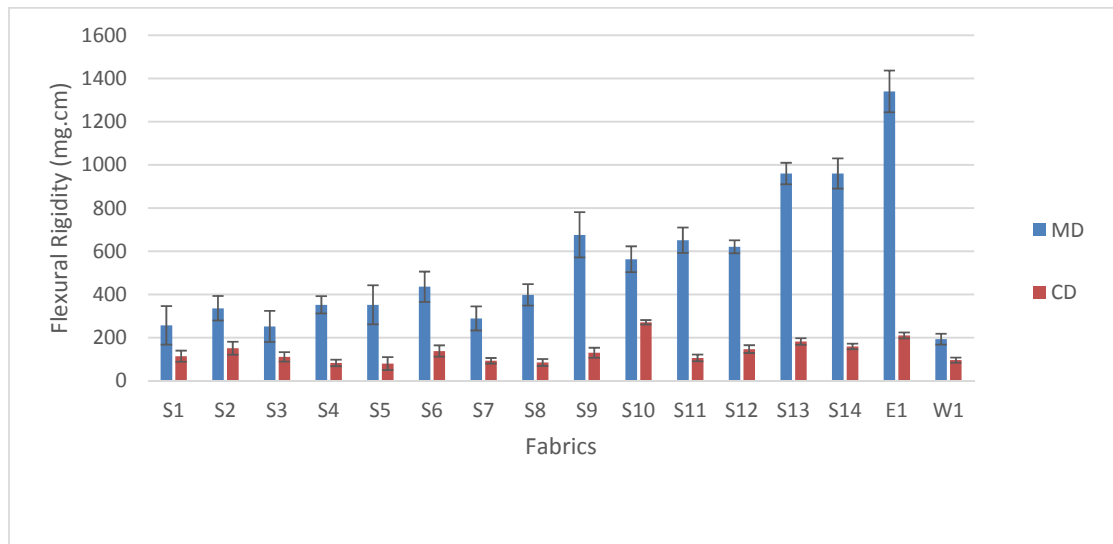
M= Fabric mass (mg/cm<sup>2</sup>)

C= Bending length (cm)

The results presented in Figure 4.22 show that the bending rigidity of the woven fabric W1 in the MD was lower than all the nonwoven samples, and only slightly higher in the CD than the nonwoven samples S4 and S5. The low bending rigidity of the woven fabric was due to the high degree of freedom of the individual fibres during bending. There were some other factors that supported the lower bending rigidity of the woven fabric, such as crimp, slippage of fibres, yarn flattening. According to Backer, properties of the yarn and the fabric structure also affect the fabric drape values (56).

Komori et al (137) worked on the behaviour of the fibres within the fabric structure through their model based on fibre contact theory. The main structural parameters used in their study were fibre orientation, fibre crimp and elasticity of the fibre. These researchers concluded that the arrangement of the fibres in the fabric structure has a major influence on the mechanical properties of a fabric.

The formation of hydroentangled fabrics from the web is comprised of complex fibre-fluid interactions such as: (1) compression of the web under jet pressure, (2) reorientation of the fibres (103). Compression of the web directly relates to the thickness or intensity of the entanglement of the fibres that has a direct influence on the flexural rigidity of the fabrics. The orientation of the fibres also affect the flexural rigidity of the fabric, since more oriented fibres result in better flexural rigidity of the fabric. Random variation due to the non-uniformities in the laydown process increases the bending stiffness of the fabric (123). Ghane et al (124) observed that higher degree of entanglement within the fabric enhanced the bending properties of the fabric produced.



**Figure 4.22** Bending behaviour of developed nonwoven, commercial nonwoven and woven fabrics

Hydroentangled nonwoven fabrics produced from the hybrid (NP-HE) process showed lower bending values than the fabric produced from pre-needling and hydroentanglement process as shown in Table4.7 and Figure 4.22. This appears to be due to the lower number of fibres per unit area in the fabric obtained from the NP-

HE process. Figure 4.22 demonstrates that the bending rigidities in the CD of all samples were lower than the bending rigidities in the MD. This was because of the greater fibre-fibre interaction in the MD.

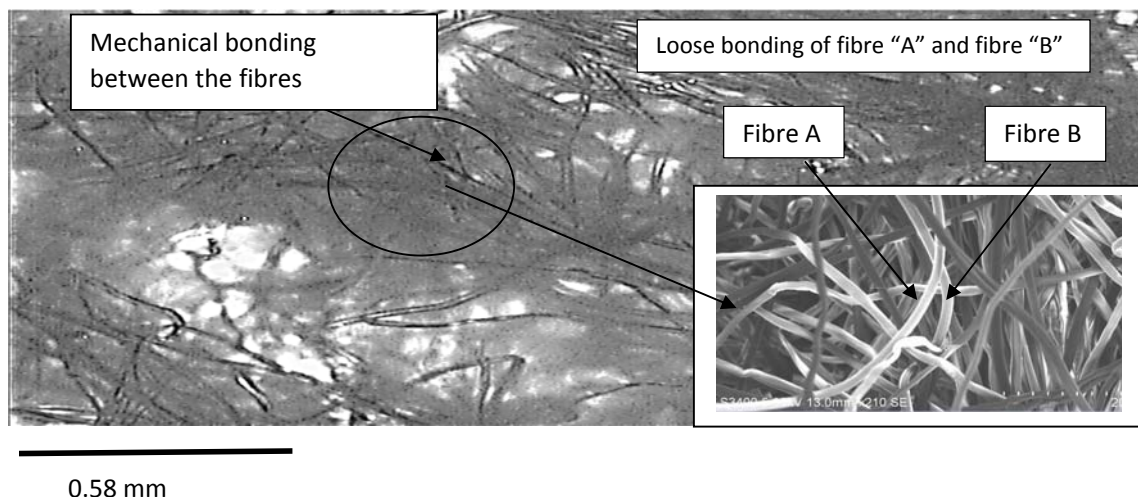
In the CD, the bonding between the fibres was not as intense entangled as in the MD due to which there were more spaces between the fibres in CD than in the MD. The fibre to fibre bonding in the MD was stronger due to the enhanced fibre entanglement, since parallel laid webs were used for the production of the nonwoven fabrics and there were fewer spaces between the fibres, which restricted the fibre movement in the MD.

**Table 4.7** Bending rigidity values of fabrics studied

S#	Fabrics	Bending Rigidity (mg.cm)			
		MD	SD. values	CD	SD. values
	<b>Needlepunched-Hydroentangled</b>				
S1	Sample produced @ 50 bars	257	89	114	26
S2	Sample produced @ 75 bars	336	57	151	30
S3	Sample produced @ 100 bars	352	72	111	22
S4	Sample produced @ 125 bars	352	40	83	15
	<b>Thermal Bonded</b>				
S5	Sample produced @ 50 bars	352	90	80	30
S6	Sample produced @ 75 bars	436	70	138	26
S7	Sample produced @ 100 bars	389	56	93	13
S8	Sample produced @ 125 bars	398	50	85	16
	<b>Calendared</b>				
S9	Sample produced @ 50 bars	676	105	130	23
S10	Sample produced @ 75 bars	563	60	271	10
S11	Sample produced @ 100 bars	651	59	106	16
S12	Sample produced @ 125 bars	621	30	147	18
	<b>Pre-needled-Hydroentangled</b>				
S13	Sample produced @ 100 bars	960	50	182	15
S14	Sample produced @ 125 bars	960	70	159	13
E1	Evolon 80 PK	1340	97	210	14
W1	Woven (1x1 Plain weave)	193	25	96	12

#### 4.2.2.1 Bending rigidity of samples prepared by the hybrid process (needle punching and hydroentanglement process)

Figure 4.22 shows the bending rigidity values of the various developmental and commercial fabrics investigated in this study. Samples from S1 to S4 showed lower flexural rigidity than thermal and calendared samples. The first reason of lower flexural rigidity was the structure of the samples. During needling process, the fabric was stretched that effects on the fabric physical structure in term of fibre orientation and number of fibres in per unit area of the fabric. Same trend was found by Midha et al (98), who reported that needle penetration affects the mechanical properties of the fabrics, because with needling process the fabric stretches and the tensile strength and flexural rigidity of the fabric are reduced. Secondly, the intensity of the entanglement hydro process also has an impact on the flexural rigidity of the samples S1 to S4. Light entanglement at low pressure gave lower flexural rigidity (sample S1) and intense entanglement at higher pressure gave higher flexural rigidity (S4) in the MD. Figure 4.23 is a microscopic view of S2 samples, which shows the presence of porous structure and the fibres are loosely entangled.

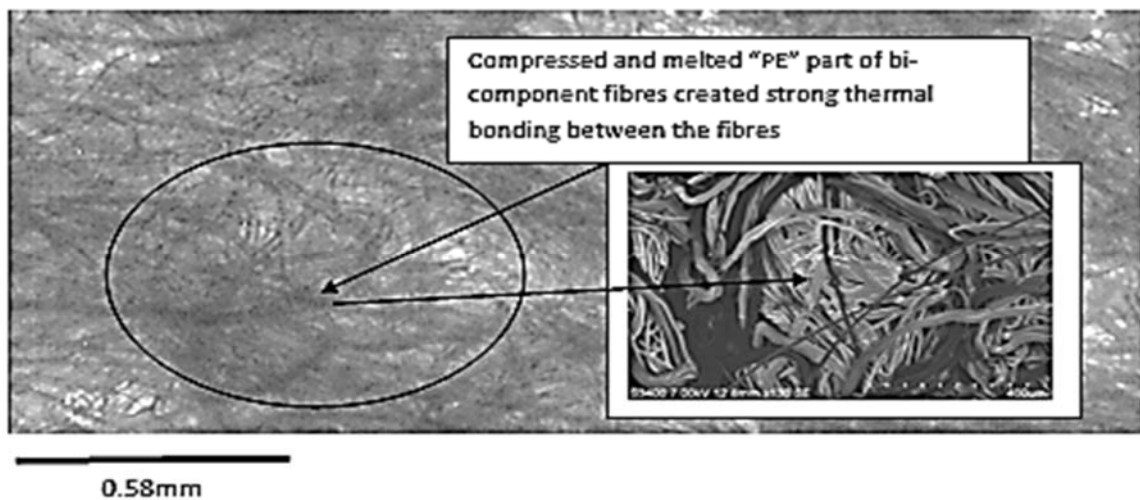


**Figure 4.23** Needlepunched and hydroentangled nonwoven fabrics produced at 75 bar showing mechanical bonding behaviour of fibres

However, after the thermal bonding process the flexural rigidity values of all the samples were increased (37% for S1, 30% for S2, 15% for S3 and 13% for S4 in MD. It can be seen in Table 4.7 that first two samples, S1 and S2, showed the higher increase in the flexural rigidity than samples S3 and S4 in the MD. Samples S1 and

S2 were loosely entangled because of the lower hydro pressure used. Furthermore, during thermal process the fibres were easily melted and created strong thermal bonding that restricted movement of the fibres, on the other hand samples S3 and S4 were tightly entangled and therefore during the thermal process the melting of the bicomponent fibres were not easily melted and did not form strong bonding with the neighbouring fibres.

During the calendaring process, because of heat and pressure, the sheath part of bicomponent fibres (PE) was melted and penetrated into the fabric region due to the high pressure of the hot rollers (1T) and created thermal bonding between the fibres as shown in Figure 4.24. The calendaring process causes higher stiffening of the fabric and results in the higher bending rigidity of the fabric as compared to the combination of infrared thermal bonding and the hydroentanglement process (hybrid system). After calendaring, sample S9 had bending rigidity value of 676 mg.cm in MD, which is 163% higher than sample S1. However, sample S9 showed 15% higher flexural rigidity in CD than S1 due to the presence of less number of fibres in the cross direction region of the fabric. Desai, et al (131) have reported that some factors such as temperature, pressure, nip contact and processing speed play a pivotal role in the calendaring process. In the work carried out in this research, 100% contact rollers were used due to which the fabric obtained after the calendaring process were significantly stiffer those obtained via the thermal bonding process.

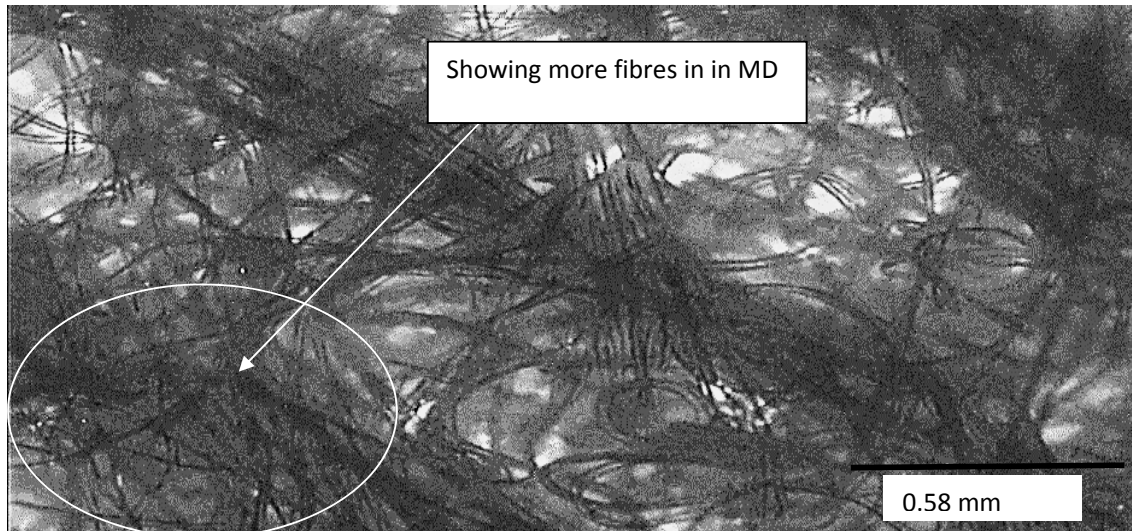


**Figure 4.24** Calendared thermal bonding between the fibres

Bahari et al (138) have stated that the flexural rigidity of nonwoven fabrics is influenced by the fibre properties and fibre orientation within the structure. They also found the flexural rigidity depends on the independent movement of the fibres in the fabric structure.

#### 4.2.2.2 Bending rigidity of samples prepared through pre-needling and hydroentanglement process.

The results illustrated in Figure 4.22 clearly show that the samples (S13 and S14) produced through pre-needling/hydroentanglement process, exhibited higher bending rigidity (BR) than the samples produced from the hybrid needling/hydroentanglement process. There are two main reasons for this; firstly, the fabric produced through the pre-needling and hydroentanglement process exhibited higher fabric weight since in the absence of intense needling the fibres were not dispersed and more fibres were present per unit area of the fabric that allowed limited space for fibre movement to occur in the fabric region, which led to the higher BR in the MD than the samples produced by using the hybrid needling/hydroentanglement process.



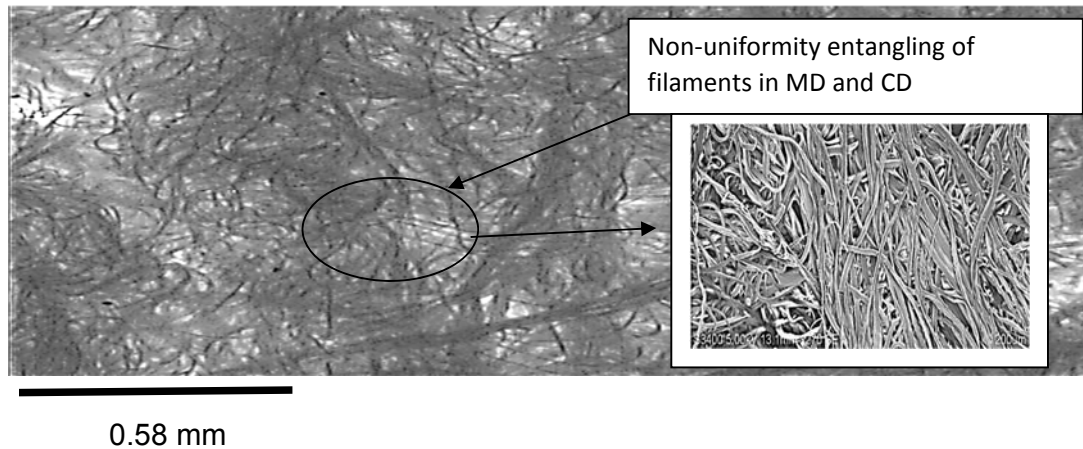
**Figure 4.25** Pre-needled and hydroentangled nonwoven fabric produced at 100 bar hydro pressure showing mechanical bonding between the fibres.

Secondly, more fibres present in the MD caused greater entanglement of the fibres present in the CD, which caused further restriction in the movement of the fibres and thus resulted in the higher BR values for S13 and S14, both in the MD and CD.



#### 4.2.2.3 Bending rigidity of the commercial nonwoven and woven fabric

Commercial nonwoven fabric E1 showed somewhat higher BR than all other nonwoven and woven samples in MD. There were two main reasons for this, firstly, the structure of the fibres used and secondly, the manufacturing technique employed for the production of the fabric. Commercial nonwoven fabric was made by using the bicomponent island-in-the-sea filaments via the spunlaid and hydroentanglement processes. These fibrils were very fine and endless as compared to the Tencel and the sheath core bicomponent fibres used for the preparation of nonwoven samples in this study. Because of the spunlaid process, the fibres created strong bonds with their surrounding fibres before the hydroentanglement process and then after the hydroentanglement process the bonds between the fibres were further strengthened because of the entanglements of the fractured fibrils within the fabric structure.



**Figure 4.26** Bonding behaviour of filaments in commercial hydroentangled nonwoven fabric

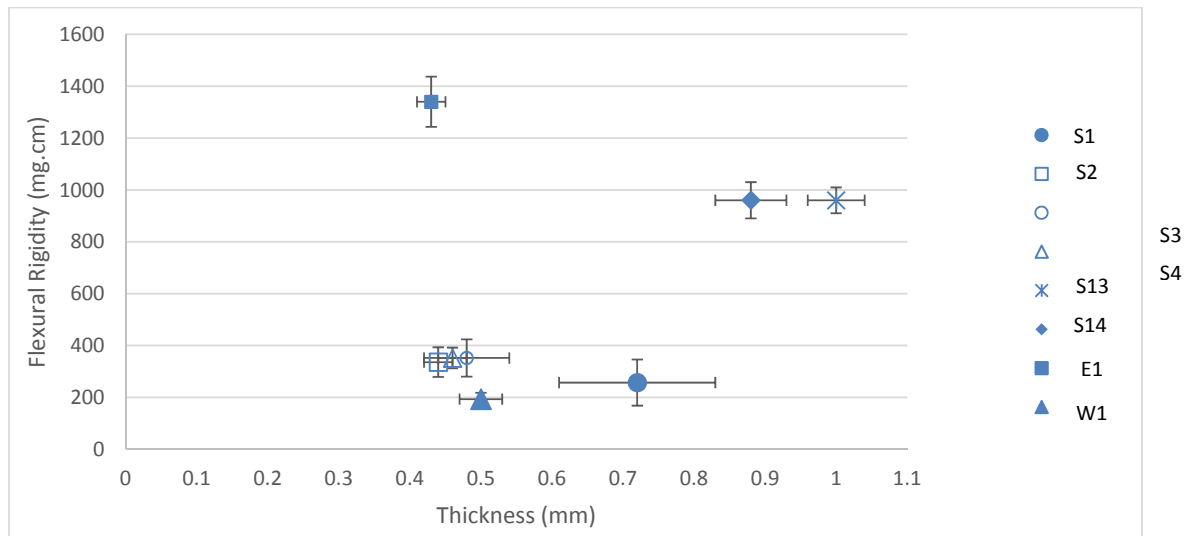
In addition, due to the fibril structure, there were no spaces available for the fibre movement to occur in MD, which resulted in the higher BR (1340 mg.cm) observed in the MD and a much lower BR value (210 mg.cm) in the CD.

Woven sample (W1) showed lower BR in both the MD and CD than the nonwoven samples, as it has been explained earlier that the low bending rigidity of the woven fabric was due to the high degree of freedom of individual fibre motion during bending, the crimped nature and slippage of the fibres.

The nearest value of BR of nonwoven fabric sample to the woven sample was S3, which exhibited 352mgcm in the MD and 111 mg.cm in the CD and woven sample W1 exhibited values of 193 mg.cm and 96 mg.cm in the MD and CD, respectively, as shown in Figure 4.22 There were other nonwoven samples such as S4 and S7 that exhibited higher BR in the MD but lower BR in the CD as compared to the woven sample W1.

#### 4.2.2.4 Effect of thickness on the bending rigidity of the fabrics

Figure 4.27 shows a plot of thickness vs. bending rigidities. It shows that there is no real relationship between the thickness and the bending rigidities of the tested fabrics. Such as the fabric S1 produced at 50 bars hydro pressure exhibited 257 mg.cm BR with thickness of 0.72 mm, however, when the pressure was increased to 75 bars the fabric S2 exhibited BR of 336 mg.cm with reduced thickness (0.44 mm), as shown in Figure 4.27. Fabric S3 produced at 100 bar hydro pressure exhibited BR value of 352 mg.cm with thickness of 0.48 mm. The nonwoven fabric S4 produced at 125 bars hydro pressure also exhibited higher BR with lower thickness than the fabric samples S1 and S2 produced at 50 and 75 bars hydro pressure respectively. So, it can be conclude here that the flexural rigidity mainly depends on the fibre's independence movement in the fabric structure that was also found by K. Smith et al (127), who found that if fibres are acting independently in the fabric structure they caused lower fabric flexural rigidity.



**Figure 4.27** Effect of fabric thickness on the BR in MD of tested fabrics.

Furthermore, the nonwoven fabric sample S13 produced at 100 bar hydro pressure (with pre-needling) exhibited BR value of 960 mg.cm with 1 mm thickness. This appears to be the result of higher GSM of the fabric that was 150 g/m<sup>2</sup> and the fabric sample S3 produced at 100 bar hydro pressure (with needling process) showed lower fabric area density (125 g/m<sup>2</sup>) that can be seen in Figure 4.27.

Commercial nonwoven hydroentangled fabric E1 showed higher BR value than all other nonwoven samples with lower thickness value. The BR and thickness values of the commercial nonwoven hydroentangled fabric E1 were 1340 mg.cm and 0.43 mm, respectively. As it has been discussed above that commercial nonwoven was made by micro island in the sea filaments and these filaments were first spun laid and then bonded by hydroentangled for getting better integrity within the structure of the fabric.

It can be seen in the Figure 4.26 that there are no uniformity in fibres in any directions and that was one reason of increasing the BR of the commercial nonwoven hydroentangled fabric in machine and cross directions.

The woven fabric W1 exhibited the lowest BR value of all the tested samples and the BR in MD and thickness values of the woven fabric were 193 mg.cm with 0.50 mm, respectively.

It may be concluded that thickness did not have any significant influence on the bending rigidity of the fabric and there were some other factors, such as bonding techniques and fabric weight (GSM), that directly affect the bending rigidity of the fabric.

**Table 4.8** Details of fabric thickness versus bending rigidities of tested fabrics

S#	Fabrics	BR (MD)	(Thickness) 1 gm/cm <sup>2</sup>
		mg.cm	mm
	<b>Hydroentangled (Needled Punched)</b>	Y	X
S1	Sample produced @ 50 bars	257	0.72
S2	Sample produced @ 75 bars	336	0.44
S3	Sample produced @ 100 bars	352	0.48
S4	Sample produced @ 125 bars	352	0.46
	<b>Hydroentangled ( Light needle punched)</b>		
S13	Sample produced @ 100 bars	960	0.88
S14	Sample produced @ 125 bars	960	0.86
E1	Evolon	1340	0.43
W1	Woven (1x1 Plain weave)	193	0.50

The thickness of the fabric also affects the rigidity of the fabric. Thicker fabrics resist the bending behaviour of the fabric than thinner fabric (124). Because in thicker fabric more fibres are condensed in per unit area of the fabric ( $\text{g/m}^2$ ) and fibre cannot freely moves in its region that affect the flexural rigidity of the fabric. Mehmet, Thomas et al, also found (139) that, the density of the material, the bending modulus and the thickness affect the stiffness of the fabric. As it can be seen in Table 4.8 that, S1 to S4 showed lower bending rigidity than S13 and S14. It was because S1 to S4 samples were prepared through hybrid process (needle punched and hydroentanglement) that reduced the number of fibres in per unit area of the fabric and also reduced the thickness of the fabric. Second, Samples S13 and S14 were prepared only through hydro and pre-needled process that enhanced the thickness and number of fibres in per unit area of the fabric, due to which S13 and S14 showed higher bending rigidity.

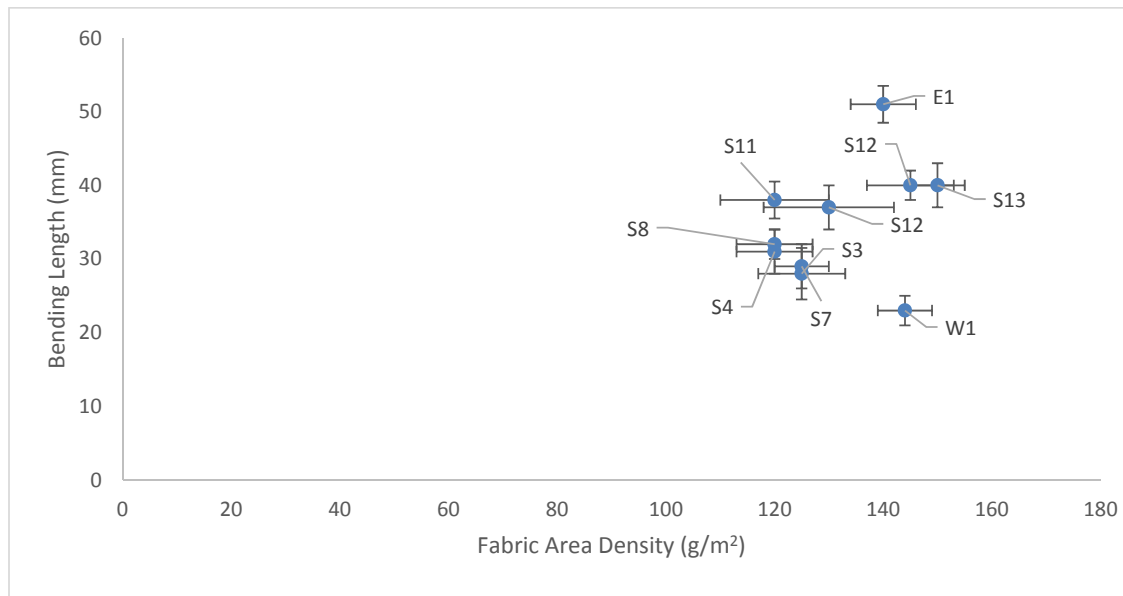
#### 4.2.2.5 Effect of area density on the bending length of the fabrics

Figure 4.28 demonstrated that the fabric weight (GSM) directly effects on the bending length of the nonwoven fabric. Fabric S3 produced at 100 bars hydro pressure with needle punched process possessed  $125 \text{ g/m}^2$  exhibited 28mm bending length, but

when pressure was increased from 100 bars to 125 bars then the fabric S4 weight was reduced to 120 g/m<sup>2</sup> from 125 g/m<sup>2</sup>. This reduction in fabric weight increased the bending length to a value of 31.3 mm, as shown in Figure 4.28. This means at higher pressure, the fibres were more intensively entangled that restricted the fibres movement in the fabric region due to which it showed higher bending length in MD.

Hydroentangled nonwoven fabric exhibited almost the same bending length before and after the thermal process as shown in Table 4.9. Such as, the fabric S3 produced at 100 bar hydro pressure exhibited 28mm bending length, which is similar to the bending length of fabric sample S7 that was 29.3 mm, after it was subjected to the thermal process. Similar bending length value was obtained for the fabric sample S4 and S8 produced at 125 bars pressure.

The fabric sample S11 produced at 100 bars hydro pressure with needled process exhibited nearly 38% higher bending length after it was passed through the calendaring process as shown in Figure 4.28. It was because of creation of strong bonding between the fibres within region of the fabric after the calendaring. The strong bonds provided resistance to bending during the bending motion of the fibre and resulted in higher bending length value.



**Figure 4.28** Effect of area densities on the bending length of tested fabrics

The fabric sample S13 produced at 100 bars hydro pressure with pre-needling process exhibited higher bending length (40 mm) with 150 g/m<sup>2</sup> area density. It may be proposed that the bending length for the fabrics produced using the hydroentanglement and pre-needling process has somewhat direct relationship with the fabric area density i.e. the bending length increase with an increase in the fabric area density of the nonwoven fabric. This was a consequence of the presence of greater number of fibres per unit area of the fabric in the heavier fabric, which resisted the fibre motion during bending and caused the higher bending length value.

The bending length for Evolon E1 was 51.3 mm was the highest value obtained for all the nonwoven and woven fabric samples tested. The area density for the Evolon fabric was 140 g/m<sup>2</sup> fabric weight that is significantly higher than all the nonwoven fabrics produced via the hybrid process, but lower than the nonwoven fabrics that were produced using the pre-needling and hydroentanglement process.

It is observed that the Evolon fabric E1 exhibited higher bending length with lower fabric area density as compared to the fabrics S13 and S14 produced from the pre-needling and hydroentanglement process that exhibited bending length of 40mm with higher fabric area density (150 g/m<sup>2</sup>). This was due to the combined effect of fibre types and bonding processes used in the production of these fabrics. The Evolon E1 was produced using the spunlaying and hydroentanglement processes where continuous filaments were used, resulting in very strong bonding. The nonwoven fabrics produced in this study were prepared in the laboratory using staple fibres and the bonded was carried out by means of the hydroentanglement process only.

Woven fabric W1 of area density of 144 g/m<sup>2</sup> exhibited lower bending length that was 23 mm, as compared to all other nonwoven samples. The fabric area density of the woven fabric W1 was higher than all the nonwoven samples, with exception of the sample produced through the hydroentanglement and pre-needle process. On the basis of fabric area density alone, the bending length of the woven fabric is expected to be higher than most of the nonwoven samples, as discussed earlier. However, the lower value of bending length obtained for the woven fabric is due to some other factors such as crimp, yarn buckling and the alignment of fibres in the fabric structure.

The higher GSM was because of yarns magnitude in the fabric instead of fibres. This mean during weaving process all yarns are same in per unit area of the fabric in whole

process but on the other hand during hydroentanglement process the fibres are dispersed in different direction that leads to reduce the fibres magnitude in per unit of the nonwoven fabric.

**Table 4.9** Bending length and fabric weight (g/m<sup>2</sup>) of tested fabrics

S#	Fabrics	Bending Length (mm)	Fabric weight (gm <sup>-2</sup> )
		MD	
	Hydroentangled (Needled Punched)		
	<b>Hydroentangled</b>		
S3	Sample produced @ 100 bars	28	125
S4	Sample produced @ 125 bars	31.3	120
	<b>Thermal Bonding</b>		
S7	Sample produced @ 100 bars	29.3	125
S8	Sample produced @ 125 bars	32.6	120
	<b>Calendaring</b>		
S11	Sample produced @ 100 bars	38.4	125
S12	Sample produced @ 125 bars	37.8	120
	Hydroentangled (Light needle punched)		
S13	Sample produced @ 100 bars	40	150
S14	Sample produced @ 125 bars	40	150
E1	Evolon 80 PK	51.3	140
W1	Woven (1x1 Plain weave)	23	144

It has been shown from the correlation of coefficient that there is a moderate relationship between the fabric weight (GSM) and the bending length of the nonwoven fabric. The correlation of coefficient was calculated based on the values given in Table 4.9. The correlation “r” was calculated by using following formula:

$$r = \frac{\sum ZxZy}{n-1}$$

Where,

Zx : Standardised vales of “X” (Area Density).

Zy : Standardised values of “Y” (Bending Length).

n : No. of values.

The correlation coefficient ( $r$ ) was calculated to be 0.60, which suggest that there is a good relationship between the bending length and fabric area density.

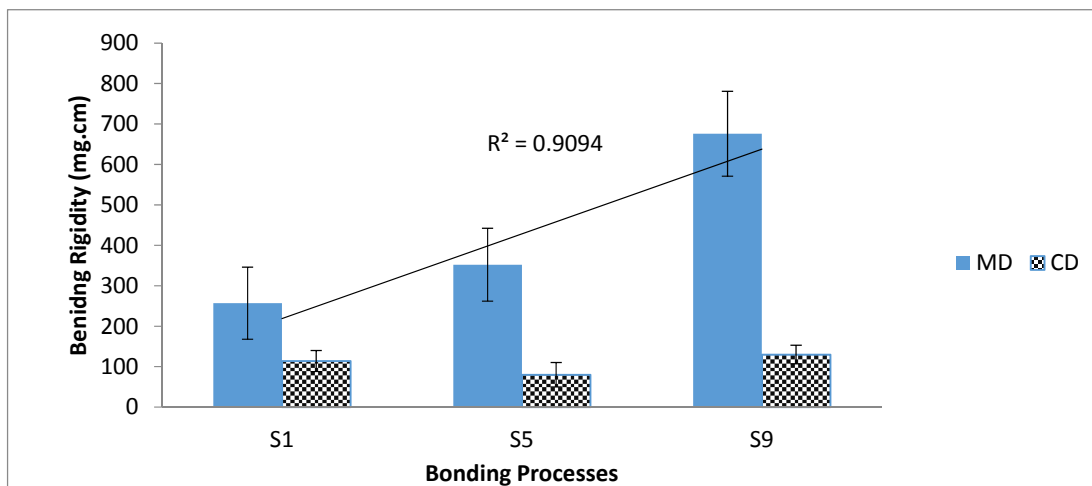
#### 4.2.3 Effect of hydro pressures on flexural rigidity of nonwoven fabrics (Hybrid process)

The results show that the bending rigidities of the nonwoven samples changed with changing of the hydro pressure or specific energy of the hydroentanglement process, as discussed in the following sections.

##### 4.2.3.1 Fabric produced at 50 bars hydro pressure

The flexural rigidity of the hydroentangled sample S1 produced at 50 bar hydro pressure was determined and the results are presented in Figure 4.29. The relatively low values in MD and CD (250 mg.cm and 100 mg.cm) were obtained due to the low bonding forces between the fibres in the region of the fabric. There appear to be two main reasons for the low flexural rigidity observed:

1. Lose entanglement of the fibres
2. Large spaces between the fibres per unit area of the fabric.

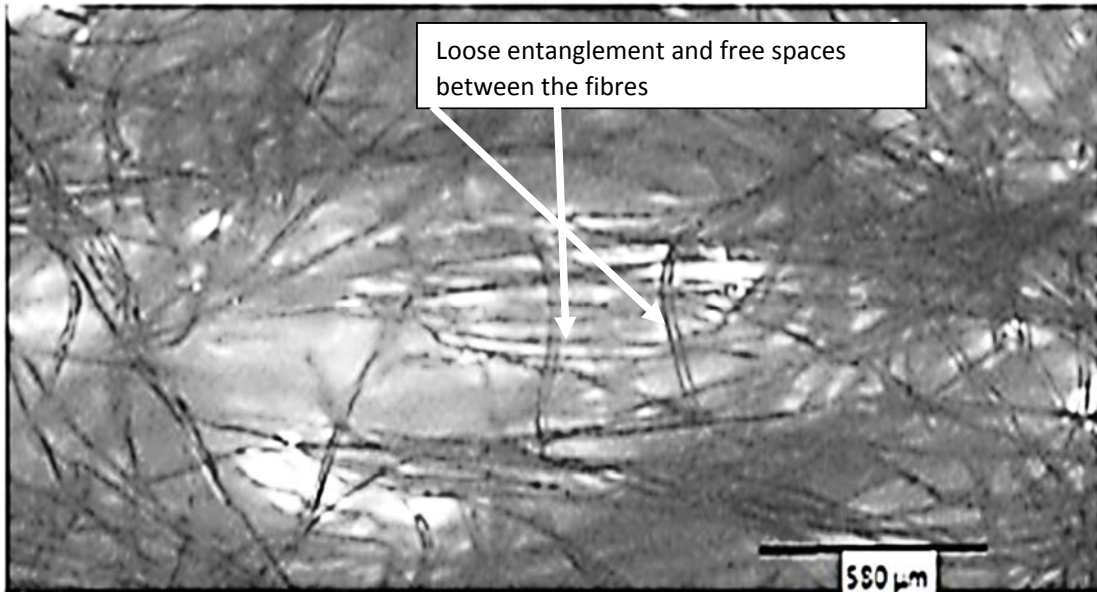


**Figure 4.29** Bending behaviour of nonwoven fabric produced at 50 bars pressure.

As, it has been discussed erlier that many researcher found that flexural rigidity depends on the intensity of the entanglement and freedom of fibres. The intensity of the 50 bar pressure was not sufficient to tightly bond the fibres within the fabric structure and this allowed the fabric to bend with ease thus resulting in low flexural



rigidity values for the fabric sample. Secondly, the fibres were adequately dispersed and the structure was too loose, which provide freedom of motion to the fibres in any direction. Figure 4.30 is a microscopic image of the sample produced at 50 bars hydro pressure, which clearly shows these two characteristics of the fabric .



**Figure 4.30** Microscopic view of the sample produced at 50 bar hydro pressure.

The flexural rigidity of thermal bonded sample was higher than the samples hydroentangled in MD and was lower in CD. During thermal bonding, the low melting PE sheath part of bicomponent fibres melted and created thermal bonding with other surrounding fibres, particularly in the MD thus restricting the fibre movement in MD and resulting in the higher flexural rigidity observed. Loose

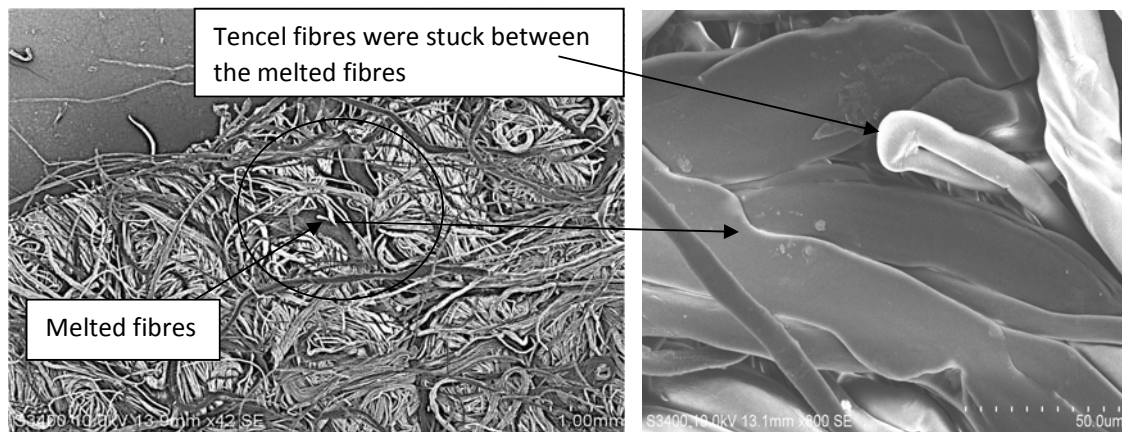
However, in the CD the fibres were not entangled as closely as in MD due to which there were very limited thermal bonding between the fibres and that allowed more fibre movement, resulting in lower value of the flexural rigidity in CD as shown in Figure 4.29. On the other hand, the calendaring of the sample resulted in a considerable increase in the flexural rigidity value of the sample in the MD and a small increase in the CD, as shown in Figure 4.29. This was due to the high thermal bonding created between the fibres because of the heated pressure rollers. When sample passed through the calendaring process, the heated (120° C) pressure rollers pressed the

fibres and melted region of the fibres were bonded together and restricted their movement in the MD and the sample also exhibited harsh surface appearance.

#### 4.2.3.2 Fabric produced at 75 bar hydro pressure

The samples produced at 75 bar hydro pressure exhibited higher flexural rigidity as compared to the samples produced at 50 bar hydro pressure. At this pressure level, the fibres were entangled slightly closely and had greater bonding forces between the fibres as compared with the fabric produced at 50 bar hydro pressure. The fibres were also rearranged in the MD and intensively entangled that restricted the fibre movement in this direction, therefore higher flexural rigidity was achieved in MD and due to the higher pressure intensity the fibres were better dispersed and compacted resulting in higher flexural rigidity values for the sample in both direction as compared to the fabric produced at 50 bars pressure.

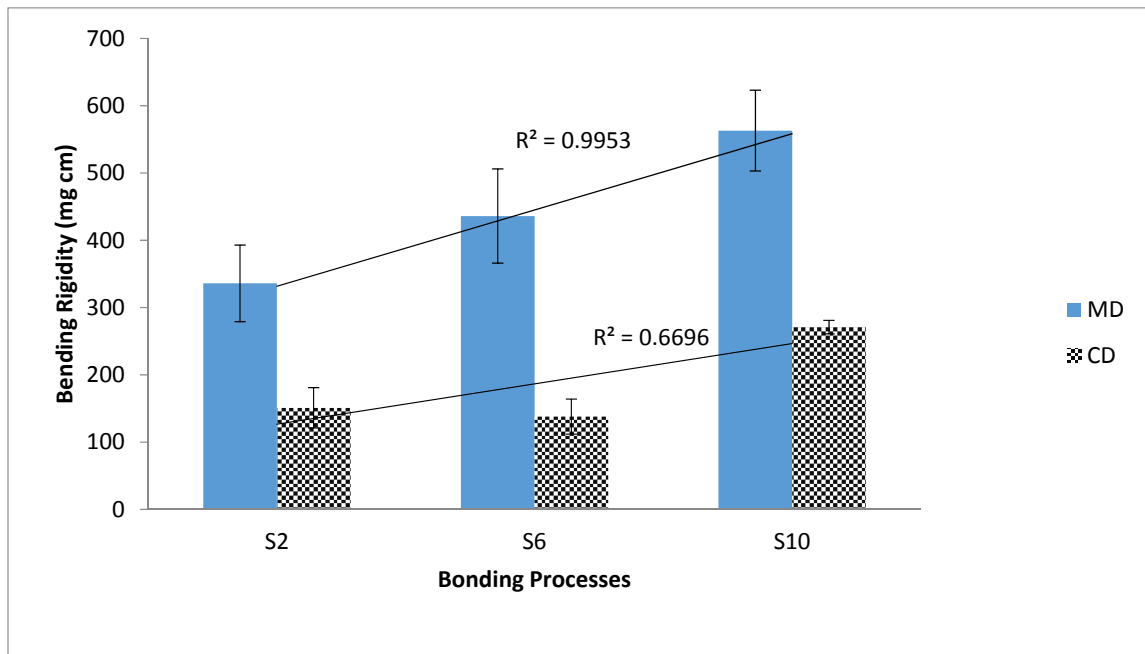
The thermal bonding process also had a significant effect on the flexural rigidity of the fabric produced because the fibres were very closely entangled so the melted PE sheath part of the bicomponent fibres created strong bonding with the neighbouring fibres and that caused the increase in flexural rigidity in MD from 336 mg cm to 436 mg cm, which was 23% higher than the non-thermal bonded nonwoven fabric produced at same pressure, as shown in Figure 4.33.



**Figure 4.31** Fibres melting behaviour after calendaring process for flexural rigidity.

But the flexural rigidity in CD decreased by 13 mg cm it was because of more fibres comes in parallel in MD and there were limited bi-compoenet fibres in CD region, due to whcih thermal process did not affect on the flexural rigidity in CD region.

Figure 4.33 also demonstrated that the calendared samples showed higher FR both in the machine and cross direction. It was because of the bonding between the melted fibres due to the hot roller pressure that led to the stiffening of the fabric structure, thus an increase in FR value. Figure 4.31 demonstrated that after thermal bonding (calendering process), the fibres were melted and held together with the surrounding fibres. These melted and thermally bonded fibres increased the flexural rigidity of the calendared samples in the machine and cross direction.



**Figure 4.33** Bending behaviour of Nonwoven Fabric produced at 75 Bars Hydro Pressure.

#### 4.2.3.3 Fabric produced at 100 bars hydro pressure

In Figure 4.35, It apparent that the values of the flexural rigidity in MD gradually increased and there are insignificant variations in CD. It is known that when the hydro pressure increased the flexural rigidity increased in MD at some extent depends on the material and structure of the resultant fabric. The flexure rigidity of hydroentangled fabric increased to 352 mg cm as compared with the sample produced at 75 bars hydro pressure that was 336 mg cm in MD as shown in Figure 4.35. When pressure increased from 75 bars to 100 bars then because of pressure intensity the fibres were tightly entangled because of rebound of water from the underlying perforated belt due to which fibres were more oriented in MD and the fibres were also more compact

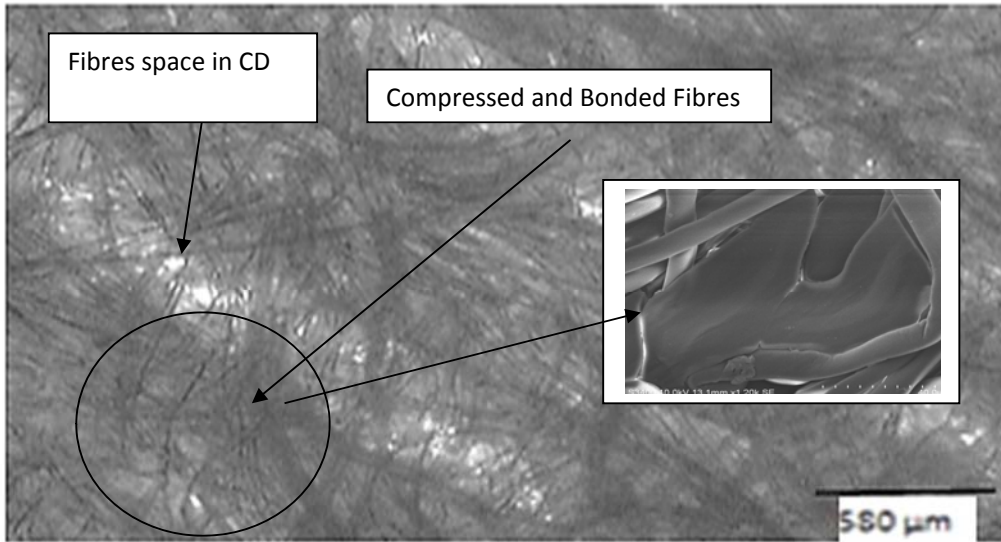
and entangled very well and because of alignment in the fibres there were very few fibres that entangled with CD fibres region so that enhanced the flexural rigidity of the sample in MD and CD.

It is demonstrated in Figure 4.35 that after thermal bonding process there were slightly increased the bending rigidity in machine direction and decreased in cross direction. The fibres were highly oriented in MD as mentioned earlier and the fibres were closely entangled like a strand in the fabric, so the thermal process did not effect on the bending performance of the fabric.

The decreased in CD was because of gaps between the fibres in CD region these gaps can be seen in the Figure 4.34, and there were also very limited fibres in CD that caused the lower bending rigidity of the sample in CD.

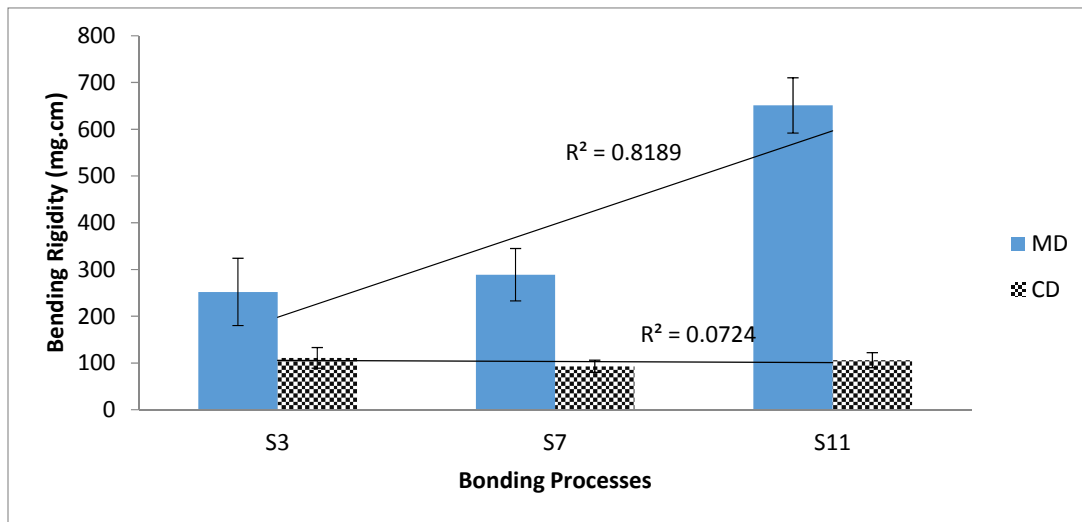
Calendering process increased the bending rigidity performance in MD and almost no change in CD as shown in Figure 4.34. At roller temperature 110°C top and 110°C bottom with 1 ton pressure sequestered the fabric and created strong bond between the fibres in MD as shown in Figure 4.34.

Calendared sample produced at 100 hydro bars also showed higher flexural rigidity as compared with the calendared sample produced at 75 hydro bars, it was because of compact structure of the sample that facilitate to create a strong thermal bonding between the fibres through hot rollers pressure. It can be observed from Figure 4.33 and 4.35 that after calendaring process, fabric produced at 100 bar hydro pressure exhibited almost 15% higher bending rigidity in MD.



**Figure 4.34** Microscopic view of sample (produced at 100 bars hydro) after calendaring process

Because of this strong bonding, a slightly stiff structure of the sample was produced that caused the increased the BR in MD. And because of limited fibres in the CD as shown in Figure 4.34, the calendaring process did not effect on it.



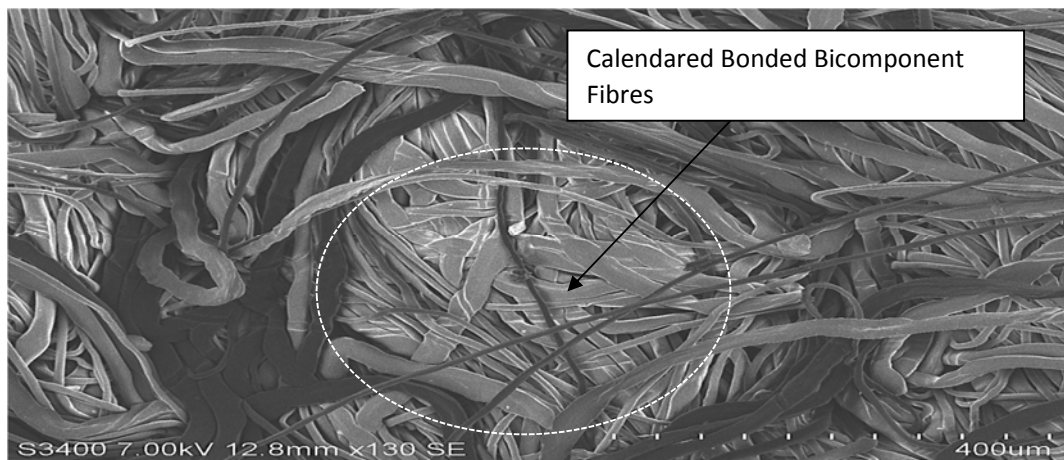
**Figure 4.35** Bending behaviour of Nonwoven Fabric produced at 100 Bars Hydro Pressure.

#### 4.2.3.4 Fabric produced at 125 bars hydro pressure

The results presented in Figure 4.37 show that the fabric produced at 125 bars hydro pressure exhibited higher BR (352 mg.cm) in the MD. In this sample, the fibres were tightly entangled like strands and aligned in the MD which resulted in strong bonding between the fibres. Furthermore there was limited space available for fibre movement in the the MD and on the other hand, there were fewer fibres in the CD region of the fabric and this caused a reduction in the BR value to 83 mg.cm from 111 mg.cm (sample proudecd at 100 bars hydro pressure).

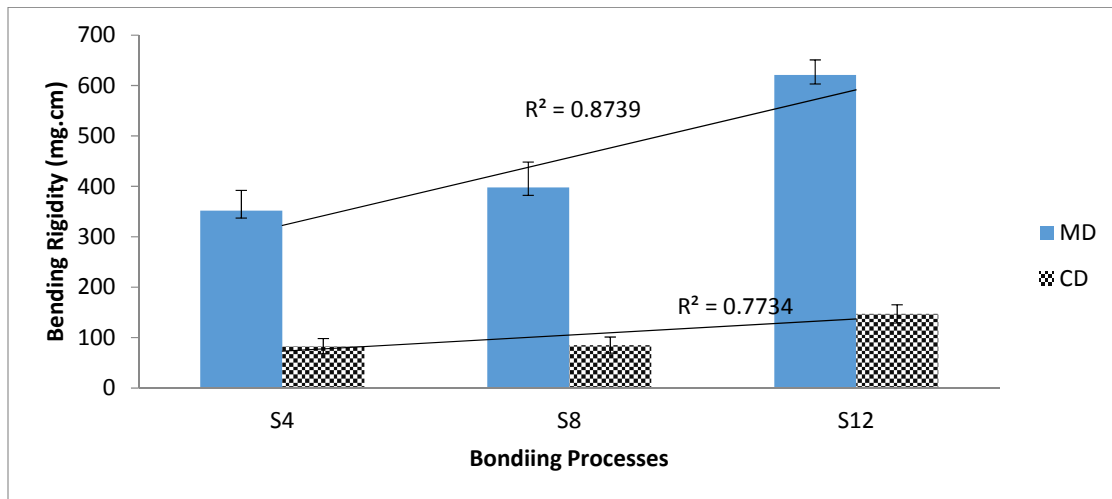
After the thermal process the BR of the fabric increased by 13% as compared to the hydroentangled sample produced at same pressure. The BR value was also higher (37%) than that for the corresponding sample produced at 100 bars hydro pressure and the thermally processed. There was no noticeable change observed in BR in the CD, as shown in Figure 4.37. The increased in BR in MD was due to the fact that the melted sheath part of bicomponent fibres created strong bonding between the fibres because of the good entanglement of the fibres in this direction.

After the calendaring process, the BR values were increased in both the MD and CD as compared to the hydroentangled sample produced at same pressure. As, it has been discussed earlier, because of the heated top and bottom rollers and the application of one ton pressure, the fabric was compressed and caused melting of PE of sheath part of the bicomponent fibre and created very strong thermal bonding between the fibres that restricted the motion of the fibres in the fabric structure in the machine and cross machine directions, more so in the MD.



**Figure 4.36** SEM of sample (produced at 125 bars hydro) after calendaring process

For nonwoven fabric, the bending rigidity mainly depends on the space for fibre movement and the bonding techniques. The results have shown that the hydroentangled fabric exhibited better BR than thermal and calendared bonded samples. After the thermal and calendaring processes, the space for fibre movement was gradually reduced due to strong bonding and the fibres were not able to move during the bending motion of the fabric.



**Figure 4.37** Bending behaviour of Nonwoven Fabric produced at 125 Bars Hydro Pressure.

#### 4.2.4 Moisture management

The moisture management in the fabric determines the cooling effect and therefore gives comfort to the wearer. Wear comfort of clothing has continually gained in importance. During exercise or working conditions the human body wets because of sweating of the liquid (sweat), which does not evaporate from skin to the atmosphere, as a result the wearer feels uncomfortable and tends to lose the working efficiency. Therefore, moisture management of the fabric is very important in order to optimise the wearer’s comfort and therefore the wicking property of a fabric played an important role in it (140).

The fabrics used for testing were prepared in-house and for comparison purpose a commercial nonwoven fabric (Evolon) was obtained from Freudenberg (Germany). Additionally, a conventional woven fabric was also studied and the results were compared with the nonwoven fabrics. The physical properties of the tested fabric are given in Table 4.10.

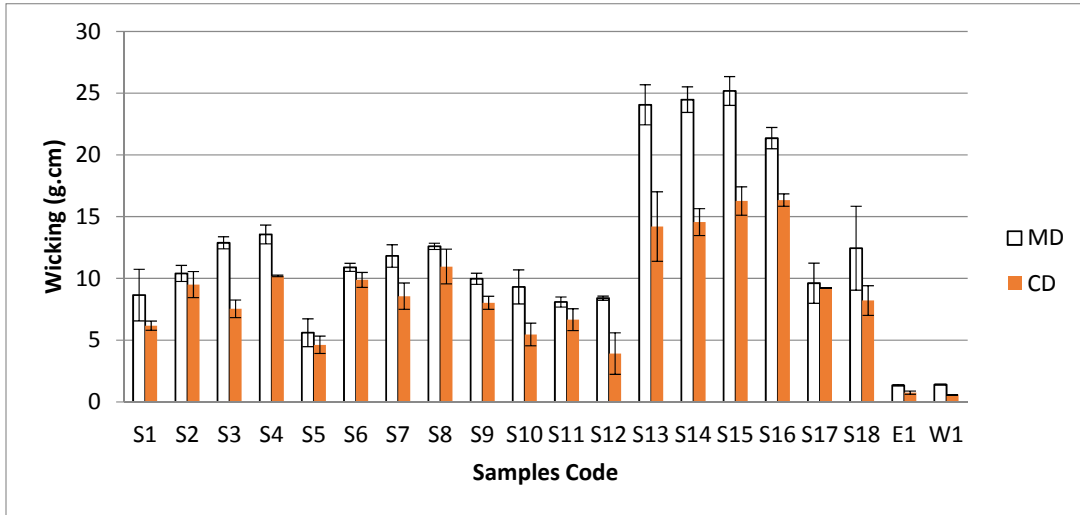
Liquid transport and the drying rate of the fabrics are the two pivotal factors of physiological comfort of garments. These two factors mainly depend on the fibre structure and their moisture uptake and drying behaviour. The main component of nonwoven fabrics developed in this study is Tencel fibre, which formed 70% of the material used for making these fabrics. Tencel fibres exhibit higher wet and dry tenacity values that are 34-38 CN/tex and 38-42 CN/tex, respectively. These values are higher than the other cellulosic fibres.

Furthermore, because of the micro structure, Tencel fibres possess high capillary capabilities that have led to the enhancement in the moisture management of the developed nonwoven fabrics. Wicking property is very important for apparel garments because during working conditions the fabric should absorb the moisture from the body and disperse it into the environment, which provide dryness to the body and enhances the comfort to the wearer.



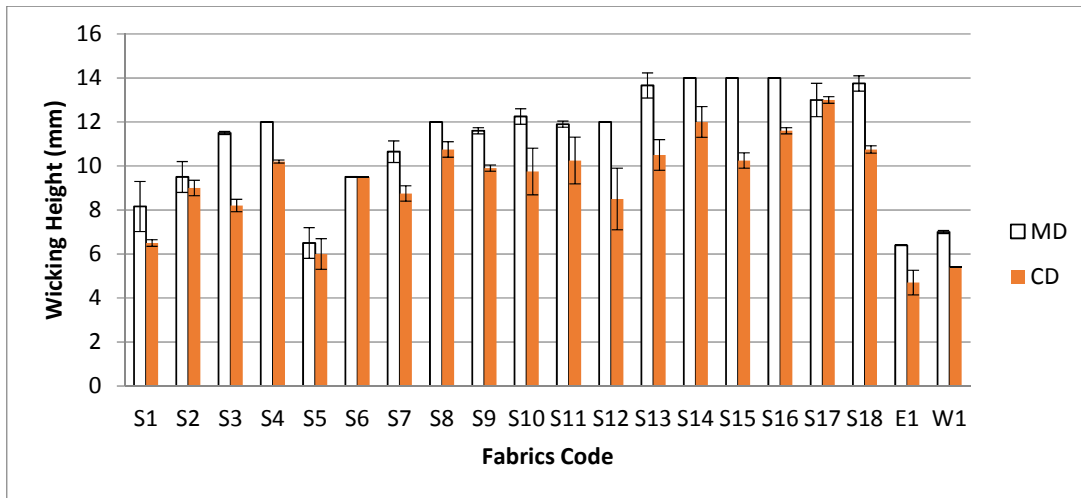
Table 4.10 Physical Properties of the Fabrics

Sample Name	Fabric	Bonding Technique	Thickness (mm)	Mass (g/m <sup>2</sup> )	Fibres types	Count dtex
	Nonwoven	Needle punched and Hydroentangled			Sheath/Core (PE/PET) and Tencel (Staple fibres) Blend ratio Bicomponent 30%/Tencel 70%	Sheath/core (2.2) and Tencel (1.4)
S1	50 bars		0.72	117		
S2	75 bars		0.44	111		
S3	100 bars		0.48	125		
S4	125 bars		0.46	120		
	Nonwoven	Needle punched and Hydro and Thermal				
S5	50 bars		0.72	117		
S6	75 bars		0.44	111		
S7	100 bars		0.48	125		
S8	125 bars		0.46	120		
	Nonwoven	Needle punched and Hydro and calendared				
S9	50 bars		0.72	117		
S10	75 bars		0.44	111		
S11	100 bars		0.48	125		
S12	125 bars		0.46	120		
	Nonwoven	Pre-needed Hydroentangled				
S13	100 bars		1.00	150		
S14	125 bars		0.88	150		
	Nonwoven	Pre-needed Hydroentangled and thermal				
S15	100 bars		1.00	150		
S16	125 bars		0.88	150		
	Nonwoven	Pre-needed and Hydroentangled and Calendared				
S17	100 bars		1.00	150		
S18	125 bars		0.85	150		
E1	Nonwoven (Evolon)	Spunlaying and hydroentangled	0.43	140	Island in sea (PET/PA6) -Continuous Filament	
W1	Woven	Weave (1x1)	0.50	144	Yarn (cotton)	30tex



**Figure 4.38** Wicking behaviour of nonwoven and woven fabric in machine and cross directions.

Figures 4.38 and 4.39 represent the capillary absorption ability and the wicking height of nonwoven and woven fabrics, respectively. The capillary absorption ability followed the same trend as the wicking height. The higher the wicking height the greater the amount of water absorbed by the fabrics. It was because of using the finer fibres, which created smaller capillary pores within the fabric structure, the wicking ability of the fabric was enhanced due to the higher capillary pressure.



**Figure 4.39** Wicking height of Developed Nonwoven and References Fabrics in Machine and Cross Directions

Figure 4.38 also shows that the wicking capability of the fabric was in general higher in the MD than the CD. It was due to the capillary angles in the fabric. In the MD the fibres were in rectangular shape that supports the wicking process and on the other hand in the CD the fibres were at 180<sup>0</sup> or “X” axis direction that reduces the upward water transportation.

The developed hydroentangled fabric gave higher capillary pressure because of the fibril structure of the Tencel fibres and also because of the finer count, as mentioned in Chapter 3. From Figure 4.38 it is apparent that the developed nonwoven samples exhibited much higher wicking behaviour than the woven and commercial hydroentangled nonwoven fabric in terms of absorption of liquid. Xiao Chen et al (92) found that the addition of finer fibre in a blend improved the absorption ability of the coarser fibres. There were three main reasons for the enhancement of the wicking properties of the developed nonwoven samples:

1. Fabric structure comprised of short fibres rather than continuous filaments.
2. The fibres used for making nonwoven fabrics were finer
3. Bonding technique between the fibres

Parada, et al (141) found that the wicking process is a two stage process where the liquid displaces the air within the fabric structure. Therefore, because of their porous structures, the developed samples showed higher wicking properties than the commercial hydroentangled and woven fabrics. The nature of the nonwoven fabrics structure very much depends on the fibre types used and the intra-fibre bonding created through the bonding process.

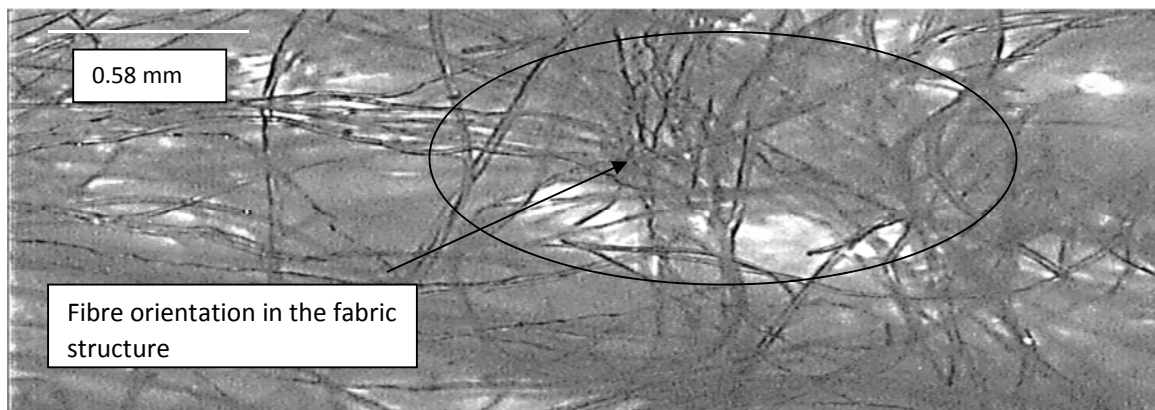
The nonwoven fabrics produced in this study had porous structures due to the staple fibres used and the needlepunching and hydroentanglement fibre bonding processes employed. On the other hand the woven fabric was made by using continuous yarns, which were interlaced to make the woven fabric. The porous structure of a nonwoven fabric gives better capillarity than a woven fabric and hence the better wicking behaviour observed for the nonwoven fabrics than the woven fabric as shown in Figure 4.38.

The fabric finishing techniques also affect the wicking properties of a fabric. Sample S3, which was firstly needlepunched then hydroentangled, showed wicking value of 12.8 g.cm in the MD and after the calendaring process the same sample (S11)

exhibited a value of 8.09 g.cm in the MD. The decline in the wicking capability of the sample after the calendaring was because of the decrease in the movement of water in the fabric. This sample (S3) was produced using a blend of fibres containing 70% Tencel and 30% bicomponent sheath/core PE/PET. During the calendaring process the sheath part of the bicomponent fibre was melted due to the effect of temperature and the roller pressure, which caused spreading of the melted fibre into the fabric spaces and minimised the water movement in the fabric thus resulting in the lower wicking value for sample S11 as shown in Figure 4.38. The pressure of the heated rollers reduced the capillary tubes in the fabric structure by pressing the fabric structure as shown in Figures 4.40C and 4.40d.

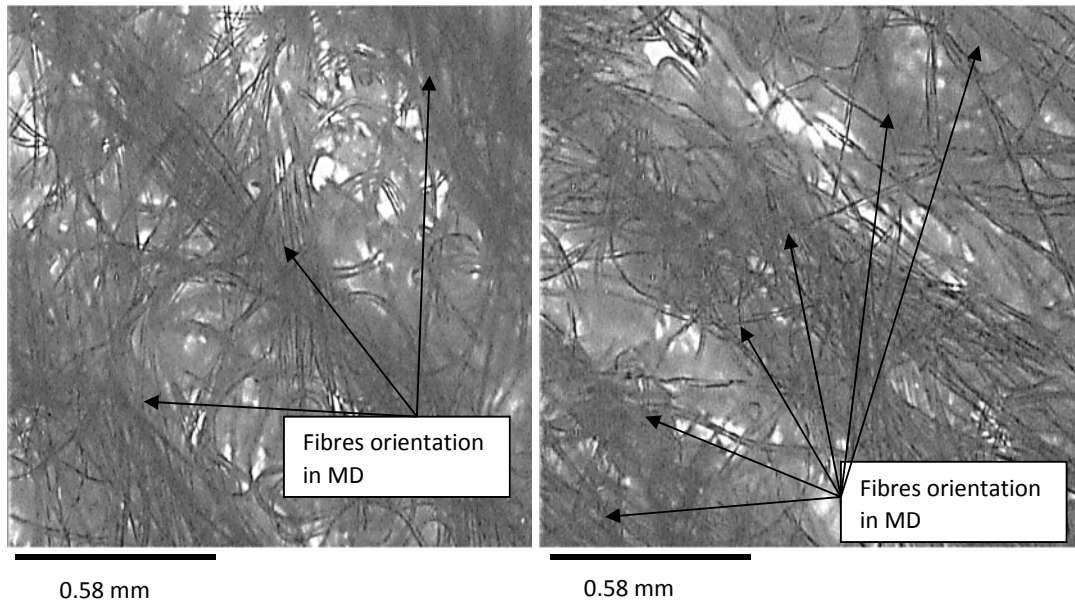
#### 4.2.5 Hydroentangled nonwoven fabric

Another interesting observation was that the wicking capability was increased gradually from S1 to S4 because of the increased intensity of the fibre entanglement and the development of capillary structures in the fabric region, with an increase in the hydro pressure. Sample S1 was prepared at 50 bars hydro pressure and at this level intensity was not sufficient to entangle the fibres very closely and produce a compact fabric structure. Therefore, the fibres were not close enough to create an effective capillary structure for water movement. Figure 4.40 shows that the fibres were not oriented and they were free to move and therefore could not create an effective capillary structure in the fabric for the movement of water. These appear to be the main factors for the observed lower wicking rate for sample S1 as compared to the samples produced at the higher hydro pressures.



**Figure 4.40** Microscopic view of hydroentangled nonwoven fabric S1 produced at 50 bars hydro pressure (0.58mm)

When the hydro pressure was increased from 50 to 75 bars, the nonwoven sample produced S2 exhibited higher wicking rate. As the hydro pressure was increased further, the samples prepared S3 and S4 showed enhanced wicking behaviour. This is a result of the increased intensity of entanglement, which produced a more compact nonwoven structure and better alignment of fibres. Figures 4.40a and 4.40b show that as the hydro pressure was increased the fibres tended to align in one direction and they appear like strands in the fabric region. These strands created the capillary structure within the fabric thus the samples produced at the higher hydro pressures showed higher wicking rate than the sample produced at the lower hydro pressure (Figure 4.38).



**Figure 4.40a** Fabric S2

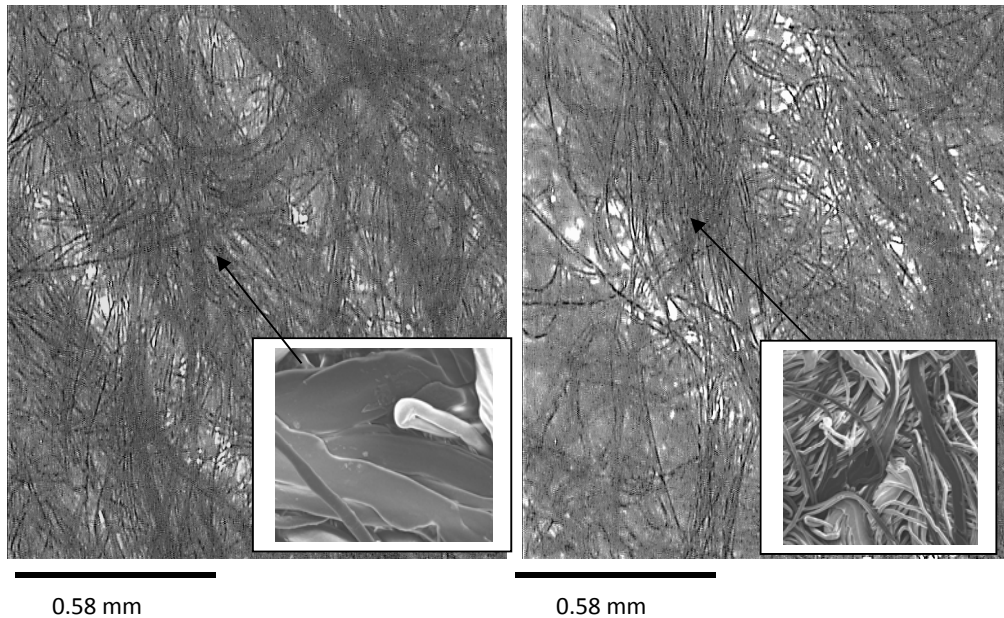
**Figure 4.40b** Fabric S4

#### 4.2.5.1 Hydroentangled and thermal bonded fabrics

The thermally bonded samples (S5 to S8) showed lower wicking rate than the corresponding hydroentangled samples (S1 to S4). Thermal bonding process caused the melting of the low temperature melting sheath part (PE) of the bicomponent fibres and created enhanced bonding between the fibres. However, there were no noteworthy differences observed between the wicking rate of the hydroentangled and thermal bonded fabric as shown in Figure 4.38.

#### 4.2.5.2 Hydroentangled and calendared bonded fabric

The calendared samples S9 to S10 showed minor changes in wicking after hot rays' thermal bonding process mainly because of fabric loose structure. S11 and S12 showed lower wicking rate than the thermally bonded and hydroentangled fabrics. The wicking rate for sample S11 (8.09 mg.cm in MD and 6.66 mg.cm in CD) was lower than S3 (12.8 mg.cm in MD and 7.5 mg.cm in CD) and S7 (11.82 mg.cm in MD and 8.56 mg.cm in CD). These results clearly show that after the calendaring process the wicking performance of the fabrics was reduced. This appears to be the result of the melting of the sheath part of the bicomponent fibres, which filled the pores of the capillary structure of the fabric. It can be seen in the Figures 4.40c and 4.40d that the structures of S11 and S12 were compressed and some of the pores were filled with the molten polymer (PE) from the bicomponent fibre.



**Figure 4.40c** Calendared Sample S11    **Figure 4.40d** Calendared sample S12

#### 4.2.6 Woven and Evolon samples

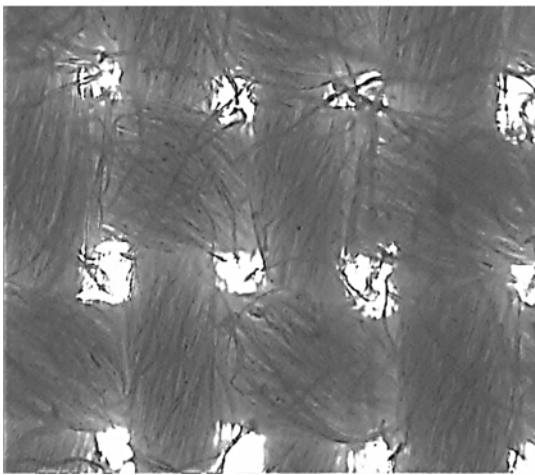
Woven fabric (W1) exhibited very low wicking absorption which was 1.34 mg.cm in MD and 0.75 mg.cm in CD. It was because of the structure of the woven fabric, which is comprised of the interlacing of the yarns and the fibres inside the yarns were twisted and tightly spun. Secondly, the interlacing of the yarns was in a zigzag pattern as shown in Figure 4.40e and there was a little chance for wicking/absorption to occur in

the woven fabric. These results show that the woven fabric's wicking absorbency was much lower than the nonwoven fabrics developed in the current study (Figure 4.38).

Evolon E1 also showed lower wicking and absorbency values in the MD and CD as compared to all the nonwoven samples prepared. There were two main factors that reduced the wicking absorbency of Evolon 100 PK fabric:

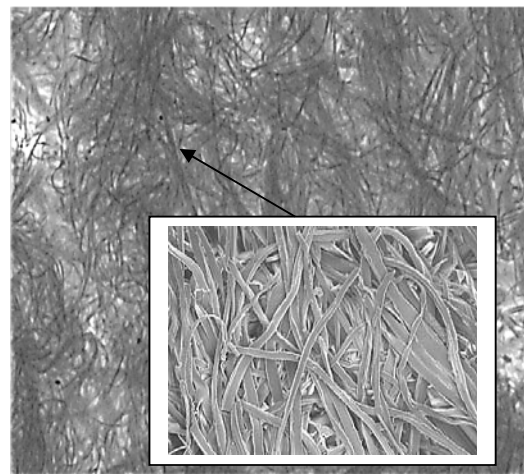
1. Bonding techniques between the fibres
2. Fabric structure

Evolon fabric was produced through the spunlaying and hydroentanglement processes. During spunlaying process, the fibres were bonded closely and after the hydroentanglement process the fibres were split into fibrils that minimised the capillary structure of the fabric. It is visible in Figure 4.40f that the fibres are dispersed into many directions, not in one direction, and it is also demonstrated that there are no pores in structure of the fabric. Because of these factors Evolon 100 PK exhibited lower wicking absorbency than the nonwoven samples developed in this study as shown in Figure 4.38.



0.58 mm

**Figure 4.40e** Woven fabric (W1)



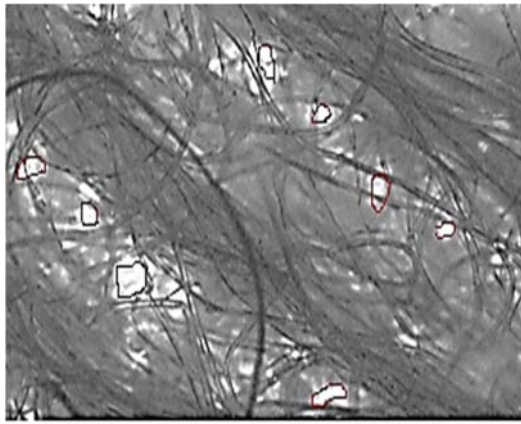
0.58 mm

**Figure 4.40f** Evolon 100PK (E1)

#### **4.2.7 Hydroentangled fabric (pre-needling)**

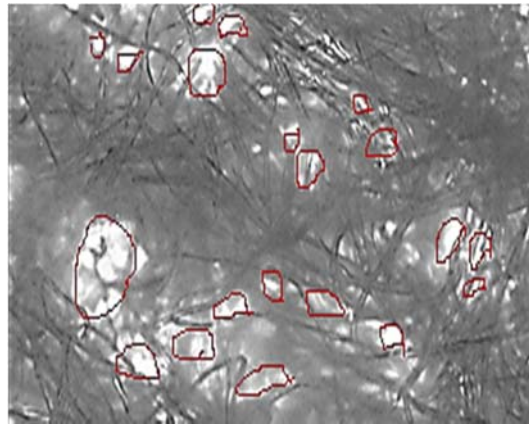
The fabric produced through the hydroentanglement process with pre-needling exhibited higher wicking absorbency. Fabric S13 and S14 were produced through the hydro process after pre-needling process. S13 and S14 showed MD absorbency

values of 24.06 mg.cm and 24.48 mg.cm, respectively. These samples exhibited almost 100% higher wicking absorbency in MD as compared to S3 and S4, which were produced through the combined needlepunching and hydroentanglement processes at same pressure. The basic difference between S13, S14 and S3, S4 was the needlepunching process. S3 and S4 showed lower wicking absorbency than S13 and S14, it was because of the dispersion of the fibres during needling process. During needling process, when the needle bat hit the fibrous web then the fibres were dispersed into different directions which reduced the number of fibres per unit area of the fabric and increased the pore size that reduced the capillarity of the fabric structures in S3 and S4. Miller (142) have reported the effect of pore size on the wicking behaviour of a material. He found that the smaller pore size gives better capillary action than the larger pore size.



0.58 mm

**Figure 4.40g** Fabric (S3)



0.58 mm

**Figure 4.40h** Fabric (S1)

The fabric samples S13 and S14, produced through the hydro process after light pre-needling, exhibited higher wicking absorbency. This is due to the presence of higher number of fibres per unit area and the greater orientation of fibres in the fabric, which leads to the enhanced wicking performance of samples S13 and S14 as shown in Figure 4.38. It is evident that at the higher pressure more fibres are oriented in the MD as shown in Figure 4.40b. It was also concluded by Mao and Russell that the water jet pressure has a significant effect on the entangling and reorientation of the fibres within the structure of a nonwoven fabric (111).



#### **4.2.7.1 Hydroentangled and thermal bonded fabric (pre-needling)**

S15 and S16 fabrics were thermally bonded after the hydroentanglement process. There were very nominal differences in the wicking absorbency of S15, S16 and S13, S14. Sample S15 showed 25.18 mg.cm wicking absorbency in the MD and 16.27 mg.cm in the CD, which were slightly higher than S13 that showed 24.06 mg.cm in the MD and 14.2 mg.cm in the CD. This shows that the thermal bonding process does not affect the wicking property of the fabric, which was produced through only hydroentanglement process.

#### **4.2.7.2 Hydroentangled and calendared fabrics (Pre-needling)**

Calendared samples S17 and S18 showed lower wicking absorbency than the corresponding non-calendared samples S13 to S16. However, their wicking absorbency was still higher than the woven and Evolon fabrics. The effect of the calendaring process on the wicking capability of the fabric has been discussed earlier. S17 showed 9.61 mg.cm wicking absorbency in the MD and 9.26 mg.cm in the CD, which is 150% lower than S13 in the MD and 53% lower in the CD. The values for S18 were 96% lower than S14 in the MD and 77% in the CD, as shown in Figure 4.38.

#### **4.2.8 Absorption**

Liquid diffusion and structural properties of nonwoven materials are strongly interlinked (92). There are different factors that affect the absorption properties of the fabric such as, fabric weight, blend ratio, consolidation of fibres, fabric thickness, and fabric density (91). Figure 4.41 shows that the absorption properties of the developed hydroentangled nonwoven fabrics were higher than the woven and commercial hydroentangled nonwoven fabrics studied. Sample S5 showed the highest absorption values of all tested samples due to the differences in the structure of the sample.

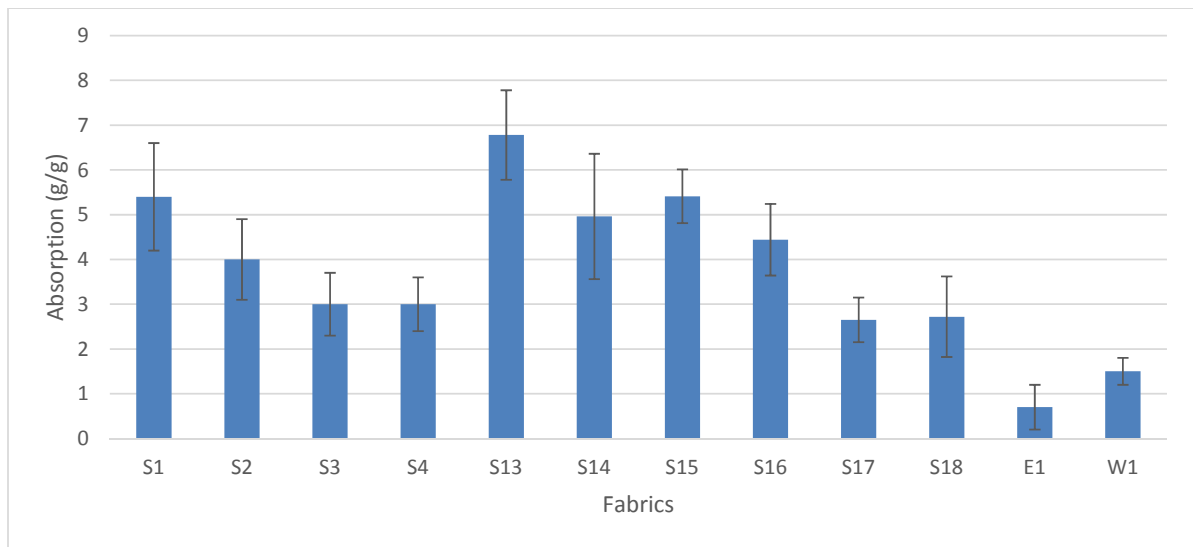
Sample S13 was prepared through the pre-needling and the hydroentanglement process at 100 bar hydro pressure, where the fibres in the fabric structure were consolidated or entangled in a specific pattern that gave maximum pore structure for absorption of water. Therefore, there more spaces were available between the fibres, which caused the higher absorption compared to the other developed hydroentangled nonwoven, the commercial hydroentangled nonwoven and the woven fabric.

Carter et al, (143) found that the capillaries in the fabric structure created by the fibres hold the water. Its mean the hydroentangled fabric S13 produced at 100 bars with pre-

needling process had more capillaries than the other developed fabrics. This is also an evident from Figure 4.39, where sample S13 showed higher wicking values among the other developed samples. The absorption and retention of a liquid can be considered by the capillary pressure of the liquid in the pores of the material, which can be defined by the Laplace equation (155)

$$P = (2Y\cos\theta)/r$$

Where P is the capillary pressure, Y is the surface tension of the wetting liquid,  $\theta$  is the contact angle between the liquid and the capillary wall and “r” is the radius of the capillary. The liquid absorption is directly proportional to the capillary pressure (144). The liquid absorption properties of a nonwoven can be improved by two factors; either by decreasing the contact angle of the liquid between the fibres or by decreasing the average pore size of the nonwoven (144).

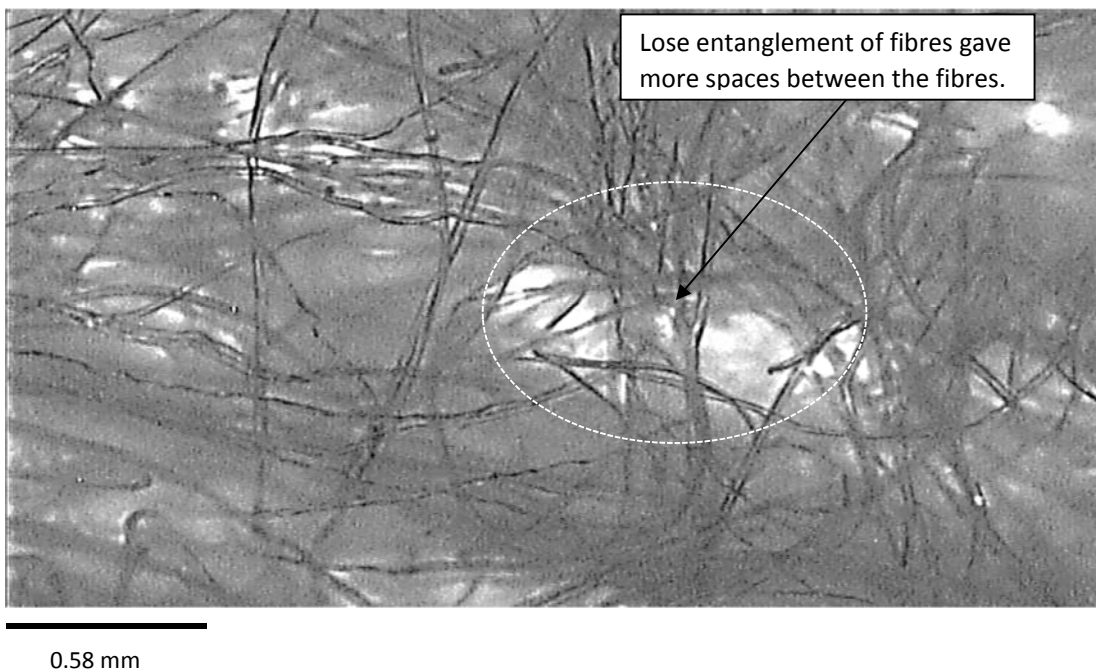


**Figure 4.41** Absorption values of fabrics.

**Table 4.11** Samples Details

<b>Samples Code</b>	<b>Thickness (mm)</b>	<b>Process</b>	<b>Absorbency values (g/g)</b>
S1	0.72	Needledpunched and Hydroentangled @50 bar	5.4
S2	0.44	Needledpunched and Hydroentangled@75 bar	4
S3	0.48	Needled punched and Hydroentangled @ 100 bar	3
S4	0.46	Needledpunched and Hydroentangled @125 bar	3
S13	1.00	Pre-needled and hydroentangled @100	6.78
S14	0.88	Pre-needled and hydroentangled @125	4.96
S15	1	Pre-needled and hydroentangled @100 with Thermal Process	5.41
S16	0.88	Pre-needled and hydroentangled @125 with Thermal Process	4.44
S17	1.00	Pre-needled and hydroentangled @100 with Calendared Process	2.65
S18	0.88	Pre-needled and hydroentangled @125 with Calendared Process	2.72
E1	0.43	Commercial Hydroentangled Nonwoven Fabric	0.7
W1	0.50	Woven Fabric	1.5

The results presented in Figure 4.41 show that the absorption values decrease from S1 to S4. This is mainly due to the greater consolidation of the nonwoven fabric structure, which is a result of the increase in the hydro pressure during the production of these fabrics. S1 was prepared at 50 bars hydro pressure where the fibres were not intensively consolidated or entangled with the surrounding fibres. At this pressure level, the intensity was not enough to entangle the fibres closely due to which the resulting structure of S1 was loose and there were many spaces between the fibres as shown in Figure 4.42a. This led to the higher absorption values for S1 as compared to S2 to S4.



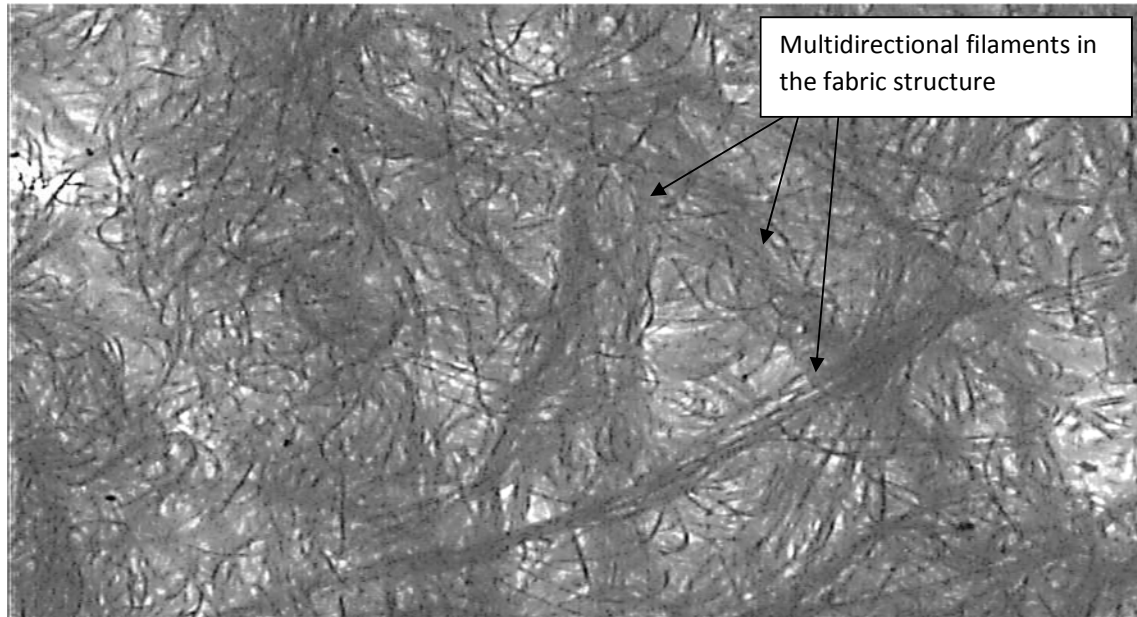
**Figure 4.42a** Microscopic view of hydroentangled sample prepared at 50 bars hydro pressure.

Samples S2, S3 and S4 were prepared at 75, 100 and 125 bars hydro pressures, respectively. S2 showed lower absorption value than S1 but higher than S3, S4, S17, S18, E1 and W1. Sample S2 was prepared at 75 bars hydro pressure and at this level of pressure the fibres were consolidated and the thickness of the fabric was reduced to 0.44 mm from 0.72 mm (Table 4.11). The reduction in thickness was the indicator that the air space between the fibres were reduced and more fibres were entangled and aligned in the fabric region leading to a reduction in the absorption capability of the fabric. Same phenomena were observed for S3 and S4.

As discussed earlier, S13 was prepared through the pre-needling and hydroentanglement processes. Otherwise the samples from S1 to S4 were prepared through the hydro process but these samples were needlepunched prior to undergoing the hydro process. During the needling process the number of fibres per unit area of the fabric were reduced due which there were less pores in the structure of the fabric for holding the water inside the fabric. On the other hand the sample produced through the hydro process with pre-needling had higher number of fibres per unit area of the fabric, which enhanced the water absorption performance of the fabric as shown in Figure 4.41.

Sample S17 and S18 exhibited lower water absorption than the other developed samples but higher than Evolon E1 and woven W1. Samples S17 and S18 were first prepared through the hydro process then they were calendared. Due to the calendaring process the low-melting part of the bicomponent fibres were melted and because of pressure rollers the melted polymer was spread inside the fabric, which created strong bonding between the fibres and minimised the air spaces between the fibres and restricted the absorption of water, which caused the lower water absorption values as presented Figure 4.41.

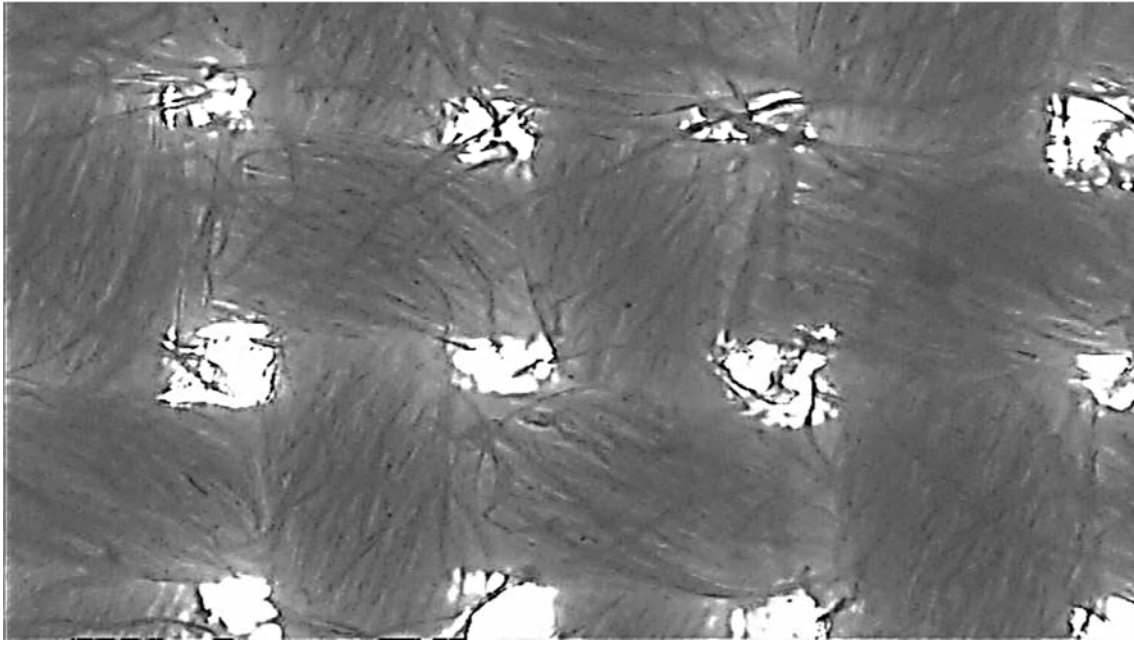
Commercial hydroentangled nonwoven fabric E1 exhibited lower absorption values than all other tested samples. The commercial hydroentangled nonwoven fabric E1 was prepared through the hybrid spunlaying/hydroentanglement process. During spunlaying the filament fibres were attached to the surrounding fibres that created thermal bonding between the fibres and after hydro process the fibres were split into fibrils that reduced the air space between the fibres as shown in Figure 4.42b. Furthermore, E1 fabric was comprised of 70% PET, which is a hydrophobic fibre, which also caused reduction in the capacity of the fabric to uptake water. Because of these factors, commercial hydroentangled nonwoven fabric showed much lower value of absorption (0.7 g/g). Figure 4.42b demonstrates that there were nominal spaces between the fibres due to which there are limited number of pores for water absorption to take place by the fabric.



0.58 mm

**Figure 4.42b** Microscopic view of Evolon (E1) 100 PK

The woven fabric W1 showed absorption value of 1.5 g/g, which is higher than Evolon E1 but lower than all the other nonwoven samples. The composition of the woven fabric was different from that of Evolon and the developed nonwoven fabrics. The woven fabric is produced from continuous yarn based on 50:50% cotton and PET blend and thus exhibited lower absorption than the developed nonwoven samples. Furthermore, because of the twisted nature of the yarn, the number of spaces between the fibres were very low and could not hold any significant amount of water in the pores of the fabric. This led to the low absorbency values observed for the woven fabric as compared to the nonwoven fabric samples prepared in this study.



0.58 mm

**Figure 4.42c** Microscopic view of woven fabric (W1)

From Figure 4.42c, it can be seen that there are virtually no spaces between the fibres in the yarn because of the tightness of the yarn and the compression of the weave during the weaving process. Yarn count also plays an important role in the absorption performance of the fabric and in this case the yarn count was 30tex, which means a fine yarn was used that reduced the absorption capability of the woven fabric. Woven fabric showed holes in its structure but these holes were not capable of holding the water because of the lack of capillary frictional forces that are responsible for retaining the water in the pore structure of the fabric.

#### **4.2.8.1 Effect of fabric density on absorption of fabric**

The fabric bulk density (FBD) and fabric thickness also play an important role as for as water absorbency is concerned. It is observed from the Figure 4.43 that water absorbency decreases with the increase in the FBD up to a point and then with any further increase in FBD the absorbency values tend to decrease. The water holding capability of fabric depends on two components: one is fabric structure and the second is the nature of the fibre nature and its structure.

**Table 4.12** Samples for tested for absorption

Samples Code	Thickness (mm)	Fabric Bulk Density (g/cm <sup>3</sup> )	Absorbency values (g/g)
S1	0.72	0.162	5.4
S2	0.44	0.252	4
S3	0.48	0.260	3
S4	0.46	0.260	3
S13	1.00	0.150	6.78
S14	0.88	0.170	4.96
S17	1.00	0.150	2.65
S18	0.88	0.170	2.72
E1	0.43	0.320	0.7
W1	0.50	0.290	1.5

Sample S1 showed absorbency value of 5.4 g/g with FBD value of 0.162 g/cm<sup>3</sup>, on the other hand S2 exhibited 4 g/g absorbency with FBD of 4 g/cm<sup>3</sup>. Sample S3 had absorbency of 3 g/g with FBD value of 0.260 g/cm<sup>3</sup>. Therefore, the results illustrated in Figure 4.43 clearly show that the absorbency values decrease with the increase in the FBD. This observation is related to the higher compaction of the nonwoven fabrics produced at higher hydro pressure values. The sample S1 produced at 50 bars hydro pressure exhibited higher absorbency (5.4 g/g) and the samples produced at 75 (S2) and 100 bars (S3) hydro pressure exhibited somewhat reduced (4 and 3 g/g respectively) absorbency values. It is obvious that with the increasing hydro pressure, better entanglement of fibres takes place and as a result fabric structure becomes more compact. The compact structure possesses fewer numbers of pores, which limits the water holding capacity of the fabric.

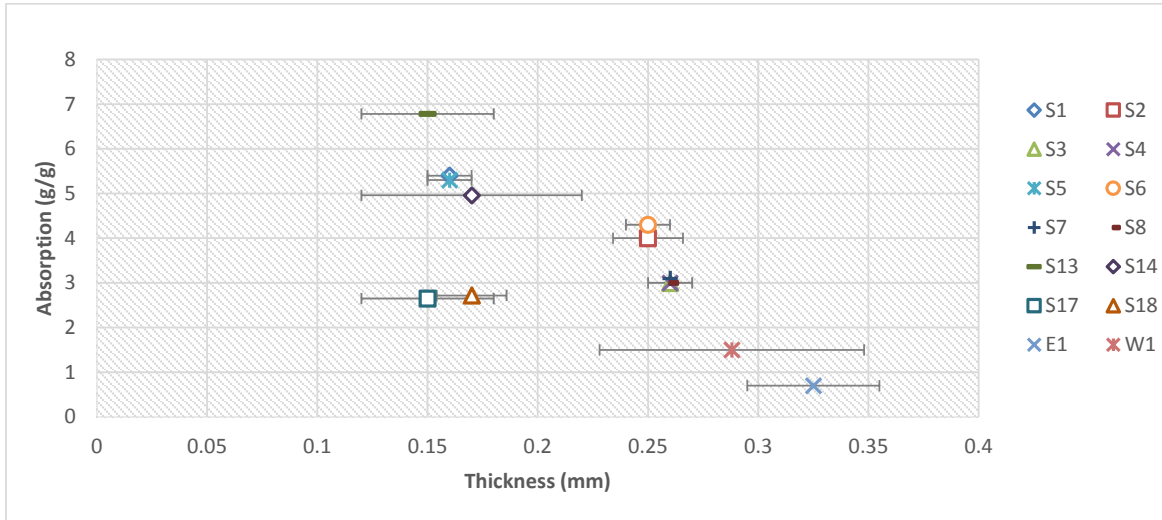
Fabric bulk density of sample S13, produced by using the hydroentanglement process only ( pre-needling), was 0.15 g/cm<sup>3</sup>, however it showed absorbency value of 6.78 g/g, which is much higher than all the nonwoven and woven fabric samples as shown in Figure 4.43. This sample was prepared at the hydro pressure of 100 bars, which results in more capillaries in the fabric structure thus enhancing the water uptake within the fabric structure. On the other hand, S14 was prepared at 125 bars hydro pressure



and it showed 4.96 g/g absorbency with 0.170 g/cm<sup>3</sup> fabric bulk density. At this pressure, fibres were tightly entangled that reduced the air gaps between the fibres within the structure of the fabric; this caused the lower absorbency than S13. Sample S17 and S18 were finished with the calendaring process and showed absorbency value of 2.65 g/g and 2.72 g/g, respectively. Due to the calendaring temperature and pressure, the low melting part of the bicomponent fibres melted and created a thin layer between the fibres that blocked the air spaces between in the fabric thus leading to the observed reduction in the water absorbency values of S17 and S18.

Evolon sample E1 showed 0.7 g/g absorbency values with 0.32 g/cm<sup>3</sup> fabric bulk density, this value was lower than all of the other tested samples. The structure of Evolon was much consolidated because of its fibre contents and its manufacturing process. Bicomponent (island in sea) filaments fibres used in the production of the fabric resulted in a fibril structure and there were very few spaces between the fibres for taking up water thereby leading to the observed reduction in the absorbency value of the fabric (Figure 4.42b). Second, because of the fibres structures, it has synthetic structure and that did not allow the commercial fabric to absorb more water.

Woven fabric (W1) showed 1.5 g/g absorbency value with 0.290 g/cm<sup>3</sup> fabric bulk density. This value is higher than Evolon fabric (E1) but lower than all of the other nonwoven samples as shown in Figure 4.43. As discussed earlier, the fibres in the yarn are very compressed and there were nominal spaces for water intake to take place by the fabric.



**Figure 4.43** Effect of fabric density on the absorption of the fabrics at different fabric weight

#### 4.2.8.2 Effect of fabric thickness on absorption of the fabric

The results presented in Figure 4.44 show that with the increase in the thickness of the fabric the absorption values for the fabric tend to increase. For example, the thickness of S1 was 0.72 mm and it showed 5.4 g/g water absorption while sample S2 showed 25% lower absorption value than S1 because it possessed lower thickness value of 0.44 mm. As the thickness of the fabric was reduced, it resulted in more fibres per unit area of the fabric and the air spaces between the fibres were reduced which lowered the water absorption character of the fabric.

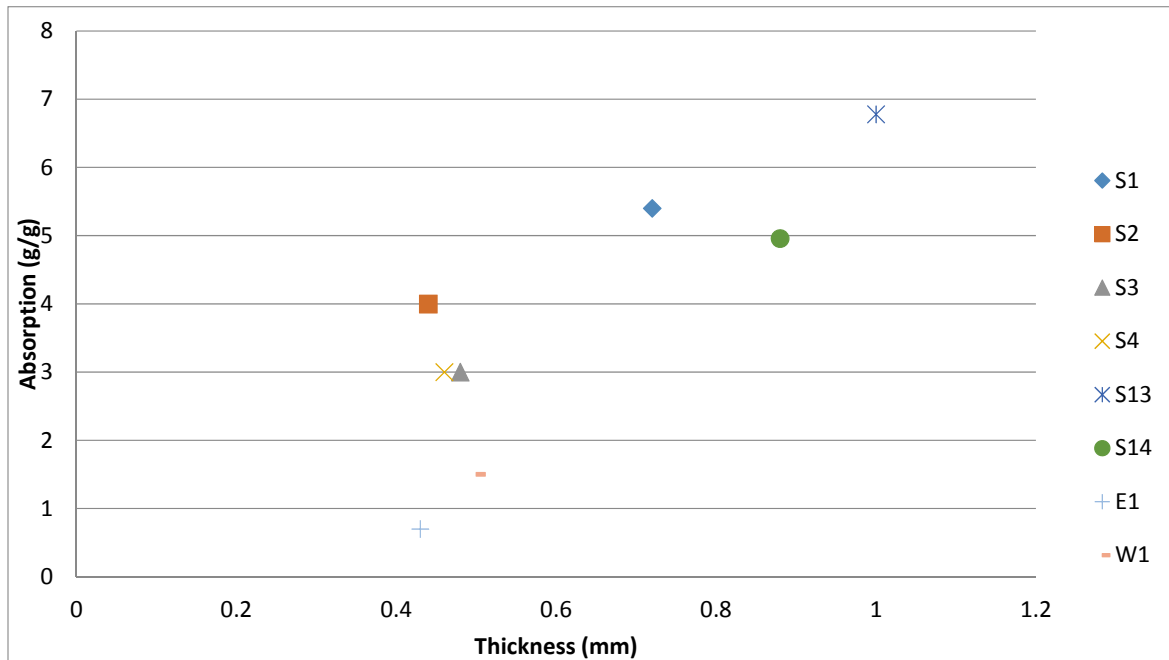
**Table 4.13** Effect of fabric thickness on water absorption

Sample Codes	Thickness (mm)	Absorption (g/g)
S1	0.72	5.4
S2	0.44	4
S3	0.48	3
S4	0.46	3
S13	1.00	6.78
S14	0.88	4.96
E1	0.43	0.7
W1	0.5	1.5

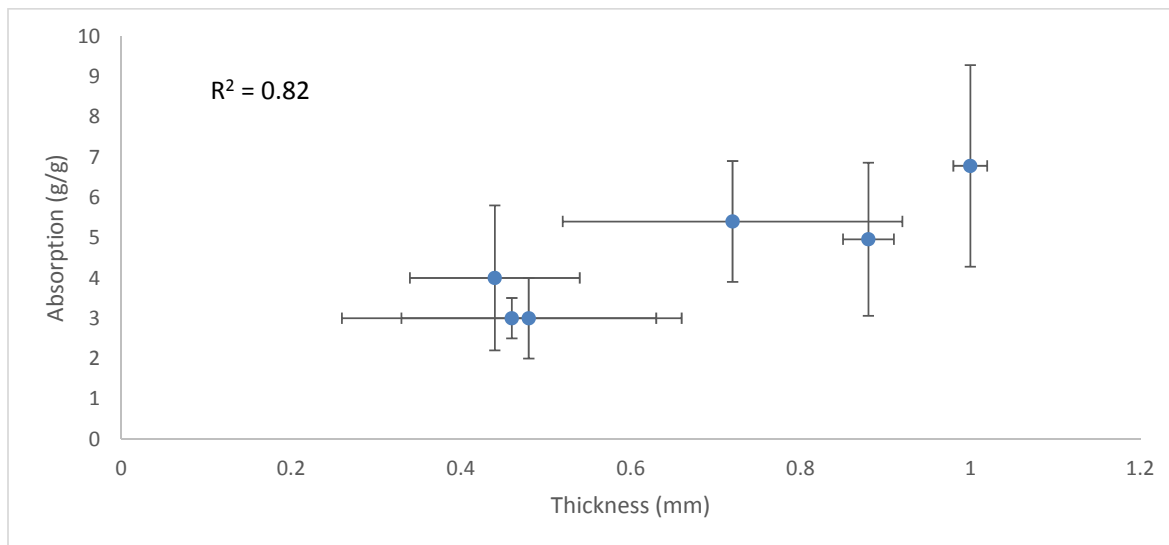
The reduction in fabric thickness was a result of the increase in the water pressure - S1 was prepared at 50 bars hydro pressure and S2 was prepared at 75 bars hydro pressure. Samples S3 and S4 also showed lower thickness values than S1 and S2 because these fabrics were prepared at higher hydro pressures (100 and 125 bars) and the higher intensity of water caused greater entanglement of the fibres and resulted in very compact fabric structures thus reducing the number of air spaces between the fibres. This caused the observed reduction in water absorption capacity for S3 and S4 as compared to S1 and S2. However, the samples still showed absorption values 76% higher than the Evolon E1 nonwoven fabric and 50% higher than the woven W1 fabric, as illustrated in Figure 4.44.

Sample S13 exhibited 6.78 g/g absorbency value with the thickness of 1.00 mm. This absorbency value is higher than all the tested samples mainly due to the fact that the thickness of this sample was higher than all the other samples. Sample S13 showed 90% higher absorbency than Evolon E1 and 78% higher than the woven W1 fabric (Figure 4.44). Because of the higher thickness of the fabric, there were more space between the fibres and the cellulosic structure of the Tencel fibres also played a significant role in enhancing the absorbency of this sample. On the other hand Evolon E1 fabric is composed of 70% PET and 30% polyamide and these fibres result in fibril structure because of the bicomponent natures of the fibres (island in sea), which split during the fabric production process and reduce the number of spaces between the fibres and as a consequence very low absorbency (0.7 g/g) was obtained for the Evolon E1 fabric as compared to all other samples. Although the thickness of the Evolon E1 fabric was 0.43 mm but it showed the lowest value of absorbency because of its structure, as discussed above.

The thickness of the woven W1 fabric was 0.50 mm thickness and the absorbency value was 1.5 g/g, which was higher than the Evolon E1 nonwoven but lower than all of the nonwoven samples developed in this study. The woven structure was very compact and the fibres were under stress because of the spinning and weaving processes. There were not many spaces between the fibres in the yarn, which resulted in the observed reduction in the absorbency value of the fabric and secondly the PET content in the fibre blend also caused the lower absorbency value of the woven fabric as shown in the Figure 4.44.



**Figure 4.44** Effect of fabric thickness on water absorption at different fabric weight



**Figure 4.44a** Correlation between the thicknesses and the absorption behaviour of the hydroentangled fabrics

The results presented in Figure 4.44a show a strong positive correlation between thickness and the absorbency behaviour of the hydroentangled nonwoven fabrics. As the thickness increased the absorbency capacity of the fabric was increased. Such as, the sample S3 having the thickness nearly 0.48 mm showed lower absorbency capacity as compare with the sample S13 that showed 1 mm thickness. It was because

of the air space between the fibres, as more space between the fibres made the fabric more absorbent and vice versa. Second, S3 sample was prepared through needle punched and hydroentanglement process, whereas, S13 was hydroentangled after pre-needling process, S13 possessed higher number of fibres in per unit area of the fabric that enhance the number of pores in the fabric structure.

#### **4.2.9 Tensile properties of hydroentangled nonwoven fabrics produced through needlepunching process**

The tested samples were prepared through the hydroentanglement process. The hydroentanglement process is highly energy intensive compared to the other nonwoven fabric production methods such as needlepunching. Hydroentanglement is a more suitable method for making nonwoven fabrics with good aesthetic characteristics for different applications, particularly for apparel use (62). In this study different types of nonwoven hydroentangled fabrics were prepared at different hydro pressures and some of the fabric samples were subjected to the thermal and calendaring processes in order to improve their tensile properties. The developed fabrics were compared with a control woven fabric and commercially available nonwoven fabric that are aimed at apparel applications.

Cannoly and Parent (145) found that the increase in the hydro pressure resulted in increased bursting strength, tensile strength and flexural rigidity of the fabric. The heavier fabrics showed higher tensile strength. In another study, Ghassemieh et al (146), investigated that desirable fibre entanglement was dependent on the fibre, web properties and on the water jet pressure.

The tensile properties of hydroentangled nonwoven fabric depends on several factors such as:

- Fibre count and fibre length
- Fibre orientation percentage in the web
- Hydro pressure (entanglement behaviour of fibres)
- Manufacturing processes

The tensile behaviour of hydroentangled nonwoven fabrics mainly depends on their microstructures that are changed with the change in the hydro pressure, because when the hydro pressure is increased the thickness of the fabric and the arrangement

of the fibres in the assembly are changed and these factors directly affect the tensile properties of the nonwoven fabric. Komori et al (137) studied the microstructure of nonwoven fabrics and found that the main structural parameters such as orientation, fibre crimp and elasticity of the fibres have major effect on the mechanical properties of the hydroentangled nonwoven fabrics. The tensile behaviour of nonwoven fabrics produced at different hydro pressures is discussed in the following sections.

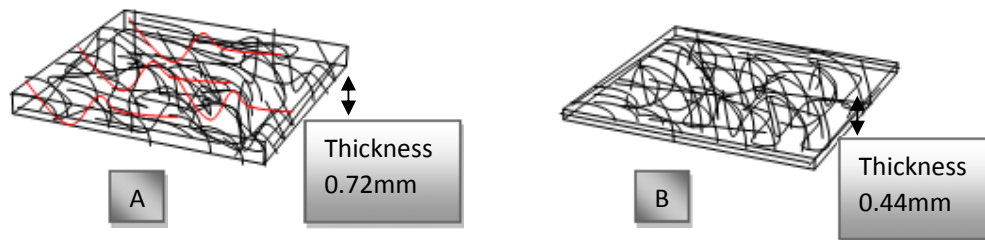
#### **4.2.9.1 Effect of hydro pressure on the tensile strength of hydroentangled fabrics (S1 to S4)**

The results presented in Figure 4.46 demonstrate that the strength of the hydroentangled fabric gradually increased as a result of the increasing water jet pressures. Fabric produced at 50 bars hydro pressure had tensile strength of 0.026 Ntex<sup>-1</sup> in MD and 0.007 Ntex<sup>-1</sup> in CD, but when pressure was increased from 50 bars to 75 bars then tensile strength of the fabric was increased by 57% in MD and 85% in CD that was 0.041 Ntex<sup>-1</sup> and 0.013 Ntex<sup>-1</sup> respectively. It was because of the better entanglement of the constituent fibres, better twisting of the fibres and also due to the enhancement in the bending and rotation of the fibres around themselves and other fibres in the form of interlocking.

At 50 bars hydro pressure, the intensity of the pressure was very low, it was not enough to force the fibre to entangle with its surrounding fibres to create a strong mechanical bonding, therefore there were spaces between the fibres that caused the lower strength of the fabric. On the other hand, when pressure was increased to 75 bars then, the fibres were closely entangled with their surrounding fibres through frictional forces thus resulting in the enhancement of the tensile strength of the fabric both in the MD and the CD directions. The most important factor that plays a predominant role in the mechanical behaviour of the nonwoven hydroentangled fabrics is friction due to which a fibre hold its surrounding fibres firmly and that enhances the tensile properties of the fabric. Secondly, very fine fibres were used to produce these hydroentangled nonwoven fabrics and according to Sanjoy et al (116), fine fibres bend easily that gives more compact structure and higher surface area resulting in better interlocking of the fibres.

When pressure was increased from 75 bars to 100 bars then it can be noticed that the tensile strength was increased but the effect was not as pronounced. Mao and Russell

(9) also noticed in their research that the initial increase in the hydro pressure the tensile strength of the fabric increased significantly, however, any further increase in hydro pressure or specific energy results brought about comparatively smaller increase in the tensile strength. These researchers also found that further increase in the energy of the hydroentanglement process may cause a decrease in the tensile strength because of the degradation of the fabric structure. By increasing the hydro pressure from 75 bars to 100 bars a slight increase in the tensile strength of the fabric in both in the MD the CD strength, was obtained. This small incremental change in the tensile strength in machine and cross direction was because of the fabric structures. At 75 bars, the fabric already had a compact structure so that when the pressure was increased to 100 bars only a slight increase in the fabric compactness and the orientation of fibres in the fabric structure occurred, thus leading to a slight increase in the tensile strength of the fabric produced. Therefore, when the hydroentanglement pressure was increased the thickness of the fabric was reduced, resulting in a more interlocked structure fabric as illustrated in Figure 4.45.

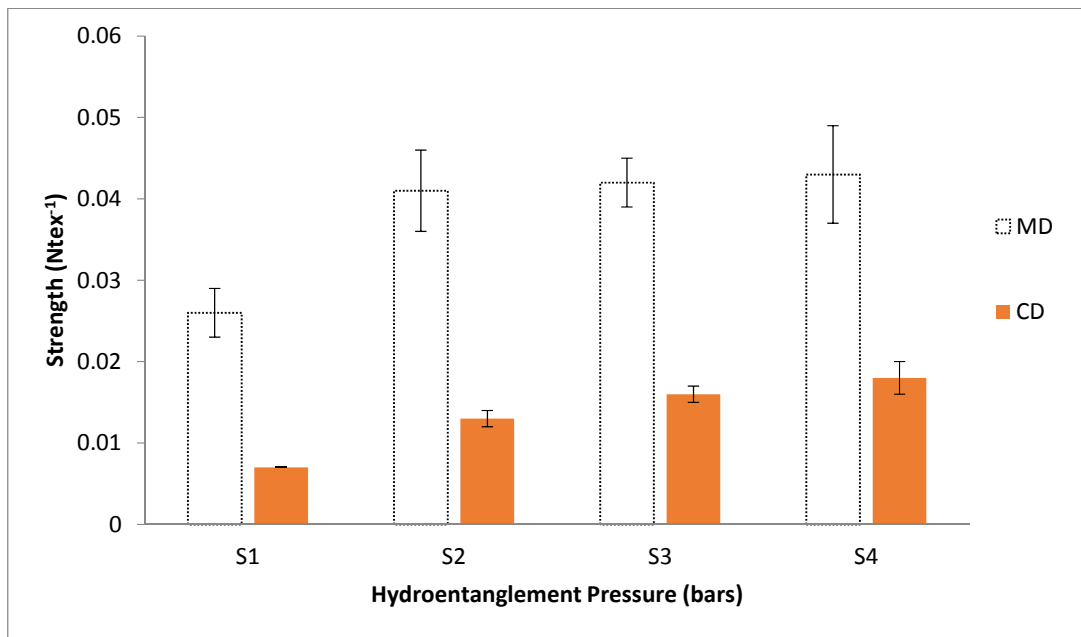


**Figure 4.45** Effect of hydroentanglement pressure on thicknesses of nonwoven fabric

Figure 4.45 shows that fabric A produced at 50 hydroentanglement bars pressure exhibited 0.72 mm thickness because of its thick structure fibres were slightly entangled and there were more spaces between the fibres that resulted in low mechanical bonding between the fibres due to which the fabric produced at 50 bars exhibited lower tensile strength in the machine and the cross machine directions. When pressure the hydroentanglement pressure was increased to 75 bars then the fabric thickness was reduced to 0.44 mm, which gave more compact structure and because of compactness more fibres were interlocked with each other and were also entangled with their neighbouring fibres, thus resulting in the enhancement of the tensile strength of the fabric. Therefore it may be concluded that the higher hydroentanglement pressure reduces the thickness of the fabric, which has a direct

effect on the tensile properties of the fabric produced. The same phenomenon is observed when the hydro pressure was increased from 100 bars to 125 bars, i.e. an increase in the hydro pressure resulted in a more compact fabric structure.

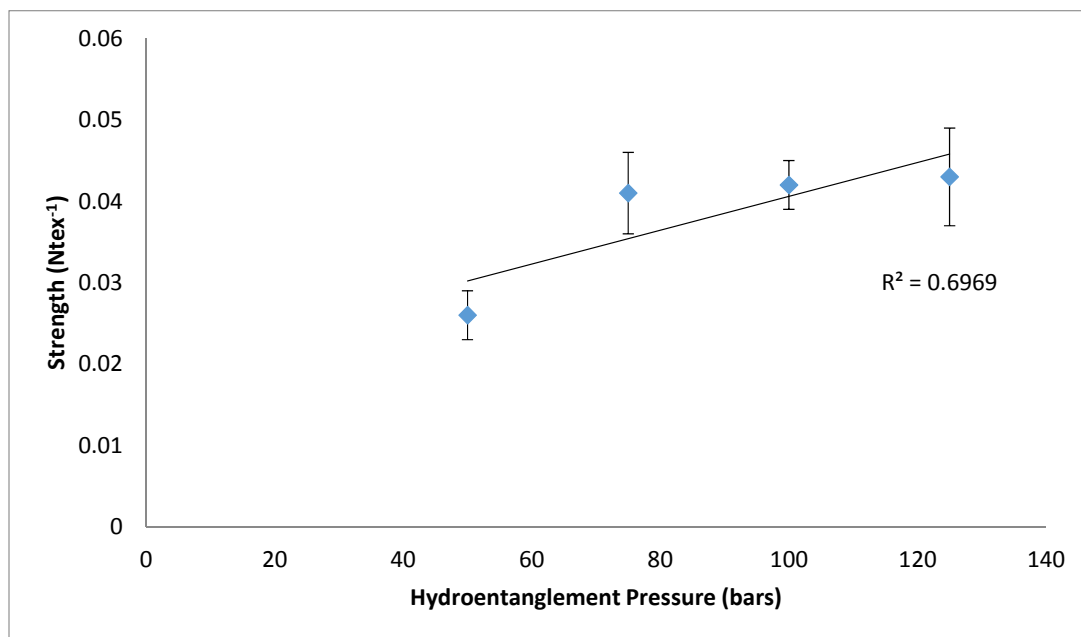
The results presented in Figure 4.46 show that the tensile strength of fabric is higher in the MD than the CD. It probably more fibres were aligned in the MD rather than the CD of the fabric. Therefore, when the hydro pressure was increased most of the fibres were entangled in the MD and fewer were entangled in the CD, resulting in the lower tensile strength of the fabric in the CD.



**Figure 4.46** Effect of hydro pressures on the tensile strength of the hydroentanglement fabrics produced through needlepunched process.

Figure 4.46a, shows that the tensile strength of the fabric was increasing as the hydroentanglement pressure was increased from 50 bars to 125 bars. Seyam et al (61) found that hydroentangling energy has a significant effect on the mechanical properties of the hydroentangled nonwoven fabrics, an increase in the energy of the process increases the mechanical performance of the fabric. There are strong positive relation between hydro pressure and the tensile strength of the fabrics. Mao and Russell (62) also found that water pressure and specific energy influence of tensile properties of hydroentangled fabrics.





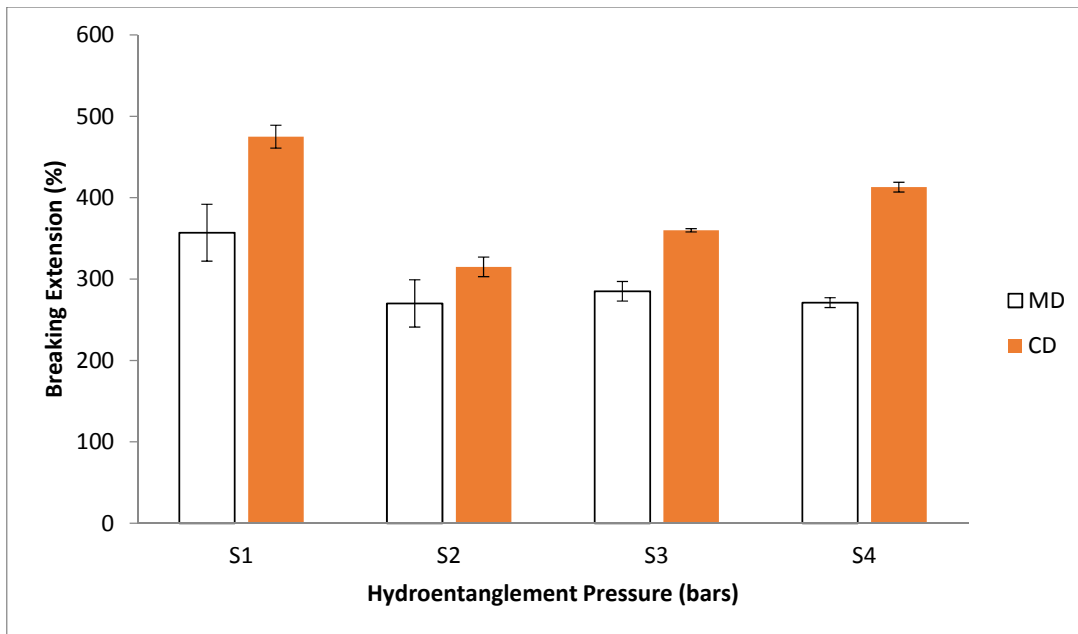
**Figure 4.46a** Correlation between hydro pressure and tensile strength of the fabrics in MD

At 75 bars pressure, fabric showed much higher strength, which was almost 57% higher than the tensile strength of the fabric that was produced at 50 bars hydroentanglement pressure but after that at 100 bars pressure fabric exhibited only slightly higher tensile strength in the MD. Similar results were obtained when the hydroentanglement pressure was increased from 100 bars to 125.

#### **4.2.9.2 Effect of hydro pressures on the extensibility of the hydroentangled fabric**

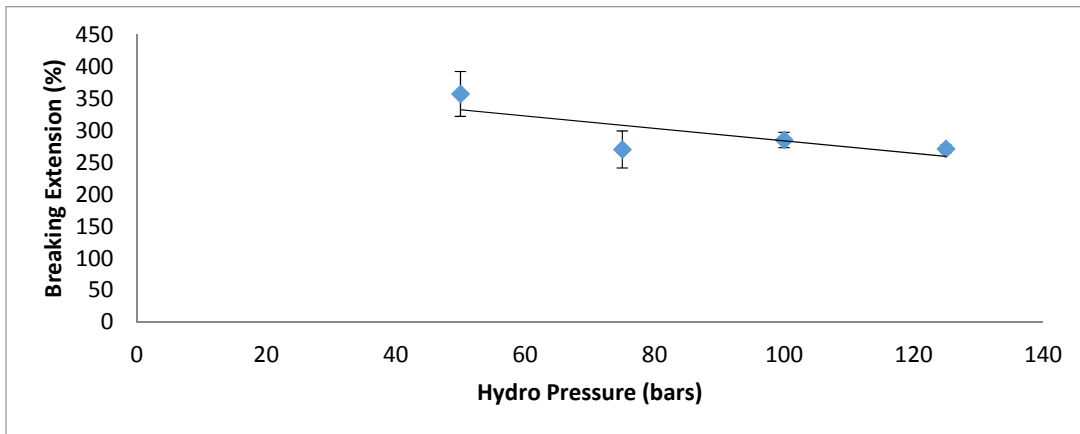
It has been noted that when the hydro pressure was increased from the lower to the higher values, the extensibility of the hydroentangled fabrics produced was initially decreased then an increase was observed, particularly in the CD. The fabric produced at 50 bars hydro pressure exhibited higher extensibility in machine and cross direction, but when pressure was increased to 75 bars then the extensibility was reduced from 357% to 270% in the MD and from 475% to 315% in the CD, as shown in Figure 4.46b. This change was because of the fibres arrangement and the fibres entangling behaviour within the structure of the fabrics. Fabric produced at 50 bars was loosely entangled and had more space between the fibres due to which it showed higher extensibility in both directions.

However, when pressure was increased from 50 bars to 75 bars then the extensibility of the fabric was decreased by 24% in the MD and 37% in the CD. This was due to the increase in the compactness of the fabric structure in which the fibres are more firmly entangled and rearranged. At the higher pressure fibres do not have enough space and freedom of movement within the fabric structure. When pressure was increased from 75 bars to 100 bars, a slight incremental change in the extensibility in the MD was observed. However, when the hydro pressure was increased from 100 bars to 125 bars then a small decrease in the MD (5%) and an increase in the CD (15%) in the extensibility of the fabric was obtained.



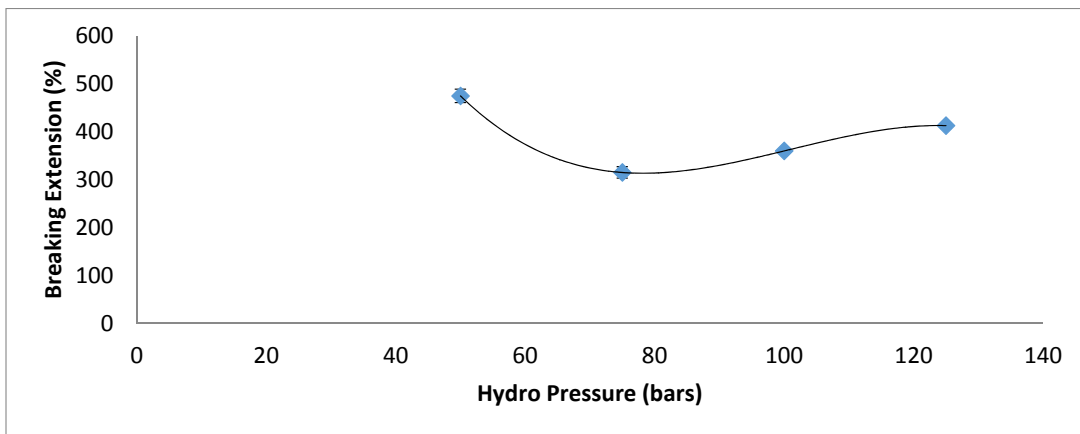
**Figure 4.46b** Effect of hydro pressures on the extensibility of the fabrics produced through hydroentanglement-needlepunched process

Figure 4.46c demonstrates that with the increasing the pressure the extensibility was decreased in the MD. This is mainly due to the enhancement in the mechanical bonding between the fibres as the hydro pressure was increased from the lower to the higher value. Furthermore, very fine dtex fibres were used for the production of the nonwoven fabrics, which led to the presence of more number per unit area of the fabric, thus restricting the movement of the fibres in the in MD.



**Figure 4.46c** Correlation between hydro pressure and extensibility of the fabrics in MD

However, the results presented in Figure 4.46d show that there is no direct relationship between the breaking extension and the breaking strength of the fabric in the CD. The breaking extension of the fabric in the CD was initially reduced as the breaking strength of the fabric was increased, however, any further increase in the hydro pressure resulted in an increase in the breaking extension. This appears to be due to the enhancement in the compaction of the fabric structure and fibre slippage at very high values of hydro pressure.



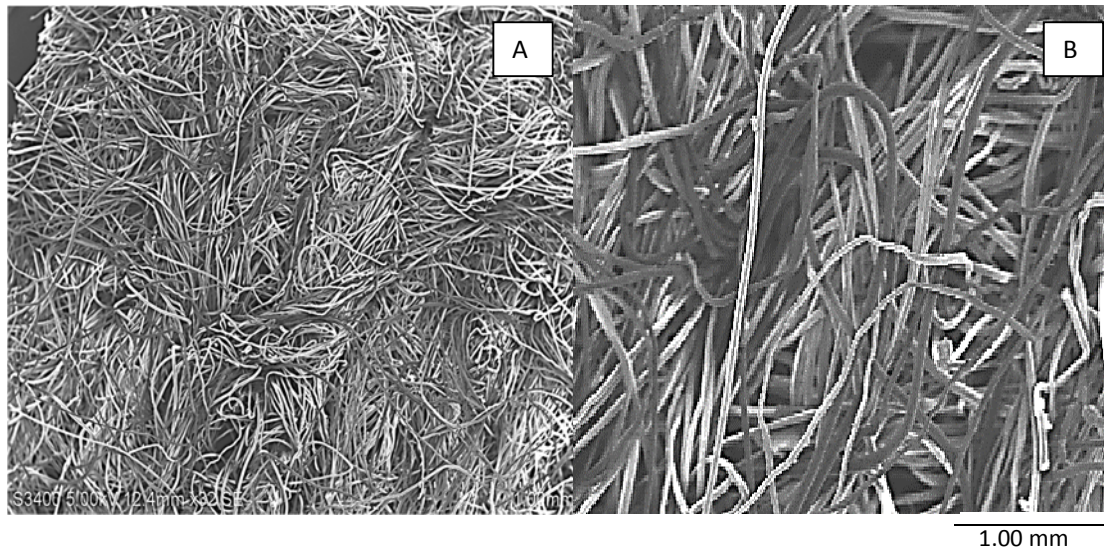
**Figure 4.46d** Correlation between hydro pressure and extensibility of the fabrics in CD

At 50 bars hydro pressure the fibres were not highly entangled due to which the inter fibre bonding was weak and the fabric extended easily with application of the tensile force. However, entanglement of the fibres in the fabric produced at the higher hydro

pressure (75 bars) was more intense, which resulted in a more compact and stronger structure. As a result movement of the fibre was restricted giving fabric with lower extensibility.

#### 4.2.9.3 Hydroentangled fabric produced at 50 bars (S1)

Sample S1 exhibited lower tensile strength but higher elongation as shown in Figure 4.48. At this pressure the extent of fibre entanglement was low and therefore when a tensile load was applied to the fabric the fibres easily disentangled and the fabric integrity was lost. Figure 4.47 depicts the SEM images of the fabric at two magnifications. Figure 4.47b is the magnified image of the S1 fabric, which shows that the fibres are loosely entangled within the fabric and this allowed the fibres to move freely in the machine and cross machine directions on the application of a tensile force. This means that the fibres could easily slip past each other thus resulting in low tensile strength and high elongation values, furthermore, the crimped structure of the bicomponent fibres contributed to the higher extensibility of the fabric produced (Figure 4.48).

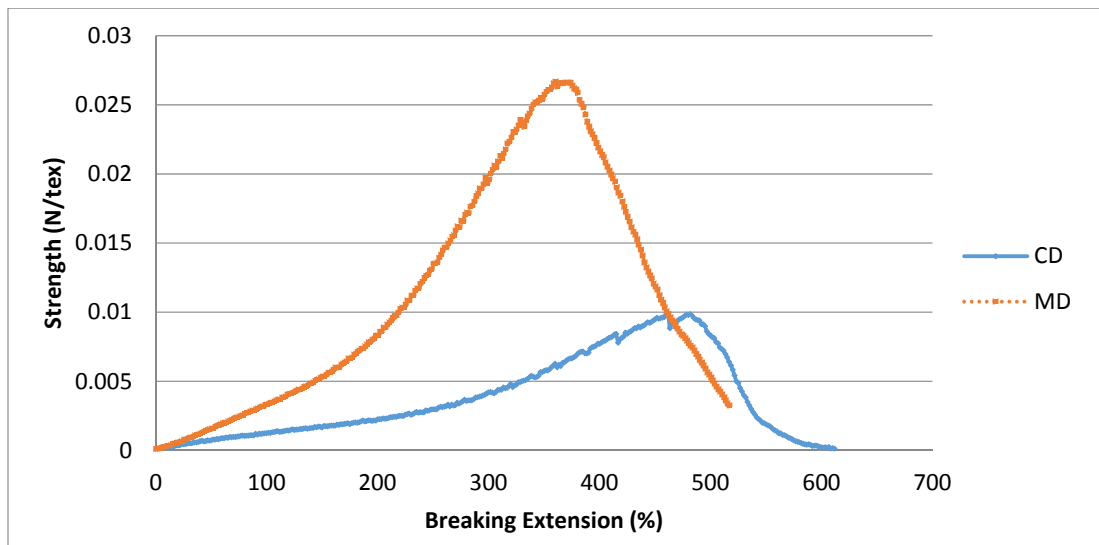


**Figure 4.47** Scanning Electron Microscope (SEM) images showing the hydroentangled nonwoven fabric produced at 50 bars

At the low hydro pressure, fibres were mainly arranged in the MD and because of the lower intensity of water pressure, the reverse force of water was low and this resulted in low level of fibre entanglement within the fabric structure. Furthermore, Mao and Russell (62) found that the applied energy introduced to the web during hydroentanglement process is consumed in various ways, such as, energy losses by

adsorption by standing water in the web, compression of web, deformation of the fibres, frictional forces of the fibres, etc. So the remaining energy at 50 bars hydro pressure was not enough to entangle the fibres the same extent as at the higher hydro pressure.

Figure 4.47 shows that the fibres were not highly entangled although they appear to be condensed and because of needlepunching the number of fibres per unit area of the fabric were reduced. Furthermore, the fibres are more condensed in the MD than in the CD and there are not many spaces between the fibres in the MD to allow free movement of the fine fibres. The count of bicomponent fibre was 2.2dtex and the count of Tencel fibre was 1.4 dtex, consequently there were more fibres per unit area of the fabric. This resulted in the lower extension and higher tensile strength values of the fabric in the MD as compared to the CD, as illustrated in Figure 4.48.

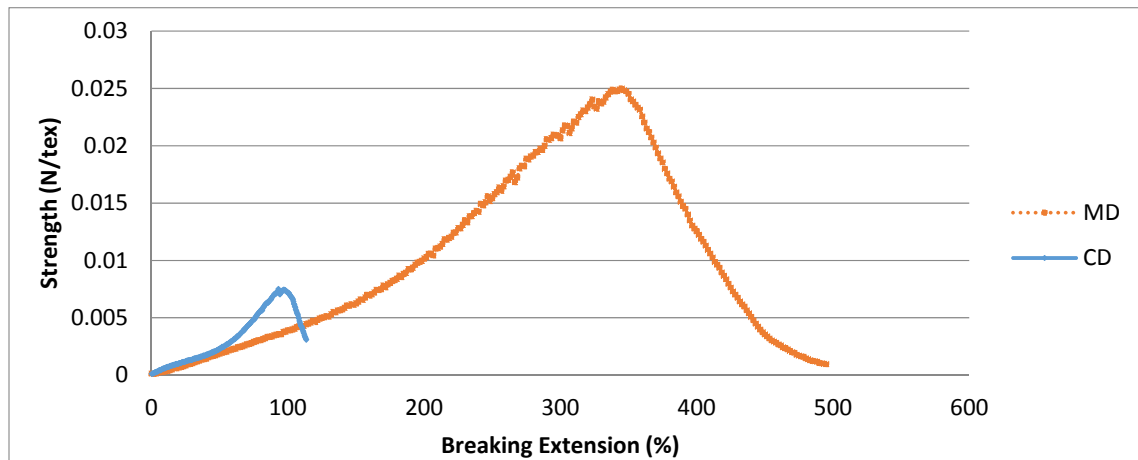


**Figure 4.48** Effect of 50 bars hydro pressure on the tensile properties of the hydroentangled nonwoven fabric S1.

The extensibility of this sample was 357% in MD and 478% in CD. This highly extensibility was because of the free movements of the fibres within the structure of the fabric. As it has been discussed earlier that at 50 bars hydro pressure the fibres were not firmly entangled, which also enhanced the extensibility of the fabric. The fabric exhibited higher extensibility in the CD than in the MD due to the presence of more space between the fibres within the fabric in the CD.

#### **4.2.9.3.1 Effect of thermal finishing process on hydroentangled nonwoven fabric produced at 50 bars pressure (S5)**

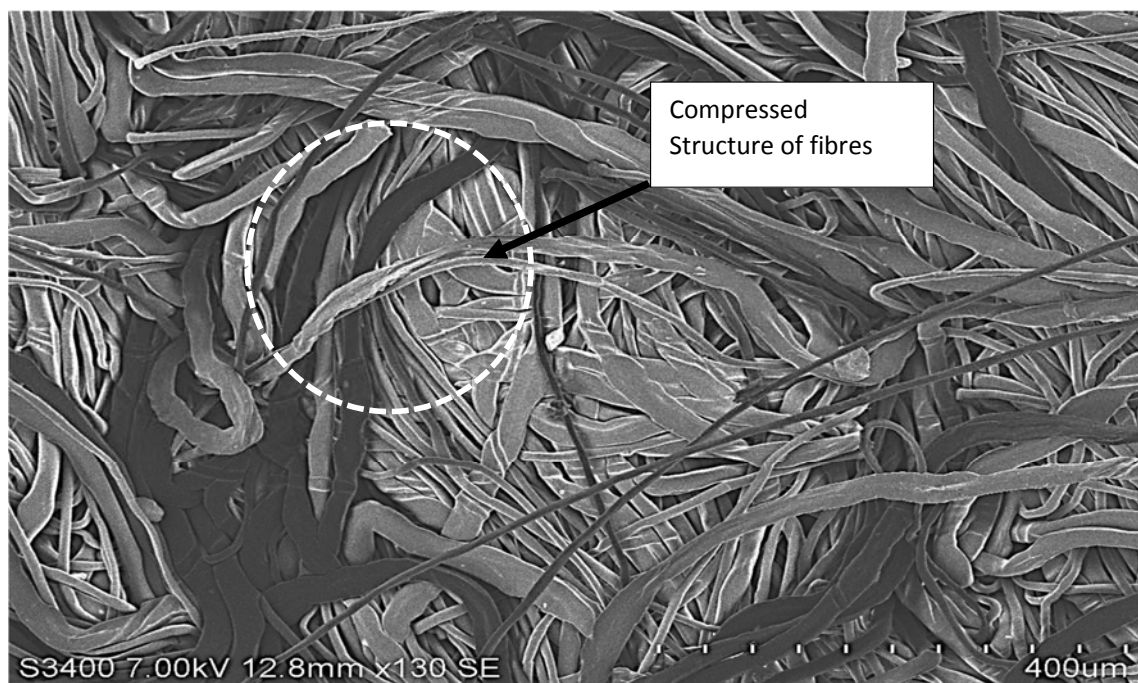
Figure 4.48a shows tensile properties of the hydroentangled nonwoven fabric S5 after it was subjected to the thermal process. The fabric was produced by using 30% of bicomponent sheath/core (PE/PET) fibres and 70% Tencel fibres. When the fabric was subjected to the thermal finishing process, the sheath part of the bicomponent fibre (PE) melted and created thermal bonding with its surrounding fibres and because of the heat, fibres were shrunk that directly affected the tensile properties of the fabric. Due to the low level of fibre entanglement in S5 fabric, there were more spaces between the fibres and the fact that the fibres were shrunk, this reduce the tensile strength both in the machine and cross directions. However, the change in the tensile strength of the fabric, both in the CD and MD, was very small, although the breaking extension in the CD exhibited a considerable decrease as can be seen in Figure 4.48a. After thermal processing the extensibility of the fabric was reduced by 6% in the MD and 81% in the CD.



**Figure 4.48a** Effect of thermal bonding process on the tensile properties of the hydroentangled nonwoven fabric S5.

#### **4.2.9.3.2 Effect of calendaring process on hydroentangled nonwoven fabric produced at 50 bars pressure (S9)**

The hydroentangled fabric produced at 50 bar hydro pressure was finished with the calendaring process and then tested for its tensile properties. The results illustrated in Figure 4.49a show a notable increase in the tensile strength of the nonwoven fabric both in the machine and cross directions as compared with S5 and S1 samples.



**Figure 4.49** Optical microscopic view of calendared fabric S9 produced at 50 bars hydro pressure

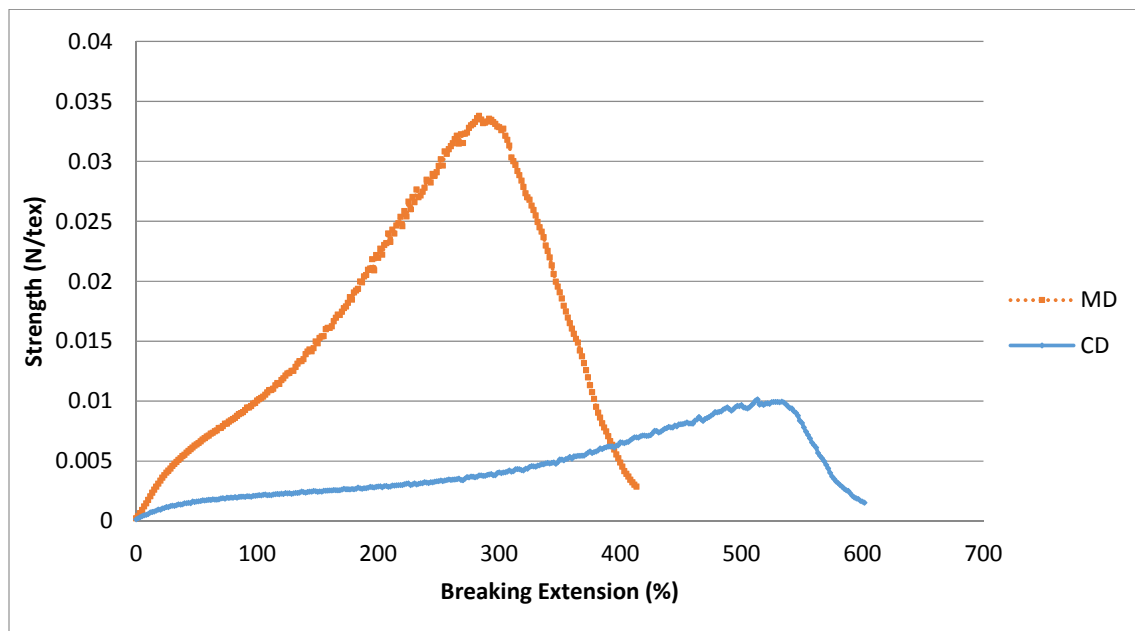
The increase in the tensile strength was 27% in the MD when compared with the non-calendared sample and 37% increase compared to the thermal bonding process. The increase in the tensile strength of the fabric in the CD due to the calendaring process was nominal, but the tensile strength of the calendared fabric was 28% higher than the thermally bonded fabric. During the calendaring process, because of pressure rollers (110°C with 1 ton pressure), the melted sheath part of bicomponent fibre was forced to create thermal bonding between the fibres without any fibre shrinkage. This was the main reason that the calendared sample S9 showed higher tensile strength in MD than the thermally bonded sample.

The combination of the increased temperature and the applied pressure melted the low melting (PE) part of the bicomponent fibre that penetrated into the body of the fabric, imparting rigidity to the structure of the fabric. The structure of the calendared fabric is presented in the form of an optical image (Figure 4.49), which shows that the fibres are bonded together and there are no spaces between the fibres and this bonding between the fibres caused the observed increase in the tensile strength, both in the machine and cross directions. The increase in the tensile strength was accompanied by a decrease in the extensibility of the fabric. In the machine direction



the extensibility of the calendared sample was decreased by 22% and the tensile strength was increased by 17%. However, the changes in the tensile properties of the calendared fabric were very small in the CD and were similar to the untreated fabric. The thermally bonded fibres have greater ability to stretch and can lead to fabrics with more stretch in the CD.

Calendared sample exhibited almost 500% more stretch in the CD compare to the thermally bonded sample, as shown in Figure 4.48a and 4.49a. The higher value of extensibility of the calendared sample was due to the lower shrinkage of fibres because of the use of pressure rollers for creating the bonding between the fibres.



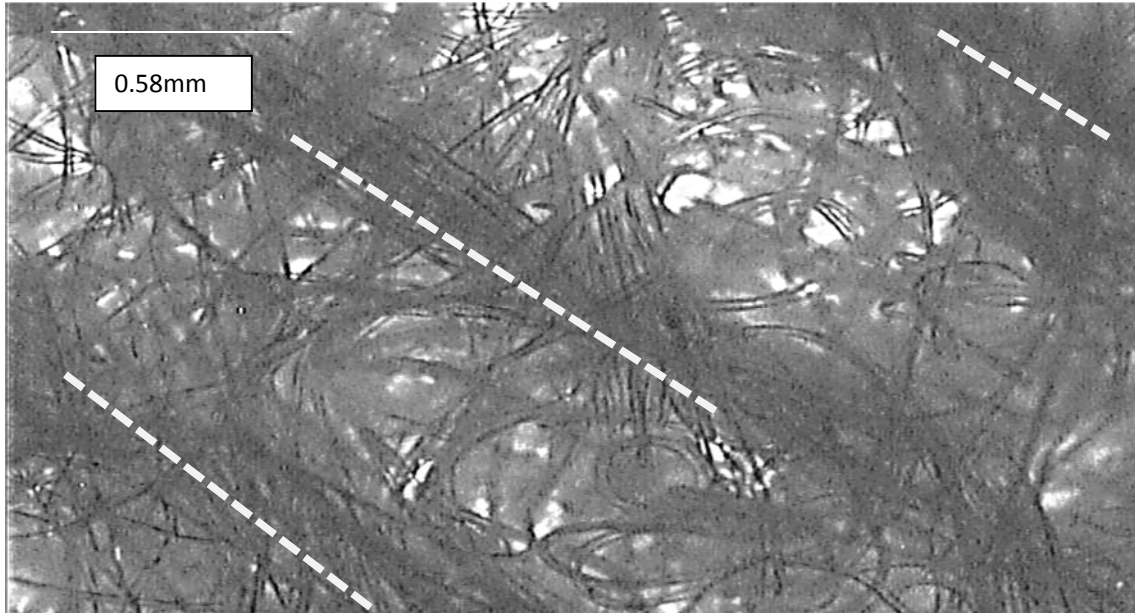
**Figure 4.49a** Effect of calendared process on the tensile properties of the hydroentangled nonwoven fabric S9.

#### 4.2.9.4. Tensile properties of hydroentangled fabric S2 produced at 75 bars pressure

The nonwoven fabric S2 produced at 75 bars hydro pressure exhibited higher tensile strength in the MD and the CD as compared to the fabric produced at the lower hydro pressure, but it showed lower elongation values in the machine and cross directions. This is because of the greater entangling of the fibres in the machine and cross directions and fibres were more aligned in the MD. Furthermore, greater number of fibres per unit area of the fabric were present as shown in Figure 4.50. Strands of the

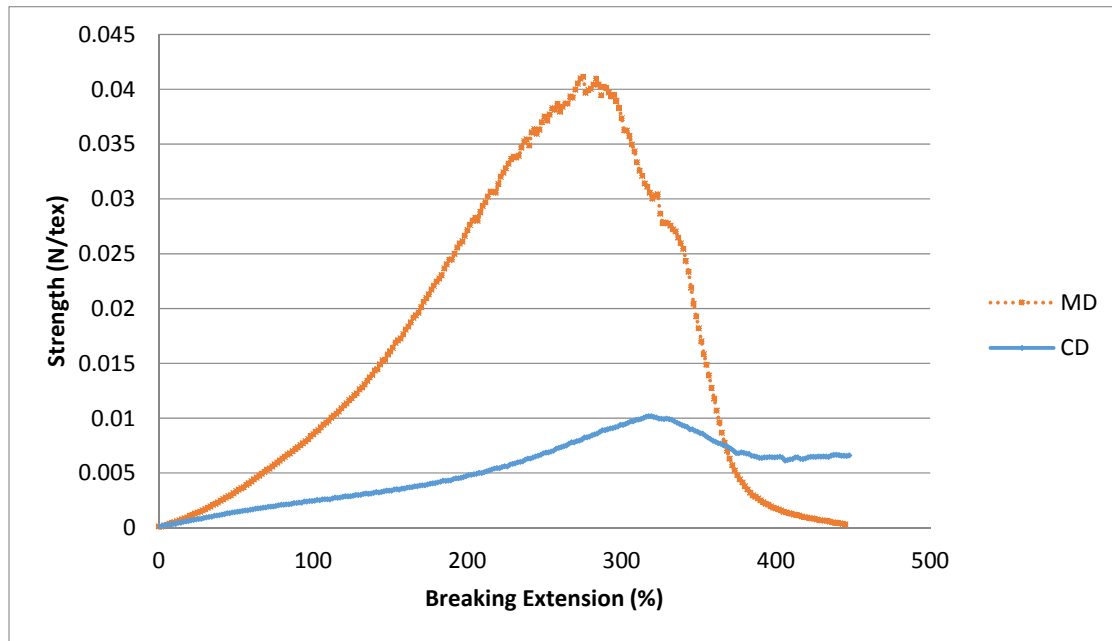


fibres can be seen (Figure 4.50), which were not visible in the fabric produced at 50 bar hydro pressure. These strands are formed due to the better entanglement and alignment of the fibres in the fabric at the higher hydro pressure.



**Figure 4.50** Optical microscopic image of hydroentangled nonwoven fabric S2 produced at 75 bars hydro pressure.

Figure 4.50a shows that the tensile strength of the hydroentangled nonwoven fabric produced at 75 bars hydro pressure increased by 57% in MD and 85% in CD as compared to the fabric produced at 50 bars hydro pressure. It was because of the better entanglement between fibres due to the increased intensity of the hydro pressure. The web was more condensed due to which more fibres were present per unit area of the fabric, thus contributing to the better entanglement of the fibres in the fabric structure. These factors enhanced the tensile strength of the fabric both in the machine and cross directions, accompanied by a decrease in the elongation, as shown in Figure 4.50a. It may be concluded that by increasing the water pressure the strength of the fabric can be increased. However, the elongation of the fabric is reduced due the restricted movement of the fibres in the fabric structure. The restricted movement of fibres was because of the strong mechanical bonding between the fibres in form of twisting around and entangling with their surrounding fibres in the machine and cross directions.



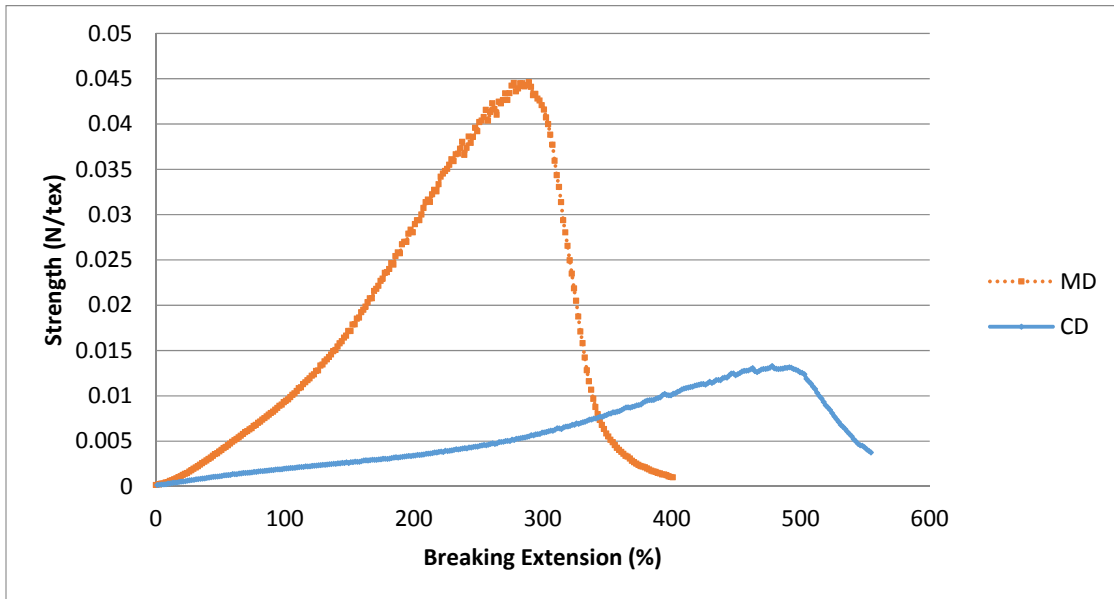
**Figure 4.50a** Effect of 75 bars hydro pressure on the tensile properties of the hydroentangled nonwoven fabric S2

**4.2.9.4.1. Effect of thermal bonding on the tensile properties of hydroentangled nonwoven fabric S6 produced at 75 bars**

The hydroentangled nonwoven fabric S6 produced at 75 bars hydro pressure was further processed by using the thermal process in order to improve the tensile strength of the fabric in the MD and CD. Fibres in the fabric S2 structure were better entangled than the fabric S1 produced at 50 bars hydro pressure. Furthermore, the fibres were aligned in the form of strands due to which the spaces between the fibres were reduced and a more compact structure was obtained. However, the thermal finishing resulted in little improvement in the strength of the fabric S6. The enhancement in the strength was 10 % and 30 % in the MD and CD, respectively (Figure 4.51). Now there were two bonding forces in the fabric, first was the mechanical bonding of fibres in term of twisting and second was the thermal bonding that was created by melting the sheath part of the Bicomponent fibres. These were the reason that enhanced the tensile strength of the fabric in the machine and cross directions.

However, the elongation values were also increased by 52% in the CD and there were no noticeable change in extensibility in MD after the thermal process, when compared with the hydroentangled nonwoven fabric produced at 75 bars hydro pressure. When

the fabric was stretched then, because of better entangling of the fibres and strong thermal bonding, fibres needed more strength to split from its surrounding fibres that caused to enhance the elongation capability of the fabric in the cross direction.

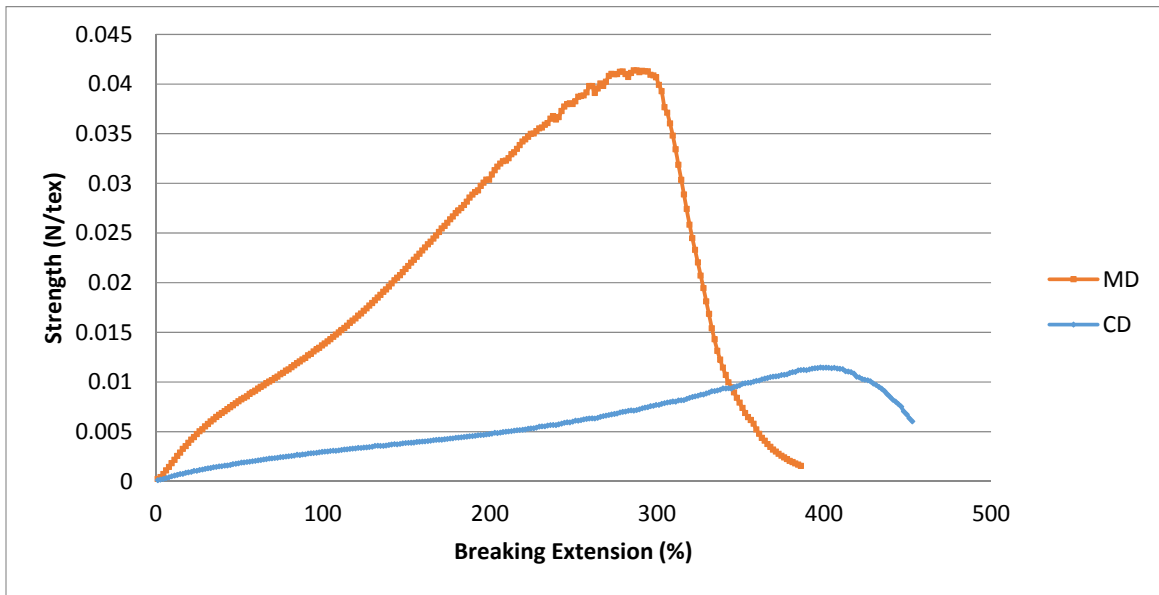


**Figure 4.51** Effect of thermal process on the tensile properties of the hydroentangled nonwoven fabric S6 produced at 75 bars hydro pressure.

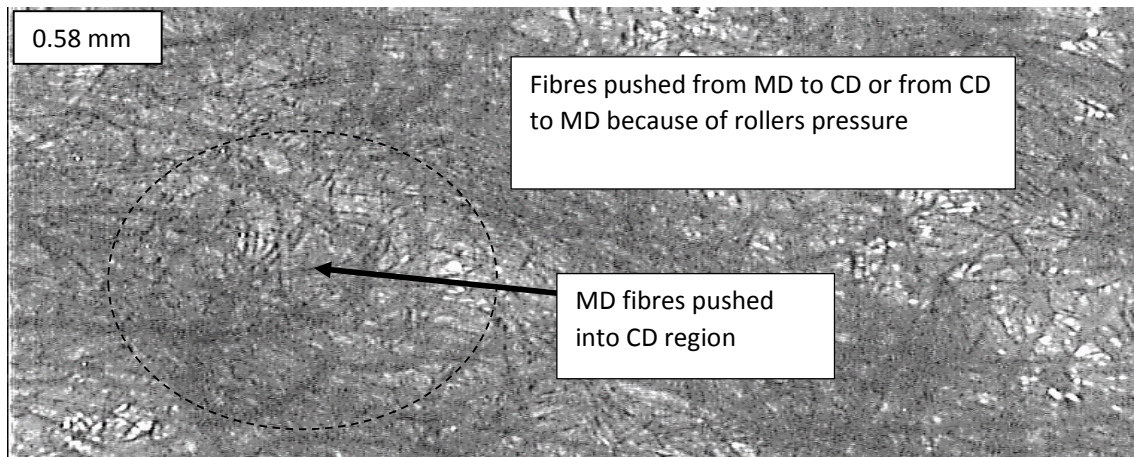
#### ***4.2.9.4.2. Effect of calendaring process on hydroentangled nonwoven fabric S10 produced at 75 bars pressure***

During the calendaring process heat and pressure are exerted on the fabric simultaneously and as a result the low melting part of the bicomponent fibres penetrated into the structure of the fabric and gave the stiffening effect to the fabric, which also had an impact on the tensile strength of the fabric. Because of the high pressure (1 ton), some fibres were damaged due to which the tensile strength was reduced both in the MD (7%) and the CD (15%), as compared to the thermally bonded fabric (Figure 4.52). The calendaring process also gave lustre to the fabric surface because the small protruding fibres on the surface were fused together due the heated pressure rollers. This resulted in the smooth surface where the light is reflected in the form of shine. Normally, the calendaring process restricts the fibre movement in the fabric region that affects the extensibility of the fabric but in this case, there were no significant changes observed in the elongation values in MD as compared to the uncalendared fabric produced at 75 bars hydro pressure. This was because of the

presence of the spaces between the fibres that prevented the formation very strong bonding between the fibres.



**Figure 4.52** Effect of calendaring process on the tensile properties of the hydroentangled nonwoven fabric S10 produced at 75 bars hydro pressure.



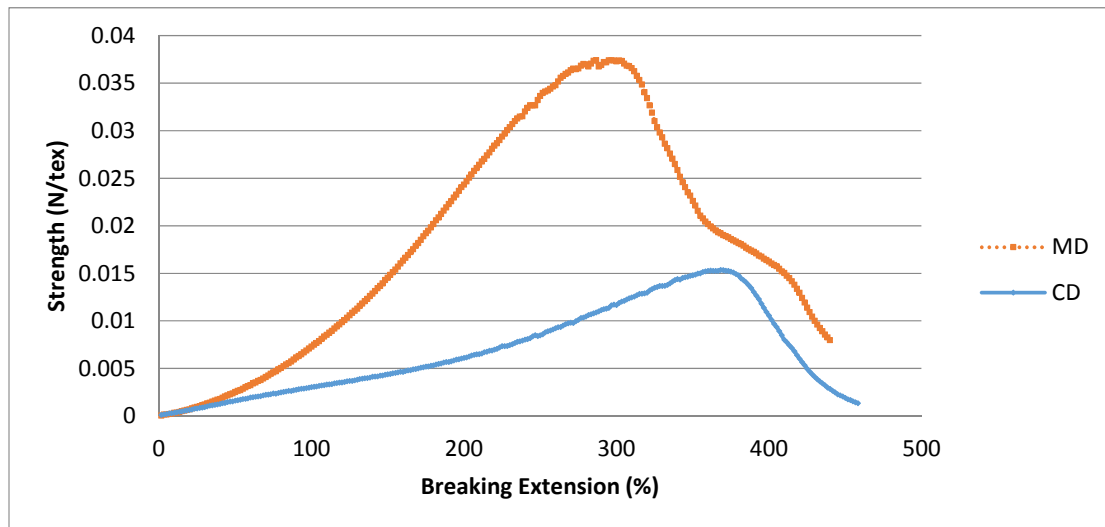
**Figure 4.52a** Optical microscopic picture of hydroentangled calendared processed nonwoven fabric

It can be observed in Figure 4.52a that due to the roller pressure some fibres migrated from the machine direction to the cross direction region and restricted the fibre movement in the cross direction region that led to the reduction the breaking extension of the calendared fabric by 17% in the CD, as shown in Figure 4.52.

#### 4.2.9.5. Hydroentangled fabric produced at 100 bar pressure (S3)

Hydroentangled nonwoven fabric S3 produced at 100 bars hydro pressure exhibited higher tensile strength than the hydroentangled fabric produced at 50 bars hydro pressure as shown in Figure 4.53. The enhancement in the strength was due to the better alignment and entanglement of the fibres in the machine direction.

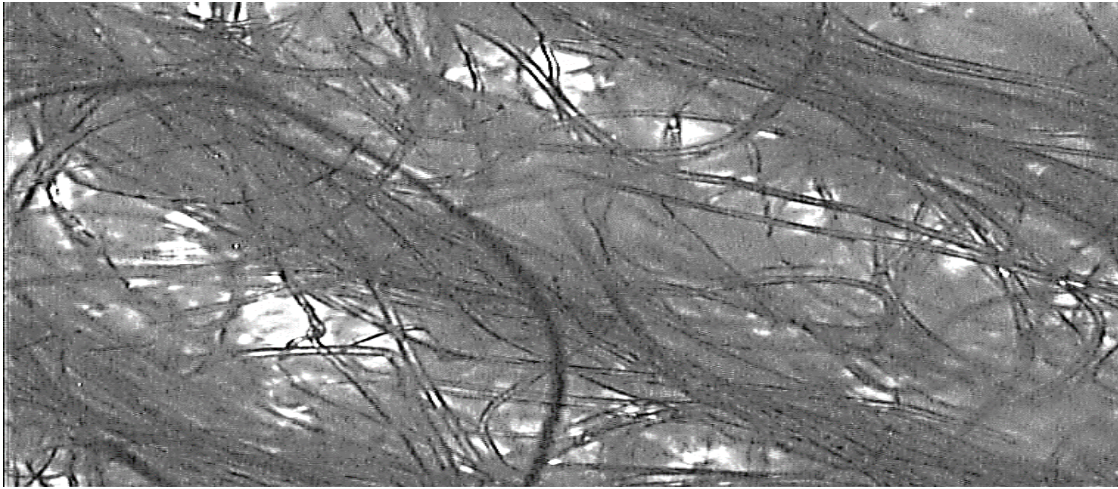
It can be seen in Figure 4.53a that mostly fibres were aligned in the MD and are shown as strand or yarns in the structure of the fabric. This was due to the higher intensity of the water pressure that entangled fibres more strongly than the fabrics produced at 50 bars hydro pressure. Hydroentangled nonwoven fabric produced at 100 bar pressure exhibited 42% higher strength in the MD and 66% higher strength in the CD as compared to the hydroentangled nonwoven fabric produced at 50 bars hydro pressure. However, as expected, the breaking extension of this nonwoven fabric was reduced by 21% in the MD and reduced by 24% in the CD as compared to the nonwoven fabric produced at 50 bars hydro pressure. Once again this could be related to the restriction of the fibre movement within the fabric structure.



**Figure 4.53** Effect of 100 bars hydro pressure on the tensile properties of the hydroentangled nonwoven fabric S3

The fabric S1 produced at 50 bars hydro pressure was loosely entangled and there were more spaces available between the fibres that allowed free movement of the fibres in the fabric. But the fabric S3 produced at 100 bars hydro pressure exhibited

lower breaking extension, because the fibres were tightly entangled and the spaces between the fibres were limited that restricted the fibre movement in the fabric region.



0.58 mm

**Figure 4.53a** Optical microscopic image of hydroentangled nonwoven fabric S3 produced at 100 bars hydro pressure.

The results presented in Figure 4.53 also show that the MD strength value was 7% lower than the fabric produced at 75 bars hydro pressure and 50% higher in the CD. This was due to the changes in the structure of the fabric produced at 100 bar hydro pressure. At 100 bars pressure, because of high intensity of water, the fibres were slightly scattered and moved to the cross direction region from the machine direction and secondly the fibres in the MD also created a strong bonding with the fibres in the CD, as shown in Figure 4.53.

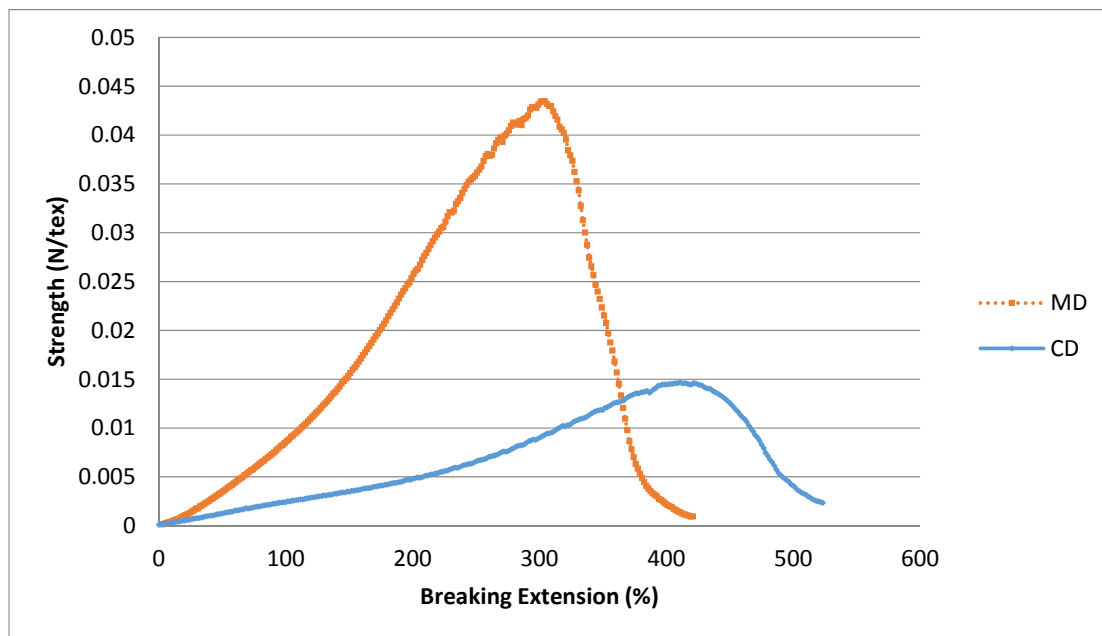
Hydroentangled fabric produced at 100 bars exhibited almost the same breaking extension in the MD as the fabric produced at 75 bars hydro pressure but, it showed 15% higher breaking extension in the CD. There appear to be two main reasons for this; firstly, the higher entanglement of fibres in the CD and secondly, the increase in the number of fibres per unit of the fabric in the cross direction region. It may be concluded that the hydroentangled fabric produced at 100 bars hydro pressure exhibited good tensile and breaking extension that can meet the requirements for clothing applications.



#### 4.2.9.5.1. Effect of thermal bonding on the tensile properties of hydroentangled nonwoven fabric S7 produced at 100 bars

Hydroentangled nonwoven fabric produced at 100 bars hydro pressure was finished by using the thermal process in order to enhance the tensile strength of the S7 fabric. The results presented in Figure 4.54 demonstrate that the tensile strength was increased by 16% and breaking extension also was increased by 6% in MD. It was because of the compact structure of the fabric, which allow more thermal bonding between the fibres to take place in the MD. However, there were no significant changes in the tensile strength of the fabric in the CD because of the lower number of bicomponent fibres were present in the MD region and also there were more space between the fibres that limited the extent of thermal bonding between the fibres.

The breaking extension of the fabric S7 in the CD, after thermal processing, was enhanced by 13% (Figure 4.54) as compared to the hydroentangled nonwoven fabric produced at 100 bars hydro pressure. It was because of the high strength in the machine direction region that support the cross direction in resisting the disentangling of the fibres, which enhanced the extensibility of the fabric in CD after the thermal bonding process.



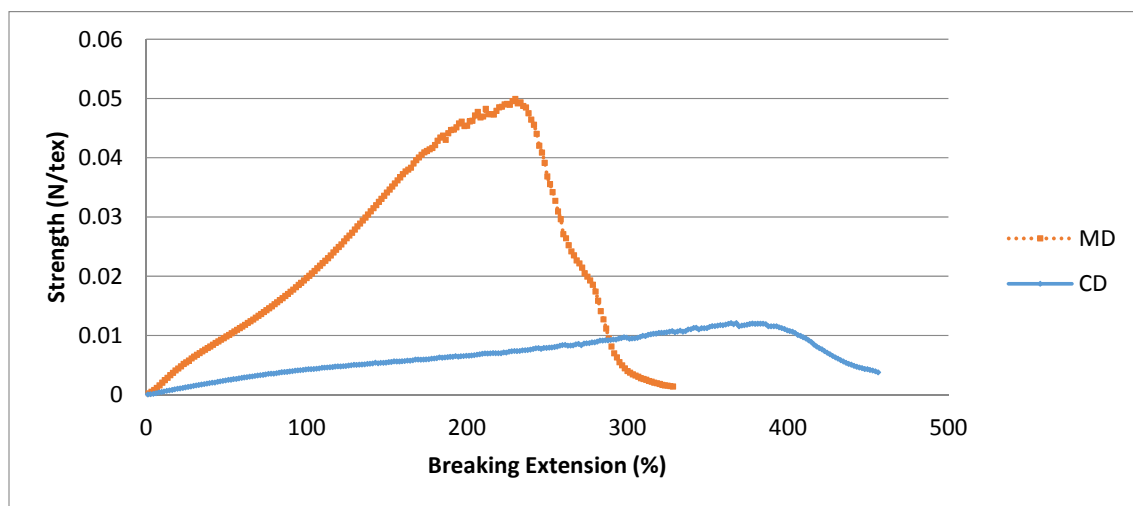
**Figure 4.54** Effect of thermal process on the tensile properties of the hydroentangled nonwoven fabric S7 produced at 100 bars hydro pressure.

#### 4.2.9.5.2 Effect of calendaring process on the tensile properties of hydroentangled nonwoven fabric produced at 100 bars (S11)

The results presented in Figure 4.55 show that the hydroentangled nonwoven fabric S11 produced at 100 bar pressure exhibited 29% higher tensile strength in the MD after undergoing the calendaring process, as compared with the non-calendared hydroentangled fabric produced at 100 bars hydro pressure. It also showed 12% higher strength in MD, as compared with thermal processed sample.

The higher strength of the calendared sample S11 was because of the strong entanglement of the fibres and the creation of strong thermal bonding of the melted sheath part (PE) of bicomponent fibres with the neighbouring fibres, which created a cohesiveness fabric structure in the MD. However, nearly 22% reduction in the breaking extension of the fabric in the MD was also observed as compared to the non-calendared hydroentangled fabric and 26% reduction in breaking extension as compared with the thermally processed fabric.

After the calendaring process, fabric S11 showed rigid structure that firmly bonded the fibres with melted sheath part (PE) of the bicomponent fibre due to which the fibres were unable to move freely in their surrounding area resulting in a reduction of the breaking extension in the MD, as shown in Figure 4.55. As a result of the calendaring process, the tensile strength of the fabric was reduced by 20% in the CD as compared with the non-calendared hydroentangled fabric S3 produced at 100 bars.

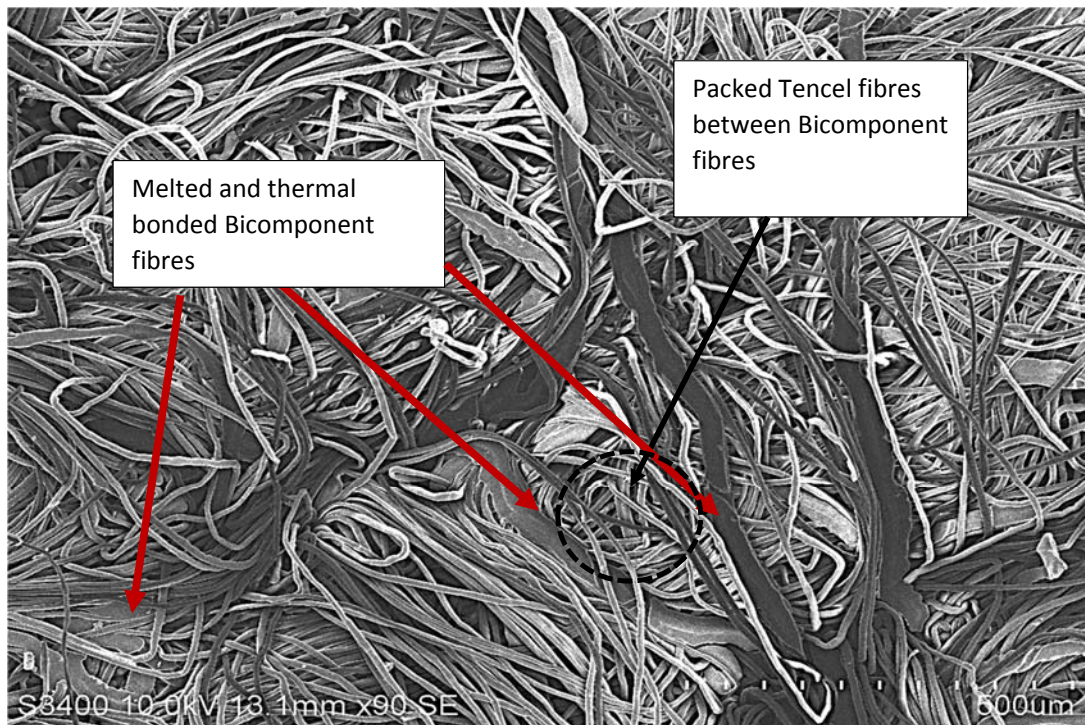


**Figure 4.55** Effect of calendaring process on the tensile properties of the hydroentangled nonwoven fabric S11 produced at 100 bars hydro pressure.



The results also showed nearly 14% lower tensile strength in the CD as compared with the thermally bonded fabric S7. The number of fibres in the CD was lower than those in the MD and also because of the high pressure of the calendaring rollers some of the fibres were damaged, which caused the reduction in tensile strength in the CD region.

The SEM image presented in Figure 4.55a shows that during the calendaring process the low melting (PE) sheath of the bicomponent fibre melted and penetrated into the body of the fabric and created the thermal bonding with their surrounding fibres. The red arrows indicate the molten fibres created bonding in the vicinity of the melt due to the roller pressure. This contributed to the increase in the tensile strength of the fabric observed in the machine direction. Figure 4.55a also demonstrates that the Tencel fibres were packed between the melted bicomponent fibres due to which the extensibility was reduced.



**Figure 4.55a** SEM of calendared hydroentangled nonwoven fabric S11 produced at 100 bars hydro pressure.

A comparison of Figures 4.55 with 4.53 show that the breaking extension of the calendared hydroentangled nonwoven S11 fabric exhibited lower value in the MD than

the hydroentangled nonwoven fabric S3 produced at 100 bars hydro pressure, prior to the calendaring process. The reduction in the breaking extension was due to the restriction of the fibre movement within the fabric. The fabric produced at 100 bars hydro pressure was compact and the fibres were very close to each other in the MD, therefore, the number of spaces between the fibres were reduced and after the calendaring process the fibres were packed between the melted fibres and created strong thermal bonding between them. Due to the strong inter-fibre bonding fabric S11 exhibited lower breaking extension in the MD as shown in Figure 4.55.

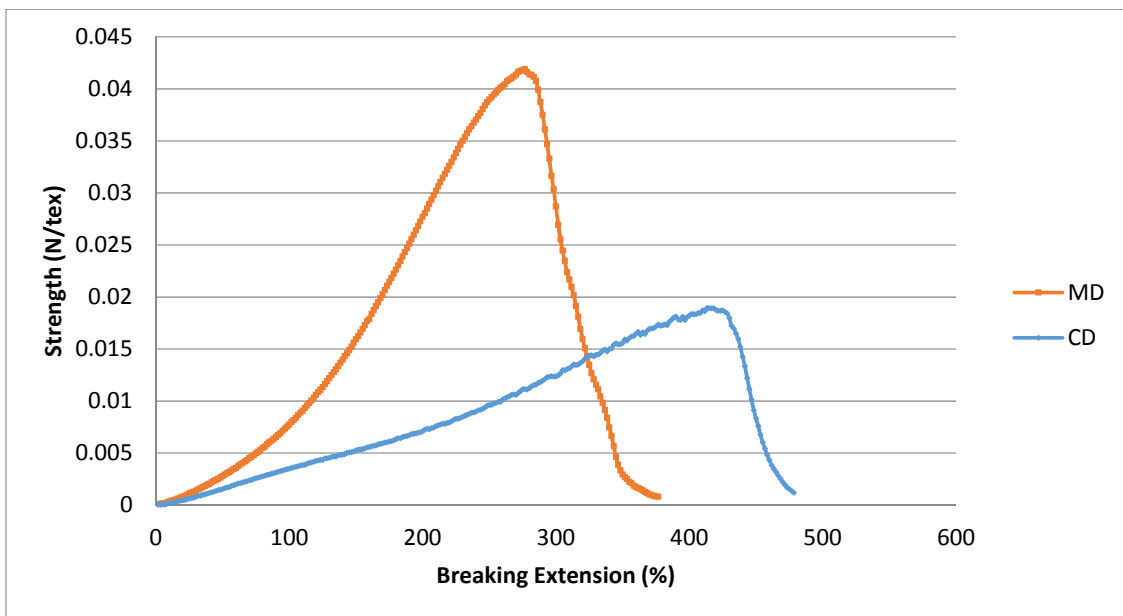
However, the calendaring process did not affect the breaking extension in the CD because the fibres are aligned mostly in the MD as strands in the structure of the fabric and fewer fibres are present in the cross machine direction. Therefore the chances of the presence of the bicomponent fibres in the cross direction are less and as result the extent of thermal bonding due to the calendaring process will be not as significant. Therefore, after calendaring process the breaking extension and the tensile strength of the fabric S11 will not be much affected in the CD. These results clearly show that the tensile properties of the hydroentangled nonwoven fabrics can be improved by the judicious use of the finishing processes, such as thermal bonding and calendaring.



**Figure 4.55b** SEM of calendared hydroentangled nonwoven fabric S11 showing structure of the fabric.

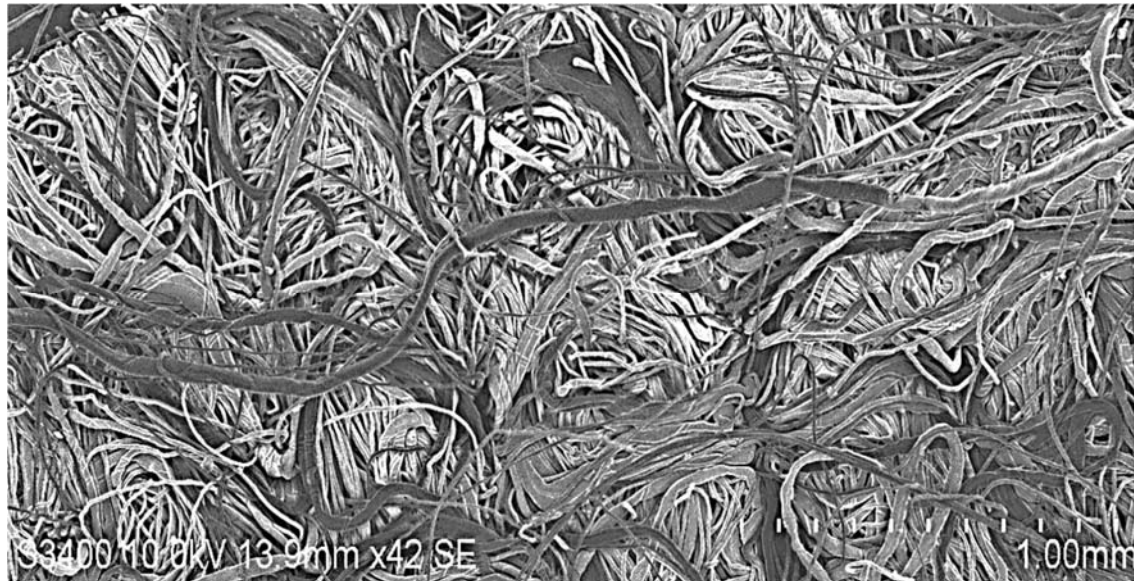
#### 4.2.9.6. Tensile properties of hydroentangled fabric produced at 125 bars pressure (S4)

The results presented in Figure 4.56 are for the tensile properties of the hydroentangled nonwoven fabric S4 produced at 125 bars hydro pressure. These results show that the tensile strength (0.041 N/tex) and breaking extension (408 %) of this S4 fabric in the machine direction was very similar to those obtained for the fabric produced at 100 bars hydro pressure. At this pressure, the fibres were rearranged very close to each other as shown in Figure 4.56a and it can be seen that most of the fibres are present in the MD as strands.



**Figure 4.56** Effect of 125 bars hydro pressure on the tensile properties of the hydroentangled nonwoven fabric S4

The tensile strength of the fabric S4 in the CD was increased by 20% as compared to the hydroentangled nonwoven fabric S3 produced at 100 bars hydro pressure. At 125 bar hydro pressure, the fibres were more aligned in the fabric structure that facilitated the increase of tensile strength of the fabric in the CD. The breaking extension of the fabric S4 was also increased by 13% in the CD, as shown in Figure 4.56. Figure 4.56a demonstrates the compact structure of the fabric S4, which facilitates the formation of an even surface due to the presence of closely packed large number of fibres per unit area of the fabric. Further tests show this fabric has favourable characteristics for clothing applications, as will be discussed in the later chapters.

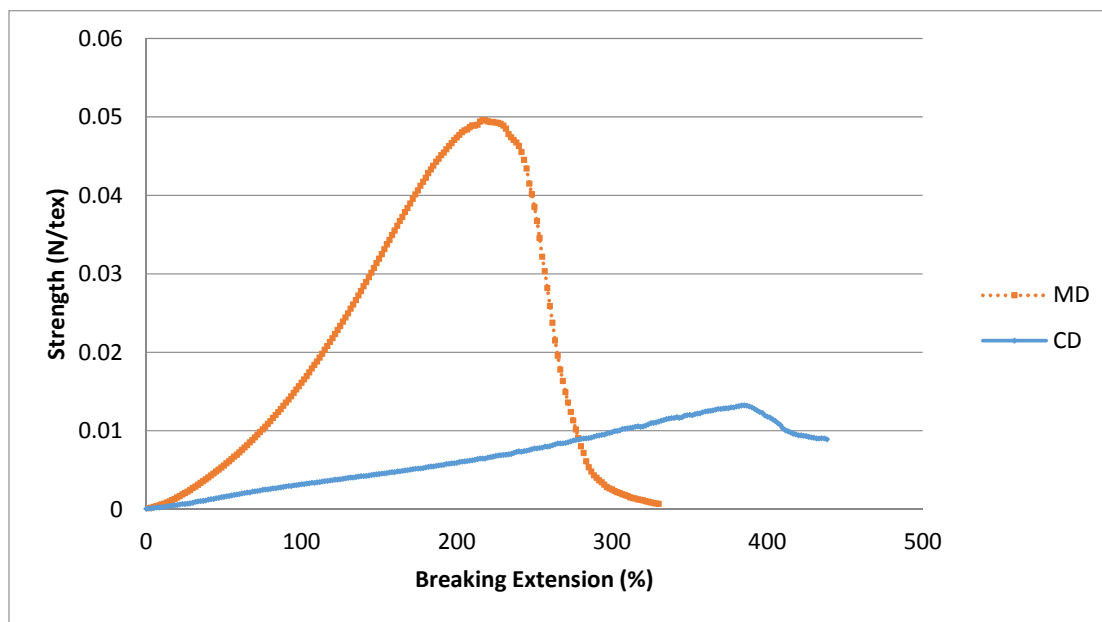


**Figure 4.56a** SEM of hydroentangled nonwoven fabric produced at 125 bars hydro pressure S4.

#### ***4.2.9.6.1 Effect of thermal bonding on the tensile properties of the hydroentangled nonwoven fabric S8 produced at 125 bars***

Thermally bonded hydroentangled nonwoven fabric S8 produced at 125 bars hydro pressure exhibited approximately 19% higher tensile strength in MD than the hydroentangled nonwoven fabric without the application of thermal finishing process. As discussed earlier, the high intensity of the hydro pressure at 125 bars, the fibres were more closely packed. Therefore, after the application of the heat strong bonds were created between the low the melting bicomponent fibres with the neighbouring fibres, which increased the tensile strength of the fabric (Figure 4.57).

A comparison of the thermally bonded hydroentangled nonwoven fabric S8 produced at 125 bar with the thermally bonded nonwoven fabric S7 produced at 100 bars hydro pressure show that this fabric exhibited 14% higher tensile strength in the MD, which is a result of the somewhat more compact fabric structure obtained at the higher hydro pressure. There were more thermally bonded fibres per unit area of the fabric thus imparting greater strength to the fabric after the thermal finishing process. The breaking extension of the fabric in the MD was reduced by 20% due to the greater restriction of the movement of the fibres within the fabric structure, as explained in the previous section. This fabric exhibited 27% lower tensile strength in CD as compared to the hydroentangled fabric without thermal processing.

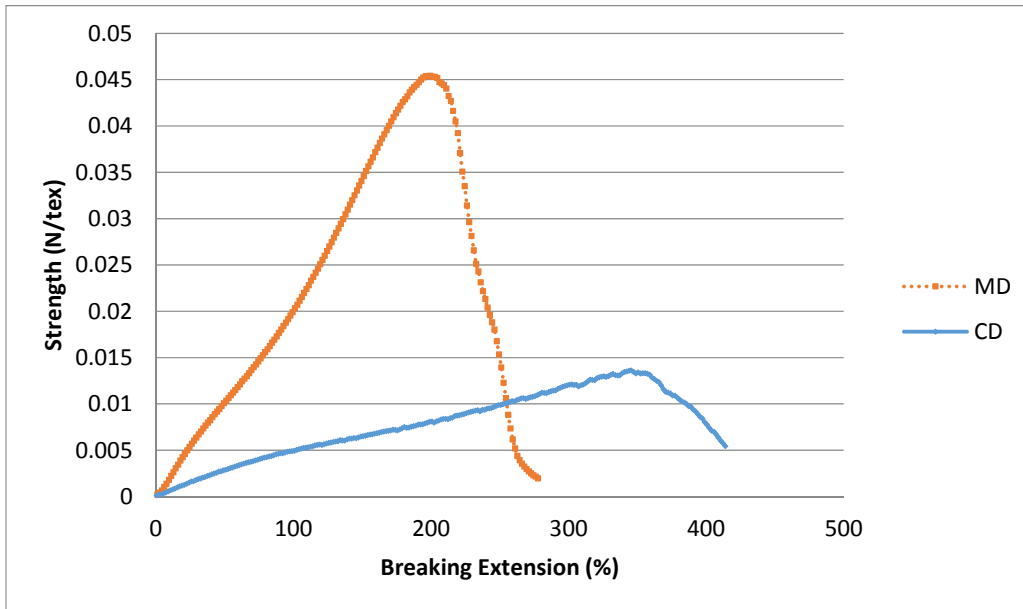


**Figure 4.57** Effect of thermal process on the tensile properties of the hydroentangled nonwoven fabric S8 produced at 125 bars hydro pressure.

**4.2.9.6.2 Effect of calendaring process on the tensile properties of the hydroentangled nonwoven fabric S12 produced at 125 bars**

The results for the tensile properties of the calendared hydroentangled nonwoven fabric S12 produced at 125 bars hydro pressure are presented in Figure 4.58. It can be seen that there was an increase (10%) in the tensile strength of the fabric in MD after the calendaring process and this value (0.045 N/tex) was somewhat lower than that obtained for the same fabric S8 after the thermal finishing process. It was expected that the tensile strength of the calendared fabric would be higher than the thermally processed fabric as observed for the previous fabric samples. However, a lower tensile strength value was obtained for the calendared fabric S12 as compared to the thermally bonded fabric S8. There are different possible reasons of reduction in the tensile strength after the calendared process; firstly, the damage caused to the fibres by the calendaring process, and secondly the lower number of bicomponent fibres present per unit area of the fabric and during calendared process they did not play any significant role in enhancing the tensile strength in the MD. After the calendaring process, the breaking extension of the fabric was reduced by 28% as compared to the hydroentangled nonwoven fabric without the calendaring treatment. The breaking extension was also 10% lower than the thermally bonded

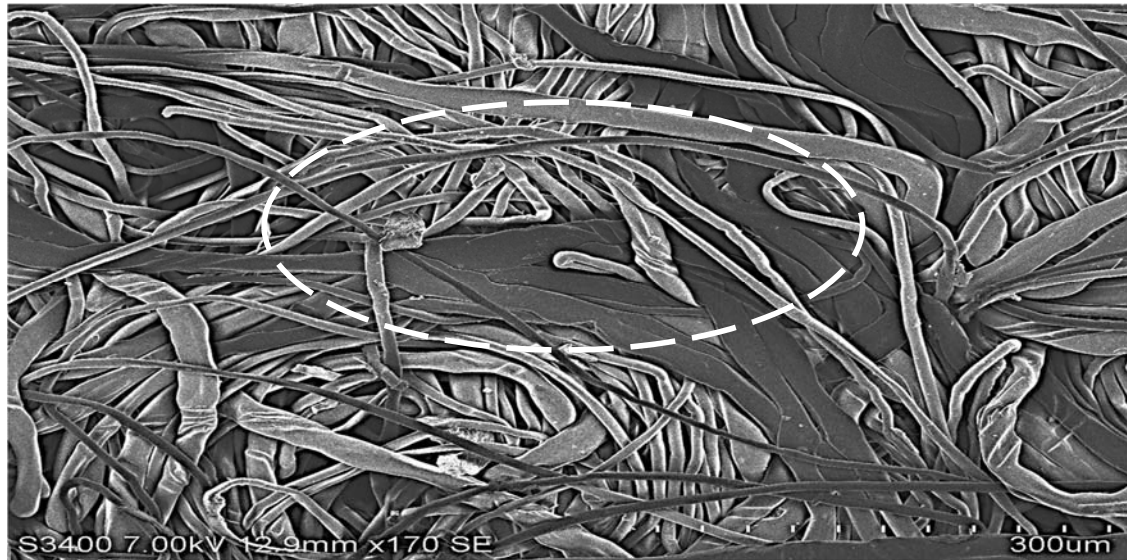
hydroentangled fabric S8. Figure 4.57 shows that after the calendaring process the fibres were more rigidly placed in the fabric structure, hence causing restriction in the free movement of the fibres within the fabric.



**Figure 4.58** Effect of calendaring process on the tensile properties of the hydroentangled nonwoven fabric S12 produced at 125 bars hydro pressure.

The tensile strength of the calendared fabric S12 in the CD was decreased by 28% as compared to the hydroentangled nonwoven fabric S4 and there were no noticeable changes in tensile strength values as compared to the thermal bonded nonwoven fabric S8. The breaking extension in the CD also decreased by 16% as compared to the hydroentangled nonwoven fabric S4 and by 8% compared to the thermally bonded nonwoven fabric S8. Figure 4.58a shows that the melted fibres restricted the movement of the fibres in the fabric structure and caused the reduction in breaking extension of the fabric.





**Figure 4.58a** SEM of calendared hydroentangled nonwoven fabric S12 produced at 125 bars hydro pressure

It can be seen from the Figures 4.58 and 4.55 that the CD breaking extension of the calendared-hydroentangled nonwoven fabric S12 produced at 125 bars hydro pressure was almost the same as that of the calendared hydroentangled nonwoven fabric S11 produced at 100 bars hydro pressure.

#### **4.2.10. Tensile properties of hydroentangled nonwoven fabrics with pre-needle punching**

The nonwoven fabrics prepared by using the hydroentanglement process (with pre-needling process) showed higher tensile strength values than those prepared by using the hybrid (needlepunching-hydroentanglement) process. The tensile properties of the nonwoven fabrics produced via the hydroentangled process with pre-needling are discussed in the following sections.

##### **4.2.10.1. Hydroentangled fabric S13 produced at 100 bars hydro pressure**

Hydroentangled nonwoven fabric S13 produced at 100 bars hydro pressure exhibited strength in MD that was 58% higher than the hydroentangled nonwoven fabric S3 produced by using the hydroentanglement and needle-punched process at 100 bars hydro pressure. It was because of intensive mechanical entangling of the fibres. Because of pre-needling, the fibres in the web were able to freely move within the web structure. On the other hand, the fibres in the intensive needle punched already

consolidate and were not able to freely move in the web structure. Therefore, during hydroentanglement process, the fibres were not highly entangled due to which, pre-needled web showed maximum tensile strength than the needled punched and hydroentanglement (Hybrid) samples.

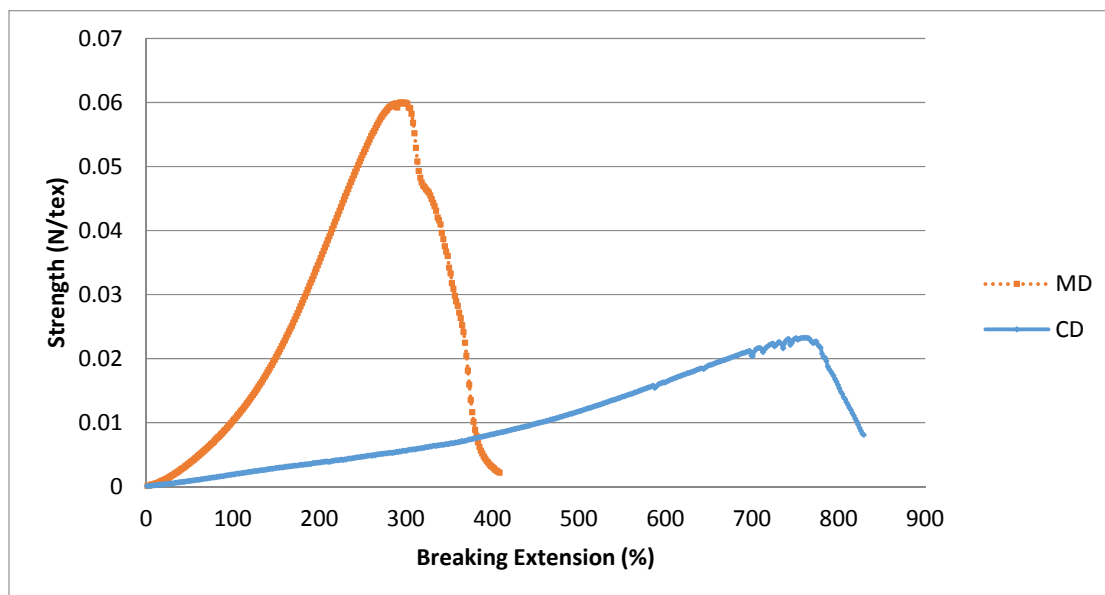
The thickness of the needlepunched-hydroentangled nonwoven fabric S3 was 0.48mm and that of the thickness of this hydroentangled fabric S13 was 1.00 mm.

Needlepunched-hydroentangled nonwoven fabric showed higher number of fibres in per unit area because during needling process the fibres were tightly consolidated, because of the action of the needle plate, which hit the web and moved the fibres in the web structure that led to higher mechanical bonding between the fibres. This has a direct effect on the tensile properties of the hydroentangled nonwoven fabrics.

It did not impact on the extensibility behaviour of the fabric such as the breaking extension of this fabric almost remain the same or little lower by 3.5% as compared with the needle-punched hydroentangled fabric produced at the same pressure as shown in Figure 4.59. It was because of intensive entangling between the fibres that restricted the fibres movement and led to almost no change in breaking extension.

The tensile strength of the hydroentangled fabric S13 in the CD was 0.023 N/tex, which was 53% higher than the nonwoven fabric S3 produced by using the hybrid process at the same pressure and a significant increase in the breaking extension (105%) of the fabric was also observed. This increase in breaking extension was because of higher strength in cross direction because of firm entangling of the fibres. The microscopic image presented in Figure 4.59a demonstrates that the fibres are predominantly aligned in the MD and were entangled very intimately leading to the enhancement of the tensile strength of the hydroentangled fabric.

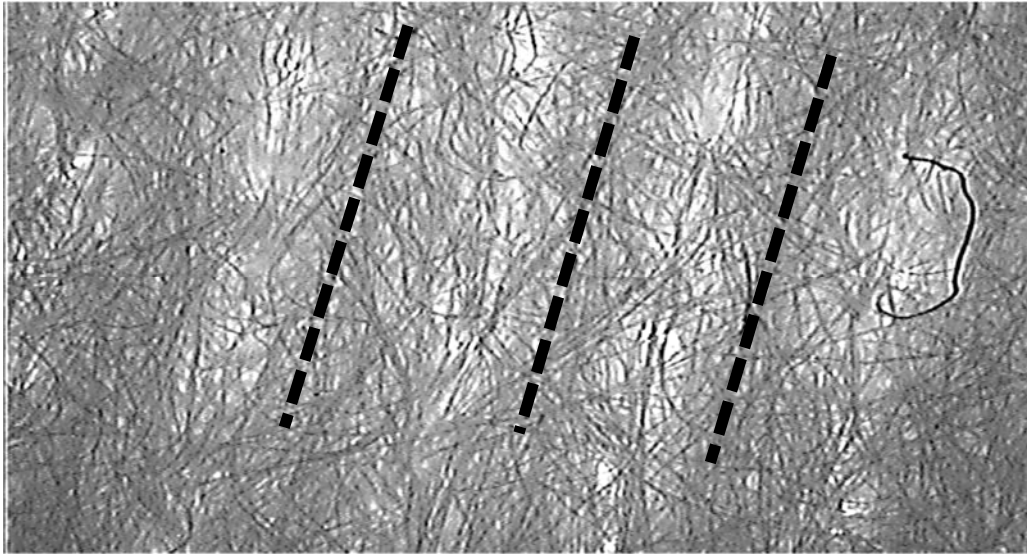




**Figure 4.59** Tensile properties of hydroentangled nonwoven fabric S13 produced at 100 bars hydro pressure with pre-needling process

Needlepunched-hydroentangled nonwoven fabrics showed lesser number of fibres per unit area because during the needling process the fibres were dispersed due to the action of the needle plate, which hit the web and moved the fibres into different directions thus resulting in the lower amount of fibres per unit area of the fabric. This has a direct effect on the tensile strength of the hydroentangled nonwoven fabrics. However, it did not affect the extensibility behaviour of the fabric, as the breaking extension of this fabric remained almost the same or little lower by 3.5% as compared to the needlepunched-hydroentangled fabric produced at the same pressure, as shown in Figure 4.59.

The tensile strength of the hydroentangled fabric S13 in the CD was 0.023 N/tex, which was 53% higher than the nonwoven fabric S3 produced by using the hybrid process at the same pressure and a significant increase in the breaking extension (105%) of the fabric was also observed. This increase in breaking strength in the CD was because of the presence of more fibres per unit area of the fabric in this direction and the microscopic image presented in Figure 4.59a shows that the fibres are predominantly aligned in the MD and were entangled very intimately leading to the enhancement of the tensile strength of the hydroentangled fabric.



0.58 mm

**Figure 4.59a** Microscopic view of hydroentangled nonwoven fabric S13 (pre-needling) produced at 100 bars hydro pressure.

**4.2.10.1.1. Effect of thermal bonding on the tensile properties of the hydroentangled nonwoven fabric S15 produced at 100 bars hydro pressure (Pre-needling)**

Figure 4.60 shows the effect of thermal processing on the tensile properties of the hydroentangled fabric S15 prepared at 100 bar pressure. The results show that the tensile strength in the MD was enhanced by 9% (from 0.058 N/tex to 0.063 N/tex) when hydroentangled fabric was subjected to the thermal treatment. During thermal processing of the fabric the low melting sheath part (PE) of the Bicomponent fibres melted and created strong bonds with the surrounding fibres and enhanced the tensile strength in the MD of the fabric.

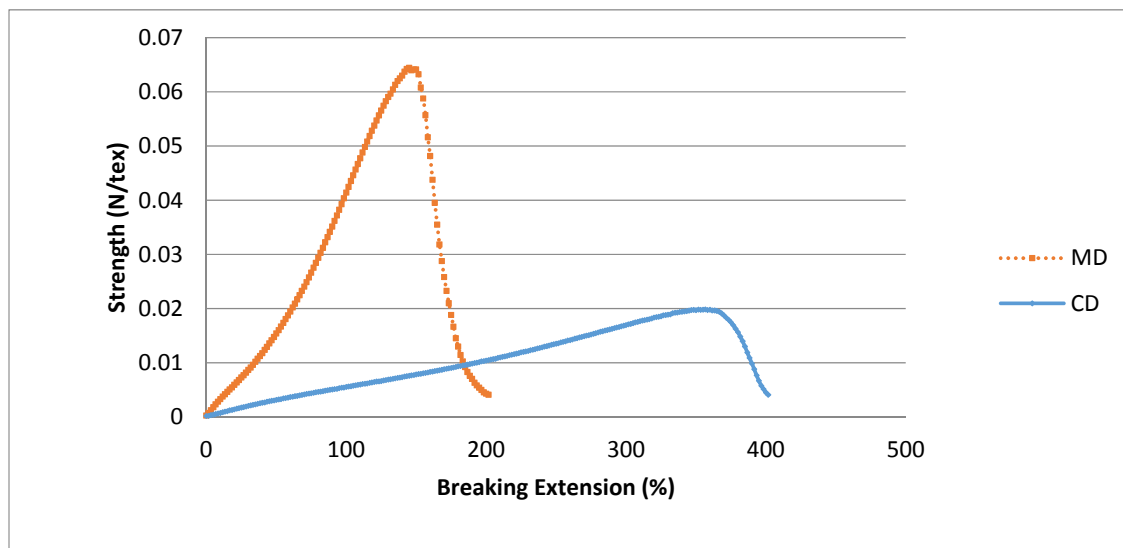
It was because of less number of bi-component fibres in the cross-section of the sample. Such as, table 4.5 demonstrated that samples prepared through pre-needled and hydroentanglement process exhibited lower bulk density than the samples produced through needle punched and hydroentanglement process. The samples produced through pre-needling and hydroentanglement process showed  $0.151 \text{ g/cm}^3$  bulk density, and the sample produced through needle punched and hydroentanglement process showed  $0.277 \text{ g/cm}^3$  bulk density, even both samples produced at the same hydro pressure that was 100 bars.

Its mean, after thermal process, samples produced through needle punched process will exhibit higher tensile strength because of higher number of bi-component fibres in cross-section of the fabric than the sample produced through pre-needled and hydroentanglement process.

These were the reasons due to which this thermal processed fabric could not exhibited a noticeable change in tensile strength.

The breaking extension decreased by 51% in MD (from 273% to 133%), it was because of the inter-fibre bonding, due to the melting of the PE sheath, which held the fibres together and restricted their movement within the fabric upon the application of an external force.

However, the tensile strength in the CD decreased by 9% (from 0.023 N/tex to 0.021N/tex), which shows that the thermal bonding did not any significant influence on the tensile strength probably due to the presence of fewer bi-component fibres in the cross direction. As, it has been discussed earlier that because of spaces between the fibres, during heating process some fibres were shrunk and caused reduction in tensile strength in CD during thermal process.



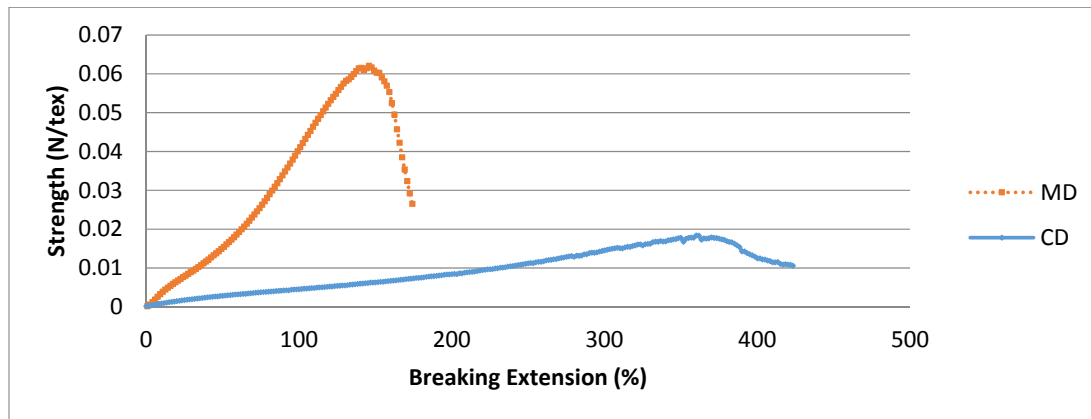
**Figure 4.60** Effect of thermal bonding on tensile properties of the hydroentangled nonwoven fabric S15 (Pre-needling) produced at 100 bars hydro pressure

#### 4.2.10.1.2. Effect of calendaring process on the tensile properties of hydroentangled nonwoven fabric S17 (pre-needling) produced at 100 bars hydro pressure

The tensile properties of the calendared hydroentangled nonwoven fabric S17 produced at 100 bar hydro pressure were studied. The results presented in Figure 4.61 show a small increase (5%) in the tensile strength in the MD as compared to the corresponding untreated nonwoven fabric. However, this value was about 3% lower than the thermally bonded fabric S15. It has been noted here that calendaring process did not enhance the tensile properties of the hydroentangled fabric. As, it has been explained earlier that because of less amount of bi-component fibres in the cross-section of the fabric.

The tensile strength in the CD of the calendared hydroentangled nonwoven fabric S17 was reduced by 21.7%, when compared with the non-calendared fabric S13 and by 14% compared to the thermally bonded fabric S15. It was because of damaging of fibres during calendaring process.

The breaking extension in MD of the calendared fabric S17 was also reduced by 50.5% as compared to the untreated fabric S13 and by 2.5% compared to the thermally bonded fabric S15. It is understood that the fibres in the hydroentangled fabric were free to move in the fabric region due to the inter-fibre mechanical and thermal bonding between the fibres. The resulting fabric S17 exhibited a rigid structure and lower breaking extension, as shown in Figure 4.61.



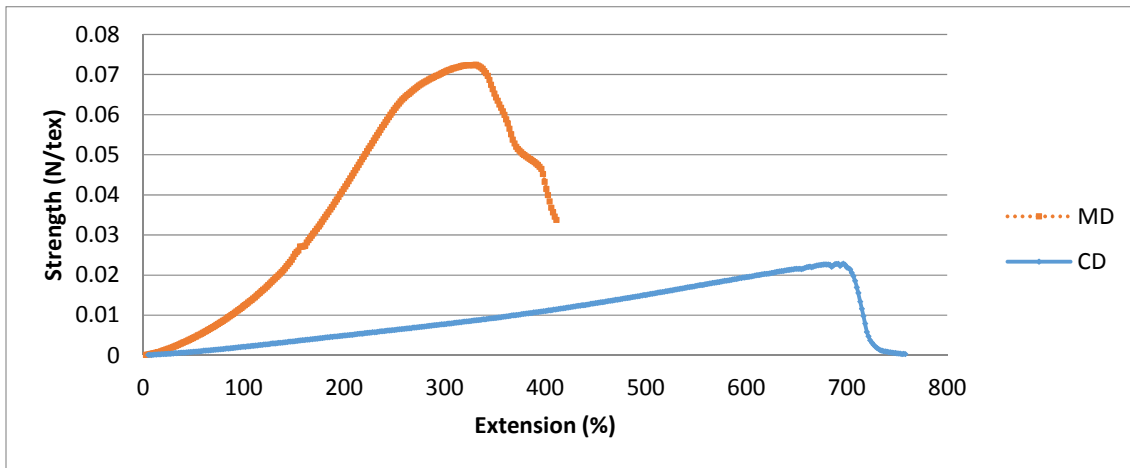
**Figure 4.61** Effect of calendaring process on tensile properties of the hydroentangled nonwoven fabric S17 (pre-needling) produced at 100 bars hydro pressure

#### ***4.2.10.2. Hydroentangled fabric S14 (pre-needling) produced at 125 bars hydro pressure***

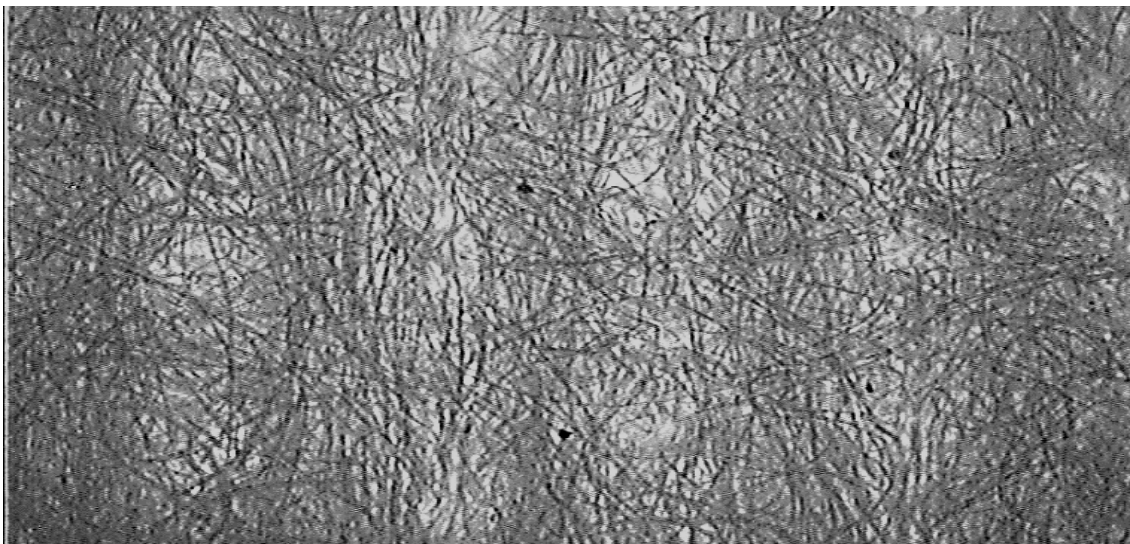
The results presented in Figure 4.62 show that the tensile strength of the hydroentangled nonwoven fabric S14 prepared at 125 bars hydro pressure was 0.074 N/tex in the MD, which was almost 27% higher than the hydroentangled nonwoven fabric S13 produced at 100 bars hydro pressure. It was because of the high pressure that the fibres were highly entangled and twisted with their surrounding fibres. The high pressure also reduced the thickness of the fabric, which was 88mm and 14% lower than the fabric produced at 100 bars pressure. At this pressure the tensile strength of the fabric was increased because of the reverse action of the water. Due to high hydro pressure more fibres were tightly twisted, which resulted in stronger mechanical bonding between and hence the higher tensile properties of the fabric produced at 125 bar hydro pressure.

The breaking extension of the fabric S14 produced at 125 bar hydro pressure was 24% lower than the hydroentangled fabric S13 produced at 100 bars hydro pressure. It was because of the higher mechanical bonding between the fibres, which restricted the movement of the fibres within the structure of the fabric as compared to the fabric produced at 100 bars and secondly because of the high compaction of the fabric structure, which further restricted fibre movement in the fabric region.

Figure 4.62a is a microscopic image of the hydroentangled fabric S14 produced at 125 bar hydro pressure. It can be seen that the number of strands per unit area of the fabric were greater than those observed in the image of the corresponding fabric S13 produced at 100 bars hydro pressure (Figure 4.59a). There was no significant changes in the tensile strength of the fabric in the CD as compared to the fabric produced at 100 bars hydro pressure. However, the breaking extension of this fabric was increased by 15% in the MD.



**Figure 4.62** Tensile properties of the hydroentangled nonwoven fabric S14 (pre-needling) produced at 125 bars hydro pressure



0.58 mm

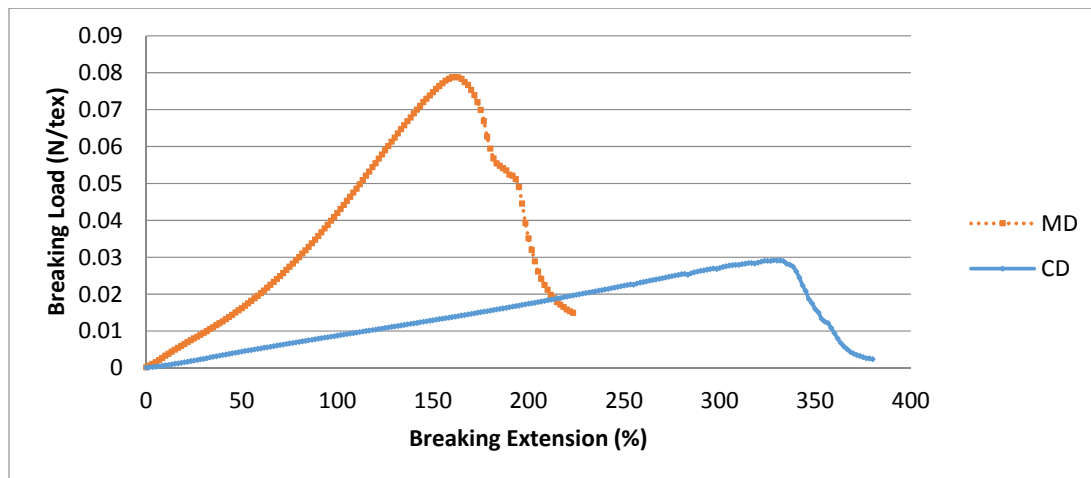
**Figure 4.62a** Microscopic view of hydroentangled nonwoven fabric S14 produced at 125 bars hydro pressure.

A comparison of Figures 4.62a and 4.59a shows that the fabric S14 produced at 125 bar hydro pressure exhibited a structure where the fibres are more uniformly dispersed than the fabric S13 produced at 100 bar pressure. This leads to the greater fibre entanglement and stronger mechanical bonding between the fibres, hence the fabric produced at the higher hydro pressure exhibits higher tensile strength and somewhat lower breaking extension, as shown in Figure 4.62.

#### 4.2.10.2.1 Effect of thermal bonding on the tensile properties of hydroentangled nonwoven fabric S16 (pre-needling) produced at 125 bars hydro pressure

The hydroentangled fabric S16 produced at 125 bar pressure was subjected to the thermal treatment processes. The tensile properties of the heat treated fabric were determined and compared with the corresponding untreated fabric. The results illustrated in Figure 4.63 show that the tensile strength of the fabric S16 increased from 0.074 N/tex to 0.078 N/tex (7%) in the MD. This increase in the tensile strength can be explained as previously, on the basis of the formation of a more compact fabric structure and the enhanced thermal bonding due to the melting of the sheath of the bicomponent fibres.

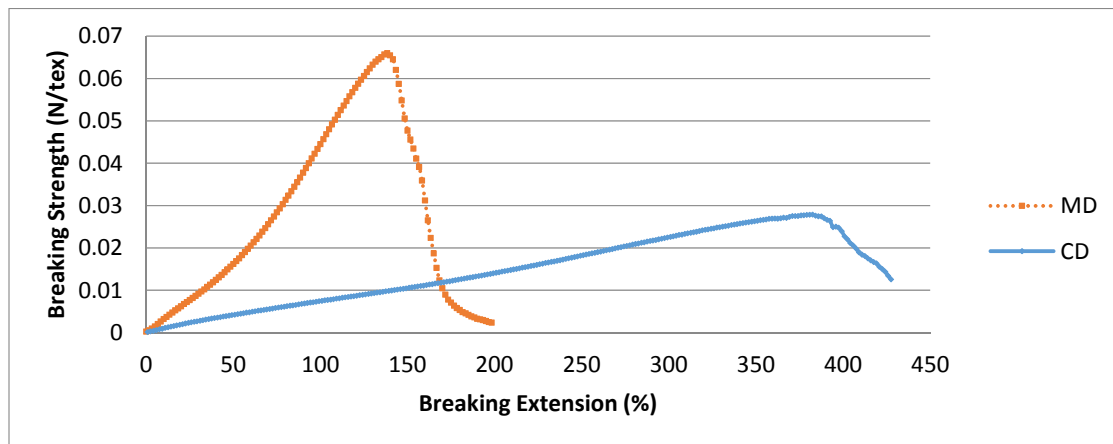
The breaking extension of the fabric S16 in the MD was reduced from 206% to 156% due to the stronger inter-fibre bonding, which restricted fibre movement upon the application of a tensile force. The fibres were aligned and compacted as shown in Figure 4.62a due to which the spaces between the fibres were reduced and then after the thermal bonding process the fibres were not able to move freely within the fabric structure in the MD, which led to a reduction in the extensibility of the thermally bonded fabric in the MD, as shown in Figure 4.63. The tensile strength of the fabric in the CD was also increased from 0.023 N/tex to 0.030 N/tex (30%) and this was accompanied by a decrease in the CD breaking extension (53%) of the thermally treated fabric as compared to the untreated fabric S14.



**Figure 4.63** Effect of thermal bonding on tensile properties of the hydroentangled nonwoven fabric S16 (pre-needling) produced at 125 bars hydro pressure

#### 4.2.10.2.2 Effect of calendaring process on the tensile properties of hydroentangled nonwoven fabric S18 (pre-needling) produced at 125 bars hydro pressure

The results presented in Figure 4.64 show that after the calendaring process, the tensile strength of the fabric S18 was decreased by 18% as compared to the tensile strength of the thermally bonded hydroentangled nonwoven fabric S16, and the value was 13% lower than the untreated fabric produced at 125 bar hydro pressure. The decrease in the tensile strength of the fabric S18 was likely to be due to the diffusion of the melted bicomponent fibres, which may also have been damaged by the application of the high roller pressure at the elevated temperature. Analysis of the SEM image presented in Figure 4.64a show that the bicomponent of fibres are melted and flattened instead of just softening, whereas these fibres are only soften and create bonding with neighbouring fibres in the thermal bonding process. This may be another reason why the calendared fabric shows the lower tensile strength than the thermally bonded fabric



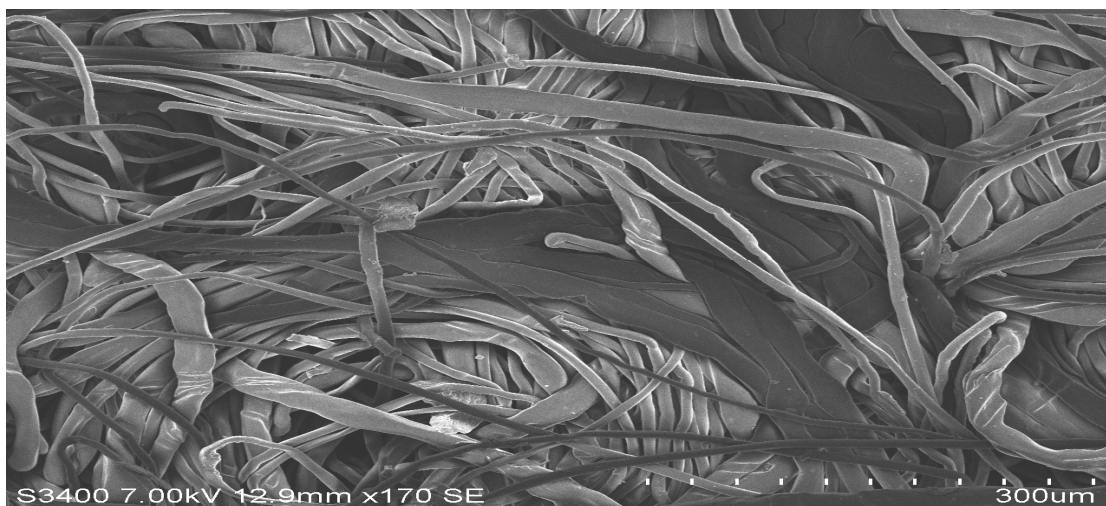
**Figure 4.64** Effect of calendaring process on tensile properties of the hydroentangled nonwoven fabric S18 (pre-needling) produced at 125 bars hydro pressure

The breaking extension of the calendared fabric S18 in the MD was reduced by 58% as compared to the untreated fabric. The reasons for the reduction in the breaking extension in the MD of the calendared fabric S18 can be summarised as given below:

1. The action of the pressure rollers causes the fibres to stretch and disperse within the fabric, which reduces the number of fibres per unit area of the fabric.
2. Fibre damaged.



On the other hand, the tensile strength in the CD was decreased by 6.6% compared to the corresponding thermally processed hydroentangled nonwoven fabric S16 and increased by 21.7% compared to the untreated nonwoven fabric S14. The breaking extension in the CD was increased by 14% compared to the thermally finished (S16) and hydroentangled fabrics (S14). The breaking extension was lower by 46% when compared with the untreated hydroentangled nonwoven fabric.



**Figure 4.64a** SEM of calendared hydroentangled nonwoven fabric S18 produced at 125 bars hydro pressure

#### **4.2.11. Tensile properties of commercial nonwoven fabric (E1 and W1)**

The fabric area density of the commercial nonwoven fabric E1, used for comparison, was very similar to that of the hydroentangled nonwoven fabrics produced in this study. However, the commercial fabric E1 comprised of polyamide (PA) and polyester (PET) island in the sea bi-component filament fibres and the detailed technical data related to the fabric is presented in chapter 3. The tensile properties of the commercial nonwoven E1 were determined and the results are presented in Figure 4.65.

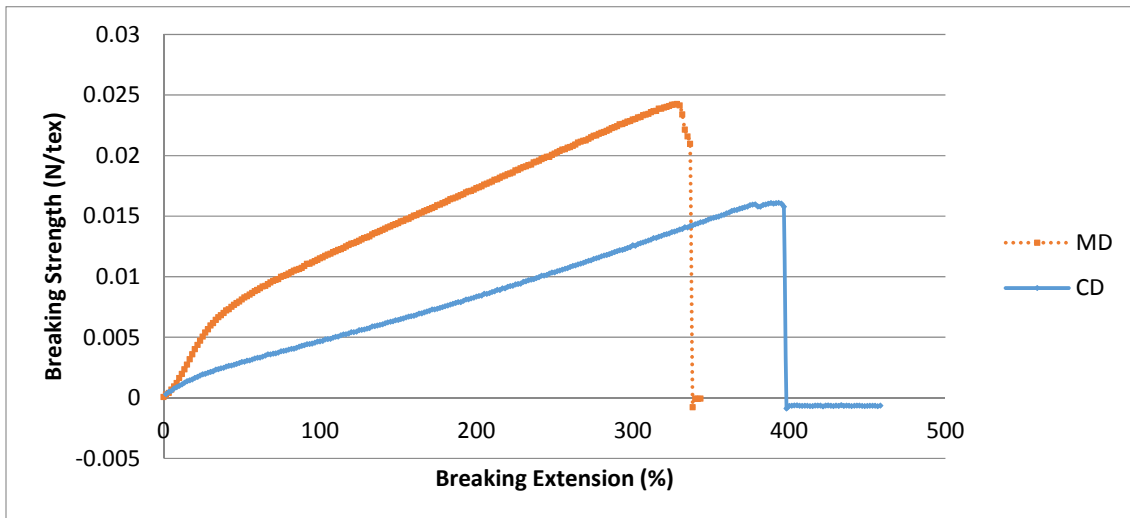
It can be seen that the tensile strength of the commercial hydroentangled nonwoven fabric E1 was 0.024 N/tex in MD and 0.016 N/tex in the CD. The breaking extension of E1 fabric was 328% and 379% in the MD and CD, respectively. When these results were compared with the hydroentangled nonwoven fabric produced at 100 (S13) and 125 bars (S14) hydro pressure with pre-needling process, then it can be seen that the MD tensile strength of the commercial nonwoven fabric was 59% lower than the fabric

S13 developed at 100 bars pressure (pre-needling) and 51% lower than the fabric S14 produced at 125 bars hydroentanglement pressure (pre-needling).

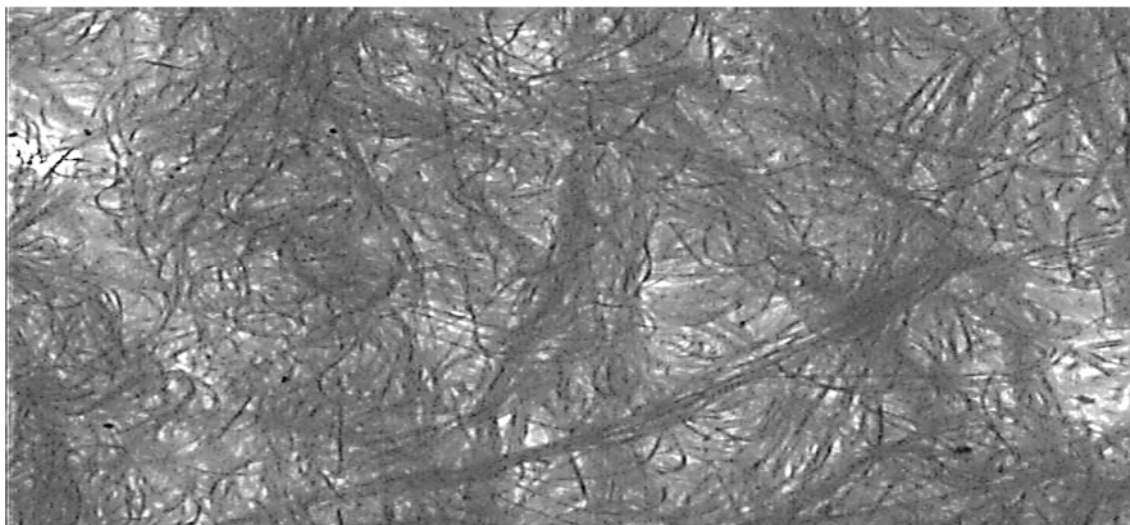
The results for the commercial nonwoven hydroentangled fabric E1 were compared with the results of the best developed thermal bonded hydroentangled fabric S16 produced at 125 bars hydro pressure. It was found that the commercial nonwoven fabric E1 exhibited nearly 70% lower tensile strength in MD and 47% lower in CD, as given in Figure 4.65 and Figure 4.63. This was mainly due to the better alignment of the fibres in the MD and also because of the firmly entangled fibres that enhance the mechanical bonding between the fibres. But after the thermal processing of the fabric, the tensile strength of developed hydroentangled fabric S14 was increased.

The fibres in the commercial nonwoven fabric E1 are dispersed in somewhat random manner (Figure 4.65a). The fibres were not aligned in one direction and this resulted in the significantly lower tensile strength in the MD for the commercial nonwoven E1 fabric as compared to the nonwoven fabric S14 produced at 125 bar hydro pressure in this study (Figure 4.65).

The breaking extension of the commercial hydroentangled nonwoven fabric E1 was 328% in the MD and 379% in the CD. The breaking extension of this fabric E1 was 20% higher than the fabric S13 produced at 100 bars pressure and 59.2% higher than the fabric S14 produced at 125 bars pressure in MD. This higher extension was because of the scattered filaments within the structure of the fabric and it can be seen in Figure 4.65a that there were enough spaces between the fibres for freely movement to take place within the fabric structure. Secondly, the commercial nonwoven fabric E1 was produced by using continuous filaments and during the tensile testing it gave higher breaking extension as compared to the fabric produced by using staple fibres.



**Figure 4.65** Tensile properties of commercial hydroentangled nonwoven fabric (E1)



0.58 mm

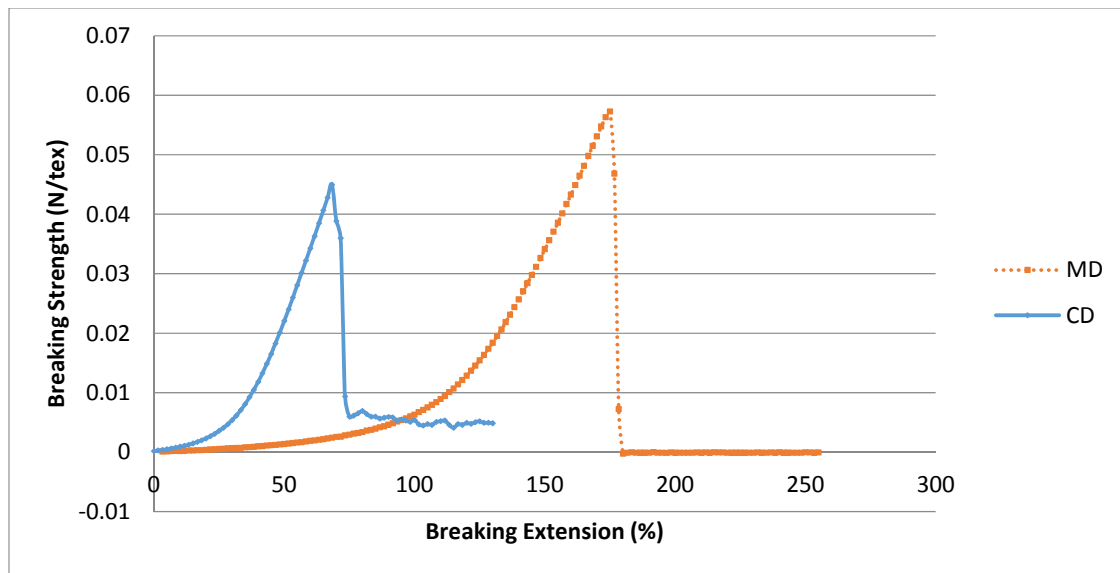
**Figure 4.65a** Microscopic view of commercial nonwoven fabric (E1)

Commercial hydroentangled nonwoven fabric exhibited 379% breaking extension in the CD that was 49% lower than the fabric produced at 100 bars hydro pressure and 45% lower than the fabric produced at 125 bars hydro pressure. It was because of multi-dimensional arrangement of the filaments in the fabric structure as seen in figure 4.65a. Commercial nonwoven fabric was analysed and it was found that there were no great differences between the breaking extension in the MD and the CD of the

fabric. The reason for this is the isotropic structure of the commercial fabric as illustrated in Figure 4.65a, which also shows that the filaments were not aligned in any one direction in the fabric structure.

#### 4.2.12. Tensile properties of woven fabric (W1)

The results presented in Figure 4.66 show that the woven fabric W1 exhibited higher MD tensile strength than the commercial nonwoven fabric E1, but lower than that obtained for the hydroentangled (with pre needling) nonwoven fabric S13 produced at 100 bars hydro pressure. The woven fabric exhibited 0.056 N/tex and 0.043 N/tex tensile strength in MD and CD, respectively (Figure 4.66). The hydroentangled nonwoven fabric S13 produced at 100 bars pressure exhibited 0.058 N/tex and 0.023 N/tex tensile strength in MD and CD, respectively (Figure 4.62), and the commercial nonwoven fabric E1 exhibited 0.024 N/tex and 0.016 N/tex in the MD and the CD, respectively (Figure 4.65). Therefore, a comparison of the results show that the woven fabric W1 exhibited higher tensile strength in MD and CD compared to the commercially available nonwoven fabric E1, but exhibited lower tensile strength in MD compared to the hydroentangled nonwoven (pre-needling) fabric S13 produced at 100 bars hydro pressure.

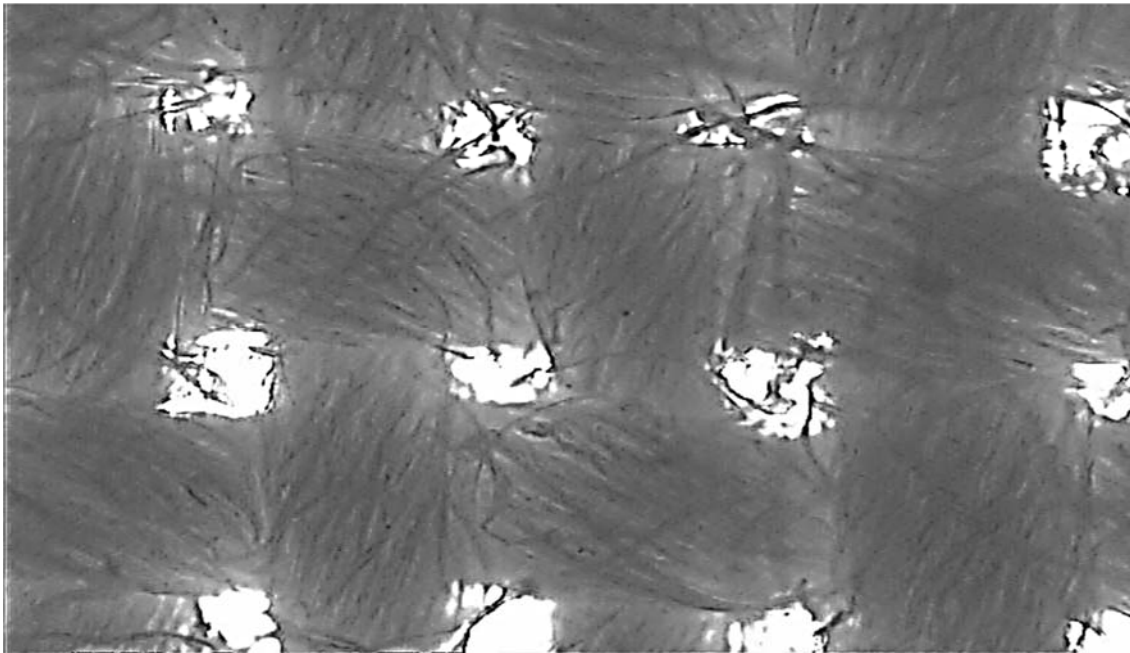


**Figure 4.66** Tensile properties of woven W1 fabric in machine and cross directions

The higher strength in MD was because of the alignment of the yarns in the warp direction, also the fibres in the yarn were twisted and every fibres contributed to tensile

strength of the woven fabric the in the MD. Secondly, the fabric structure (plain weave) also facilitates the fabric in tensile strength such as in plain weave the weft yarns also contribute to the tensile strength of the fabric in the MD. The same phenomenon was repeated in the cross direction. There are many factors that affect the tensile strength of the woven fabric such as, yarn linear density, yarn twist per unit length, initial modulus of yarn, warp and weft density, yarn interlacement pattern and the crimps (160).

The breaking extension values of the woven W1 fabric were 173% in the MD and 66% in the CD. These breaking extensions values are significantly lower than the commercial hydroentangled E1 nonwoven and in the developed hydroentangled nonwoven fabrics S13 and S14 produced at 100 and 125 bars hydro pressure with pre-needling. It was lower by 47% in the MD as compared with commercial nonwoven E1 fabric and 37% lower in the MD than fabric S13 produced at 100 bars pressure. Woven W1 fabric also exhibited lower breaking extension in the CD as mentioned above; it was 82% lower than the commercial nonwoven E1 fabric and 91% lower than the nonwoven S13 fabric produced at 100 bar hydro pressure.



0.58 mm

**Figure 4.66a** Microscopic view of commercially available woven W1 fabric (plain weave)

The lower breaking extension was because there was no fibre movement in the fabric region. Figure 4.66a shows that the fibres are tightly twisted and because of these frictional forces the fibres were unable to move in the woven structure. Woven W1 fabric breaking extension mainly depends on the yarn movement in the fabric structure. As, it can be seen in Figure 4.66a, there are narrow spaces between the warp and the weft yarns and these spaces can allow some yarns to move within the woven fabric structure. Some other factors also play important roles in determining the tensile strength of the woven fabric. These factors include, the number of warps per inch and number of wefts per inch, fibre structure, weave pattern, etc.

#### 4.2.13. Comparisons of developed hydroentangled nonwoven fabrics with commercial hydroentangled nonwoven and woven fabrics

Four main developed fabrics samples were compared with the commercial hydroentangled nonwoven and woven fabrics. The details are given in Table 4.14.

**Table 4.14** Comparison of the characteristics of various fabrics tested

Fabric I.D.	Composition (%)	Area Density (g/m <sup>2</sup> )	Thickness (mm)	Fabric Type	Hydro-Pressure (bars)
S3	70 Tencel 30 Bicomponent	125	0.48	Needlepunched /Hydroentangled	100
S4	70 Tencel 30 Bicomponent	120	0.46	Needlepunched /Hydroentangled	125
S13	70 Tencel 30 Bicomponent	150	1.00	Pre-needled/Hydroentangled	100
S14	70 Tencel 30 Bicomponent	150	0.88	Pre-needled/Hydroentangled	125
E1	80 PET 20 PA	140	0.43	Spunlaying/ Hydroentangled	...
W1	100 Cotton	144	0.50	Woven	...

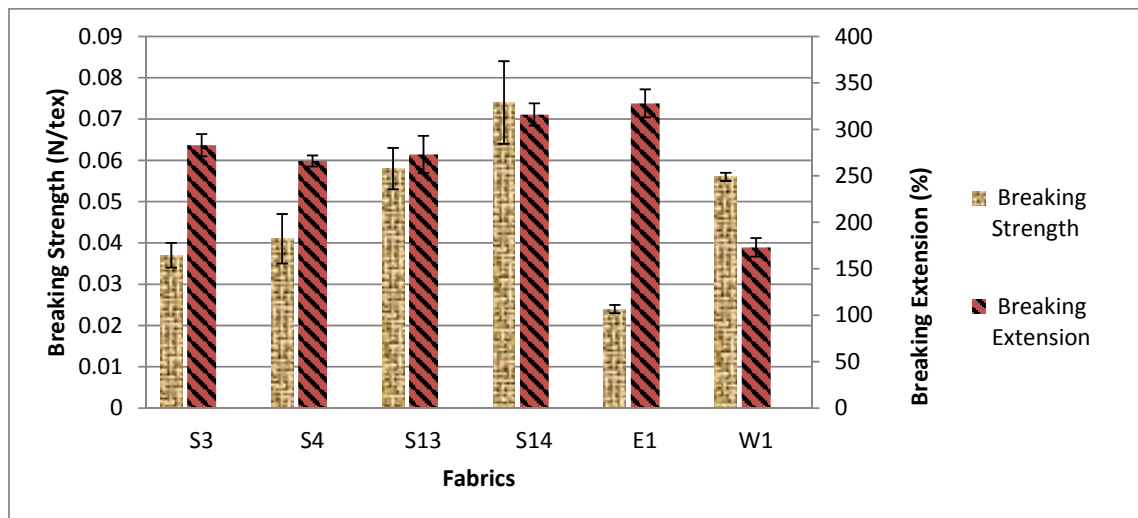
PA- polyamide, PET- polyester

The fabric thickness was measured according to BSI EN ISO 9073-2:1997 using the R&B Cloth Thickness Tester at a pressure of 1gmcm<sup>2</sup>. Five readings were taken for every sample of the fabric. The tensile properties of the developed hydroentangled nonwoven fabrics in MD were compared with the reference fabric E1 and W1. S3 and S4 fabrics were prepared through the hybrid system and it was observed that the fabric

produced through the hybrid system showed lower breaking strength and breaking extension as compared with the fabric S13 and S14 produced through the hydroentanglement process alone, as shown in Figure 4.67. This is mainly due to the fact that in the hybrid process the intense action of the needlepunching process causes dispersion of the fibres in the fabric structure and as a result the numbers of fibres per unit area of the fabric in the MD are reduced.

A comparison of samples S3 and S4 with the commercial nonwoven sample (E1) and the woven sample (W1) show that samples S3 and S4 had higher tensile strength compared to the E1 but lower extension to break value. E1 has higher numbers of fibres per unit area of the fabric, which enhances its extensibility but the fibre entanglement is less intensive hence the tensile strength in MD was lower than S3 and S4 (Figure 4.67). And commercial hydroentangled fabric also had the PA fibres in its structure that also assist in extensibility of the fabric.

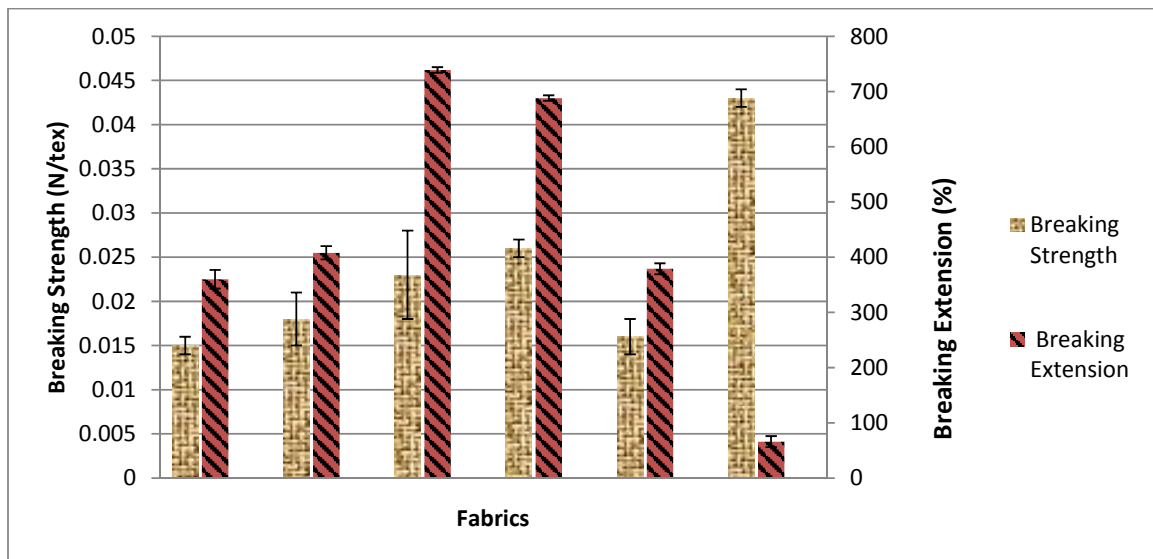
On the other hand, if S3 and S4 compared with the W1 (woven) fabric samples then it was observed that the tensile strength of W1 was greater than S3 and S4 because of the woven structure that comprised of warp and weft yarns. Also because of the woven structure the extensibility in MD of the fabric was lower than the hydroentangled fabrics of S3 and S4.



**Figure 4.67** Comparisons of tensile strength in MD of different hydroentangled nonwoven fabrics produced at different hydro pressures with commercial hydroentangled and woven fabrics

From the Figure 4.67, it can be seen that S13 and S14 showed the highest tensile strength in MD as compared to reference fabrics (E1 and W1). S14 showed better results in term of strength and extensibility in MD. It was because of the better entangling behaviour of the fibres and the greater number of fibres per unit area of the fabric compared to S3 and S4. There were strong fibre to fibre frictional forces in S14 samples that resisted the disentangling action of the applied load due the maximum fibre alignment in the machine direction. According to Moyo et al (107) the tensile strength of the fabric depends on the arrangement of the fibres and therefore the maximum tensile strength is achieved in the direction of alignment of fibres. Sample S14 showed the highest coherence in its structure and the fibres were aligned in the machine direction, therefore, it was easier to transfer the external load from one fibre to another, which led to the highest observed tensile strength in the machine direction. Samples S13 and S14 showed maximum breaking extension in CD as compared to S3, S4, E1 and W1 as shown in Figure 4.68.

From the comparison of the various fabric samples tested, it can be concluded that the fabric sample S14 fabric showed the best possible combination of tensile properties and it may be suitable for apparel applications. Furthermore, the properties of S14 can be further enhanced by employing appropriate finishing processes, such as thermal bonding and calendaring.



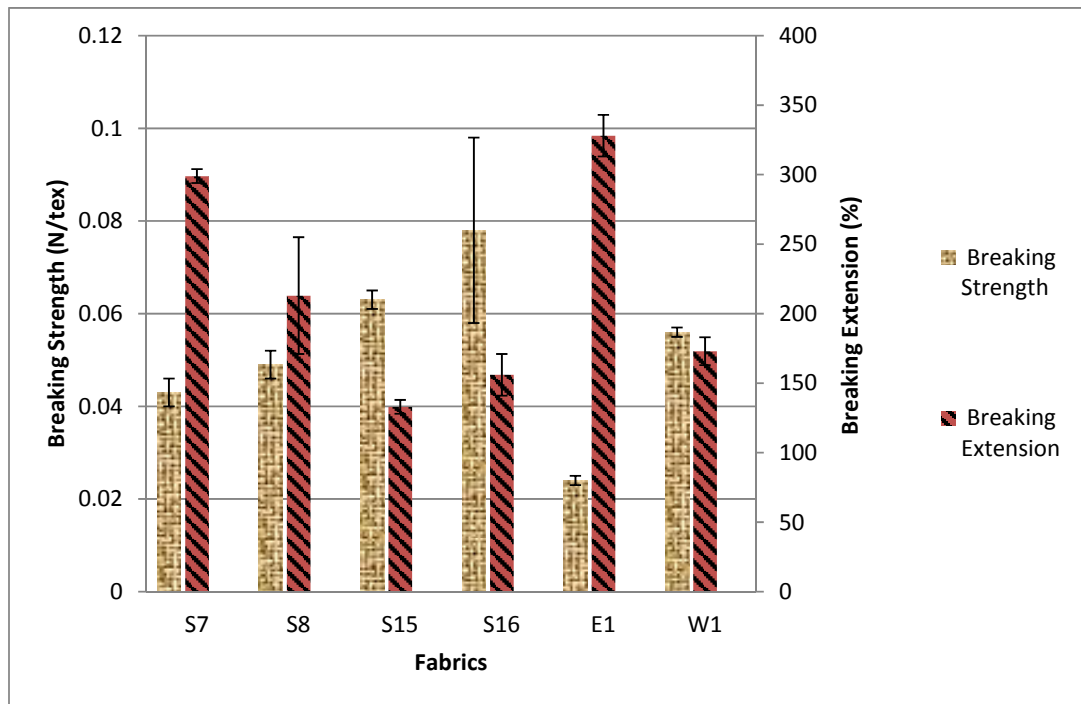
**Figure 4.68** Comparison of tensile strength in CD of hydroentangled nonwoven fabrics produced at different hydro pressures with commercial nonwoven and woven fabrics



#### 4.2.13.1 Comparisons of developed hydroentangled thermal bonded nonwoven fabrics with commercial hydroentangled and woven fabrics

The developed fabrics samples from S7, S8, S15 and S16 were subjected to the thermal bonding process. The results presented in Figure 4.69 show that after thermal bonding, the tensile strength in MD of all the developed hydroentangled fabrics increased. The increase in the tensile strength in MD was 15%, 19%, 9% and 5% for samples S7, S8, S15 and 16, respectively. However, a decrease in the breaking extension was observed for most of the developed hydroentangled fabrics.

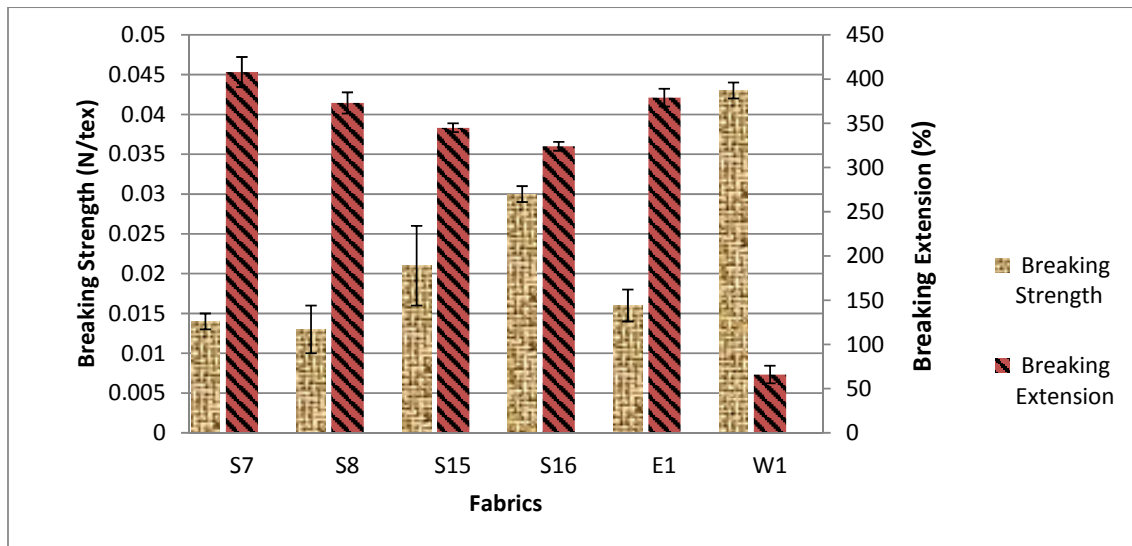
Thermal process mainly affected the fabrics produced directly from the hydroentanglement process as shown in Figure 4.69. The fabric sample S16 showed lower breaking extension as compared to the E1 (commercial hydroentangled nonwoven fabric) but it showed higher strength in the MD. S16 also showed higher strength in the MD, which was very similar to the breaking strength of the woven fabric (W1).



**Figure 4.69** Comparisons of tensile strengths in MD of hydroentangled thermal processed nonwoven fabrics produced at different hydro pressures with commercial hydroentangled and woven fabrics

The tensile properties of all the developed thermally bond nonwovens and the commercial fabrics in the CD are illustrated in Figure 4.70. The results show that the tensile strength of sample S16 is better than the all samples tested apart from w1 and E1, and its breaking extension is similar to the woven fabric (W1). When compared with the commercial nonwoven fabric (E1), S16 had considerably higher tensile strength, however, the breaking extension value was much lower than E1.

It can be concluded that after the thermal bonding process, the developed hydroentangled fabrics show tensile strength, which is superior to the commercial nonwoven and woven fabrics. The results for the thermally bonded S16 show the tensile characteristics of this fabric are similar to the woven fabric and therefore the fabric may be suitable for apparel applications.



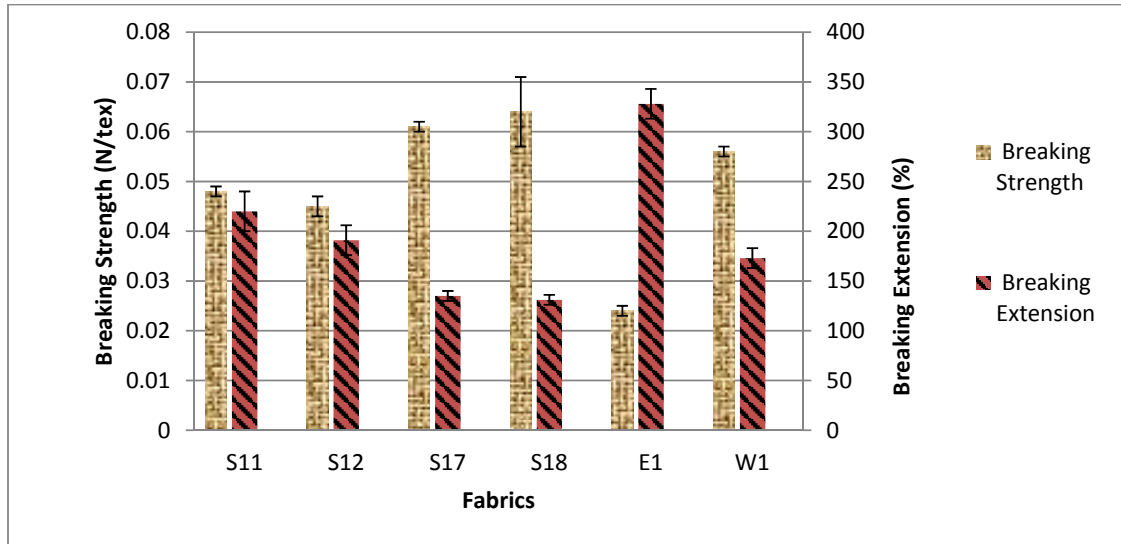
**Figure 4.70** Comparison of tensile strength in CD of hydroentangled thermal processed nonwoven fabrics produced at different hydro pressures with commercial hydroentangled and woven fabrics

**4.2.13.2 Comparisons of developed hydroentangled calendared processed nonwoven fabrics with commercial hydroentangled and woven fabrics**

The results presented in Figure 4.71 show that the calendaring process reduced the tensile strength and breaking extension of the developed hydroentangled fabrics in the machine direction. This is because during the calendaring process the roller pressure (1 ton) and the elevated temperature (110-115<sup>0</sup>C) can result in some fibre damage, which reduces tensile strength of the fabric. The tensile strength of S18 fabric sample

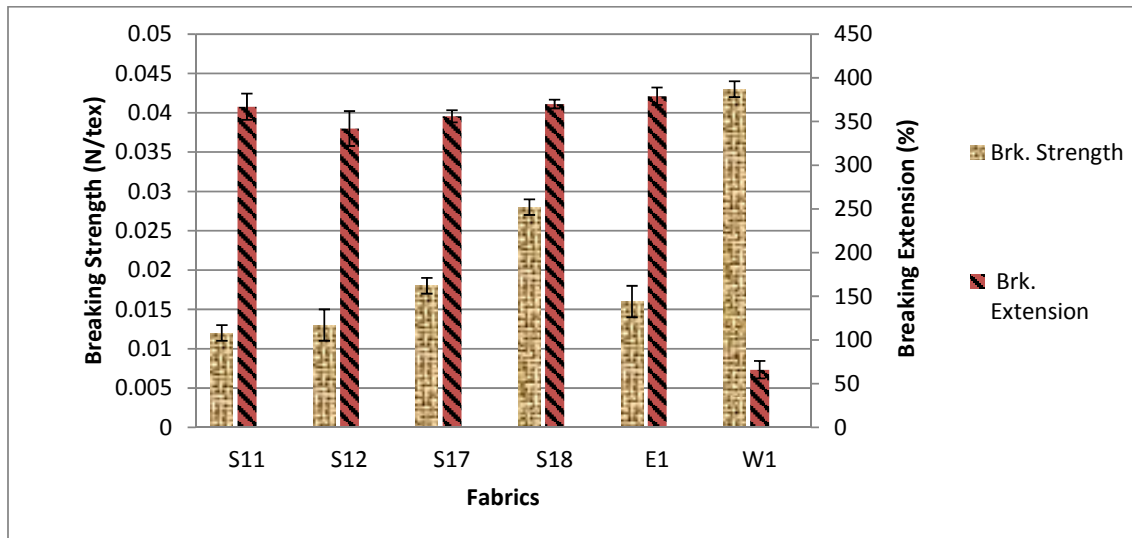
was reduced by 18% from 0.078 N/tex to 0.064 N/tex in the MD and its breaking extension was also reduced by 16% as compared to the thermally bonded sample.

A comparison of the tensile strength of the calendared S18 sample with E1 fabric (commercial nonwoven) and W1 (woven) is presented in Figure 4.71, which shows that the calendared S18 exhibits higher MD strength than E1 and W1. Furthermore, the breaking extension value of the calendared S18 is very similar to W1.



**Figure 4.71** Comparison of tensile strength in MD of hydroentangled calendared processed nonwoven fabrics produced at different hydro pressures with commercial hydroentangled and woven fabrics

Calendaring process reduced the tensile strength of the developed hydroentangled fabrics in the CD and increased their breaking extension, as discussed earlier. However, the CD strength of the calendared S18 fabric was higher than that of E1 and W1, while the breaking extension in CD was lower than E1 and higher than W1. The calendaring process also has a significant effect on the physical appearance of the fabric, such as its hand feel and fall of the fabric.



**Figure 4.72** Comparison of tensile strength in CD of hydroentangled calendared processed nonwoven fabrics produced at different hydro pressures with commercial hydroentangled and woven fabrics

A comparison of the tensile properties of all the samples studied show that the developed nonwoven sample S18 exhibited a good balance of tensile strength and breaking extension. Its performance was similar to the woven sample (w1) and much superior to the commercial nonwoven E1. Therefore, it appears that S18 has useful tensile characteristics for apparel applications, at least for the single use garment.

#### 4.2.14 Air permeability

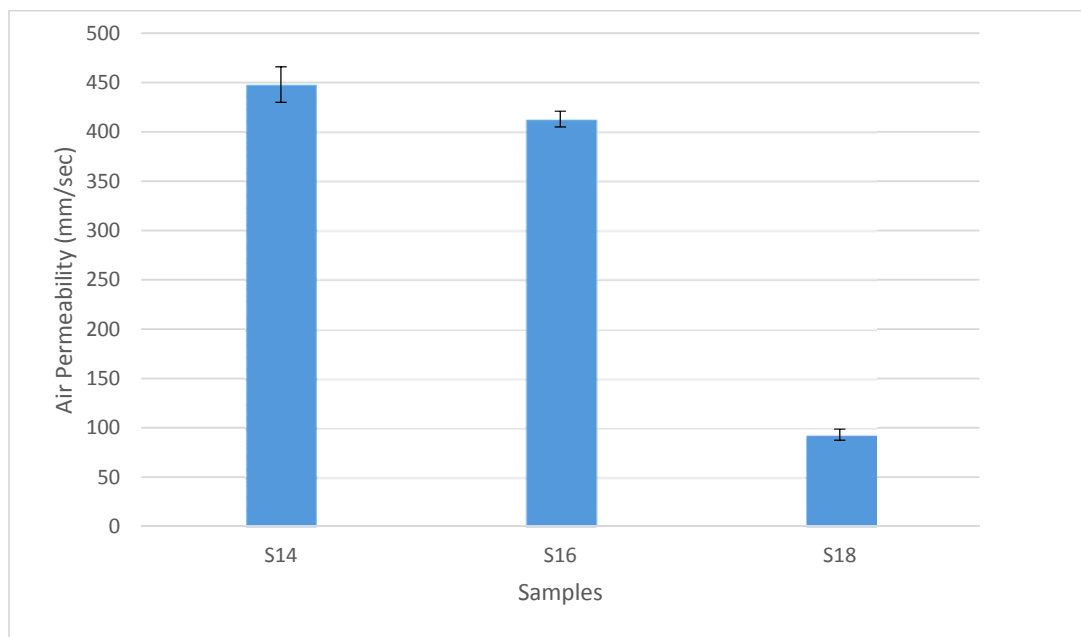
The air permeability results for the various fabrics tested are given in Table 4.15 and illustrated in Figure 4.73. The basic characteristics of these fabrics are listed in Table 4.16. The hydroentangled nonwoven S14 fabric produced at 125 hydro pressure with pre-needling was tested before and after finishing processes and the results were compared with the commercial hydroentangled and woven fabrics.

**Table 4.15** Air Permeability values of the developed hydroentangled nonwoven and references fabric samples at 100 Pa and the area was 20 cm<sup>2</sup>

<b>S#</b>	<b>Values</b>				<b>Mean (mm/Sec)</b>
<b>S14</b>	430	463	468	429	<b>448</b>
<b>S16</b>	404	415	407	425	<b>413</b>
<b>S18</b>	100	90	95	85	<b>93</b>
<b>E1</b>	62	74	78	63	<b>69</b>
<b>W1</b>	443	491	449	462	<b>461</b>

**Table 4.16** Characteristics of the developed hydroentangled nonwoven and reference fabrics samples

Fabric I.D.	Composition (%)	Area weight (g/m <sup>2</sup> )	Thickness (mm)	Fabric Type	Bulk Density
S14	70 Tencel 30 bicomponent, sheath/core, PE/PET	150±5	0.88	Hydroentangled and Pre-needled @ 125 bars	0.174
S16	70 Tencel 30 bicomponent, sheath/core, PE/PET	150±5	0.88	Hydroentangled @ 125 bars (Pre-needled) and thermal bonded (infra red)	0.174
S18	70 Tencel 30 bicomponent, sheath/core, PE/PET	150±5	0.86	Hydroentangled @ 125 bars (Pre-needled) and calendared	0.173
E1	70% PET/ 30% PA 6	140	0.43	Spunlaid/ Hydroentangled	0.326
W1	100 Cotton	144	0.50	Woven	0.3



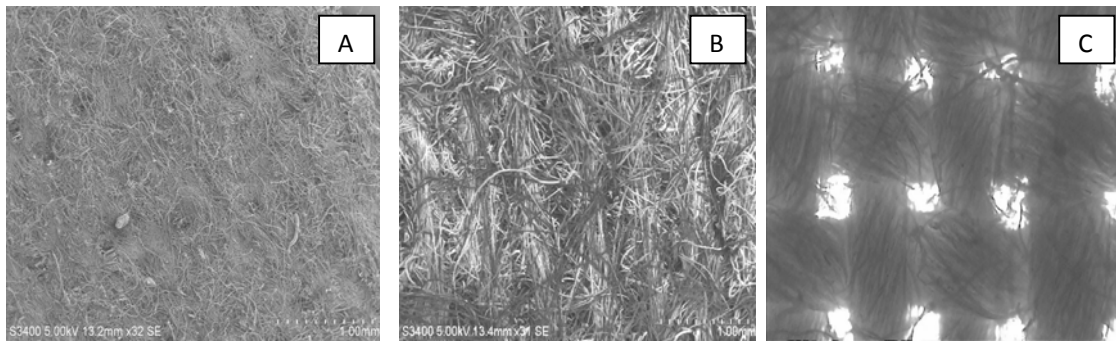
**Figure 4.73** Effects of finishing processes on the air permeability values of the hydroentangled nonwoven fabrics produced at 125 bars hydro pressure.

The results (Table 4.15 and Figure 4.73) show that sample S14 (unfinished fabric) exhibited air permeability values that are higher than the finished samples S16 and S18. S16 fabric was finished with the thermal process and it was noticed that after the thermal process, the air permeability values were reduced to 413 mm/sec from 448 mm/sec. It was because of the melting the bicomponent fibres within the region of the fabric. Table 4.16 shows that the developed hydroentangled fabric consisted of Tencel and bicomponent sheath/core PE/PET fibres. Because of the melting of the sheath part of the bicomponent fibres thermal bonding were created within the structure of the fabric that reduced the porosity of the fabric, which caused the reduction in the air permeability values after the thermal process, as illustrated in Figure 4.73.

The calendared sample (S18 fabric) exhibited the lowest air permeability values because during calendaring process the heat and pressure of the rollers melted the bicomponent fibres, which created a thin layer of the melted polymer (PE) within the structure of the fabric. This led to a considerable decrease in the porosity of the fabric thus reducing the air permeability value of the fabric. The calendaring process resulted in almost 80% reduction in the air permeability of the fabric, if compared with sample S14. The pore structure of the fabric has a direct effect on the air permeability. The air permeability increases as pore size increases and pore structure depends on

different parameters such fibre fineness, bonding techniques and finishing processes.  
(77)

Sample S14 also exhibited higher air permeability value as compared to the commercial nonwoven fabric (E1) and the value of S14 is similar such as s14 showed 448 mm/sec air permeability that is close to the value of woven fabric that was 461 mm/sec as mentioned in Table 4.15. E1 hydroentangled fabric is produced through the spun laying and hydroentanglement processes by using the island-in-the-sea bicomponent PET and PA6 ultra-fine micro fibrils filaments. The spunlaying process leads to a very close fabric structure, which hinders the passage of air through the fabric (Figure 4.74 A). On the other hand, woven fabric (W1) has an organised structure, which depends on the warp and weft yarn, and the fabric is more porous as compared to the other fabrics (Figure 4.74 C). These pores enhance the air permeability properties of the woven fabric.

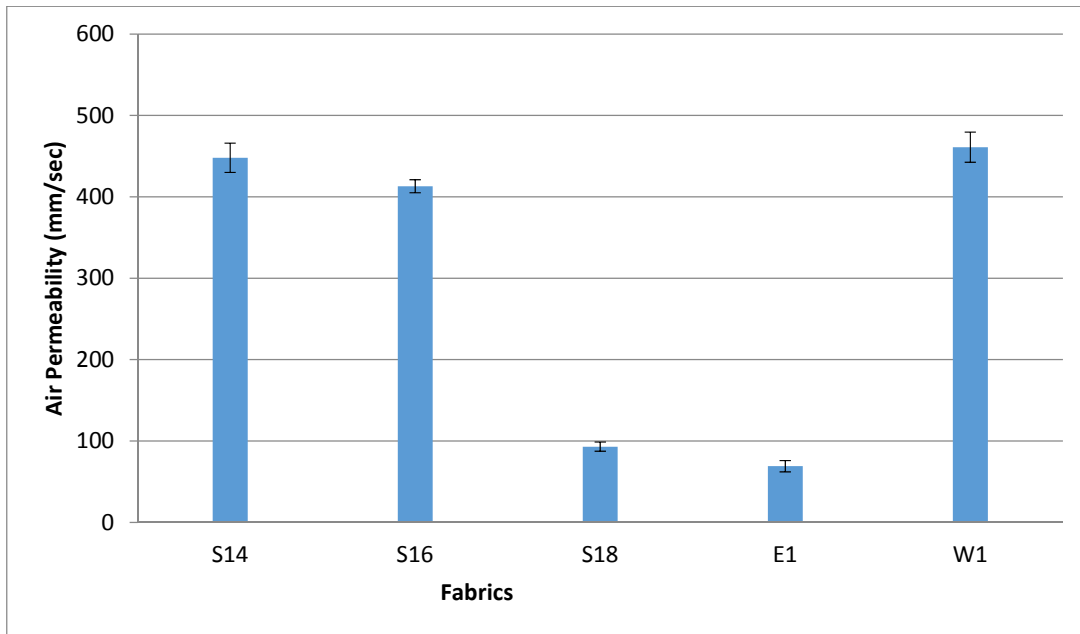


**Figure 4.74** Topical view of commercial hydroentangled (A), developed hydroentangled (B) and woven (C) fabric structures obtained by SEM at 1mm size.

Figure 4.74B shows that developed hydroentangled fabrics structure is porous and having loose structure as compared with the commercial hydroentangled fabric. It can be seen in Table 4.16 that the thickness of the developed hydroentangled fabric is 0.88 mm and that of the commercial hydroentangled fabric is 0.43 mm. Therefore, the commercial hydroentangled fabric has a more compact structure than the developed hydroentangled fabric and as a result it is expected to exhibit lower value of air permeability.

It can be seen in Figure 4.75 that on the basis of the fabric structures, the developed hydroentangled fabric exhibited better results than commercial hydroentangled fabric. As mentioned earlier, fabric E1 is composed of ultra-fine micro fibrils, which means

there are more fine filaments per unit area of the fabric because of the presence of ultra-fine filaments. This excess presence of micro filaments per unit area reduces the porosity of the fabric, which causes a reduction in the air permeability value of the fabric as shown in Figure 4.75. Fabric mass per unit area and consolidation of the fabric also have major effect on the air permeability of nonwovens, as the mass per unit area increases due to the presence of more fibres per unit area of the fabric there will be less space between the fibre for air circulation. (78)



**Figure 4.75** Comparison of air permeability values of developed hydroentangled nonwoven fabrics with commercial hydroentangled and woven fabrics

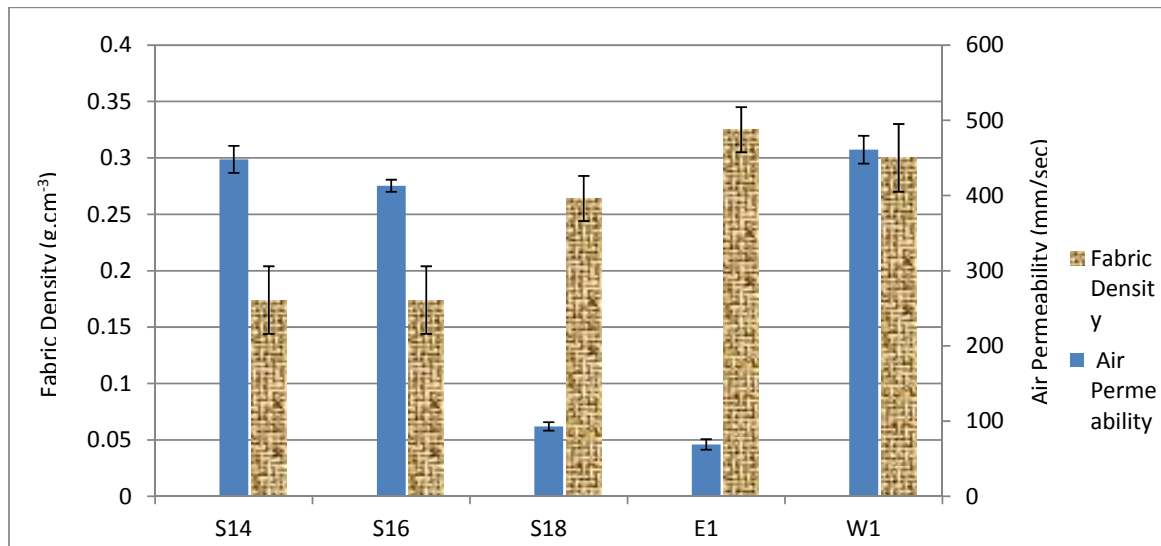
Figure 4.76 demonstrates that the higher density of the nonwoven fabric leads to a reduction in the air permeability values but in case of woven fabric higher density did not affect the air permeability values of the fabric. It can be seen in Figure 4.76 that S18, E1 and W1 showed higher densities but S18 and E1 showed lower air permeability values than W1. Basically, here fabrics manufacturing patterns differ from each other, commercial available hydroentangled nonwoven fabric is produced through the spunlaying and hydroentanglement technology and woven fabric produced through the weaving process.

S18 fabric is a calendared nonwoven and as result of the pressure roller action the fibres were forcefully pushed close each other and tightly bonded within the structure of the fabric. This led to the increase the number of fibres per unit area of the fabric



and it also reduced the thickness of the fabric to 58 mm from 88 mm. Furthermore, low melt bicomponent fibres created strong thermal bonding within the structure of the fabric that resisted the air through the fabric. Because of these reasons sample S18 showed the lowest air permeability values of all the fabric samples tested with the exception of E1.

Second, the minimum air permeability value of developed hydroentangled exhibited by S18 which was calendared sample but, it still showed higher values if compared with the commercial hydroentangled nonwoven fabric as shown in Figure 4.76.



**Figure 4.76** Effect of fabric density on air permeability of fabrics tested

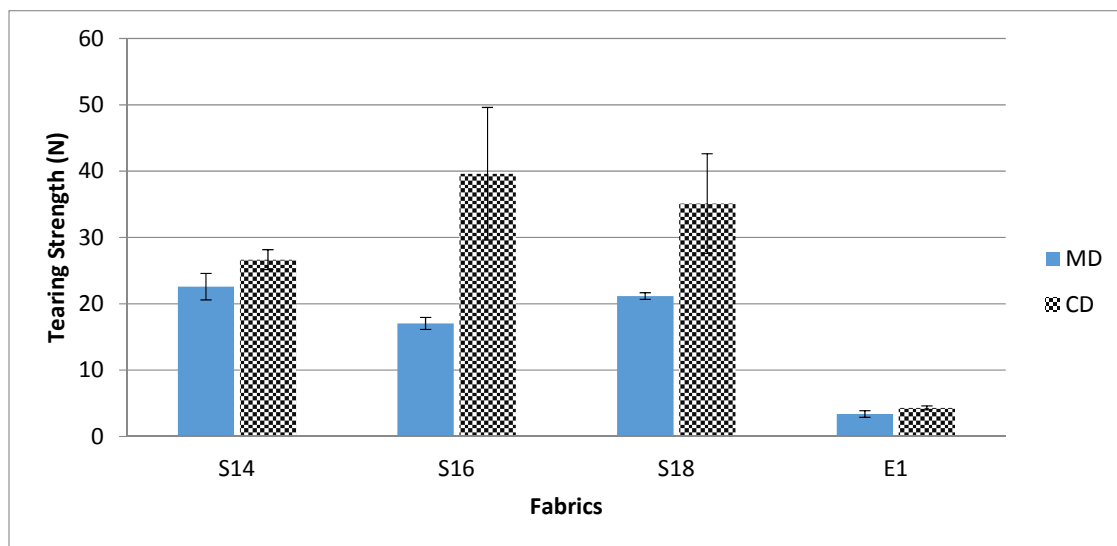
#### 4.2.15. Tearing test

Amongst the important mechanical properties of a fabric is its tearing strength, which is a sign of the serviceability of the fabric (149). The developed hydroentangled nonwoven fabric produced at 125 bars hydro pressure was tested according to the ASTM 5734 standard by using Elmendorf tester. The results of the tested fabrics were compared with the control commercial hydroentangled fabric (Table 4.17).

**Table 4.17** Tearing strength values of developed and control fabrics in machine and cross directions.

Sample I.D.	Fabric Nature	Fibre Contents	Force in grams (g)		Force in Newton (N)	
			CD	MD	CD	MD
S14	Hydroentangled @125 bars	70% Tencel and 30% sheath/core, PE/PET, Bicomponent	2720	2304	26.66	22.58
S16	Hydroentangled and Thermal processed	70% Tencel and 30% sheath/core, PE/PET, Bicomponent	4042.67	1738.67	39.61	17.04
S18	Hydroentangled and Calendared	70% Tencel and 30% sheath/core, PE/PET, Bicomponent	3584	2160	35.12	21.16
E1	Commercial Hydroentangled	70% PET and 30% PA6 , island in the sea micro fibrils, Bicomponents	440	346.13	4.31	3.39

The results presented in Table 4.17 show that fabric S16 exhibited the maximum tearing strength in CD as compared to the other developed and commercial fabrics. It is the thermal bonding raises the tearing strength of the fabric. The melted bicomponent fibres create flexible thermal bonding with its surrounding fibres, which increases the fabric's resistance to the external tearing force. According to Lord et al (150), the tearing strength could be reduced if the yarn movement is restricted within the fabric structure. Therefore, it seems that the thermal bonding process creates flexible intra fibre bonds that do not restrict fibre movement within the fabric, while providing enough resistance to hold the fabric structure intact.



**Figure 4.77** Tearing strength of developed hydroentangled nonwoven fabrics produced at 125 bars and compared with commercial hydroentangled nonwoven fabric.

It can be seen in Figure 4.77 that the tearing strength was increased from S14 to S16 in the CD then decreased for sample S18. All of the developed fabrics (S14, S16 and S18) were produced at same hydro pressure 125 bars, but S16 fabric was thermal bonded and S18 fabric was calendared after the hydroentanglement process. S18 fabric showed lower tearing strength than S16 in the CD, it was because of the calendaring action, as the fibres were not able to move freely within the structure of the fabric and thus causing a reduction in the tearing for sample S18.

Commercial hydroentangled fabric showed lower value of tearing strength as compared to the developed fabrics. Such as S16 exhibited 36.61 N tearing strength in CD, which was 89% higher than the commercial hydroentangled fabric (E1) which possessed tearing strength of 4.31 N in the CD. The tearing strengths of all the developed hydroentangled fabrics are similar and with small differences in the CD.

It is known that during hydroentanglement process, fibres are bonded through mechanical force by twisting of the fibres around their neighbouring fibres. The mechanical force creates frictional force between the fibres and because of the structure of Tencel fibre these frictional forces do not restrict the fibre movement in the fabric structure and resulting in good tearing strength of the developed hydroentangled fabrics. According to Kotb et al (151), reduced frictional constrains allow the yarns to bunch at the tear.

On the other hand commercial hydroentangled nonwoven fabric exhibited lower tearing strength values than all developed hydroentangled fabrics in the machine and cross directions. This is mainly due to the structure of the commercial hydroentangled fabric, which is a spunlaid hydroentangled fabric in which the filaments are bonded strongly and are not able to move within the structure of the fabric. Secondly, the commercial hydroentangled fabric is made composed of fine fibrils that also cause a reduction in the tearing strength of E1.

The tearing resistance (TR) values shown in Table 4.18 were also found to be similar to the tearing strength values. Tearing resistance was calculated by using the following relationship:

$$TR = \text{Force (N)} / \text{Thickness (mm)}$$

Tearing resistance is the ratio of tearing force and the thickness values of the fabrics. This is a standard method that provides the same scale to calculate the tearing force that is comparable. Table 4.18 and Figure 4.78 show that the commercial hydroentangled nonwoven fabric (E1) exhibited the lowest value of tearing resistance as compared to the developed hydroentangled fabrics (S14, S16 and S18).

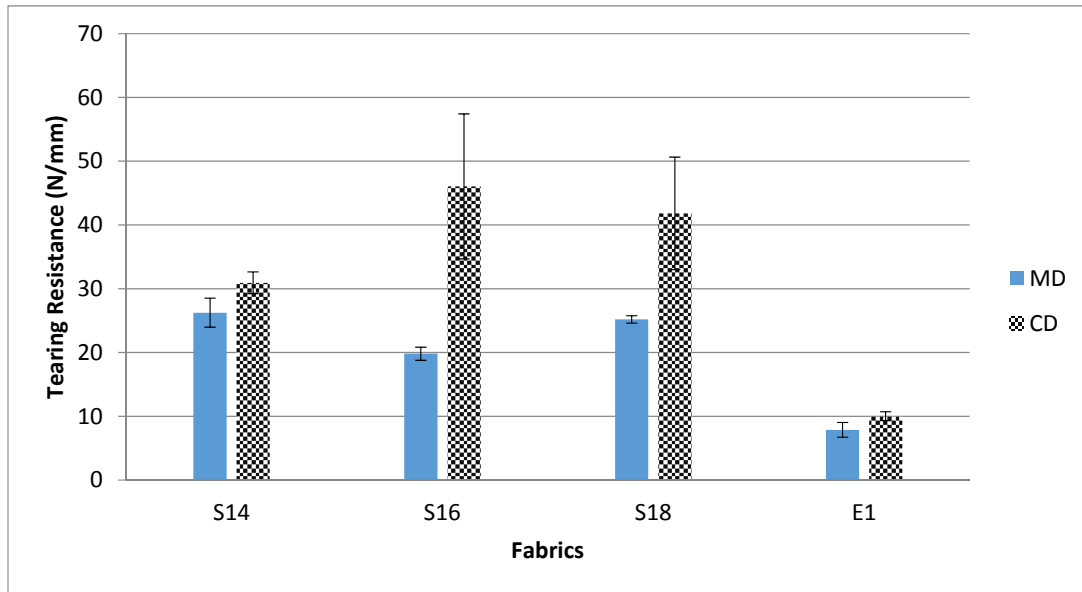
**Table 4.18** Tearing resistance values of developed and control fabrics in machine and cross directions

Sample I.D.	Fabric Nature	Fibre Contents (%)	Tearing Strength (N)		Thickness (mm)	Tearing Resistance (N/mm)	
			CD	MD		CD	MD
S14	Hydroentangled@125 bars	70% Tencel and 30% sheath/core, PE/PET, Bicomponent	26.66	22.58	0.88	30.94	26.25
S16	Hydroentangled and Thermal processed	70% Tencel and 30% sheath/core, PE/PET, Bicomponent	39.61	17.04	0.88	46.06	19.81
S18	Hydroentangled and Calendared	70% Tencel and 30% sheath/core, PE/PET, Bicomponent	35.12	21.16	0.85	41.81	25.19
E1	Commercial Hydroentangled	70% PET and 30% PA6, island in the sea micro fibrils, Bicomponent fibres	4.31	3.39	0.43	10.02	7.88

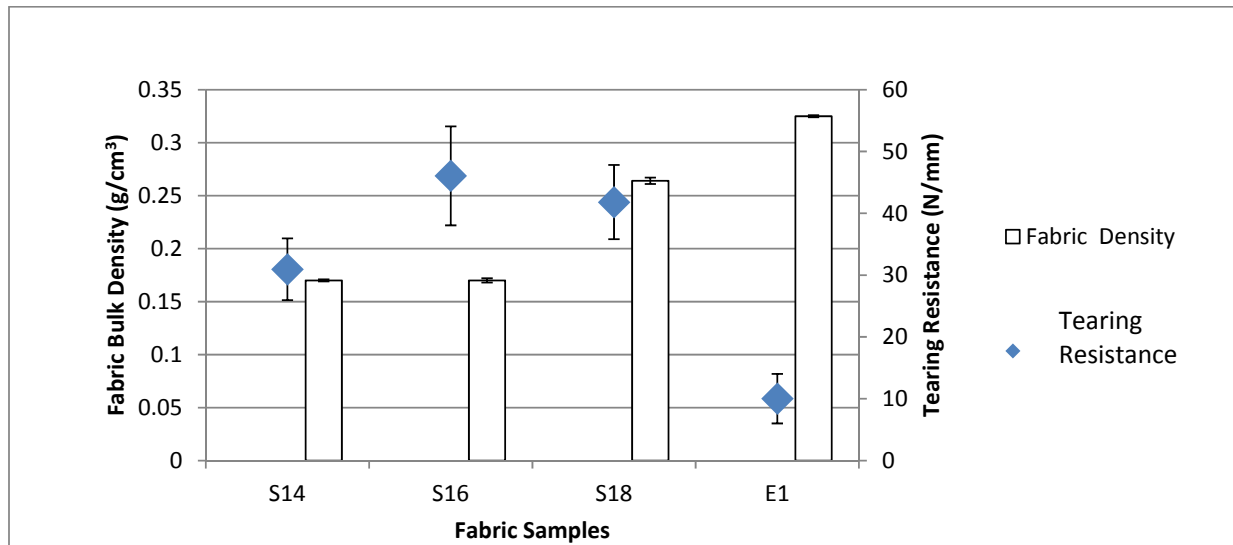
The fabric density also affect the tearing resistance of the fabric as shown in Figure 4.79. Fabric bulk densities of samples S14 and S16 were the same (170 g/cm<sup>3</sup>) but

after the calendaring process, the density of fabric S18 was increased to  $0.264 \text{ g/cm}^3$ , which reduced the tearing resistance by 11% in CD as compared to the thermally bonded S16 fabric.

During calendaring process the thickness of the fabric was also reduced from 0.88mm to 0.85mm, which increased the bulk density of the fabric but reduced the tearing resistance in the CD. E1 fabric exhibited higher bulk density but showed lower tearing resistance in the CD as compared to the developed hydroentangled fabrics S14, S16 and S18. As it has been discussed earlier, the fibre type and fabric structure play important roles in enhancing the tearing resistance of the fabric. Fabric S16 showed higher tearing strength while having lower bulk density as compared to S18 and E1. This is mainly due to the flexible structure of the fabric S16 where fibres had the ability to move within the fabric structure. Secondly, fabric S16 was prepared by using fibres with dtex 0.9 that is much higher than the fibrils that were used in the production of the commercial hydroentangled fabric (E1).



**Figure 4.78** Tearing resistance of developed hydroentangled nonwoven fabrics produced at 125 bars and compared with commercial hydroentangled nonwoven fabric.

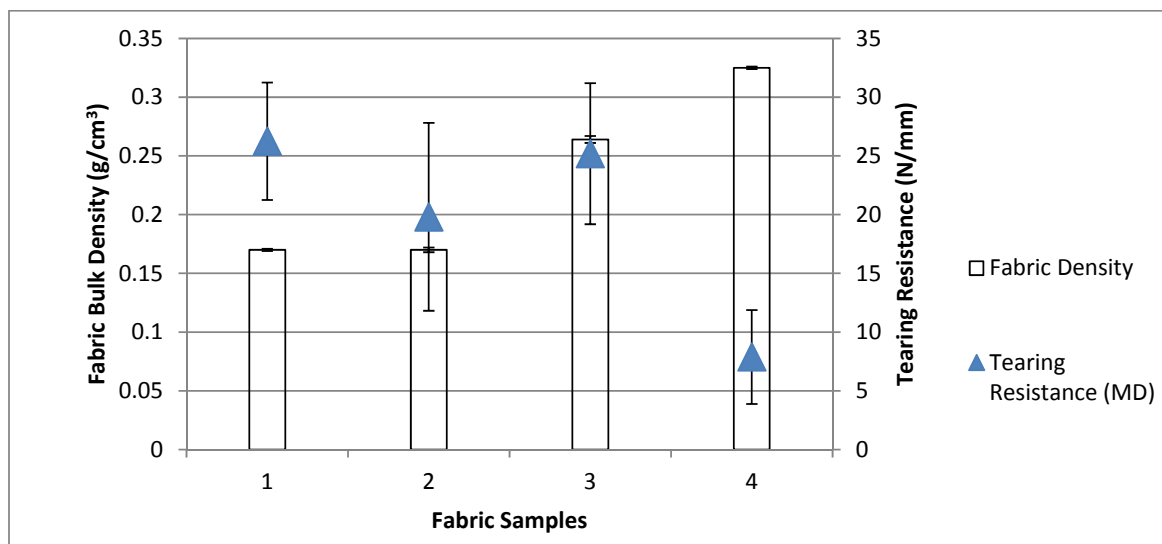


**Figure 4.79** Effect of fabric bulk density on tearing resistance of developed and commercial hydroentangled nonwoven fabric with fabric density in CD

The tearing resistance of fabric without out thermal bonding (S14) was 26.25 N/mm but after the thermal processing (S16) the fabric exhibited lower tearing resistance in the MD, which is quite an anomalous behaviour of the fabric as compared to the effect in the CD (Figures 4.79 and 4.80), where the tearing resistance of the fabric was increased after the thermal bonding process. This may be due to the fact that the number of bicomponent fibres in the MD region of the fabric was lower and during the thermal bonding processing the extent of bonding was insufficient to provide adequate strength, which caused a reduction in the tearing resistance in MD region.

The results presented in Figure 4.80 also show that after the calendaring process fabric S18 exhibited higher tearing resistance in the MD (25.19 N/mm) as compared to the thermally bonded fabric S16 (19.81 N/mm). The calendaring rollers pressed the fibres and pushed them within structure of the fabric, which enhanced the bulk density of the fabric and the number of fibres was increased in the MD, thus an increase in the tearing resistance in the MD was obtained after the calendaring process. The commercial nonwoven fabric (E1) showed low but similar tearing resistance values both in the machine and cross machine directions because of its isotropic structure.

Finally, it can be conclude that the developed hydroentangled fabrics (S14, S16 and S18) exhibited higher tearing resistance than the commercial hydroentangled fabric (E1) in the machine and cross machine directions.



**Figure 4.80** Comparison tearing resistance of developed and commercial hydroentangled nonwoven fabric with fabric density in MD

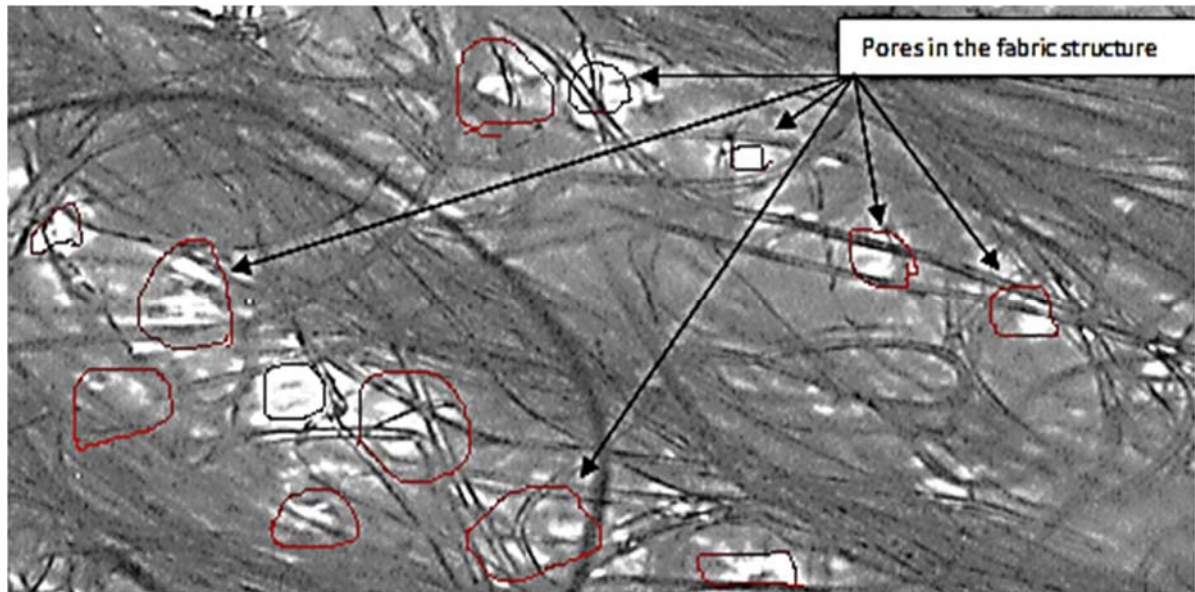
#### 4.2.16. Thermophysiological properties of developed hydroentangled nonwoven fabrics

##### 4.2.16.1 Thermal absorptivity (Dry)

One of the fundamental functions of the clothing is to maintain thermal balance of the body, which depends on many factors including the textile material, environment and the clothing structure. Fabrics with the lower thermal absorptivity values give “warm” feeling (85,155). The results presented in Table 4.19 show that the developed hydroentangled fabric (S14) has lower value of thermal absorptivity in the dry condition as compared to the commercial nonwoven and woven reference fabrics. There were appear to be two main reasons that the developed fabric showed lower value of heat absorption. Firstly, the developed nonwoven fabric has a porous structure (Figure 4.81) and dead air can be trapped in the pores, which provides resistance to transfer from the fabric to the environment. Secondly, the thickness of the developed nonwoven fabric is higher than both the reference fabrics. It was observed by Frydrych et al (85) that heat diffusion depends on the thickness of the fabric because the heat waves spend more time in a thicker fabric than in a thinner fabric structure. The heat transfer process through the fabric depends on three mechanisms, which are conduction, convection and radiation but the more significant is the conduction (152).

**Table 4.19** Comparison of thermal absorptivity of developed hydroentangled fabric with commercial and reference fabrics

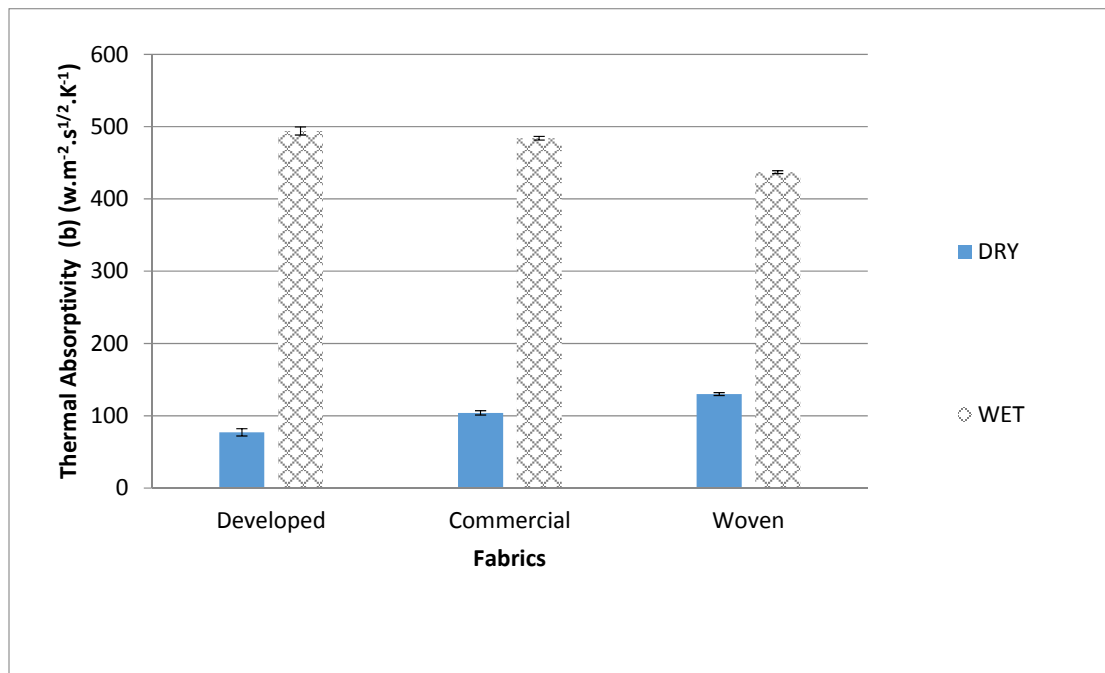
S#	Fabrics	Thickness @ 5 g/cm <sup>2</sup> (mm)	Wt. g/m <sup>2</sup>	Density g/cm <sup>3</sup>	DRY		WET		% of loss in warmth to touch	% of recovery after 4 min wetting
					b (w.m <sup>-2</sup> .S <sup>1/2</sup> . K <sup>-1</sup> )	r (K.m <sup>2</sup> .W <sup>-1</sup> )	b (w.m <sup>-2</sup> .S <sup>1/2</sup> . K <sup>-1</sup> )	r (K.m <sup>2</sup> .W <sup>-1</sup> )		
1	Developed nonwoven (S14)	0.86	150	0.174	77	23.7	494	9.8	541%	44.58%
2	Commercial nonwoven (E1)	0.43	140	0.325	104	20.9	484	7.7	365%	36.8%
3	Woven	0.48	144	0.300	130	20.4	437	7.0	226%	34.31%



**Figure 4.81** Microscopic image of hydroentangled fabric produced at 125 bars hydro pressure.

On the other hand, reference plain woven fabric showed the highest dry thermal absorption value because of its systematic fabric weave and lower thickness value. The Commercial hydroentangled nonwoven exhibited thermal absorptivity value of 104 w.m<sup>-2</sup>.S<sup>1/2</sup>. K<sup>-1</sup>, which is was higher than the developed hydroentangled fabric (77 w.m<sup>-2</sup>.S<sup>1/2</sup>. K<sup>-1</sup>) and lower than the reference woven sample (130 w.m<sup>-2</sup>.S<sup>1/2</sup>. K<sup>-1</sup>).





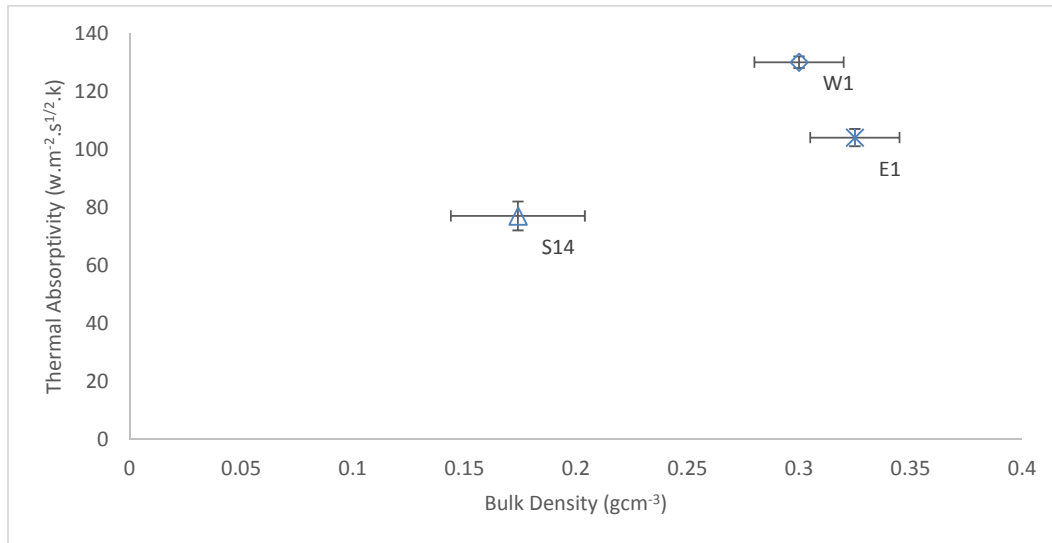
**Figure 4.82** Thermal absorptivity of developed hydroentangled, commercial nonwoven and woven fabrics in dry and wet states.

Firgo et al (115) found that the thermal absorptivity of 100 % Tencel fibre was higher than that of 100% cotton fibre and an increase in the thermal absorptivity of Tencel fibre was observed as the air humidity was increased. The hydroentangled fabric developed in this study is composed of 70% Tencel and 30% bicomponent sheath/core PE/PET fibre and it is the addition of the bicomponent fibre in the developed hydroentangled fabric that lowered thermal absorption of the fabric, as shown in Figure 4.82.

In a compact structural material, the heat transfer occurs by the conduction through fibres (152). Based on this theory, as expected, in the dry state the commercial nonwoven and reference woven fabrics exhibited thermal absorption values that are higher than the developed hydroentangled fabric (Table 4.19). The developed hydroentangled has loose structure in which the air is trapped in the fabric interstices, resulting in a decrease in the conduction of heat within the developed hydroentangled fabric. Snezana et al (152) found that heat transfer is also affected by the morphology and structure of the fibre. More crystalline fibres give better heat conduction, and it is also noted that commercial hydroentangled fabric consisted of polyester and nylon fibres and it is noted that polyester shows higher crystallinity due to which the commercial nonwoven (E1) also has enhanced thermal absorptivity. These

researchers also demonstrated that the loose structure consisted of entrapped air, which acts as an insulating medium and thus slows down the transfer of thermal energy within the fabric. Milenkovic et al (153) found that the fabric thickness and entrapped air are the major factors that influenced the heat transfer from the body to the environment. The developed hydroentangled fabric exhibited has the highest thickness, and loose structure, therefore, it is expected to show the lowest thermal conductivity in dry condition.

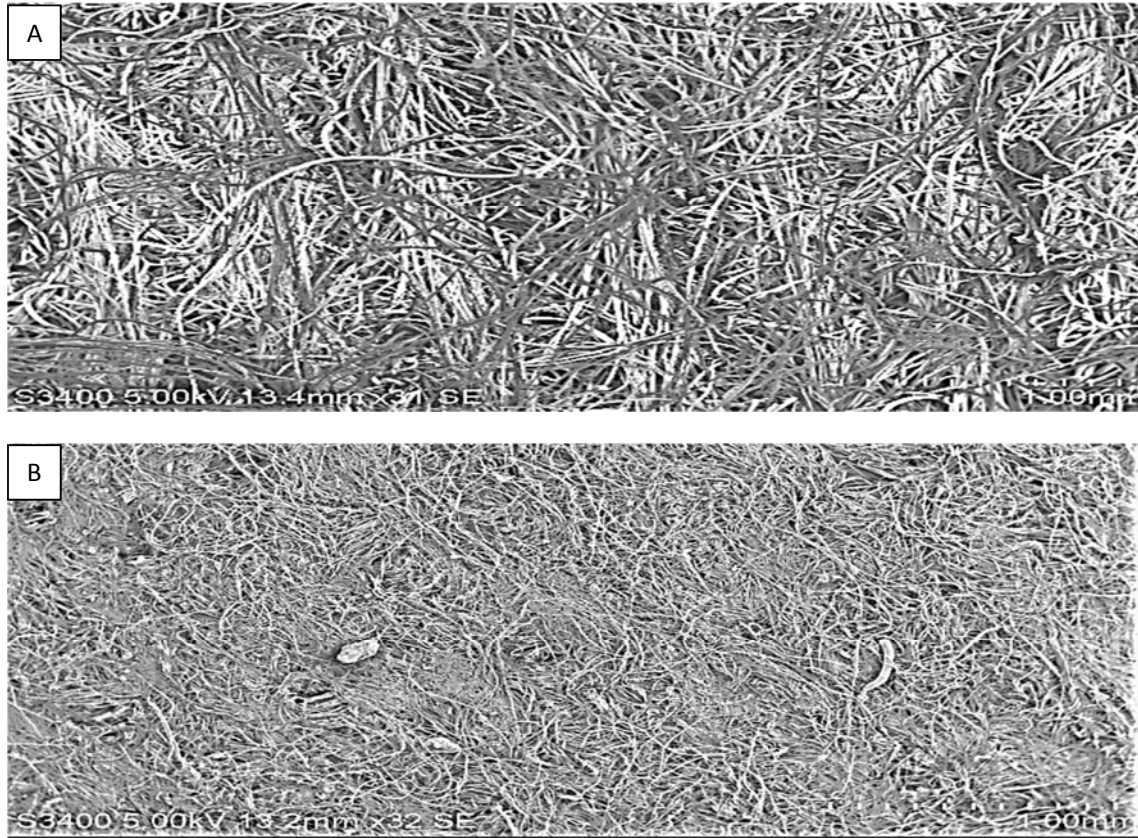
Fabric density also has a significant effect on its thermal absorptivity. Kandhavadiu et al (154) have demonstrated that as the amount of fibre per unit area of the fabric increases, the thermal conductivity of the fabric also increases. The fabric density has a direct effect on the thermal properties of the fabric. Figure 4.83 shows that the commercial hydroentangled fabric exhibited higher thermal absorptivity as compared to the developed hydroentangled fabric because of its higher fabric density. The highest value of thermal absorption was exhibited by the woven fabric. The woven fabric has a set pattern of weave with even distribution of pores and compactness, this helps in uniform conduction of heat by the fabric.



**Figure 4.83** Effect of fabric density on the thermal absorptivity of the developed and commercial hydroentangled and woven fabric in dry condition

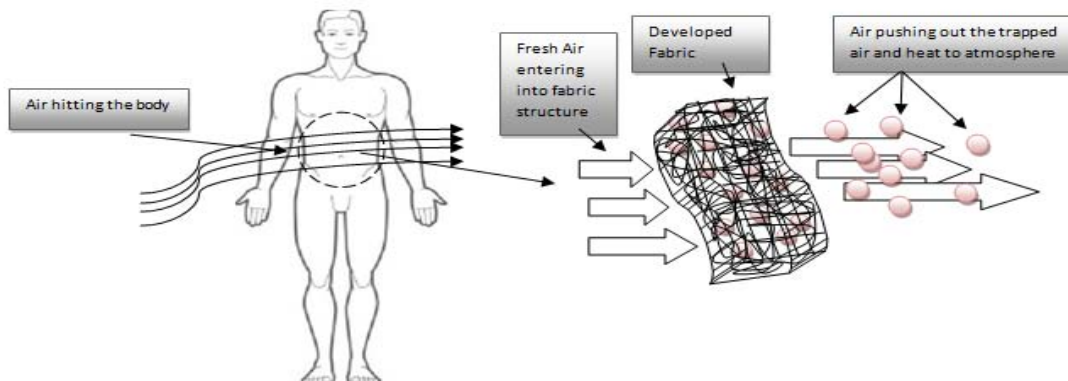
Figure 4.84 (A) shows that the commercial hydroentangled fabric had a compact structure, which enables the fabric to dissipate heat within structure more effectively. On the other hand, the developed hydroentangled fabric has a loose structure (Figure 4.84B) that helps to keep the air trapped inside the fabric structure, which reduces the

heat transfer from the fabric to the environment. Furthermore, the developed fabric (S14) has 30% bicomponent sheath/core PE/PET fibres and PE sheath has higher heat capacity and will absorb more heat and slow down the heat to transfer to the environment.



**Figure 4.84** SEM images of (A) developed (S14) and (B) commercial hydroentangled (E1) nonwoven fabrics

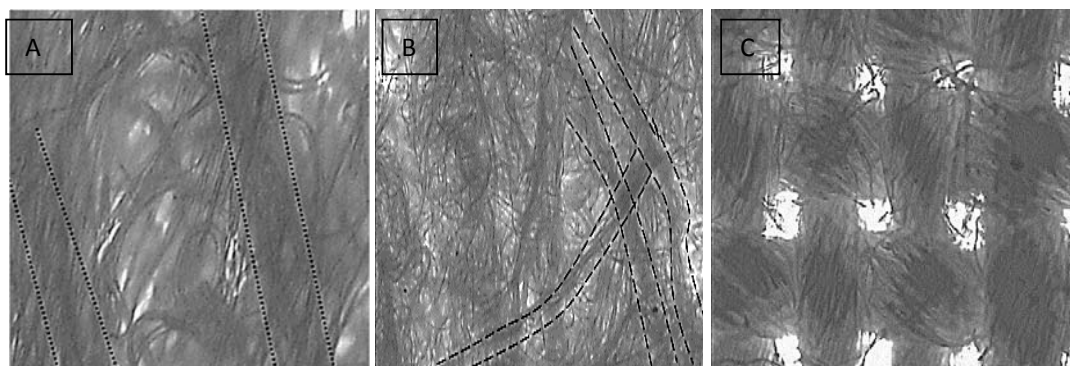
On the basis of these results, it can be concluded that the developed hydroentangled fabric keeps the body warm because of its low thermal absorptivity. However, because of its porous nature fresh air can enter the fabric structure and push the trapped air and transfer the heat into the environment during any physical activity, thus giving the body cooling effect and comfort, as illustrated diagrammatically in Figure 4.85.



**Figure 4.85** Thermal comfort model of developed hydroentangled fabric through air permeability process

#### 4.2.16.2 Thermal absorptivity (Wet)

Developed hydroentangled fabric exhibited higher thermal absorptivity in the wet condition as compared to the commercial nonwoven and woven fabrics as shown in Table 4.19 and illustrated in Figure 4.82. It was because of its higher wettability or absorption as compared to the other fabrics. Tencel fibres have higher water absorption rate than cotton (woven W1), and secondly, because of the fibril nature of Tencel fibres the absorption and dispersion of water within the fabric structure is enhanced. Water is highly conductive medium and has the capability to absorb heat from the body and transfer it to the environment.



**Figure 4.86** Structure of (A) developed nonwoven, (B) commercial nonwoven and (C) woven fabrics

The higher thermal absorptivity value of the developed hydroentangled fabric can be related to the presence of Tencel fibres and their fine structure. It can be seen in Figure 4.86 (A) that the developed fabric (S14), exhibited very fine porous structure with

strands, which act as capillaries and distribute the absorbed water within the fabric structure, due to which S14 shows high thermal absorptivity in the wet condition. The commercial hydroentangled fabric also showed higher absorptivity than the woven fabric. The commercial hydroentangled fabric (E1) is composed of bicomponent polyester and nylon filaments do not absorb the water inside the fibres, so they take the water from the body and transport it to the environment.

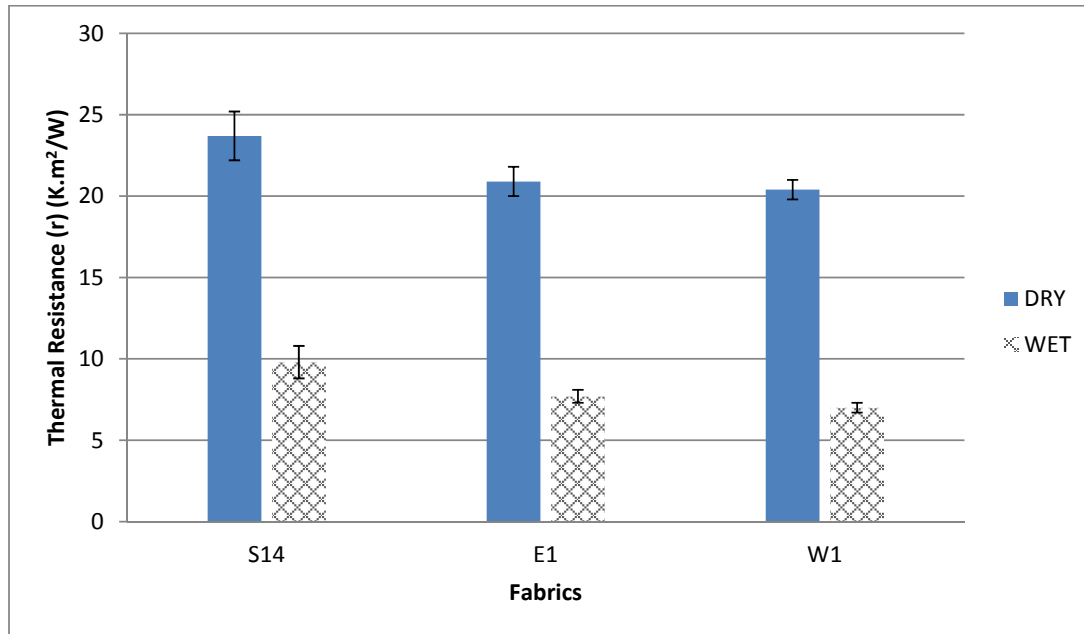
The lowest value of thermal absorptivity was shown by the woven fabric. Although, it is made of cellulose based fibres but because of its compact weave structure it exhibits low moisture absorption from the body effectively. Furthermore, because of its fine yarns, the fibres were not able to act as capillaries, due to which it showed lower values of thermal absorptivity in the wet condition.

Thermal absorptivity is a surface property and finishing processes can affect this property considerably (85). It can be seen in Table 4.20, that after the thermal bonding process, the thermophysiological properties changed such that the thermal absorptivity of the hydroentangled fabric (S14) was  $77 \text{ w.m}^{-2}.\text{S}^{1/2}.\text{K}^{-1}$ , but after thermal bonding process, the thermal bonded fabric (S16) showed higher value, that was  $84 \text{ w.m}^{-2}.\text{S}^{1/2}.\text{K}^{-1}$ . It was because of the presence of fewer air pockets within the fabric structure after the thermal bonding process. The nature of the surface of a fabric has a significant effect on warm-cool feeling, since a rougher fabric surface reduces the area of contact whereas a smoother surface increases the contact area thereby heat flow is increased, thus creating a cooler feeling to the body.

#### **4.2.17. Thermal resistance (Rct)**

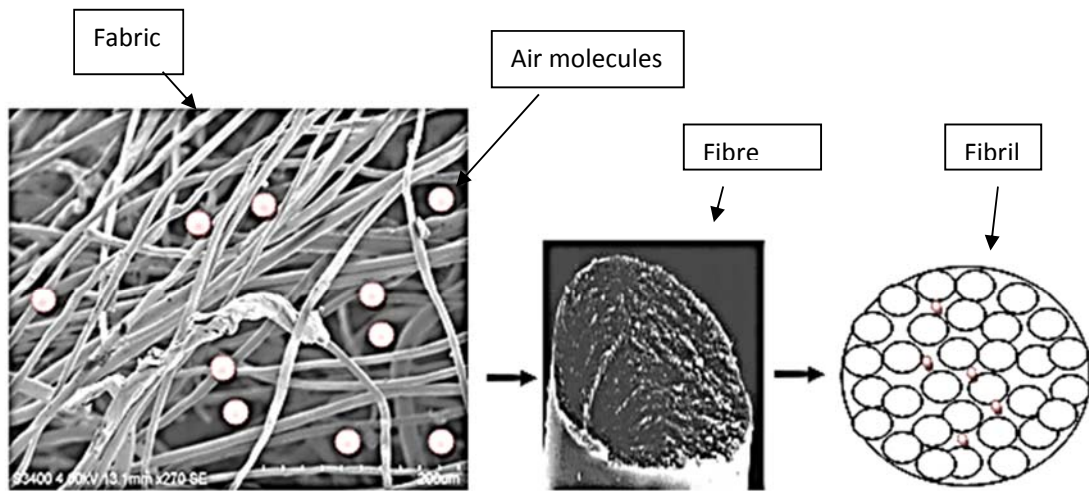
Thermal resistance is a measurement of a temperature difference by which an object or material resists a heat flow. The thermal resistance of the developed hydroentangled (S14) fabric was higher than the commercial nonwoven (E1) and woven fabrics (W1) both in the dry and wet conditions, as shown in Figure 4.87. This was mainly because of the fabric structure, as the developed fabric exhibited higher thickness (Table 4.19) and air is trapped between the pore of the fabric. Frydrych et al (85) have reported that the thermal resistance is proportional to the fabric thickness and the higher thermal resistance results in a decrease in the heat loss by the fabric. Snezana et al (152) have found that an increase in the fabric thickness means an increase in its porosity as other parameters were same, which increases the air

volume in the fabric interstices. Because of the trapped, air heat cannot be transmitted effectively through the fabric structure and hence the fabric exhibits higher value of thermal resistance.



**Figure 4.87** Thermal resistances of developed, commercial and woven fabrics in dry and wet state

According to Mazzuchetti et al (155) the thermal resistance of fabric is proportional to its bulk density, however, the results of our research show that converse is the case. According to Table 4.19 the bulk density of the commercial hydroentangled fabric (E1) is higher than that of the developed fabric (S14) but E1 showed the lower value of thermal resistance as compared to the developed hydroentangled fabric. Therefore, from our study, it appears that the thermal resistance is not proportional to the bulk density of the fabric but the nature of the fibre, the porosity and the fabric structure have a considerable influence on fabric's thermal resistance. A more porous structure in a thicker fabric will hold more air and this will increase the thermal resistance of the fabric. The results presented in Figure 4.87 show that the developed fabric has higher thermal resistance as compared to the commercial nonwoven and woven fabrics, both in the dry and wet conditions. Therefore, on the basis of these results it may be supposed that the developed fabric will be less comfortable to the wearer.



**Figure 4.88** Structure of developed hydroentangled fabric (S14)

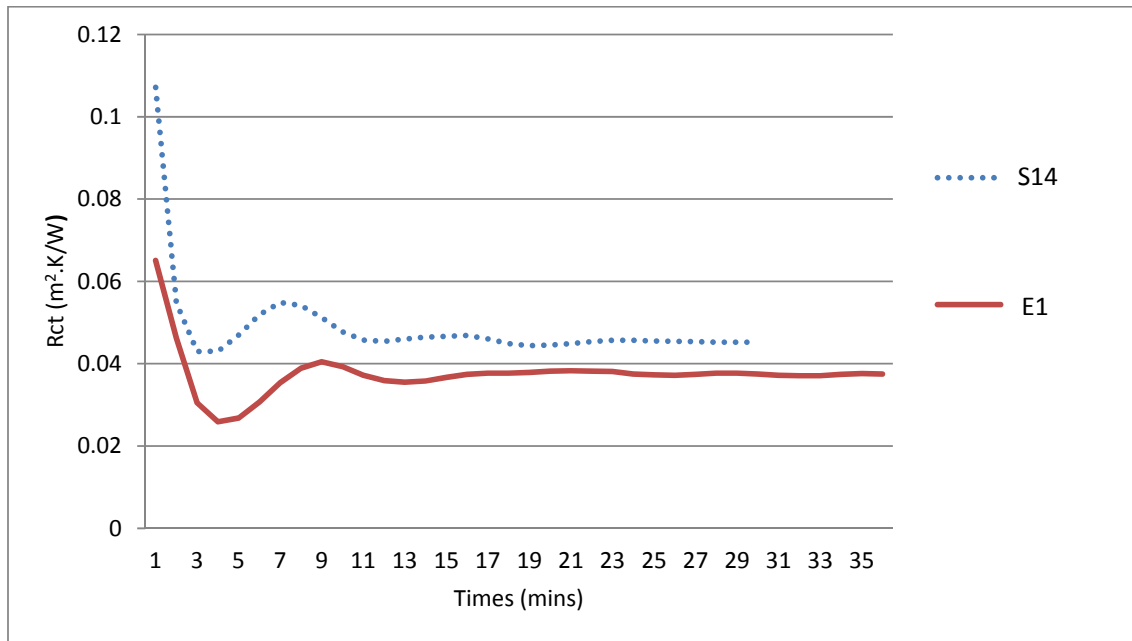
However, Figure 4.88 show highly porous nature of the developed fabric (S14), which results in the high air permeability of the fabric, thus leading to the forced convection heat transfer from the body to environment during any movement and this could keep the body at a comfortable level. Onofrei et al (156) have proposed that the still air in the fabric structure influences the heat conductivity of the fabric and fabric thickness also an effect on the thermal behaviour of the fabric. The fabric with the higher thickness exhibits the higher thermal resistance and this study also been confirmed by our findings. The developed fabric showed higher thermal resistance because of its higher thickness that was 0.86 mm, which is higher than the commercial nonwoven and woven fabrics with thickness values 0.43mm and 0.48mm, respectively.

Furthermore, the commercial and woven fabric exhibited lower thermal resistance because of their fibre contents and fabric structure. Commercial hydroentangled fabric consisted polyester and nylon in their structures and both fibres are synthetic and have higher crystalline region in fibres, which assisted in heat transfer from the body to the environment through conduction process. Secondly, the commercial fabric exhibited lower fabric thickness (0.43 mm), which is almost half that of the developed hydroentangled fabric, and therefore has less amount of trapped air in the fabric structure and lower thermal resistance.

Thermal resistance of the fabrics was also determined by SGHP method and the results obtained were similar to those achieved by the Alambeta method. Figure 4.89



demonstrates that developed hydroentangled fabrics exhibited higher thermal resistance than the commercial nonwoven fabric.



**Figure 4.89** Thermal resistances of developed and commercial hydroentangled fabrics by SGHP.

Thermal resistance in dry state of the developed hydroentangled fabric was also determined after the thermal bonding process. The results presented in Table 4.20 show that the thermal resistance of the fabric was reduced after the thermal bonding process. On the other hand the thermal absorptivity in dry state was increased by 9% after the thermal process. It was because of the less trapped air in the fabric structure that assisted in passing the heat from the body to the environment effectively. Kopitar et al (157) found that the calendaring process changes the structure and the properties of the calendared nonwoven fabric because of its compressed structure and has lower amount trapped air within the layers of the fabric.



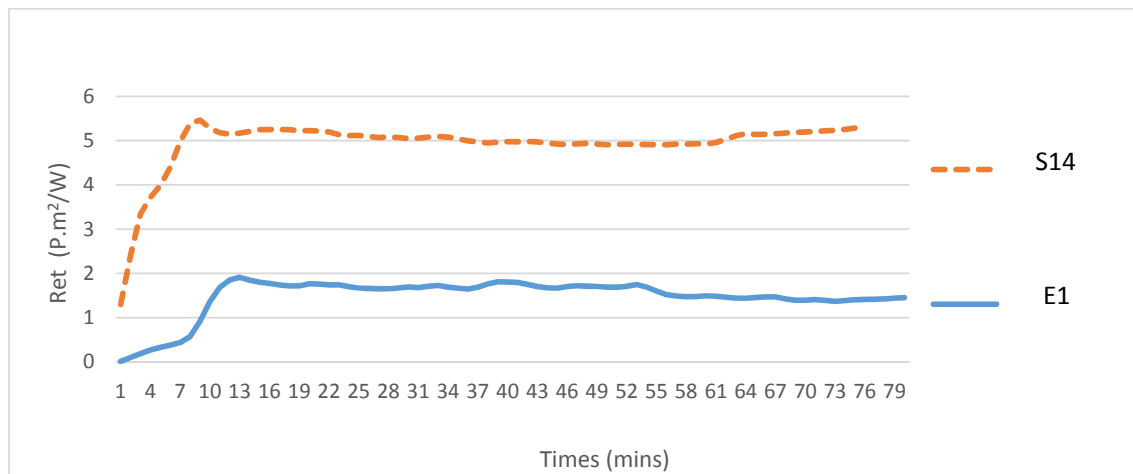
**Table 4.20** Thermal Absorption and Thermal Resistance of developed hydroentangled fabrics before and after thermal bonding process

S#	Fabrics	DRY		WET		% of loss in warmth to touch	% of recovery after 4 min wetting
		b ( $\text{w.m}^{-2}.\text{S}^{1/2}.\text{K}^{-1}$ )	r ( $\text{K.m}^2.\text{W}^{-1}$ )	b ( $\text{w.m}^{-2}.\text{S}^{1/2}.\text{K}^{-1}$ )	r ( $\text{K.m}^2.\text{W}^{-1}$ )		
1	S14	77	23.7	494	9.8	541%	44.58%
2	S16	84	23.3	312	13.8	271%	59.22%

#### 4.2.17.1. Water vapour resistance (Ret)

Moisture and heat transfer through fabric is measured in two states, steady state and transient state. The steady state gives data for the non-active condition and it is not able to explain the heat and moisture transfer in the actual wearing condition (158). It is known that the water vapour can be transferred from body to the environment through a fabric via different processes such as absorption-desorption and forced convection.

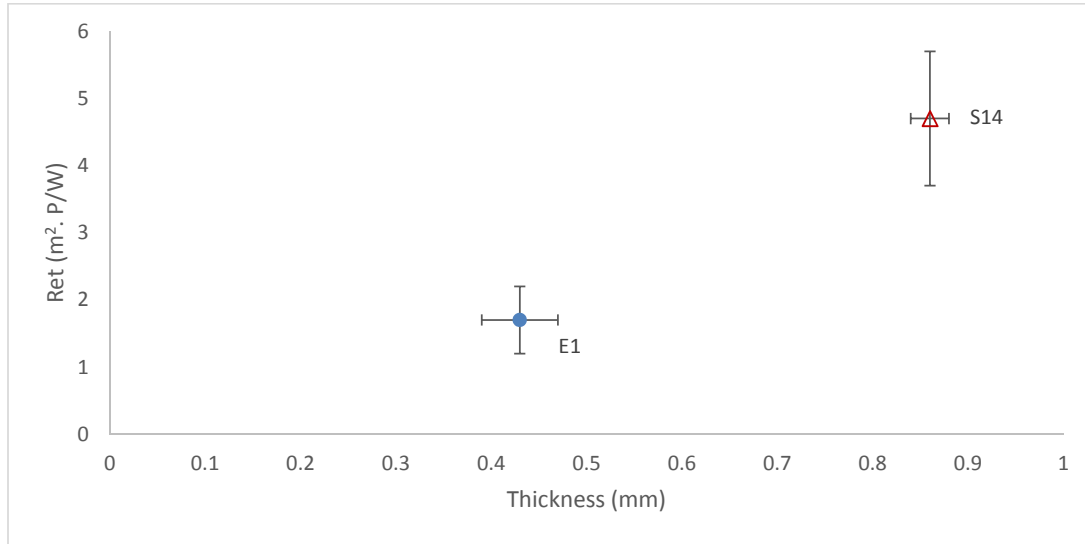
Figure 4.90 demonstrates that the developed hydroentangled S14 fabric exhibited higher water vapour resistance than the commercial hydroentangled E1 fabric. As it has been noted above that this test was conducted in steady state method. According to this test the developed fabric should give a warm feeling, however, because of the forced convection method of transporting water vapour from the skin to the environment it gives a cooling effect. Das et al (158) have also found similar results and explained that the forced convection plays a significant part in transferring the moisture from the skin to the atmosphere through the fabric, especially in a porous fabric structure. The fresh air entering the fabric and pushes the trapped air outward, which pushes the moisture to the atmosphere through forced convection and the body feel cool and comfort during working conditions.



**Figure 4.90** Water vapour resistances of developed and commercial hydroentangled fabrics by SGHP method

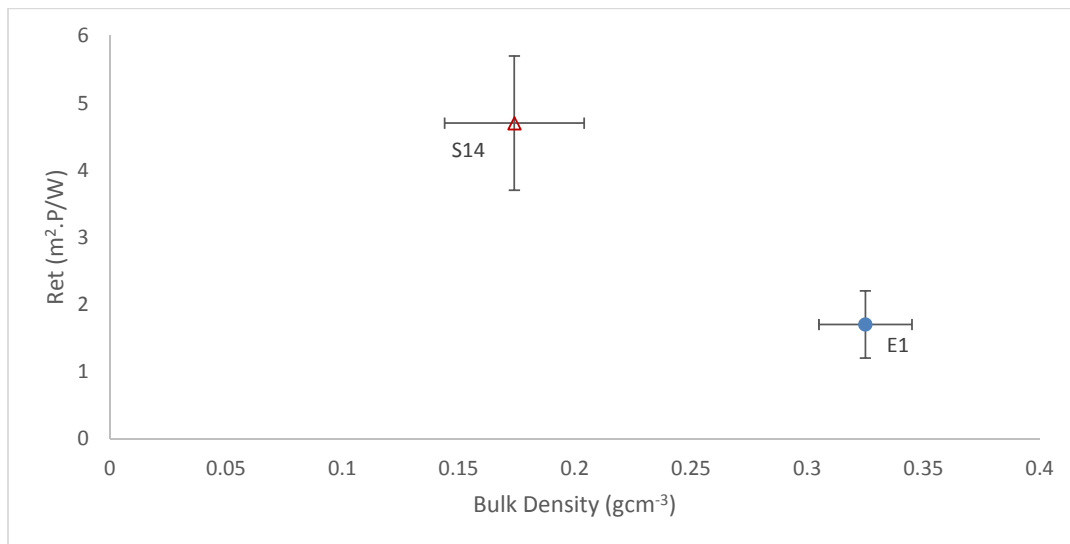
The higher value of water vapour resistance of the developed hydroentangled fabric was because of the nature of the fibres used and the structural. Firstly, the developed hydroentangled S14 fabric is comprised of 70% Tencel fibres, which are more absorbent and as results during the working conditions the sweat or moisture from the skin is absorbed by the Tencel fibres and is not quickly transferred to the atmosphere. Secondly, because of the fabric's porous structure the air is trapped in the pores or layers within the fabric structure. However, the commercial hydroentangled E1 fabric is comprised of synthetic polyester and nylon filament fibres, which do not absorb the moisture within their structures, therefore the moisture is dispersed to the atmosphere. Furthermore, because of the higher bulk density of the fabric more fibres are in contact with the skin, which also helps to transfer moisture to the atmosphere. Finally, the commercial fabric has a compressed structure and there are no or limited amount of trapped air in the fabric structure. For these reasons, the commercial hydroentangled fabric showed lower value of water vapour resistance, as shown in Figure 4.90.

Hajiani et al (159) found that the water vapour permeability (WVP) of a thinner fabric is higher than the thicker fabric and this finding is confirmed by the results presented in Figure 4.91, which show that the commercial hydroentangled fabric exhibited lower water vapour resistance because of its lower thickness than the developed hydroentangled fabric. The developed hydroentangled fabric showed the highest water vapour resistance because of its highest thickness value.



**Figure 4.91** Effects of fabric thicknesses on the water vapour resistance

Figure 4.92 illustrates the effect of fabric bulk density on its water vapour resistance. The results show that the developed S14 fabric, with the lower bulk density, has the higher water vapour resistance as compared to the commercial nonwoven E1 fabric. The commercial hydroentangled E1 fabric has a compressed structure, which reduces the amount of trapped air in the fabric, which assists in lowering its water vapour resistance for the reasons discussed earlier.



**Figure 4.92** Effects of fabric bulk density on the water vapour resistance

### **4.3 Garment development from developed hydroentangled fabric**

In order to show the potential of the developed nonwoven S14 fabric (Figure 4.93), the fabric was dyed and a garment was produced. Firstly, the fabric was dyed through the direct dyeing method.

Reactive dyes were used by using batch dyeing method. The details of the dyeing are given below:

Fabric weight: 177 g

Dye (30% of Wt.): 54 ml

Salt (30% of Wt.): 54 g

Dyeing: Batch method

Temp. 70°C

Time: Machine run for 45 min at 70°C

It was observed that the fabric maintained its integrity during and after the dyeing process. The fabric skewness was checked by using the ISO 13015:2013 test method and it was found that after the washing and dyeing the fabric was not skewed and only 2% shrinkage observed.

After dyeing, the fabric was cut and it was observed that during the cutting process the fabric behaved like a normal woven fabric. Then the fabric was subjected to the stitching process and two main machines were involved in stitching of the garment. The first one was lock stitch machine and the second was overlock machine. It was noted that during the stitching process there were no needle marks on the fabric and because of the fabric flexibility the stitching operation was smooth and easy to perform.




**Figure 4.93** Dyed shirt produced from the developed nonwoven S14 fabric showing types of stitches

It was believed until the recent past that nonwoven fabrics are not suitable for apparel applications as they lacked the functionalities required for garment manufacture. However, in view of the development of new materials and nonwoven processes it is now quite plausible to think that nonwovens will play an increasingly important role in the apparel sector. There are already commercial nonwoven fabrics available that may be used in specialised apparel applications, however, with further improvements, nonwoven fabrics will be available that are durable, flexible, soft and comfortable. Furthermore, the future nonwovens could also have the dimensionally stability and launderability, which is comparable to the conventional woven fabrics.

#### **4.4 Summary**

After details studies of the aesthetical and mechanical tests of developed hydroentangled fabrics and comparison with commercial hydroentangled nonwoven and reference woven fabric, the following points are summarised.

1. The hydroentangled S14 fabric studied had higher tensile properties compared to other commercial nonwoven hydroentangled fabric and it also showed higher tensile strength in the MD compared to woven fabric and very similar strength value in the CD.
2. Developed hydroentangled S14 fabric showed higher air permeability values as compared to the commercial nonwoven fabric and very similar to the woven fabric.
3. The hydroentanglement process decreased the web weight per unit area, which influenced the bending rigidity but enhanced the tensile properties of the developed hydroentangled fabrics.
4. Hydroentangled process is energy based process that transfer energy into fibres entangling process through water. Specific energy depends on the water pressure and the number of passes of the web.
5. Increase or decrease water pressure influenced on the mechanical properties of the hydroentangled fabrics such as tensile properties were increased when the water pressure was increased, the tearing strength of the developed hydroentangled fabric were also increased with the increasing water pressure, thus the highest tearing strength was achieved at 125 bars hydro pressure.
6. Needlepunching process reduced the weight per unit area of the fabric and showed needle marks after the hydroentanglement process.
7. Needlepunched hydroentangled nonwoven fabric exhibited lower tensile properties compared to the non-needlepunched hydroentangled fabrics.
8. Needlepunched hydroentangled fabrics exhibited lower bending rigidity values but the tensile strength of the fabric was low.
9. Developed hydroentangled fabrics showed lower bending rigidities compared to the commercial hydroentangled nonwoven fabric in the machine and cross machine directions.

10. Developed hydroentangled fabrics exhibited higher tearing strength in the machine and cross machine directions compared to the reference fabric commercial hydroentangled nonwoven fabric.
11. A uniformed surface structure was obtained by using Tencel and bicomponent, (sheath/core, PE/PET) through the hydroentanglement process.
12. After printing with a unique style like honeycomb, hydroentangled fabrics showed isotropic behaviour that is very suitable for apparel applications.
13. Developed hydroentangled fabric showed higher moisture management in term of wicking and absorbency values compared to the woven and the commercial hydroentangled fabrics, both in the MD and the CD.
14. Fabric produced at 100 or 125 bars hydro pressure gave homogenous fabric structure that assisted in enhancing the fabric quality.
15. Pre-needling before hydroentanglement process assisted in consolidation of the web that assisted in developing homogenous fabric structure.
16. Developed hydroentangled fabrics comprised of 70% cellulose based manmade Tencel fibre that gives comfort feeling to skin because of its very plain surface.
17. Using two passes of web, one each side  on hydroentangle machine for getting better entangling between the fibres.
18. At higher water pressure 125 bars hydro pressure the twisting behaviour of the fibres was enhanced because of the reverse action of the water after hitting the belt base.
19. Thermal bonding process enhanced the tensile strength of the developed hydroentangled fabric produced at 125 bars hydro pressure in the MD and CD, but reduced its breaking extension.
20. Calendaring process hypothetically should increase the tensile strength but in in this study it was found that after calendaring the tensile strength of the hydroentangled fabric produced at 125 bars hydro pressure was reduced.
21. It can be concluded from this study that it is possible to prepare hydroentangled nonwoven fabrics that have acceptable combination of mechanical and aesthetical properties, which are comparable with the woven fabrics and thus can be used in appropriate apparel applications.

## CHAPTER 5

### Summary and Recommendations for Future Work

#### 5.1 Summary

The purpose of this study was to investigate the limitations in the current nonwoven fabrics used for the apparel applications and to realise the functional properties of the fabrics that are suitable for apparel applications. After evaluating the current limitations in the available nonwoven fabrics and the properties required for apparel purposes, a production model was developed based on the selection of materials, manufacturing processes and testing procedures. After completion of this research, a very unique and innovative hydroentangled nonwoven S14 fabric was developed that has good characteristics for apparel applications in term of the outer garments for single and multi uses.

Chapter 1 is comprised of the introduction to nonwoven apparel. In this chapter, the conventional methods of preparing woven or knitted fabrics for apparel applications are briefly discussed. A review of nonwoven fabrics and their production methods is also presented and some limitations were found in terms of their aesthetic and technical properties such as softness, durability and drapability. This chapter highlights the fact that nonwoven production methods are cost-effective for making fabrics, therefore many companies are trying to explore these non-conventional methods to produce fabrics for apparel applications. The review showed that a great deal of research has been conducted to produce apparel type nonwoven fabrics and attempts have been made to commercialise some of the fabrics for garment making applications.

Chapter 2 deals with a comprehensive literature review of the previous work carried out on the development of nonwoven fabrics for apparel applications. The review also explores the commercialisation of the apparel type nonwovens since 1960 and the reasons for their market failure have been emphasised. Historically, nonwovens have been considered as disposable clothing because of their harsh and poor aesthetical properties. In this regard, many companies such as PGI, DuPont and Freudenberg have spent a great deal of time and resources to develop and commercialise nonwovens as replacements for woven fabrics and some of



these have met with a reasonable success. For example, Freudenberg have developed “Evolon” and DuPont have developed “Miratech” nonwoven fabrics that can be used as outer fabrics for garment production. The literature review resulted in outlining the research work required for the development of nonwoven fabrics for apparel applications, as it highlighted the main shortcomings of the currently available commercial nonwoven fabrics in terms of their applications in the apparel sector. It was found that the mechanical and aesthetical characteristics of the commercial nonwovens were not adequate for them to be suitable as replacements for woven fabrics.

The basic purpose of the literature review was to identify the main barriers for the introduction of nonwoven fabrics to apparel market. For example, Tyvek nonwoven fabric is made from polyethylene fibres and bonded together by using heat and pressure. This fabric has its limitations in apparel applications because the fabric has poor air permeability and moisture management characteristics as compared to the woven fabric.

Chapter 3 is comprised of the details about the experimental methods for the development and testing of the experimental nonwoven fabrics. This chapter is divided into different sections, which include the selection of the raw materials, web formation, hydroentanglement process, and finishing processes. A detailed discussion of the kind of material used and the reason for its selection is given. Different types of fabrics were prepared at different hydro pressures. The produced fabrics were investigated by using microscopic methods and structural differences were found between the fabrics produced at different hydro pressures. The testing standards and methods employed for the determination of tensile properties, moisture management, air permeability, tearing strength, thermophysiological characteristics, bending rigidity and fabric micro structure have been described.

Two types of production processes were used in this study for the preparation of nonwoven fabrics:

1. Intensive needlepunching and hydroentanglement
2. Light needlepunching and hydroentanglement

### **5.1.1 Dimensional properties**

Investigation of the effect of different hydro pressures on the structural properties of the nonwoven obtained was undertaken. Four fabrics were prepared at different hydro pressures (50, 75 100 and 125 bars) through the hybrid needlepunching-hydroentanglement process. Further two types of fabrics were prepared at 100 and 125 bars pressures through the direct hydroentanglement process. The fabric produces using the hybrid process exhibited lower thickness values than the fabrics produced through direct hydroentanglement process. It was established that increasing the hydro pressure resulted in a decrease in the thickness values of the fabric. It was also observed that with the increasing hydro pressure the density of the fabric was also increased, which had a significant effect on the mechanical and aesthetical properties of the fabrics, both in the machine and cross direction.

### **5.1.2 Bending rigidity**

Bending rigidity (BR) values of all the developed fabrics were determined by using BS 3356:1990 testing standard. These results were compared with the reference nonwoven and woven fabrics. It was found the bending rigidity of the developed nonwoven fabrics was better than the commercial hydroentangled nonwoven fabric and the values were very similar to that of the woven fabric in the machine and cross directions. The results also show that the hydro pressure has a direct effect on the bending rigidity of the developed hydroentangled fabrics in the machine and cross directions due the changes in the fabric structure. The hydroentangled nonwoven fabric produced through the hybrid process exhibited lower values of the bending rigidity than the fabric produced through direct hydroentanglement process.

In comparison with the reference woven and commercial hydroentangled fabrics, it was found that the fabric produced at 75 bars and 100 bars hydro pressure, through the hybrid process, exhibited BR values that were very close to the BR values obtained for woven fabric in the MD. On the other hand, all developed nonwoven hydroentangled fabrics showed better bending rigidity then the commercial hydroentangled nonwoven fabric in the MD.

It was also found that after calendering process the bending rigidity was increased in all developed hydroentangled nonwoven fabric because of structural changes that occurred during the calendaring process. There was a good correlation between the

bending rigidity and the thickness values of the fabric and it was found that with increasing thickness the bending rigidity of the fabric was increased.

### **5.1.3 Moisture management**

Moisture transport in the fabric determines the comfortability of the fabric. It helps to maintain the body temperature at standard condition to provide comfort to the wearer. In chapter 4, it was established that moisture management mainly depends on the fabric structure. The developed hydroentangled nonwoven fabric produced at higher hydro pressure like 100 and 125 bars exhibited higher wicking and absorbency values than the woven and commercially available hydroentangled nonwoven fabric, both in the machine and cross machine directions. It was because of the usage of unique materials, 70% Tencel fine fibres having 0.9 dtex and 30% bicomponent, sheath/core, PE/PET fibres having 2.2 dtex. Tencel fibres exhibit significantly higher wet tenacity value (34-38 CN/tex) than the other cellulosic fibres such as cotton. Due to the microfibril structure, Tencel fibres possess high capillary capability, which enhances the moisture management of the developed hydroentangled nonwoven fabrics.

The fabric prepared through hydroentanglement process at 100 (S13) and 125 bars (S14) hydro pressures exhibited higher wicking values than the other developed hydroentangled, woven and commercial hydroentangled nonwoven fabrics, both in the machine and cross machine directions. It may be concluded that moisture management in nonwoven fabrics mainly depends on the fabric structure, fibre composition and the bonding techniques used.

It was also found that after the calendaring process the wicking and absorbency behaviour of the developed hydroentangled S18 fabrics were changed. After calendaring process, developed hydroentangled S18 fabric exhibited lower values of wicking and absorbency in the machine and cross machine directions. The main reason for lowering of absorbency of the fabric is the melting of the bicomponent fibres that created strong thermal bonding between the fibres that restricted the water movements in the fabric structure.

### **5.1.4 Tensile properties**

In general, the tensile properties of the developed hydroentangled nonwoven fabric increased with the increase in the hydro pressure, therefore, the fabrics produced at

100 and 125 bars hydro showed higher tensile strength than those produced at the lower hydro pressures (50 and 75 bar). At the higher hydro pressure, the fabric structure was compacted and had more fibres per unit area of the fabric, which resulted in the stronger interaction between the fibres due to the application of the water jet pressure. The fabrics S14 produced at 125 bars hydro pressure (pre-needling) very homogeneous and exhibited high tensile properties. The tensile strength of the nonwoven fabric showed good correlation with the hydro pressure. It may be concluded that the tensile strength of the fabric increased with the increase in the pressure of the hydroentanglement process.

It was also found that the breaking extension of the fabric showed a tendency to decrease as the hydro pressure was increased. This was because of restriction of the movement of the fibres within the fabric structure. It was established that there is negative correlation between the fabric extensibility and the hydro pressures in the MD of the fabric. A comparison with the reference fabrics showed that the fabric produced at 125 bars hydro pressure through the hydroentanglement process exhibited higher tensile strength and lower breaking extension in the MD. This fabric also showed better results in term of tensile properties in the CD. After the thermal bonding and the calendaring processes, the tensile strength of the fabrics S16 and S18 developed at 125 bar pressure was increased to some extent but the breaking extension was significantly reduced as compared to other the developed hydroentangled fabrics.

It can be concluded that the developed hydroentangled S14 fabric produced at 125 bars hydro pressure through the hydroentanglement process (pre-needling) exhibited much higher tensile properties than the other developed hydroentangled fabrics. The tensile strength of this S14 fabric was higher tensile than that of the commercial hydroentangled nonwoven fabric (E1) and similar to the woven fabric (W1) in the machine and cross directions. Therefore, the hydroentangled fabric produced at 125 bar pressure may be suitable for some apparel applications as the outer fabric.

#### **5.1.5 Air permeability**

The developed hydroentangled nonwoven S14 fabric produced at 125 bars hydro pressure showed higher air permeability values as compared to the other developed fabrics. It showed air permeability value of 448 mm/sec that is 85% higher than the

commercial hydroentangled nonwoven fabric (E1) and this value was very close to that of the woven fabric. Furthermore, after the treatment of the developed fabric through the thermal and calendaring processes, the air permeability values were decreased to 413 and 93 mm/sec, respectively. These air permeability values were still better than those obtained for the commercially available hydroentangled nonwoven fabric investigated in this study.

The changes in the air permeability of the fabric were much more pronounced as a result of the calendaring process. There were different factors that affected the air permeability of the nonwoven, which include the changes in the fabric density and the structure after the calendaring process. It was found that when the nonwoven fabric density was increased then the air permeability values were decreased, however, for the woven fabric density changes do not have any significant effect on its air permeability values.

The commercial hydroentangled E1 fabric evaluated in this study is prepared by using filaments of PA and PET (island in the sea), pie wedge bicomponent fibres, and because of their micro structure there are very limited spaces between the filaments to allow the air to pass through the fabric, which result in the lower values of air permeability obtained.

#### **5.1.6 Tearing property**

Developed hydroentangled nonwoven S14 fabric produced at 125 bars hydro pressure (pre-needling) exhibited higher tearing strength in the machine and cross machine direction as compared to the commercial hydroentangled nonwoven E1 fabric. It was because of its flexible fabric structure that resisted tearing forces. On the other the rigid and compact structure of the commercial hydroentangled nonwoven fabric caused lowering of its tearing strength.

When the developed nonwoven S14 fabric was subjected to the thermal bonding and calendaring processes, the tearing strength of the fabric was increased in the CD but reduced in MD. However, the CD tearing strength of the developed fabric was still higher than that of the commercial hydroentangled nonwoven fabric. Therefore, it may be concluded that the fabric flexibility or fibre movement within the structure of the fabric play vital roles in determining the tearing strength of the fabric.

### **5.1.7 Thermophysiological property**

Thermal comfort properties of a fabric are the basic requirements for the wearer. One of the basic functions of the fabric is to maintain the body temperature against external elements or weather conditions. In this research, three basic tests were carried out and evaluated according to the standards. These tests were thermal absorption, thermal resistance and water vapour resistance.


Thermal absorption test concluded that the developed hydroentangled S14 fabric gave lower value of thermal absorption in the dry state and this will provide warm feeling to the wearer and wearer would feel uncomfortable. This is because of fabric structure, since the developed fabric showed higher thickness than the commercial nonwoven and woven fabrics. Secondly, because of the porous structure of the developed fabric, the trapped air was present in the fabric layers. That trapped air resisted transfer of the heat from the body to the atmosphere due to which the developed gave a warmer feeling to the wearer. However, this test was carried out in steady static state, but in the normal use due to the body motion fresh air will hit the body and air will pass through the fabric replacing the static warm air from the fabric structure to the environment. Because of this forced convection the wearer will feel cool and comfortable.

Water vapour resistance test was carried out by SGHP method and it was found that developed hydroentangled fabric showed higher water vapour resistance than the commercial hydroentangled fabric and it was because of fibres and fabric structure. 70% Tencel fibres were used to develop the hydroentangled fabric. Tencel is more absorbent fibre and during sweating it absorbs the body moisture, which is held within its structure and is not transferred to the environment.

### **5.2 General conclusion**

22. The hydroentangled S14 fabric studied had higher tensile properties compared to other commercial nonwoven hydroentangled fabric and it also showed higher tensile strength in the MD compared to woven fabric and very similar strength value in the CD.
23. Developed hydroentangled S14 fabric showed higher air permeability values as compared to the commercial nonwoven fabric and very similar to the woven fabric.

24. The hydroentanglement process tends to decrease the web weight per unit area, which influenced the bending rigidity but enhanced the tensile properties of the developed hydroentangled fabrics.
25. Hydroentangled process is energy based process that transfer energy into fibres entangling process through water. Specific energy depends on the water pressure and the number of passes of the web.
26. Increase or decrease water pressure influenced on the mechanical properties of the hydroentangled fabrics such as tensile properties were increased when the water pressure was increased, the tearing strength of the developed hydroentangled fabric were also increased with the increasing water pressure, thus the highest tearing strength was achieved at 125 bars hydro pressure.
27. Needlepunching process reduced the weight per unit area of the fabric and showed needle marks after the hydroentanglement process.
28. Needlepunched hydroentangled nonwoven fabric exhibited lower tensile properties compared to the non-needlepunched hydroentangled fabrics.
29. Needlepunched hydroentangled fabrics exhibited lower bending rigidity values but the tensile strength of the fabric was low.
30. Developed hydroentangled fabrics showed lower bending rigidities compared to the commercial hydroentangled nonwoven fabric in the machine and cross machine directions.
31. Developed hydroentangled fabrics exhibited higher tearing strength in the machine and cross machine directions compared to the reference fabric commercial hydroentangled nonwoven fabric.
32. A uniformed surface structure was obtained by using Tencel and bicomponent, (sheath/core, PE/PET) through the hydroentanglement process.
33. After printing with a unique style like honeycomb, hydroentangled fabrics showed isotropic behaviour that is very suitable for apparel applications.
34. Developed hydroentangled fabric showed higher moisture management in term of wicking and absorbency values compared to the woven and the commercial hydroentangled fabrics, both in the MD and the CD.
35. Fabric produced at 100 or 125 bars hydro pressure gave homogenous fabric structure that assisted in enhancing the fabric quality.

36. Pre-needling before hydroentanglement process assisted in consolidation of the web that assisted in developing homogenous fabric structure.
37. Developed hydroentangled fabrics comprised 70% cellulose based manmade Tencel fibre that gives comfort feeling to skin because of its very plain surface.
38. Using two passes of web, one each side  on hydroentangle machine for getting better entangling between the fibres.
39. At higher water pressure 125 bars hydro pressure the twisting behaviour of the fibres was enhanced because of the reverse action of the water after hitting the belt base.
40. Thermal bonding process enhanced the tensile strength of the developed hydroentangled fabric produced at 125 bars hydro pressure in the MD and CD, but reduced its breaking extension.
41. Calendaring process hypothetically should increase the tensile strength but in in this study it was found that after calendaring the tensile strength of the hydroentangled fabric produced at 125 bars hydro pressure was reduced.
42. It can be concluded from this study that it is possible to prepare hydroentangled nonwoven fabrics that have acceptable combination of mechanical and aesthetical properties, which are comparable with the woven fabrics and thus can be used in appropriate apparel applications.

### 5.3 Recommendations for future work

Further systematic studies are required to investigate the hydroentangled fabrics produced by using Tencel and bicomponent sheath/core PE/PET fibres via the hydroentanglement process. The optimisation of the bonding processes and other fabric finishing technique can further improve both the mechanical and aesthetical properties of the developed nonwoven fabrics and enhanced their suitability for apparel applications. It has been observed in this research that the developed hydroentangled fabrics possessed mechanical and aesthetical properties that are better than the commercially available nonwoven fabric and similar to the woven fabrics. However, further optimisation of the intra fibre bonding will make these fabric to withstand the external forces during the washing processes and make the nonwoven fabrics launderable.



The mechanical and aesthetical properties of the hydroentangled nonwoven fabrics can be further enhanced by:

1. Minimisation of the variation in the fabric structure through the formation of more uniform webs. This can be achieved by employing better fibre blending and feeding techniques to the carding machine.
2. Optimisation of both the needlepunching and hydroentanglement processes. The needlepunching process may enhance the surface smoothness and strength of the fabric by optimisation of the process parameters, for example the use of finer needles and control of fibre dispersion during the needling process.
3. It appears that 100 - 125 bars hydro pressure is the most suitable for making the hydroentangled fabrics for apparel applications, therefore, more studies should be carried on the production of nonwoven fabrics in this range.
4. Further studies are also required to investigate the dimension stability of the hydroentangled fabric during washing.
5. The nonwoven fabric developed show good sewing behaviour, however, improvements to this aspect of the fabric could also be made by optimisation of the fabric structure.
6. The best nonwoven S14 fabric developed in this study shows good and interesting dyeing and printing characteristics. It may be possible to enhance fabric stability of the hydroentangled fabric during working conditions by using appropriate printing techniques and patterns.
7. Use of softener spray on the hydroentangled nonwoven fabrics in order to improve the hand feel of the nonwoven fabrics developed.
8. Thermophysiological properties can be enhanced by decreasing the thickness of the fabrics and by optimisation of the bonding processes. A decrease in the thickness of the fabric would lower amount of trapped air in the fabric structure, which will reduce the thermal resistance of the fabric.
9. Other bicomponent core/sheath fibres, such as polyester/polyester, should be explored for thermal bonding, which could improve both the dyeability and thermal comfort of the nonwoven fabric obtained.

10. Non-fibrillating version of the Tencel fibre could also be used, which will allow the use of higher hydro pressure without causing any fibrillation and hence migration of the fine fibres to the surface of the fabric, which gives the fabric poor appearance and uneven dye uptake.

## References

1. <http://www.smitherspira.com/news/2013/november/significant-growth-predicted-for-global-nonwovens>, accessed on 1 Oct. 2014.
2. M. Newbery, Tomorrow's apparel industry: Products, markets, sourcing and processes-forecasts to 2017, pp. 29-30, Sep 2011.
3. B. Orzanda, Blank Canvas: Elastomeric Nonwoven as Fashion Apparel, INTC06, Houston, TX, Sep. 25-27, 2006.
4. S. Anand, k. Betra, B. Pourdeyhimi, Introduction to Nonwoven Technology, Textile World, Vol. 162, pp. 29-33, June 2012.
5. R. Jurg, Versatile Nonwoven for Fashionable Fabrics, Textile World, Vol. 159, No.5, pp.20, Sep. 2009.
6. Next Generation nonwoven fabrics: Development for Outerwear, JTN Monthly Asian Textile Business, Vol. 564, pp. 16-18, Nov. 2001.
7. F. Turbak, T. L. Vigo, A New System for Classifying Textiles, Nonwovens An Advanced Tutorial, TAPPI Publishing Ltd, pp.1-2, 1989.
8. R. Horrocks, S. C. Anand, Handbook of Technical Textiles, Woodhead Publishing Series in Textiles, Volume 1, second edition, pp. 164-165,2016.
9. [www.inda.org](http://www.inda.org), Accessed on 12 Dec. 2012.
10. <http://www.glamoursplash.com/2008/11/disposable-paper-dresses-of-1967.html>, Accessed on Dec. 2012.
11. [http://nonwovensindia.com/historic\\_background.html](http://nonwovensindia.com/historic_background.html), Accessed on Jan. 2013.
12. <http://www.edana.org/discover-nonwovens/facts-and-figures>, Accessed on March 2015.
13. H.J. Lee, N. Cassill, Analysis of World Nonwoven Market, Journal of Textile and Apparel, Technology and Management, Vol. 5, No. 3,pp. 10-18, 2006.
14. A.D. Hewitt, Coloration of Hydroentangled Nonwoven fabrics, PhD Thesis, University of Leeds, pp. 30, 2008.
15. <https://store.extension.iastate.edu/Product/pm1663d-pdf>, Accessed on June. 2013.
16. [www.paperdressvintage.co.uk/invintage-boutique/history](http://www.paperdressvintage.co.uk/invintage-boutique/history), Accessed on 12/10/2013.
17. [www.ultrasuede.com/about/science.html](http://www.ultrasuede.com/about/science.html), Accessed on 14/10/2013.

18. S. E. Shawver, L. W. Collier, P. W. Estey, S. C. Paul, Elastic Breathable Barrier Fabric, US Patent 5,695,849, Dec. 1997.
19. S.R. Bornslaeger, Nonwoven Laminate For Recreation Fabric, US Patent 4,374,888, Feb. 1983.
20. E. Fahrbach, A. Graber, J. Knoke, H. Schweizer, B. Tecl, Nonwoven Fabric Having The appearance Of A Woven Fabric, US Patent, 4,259,390, Mar. 1981.
21. L.A. Connor, P. Maddern, Garment Of A Durable Nonwoven Fabric, US Patent 5,798,167, Aug. 1998.
22. N. Hatta, Y. Araida, M. Tadokoro, Composite Nonwoven Fabric for Protective Clothing and Production Method Thereof, U.S. Patent 7,022,635 B2, 4 April 2006.
23. D. N. Welchel, A. E. Wright, M. L. DeLucia, Breathable Composite Barrier Fabric and Protective Garments Made Thereof, U.S. Patent 6,286,145 B1, 11 Sep. 2001.
24. V. Narayanan; G. Arinder; S. Szezesuil, Durable and Fire Resistant Nonwoven Composite Fabric Based Military Combat Uniform Garment, U.S. Patent 7,659,217 B2, 2 Oct. 2008.
25. [www2.dupont.com](http://www2.dupont.com), Accessed on 05/09/2014.
26. [http://store.americanapparel.net/tyvek-day-jacket\\_rsaj402](http://store.americanapparel.net/tyvek-day-jacket_rsaj402), Accessed on 10/09/2014.
27. Kim Anderson, Nonwoven Fabric in Fashion Apparel, Available on [www.techexchange.com](http://www.techexchange.com), accessed on 10/10/2014.
28. <http://www.nonwovensnetwork.com/fashion/>, Accessed on 08/11/2014.
29. [www.evolon.com](http://www.evolon.com), Accessed on 10/11/2014.
30. <http://www.pgi-industrial-europe.com/en/apex-fabrics>, Accessed on 10/11/2014.
31. O.B. Berkalp; B. Pourdeyhimi; A. Seyam; R. Holmes, Texture Retention after Fabric-to-Fabric Abrasion, Textile Research Journal, vol.73, pp. 316-321, April 2003.
32. E. Gross, Lycra Launches Mill Network: Nova Nonwovens, Textile World, vol.150, No. 8, pp. 26, Aug. 2000.
33. Nonwoven Launch Opens the Door for New Wool Products, [www.wool.com](http://www.wool.com), media release on 17 July 2003.

34. <https://www.wool.com/about-awi/media-releases/non-woven-launch-opens-the-door-for-new-wool-products/?category=0&year=2003&month=0&page=13>, Accessed on 15/11/2014.
35. I. Holme, Broader perspective offered on future of performance nonwoven, *Technical Textile International*, vol. 15, No. 6, pp. 21-26. Sep. 2006.
36. V. Narayanan, Gary Arinder, Stephen Szczesuil, US Patent 7659217 B2, 6 June 2008.
37. J. McCann, D. Bryson, *Smart Clothes and Wearable Technology*, Woodhead Publishing Ltd, Cambridge, pp.176-177, 2009.
38. V. Parthasarathi, G. Thilagavathi, Developing antiviral surgical gown using nonwoven fabrics for health care sector, *Afr Health Sci.*, vol.13, issue 2, pp. 327-332, June 2013.
39. [Global.lakeland.com/ar/documents/chemical.pdf](http://Global.lakeland.com/ar/documents/chemical.pdf), Accessed on 09/09/2016.
40. N. Hatta, Y. Araida, M. Tadokoro, Composite Nonwoven Fabric for Protective Clothing and Production Method Thereof, U.S. Patent 7,022,635 B2, 4 April 2006.
41. L. Wadsworth, H. Suh, H. C. Allen, Cotton-surfaced Nonwoven for Short-Wear-Cycle Apparel, *International Nonwoven Journal*, vol.9, No. 2, 2000.
42. S. Backer, D.R. Petterson, Some Principles of nonwoven Fabrics, *Textile Research journal*, Vol.30, no.9,pp. 704-711, Sep. 1960.
43. R. Postle, Fabric Objective Measurement Technology, *IJCST*, vol.2, No. 3/4, 1990.
44. J. Gersak, Development of the system for qualitative prediction of garments appearance quality, *IJCS*, Vol. 14, No3/4,pp. 169-180, 2002.
45. R. L. Barker, From fabric hand to thermal comfort: the evolving role of objective measurement in explaining human comfort response to textile, *IJCS*, Vol. 14, No. 3/4.,pp. 181-199, 2002.
46. G. Supuren, N. Oglakcioglu, N. Ozdil, A. Marmarali, Moisture management and thermal absorptivity properties of double-face knitted fabrics, *TRJ*, vol.81, No. 13, pp. 1320-1330, July 2011.
47. M. Yanilmaz, F. Kalaoglu, Investigation of wicking, wetting and drying properties of acrylic knitted fabrics, *Textile Research Journal*, vol. 82, No. 8,pp. 820-83, 2012.
48. O. Troynikov, W. Wardiningsih, Moisture management properties of wool polyester and wool bamboo knitted fabrics for sportswear base layer, *textile Research Journal*, vol. 81, No. 6,pp. 621-631, 2011.

49. R. A. Chapman, Applications of nonwovens in technical textiles, woodhead publishing limited, Cambridge, pp. 125-126, 2010.
50. S.K. Batra, Fibres as Structural Elements in Nonwovens, 10th Technical Symposium of INDA, New York, Nov. 17-19, 1982.
51. W. Albrecht., Manmade fibres for the nonwoven industry-standard and special grades, properties and potential uses, INDEX 87, EDANA, 1987.
52. C. F. White., Hydroentanglement Technology Applied to Wet-formed and other Precursor Webs, Tappi Journal, pp. 187-192, June 1990.
53. G. K. Tyagi., S Bhattacharya., P Kumar., Hand-related properties of polyester-viscose and polyester-cotton ring and MJS yarn fabrics- Effects of fibre profile and finishing treatment, IJFTR, vol.33, pp. 126-131, June 2008.
54. Morton, Hearle, Physical Properties of Textile Fibres, John Wilky, New York, 1993.
55. F.J. Mederies, Hydroentanglement Methods & Products, The Proceedings of Inda-Tech, 1996.
56. A. Pourmohammadi, S.J. Russell, S. Hoffele, Effect of water jet pressure profile and initial web geometry on the physical properties of composite hydroentangled fabrics, Textile Research Journal, pp. 503-508, June 2003.
57. M. Ghane, R. Saghafi, M. Zarrbini, D. Semnani, Evaluation of Bending Modulus of Needle-Pinched Fabrics Using Two Simple Supported Beam Method, Fibres and Textile in Eastern Europe, vol 19, No. 4(87), pp 89-93, 2011.
58. Gilmore et al., Methods for foam bonding of spunlace fabric to produce enhanced fabric characteristics, North Carolina State University, U S Patents 6579391, 2003.
59. P. D. Dubrovski., P. F. Cebasek., Analysis of Mechanical Properties of Woven and Nonwoven Fabrics as an Integral Part of Compound Fabrics, FIBRES & TEXTILES in Eastern Europe, vol. 13, No. 3(51), pp 50-53, July 2005.
60. A. Das., R. J. Raghav., Study on bursting behaviour of spunbonding nonwoven fabric: Part II – Change in fabric characteristics due to repeated bursting cycle, Indian Journal of Fibre & Textile Research, vol.36, pp 53-57, March 2011.
61. A.M.Seyam., D.A.Shiffler, H.Zheng. An examination of hydroentangling process variables, International Nonwoven Journal, (01), pp 25-33, 2005.
62. N. Mao, S. J. Russell, Structure-Process-Property Relationships of Hydroentangled Fabrics, Lenzinger Berichte, vol, 84, pp 50-61, 2005.

- 63.P. Sawheny, H. Allen, M. Reynolds, R. Slopek, B. Condon, D. Hui, S. Wojkowski, Effect of web formation on properties of hydroentangled nonwoven fabrics, *World Journal of Engineering*, vol. 9(5), pp 407-416, 2012.
- 64.A. Bonnef, M. Goldwasser, Method for making a hydroentangled nonwoven fabric and the fabric made thereby, Patent, EP1382731 A1, Jan 2004.
- 65.Pourdeyhimi., Anantharamiah, Staple Fibre Durable Nonwoven Fabrics, U. S. Patent Publication 20090258559, October 15, 2009.
- 66.E. Ghassemieh, M. Acar, H. K. Versteeg, Microstructural analysis of nonwoven fabric using scanning electron microscopy and image processing. Part 2: application to hydroentangled fabric, *Materials: Design and Applications*, vol. 216, pp 211-218, 2002.
- 67.Q. Qiao, The Structure and Mechanical Properties of Hydroentangled Nonwoven Fabrics, PhD thesis, Dept. Of Textile Industries, University of Leeds, UK, 1997.
- 68.S. Salahel-Din Shoukry Saleh, Low Stress Mechanical Properties of Hydroentangled Fabrics, PhD thesis, School of Textile and Design, University of Leeds, UK, 2003.
- 69.M. S. Cheema, Application of Hydroentangled Fabrics in Sports Apparel, MSc Thesis, School of Design, University of Leeds, UK, 2010.
- 70.X. Hou, M. Acar, V. V. Silberschmidt, Tensile Behaviour of Low Density Thermally Bonded Nonwoven Material, *Journal of Engineered Fibres and Fabric*, vol 4(1), pp 26-33, 2009.
- 71.S. Michielsen, B. Pourdeyhimi, P. Desai, Review of Thermally Point-Bonded Nonwoven: Materials, Processes, and Properties, *Journal of Applied Polymer science*, vol. 99, pp. 2489-2496, 2006.
- 72.G. S. Bhat, R. Nanjundappa, Bond Structure and Tensile Properties of Thermal Bonded Polypropylene Nonwovens, *Textile and Light Industrial science and Technology*, Vol. 2, issue 2, pp. 49-53, April 2013.
- 73.G. S. Bhat, P. Gulgunje, K. Desai, Development of structure and properties during thermal calendering of polylactic acid (PLA) fibre webs, *Express Polymer Letters*, vol. 2, No. 1, pp. 49-56, 2008.
- 74.V. K. Midha, A. Mukhopadyay, Bulk and physical properties of needle-punched nonwoven fabrics, *Indian Journal of Fibre & Textile Research*, Vol. 30, pp. 218-229, June 2005.
- 75.M. G. Kamath, A. Dahiya, R. R. Hegde, Chemical Bonding, April 2004. Available on <http://www.engr.utk.edu/mse/Textiles/Chemical%20Bonding.htm>.

76. Gilmore et al, Methods for foam bonding of spunlaced fabric to produce enhanced fabric characteristics, North Carolina State University, U S Patent 6579391, 2003.
77. O. B. Berkalp, Air Permeability & Porosity in Spun-laced Fabric, *FIBRES & TEXTILE in Eastern Europe*, vol. 14, No. 3 (57), pp. 81-85, July 2006.
78. E. Cincik, E. Koc, An analysis on air permeability of polyester/viscose blended needle-punched nonwovens, *Textile Research Journal*, Vol. 82, No. 5, pp. 430-442, March 2012.
79. S. Debnath, M. Madhusoothanan, Thermal insulation, compression and air permeability of polyester needle-punched nonwoven, *Indian Journal of Fibre & Textile Research*, Vol. 35, pp. 38-44, March 2010.
80. N. Balasubramanian, A. K. Rakshit, A.N. desai, K. Venkatarayan, B. N. Bandyopadhyay, Avenues for produce development in nonwoven, *Proceedings, 29th Joint Technological Conference of ATIRA, BTRA, SITRA and NITRA*, (Bombay Textile Research Association, Mumbai 400086, India), 1988.
81. M. Tascan, E. A. Vaughn, Effects of Fibre Denier, Fibre Cross-Section Shape and fabric Density on Acoustical Behaviour of Vertically Lapped Nonwoven Fabrics, *Journal of engineered Fibres and Fabrics*, Vol. 3, Issue 2, pp. 32-38, 2008.
82. E. Karaca, N. Kahraman, S. Omeroglu, B. Becerir, effects of Fibre Cross Sectional Shape and weave Patteren on Thermal Comfort Properties of Polyester Woven Fabrics, *FIBRES & TEXTILE in Eastern Europe*, vol. 20, Issue 3(92), pp. 67-72, 2012.
83. J. Yekrang, B. Sarijeh, D. Semnani, M. Zarrebini, Prdiction of heat transfer and air permeability properties of light weight nonwoven using artificial intelligence, *Indian Journal of Fibre and Textile Research*, Vol. 40, pp. 373-379, 2015.
84. D. Bhattacharjee, V.K. Kothari, Measurement of thermal resistance of woven fabrics in natural and forced convection, *RJTA*, vol.12, No.2, pp. 39-49, 2008.
85. I. Frydrych, G. Dziworska, J. Biliska, Comparative Analysis of the thermal insulation properties of fabrics made of natural and man-made cellulose fibres, *Fibres & Textile in Eastern Europe*, pp. 40-44, 2002.
86. S. Alay, C. Alkan, F. Gode, Steady-state thermal comfort properties of fabrics incorporated with microencapsulated phase change materials, *Journal of the Textile Institute*, vol.103, No. 7, 2012.
87. Y. Li, *The science of clothing comfort*, Textile progress, vol. 1, No. 2, 2001.



88. P. Zhang, Y. Watanabe, S. H. Kim, H. Tokura, Thermoregulatory responses to different moisture-transfer rates of clothing materials during exercise, *J. Text. Inst.*, Vol. 92 (1), pp. 372-378, 2001.
89. R. Figueiro, A. Filgueiras, F. Soutinho, Xie Meidi, Wicking Behaviour and Drying Capability of Functional Knitted Fabrics, *Textile Research Journal*, March 2010.
90. C. Saricam, F. Kalaoglu, Investigation of Wicking and Dry Behaviour of Polyester Woven Fabrics, *FIBRE & TEXTILE in Eastern Europe*, Vol. 22, No. 3(105), pp. 73-78, 2014.
91. A. Perwuelz, P. Mondon, C. Caze, Experimental Study of Capillary Flows in Yarns, *Textile Research Journal*, vol. 70, pp. 333-339, 2000.
92. X. Chen, P. Vroman, M. Lewandowski, A. Perwuelz, Y. Zhang, Study of the Influence of Fibre Diameter and Fibre Blending on Liquid Absorption Inside Nonwoven Structure, *Textile Research Journal*, vol. 79 (15), Sep 16, 2009.
93. P. Sawhney, H. Allen, M. Reynolds, R. Slopek, B. Condon, D. Hui, S. Wojkowski, Effect of web formation on properties of hydroentangled nonwoven fabric, *World Journal of Engineering*, Vol. 9, No. 5, pp. 407-416, 2012.
94. [www.inda.org](http://www.inda.org), visited on 20/08/2015.
95. J.M. Keith, Dispersion of Synthetic Fibres in Wet-Lay Nonwovens, *Tappi Journal*, Vol. 77, No. 6, June 1994.
96. C. White, Hydroentanglement Technology Applied to Wet-formed and Other Precursor Webs, *Tappi Journal*, pp. 187-192, June 1990.
97. D.V. Parikh, R.R. Bresee, U. Muenstermann, A. Watzl, L. Crook, D. Gillespie, Spunlaced Cotton and Cotton Blend Cosmetic Pads and Bed Sheets: Study of Fiber Entanglement, *Journal of Engineered Fibers and Fabrics*, Vol.2, Issue 3, pp. 40-49, 2007.
98. V. K. Midha, A. Mukhopadyay, Bulk and physical properties of needle-punched nonwoven fabrics, *Indian Journal of Fibre & Textile Research*, Vol.30, pp. 218-229, June 2005.
99. Narayanan, Launderable and Durable Mechanically Bonded Nonwoven Fabric, US Patent 2011/0034100 AI, 10 Feb, 2011.
100. D.V. Parikh, R.R. Bresee, U. Muenstermann, A. Watzl, L. Crook, D. Gillespie, Basis weight uniformity of light needled hydroentangled cotton and cotton blend webs, *Journal of Engineered Fibers and Fabrics*, Vol.1, Issue 1, pp. 47-61, 2006.
101. H. Zheng, A. M. Seyam, D. Stiffler, The Impact of Input Energy On the Performance Of Hydroentangled Nonwoven Fabrics, *INJ*, Summer 2003.

102. A. Pourmohammadi, S.J. Russell, S. HOFFLE, Effect of water jet pressure profile and initial web geometry on the physical properties of composite hydroentangled fabrics, *Textile Research Journal*, vol.73, No. 6, pp. 503-508, June 2003.
103. N. Mao, S.J. Russell, A framework for determining the bonding intensity in hydroentangled nonwoven fabrics, *Composites Science and Technology*, No.66,pp. 80-91, 2006.
104. E. Ghassemieh, M. Acar, H.K. Versteeg, Improvement of the efficiency of energy transfer in the hydro-entanglement process, *Composites Science and Technology*, No. 61,pp. 1681-1694, 2001.
105. P. Xiang, A. V. Kuznetsov, A. M. Seyam, Modeling of the Hydroentanglement Process, *Journal of Engineered Fibers And Fabrics*, Volume. 1 Issue 2,pp. 1-15, 2006.
106. R. A. Ijaiya, Investigation and Analysis of Spunlaced Fabric Structure, MSc. Dissertation, University of Manchester, 1992.
107. D.Moyo, R.D. Anandjiwala, Asis Patnaik, Micromechanics of hydroentangled nonwoven fabrics, *textile Research Journal*, 2016.
108. S. Backer; D.R. Petterson, Some Principles of Nonwoven Fabrics, *Textile Research Journal*, Vol. 30,pp. 704-711, 1960.
109. N. Kesavaraja, T. Ramachandran, A study on Influencing Factors for Wetting and Wicking Behaviour, *Journal of The Institution of Engineers (India)* , vol. 84,pp. 39, 2004.
110. M.Tascan, A. Edward, Vaughn, Effect of fibre denier, fibre cross-sectional shape and fibre density on acoustical behaviour of vertically lapped nonwoven fabrics, *journal of engineered fibres and fabrics*, volume 3, issue 2,pp 32-33, 2008.
111. N. Mao, S.J.Russell, influence of fibre rigidity on the formation of hydroentangled structures, *Lenzinger Berichte*, Vol. 84, PP. 50-61,2005.
112. A. Slater, A. Wilkes, A. Versatile, High Performance Fibre for Nonwovens, *Lenzinger Berichte*, Vol. 82, pp 37-42, 2003.
113. [www.Tencel.com](http://www.Tencel.com), visited on 25 june 2014.
114. G K Taygi, Ashvani Goyal, R chattopadhyay, Influence of twist and blend ratio on characteristics of ring spun Tencel blended yarns, *Indian Journal of Fibre and Textile Research*, vol. 38,pp. 138-143, June 2013.

115. H. Firgo, K. C. Schuster, F. Suchomel, J. Manner, T. Burrow, M. Abu-Rous, The Functional Properties of Tencel®- A current Update, Lenzinger Berichte, Vol. 85, pp. 22-30, 2006.
116. D.J. Cole, Courtaulds Tencel Fibre in Apparel Fabrics, Lenzinger Berichte, Vol. 9, pp 45-47, 1994.
117. [www.fibervisions.com](http://www.fibervisions.com), visited on 27 June 2014.
118. E. Ghassemieh, M. Acar, H.K. Versteeg, Improvement of the efficiency of energy transfer in the hydro-entanglement process, Composite Science and Technology, vol. 61, pp. 1681-1694, 2001.
119. H. Zheng, M. Abdelfattah, D. Shiffler, The Impact of Input Energy on the Performance of Hydroentangled Nonwoven Fabrics, Nonwoven Cooperative Research Centre, College of Textile, NC State University, Raleigh, NC, US, 2003.
120. N Anantharamaiah., S Verenich., Behnam Pourdeyhimi, Durable Nonwoven Fabric via Fracturing Bicomponent Island-in-the-sea Filaments, Journal of Engineered Fibers and Fabrics, vol 3, issue 3, 2008.
121. B. P. Saville, Physical Testing of Textiles, Woodhead Publishing, London, 1<sup>st</sup> edition, pp. 209-211, 256-257, 1999.
122. S. Debnath, M. Madhusoothanan, Thermal resistance and air permeability of jute-polypropylene blended needle punched nonwoven, Indian Journal of Fibre & Textile Research, vol. 36, pp. 122-131, June 2001.
123. Y. Termonia, Lattice Model for the Drape and Bending Properties of Nonwoven Fabrics, Textile Research Journal, vol. 73, pp. 74-78, 2003.
124. M. Ghane, R. Saghafi, M. Zarrebini, D. Semnani, Evaluation of Bending Modulus of Needle-Punched Fabrics Using Two Simple Beam Method, Fibres & Textiles in Eastern Europe, Vol.19, No. 4, pp. 83-93, 2011.
125. S. Maity, Characteristics and Effect of Fibre Crimp in Nonwoven structure, Journal of the TEXTILE Association, pp. 360-366, April 2014.
126. M.E. Yuksekkaya, T. Howard, S. Adnaur, Influence of the fabric properties on fabric stiffness for industrial fabrics, Tekstil ve Konfeksiyon, April 2008.
127. K. Smith, A.A. Ogale, R. Maugans, L.K. Walsh, R.M. Patel, Effect of bond roll pattern and temperature on the micro structure and properties of polyethylene nonwoven, Textile Res. J. Vol. 70, No. 10, pp. 845-853, 2003.
128. K.Y. Wei, T.L. Vigo, structure-property relationships of thermally bonded polypropylene nonwovens, Journal of Applied Polymer Science, Vol. 30, pp. 1523-1534, 1985.

129. H. Rong, G.S. Bhat, Binder fibre distribution and tensile properties of thermally point bonded cotton based nonwovens, *Journal of Applied Polymers Science*, Vol. 91, pp. 3148-3155, 2004.
130. T. Zhang and T. Luo, Morphology-influenced thermal conductivity of polyethylene single chains and crystalline fibres, *J. of Applied Physics*, No.112, 2012.
131. A. N. Desai, N. Balasubramanian, Critical factors affecting the properties of thermal-bonded nonwovens with special reference to cellulosic fibres, *Indian journal of Fibre & Textile Research*, vol. 19, pp. 209-215, Sep. 1994.
132. H. Wang, J. Zhu, X. Jin, H. Wu, A study on the entanglement and high strength mechanism of spunlaced nonwoven fabrics of hydrophilic PET fibres, *Journal of Engineered Fibres and Fabrics*, Vol. 8, No. 4, 2013.
133. L. B. Suragani Venue, E. Shim, N. Anantharamaiah, B. Pourdeyhimi, Structures and properties of hydroentangled nonwoven: effect of number of manifolds, *The journal of the textile institute*, April 2016.
134. B. Pourdeyhimi, A. Minton, Structure-Process-Property Relationships In Hydroentangled Nonwoven-Part 1: Preliminary Experimental Observations, *International Nonwoven Journal*, Vol. 13, No. 4, January 2005.
135. Muhammad Tausif, Stephen J. Russell, Influence of hydroentangling variables on the properties of bi-layer polyethylene terephthalate-glass fabrics, *Textile Research Journal*, Vol. 82. No. 16, pp. 1677-1688 2012.
136. M. Ghane, M. Sheikhzadeh, S. Khaburi, I Ghaeli,; Investigation on the Ratio of Bending Rigidity of Fabric to Yarn for Low Twist Filament Yarn, *FIBRES & TEXTILES in Eastern Europe*, Vol. 17, No. 3(74), pp. 51-53, 2009.
137. T. Komori, M. Itoh, A. Takaku, Analysing the compressibility of a random fibre mass based on modified theory of fibre contact, *Textile Res. J.*, Vol.67, pp. 204-210, 1997.
138. N. Bahari, H. Hasani, M. Zarrebini and S. Hassanzadeh, Investigating the effects of material and process variables on the mechanical properties of low-density thermally bonded nonwoven produced from estabragh (milkweed) natural fibers, *Journal of Industrial Textiles*, pp. 1-18, 2015.
139. M. Emin, T. Howard, S. Adanur, Influence of the Fabric Properties on Fbaric stiffness for the industrial fabrics, *TEKSTIL ve KONFEKSiYON*, vol.4, pp. 263-267, 2008.
140. P. Birrfelder, M Dorrestijn, C. Roth, R M Rossi, Effect of fibre count and knit structure on intra and inter-yarn transport of liquid water, *Textile Research Journal*, Vol. 83 (14), pp. 1477-1488, 2013.

141. M. Parada, D. Derome, RM Rossi, J. Carmeliet, A review on advanced imaging technologies for quantification of wicking in textiles, *Textile Research Journal*, 2016.
142. Bernard Miller, Critical Evaluation of Upward Wicking Tests, *International Nonwoven Journal*, vol.9, No.1, 2000.
143. D.L. Carter, D.O. Shah, The role of surface tension on the residual water content of fabrics, *Journal of Surfactants and Detergents*, vol. 8, No. 1, pp. 91-94, January 2005.
144. Lampila, Erkki, Hydroentangled nonwoven, method for its manufacture and its use, EP 1091035 A1, Aril 2004.
145. T.J. Connolly and L. R. Parent, Influence of specific energy on the properties of hydroentangled nonwoven fabrics, *Tappi Journal*, vol. 76,pp. 135-141, 1993.
146. E. Ghassemieh, M. Acar, K. Versteeg, Improvement of the efficiency of energy transfer in the Hydroentanglement process, *Composite Science and Technology*, Vol. 61, pp. 1681-94, 2001.
147. E. Ghassemieh, M. Acar, H. K. Versteeg, Microstructural analysis of nonwoven fabrics using scanning electron microscopy and image processing. Part 2: application to hydroentangled fabrics, *Materials, Design and Applications*, vol.216, No.4,pp. 211-218, 2002.
148. S. Debnath, M. Madhusoothanan, Compression Properties of Polyester Needle-punched Fabric, *Engineered Fibres and Fabrics*, Vol. 4, No.4, pp. 14-19, 2009.
149. N.A. Teixeira, M.M. Platt, W.J. Hamburger, Mechanics of Elastic Performance of Textile Materials, Part XII: Relation of Certain Geometric Factors to the Tear Strength of woven Fabrics, *Textile Research Journal*, vol. 25,pp. 838-861, 1995.
150. P. R. Lord, M.H. Mohamed, *Weaving: Conversion Yarn to fabric*, Merrow Publishing Co. Ltd, England, 1994.
151. N. Kotb, A. El Geiheini, A. Salman, A. Abdul samad, Engineering of Tearing Strength for Pile Fabrics, *Journal of Textile and Apparel, Technology and Management*, Vol. 6, Issue 1, 2009.
152. S. S. Pavlovic, S. B. Stankovic, D.M. Popovic, G. B. Paporic, Transient thermal response of textile fabric made of natural and regenerated cellulose fibers, *polymer testing*, vol.34, pp. 97-102, 2014.
153. L. Milenkovic, P. Skundric, R. Sokolovic, T. Nikolic, Comfort properties of defence protective clothing, *The Scientific Journal Facta Universitatis*, vol. 1, pp. 101-106, 1999.

154. P. Kandhavativu, R. Rathinamoorthy, R. Surjit, Moisture and thermal management properties of woven and knitted tri-layer fabrics, *Indian j. of fibre and textile research*, vol.40, pp. 243-249, 2015.
155. G. Mazzuchetti, G. Lopardo, R. Demichelis, Influence of nonwoven fabrics' physical parameters on thermal and water vapour resistance, vol. 36, no.3, pp. 253-264, 2007.
156. E. Onofrei, A. M. Rocha, A. Catarino, The influence of knitted fabric's structure on the thermal and moisture management properties, *Journal of Engineered Fibres and fabrics*, vol.5 (4), pp. 10-23, 2011.
157. D. Kopitar, Z. Skenderi, B. Mijovic, Study on the influence of calendaring process on thermal resistance of polypropylene nonwoven fabric structure, *journal of fibre Bioengineering and informatics*, Vol. 7, PP. 1-11, 2011.
158. B. Das, A. Das, V.K. Kothari, R. Fanguero, M. de Araujo, Moisture Transmission Throgh textile, Part II: Evaluation methods and mathematical modelling, *AUTEX Research Journal*, Vol. 7, No. 3, September 2007.
159. F. Hajjani, S.M.H. Varkiyani, A. A. A. Jeddi, N. Ansari, The influence of water jet pressure on absorbency of spunlace nonwoven, 7th International Conference, TEXSCI, Liberec, Czech Republic, 6-8 Sep. 2010.
160. Z.A.Malik, M.H. Malik, T. Hussain, F.A. Arain, Development of Models to Predict Tensile Strength of Cotton Woven fabrics, *Journal of Engineered Fibres and Fabrics*, vol. 6, No.4, pp. 46-52, 2011.
161. S. Gaan, P. Rupper, V. Salimova, M. Heuberger, S. Rabe, F. Vogel, Thermal decomposition and burning behaviour of cellulose treated with ethyle ester phosphoramidates: Effect of alkyl substituent on nitrogen atom, *Polym Dergad Stab*, Vo. 94, pp. 1125-1134, 2009
162. G. Emad, M. Olfat, Designing and producing women's blouses by using nonwoven fabrics, *Internaltional Design Journal*, vol. 4, No. 2, pp. 137-151, 2001
163. A. Erik, M.J. Ole, H. L. Einar, B. D. Marianne, G. Kristin, Relationships between the properties of fibres and thermal bonded nonwoven fabrics made pf polypropylene, *Journal of Applied Polymer Science*, pp. 1633-1645, 1995

164. H.S. Kim, H.Ito, T. Kikutani, N. Okui, The thermal bonding behaviour of polyethylene/poly(ethylene terephthalate) bicomponent fibres, The journal of the Textile Institute, Vol. 88 No. 3, pp. 37-51, 1997
165. B. Pourdeyhimi, N.V. Fedorova, S.R.Sharp, Light weight high-tensile, high-tear strength bicomponent nonwoven fabrics, US patent, 7,438,777 B2, Oct. 2006
166. S. Ghosh, M. Dever. H. Thomas, C. Tewksbury, Effects of selected fibres properties and needlepunch density on thermally-treated nonwoven fabrics, IJFTR, Vol. 19, pp. 203-208, 1994
167. H. Rong, R. V. Leon, G. S. Bhat, Statistical Analysis of the effect of processing condition on the strength of thermal point-bonded cotton based nonwovens, Textile Res. J. Vol. 75, PP. 35-38, 2005
168. [www.nonwovensnetwork.com/fashion/2008/index.html](http://www.nonwovensnetwork.com/fashion/2008/index.html), Visited on 25/05/2016
169. [www.tappi.org](http://www.tappi.org), Visited on 16/02/2016
170. <http://www.lenzing-fibers.com/tencel>, Visited on 14/03/2016
171. S.C. Anand, IMRI, Private communication, University of Bolton, May 2016
172. H. Rong, "Wet-laid nonwovens (educational Research)." from [http://www.apparesearch.com/Education/Research/Nonwoven/2001\\_Kermit\\_Duckett/education\\_research\\_nonwoven\\_wet-laid\\_nonwovens.htm](http://www.apparesearch.com/Education/Research/Nonwoven/2001_Kermit_Duckett/education_research_nonwoven_wet-laid_nonwovens.htm), visited on june 2013

173. H. Lim, A review of spunbond process, Journal of Textile and apparel Technology and Management, Vol. 6, No.3 PP. 1-13, 2010
174. Textile nonwoven lab, University of Bolton
175. Textile nonwoven lab, University of Leeds
176. <http://nptel.ac.in/courses>, visited on May, 2013
177. EN ISO 3356:1990
178. EN ISO 13934-1:1999
179. BS EN ISO 9237, 1995
180. BS EN ISO 9073-6:2003
181. H. Ventura, M. Ardanuy, X. Capdevila, F. Cano, J.A. Tornero, Effect of needling parameters on some structural and physic-mechanical properties of needle-punched nonwovens, The journal of Textile Institute, Vol. 105, No. 10, PP. 1065-1075, 2014
182. G.K. Tyagi, A. Goyal, R. Chattopadhyay, Physical characteristics of tencel-polyester and tencel-cotton yarns produced on ring, rotor and air-jet spinning machines, indian Journal of Fibre & Textile Research, Vol. 38, PP. 230-236, 2013
183. [www.es.fibrevisions.com](http://www.es.fibrevisions.com) visited on 15/06/2015





