

## FACTORS INFLUENCING CONSUMER ETHICAL DECISION MAKING OF PURCHASING PIRATED SOFTWARE: STRUCTURAL EQUATION MODELING ON MALAYSIAN CONSUMER

**Ahasanul Haque**

*Faculty of Business Administration, International Islamic University, Malaysia*

**Sabbir Rahman**

*Graduate Research Student, Faculty of Business Administration  
International Islamic University, Malaysia*

**Ali Khatibi**

*Graduate Management Center, Management and Science University, Malaysia*

**Abstract:** The study explores the factors influencing consumer ethical decision making when purchasing pirated software. 300 questionnaires were distributed among potential respondents for this study, of which 250 were returned. After completing the screening process, only 200 responses were considered complete and valid to undergo data analysis. In this study, exploratory factor analysis was used to identify the salient attributes that impact consumer ethical decision making when purchasing pirated software. In addition, SEM (Structural Educational Modeling) was employed to identify the relationship among the variables. The results of the study showed that there is a significant relationship between consumer moralities, social influence, and consumer moral judgment towards the consumer ethical decision-making when purchasing pirated software. The outcome of this research showed a comprehensively integrated framework allowing policy makers and business enterprises to explore dimensions like morality, social influences and moral judgment and their effect on the consumer's decision-making in purchasing pirated software. However, further research is needed to examine these factors in Malaysia with additional samples before generalizations can be accurately made.

**Keywords:** consumer behavior, software piracy, ethics, consumer morality, social influence, moral judgment

### Introduction

Piracy has become a major problem for the software industry. The common research framework in studies of software piracy is based in the domain of ethical decision-making. However, certain studies suggest that many individuals do not treat software piracy as an ethical matter (Glass & Wood, 1996).

Malaysia, being a developing Asian nation and heading for a fully developed nation status by the year 2020, deals with piracy problems also faced by other Asian countries. In fact, in Malaysia, companies are losing money due to their products being substituted by pirated imitations. The Malaysian government continuously attempts to eliminate piracy to permit economic growth. According to the Business Software Alliance's (2000), the intensity of software piracy in Malaysia is increasing at an alarming rate.

Givon, et al. (1995) estimated that US industries lose sales revenue of \$17 billion annually to consumer piracy. In the decade since, the problem has not disappeared or abated. If anything, piracy is even more severe now than these estimates suggest. The estimated annual trade losses for software companies in Spain due to copyright piracy amounted to \$173.8 million ([www.iipa.com/rbc/1998/rbc\\_spain\\_301\\_98.html](http://www.iipa.com/rbc/1998/rbc_spain_301_98.html)); the US motion picture industry loses about \$2.5 billion annually because of the failure of governments to protect its intellectual property ([www.mpa.org/legislation/press/98/98\\_5\\_21a.htm](http://www.mpa.org/legislation/press/98/98_5_21a.htm)); and the International Federation of the Phonographic Industry (IFPI) estimated that pirated disk sales jumped from 640 million units in 2000 to 950 million units in 2001, totaling close to \$4.3 billion (Mariano, 2002, <http://news.com.com/2100-1023-935120.html>).

According to Haque, et al. (2009), piracy is an activity that carries a much greater threat to the economy, and social and cultural well being of a nation than generally realized by the consumer. Moreover, it is an activity where short-term gains are achieved at the expense of long-term disadvantages. They also state that China, Thailand, India and Malaysia are known as the 'home for piracy'. Consequently, consumers are facing problems when attempting to distinguish the pirated products from the original ones. For instance, which one will they will buy; because the price of the original products are much higher than the pirated one. Although Atallah, et al. (2008) make clear demarcation lines on the issue of piracy; it is continuously expressed that the battle against piracy is a difficult fight and much pragmatism is required in deciding when and how to target the pirates. This paper proposes a statistical model to reflect the relationship of various theories and empirically hypothesized relationships of the factors that influence the consumer's decision when purchasing pirated software in Malaysia. Furthermore, it examines the influence of three important factors: consumer morality, social influence, and moral judgment on the ethical decision process of the consumer in Malaysian perspectives.

## **Literature Review**

In our research, we have explored what numerous studies have concluded over the years on whether consumer ethical attitudes are a key factor influencing software piracy (Ening & Christensen, 1991; Haque, et al., 2009; Logsdon, et al., 1994; Taylor & Shim, 1993). Since software piracy is illegal, the decision to purchase pirated software creates some stimuli that occur in the mind of consumers' on certain ethical dilemmas, which affect their ethical decision process (Tan, 2002).

### ***Consumer Morality***

Studies have dealt with the impact of ethics on intent to use or on actual use of pirated products, i.e. software, clothes, and electronics (e.g. Babin & Griffin, 1995; Cordell, et al., 1996; Vitell, et al., 1991). Rest (1979) developed a model which depicts the ethical decision making process of an individual consumer when he or she intends to buy a pirated product. The model instructs that a person must first recognize the moral issue; then make a moral judgment and establish moral intent; and lastly, implement moral actions in the ethical decision-making process.

At the organizational level, moral standards influence policies and regulations concerning the ethical use of software. Unfortunately, traditional morality cannot characterize the piracy problem with any clarity (Johnson, 1995) because individuals confronted with ethical problems traditionally attempt to resolve them by appealing to moral standards and moral reasoning. Moral standards can be applied at

either the organizational or the individual level (Lau, 2006). Much of the ethical debate concerning software piracy is fueled by the question of what a “right” practice should be – ranging from maximizing the good of society to respecting the rights of stakeholders, such as software developers and computer professionals (Lau, 2006).

Logsdon, et al. (1994) applied Kohlberg’s theory of moral states to determine if higher levels of morality resulted in a lower consumption of pirated software. They examined 263 undergraduate and graduate students in the USA under the assumption that graduate students operate at a higher moral level because of their greater maturity, and thus, use less pirated software. The study disproved the underlying premise. In fact, graduate students consumed higher amounts of pirated software. Thus, from the overall discussion, we propose the following null hypothesis:

*H1: Consumer morality is not significant in ethical decisions regarding purchasing pirated software.*

### ***Social Influence***

Lee, et al., (1994), Vice President of Business Software Alliance, expressed that piracy in Malaysia is a social economic problem that affects all levels of society. Swinyard, et al. (1990) found that Asians adopt a more casual attitude towards software piracy than Americans, which they attributed to cultural differences. Husted’s (2000) study documented that per capita GNP, income inequality, and individualism were correlated with the degree of software piracy. Sims, et al. (1996) profiled students by their likelihood of using pirated software, and used gender (males pirated more), age (no difference), and PC familiarity (the greater it was, the stronger the pirating tendencies) as explanatory variables. The most important reasons for using pirated software were the cost of the original, and wanting to try it first before purchasing (Cheng, et al., 1997).

Social pressures can influence individuals to follow rules, as well as break them. The extent to which consumers are influenced by social pressures is dependent on their susceptibility to such pressures (Bearden, et al., 1989). According to him, consumer susceptibility is “the need to identify with or enhance one’s image in the opinion of significant others through the acquisition and use of products and brands, the willingness to conform to the expectations of others regarding purchase decisions, and the tendency to learn about products by observing others or seeking information from others.” Thus, the second null hypothesis used in our study is:

*H2: Social influence does not have significance with ethical decision on purchasing pirated software.*

### ***Moral Judgment***

Wagner and Sanders (2001) state that moral equity affects behavioral intention directly and indirectly (through ethical judgments) and actual behavior is determined by such intentions. Hence, this research includes morality, moral judgment (Tan, 2002; Wagner & Sanders, 2001; Kuo & Hsu, 2001). Individuals confronted with ethical problems traditionally attempt to resolve them by appealing to moral standards and moral reasoning. Moral standards can be applied at either the organizational or the individual level (Lau, 2006). Thus we can develop the third null hypothesis:

*H3: Moral judgment is not related with the ethical decision in purchasing pirated software.*

### Theoretical Framework

Based on the literature review, this research concentrates on a framework of factors influencing consumer ethical decision-making when purchasing pirated software. This framework emphasizes those variables such as salary/income, attitude and culture. These independent variables are positively related to the consumers' ethical decision making in purchasing pirated software. The detailed diagram framework is given below:

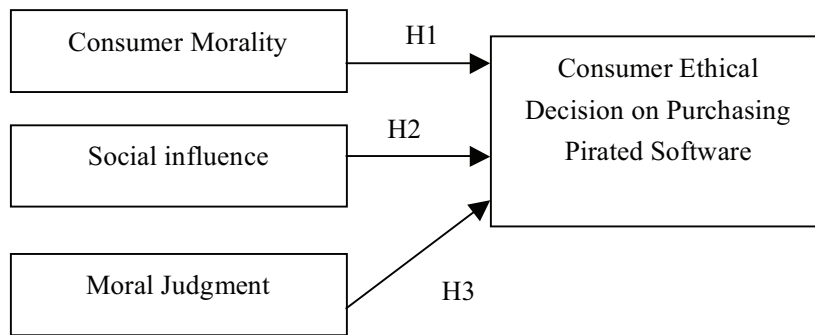

Figure 1. Factors influencing of Consumer Ethical Decision on Purchasing Pirated Software

### Methodology

Since the major purpose of the study is to figure out the factors of the ethical decision on purchasing pirated software, a self-structured questionnaire was developed to collect the required primary data from inhabitants of the Selangor state in Malaysia. Primary data was collected randomly from the general people in the Klang Valley area by using convenience-sampling procedures. The questions were categorized and structured under the independent variables chosen and discussed in the literature review. Questions were asked of all three races of people in Malaysia: Malay, Chinese, and Indian. Zikmund and Babin (2007) argued that researchers generally use convenience samples to obtain a large number of completed questionnaires quickly and economically, or when obtaining a sample through other means is impractical. This method produces a large number of responses quickly and at a low cost. Convenience samples are best used for exploratory research when additional research will subsequently be conducted with a probability sample. The sampling frame for conducting the principal component analysis is comprised of 200 respondents, which have been taken from different races comprising of both male and female participants. A 7-point scale was used, ranging from 'strongly disagree' to 'strongly agree'. A total of 300 sample sizes were found to be valid and distributed among the potential respondents for this study, of which 250 questionnaires were received. Each of the responses received was systematically screened for errors, and incomplete or missing responses. After completing the screening process, only 200 responses were considered complete and valid for a data analysis. This represents a success rate of 66%, which is considered to be extremely good in view of time, cost, certainty and geographical constraints. In this study, exploratory factor analysis was used to identify the salient attributes that impact consumer ethical decision-making when purchasing pirated software. Since factor analysis represents an analytical process of transforming statistical data (as measurements) into linear combinations of variables, it is a meaningful statistical method used to combine a large number of data into a considerably smaller number

of factors with a minimal loss of information (Hair, et al., 2006). In addition, SEM (Structural Educational Modeling) has been carried out to investigate the relationship among the variables that influence the factors of ethical decisions in purchasing pirated software.

## Data Analysis

### *Reliability Coefficient*

In order to measure the reliability for a set of two or more constructs, Cronbach alpha is a commonly used method where alpha coefficient values range between 0 and 1, with higher values indicating higher reliability among the indicators (Hair, et al., 2006). Hence, 1 is the highest value that can be achieved (Table 1). In accordance with the Cronbach alpha test, the total scale of reliability for this study varies from .90 to .98, indicating overall high reliability factors. The reliability of this study is substantial in every perspective.

**Table 1. Reliability Analysis for all Variables**

| Cronbach's Alpha | Cronbach's Alpha based on Standardized Items | N of Items |
|------------------|--|------------|
| .883             | .884   | 21         |

### *Factor Analysis*

The results obtained from 200 respondents were thoroughly analyzed. In applying SPSS, Principal Component Analysis (PCA) was carried out to explore the underlying factors associated with the 21 items. The constructs validity was tested using Bartlett's Test of Sphericity and The Kaiser-Mayer-Olkin Measure of sampling adequacy to analyze the strength of association among the variables. The Kaiser-Mayer-Olkin measures of sampling adequacy (KMO) were first computed to determine the suitability of employing a factor analysis. KMO is used to assess which variables to drop from the model due to multi-collinearity problems. The value of KMO varies within 0 and 1, and the KMO overall value should be 0.60 or higher to perform a factor analysis. If this is not achieved, then it is necessary to drop the variables with the lowest anti image values until the KMO composite value rises above .60. The results extrapolated from the Bartlett's Test of Sphericity and KMO reveal that the factors were highly significant and eventually concluded that these variables were suitable for a factor analysis (Table 2).

**Table 2. KMO and Bartlett's Test**

|   |                    |
|---|--------------------|
| Kaiser-Meyer-Olkin Measure of Sampling Adequacy | .878               |
| Bartlett's Test of Sphericity                   | Approx. Chi-Square |
|   | df                 |
|   | Sig.               |
|   | 873.754            |
|   | 81                 |
|   | .000               |

To determine the minimum loading necessary to include an item in its respective construct, Hair et al. (2006) suggested that variables with loading greater than 0.30 are considered significant, loading greater than 0.40 are more important, and loading 0.50 or greater are very significant. For this study, items with loading of 0.40 or greater were accepted. The results also showed the total variance explained for the

three factors to be 63.050%. The values of the following Table 2 indicate the affiliation of the items to a factor. Generally, the factor is the natural affinity of an item for a group. The higher loading (factor) indicates the stronger the affiliation of an item is to a specific factor. The findings of this study indicate that each of the three dimensions (Consumer Morality, Social influence, and Moral judgment) were homogeneously loaded to different factors. That means each of the dimensions that loaded into three different factors, all have proven to be significantly related to the consumer ethical decision making when purchasing pirated software.

**Table 3. Factor Loading Matrices Following Rotation of Three-Factor Solutions**

| Descriptions  | F1   | F2   | F3   |
|---|------|------|------|
| <b>Consumer Morality</b>  |      |      |      |
| (cm1) Thinking of impact on the revenue of the original software company.   |      | .772 |      |
| (cm2) Thinking of impact on the revenue of the software seller.   |      | .743 |      |
| (cm3) Self motivated of not to buy pirated software   |      | .691 |      |
| (cm4) Feeling of guilty after buying pirated software   |      | .688 |      |
| (cm4) Feeling of Criminal offence   |      | .672 |      |
| <b>Social influence</b>   |      |      |      |
| (si1) Encouraged by others not to buy pirated software  | .825 |      |      |
| (si2) Institution provide Knowledge on piracy   | .808 |      |      |
| (si3) Socially accepted of buying original software   | .789 |      |      |
| (si4) Friends are against of buying pirated software unethical  | .655 |      |      |
| <b>Moral judgment</b>   |      |      |      |
| (mj1) Buying pirated software other than original   |      |      | .853 |
| (mj2) Feeling of erroneous of buying pirated software   |      |      | .808 |
| (mj3) Self concept to purchase pirated product  |      |      | .680 |
| <b>Notes:</b> Extraction Method: Principal Component Analysis.<br>Rotation Method: Varimax with Kaiser Normalization. Rotation converged in 5 iterations. |      |      |      |

### **Reliability Test**

Reliability is the degree to which the observed variable measures the “true” value and is “error free.” If the same measure is asked repeatedly, more reliable measures will show greater consistency than less reliable measures (Hair, et al., 2006). The coefficient alpha estimates for the multi-item scales used in this study are presented in Table 4. Reliability coefficients (Cronbach’s Alpha) were computed for the items that formed each factor. The reliability coefficients for the three factors: Consumer Morality, Social influence, Moral judgment were 0.823, 0.864, 0.781 respectively. As Table 4 shows, all alpha coefficients for the data exceed the minimum standard for reliability of 0.70 recommended by Nunnally (1978) for basic research. Thus, the results indicate that these multiple measures are highly reliable for measuring each construct.



**Table 4. The Reliability Coefficients for Derived Factors.**

| Factor            | Number of Cases | Number of Items | Cronbach's Alpha |
|-------------------|-----------------|-----------------|------------------|
| Consumer Morality | 200             | 5               | .823             |
| Social influence  | 200             | 4               | .864             |
| Moral judgment    | 200             | 3               | .781             |

**Confirmatory Factor Analysis (CFA)**

*Consumer Morality.* For consumer morality, the modification indices for the covariance of measurement errors were: 9.543 between cm2 (“Thinking of impact on the revenue of the software seller”) and cm1 (“Thinking of impact on the revenue of the original software company”) and 12.745 between cm4 and cm5 (“Feeling of guilty after buying pirated software” and “Feeling of Criminal offence”). These two sets of measurement errors are logically conceivable to be correlated. Therefore, these correlated relations were allowed in the model. Each pair was added to the measurement model one at a time. After adding these three parameters, testing of the revised measurement model showed:  $\chi^2/d.f. = 1.243$  ( $\chi^2=13.768$ , d.f.=11); GFI= .962, AGFI=.956, CFI=.981, NFI=.952 and RMSEA= .034.

*Social Influence.* From our EFA as shown in Table 3, we have retained four measuring items for social influence. We could retain all these items after conducting CFA; the default model fit indices of attitude were adequate. The examination of the modification indices revealed that the measurement errors 24.434 between si2 (“Institution provide knowledge on piracy”) and si4 (“Friends are against unethical buying pirated software”) were correlated. The logical possibility for the correlation was allowed; therefore, these measurement errors were allowed to be related. After adding this parameter, the measurement model fit indices of price showed an adequate fit:  $\chi^2/d.f. = .079$  ( $\chi^2=10.213$ , d.f.=6); GFI= .972, AGFI=.967, CFI=.968, NFI= .952 and RMSEA= .046.

*Moral Judgment.* From our EFA as shown in Table 3, we have retained 3 measuring items for moral judgment. We could retain all these items after conducting CFA, as all those indicators were loaded with a loading factor more than 0.50. The fit indices from the default measurement model were:  $\chi^2=.000$ , d.f.=0 (If the probability level cannot be computed, the model has zero degrees of freedom. The model should fit the data perfectly, and the chi-square statistic should be zero. Consequently, no probability level can be assigned to the chi-square statistic. The model is untestable.); GFI= 1.00, CFI=1.00, NFI=1.00 and RMSEA= .507. All indices represent an adequate fit of the model, except for the value of RMSEA. Therefore, there was no need to examine the modification indices.

**Structural Equation Modeling (SEM)**

Structural equation modeling (SEM) performed to test the hypothesized model using AMOS 7. SEM is known as a latent variable analysis or causal modeling as it provides parameter estimates for the direct and indirect links between observed variables. In Figure 2, boxes represent manifest or measured variables, whereas circles indicate latent or unobserved variables. As shown in Figure 4, the model's exogenous variables (Consumer Morality = cm, Social influence = si, Moral judgment= mj) were measured by an X variable. There are five indicators used for the construct of Consumer Morality = cm;

four indicators used for the construct of Social influence = si; three indicators used for the Moral judgment= mj. Similarly, the model's endogenous variables were measured by a Y (Consumer Ethical Decision on Purchasing Pirated Software) variable. Five indicators measured the construct of Consumer Ethical Decision on Purchasing Pirated Software (CEP).

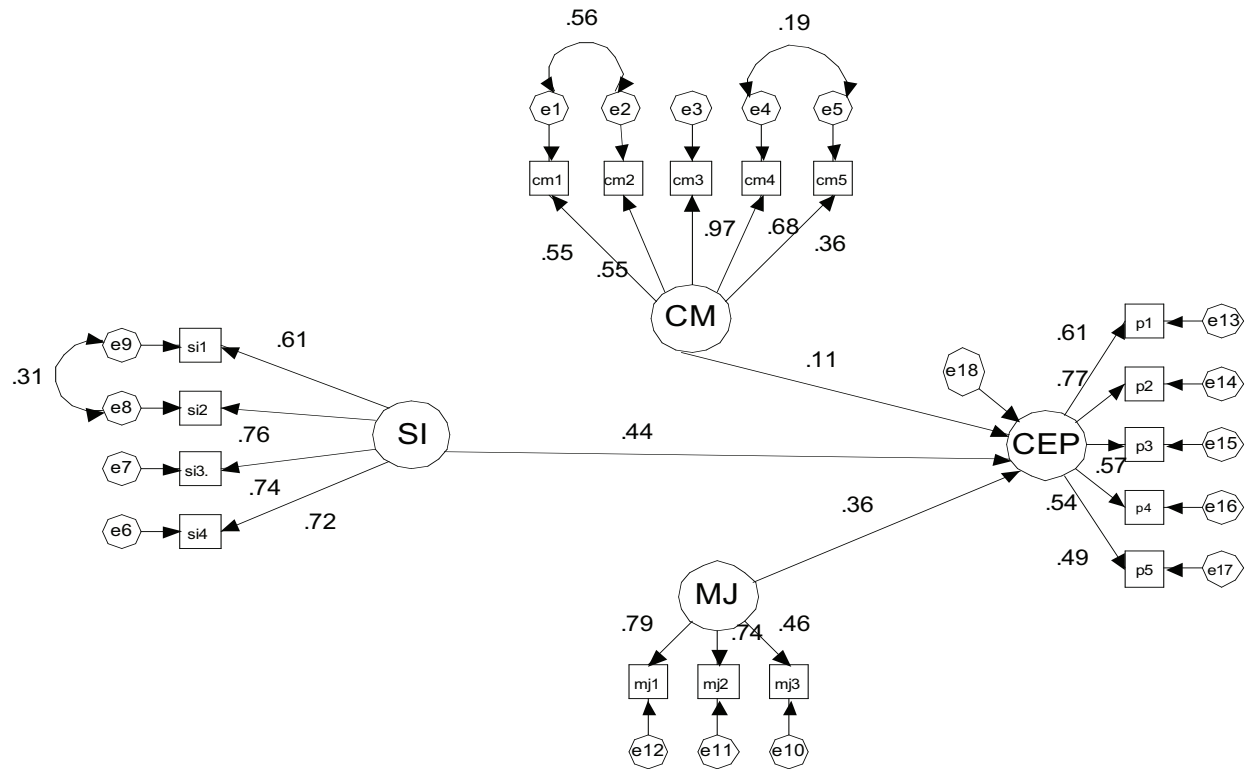

Figure 2. Factors influencing consumer ethical decision on purchasing pirated software model.

(For total sample): Default model

**Statistical Significance of Parameter Estimates**

The test statistic here is the critical ratio (C.R), which represents the parameter estimate divided by its standard error. As such, it operates as a z-statistic in testing that the estimate is statistically different from zero. Based on a probability level 0.05, then the test statistic needs to be  $\geq \pm 1.96$  before the hypothesis (which estimates equal 0.0) can be rejected. Nonsignificant parameters, with the exception of error variances, can be considered unimportant to the model; in the interest of scientific parsimony, albeit given an adequate sample size, they should be deleted from the model.



**Table 5. Standard Estimation of the Main Model**

| Standardized regression weight |                          |                                   | Estimate | S.E.  | C.R.  | P value |
|--------------------------------|--------------------------|-----------------------------------|----------|-------|-------|---------|
| H1                             | Consumer Morality (CM) ← | Purchasing Pirated software (CEP) | 0.127    | 0.041 | 3.948 | 0.000   |
| H2                             | Social influence (SI) ←  | Purchasing Pirated software (CEP) | 0.567    | 0.053 | 3.504 | 0.000   |
| H3                             | Moral Judgment(MJ) ←     | Purchasing Pirated software (CEP) | 0.405    | 0.206 | 3.281 | 0.000   |

### ***Hypotheses Testing***

The structural equation model was examined to test the relationship among constructs. Goodness-of-fit indicates for this model to be  $\chi^2/df = (316.457/167) = 1.894$ ,  $GFI = 0.846$ ,  $AGFI = 0.785$ ,  $CFI = 0.827$ ,  $NFI = 0.764$ . Figure 2 depicts the full model. Of the three paths hypothesized in the model, all the paths were significant at  $p < 0.05$ . (H1). Consumer morality is significant in the ethical decision made when purchasing pirated software. Therefore null hypotheses H1 is rejected at 0.5 level of significance  $p > 0.000$ . Regarding H2 (social influence is not significant in making the ethical decision on purchasing pirated software), our results revealed that social influence does have a strong significance in the ethical decision on purchasing pirated software. Therefore; this null hypothesis is also rejected at  $p < 0.000$ . The result also highlighted that individual's moral judgment is strongly related to the ethical decision on purchasing pirated software. Therefore, null hypotheses H3 is rejected as  $p > 0.000$ . Among all the significant variables, from our result, social influence and moral judgment is strongly related with the ethical decision consumers make when purchasing pirated software.

### **Conclusion and Implementation**

There were many factors that influenced a consumers' perception towards piracy. In this paper we mainly discussed consumer morality, social influence, and moral judgment. Hypotheses were developed for each of these variables showing the relationship that the variables have toward consumer ethical decision making when purchasing pirated software. When the Structural Equation Modeling test was run, consumer morality, social influence, and moral judgment showed that the null hypothesis should be rejected, concluding that there is a relationship between these variables and the dependent variable, which is the Consumer Ethical Decision Making When Purchasing Pirated Software.

According to Nissan (1991), there are two approaches that explain ethical behavior: slippery slope; and balanced book. The first one indicates that ethical deviations lead to ever-increasing transgressions. Bad deeds make individuals perceive themselves as bad, lowering their self-expectation, which ultimately

leads to more unethical behavior. Shoham, et al. (2008) said this argument is usually invoked against even small ethical deviations, which could lead to larger ones. The balanced book approach argues that slippery slopes do not necessarily exist for all individuals, exemplified by those who commit unethical acts that do not lead to larger transgressions (Reshef, 2001). While individuals want to behave ethically, they permit self-imperfections (Reshef, 2001). They deviate consciously, but judge themselves on a continuum of actions, some ethical, some not. Over time, good deeds improve and bad deeds impair the balance in the account (Shoham, et al., 2008). Moreover, people tend to cover their “moral overdraft” over time and use “moral reserves” to defend unethical choices (Nissan, 1993), or tendencies documented empirically (Nissan, 1991; Reshef, 2001). As a result, firms should advertise piracy as unethical. Firms also inform ethical individuals about the harm they suffer due to the unethical behavior of others. For example, an advertising campaign might emphasize the reduction in prices that might be made if software piracy were reduced. Such a campaign could try to persuade ethical consumers to take action, such as censuring their friends or not lending their legal copies of software to others to copy illegally.

### Limitation and Direction for Future Research

First, a convenience sample was used. Further research is needed with a random sample of consumers. This research has been applied successfully to what we have learned in the piracy related literature of pirated product with evidence from Malaysia. Given the interesting results of this study and the managerial imperative arising from the situation, future research should focus on several perspectives: innovative ways to increase moral equity; identify the best methods to increase marketing efficiency.

### References

- Atallah, M., O'Rourke, M., Mason, M., & Wade, J. (2008). Steal this article: Battening down the digital hatches. *Risk Management*, May, 26-35, ISSN 0035-5593.
- Babin, B. J., & Griffin, M. (1995). A closer look at the influence of age on consumer ethics. In F.R. Kardes, and M. Sujan (Eds), *Advances in Consumer Research*, Vol. 22, *Association for Consumer Research*, Provo, UT, pp. 668-73.
- Cheng, H. K., Sims, R. R., & Teegen, H. (1997). To purchase or to pirate software: An empirical study. *Journal of Management Information Systems*, 13(4), 49-60.
- Cordell, V. V., Wongtada, N., & Kieschnick, R. L., Jr. (1996). Counterfeit purchase intentions: Role of lawfulness attitude and product traits as determinant. *Journal of Business Research*, 35, 41-53.
- Eining, M. M., & Christensen, A. L. (1991). A psycho-social model of software piracy: The development and test of a model. In R. Dejoice, G. Fowler, & D. Paraddice (Eds.), *Ethical issues in information systems* (pp. 182-8), Boston: Boyd & Frasher Publishing Company.
- Givon, M., Mahajan, V., & Muller, E. (1995). Software piracy: Estimation of lost sales and the impact on software diffusion. *Journal of Marketing*, 59(1), 29-37.
- Glass, S. R., & Wood, A.W. (1996). Situational determinants of software piracy: An equity theory perspective. *Journal of Business Ethics*, 5(11), 1189-98.
- Hair, J. F., Babin, B., Anderson, R. E., & Tatham, R. L. (2006). *Multivariate data analysis* (6th ed.). London: Prentice Hall.

- Haque, A., Khatibi, A., & Rahman, S. (2009). Factors Influencing Buying Behavior of Piracy Products and its Impact to Malaysian Market. *International Review of Business Research Papers*, 5(2), 383-401.
- Husted, B. W. (2000). The impact of national culture on software piracy. *Journal of Business Ethics*, 26, 197-211.
- Johnson, D. G. (1995). *Computer Ethics* (2nd ed.). Englewood Cliffs, NJ: Prentice Hall.
- Kuo, F. Y., & Hsu, M. H. (2001). Development and validation of ethical computer self-efficacy measure: The case of soft lifting. *Journal of Business Ethics*, 32, 299-315.
- Lau, E. K. (2006). Factors motivating people toward pirated software. *Qualitative Market Research: An International Journal*, 9(4), 404-419
- Lee, G. M., Eining, M. M., & Long, C. P. (1994). Information ethics: A comparative among college students from Mainland China. *Hong Kong Journal of Business Management*, 12, 17-35.
- Logsdon, J. M., Thompson, J. K., & Reid, R. A. (1994). Software piracy: Is it related to level of moral judgment. *Journal of Business Ethics*, 13, 849-57.
- Mariano, G. (2002). "Using tax dollars to combat piracy", Cjnet, April 24, available at: <http://news.com.com/2100-1023-891521.html>
- Moor, J. H. (1985). What is computer ethics. *Metaphilosophy*, 16(4), 266-75.
- Nisan, M. (1991). The moral balance model: Theory and research extending our understanding of moral choice and deviation. In W.M. Kurtines & J.L. Gewirtz (Eds.), *Handbook of Moral Behavior and Development* (Vol. 3, pp. 213-249). Hillsdale, NJ: Erlbaum.
- Nisan, M. (1993). Balanced identity: Morality and other identity values. In G. Noam & T. Wren (Eds.), *The Moral Self*. Cambridge, MA: MIT Press.
- Nunnally, J. C. (1978). *Psychometric theory* (2nd ed.). New York: McGraw-Hill.
- Rest, J. R. (1979). *Development in judging moral issues*. Minneapolis, MN: University of Minnesota Press.
- Reshef, A. (2001). The need for business success versus moral principles: How do managers settle between the two? *Human Resources*, September/October, 20-7.
- Shoham, A., Ruvio, A., & Davidow, M. (2008). (Un)ethical consumer behavior: Robin Hoods or plain hoods? *Journal of Consumer Marketing*, 25(4), 200-210.
- Sims, R. R., Cheng, H. K., & Teegen, H. (1996). Toward a profile of student software pirates. *Journal of Business Ethics*, 15, 839-49.
- Swinyard, W. R., Rinne, H., & Kau, A. K. (1990). The morality of software piracy: A cross-cultural analysis. *Journal of Business Ethics*, 9, 655-664.
- Tan, B. (2002). Understanding consumer ethical decision making with respect to purchase of pirated software. *Journal of Consumer Marketing*, 19(2), 96-111.
- Taylor, G. S., & Shim, J. P. (1993). A comparative examination of attitudes toward software piracy among business professors and executives. *Human relations*, 46, 419-433.
- Vitell, S. J., Lumpkin, J. R., & Rawwas, M. W. A. (1991). Consumer ethics: An investigation of the ethical beliefs of elderly consumers. *Journal of Business Ethics*, 10(5), 365-375.
- Wagner, S. C., & Sanders, G. L. (2001). Considerations in ethical decision making and software piracy. *Journal of Business Ethics*, 29, 161-167.
- Zikmund, W. G., & Babin, B. J. (2006). *Essential of Marketing Research* (3rd ed.). Mason, OH: Thomson Higher Education.