

A large strain plasticity model for anisotropic composite materials

**E. Car
S. Oller
E. Oñate**

A Large Strain Plasticity Model for Anisotropic Composite Materials

**E. Car
S. Oller
E. Oñate**

Publication CIMNE N° 179 December 1999

**International Center for Numerical Methods in Engineering
Gran Capitán s/n, 08034 Barcelona, Spain**

Contents

1	Introduction	3
2	Anisotropic material in large strains	4
2.1	A brief introduction to the anisotropic model in small strains . . .	4
2.1.1	Constitutive equation	5
2.1.2	Yield and plastic potential functions	5
2.1.3	Translation of stresses from the anisotropic to the isotropic space	6
2.1.4	Transformation of strains from the anisotropic to the isotropic space	7
2.2	Definition of the elasto-plastic isotropic model in large strains . .	8
2.2.1	Small elastic and large plastic strain case. Free energy expression	10
2.2.2	Constitutive equation	10
2.2.3	Yield condition	10
2.2.4	Flow rule	11
2.2.5	Tangent elasto-plastic constitutive tensor	11
2.2.6	Constitutive tensor constant on the updated configuration	11
2.2.7	Constitutive tensor constant in the reference configuration	13
2.3	Extension of the anisotropic theory to large strain	13
2.3.1	Material formulation	13
2.3.2	Formulation on the updated configuration	15
2.3.3	Flow rule and evolution law for the internal variables . . .	17
3	Anisotropic composite material model	18
3.1	Introduction	18
3.2	Mixing Theory	19
4	Numerical example. Shear test of a composite specimen	22
5	CONCLUDING REMARKS	26
	References	31

Contents

1	Introduction	3
2	Anisotropic material in large strains	4
2.1	A brief introduction to the anisotropic model in small strains . . .	4
2.1.1	Constitutive equation	5
2.1.2	Yield and plastic potential functions	5
2.1.3	Translation of stresses from the anisotropic to the isotropic space	6
2.1.4	Transformation of strains from the anisotropic to the isotropic space	7
2.2	Definition of the elasto-plastic isotropic model in large strains . .	8
2.2.1	Small elastic and large plastic strain case. Free energy expression	10
2.2.2	Constitutive equation	10
2.2.3	Yield condition	10
2.2.4	Flow rule	11
2.2.5	Tangent elasto-plastic constitutive tensor	11
2.2.6	Constitutive tensor constant on the updated configuration	11
2.2.7	Constitutive tensor constant in the reference configuration	13
2.3	Extension of the anisotropic theory to large strain	13
2.3.1	Material formulation	13
2.3.2	Formulation on the updated configuration	15
2.3.3	Flow rule and evolution law for the internal variables . . .	17
3	Anisotropic composite material model	18
3.1	Introduction	18
3.2	Mixing Theory	19
4	Numerical example. Shear test of a composite specimen	22
5	CONCLUDING REMARKS	26
	References	31

A Large Strain Plasticity Model for Anisotropic Composite Materials

E. Car*, S. Oller* y E. Oñate†

*Departamento de Resistencia de Materiales y Estructuras en la Ingeniería

E.T.S. Ingenieros de Caminos, Canales y Puertos

Universidad Politécnica de Catalunya

† Centro Internacional de Métodos Numéricos en Ingeniería

Universidad Politécnica de Catalunya

Jordi Girona 1-3 Módulo C1 Campus Norte UPC,08034 Barcelona, España

email: car@cimne.upc.es, email: oller@cimne.upc.es, email: onate@cimne.upc.es

Submitted to

International Journal of Plasticity

Special Issue on Computational Modeling of Forming Processes

Guest Editors: C. Agelet de Saracibar and M. Cervera

Abstract

In this work a generalized anisotropic model in large strains based on the classical isotropic plasticity theory is presented. The anisotropic theory is based on the concept of mapped tensors from the anisotropic real space to the isotropic fictitious one. In classical orthotropy theories it is necessary to use an special constitutive law for each material. The proposed theory is a generalization of classical theories and allows the use of models and algorithms developed for isotropic materials. It is based on establishing a one-to-one relationship between the behavior of an anisotropic real material and that of an isotropic fictitious one. Therefore the problem is solved in the isotropic fictitious space and the results are transported to the real field. This theory is applied to simulate the behavior of each material in the composite. The whole behavior of the composite is modeled by incorporating the anisotropic model within a model based on a modified mixing theory.

1 Introduction

An anisotropic material is one which exhibits properties with different values when measured in different directions. Modeling the behavior of an elastic anisotropic solid does not present big difficulties. In this case, it is possible to use the general elasticity theory (Hull, 1987), (Pendleton and Tuttle, 1989), (Matthews and Rawlings, 1994), etc. The formulation of a constitutive law adequate to simulate the non-linear behavior of orthotropic or anisotropic solids such as fiber reinforced composites is a complex task. The main objective of this work is to present a general theory which allows to model the non-linear constitutive behavior of this type of materials.

The general formulation of anisotropic yield surfaces should describe the behavior of isotropic materials as a particular case. When the yield surface of an isotropic material is obtained as a particular case of an anisotropic one, it must have the properties of isotropic functions described by Gurtin (1981).

The first attempts to formulate yield functions for orthotropic materials are due to Hill who was able to extend the isotropic Von Mises model to the orthotropic case (Hill, 1948, 1971, 1979, 1990). The main limitation of this theory is the impossibility of modeling materials that present a behavior which not only depends on the second invariant of the stress tensor, i.e. the case of geomaterials or composite materials. Several authors proposed yield functions in the anisotropic stress space. (Bassani (1977) , Budiansky (1984) and Barlat et. al. (1989, 1991)). In 1991 Barlat et. al. proposed a linear transformation of the stress state of an anisotropic material by multiplying all the components of the stress tensor by different constants. Many authors have used four rank tensors in the formulation of yield functions for anisotropic materials, see, for instance Shih and Lee (1978) , Eisenberg and Yen (1984) and Voyiadjis and Foroozesh (1990). In 1982 Dvorak and Bahei-El-Din used tensorial operators with a Von Mises yield function to simulate the behavior of composite materials. In 1993 Karafillis and Boyce proposed a general expression of yield surfaces of polycrystalline materials which allows to describe isotropic and anisotropic materials. The anisotropy of the material is described with a set of irreducible tensorial variables. This set of variables allows to make a linear transformation of the stress state of the anisotropic material to an Isotropic Plasticity Equivalent Material (IPE). Later, Voyiadjis and Thiagarajan (1995) based on previous works, proposed a general yield surface which depends on a four rank tensor and applied this model to study the behavior of unidirectional fiber reinforced composites.

The non-linear anisotropic theory developed in this work is a generalization of the classic isotropic plasticity theory (Malvern, 1969) (Lubliner, 1990). It is based in a one-to-one transformation of the stress and strain spaces by means of a four

rank tensor. This transformation preserves the convexity of the plastic potential and the yield functions which assures that the material does not return to an elastic state once it has reached a plastic state under monotonically growing loads. Applications of this theory to the linear and non-linear analysis of composites under small and large strains conditions were reported in previous works of the authors. (Oller et al., 1993a, 1995a) (Car et al., 1999)

The layout of the paper is the following. In the next section the constitutive model for anisotropic materials undergoing large strains is described. The treatment of the anisotropic behavior of the overall composite using mixing theory is then presented. The accuracy and potential of the anisotropic model is tested in the failure analysis of a composite specimen for which experimental results are available.

2 Anisotropic material in large strains

2.1 A brief introduction to the anisotropic model in small strains

The anisotropic theory developed in this work is based on the ideas proposed by Betten (Betten, 1981, 1988) and uses the concept of *mapped tensors*. This concept allows to use the advantages and algorithms developed for classic isotropic materials. The implementation of this theory in finite element codes is straightforward.

Several authors have developed a generalization of the classic isotropic plasticity theory to the anisotropic case (Betten, 1981, 1988)(Oller et al., 1993a, 1993b). The basic idea consists of modeling the behavior of an *anisotropic real solid* by means of a *fictitious isotropic solid*. A basic assumption of this model is that the elastic strain is unique for the anisotropic and isotropic solids. This hypothesis introduces a limitation in the theory, because it involves a proportionality concept between the yield strength and the elasticity modulus for each material direction.

The constitutive model presented in this work is more general and it can simulate high anisotropic materials, such as fiber reinforced composites. The anisotropic behavior of the material is expressed in terms of an isotropic fictitious stress and strain spaces which are the linear tensor transformations of the real anisotropic stress and strain spaces. All the information on the material anisotropy is contained in the fourth order transformation tensors A^σ and A^ϵ relating the stresses and strains in the real (anisotropic) and fictitious (isotropic) spaces. The parameters that define the transformation tensors can

be calibrated from adequate experimental tests. The constitutive model in the fictitious isotropic space is defined by the same yield function, plastic potential and integration algorithms developed for standard isotropic materials.

2.1.1 Constitutive equation

The constitutive equation derives from the first and second laws of thermodynamics, the expression of the Helmholtz free energy, the additive decomposition of the strain tensor into elastic and plastic part and the Clausius-Duhem inequality. The latter is written as

$$\Xi = \left[\boldsymbol{\sigma} - m \frac{\partial \psi}{\partial \boldsymbol{\varepsilon}^e} \right] : \dot{\boldsymbol{\varepsilon}}^e - m \dot{\theta} \left[\frac{\partial \psi}{\partial \theta} - \eta \right] + \boldsymbol{\sigma} : \dot{\boldsymbol{\varepsilon}}^p - m \frac{\partial \psi}{\partial \boldsymbol{\alpha}} \dot{\boldsymbol{\alpha}} - \frac{1}{\theta} \mathbf{q} \cdot \nabla \theta \geq 0 \quad (1)$$

where Ξ is the dissipation, $\boldsymbol{\sigma}$ is the Cauchy stress tensor, $\psi = \frac{1}{2m} \boldsymbol{\varepsilon} : \mathbf{C} : \boldsymbol{\varepsilon}$ is the free energy function, $\dot{\boldsymbol{\varepsilon}}$ is the rate of change of the strain, m is the density, η is the specific entropy, θ is the temperature, $\boldsymbol{\alpha}$ is a set of internal variables and \mathbf{q} is the conductivity heat flow. Applying Coleman method on eq. (1) (Malvern, 1969) (Lubliner, 1990) the constitutive equation in the real space is obtained by

$$\boldsymbol{\sigma} = m \frac{\partial \psi}{\partial \boldsymbol{\varepsilon}^e} = \mathbf{C} : \boldsymbol{\varepsilon} \quad (2)$$

where \mathbf{C} is the four rank constitutive tensor.

The constitutive equation of the fictitious isotropic material is obtained considering the uniqueness of dissipation in the isotropic and anisotropic spaces (Car et al., 1999). Applying Coleman method the constitutive equation in the fictitious isotropic space can be written as

$$\bar{\boldsymbol{\sigma}} = m \frac{\partial \bar{\psi}}{\partial \bar{\boldsymbol{\varepsilon}}^e} = \bar{\mathbf{C}} : \bar{\boldsymbol{\varepsilon}} \quad (3)$$

where $\bar{\mathbf{C}}$ is the four rank constitutive tensor and $\bar{\boldsymbol{\varepsilon}}$ is the strain in the fictitious space. From now on $(\bar{\cdot})$ will denote variables in the fictitious isotropic space.

2.1.2 Yield and plastic potential functions

The yield and plastic potential functions are defined in Cauchy stress space, i.e.

$$\text{Yield function } \phi^\sigma(\boldsymbol{\sigma}; \boldsymbol{\alpha}_\sigma^m) = 0 \quad (4)$$

$$\text{Potential function } g(\boldsymbol{\sigma}; \boldsymbol{\alpha}_\sigma^m) = K \quad (5)$$

where $\boldsymbol{\sigma}$ is the Cauchy stress tensor, ϕ^σ and g are the yield and plastic potential functions, and K is a constant.

2.1.3 Translation of stresses from the anisotropic to the isotropic space

The relationship between the anisotropic and isotropic stress spaces is based on the following linear transformation (See Figure 1)

$$\bar{\sigma}_{ij} = A_{ijkl}^\sigma \sigma_{kl} \quad (6)$$

where \mathbf{A}^σ is a four rank tensor which relates the stress tensors in the anisotropic and isotropic spaces and $\bar{\boldsymbol{\sigma}}$ and $\boldsymbol{\sigma}$ are the Cauchy stress tensor in the isotropic and anisotropic spaces respectively.

For the definition of the shape and properties of the tensorial operator it is necessary to take into account the symmetry of the Cauchy stress tensor in the anisotropic and isotropic spaces, therefore the four rank transformation tensor must satisfy the following symmetries:

$$A_{ijkl}^\sigma = A_{jikl}^\sigma = A_{jilk}^\sigma \quad (7)$$

The symmetry of the four rank transformation tensor is also necessary:

$$A_{ijkl}^\sigma = A_{klij}^\sigma \quad (8)$$

The four rank transformation tensor \mathbf{A}^σ is obtained in global axis from the definition of the tensor components in local axes, through the following transformation

$$A_{ijkl}^\sigma = R_{ijrs} (A_{rspq}^\sigma)_{loc} R_{pqkl} \quad (9)$$

The four rank rotation tensor \mathbf{R} is defined as:

$$R_{ijkl} = r_{ik} r_{jl} \quad (10)$$

where $r_{ik} = \cos \left[(\vec{e}_i)_{glob}, (\vec{e}_k)_{loc} \right]$, \vec{e}_i is the unit vector corresponding to the k^{th} component of the global reference coordinate system chosen. The rotation tensor \mathbf{R} takes into account the angles between the local principal directions of the anisotropic material and those of the global coordinate system.

The components of \mathbf{A}^σ in the local coordinate system are defined as

$$\begin{aligned} (A_{1111}^\sigma)_{loc} &= R(0) & (A_{2222}^\sigma)_{loc} &= R(90) \\ (A_{1212}^\sigma)_{loc} &= (A_{2121}^\sigma)_{loc} = (A_{2112}^\sigma)_{loc} &= R(45) \end{aligned} \quad (11)$$

where $R(0) = \frac{\bar{f}_{11}}{f_{11}}$ is the ratio between the strength of the material in the fictitious isotropic and real anisotropic spaces in the local x axis direction, $R(90) = \frac{\bar{f}_{22}}{f_{22}}$ is the ratio between the strength of the material in the isotropic and anisotropic spaces in the local y axis direction and $R(45) = \frac{\bar{f}_{12}}{f_{12}}$ is the ratio between the shear strengths of the material in the fictitious and real spaces. It is important to note that the parameters which define \mathbf{A}^σ can be obtained from simple experimental tests.

The yield condition in both spaces is:

$$\phi(\boldsymbol{\sigma}; \boldsymbol{\alpha}) = \bar{\phi}(\bar{\boldsymbol{\sigma}}; \boldsymbol{\alpha}) = \bar{\phi}(\boldsymbol{\sigma}; \mathbf{A}^\sigma; \boldsymbol{\alpha}) = 0 \quad (12)$$

where ϕ and $\bar{\phi}$ are respectively the yield functions in the real anisotropic and the fictitious isotropic spaces.

2.1.4 Transformation of strains from the anisotropic to the isotropic space

The relationship between the elastic strains in the real anisotropic space and the fictitious isotropic space is given by:

$$\bar{\boldsymbol{\varepsilon}}_{ij}^e = A_{ijkl}^\varepsilon \boldsymbol{\varepsilon}_{kl}^e \quad (13)$$

where \mathbf{A}^ε is a four rank tensor, $\bar{\boldsymbol{\varepsilon}}$ and $\boldsymbol{\varepsilon}$ are the strain tensors in the isotropic and anisotropic spaces respectively. The hypothesis expressed by eq. (13) implies no uniqueness in the elastic strains between spaces. Tensor \mathbf{A}^ε is computed taking into account eqs.(36), (13) and the constitutive equation in the anisotropic and isotropic spaces (eqs.2 and 3) (Car et al., 1999). This gives

$$A_{mnr s}^\varepsilon = (\bar{C}_{mnij})^{-1} A_{ijkl}^\sigma C_{klrs} \quad (14)$$

where \bar{C}_{mnij} is the constitutive tensor in the fictitious isotropic space and C_{klrs} is the constitutive tensor in the real anisotropic space. Note that C_{klrs} includes the current properties of the material. The choice of \bar{C}_{mnij} can be arbitrary and for this purpose the property of any known material can be chosen.

The components of the are first defined in local axes and then transformed into global axes by the following expression

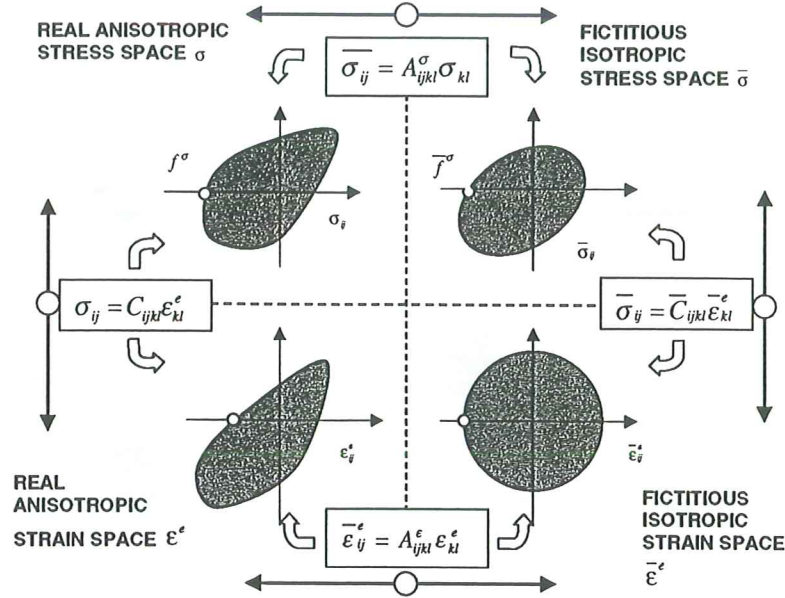

Figure 1: Space transformations. Real and fictitious stress and strain spaces in small strains

$$C_{ijkl} = R_{ijrs} (C_{rspq})_{loc} R_{pqkl} \quad (15)$$

where $(C_{rspq})_{loc}$ is the anisotropic constitutive tensor in the local coordinate system.

In Figure 1 the stress and strain spaces and the constitutive equation in both isotropic and anisotropic spaces are schematically shown. Recall that four rank tensors (A^σ) and (A^ϵ) establish the relationships between the variables in both spaces.

2.2 Definition of the elasto-plastic isotropic model in large strains

Kinematic changes is one of the most complex aspects to be considered when defining constitutive equations under large strain conditions. The kinematics used in this work are based on the multiplicative decomposition of the gradient

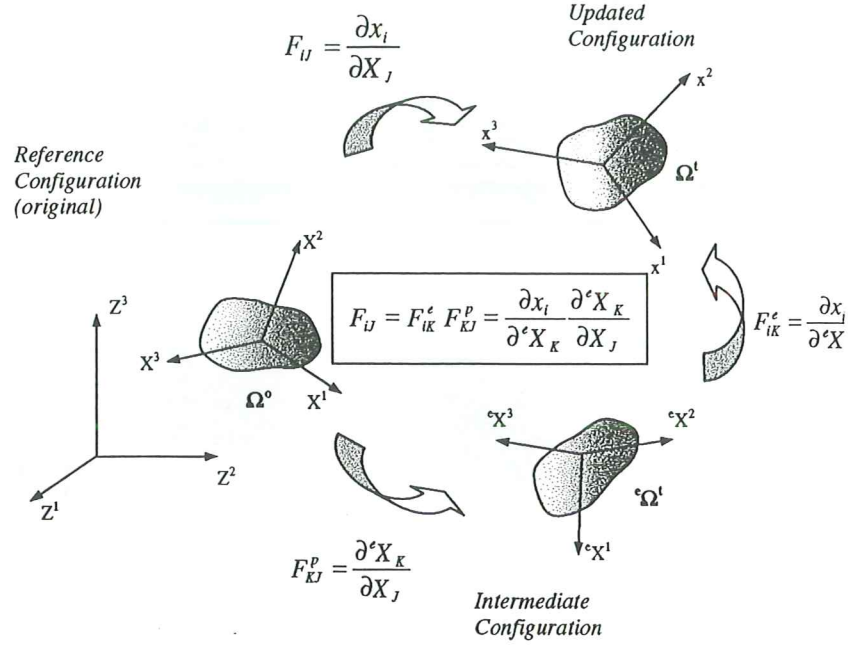

Figure 2: Original, intermediate and deformed configurations

deformation tensor introduced by Kroner (1960) and developed by Lee (1969) and Mandel (1971) .

The multiplicative decomposition results from the definition of the gradient tensor as

$$\mathbf{F} = \frac{\partial \mathbf{x}}{\partial \mathbf{X}} = \frac{\partial \mathbf{x}}{\partial \mathbf{X}^e} \cdot \frac{\partial \mathbf{X}^e}{\partial \mathbf{X}} = \mathbf{F}^e \cdot \mathbf{F}^p \quad (16)$$

where \mathbf{F}^e and \mathbf{F}^p are the elastic and plastic part of the gradient deformation. The elastic part of the deformation gradient is obtained by unloading the points of the deformed configuration up to the intermediate configuration $^e\Omega^t$.

In the kinematics of the elasto-plastic continuum under large strains three configurations are distinguished: original (${}^0\Omega$), intermediate (${}^e\Omega^t$) and deformed (${}^t\Omega$). The intermediate configuration is based on the coordinate system $\bar{\mathbf{X}}$. In Figure 2 the different configurations are shown.

2.2.1 Small elastic and large plastic strain case. Free energy expression

Composite materials are usually subjected to small elastic strains. Thus the elastic part of the deformation gradient \mathbf{F}^e tends to unity and the elastic part of the left Cauchy-Green tensor $(\mathbf{b}^e)^{-1}$ tends to the spatial metric tensor \mathbf{g} . In this case the distinction between intermediate and deformed configurations is irrelevant.

However, the plastic strains continue being finite and therefore it is necessary to keep the presence of the right Cauchy-Green tensor \mathbf{C} in the material expression of the constitutive model to preserve its physical meaning.

For the small elastic strain case it is enough to characterize the elastic component of the free energy by means of a quadratic function of the elastic part of Almansi strain tensor, i.e.

$$\psi^e = \frac{1}{2m} \mathbf{e}^e : \mathbf{c} : \mathbf{e}^e \quad (17)$$

where \mathbf{c} is the constitutive tensor on the updated configuration.

2.2.2 Constitutive equation

Taking into account the expression of dissipation on the updated configuration, the additive decomposition of the Almansi strains and the free energy expression (eq.17), the Kirchhoff stresses are obtained as:

$$\boldsymbol{\tau} = \mathbf{c} : \mathbf{e}^e = \mathbf{c} : (\mathbf{e} - \mathbf{e}^p) \quad (18)$$

In eq. (18) the constitutive tensor \mathbf{c} could be considered constant either on the updated or in the referential configuration. If it is considered constant in the reference configuration \mathbf{c} , is obtained by performing a "push forward" operation (García Garino, 1993) (Cante, 1995). Spatial variables are used in the definition of the constitutive equation because they describe in a natural way the physics of the problem. The afore-mentioned ideas do not preclude the possibility to formulate constitutive models in terms of material variables or using a reference configuration different from the deformed configuration. If the constitutive tensor is considered constant on the updated configuration, the constitutive tensor in the reference configuration comes out by performing a "pull back" operation. (García Garino, 1993) (Cante, 1995)

2.2.3 Yield condition

The yield condition distinguishes elastic and plastic behavior. All the stress states inside the domain limited by the yield function are considered elastic and those on the yield surface are considered plastic (Lubliner, 1990) (Crisfield, 1991). The yield condition depends on the material type. On the updated configuration it is defined as:

$$\phi(\boldsymbol{\tau}; \mathbf{g}; \alpha) = F(\boldsymbol{\tau}; \mathbf{g}) - k(\alpha) = 0 \quad (19)$$

where $\boldsymbol{\tau}$ is the Kirchhoff stress tensor, \mathbf{g} is the metric tensor on the updated configuration and α is the plastic internal variable which controls the evolution of the yield surface.

2.2.4 Flow rule

The flow rule defines the evolution of the plastic strains. On the updated configuration it is defined as:

$$L_v(\mathbf{e})^p = \mathbf{d}^p = \dot{\lambda} \frac{\partial g}{\partial \boldsymbol{\tau}} \quad (20)$$

where $g=g(\boldsymbol{\tau}; \mathbf{g})$ is the plastic potential function and $\dot{\lambda}$ is a non-negative scalar known as the plastic consistency parameter which satisfies the Kuhn-Tucker conditions (Lubliner, 1990) (Crisfield, 1991).

$$\dot{\lambda} \geq 0 \quad \phi(\boldsymbol{\tau}; \mathbf{g}; \alpha) \leq 0 \quad \dot{\lambda} \phi(\boldsymbol{\tau}; \mathbf{g}; \alpha) = 0 \quad (21)$$

2.2.5 Tangent elasto-plastic constitutive tensor

The tangent elasto-plastic constitutive tensor relates the Kirchhoff stress tensor and the Almansi strains by

$$L_v(\boldsymbol{\tau}) = \mathbf{c}^{ep} : L_v(\mathbf{e}) \quad (22)$$

The objective derivative of eq. (18) gives the rate constitutive equation

$$L_v(\boldsymbol{\tau}) = L_v(\mathbf{c}) : (\mathbf{e} - \mathbf{e}^p) + \mathbf{c} : [L_v(\mathbf{e}) - L_v(\mathbf{e}^p)] \quad (23)$$

2.2.6 Constitutive tensor constant on the updated configuration

As previously mentioned the constitutive tensor can be considered constant either on the referential or the updated configuration. This leads to the definition of different materials. If the constitutive tensor is considered constant on the updated configuration, the consistency condition comes out by taking into account the definition of the yield condition on the updated configuration (eq.(19)), i.e.

$$\dot{\phi} = \frac{\partial \phi}{\partial \boldsymbol{\tau}} : L_v(\boldsymbol{\tau}) + \frac{\partial \phi}{\partial \mathbf{g}} : L_v(\mathbf{g}) + \frac{\partial \phi}{\partial k} \frac{\partial k}{\partial \alpha} \dot{\alpha} = 0 \quad (24)$$

where $\dot{\alpha}$ is the rate of change of the internal variables defined by

$$\dot{\alpha} = \dot{\lambda} \left[\mathbf{h}_\kappa : \frac{\partial \mathbf{g}}{\partial \boldsymbol{\tau}} \right] = \mathbf{h}_\kappa : L_v(\mathbf{e}^p) \quad (25)$$

where the second order tensor \mathbf{h}_κ is a function of the stress state and of the hardening variable. In the most simple case of the incremental theory of plasticity \mathbf{h}_κ is the Kirchhoff stress tensor. The objective derivative of the spatial metric tensor is obtained by considering the relationship between the rates of change of the right Cauchy - Green tensor and the Green - Lagrange strain tensor, i.e.

$$\dot{\mathbf{C}} = 2 \dot{\mathbf{E}} \quad (26)$$

On the updated configuration this relation is written as:

$$L_v(\mathbf{g}) = 2L_v(\mathbf{e}) \quad (27)$$

Considering eqs.(20), (23), (24) and (27), the consistency equation can be rewritten as

$$\begin{aligned} \dot{\phi} &= \frac{\partial \phi}{\partial \boldsymbol{\tau}} : \left[L_v(\mathbf{c}) : (\mathbf{e} - \mathbf{e}^p) + \mathbf{c} : \left[L_v(\mathbf{e}) - \dot{\lambda} \frac{\partial \mathbf{g}}{\partial \boldsymbol{\tau}} \right] \right] + \\ &+ 2 \frac{\partial \phi}{\partial \mathbf{g}} : L_v(\mathbf{e}) - \frac{\partial k}{\partial \kappa} \dot{\lambda} \left[\mathbf{h}_\kappa : \frac{\partial \mathbf{g}}{\partial \boldsymbol{\tau}} \right] = 0 \end{aligned} \quad (28)$$

The product $L_v(\mathbf{c}) : (\mathbf{e} - \mathbf{e}^p)$ can be expressed as (Cante, 1995):

$$L_v(\mathbf{c}) : (\mathbf{e} - \mathbf{e}^p) = \mathbf{d} : L_v(\mathbf{e}) \quad (29)$$

where \mathbf{d} is given by :

$$d_{ijkl} = -4\bar{\mu} [e_{il}^e \delta_{jk} + \delta_{ik} e_{lj}^e] - 2\bar{\lambda} [\delta_{ij} e_{kl}^e + \delta_{ik} \delta_{jl} \text{tr} [e_{ij}^e]] \quad (30)$$

Taking into account eqs.(28), (29) and (30) the plastic consistency parameter is obtained as:

$$\dot{\lambda} = \frac{\frac{\partial \phi}{\partial \mathcal{T}} : (\mathbf{c} + \mathbf{d}) : L_v(\mathbf{e}) + 2\frac{\partial \phi}{\partial \mathbf{g}} : L_v(\mathbf{e})}{\frac{\partial \phi}{\partial \mathcal{T}} : \mathbf{c} : \frac{\partial \mathbf{g}}{\partial \mathcal{T}} - \frac{\partial k}{\partial \kappa} [\mathbf{h}_\kappa : \frac{\partial \mathbf{g}}{\partial \mathcal{T}}]} \quad (31)$$

The tangent elasto-plastic constitutive tensor is obtained from eq. (23), the plastic consistency parameter given by eq. (31) and the definition of the plastic flow (eq.(20)). This gives

$$L_v(\boldsymbol{\tau}) = \left[(\mathbf{c} + \mathbf{d}) - \frac{\left[\frac{\partial \phi}{\partial \mathcal{T}} : (\mathbf{c} + \mathbf{d}) + 2\frac{\partial \phi}{\partial \mathbf{g}} \right] \otimes \left(\mathbf{c} : \frac{\partial \mathbf{g}}{\partial \mathcal{T}} \right)}{\frac{\partial \phi}{\partial \mathcal{T}} : \mathbf{c} : \frac{\partial \mathbf{g}}{\partial \mathcal{T}} - \frac{\partial k}{\partial \kappa} [\mathbf{h}_\kappa : \frac{\partial \mathbf{g}}{\partial \mathcal{T}}]} \right] : L_v(\mathbf{e}) = \mathbf{c}^{ep} : L_v(\mathbf{e}) \quad (32)$$

where \mathbf{c}^{ep} is the tangent elasto-plastic constitutive tensor on the updated configuration.

2.2.7 Constitutive tensor constant in the reference configuration

The constitutive tensor can be considered constant in the reference configuration. In this case the first term of eq. (23) is zero, and the rate of change of the Kirchhoff stress is

$$L_v(\boldsymbol{\tau}) = \mathbf{c} : [L_v(\mathbf{e}) - L_v(\mathbf{e}^p)] \quad (33)$$

The plastic consistency parameter is obtained from the consistency equation (eq.. (24)), i.e.

$$\dot{\lambda} = \frac{\frac{\partial \phi}{\partial \mathcal{T}} : (\mathbf{c}) : L_v(\mathbf{e}) + 2\frac{\partial \phi}{\partial \mathbf{g}} : L_v(\mathbf{e})}{\frac{\partial \phi}{\partial \mathcal{T}} : \mathbf{c} : \frac{\partial \mathbf{g}}{\partial \mathcal{T}} - \frac{\partial k}{\partial \kappa} [\mathbf{h}_\kappa : \frac{\partial \mathbf{g}}{\partial \mathcal{T}}]} \quad (34)$$

The tangent elasto-plastic constitutive tensor is obtained from eq.(33), using the plastic consistency parameter given by eq.(34) and the definition of the plastic flow (eq. (20)). This gives

$$L_v(\boldsymbol{\tau}) = \left[\mathbf{c} - \frac{\left[\frac{\partial \phi}{\partial \mathcal{T}} : \mathbf{c} + 2\frac{\partial \phi}{\partial \mathbf{g}} \right] \otimes \left(\mathbf{c} : \frac{\partial \mathbf{g}}{\partial \mathcal{T}} \right)}{\frac{\partial \phi}{\partial \mathcal{T}} : \mathbf{c} : \frac{\partial \mathbf{g}}{\partial \mathcal{T}} - \frac{\partial k}{\partial \kappa} [\mathbf{h}_\kappa : \frac{\partial \mathbf{g}}{\partial \mathcal{T}}]} \right] : L_v(\mathbf{e}) = \mathbf{c}^{ep} : L_v(\mathbf{e}) \quad (35)$$

2.3 Extension of the anisotropic theory to large strain

2.3.1 Material formulation

To extend the elasto-plastic large strain model proposed to the anisotropic case is necessary to split the referential and updated configurations into the anisotropic and isotropic spaces, introduced in section 2 for the small strain case. Therefore, it is necessary to define the transformation tensors in the reference and updated configurations. The transformation of the second Piola Kirchhoff stress tensor in the anisotropic space to the isotropic space is performed in a similar way as presented in eq. (6), i. e.

$$\bar{S}_{IJ} = A_{IJKL}^S S_{KL} \quad (36)$$

where A^S is a four rank tensor which relates the stress tensors in the real and fictitious spaces, \bar{S} and S are the second Piola - Kirchhoff stress tensor in the fictitious isotropic and real anisotropic stress spaces respectively. The four rank tensor A^S is defined in the reference configuration and remains constant in this configuration. The definition of the elements of A^S is done in a similar way as for A^σ .

The global expression of A^S is obtained by standard transformation of the local components given by

$$A_{IJKL}^S = R_{IJRS} (A_{RSPQ}^S)_{loc} R_{PQKL} \quad (37)$$

where $(A_{RSPQ}^S)_{loc}$ is the four rank stress transformation tensor in the local coordinate system and R is a rotation matrix.

It is also necessary to define the relationship between the Green - Lagrange elastic strain in the real anisotropic space E_{IJ}^e and the Green - Lagrange elastic strain \bar{E}_{IJ}^e in the fictitious isotropic space. This relation is defined in the same way as presented in eq. (13); i.e.

$$\bar{E}_{IJ}^e = A_{IJKL}^E E_{KL}^e \quad (38)$$

where A^E is a four rank tensor which relates the Green - Lagrange strains in the anisotropic and isotropic spaces, \bar{E} and E are the Green - Lagrange strain tensors on the isotropic space and anisotropic space respectively. The four rank strain transformation tensor is computed taking into account eqs.(36) and (38) and it is equivalent to the expression given by eq.(14)

$$A_{MNRS}^E = (\bar{C}_{MNIJ})^{-1} A_{IJKL}^S C_{KLRs} \quad (39)$$

where \bar{C}_{MNIJ} is the constitutive tensor in the isotropic space and C_{KLSR} is the constitutive tensor in the real anisotropic space. The choice of \bar{C}_{MNIJ} can be arbitrary and for this purpose the properties of any known material can be chosen, because their influence in the computations is cancelled when all the quantities are returned to the real space.

The anisotropic constitutive tensor \mathbf{C} is defined in global axes by the following transformations

$$C_{IJKL} = R_{IJSR} (C_{RSPQ})_{loc} R_{PQKL} \quad (40)$$

where $(C_{RSPQ})_{loc}$ is the local four rank constitutive tensor in the anisotropic space in the local coordinate system and \mathbf{R} is a rotation matrix.

2.3.2 Formulation on the updated configuration

The relationship between the Kirchhoff stresses in the anisotropic and isotropic spaces on the updated configuration is given by

$$\bar{\tau}_{ij} = a_{ijkl}^{\tau} \tau_{kl} \quad (41)$$

where \mathbf{a}^{τ} is the four rank tensor which relates the stress tensor in the anisotropic and isotropic spaces on the updated configuration, $\bar{\tau}$ and τ are the Kirchhoff stress tensors in the isotropic and anisotropic spaces respectively.

In a large strain context, it is necessary to redefine the four rank transformation tensor on the updated configuration due to the fact that the four rank tensor \mathbf{a}^{τ} is not constant in this configuration and it is a function tensor \mathbf{A}^S in the referential configuration and the deformation gradient \mathbf{F} . Tensor \mathbf{a}^{τ} in the updated configuration is obtained by the "push - forward" operations (Car et al., 1999):

$$a_{ijkl}^{\tau} = F_{iI} (F^{-1})_{Kk} (F^{-T})_{lL} (F^T)_{Jj} A_{IJKL}^S \quad (42)$$

Similarly, the relation between Almansi strains in the anisotropic and isotropic spaces is defined by

$$\bar{e}_{ij} = a_{ijkl}^e e_{kl} \quad (43)$$

where tensor \mathbf{a}^e , establishes the relationship between the Almansi strain tensors in the anisotropic and isotropic spaces and \bar{e} and e are the Almansi strain tensors in the isotropic and anisotropic spaces respectively.

In an similar way \mathbf{a}^e on the updated configuration is obtained as:

$$a_{ijkl}^e = (F^{-T})_{iI} (F^T)_{Kk} F_{IL} (F^{-1})_{Jj} A_{IJKL}^E \quad (44)$$

In Figure 3 the four rank tensors which relate the stresses and strains spaces in the real and fictitious spaces in the referential (\mathbf{A}^S and \mathbf{A}^E) and updated (\mathbf{a}^τ and \mathbf{a}^e) configurations are shown.

2.3.3 Flow rule and evolution law for the internal variables

The evolution law of the plastic deformation on the updated configuration is given by:

$$L_v(\mathbf{e}^p) = \mathbf{d}^p = \dot{\lambda} \frac{\partial g}{\partial \boldsymbol{\tau}} \quad (45)$$

Taking into account that all the information on the material anisotropy is contained in the four rank transformation tensor \mathbf{a}^τ , the following plastic potential function on the fictitious space is proposed

$$g(\boldsymbol{\tau}; \mathbf{g}; \alpha) = \bar{g}(\boldsymbol{\tau}; \mathbf{a}^\tau; \mathbf{g}; \alpha) = \bar{g}(\bar{\boldsymbol{\tau}}; \mathbf{g}; \alpha) = k \quad (46)$$

Considering eqs. (46) and (45) the evolution of the plastic part of Almansi strain is

$$\mathbf{d}^p = \dot{\lambda} \frac{\partial g}{\partial \boldsymbol{\tau}} = \dot{\lambda} \frac{\partial \bar{g}}{\partial \bar{\boldsymbol{\tau}}} : \frac{\partial \bar{\boldsymbol{\tau}}}{\partial \boldsymbol{\tau}} = \dot{\lambda} \frac{\partial \bar{g}}{\partial \bar{\boldsymbol{\tau}}} : \mathbf{a}^\tau = (\dot{\bar{\boldsymbol{\epsilon}}})^\tau : \mathbf{a}^\tau \quad (47)$$

where $(\dot{\bar{\boldsymbol{\epsilon}}})^\tau$ is the plastic flow normal to the plastic potential function \bar{g} in the isotropic space. The additivity concept of the strain velocity allows to extend the strain transformation rule to the plastic part of the strains, so

$$\bar{\mathbf{d}}^p = \mathbf{a}^e : \mathbf{d}^p = \dot{\lambda} \mathbf{a}^e : \frac{\partial \bar{g}}{\partial \bar{\boldsymbol{\tau}}} : \mathbf{a}^\tau = \mathbf{a}^e : (\dot{\bar{\boldsymbol{\epsilon}}})^\tau : \mathbf{a}^\tau \quad (48)$$

where $\bar{\mathbf{d}}^p$ is the isotropic plastic strain on the updated configuration. The evolution of the plastic hardening internal variable is given by

$$\dot{\alpha} = \dot{\lambda} (\mathbf{h}^m)_\sigma : \frac{\partial g}{\partial \boldsymbol{\tau}} = \dot{\lambda} (\mathbf{h}^m)_\sigma : \frac{\partial \bar{g}}{\partial \bar{\boldsymbol{\tau}}} : \frac{\partial \bar{\boldsymbol{\tau}}}{\partial \boldsymbol{\tau}} = \dot{\lambda} (\mathbf{h}^m)_\sigma : \frac{\partial \bar{g}}{\partial \bar{\boldsymbol{\tau}}} : \mathbf{a}^\tau \quad (49)$$

where the second order tensor $(\mathbf{h}^m)_\sigma$ is a function of the actual stress state and of the actual hardening plastic variable. This tensor, in the most simple case of plasticity theory, is the stress tensor. Therefore, the evolution law of the internal variable is written as

$$\dot{\alpha} = \dot{\lambda} \bar{\boldsymbol{\tau}} : \frac{\partial \bar{g}}{\partial \bar{\boldsymbol{\tau}}} \quad (50)$$

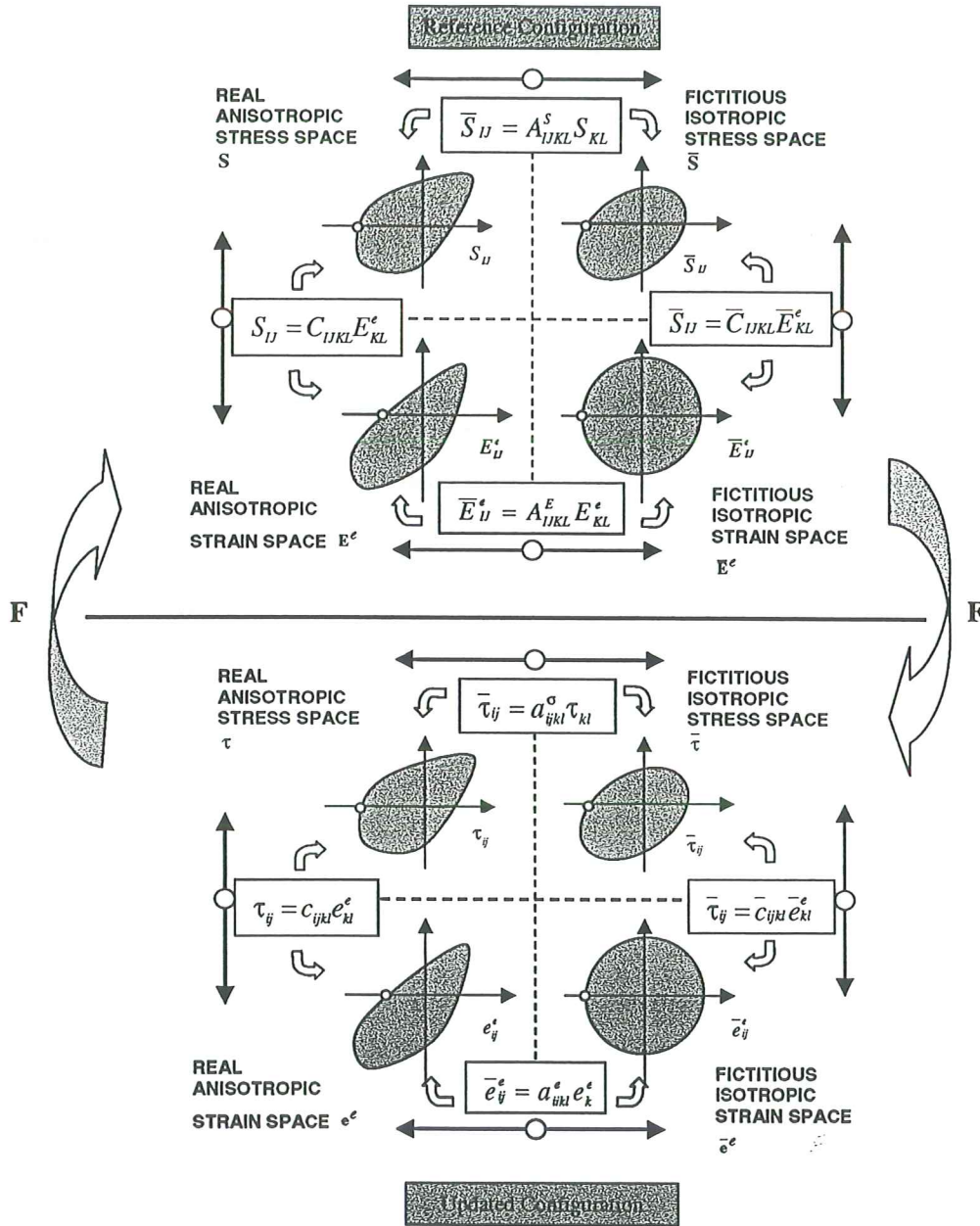

Figure 3: Extension of the anisotropic model to large strains. Spaces definition in reference and updated configurations.

3 Anisotropic composite material model

3.1 Introduction

The use of composite materials in structures like fiber reinforced plastic (FRP) has significantly increased during the past few years. This trend is mainly due to the fact that composite materials have properties which are very different from conventional isotropic engineering materials.

Composite materials present high strength to weight and high stiffness to weight ratio, are corrosion resistant, thermally stable and are well suited for structures in which the weight is a fundamental variable in the design process. Structural components requiring high stiffness and strength, impact resistance, complex shape and high volume production are suitable candidates to be manufactured using composite materials. This explains why aerospace, automotive and marine industries use these materials (Ali, 1996) (O'Rourke, 1989). Components manufactured with composite materials are tough and durable, exceeding in many occasions the performance of metal parts.

In the redesign process of a structural component using composite materials, simple replacement of the component is not enough. Due to the special characteristics of these materials (high anisotropy and high strength ratio between matrix and fibers), the redesign of the component is necessary. Furthermore, analytical techniques for components manufactured with composite materials are entirely different from conventional methods of analysis used for isotropic materials and require specialist knowledge. The design process of components made up of composite materials today is mainly based on empirical methods. The absence of numerical simulation tools for the non-linear analysis of the behavior of composite materials is observed in the literature.

The failure mechanism of fiber reinforced materials is complex due to the presence of diverse phenomena and can happen as a combination of diverse failure mechanisms. In this work the anisotropic constitutive model of previous section has been extended by using mixing theory to take into account this complex phenomena. Details of the particular class of mixing theory used are described next. The model is based on three theories:

- Large strains for isotropic materials,
- Mapping space theory for anisotropic materials. This theory allows to translate the anisotropic plastic behavior of the material into an isotropic plastic one.
- Enhanced mixing theory for isotropic materials which allows to combine basic substances,

The adequate selection of the constitutive model, yield criteria and plastic flow rule are very important in the description of the non-linear anisotropic behavior of FRP materials.

3.2 Mixing Theory

There are several theories which allow to simulate the constitutive behavior of composite materials, among them *Mixing Theory* is considered one of the most appropriate.

Trusdell and Toupin (1960) studied mixing theory providing the background for the work of Ortiz and Popov (1982a). These results also constitute the base of the work of Green and Naghdi (1965) and Ortiz and Popov (1982b) for bi-phase materials. The model presented here is a more general one and it allows to represent the non linear constitutive behavior of a material made up of "n" anisotropic phases undergoing large strains.

The mixing model chosen is based on the following assumptions: (i) in each infinitesimal volume of a composite material a finite number of compounding substances participate; (ii) each substance participates in the behavior of the composite in the same proportion that its volumetric participation; (iii) all compounds have the same strain (closing equation or compatibility concept); (iv) the volume occupied by each compound is much smaller than the total volume of the composite.

The second hypothesis implies a homogeneous distribution of all substances in a certain region of the composite. The interaction between the different compounding substances, each one with their own constitutive ("base") model, yields the behavior of the composite which depends on the percentage volume occupied by each substance and its distribution in the composite.

The third hypothesis is based on the fact that all phases in the mixture have the same strain field¹. The strain compatibility condition must be fulfilled in the reference and updated configurations for each phase. On the updated configuration the condition can be written as (Trusdell and Toupin, 1960) (Oñate et al., 1991):

$$e_{ij} \equiv (e_{ij})_1 = (e_{ij})_2 = \dots = (e_{ij})_n \quad (51a)$$

The definition of the stress τ of the whole composite is obtained considering an hyperelastic model (Malvern, 1969) as

¹This assumption is valid in absence of atomic diffusion. The atomic diffusion phenomena take place at high temperatures. In this analysis a moderate temperature below melting point is considered.

$$\boldsymbol{\tau} = m \frac{\partial \psi}{\partial \mathbf{e}} = \sum_{c=1}^n k_c m_c \frac{\partial \psi_c}{\partial \mathbf{e}} = \sum_{c=1}^n k_c (\boldsymbol{\tau})_c \quad (52)$$

where k_c is the ratio between the volume of the compounding c and the total volume of the whole composite. The elasto-plastic tangent constitutive tensor is obtained as (Car et al., 1999)

$$\mathbf{c}^T = \frac{\partial^2 \psi}{\partial \mathbf{e} \otimes \partial \mathbf{e}} = \sum_{c=1}^n k_c (\mathbf{c}^T)_c \quad (53)$$

where $(\mathbf{c}^T)_c$ is the tangent elasto-plastic real anisotropic constitutive tensor. Details of the derivation of the elastoplastic tensor are given in Oller et al., 1994.

Due to the presence of complex phenomena in the failure of composite materials the classical mixing theory is not enough, i.e. short fiber reinforced composite materials or debonding phenomena. This phenomena takes place in composite materials when there is a relative slip between compoundings and the maximum shear stress of the interface is greater than its yield value. In this case the matrix is not able to transfer the loads to the fiber, so the fiber can not increase its stress state because the matrix-fiber interface can not resist it. The modification in the constitutive model to take into account these phenomena is based on the ideas that the transfer of loads between matrix and fiber change when the matrix plastifies. This model is considered a "non-local material" model. It is based on defining the stress state in the fiber at the time the matrix reaches the plastic state. Then the fibers increase their stress state according to a new constitutive tensor which is a function of the frictional forces between matrix and fibers.

The classical mixing theory is valid only for materials with a parallel behavior, i.e. composite materials with large fibers. In the case of composite materials with short fibers the compatibility equation (eq.(51a)) is not valid. Therefore, in this case it is necessary to modify the compatibility equation (Oller et al., 1995b) or make a correction in the properties of each compound preserving the compatibility equation (Car et al., 1998). This method leads to a simpler formulation.

To take into account such phenomena, it is necessary to change the compatibility equation through the modification of the properties of the compounds. For short fiber composite materials, or composite materials with debonding phenomena the compatibility equation can be written as

$$e_{ij} \equiv \underbrace{n_1 (e_{ij}^e + e_{ij}^p)}_{(e'_{ij})_1} = \underbrace{n_2 (e_{ij}^e + e_{ij}^p)}_{(e'_{ij})_2} = \dots = \underbrace{n_n (e_{ij}^e + e_{ij}^p)}_{(e'_{ij})_n} \quad (54)$$

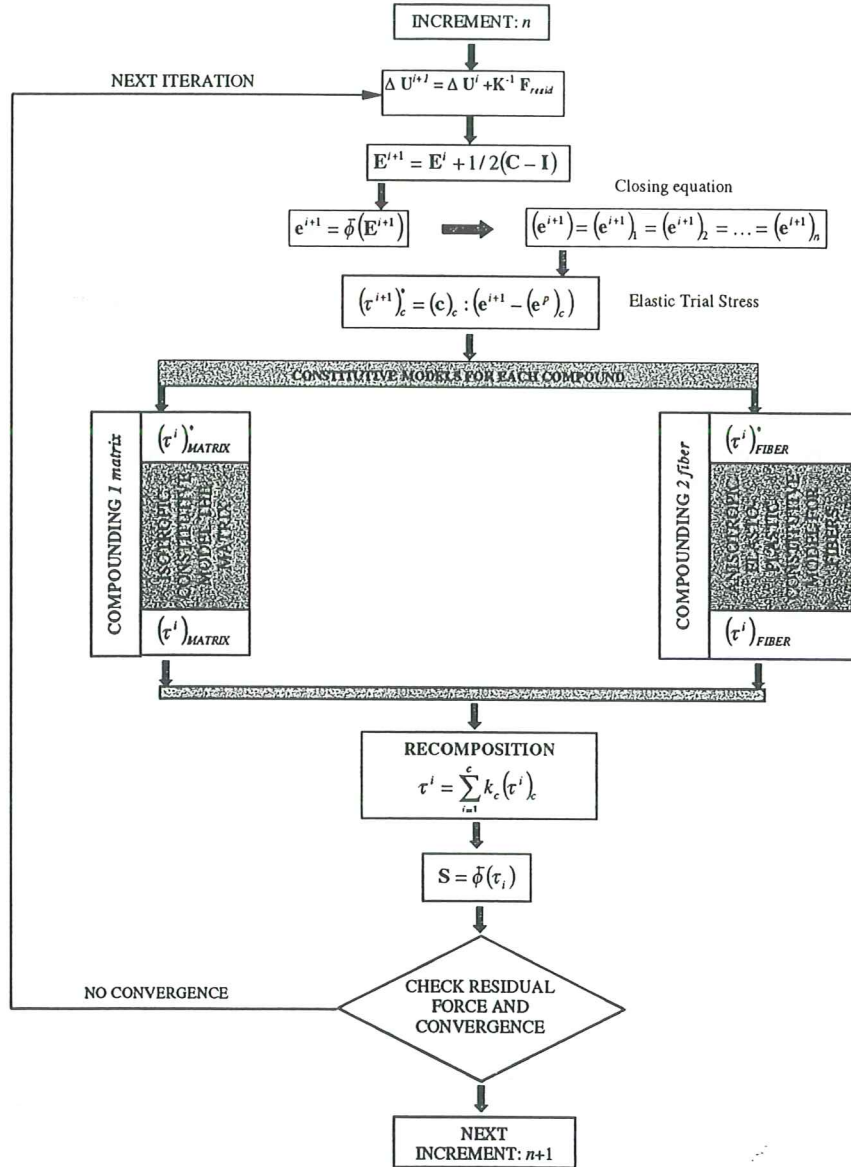

Figure 4: Constitutive model for bi-phase reinforced composite material

Eq. (54) expresses that the strains in each point and component e_i is n_i times the deformation of the whole material e . Factor n_i is a function of the internal strains variables. With this hypothesis, the stress in a compound is computed as

$$(\tau)_i = c_i : (e' - e^p)_i = \underbrace{n_i c_i}_{c'_i} : (e - e^p)_i \quad (55)$$

The proportionality factor n_i define a new constitutive tensor c'_i which allows to compute the stress of the i th compound in terms of the overall strains in the composite.

It is important to note that the elasto-plastic constitutive model presented in Section 2.3 is one of the "base" models used in the mixing theory above described.

In particular, in fiber reinforced composites a constitutive model for each phase is considered. A standard isotropic plasticity model has been chosen for the matrix material, whereas the behavior of the fiber reinforcement is modelled by the anisotropic elasto-plastic model proposed here.

Figure 4 shows a schematic flow diagram for the non-linear finite element analysis of a bi-phase material. The matrix phase is considered to be an isotropic material and the reinforcement fibers are modeled as an anisotropic material.

4 Numerical example. Shear test of a composite specimen

In this section, an application example using the proposed model is presented. The example consists of the study of the non linear behavior of a specimen made of a bidirectional laminated composite material $(+45^\circ, -45^\circ)_{SS}$ subjected to a plane shear state according to ASTM D4255 (American Society for Testing and Material, 1994). The matrix of the composite is a RS-3 Policinato resin and the reinforcement are carbon fibers XN-50 with volumetric participations of 40% and 60% respectively.

In the numerical simulation the resin behaves like an isotropic material with an elasto-plastic constitutive law, while the fibers behave as an anisotropic elasto-plastic material.

The mechanical properties of the epoxi resin and XN-50 fiber are given in Tables 1 and 2.

The dimensions of the specimen and the position on the testing machine are shown in Figure 5. Prescribed vertical displacements are considered on the test which induce a plane shear stress state.

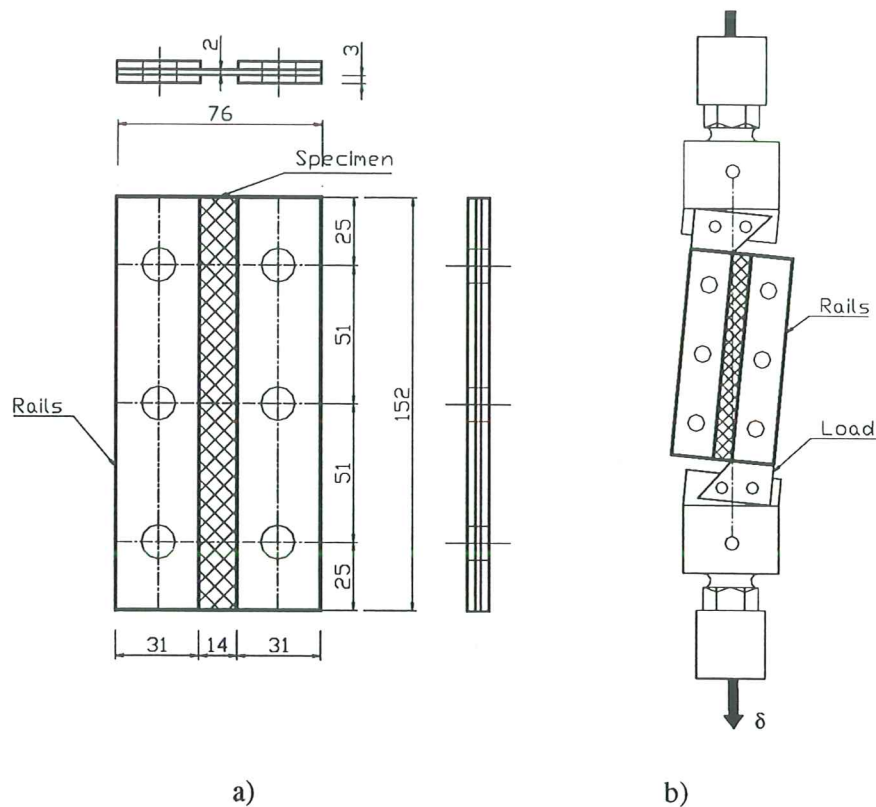

Figure 5: a) Geometry of the specimen b) Testing machine

The simulations have been carried out using a finite element mesh of standard 3 node plane stress triangular finite elements with 2074 elements, 1114 nodes and 2228 degrees of freedom. Figure 6 shows the finite element mesh used in the numerical simulations.

In Figure 7 the boundary conditions applied to the finite element mesh are shown. Figure 7a shows the detail of the boundary conditions of the left hand side holes in which a displacement in the vertical (y) direction is imposed. Figure 7b shows the boundary conditions in the right hand side holes where there are not imposed displacement. An incremental analysis considering 200 displacement increments was performed.

Figure 8 shows the deformation of the specimen in the final state. Displacements have been amplified three times to show the local effect produced on each hole. Deviation effects on deformed mesh during the development of the test can also be observed.

Young modulus	3170 <i>Mpa</i>
Poisson Coefficient	0,35
Yield Stress	75,53 <i>Mpa</i>
Post yield behavior law	exponential with softening
Fracture Energy	1,47 <i>N/m</i>
V_m	40%

Table 1: Material properties of epoxi resin

Young modulus	507.177 <i>Mpa</i>
Poisson Coefficient	0,0
Yield Stress	3183.34 <i>Mpa</i>
Post yield behavior law	linear with hardening
V_f	60%

Table 2: Material properties of XN-50 fiber

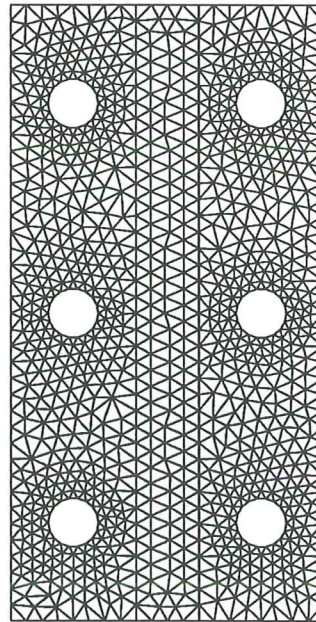

Figure 6: Finite element mesh

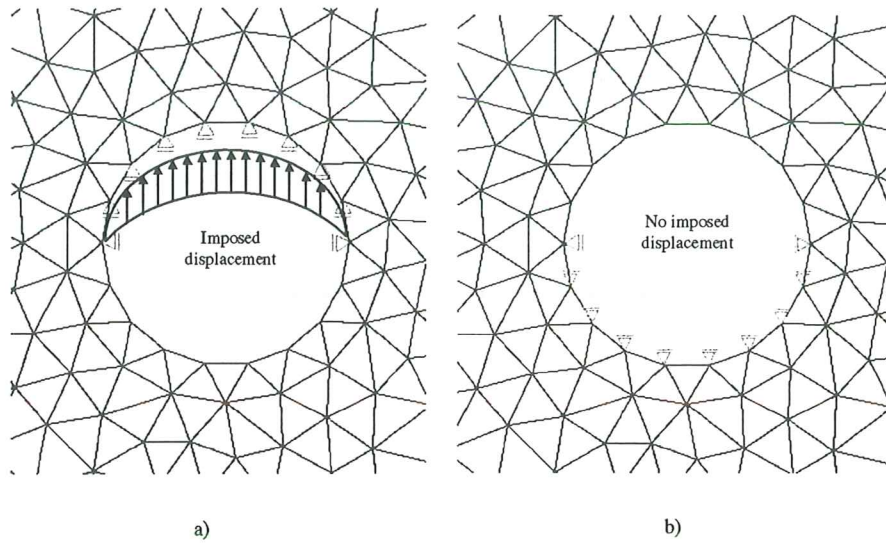

Figure 7: Boundary conditions used in the numerical simulation. a) Left holes. b) Right holes

In Figure 9 contours of the displacement module is presented. It is observed that in the central area of the specimen the displacement field presents a high gradient due to the relative displacements produced by the aluminium rails (See figure 5)

Contours of the σ_{xy} stress in the central area of the composite are plotted in Figure 10a. The maximum shear stress was reached in two zones of the central area. Figure 10b shows the plastic shear strains in the central area of the composite. Plastic shear strains are also concentrated in the center of the specimen. The irreversible plastic strain gives an idea of the diffuse fracture on the sample. (See Figure 11)

In Figure 11 the comparison between the tested specimen and the numerical simulation is displayed. In Figure 11a, the photograph of the tested specimen is shown. In the tested specimens two cracks can be observed with an angle of 45° with respect to the longitudinal axis of specimen. In the central area there is another crack. Figure 11 b shows the equivalent plastic strains contours obtained which indicate a diffuse fracture region (?) (Oller, 1991). The first fracture band appears in the central area of the specimen whereas two other fracture bands progress at 45° with respect to the longitudinal axis of the specimen. Figure 12a shows a detail of the cracks in the central area of the specimen and Figure 12b shows a detail of the first crack. In both figures it is possible to see

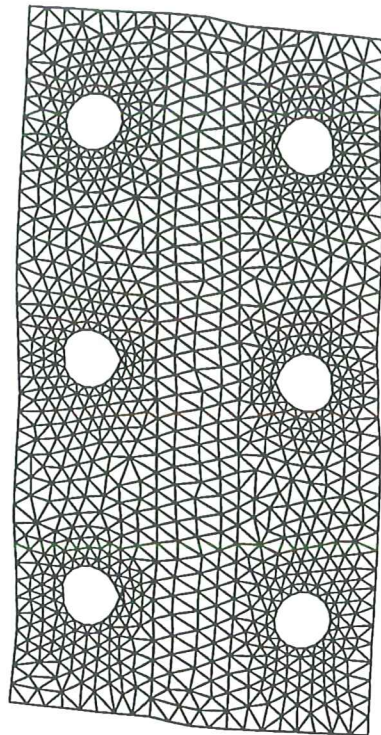

Figure 8: Shear test ASTM D4255. Deformation 3:1

the delamination phenomena taking place in the specimen. This is due to the presence in the composite of a high modulus phase: the fiber, and a low modulus phase: the matrix.

The curve in Figure 13 shows the total load vs. the displacement imposed at the left side holes. Results obtained with the mixing theory considering a linear behavior of each phase under small and large strains are compared with those obtained with the proposed non-linear model. Results using the small strain linear elastic model provide upper limit values. In this figure a non linear response of the composite is appreciated. One of the reasons of the non linear behavior of reinforced composite materials is due to the propagation of cracks in the matrix and the relative displacement between fibers and matrix. The phenomena of matrix cracking and debonding or slip between fibers and matrix reduces the global stiffness and leads to inelastic and not recoverable strains.

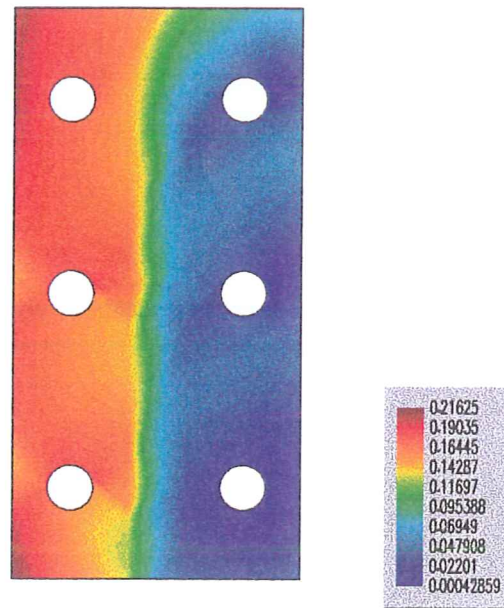

Figure 9: Test of Policinato RS-3 - XN-50 specimen. Contour of displacement

5 CONCLUDING REMARKS

The conventional techniques used for the analysis of simple isotropic materials are not valid for the non linear study of composites structures. It is therefore necessary to introduce new theories which account for the complex phenomena that take place in composite materials behavior.

An extension of the classic isotropic plasticity theory to multiphase anisotropic materials undergoing large strains has been presented. The anisotropic theory is based on the concept of mapped tensors from the real anisotropic space to a fictitious isotropic space. The use of an auxiliary fictitious isotropic space simplifies both the formulation of the non linear constitutive model and the computational implementation into standard non linear finite element codes.

Also in this work, and as an alternative to more standard composite models, the non linear behavior of composites is modelled by means of a modified mixing theory, acting on the anisotropic elasto-plastic model formulated in large strains developed in the paper.

The example presented shows that the constitutive model developed is appropriated for the analysis of composite materials in linear and non-linear regimes. The formulation is quite general and it allows to reproduce complex non linear phenomena in composite materials such as anisotropy, large strains, plasticity

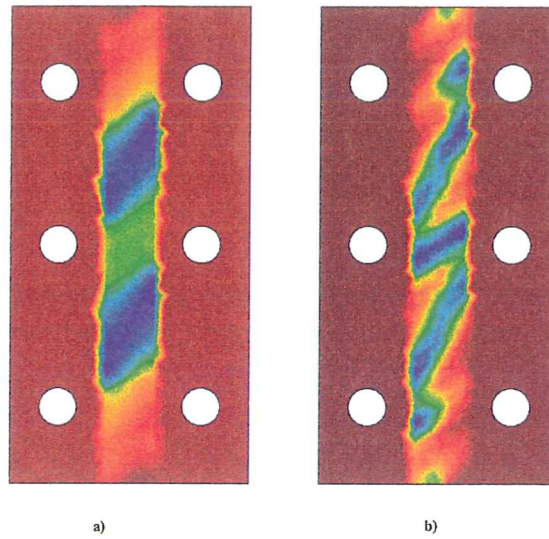

Figure 10: Test of Policinato RS-3 - XN-50 specimen. a) Contour of shear stress σ_{xy} b) Contour of plastic shear strains e^p

and fracture.

Acknowledgments

The authors wish to thank Construcciones Aeronáuticas S.A. (CASA) Space Division and specially to Mr. Pedro Luengo for providing the experimental data for the example presented. The authors gratefully acknowledge Prof. Maria A. Puigvi for her interest and helpful discussions. The first author also wants to thank the Generalitat of Catalunya for the financial support through the scholarship 1998TDOC00065.

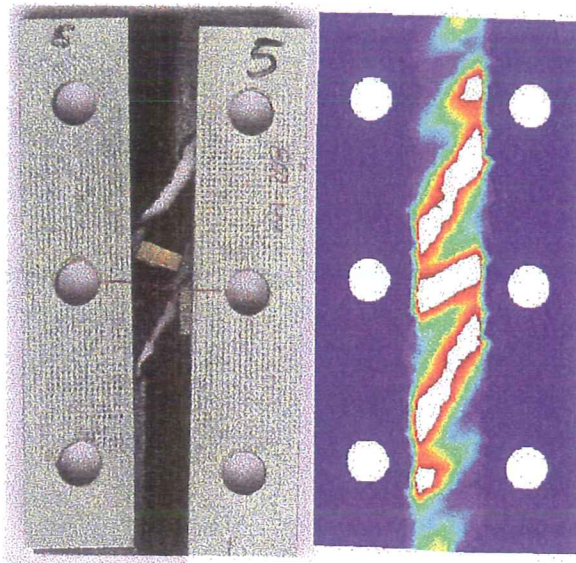

Figure 11: Test of Policinato RS-3 - XN-50 specimen. a) Photograph of tested specimen. b) Equivalent plastic strains contour

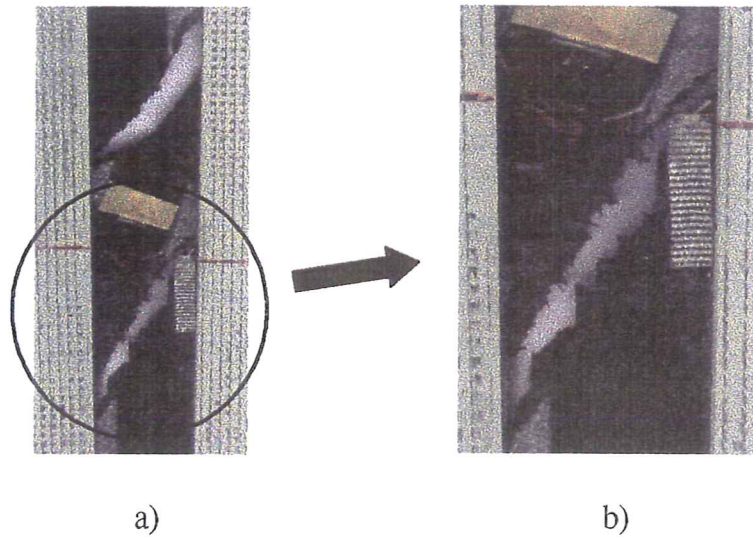
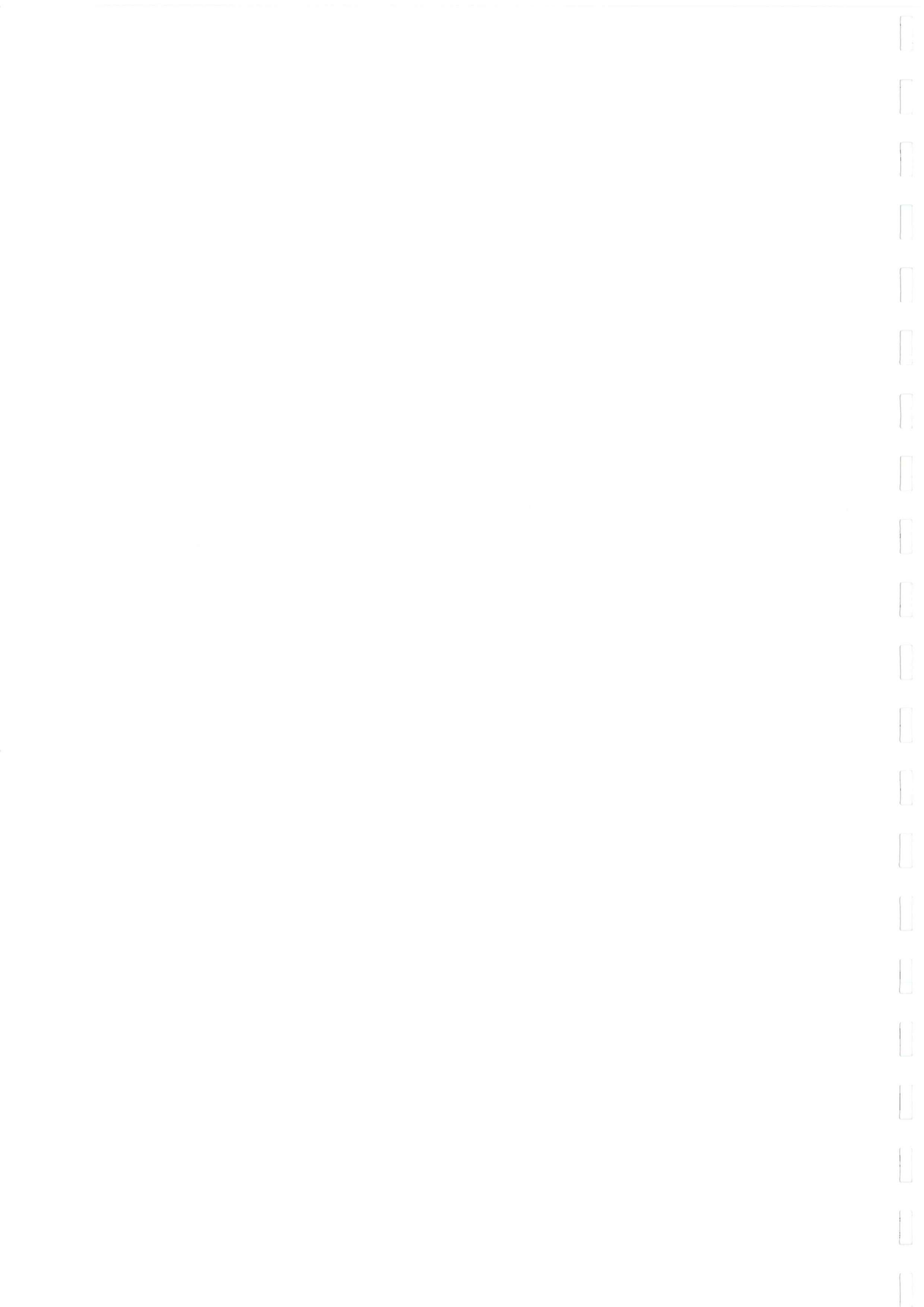

Figure 12: Test of Policinato RS-3 - XN-50 specimen. a) Detail of central area. b) Detail of a crack



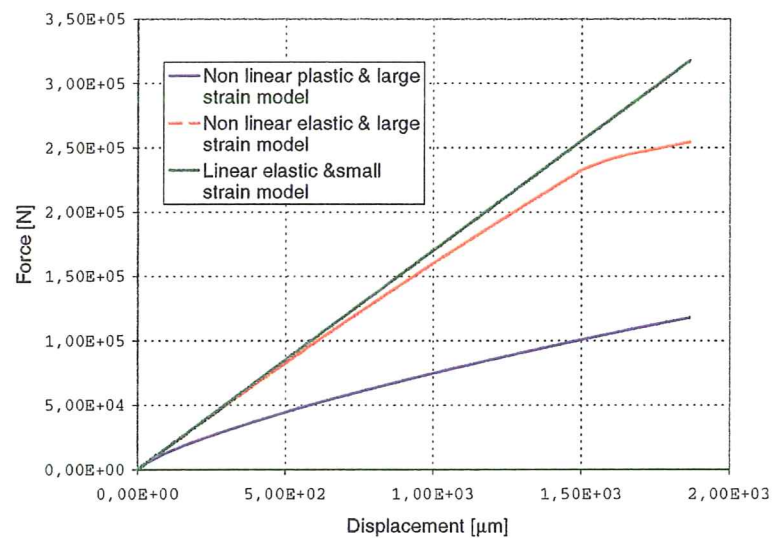
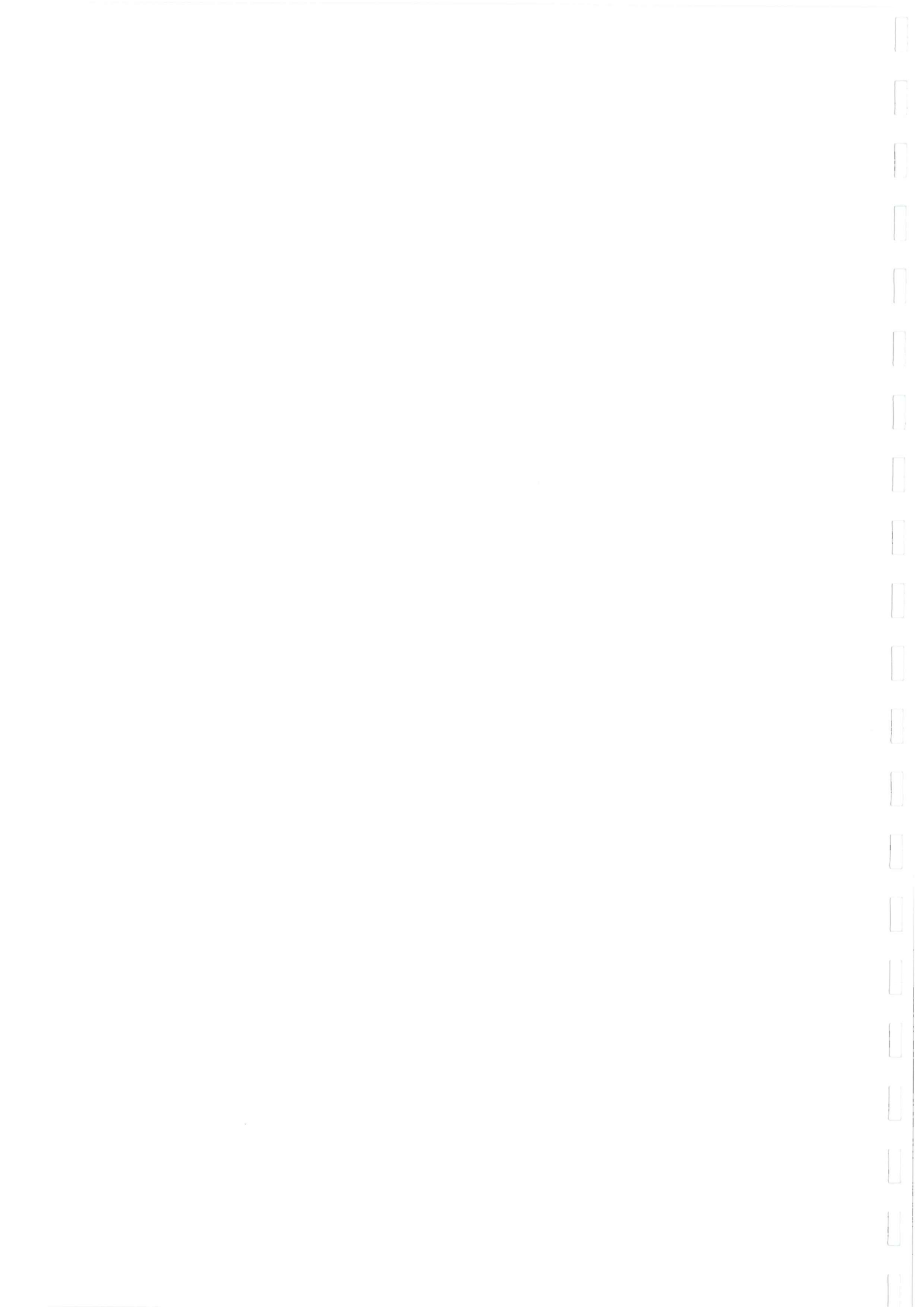

Figure 13: Test of Polycinato RS-3 - XN-50 specimen. Load - displacement plot



References

- Ali, R. (1996). Use of finite element technique for the analysis of composite structures. *Computers & Structures*, 58, No. 5:1015–1023.
- American Society for Testing and Material (1994). *ASTM Standards*. American Society for Testing and Materials, West Conshohocken, PA.
- Barlat, F., Lege, D. J., and Brem, J. C. (1991). A six-component yield function for anisotropic materials. *Int. J. Plasticity*, 7:693.
- Barlat, F. and Lian, J. (1989). Plastic behavior and stretchability of sheet metals. part i: A yield function for orthotropic sheet under plane stress conditions. *Int. Journal of Plasticity*, 5:51.
- Bassani, J. L. (1977). Yield characterization of metals with transversely isotropic plastic properties. *Int. J. Mech. Sci.*, 19:651.
- Bathe, K. J. (1982). *Finite Element Procedures in Engineering Analysis*. Prentice-Hall, Inc.
- Betten, J. (1981). Creep theory of anisotropic solids. *J. Rheol.*, 25:565–581.
- Betten, J. (1988). Application of tensor functions to the formulation of yield criteria for anisotropic materials. *International Journal of Plasticity*, 4:29–46.
- Budiansky, B. (1984). Anisotropic plasticity of plane-isotropic sheet. In Dvorak, G. J. and Shield, R. T., editors, *Mechanics of Material Behavior*, page 15, Amsterdam. Elsevier.
- Cante, J. C. (1995). *Simulación numérica de procesos de compactación de pulvimateriales. Aplicación de técnicas de cálculo paralelo*. PhD thesis, Universidad Politécnica de Cataluña.
- Car, E., Oller, S., and Oñate, E. (1998). Un modelo constitutivo elasto plástico acoplado con daño mecánico e higrométrico. Aplicación a pavimentos flexibles. *Revista Internacional de Ingeniería de Estructuras*, 3(1):19–37.
- Car, E., Oller, S., and Oñate, E. (1999). An anisotropic elastoplastic constitutive model for large strain analysis of fiber reinforced composite materials. *Accepted to be published in Computer Methods in Applied Mechanics and Engineering*.

- Crisfield, M. (1991). *Non-linear finite element analysis of solids and structures*. John Wiley & Sons Ltd.
- Dvorak, G. J. and Bahei-El-Din, Y. A. (1982). Plasticity analysis of fibrous composites. *Journal of Applied Mechanics*, 49:327 – 335.
- Eisenberg, M. A. and Yen, C. F. (1984). The anisotropic deformation of yield surfaces. *J. Engng. Mater. Technol.*, 106:355.
- García Garino, C. (1993). *Un modelo numérico para el análisis de sólidos elasto-plásticos sometidos a grandes deformaciones*. PhD thesis, Universitat Politècnica de Catalunya.
- Green, A. and Naghdi, P. (1965). A dynamical theory of interacting continua. *Journal Engineering Science*, 3:3–231.
- Gurtin, M. E. (1981). *An introduction to continuum mechanics*. Academic Press, New York.
- Hill, R. (1948). A theory of the yielding and plastic flow of anisotropic metals. *Proc. Roy. Soc. London. Ser. A.*, 193:281 – 297.
- Hill, R. (1971). *The Mathematical Theory of Plasticity*. Oxford University Press.
- Hill, R. (1979). Theoretical plasticity of textured aggregates. *Math. Proc. Cambridge Philos. Soc.*, 85(1):179 – 191.
- Hill, R. (1990). Constitutive modelling of orthotropic plasticity in sheet metals. *J. Mech. Phys. Solids*, 38(3):405 – 417.
- Hughes, T. (1987). *The Finite Element Method*. Prentice-Hall.
- Hull, D. (1987). *An Introduction to Composite Materials*. Cambridge University Press.
- Karafillis, A. P. and Boyce, M. C. (1993). A general anisotropic yield criterion using bounds and a transformation weighting tensor. *J. Mech. Phys. Solids*, 41(12):1859 – 1886.
- Kroner, E. (1960). Arch ratiō. *Mech. Anal*, 4:273.
- Lee, E. H. (1969). Elastic-plastic deformation at finite strains. *ASME Journal of Applied Mechanics*, 36:1–6.
- Lubliner, J. (1990). *Plasticity Theory*. Macmillan Publishing, U.S.A.

- Malvern, L. (1969). *Introduction to the Mechanics of a Continuous Medium*. Prentice-Hall.
- Mandel, J. (1971). *Plasticité classique et viscoplasticité. Cours au CISM Udine*. Springer Verlag.
- Matthews, F. L. and Rawlings, R. D. (1994). *Composite Materials: Engineering and Science*. Chapman and Hall.
- Oñate, E., Oller, S., Botello, S., and Canet, J. (1991). Methods for analysis of composite material structures (in spanish). Technical Report 11, CIMNE, Barcelona, Spain.
- Oller, S. (1991). Modelización numérica de materiales friccionales. Technical Report 3, C.I.M.N.E., Barcelona - Spain.
- Oller, S., Botello, S., Miquel, J., and Oñate, E. (1995a). An anisotropic elastoplastic model based on an isotropic formulation. *Engineering Computations*, 12:245–262.
- Oller, S., Neamtu, L., and Oñate, E. (1995b). Una generalización de la teoría de mezclas clásica para el tratamiento de compuestos en serie/paralelo. *Congreso Nacional de Materiales Compuestos*, pages 433–438.
- Oller, S., Oñate, E., and Miquel, J. (1993a). Simulation of anisotropic elastic-plastic behaviour of materials by means of an isotropic formulation. In *2nd. US Nat. Congr. Comput. Mech.*, Washington DC.
- Oller, S., Oñate, E., Miquel, J., and Botello, S. (1993b). A finite element model for analysis of multiphase composite materials. In Miravete, A., editor, *Ninth International Conferences on Composite Materials*, Zaragoza - Spain. Woodhead Publishing Limited.
- Oller, S., Oñate, E., Miquel, J., and Botello, S. (1996). A plastic damage constitutive model for composite materials. *Int. J. Solids and Structures*, 33(17):2501–2518.
- O'Rourke, B. P. (1989). The use of composite materials in the design and manufacture of formula 1 racing cars. *Proc. Inst. Mech. Engng.*, C387/025:39–48.
- Ortiz, M. and Popov, E. (1982a). A physical model for the inelasticity of concrete. *Proc. Roy. Soc. London*, A383:101–125.

- Ortiz, M. and Popov, E. (1982b). Plain concrete as a composite material. *Mechanics of Materials*, 1:139–150.
- Pendleton, R. and Tuttle, M. (1989). *Manual on Experimental Methods for Mechanical Testing of Composites*. Elsevier Applied Science Publishers.
- Shih, C. F. and Lee, D. (1978). Further developments in anisotropic plasticity. *J. Engng Mater. Technol.*, 105:242.
- Simo, J. C. and Hughes, T. (1998). *Computational Inelasticity*. Springer - Verlag.
- Trusdell, C. and Toupin, R. (1960). *The Classical Field Theories*. Handbuch der Physik III/I – Springer Verlag, Berlin.
- Voyiadjis, G. Z. and Foroozesh, M. (1990). Anisotropic distortional yield model. *J. Appl. Mech.*, 57:537.
- Voyiadjis, G. Z. and Thiagarajan, G. (1995). An anisotropic yield surface model for directionally reinforced metal matrix composites. *International Journal of Plasticity*, 11:867 – 894.
- Zienkiewicz, O. and Taylor, R. (1994). *El Método de Elementos Finitos Vol. 1 y 2*. Mc Graw Hill - Cimne.