

Modernist unreinforced masonry (URM) buildings of Barcelona. Seismic vulnerability and risk assessment

Gonzalez-Drigo R ¹, Avila-Haro JA ¹, Barbat AH ¹, Pujades LG ², Vargas YF ², Lagomarsino S ³ and Cattari S ³

¹ *Department of Strength of Materials and Structural Engineering. UPC-Barcelona-TECH. Barcelona, Spain.*

² *Department of Geotechnical Engineering and Geo-Sciences. UPC-Barcelona-TECH. Barcelona, Spain.*

³ *Department of Civil, Chemical and Environmental Engineering. University of Genoa. Genoa, Italy.*

Abstract

The main objective of this work is to assess the vulnerability and seismic risk of typical existing URM modernist buildings and aggregates situated in the Eixample district of Barcelona, part of the architectural heritage of the city. The context of the analysis is the methodology proposed by the Risk-UE project. The buildings are characterized by their capacity spectrum and the earthquake demand is defined by the 5% damped elastic response spectrum, considering deterministic and probabilistic earthquake scenarios. A discussion is made regarding the basis of the seismic damage states probabilities and the calculated damage index. An important research effort has been focused on the buildings modelling. All the architectural elements and their mechanical properties have been studied and evaluated accurately. It has been evidenced that a detailed and complete knowledge of all the structural elements existing in this type of buildings influence directly their behavior and hence the calculations and the results. The analysis of the isolated buildings and of the aggregate building has been performed for both mentioned seismic scenarios. Finally, a complete discussion of the results is included.

Keywords: Unreinforced masonry, modernist architecture, capacity spectrum method, vulnerability, fragility, risk assessment.

1 Introduction

In the Mediterranean area, modern cities accumulate a large number of buildings, infrastructures and facilities that result in an important concentration of socioeconomic value and in high population density. (EUROSTAT 2011; US Bureau of the Census 1991). At present the 75% of European people live in cities with more than 100,000 inhabitants.

The seismic hazard is not negligible in this area (Jiménez et al. 2001; Grünthal et al. 1999; Egozcue et al. 1991) and the seismic risk is higher than expected due to the high vulnerability of constructions built in the urban centres where a significant number of the current buildings are constructed with unreinforced brick masonry and without any consideration of the seismic actions. Most of these buildings are more than 100 years old, which means that they largely overpass the service life initially supposed for them. In addition, several circumstances, as the material degradation, some aggressive retrofitting and refurbishing works, and the changes in the

building load conditions, increased their overall vulnerability (Figure 1). Therefore, the vulnerability of these URM buildings, the important population density and the not negligible seismic hazard in the region, decisively increased the seismic risk in these urban areas.



Figure 1. Example of URM buildings with high seismic vulnerability. The addition of top levels to the original buildings increases even more their seismic vulnerability.

Recent studies in earthquake engineering are oriented to the development, validation and application of techniques to assess the seismic vulnerability of existing buildings. (Yépez et al. 1996; Barbat et al. 1998; Barbat et al. 2006a; Barbat et al. 2006b ; Carreño et al. 2007; Barbat et al. 2008; Lantada et al. 2009; Pujades et al. 2012)

Barcelona is a city located in a low-to-moderate seismicity region in the northeast of the Iberian Peninsula and in the western coast of the Mediterranean Sea. During the 19th century, a high population pressure and a city oppressed by the medieval walls were the determinant circumstances that generated a major urban expansion project. During the first period of this expansion, from 1860 to 1940, most of the buildings constructed were unreinforced masonry (URM) buildings. Today, many of those buildings, more than one hundred years old, still stand (Lantada 2007) and are part of the architectural heritage of Barcelona. The main objective of this work is to assess the seismic vulnerability and risk of those buildings, situated in the Eixample district of Barcelona by using the method proposed in the Risk-UE project (Milutinovic and Trendafiloski 2003). The structural analysis is performed by means of the TreMuri computer program (Lagomarsino et al. 2008) that has been specifically developed for the linear and nonlinear analysis of URM buildings. Different MATLAB codes (Matlab v.2009b The MathWorks) have been developed in order to obtain the fragility curves and the damage index

corresponding to each studied model. The most important results of this article are the fragility curves and the damage probability matrices obtained for this building typology.

2 The urban expansion project and the buildings

In 1850, Barcelona still remained as a walled city; in 1854 the decree for the urban expansion project was approved. The urban planning was designed in 1859 by the civil engineer Ildefons Cerdà. Thus, the mediaeval walls were demolished and the plain area between the city walls, the Mediterranean coast and the Collserola Hills was opened to be urbanized (Lantada 2007). The new district was called Eixample (enlargement). Figure 2 shows a typical section of the Eixample district.

Nowadays, the Eixample district has 247,418 inhabitants, a population density of 33,148 inhabitants/km² and 8,658 buildings. Most of these buildings were built before 1960, being 1931 the average year of construction. Today, the unreinforced brick masonry buildings suppose nearly 70% of the buildings of the Eixample (Lantada 2007).



Figure 2. A view of a section of the Eixample district (CCCB, 2009).

Although the buildings were built independently, most of them were constructed by sharing the lateral load walls with the existing adjacent buildings. In consequence, the masonry buildings of the Eixample district form large squared aggregates constituting the so called islands or blocks, following the urban framework shown in Figure 2. The framework of the urban plan is a net of squared blocks sided 133 m long on average. The streets, 25 m wide on average, cross orthogonally between the blocks. This framework makes buildings design conditional to the orthogonal shape of the blocks and the buildings can be fitted together if they are outlined following repetitive patterns. In the mid side of the blocks, central buildings have orthogonal perimeters with a ratio between the dimensions in plan of at least 2 to 1. At the end of the blocks, the corner buildings are more irregular and have a typical pentagonal perimeter. Figure 3 shows the floor plan of an actual and characteristic row of aggregate buildings, which includes the buildings analyzed in this study. In this figure, the names of the buildings studied in this article are also shown. In any case, even considering modern buildings, the shape in plane of the buildings does not depend on the building typology (unreinforced masonry or reinforced concrete), but it only depends on the geometrical fit of the building into the block aggregate.

2.1 The buildings

This study evaluated 3 existing isolated buildings and an aggregate of 2 buildings. All of them have 7 stories. The buildings correspond to a row aggregate of a block in a main street in the city of Barcelona. Figure 4 shows the façades of these buildings, which are very representative for the Eixample district; all of them are URM structures with load-bearing walls. Foundations are shallow, running through surface pads under the walls or, in case of more recent buildings, they are isolated foots under concrete pillars.

This discussion will refer to the rectangular buildings as M01, M02 and M03 (Figure 3). The aggregate corresponds to the sequence M01-M01. This means that the aggregate has been designed by means of two twin URM buildings built together. We will refer to this aggregate as A01. Figure 3 shows the existing aggregate. Other data relative to storey heights, walls density, loads and walls thicknesses are shown in Table 1, Table 2, Table 3 and Table 4.

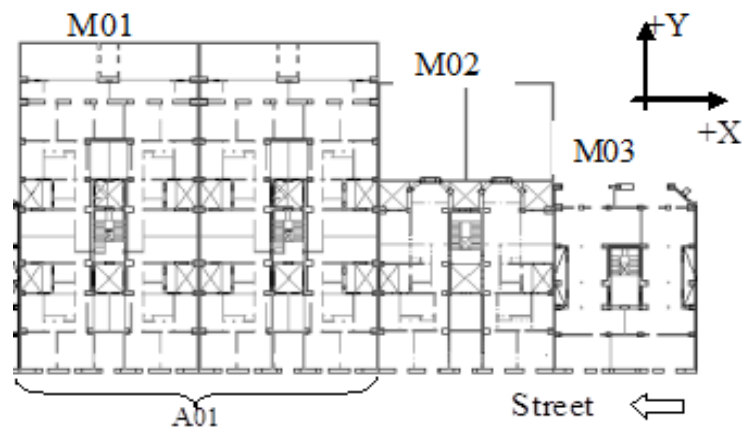

Figure 3. Floor plan of a characteristic row of aggregate buildings located in a main street of the Eixample district of Barcelona.



Figure 4. Façades of the analyzed buildings located in Barcelona.

The resistant elements are bearing walls and, in the ground floors, there may also exist masonry columns or cast iron columns. In general, these buildings only have the necessary elements to ensure the stability of the structure. More details of the specific architectonic features of the masonry buildings of the Eixample district are given by Paricio (2008).

TABLE 1
Geometric properties and load conditions of the isolated building M01

Properties		Storey						
		1	2	3	4	5	6	7
Storey Height (cm)		420	340	340	340	340	340	330
Walls density		0.089	0.059	0.059	0.059	0.059	0.059	0.059
Walls density	+X Dir	0.029	0.037	0.037	0.037	0.037	0.037	0.037
	+Y Dir	0.059	0.022	0.022	0.022	0.022	0.022	0.022
Dead load (daN)		350	350	350	350	350	350	350
Live load (daN)		200	200	200	200	200	200	100
Walls Thickness (cm)	Main façade	45	30	30	30	30	30	30
	Post facade	30	30	30	30	30	30	30
	Staircases	30	15	15	15	15	15	15
	Inner bearing walls		15	15	15	15	15	15
	Intermediate bearing walls	30	15	15	15	15	15	15
	Distribution walls		5	5	5	5	5	5

TABLE 2
Geometric properties and load conditions of the aggregate A01

Properties		Storey						
		1	2	3	4	5	6	7
Storey Height (cm)		420	340	340	340	340	340	330
Walls density		0.089	0.059	0.059	0.059	0.059	0.059	0.059
Walls density	+X Dir	0.029	0.037	0.037	0.037	0.037	0.037	0.037
	+Y Dir	0.041	0.022	0.022	0.022	0.022	0.022	0.022
Dead load (daN)		350	350	350	350	350	350	350
Live load (daN)		200	200	200	200	200	200	100
Walls Thickness (cm)	Main façade	45	30	30	30	30	30	30
	Post facade	30	30	30	30	30	30	30
	Staircases	30	15	15	15	15	15	15
	Inner bearing walls		15	15	15	15	15	15
	Intermediate bearing walls	30	30	30	30	30	30	30
	Distribution walls		5	5	5	5	5	5

TABLE 3
Geometric properties and load conditions of the isolated building M02

Properties		Storey						
		1	2	3	4	5	6	7
Storey Height (cm)		420	340	340	340	340	340	330
Walls density		0.107	0.062	0.062	0.062	0.062	0.062	0.062
Walls density	+X Dir	0.028	0.034	0.034	0.034	0.034	0.034	0.034
	+Y Dir	0.079	0.028	0.028	0.028	0.028	0.028	0.028
Dead load (daN)		350	350	350	350	350	350	350
Live load (daN)		200	200	200	200	200	200	100
Walls Thickness (cm)	Main façade	45	30	30	30	30	30	30
	Post facade	45	30	30	30	30	30	30
	Staircases	30	15	15	15	15	15	15
	Inner bearing walls	15	15	15	15	15	15	15
	Intermediate bearing walls	30	15	15	15	15	15	15
	Distribution walls		5	5	5	5	5	5

TABLE 4
Geometric properties and load conditions of the isolated building M03

Properties		Storey						
		1	2	3	4	5	6	7
Storey Height (cm)		420	340	340	340	340	340	330
Walls density		0.092	0.068	0.068	0.068	0.068	0.068	0.068
Walls density	+X Dir	0.034	0.035	0.035	0.035	0.035	0.035	0.035
	+Y Dir	0.058	0.033	0.033	0.033	0.033	0.033	0.033
Dead load (daN)		350	350	350	350	350	350	350
Live load (daN)		200	200	200	200	200	200	100
Walls Thickness (cm)	Main façade	45	30	30	30	30	30	30
	Post facade	45	30	30	30	30	30	30
	Staircases	30	15	15	15	15	15	15
	Inner bearing walls		15	15	15	15	15	15
	Intermediate bearing walls	30	15	15	15	15	15	15
	Distribution walls		5	5	5	5	5	5

2.2 The walls

The walls of the street façade, the inner courtyard of the block and the walls between buildings, usually called intermediate walls, are the main bearing walls. In the first storey, metallic columns (foundry columns in some buildings) and girders are present (Figure 5) and, usually, above those girders and for all the upper stories, additional bearing walls (usually two) are added parallel to the façades. This constructive solution, which avoids placing inner walls for the first or for the first two stories, is very common, permitting larger clear spaces, allowing the ground floors being used for trading or catering activities and for office or administrative activities in the mezzanines. In addition, each building has one or more nuclei around the

staircases and small internal courtyards made to provide natural light to the internal rooms. These nuclei are partially closed by masonry walls and are also used as bearing elements (Figure 6b). Finally these buildings also have a secondary system of interior walls which, in general, do not have a significant contribution to their strength; these walls have a thickness lower than 10 cm and their main function is to separate the volumes and to provide acoustic insulation.

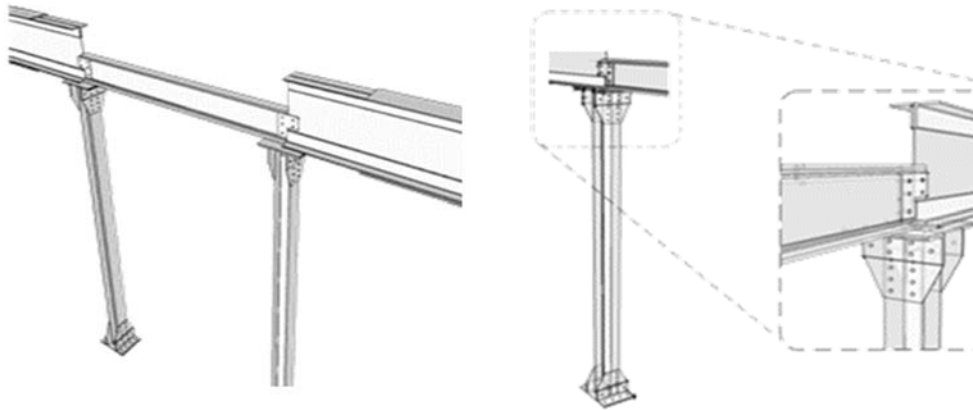

Figure 5. Metallic girders and iron columns at the base floor of the M01 building.

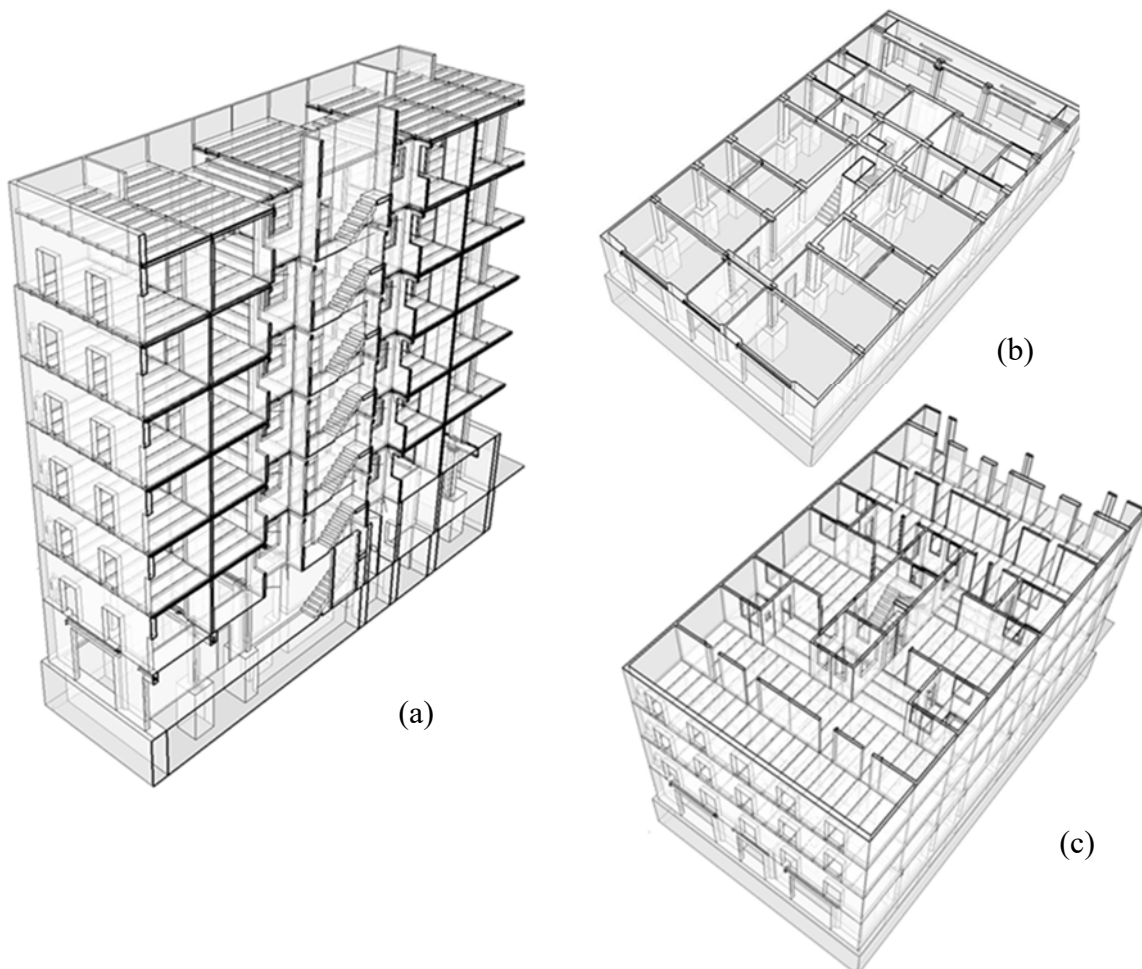

Figure 6. Cross sections of the isometric view of an isolated building (M01 in Figure 3). a) Half building. b) Base floor. c) Characteristic floor.

In general, the inner walls, which can reach lengths of up to 10 m, are poorly connected or connected neither to the façades nor to the walls between adjacent buildings and, therefore, they cannot behave as bracing walls. Furthermore, when there are openings for doors, windows or balconies, they have lintels or parapets of variable dimensions; the wall sections over lintels or parapets are extremely weak areas where cracks due to the effect of differential movements can be observed.

Both the street façade and the inner courtyard walls have significant openings with windows and balconies. As the level increases, these openings are smaller, so the presence of large openings is usual in the first levels, making these walls weaker even if their thickness is greater. Figure 6 shows a complete graphical description of one of the studied buildings (M01 in Figure 3). The intermediate walls shared between adjacent buildings are solid and do not present any opening. The first building raised up incorporates an intermediate wall with a thickness of 30 cm at the first floor. From the second level until the top of the building, the thickness of this wall diminishes to 15 cm. Over the entire height of the wall, some unreinforced masonry columns are embedded at a regular distance of 3.5 m to 5 m from each other. When the adjacent building is raised, it directly shares the intermediate wall of the first storey and it complements until 30cm the thickness of the wall at the upper floors. This means that in each building the maximum support of the floor beams is 15 cm on these walls (Figure 7). Details of the organization of these walls are shown in Figure 8.

An interesting geometric parameter is the density of walls which is defined as the ratio of the area of the cross section of all the walls of a specific storey to the total area of the floor (González 2010). For the analyzed buildings, Table 1, Table 2, Table 3 and Table 4 include the density of walls, the values of thickness corresponding to the different walls and the dead and live loads corresponding to different levels. For all the buildings, we took into account only the walls having a thickness greater than 10 cm. All the values are given for different stories.

2.3 The floors

From 1860 to 1960, most of the floors of the unreinforced buildings of the Eixample were solved with unidirectional slabs. But, at different periods, the materials of the elements used for the floors changed. From 1860 to 1890 approximately, the floors were one-way timber floors with single or overlapped wood planks including an additional concrete topping. From 1890 to 1940, iron beams and brick vaults were widely used. This is the case of the studied buildings (Figure 9 and Figure 10). After 1940, during the Spanish post-war period, there was a time of shortages when iron and steel were scarce. Therefore, the use of reinforced concrete beams and brick vaults or ceramic blocks was the solution for the floors.



Figure 7. Iron beams (sliced) simply supported on the wall.

The buildings studied in this article as typical for the URM building of the Eixample, were built between 1920 and 1935. Basically, their floors are composed of girder beams whose heads lay on bearing walls or on main beams. There are main beams only at the first level floor, sustained on cast iron columns (Figure 5 and Figure 6b), allowing large open spaces as described before. The support length of the girder beams on the perimeter walls depends on the wall thickness. For intermediate walls, the supporting length is 15 cm. In the case of façade walls, it is 30 cm for lower stories and 10-15cm for upper stories. This very common solution for the floors required girder beams with a separation ranging from 60 to 120 cm. The floor thickness is reduced, varying from 15 up to 20 cm, while the timber floors, older than these, have thicknesses that duplicate and even triplicate these values. Between the girder beams, the floor is solved by placing small vaults or, in more recent cases, case-bays. In all the cases, those elements spring on the girders flanges. In addition, the groins are filled with plaster and chippings and, then, the floor is smoothed, levelled and covered with the pavement (Figure 9 and 10). Due to their stiffness, the single bridging is not needed in these floors.

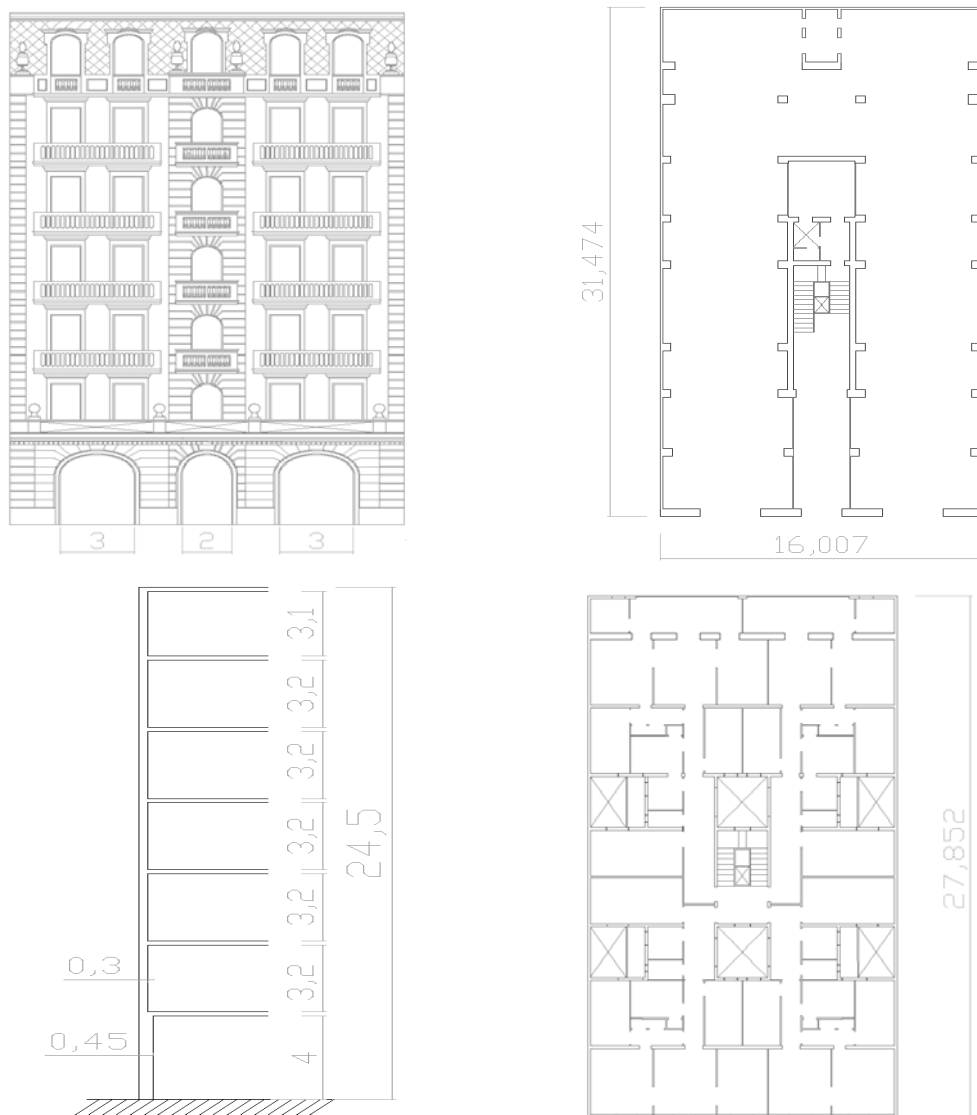

Figure 8. Architectural floor plans (building M01). a) Façade. b) Base floor. c) Side elevation. d) Intermediate floor [the dimensions are in m].

The total weight is due to the dead loads and the live loads. The load values used in this article are in accordance to the characteristic values from the city council regulations documents (Paricio 2008) previous to all the building codes that appeared and were currently in force after 1960 (Ministerio de la Vivienda 1963; 1988; Ministerio de Fomento 2006). For structural analyses, 200 kg/m^2 was assigned to the floor weight; the load due to the distribution walls has been estimated in 100 kg/m^2 ; the weight of an ordinary tiled floor pavement has been evaluated in 50 kg/m^2 and has to be added to the corresponding floor permanent load. In consequence, a permanent load of 350 kg/m^2 and a variable load of 200 kg/m^2 are the considered values in the calculations of the intermediate floors, while 350 kg/m^2 and 100 kg/m^2 are those considered for the terrace roofs.

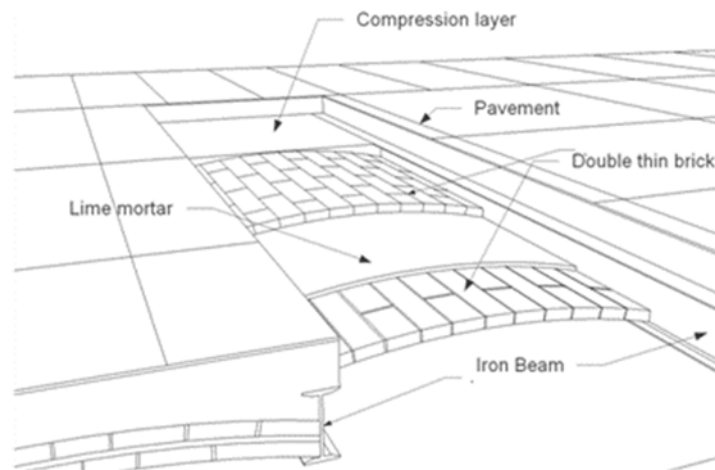

Figure 9. Floor system. Iron beams and brick vaults.



Figure 10. Details of a floor system observed during the demolition of an Eixample building.

2.4 The bricks and the mortars

The brickwork of the analyzed buildings uses solid prismatic bricks, made of fired clayey soils. These bricks are easy to handle and their thickness is lower than 12 cm. Ordinary bricks (29×14×5.5 cm) were mainly used in bearing walls; bricks of 4.5 (29×14×4.5 cm) were used in division walls; medium brick (29×14×3 cm) and thin bricks (29×14×2 cm) were used in the construction of vaults. According to the firing grade, there were four categories of bricks. As the firing grade increases, the strength and the apparent density of bricks and brickwork increase (Schindler and Bassegoda 1955). It was a common practice to select the most resistant bricks for very loaded walls. As the commercialization of ceramic hollow bricks started later, in 1940, they were not used in the analyzed buildings.

The studied buildings were built in the late 19th and early 20th centuries and most of their bricks were manufactured in continuous kilns; therefore they have similar properties. In general, they show a rough texture that favours a good adherence to the support. Their surface is rather compact without observable gaps like hollows and holes. Breakage of bricks shows a fine and regular grain and very few impurities of appreciable size in the matrix. There are not vitrified zones. The colour varies between red for the bricks with lower strength (7 MPa) and a more or less pale ochre for the higher strength ones (15 MPa). The strength demand conditioned the mortar selection for the brickwork. In order of decreasing strength, the mortars used were: Portland mortars, natural mortars (roman cement), lime mortars and bastard mortars.

2.5 The brickwork and the walls organization

In the buildings studied in this article, the different brickwork differs according to the wall function and its corresponding thickness (PIET 70 1971). The thickness of most of the partition walls was lower than 6.5 cm, without including the plastering. These walls are made of medium and thin solid bricks. In some cases, double partition walls are used, with a thickness between 6.5 and 9 cm without including the plastering. For all the bearing walls, the brickwork is made using solid bricks. Thus, the corresponding thickness is a multiple of the brick width (15 cm). Without taking account of plastering, the usual thicknesses are: 15 cm, 30 cm, 45 cm, 60 cm and 75 cm. The brickwork with ordinary brick in buried walls and in stairway cases is made with hydraulic lime mortar or with Portland mortar. The exterior brickwork is made with lime mortar. For medium range loads, the brickwork uses bastard mortar and, for main loads or in slender pillars, resistant bricks and Portland cement mortar are used.

Table 5 shows the values of the design strength of the brickwork made with solid bricks and different mortars. It should be considered that all the values are design values and that they have been obtained by reducing the corresponding characteristic values of strength with a coefficient of 2.5.



Figure 11. Example of distribution of the arches above openings.



Figure 12. Support length for the beams located above openings.

2.6 Openings and lintels

In the URM buildings of the Eixample, the doorways and window spans use discharging arches or iron lintels (Figure 11). For openings in thin walls, as is the case of the distribution walls, the option was to use wood elements for the lintels of the doorways and windows. In big openings, the lintels are made with two, three or more beams, according to the wall thickness (one beam for each 15 cm of wall thickness), and are placed parallel to each other. The beams are fastened with bolts housed into iron tubes that maintain the beams at the required distance. The length of the beams support onto the walls can be taken as the edge length of the beam but, in any case, it is inferior to 20 cm (Figure 12).

TABLE 5
Design strength of brickwork masonry for solid clay bricks (PIET 70 1971)

Design element	Properties		Design strength of brickwork using mortar (MPa)					
	Mortar plasticity	Joint thickness (cm)	M-5	M-10	M-20	M-40	M-80	M-160
7	Low	>1.5	0.8	0.9	1.0	1.1	1.2	-
	Low Medium	1 to 1.5 >1.5	0.9	1.0	1.1	1.2	1.4	-
	Low Medium High	<1 1 to 1.5 >1.5	1.0	1.1	1.2	1.4	1.6	-
	Medium High	<1 1 to 1.5	1.1	1.2	1.4	1.6	1.8	-
	High	<1	1.2	1.4	1.6	1.8	2.0	-
	Low	>1.5						
15	Low Medium	1 to 1.5 >1.5	1.4	1.6	1.8	2.0	2.2	2.5
	Low Medium High	<1 1 to 1.5 >1.5	1.6	1.8	2.0	2.2	2.5	2.8
	Medium High	<1 1 to 1.5	1.8	2.0	2.2	2.5	2.8	3.2
	High	<1	2.0	2.2	2.5	2.8	3.2	3.6
	Low	>1.5						
	Low Medium	1 to 1.5 >1.5	2.2	2.5	2.8	3.2	3.6	4.0
30	Low Medium High	<1 1 to 1.5 >1.5	2.5	2.8	3.2	3.6	4.0	4.5
	Medium High	<1 1 to 1.5	2.8	3.2	3.6	4.0	4.5	5.0
	High	<1	3.2	3.6	4.0	4.5	5.0	5.6

(Reproduced by permission of the Instituto Eduardo Torroja. Madrid, Spain.)

3 The structural analysis

TreMuri is a widely recognized and widespread computer program for the analysis of masonry structures. It was developed at the University of Genoa (Lagomarsino et al. 2008) in order to simulate the non-linear behavior of masonry structures. Its advanced, innovative computational model uses macroelements and constitutive laws based on experimental tests (Galasco et al. 2006; Calderini et al. 2009). For the analysis of masonry structures, this program, by means of the effective macroelement approach, adopts an accurate modeling strategy but without heavy computational load. The macroelement shear model (Gamberotta and Lagomarsino 1997) is a macroscopic representation of a continuous model in which the parameters are directly related to the mechanical properties of the masonry elements. Complete 3D models of URM structures can be obtained by assembling 2-nodes macroelements, representing the non-linear behavior of masonry panels and piers. This modeling strategy has been implemented in the TreMuri program with non-linear static and dynamic analysis procedures. By means of internal variables, the macroelement takes into account both the shear-sliding damage failure mode and its evolution, controlling the strength and stiffness degradation and rocking mechanisms with toe crushing effect. URM building models can be obtained by assembling plane structures, walls and floors. The program allows performing non-linear static and dynamic analyses of masonry structures using a well-defined seismic action. These characteristics distinguish TreMuri from other computer programs which mostly focus on reinforced concrete and steel structures.

The buildings studied in this article are made of solid clay ceramic bricks. They have regular floors in plan and a homogeneous distribution of the openings of the walls, excepting the first floor. These features assure their adequate modelling by using macroelements of the TreMuri computer program.

The buildings analyzed in this study were modeled on the basis of original floor plans and architectural drawings as well as other useful documents which supplied a selection of profitable technical data. Several manuals and books were used (Schindler and Bassegoda 1955). Other data were completed with existing laboratory tests results or have been obtained on the basis of technical reports of restoration of URM buildings of Barcelona and based on the guidelines and judgment of architects and civil engineers. The analyses are performed in order to obtain the seismic behavior of isolated buildings as well as of aggregated buildings.

The mechanical properties used in this study have been obtained on the basis of recent technical reports, results of existing mechanical tests results and values included in documents that are contemporary with the analyzed buildings. The guidelines and judgment of architects and civil engineers with expertise on these types of materials and constructions have also been taken into account. The main properties of the masonry walls and columns are: average specific weight, $\rho=18 \text{ kN/m}^3$, average elastic modulus $E=2650 \text{ MPa}$, average shear modulus, $G=589 \text{ MPa}$, average shear strength $\tau=7.95 \times 10^{-2} \text{ MPa}$, average compression strength $\sigma=2.65 \text{ MPa}$. Moreover, concerning the floors, an average total load (dead loads G + live loads Q) of 4.5 kN/m^2 for the last level, and 5.5 kN/m^2 for the rest of the levels, have been considered.

The modal analysis (Table 6) was performed for each building and the aggregate using the TreMuri software. From these analyses we can observe that the first and second modes of vibration are translational for the four structures, and that the third mode of each model is rotational.

TABLE 6
Modal analysis results for each building model

		Buildings			
		M01	A01	M02	M03
	Mode	Period T[s]	Period T[s]	Period T[s]	Period T[s]
Translation	1	0.548	0.571	0.688	0.668
Translation	2	0.537	0.544	0.562	0.521
Rotation	3	0.468	0.502	0.525	0.494

4. The earthquake scenarios

The seismic hazard can be evaluated using deterministic and probabilistic methods. The deterministic method assumes that the historical seismicity contains sufficient information to assess the seismic hazard of a certain region. On the other hand, the probabilistic approach evaluates the seismic hazard by linking a probability of occurrence to the tectonic and seismicity information of a specific region. For the City of Barcelona, the deterministic scenario was defined by the 1448 Cardedeu earthquake, which occurred at an epicentral distance of 25 km with a 7 km depth and an epicentral intensity of VIII (EMS'98) (Secanell et al. 2004). The probabilistic scenario was obtained based on the attenuation law of Ambrasseys et al. (1996) and on the regional parameters obtained by Secanell et al. (2004) with the software CRISIS-99.

For both scenarios, Irizarry (2004) fitted the analytical formulations proposed in Eurocode 8 and RISK-UE project (Milutinovic and Trendafiloski 2003), by varying the acceleration response spectra obtained for four different soil zones of Barcelona defined in previous studies by Cid (1998). The reliability of both approaches was evaluated by calculating the Root Mean Square and error percentage between each approach and the target spectrum obtained from the seismic hazard analysis. The RISK-UE approach was selected for the calculation of the 5 percent-damped demand spectra.

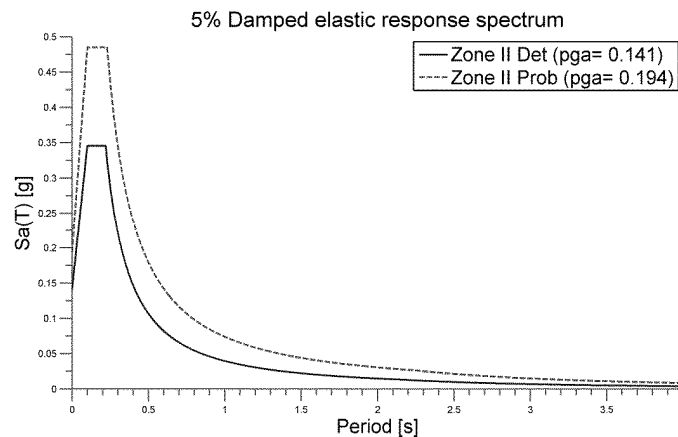

Figure 13. 5% damped elastic response spectra for the deterministic and probabilistic earthquake scenarios of Barcelona.

The seismic microzonation of the soils of Barcelona considers four seismic zones with different soil types; namely A, I, II and III (Cid 1998; Irizarry 2004). Soils in zone A correspond to rocky outcrops, soils in zone I correspond to very soft soils, typical of deltaic zones; in zone II, soils are intermediate soft soils and in zone III, soils are intermediate hard. Since the Eixample district is located mostly in zone II, this type of soils has been selected for the assessment of the expected damage. Figure 13 shows the 5% damped elastic response spectra corresponding to the deterministic and probabilistic earthquake scenarios.

5. The buildings damage states

The Eixample district where the analyzed buildings are located is placed in the soil zone II. The analyses performed to obtain the seismic behavior of these structures were made by using the response spectrum of this zone. The procedure followed for the capacity and fragility assessment is based on the capacity spectrum method, which provides a graphical representation of the capacity curve of the structure and compares it to the seismic demand spectra (ATC-40 1996).

According to the guidelines described in ATC-40 (1996), the capacity curves for each analyzed building are obtained by means of a pushover analysis. The capacity curves obtained in terms of base shear and roof displacement are converted to the Acceleration-Displacement Response Spectra (ADRS) format (ATC-40 1996). Figure 14 shows the capacity curves and the capacity spectra for the building A01 in the +X and +Y directions. Figure 15 and figure 16 show the capacity curves in ADRS format and for the +X and +Y directions, respectively, for the isolated building M01 and for the aggregate A01. Additionally, the demand spectra for the deterministic and probabilistic seismic scenarios are also included in ADRS format.

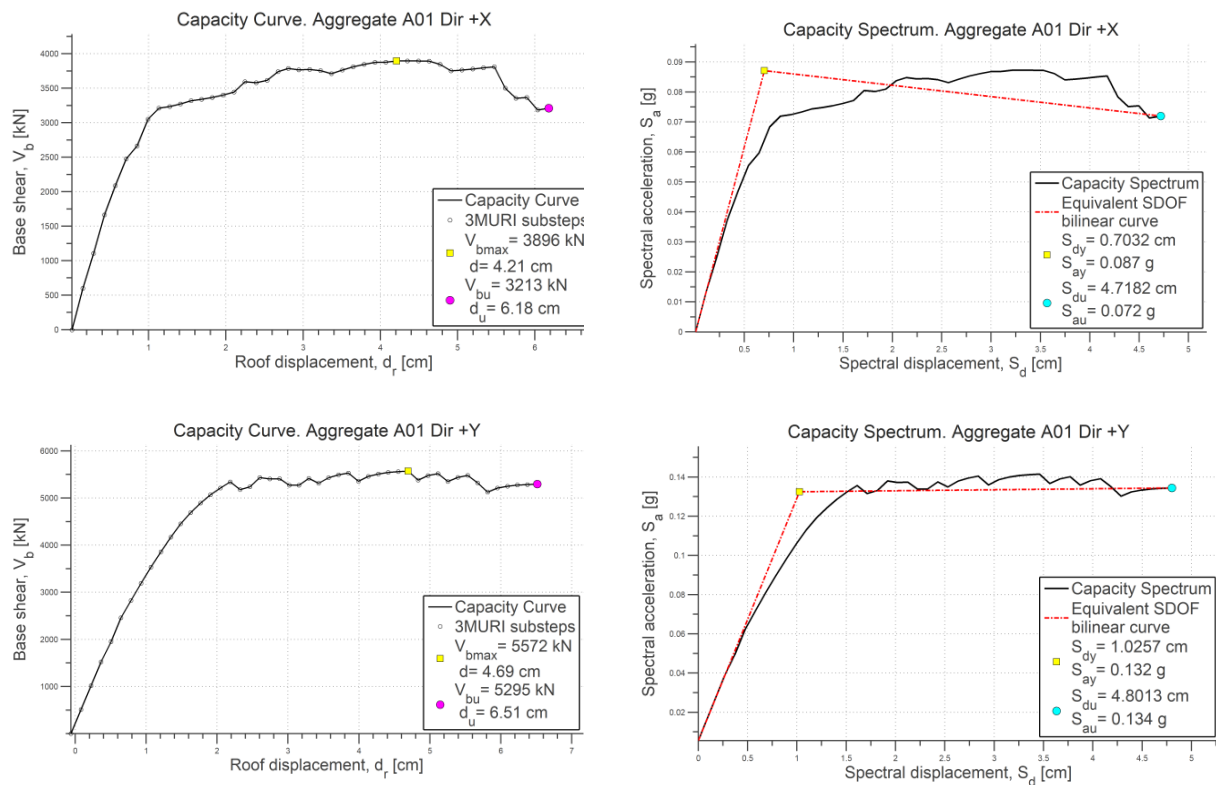

Figure 14. Capacity curves and capacity spectra in +X and +Y directions for the aggregate A01.

The response spectrum is converted from the standard Sa-T format to the ADRS format (ATC-40 1996). The next step of the analysis consists in developing fragility curves for each building model. This part of the analysis is performed according to the simplified procedure proposed in the RISK-UE project (Milutinovic and Trendafiloski 2003).

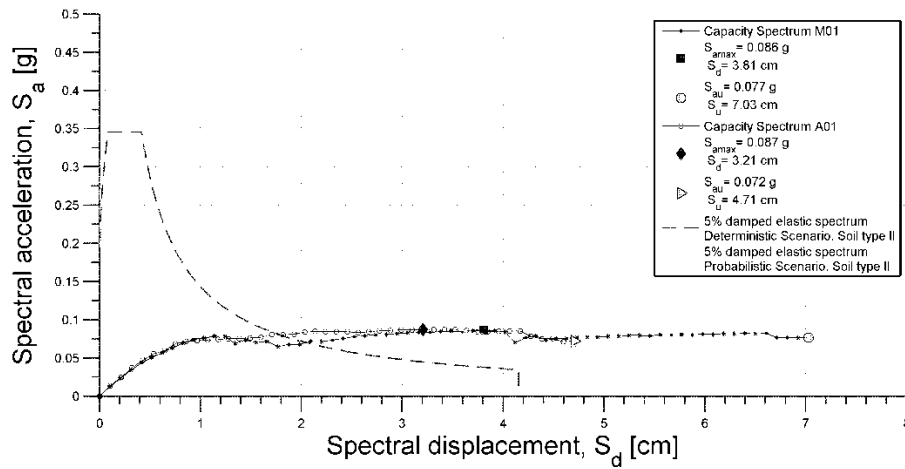

Figure 15. Capacity spectrum of building M01 and aggregate A01. Deterministic and probabilistic scenarios and direction +X.

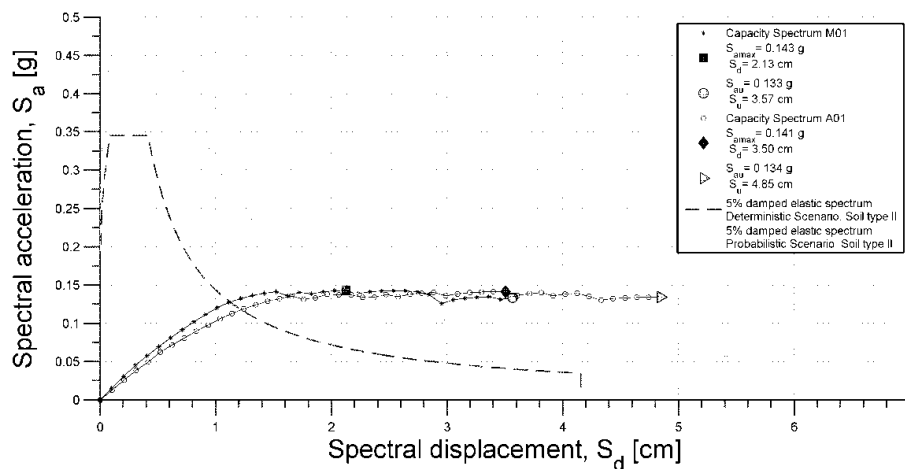

Figure 16. Capacity spectrum of building M01 and aggregate A01. Deterministic and probabilistic scenarios and direction +Y.

The assessment of the buildings damage requires the definition of different damage states in order to predict several types of losses due to structural damage. The number of damage states and the way used to define them vary from one guideline to another. For example, the methodologies exposed in HAZUS'99 (FEMA/NIBS 1999) and RISK-UE (Faccioli and Cauzzi 2006) define four damage states: Slight (ds_1), Moderate (ds_2), Severe (ds_3) and Complete (ds_4). The RISK-UE methodology was applied in this work, in which the damage states depend on the parameters of the bilinear representation of the capacity spectrum ($[Sd_y, Sa_y]$ and $[Sd_u, Sa_u]$) (Lagomarsino et al. 2002).

6. Fragility curves and damage indices

The probability of reaching or exceeding a given state of damage is represented by fragility curves. There are several available methods to develop fragility curves, albeit their refinement and quality depend on the field of application and their use. These methods can be classified in four main types: judgment-based (expert opinions), observational/empirical (experiments), analytical (models), and hybrid (two or more of the other methods). In the selection of one or another method, it is mandatory to take into account the available information, the level of knowledge of the failure modes, and the disposable resources. These curves are described by lognormal cumulative probability functions. Their main purpose focuses on expressing the degree of damage that a structure or a set of structures will experience when exposed to ground motion actions.

The need to express the degree of damage in terms of probability is due to the variation in response of the studied structures because of the large number of uncertainties related to aspects such as the action to which they are subjected, the use of generic information instead of specific data, the soil where they are located, as well as those uncertainties inherent to the structure and its modeling (e.g., material properties, structural type, use, regularity, symmetry).

The assumption of using lognormal distributions can be justified as prudent because of its adequacy for representing the statistical variation of many material properties and seismic response variables (Kennedy et al. 1980). For the purposes of this work, the spectral displacement will be used as the parameter that defines the seismic action. The probability of reaching or exceeding a defined damage state, ds_i , due to a spectral displacement, sd , is shown on Equation 1 (FEMA/NIBS 1999):

$$P[ds \geq ds_i | sd] = \Phi \left[\frac{\ln \left(\frac{sd}{sd_{ds_i}} \right)}{\beta_{ds_i}} \right] \quad (1)$$

where β_{ds_i} is the standard deviation of the natural logarithm of the spectral displacement at which the structure reaches the damage state ds_i , sd_{ds_i} , is the mean value of this spectral displacement, and Φ is the normal standard cumulative function.

For each damage state, the mean value of the corresponding fragility curve is obtained from the capacity spectrum using simplifying assumptions. Then, for obtaining the standard deviations, it is assumed that the probability of reaching or exceeding that particular damage state and this spectral displacement is 50% and that the seismic damage of the buildings follows a binomial probability distribution (Table 7) or an equivalent Beta distribution. A detailed explanation on how the fragility curves are obtained from the capacity spectra can be found in (Lantada et al. 2009). Figure 17 shows the fragility curves for the A01 building in the +X and +Y directions. Table 8 shows the mean values and the standard deviations of the fragility curves corresponding to the analyzed buildings and aggregate.

TABLE 7
Binomial probability distribution of the different damage states

	$P(ds_1)$	$P(ds_2)$	$P(ds_3)$	$P(ds_4)$
$P(ds_1)=0.5$	0.50	0.119	0.012	0.00
$P(ds_2)=0.5$	0.896	0.50	0.135	0.008
$P(ds_3)=0.5$	0.992	0.866	0.50	0.104
$P(ds_4)=0.5$	1	0.988	0.881	0.50

The procedure used to model and, subsequently, to evaluate the capacity of the buildings, determines the damage index usable to quantify the damage accumulated by the structure. In our case, the buildings are modeled using macro-elements, and their capacity is evaluated on the basis of an equivalent SDOF system. Therefore, using these models and procedures to calculate their capacity, only global response quantities and rough estimations of the global damage can be calculated (Kappos 1997).

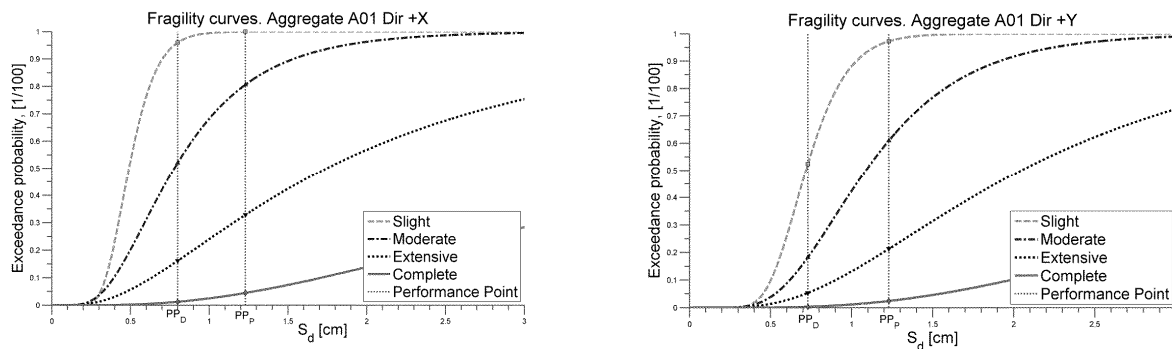

Figure 17. Fragility curves in +X and +Y directions for the aggregate A01. Spectral displacements corresponding to the performance points (deterministic and probabilistic earthquake scenarios).

TABLE 8
Mean values and standard deviation of the fragility curves of the analyzed buildings and aggregate for the +X and +Y directions

Building	Direction	S_{d1} [cm]	β_1	S_{d2} [cm]	β_2	S_{d3} [cm]	β_3	S_{d4} [cm]	β_4
M01	X	0.49	0.28	0.70	0.31	2.27	0.95	7.02	0.88
	Y	0.64	0.28	0.94	0.39	1.63	0.57	3.55	0.63
A01	X	0.49	0.28	0.78	0.53	1.74	0.79	4.71	0.79
	Y	0.72	0.28	1.09	0.44	2.05	0.64	4.80	0.69
M02	X	0.53	0.28	0.76	0.30	2.54	0.97	7.97	0.89
	Y	0.74	0.28	1.05	0.29	1.50	0.38	2.60	0.45
M03	X	0.48	0.28	0.68	0.30	0.98	0.39	1.72	0.46
	Y	0.41	0.28	0.62	0.43	1.18	0.64	2.75	0.69

The damage index, DI, also known as the mean damage value (normalized), works as an indicator of the global expected damage in the structure. It is also used to generate seismic risk scenarios in urban areas. The main characteristic of this value is the ease and prompt evaluation of the seismic behavior of the structures. It is defined as shown in Equation 2:

$$DI = \frac{1}{n} d_m = \frac{1}{n} \sum_{i=0}^n i \times P(ds_i) \quad (2)$$

where DI is the damage index, n is the number of damage states, and P(ds_i) is the probability that a damage state i occurs. According to this definition, this damage index is a quantity in the range [0, 1], so that the value 0 is associated to the absence of damage in the structure, while the value of 1 (100%) is associated to collapse, understood as a full or complete damage.

Table 9 and Table 10 show the main results of this work. Table 9 corresponds to the deterministic earthquake scenario. Table 10 corresponds to the probabilistic case. These results are discussed in the following section.

TABLE 9
Damage states probabilities, performance point (PP) and damage index (DI) associated to the deterministic scenario. Damage states: no damage (NO), slight (SL), moderate (MO), severe (SE) and complete (CO)

	Dir	Deterministic					PP [cm]	DI [%]
		NO [%]	SL [%]	MO [%]	SE [%]	CO [%]		
M01	+X	4.3	31.2	51.1	12.7	0.7	0.79	43.5
	+Y	36.4	40.9	15.8	6.4	0.5	0.70	23.4
A01	+X	4.1	43.9	35.9	14.9	1.2	0.80	41.4
	+Y	47.7	34.1	12.9	5.0	0.3	0.73	19.1
M02	+X	3.8	28.7	54.1	12.8	0.6	0.87	44.4
	+Y	53.3	37.3	6.8	2.4	0.2	0.72	14.7
M03	+X	1.4	18.0	41.3	32.0	7.3	0.88	56.4
	+Y	0.6	24.5	45.7	25.1	4.1	0.83	51.9

TABLE 10
Damage states probabilities, performance point (PP) and damage index (DI) associated to the probabilistic scenario. Damage states: no damage (NO), slight (SL), moderate (MO), severe (SE) and complete (CO)

	Dir	Probabilistic					PP [cm]	DI [%]
		NO [%]	SL [%]	MO [%]	SE [%]	CO [%]		
M01	+X	0.0	0.6	65.4	29.8	4.2	1.53	59.4
	+Y	1.7	28.4	43.0	23.2	3.7	1.15	49.7
A01	+X	0.1	19.3	47.7	28.4	4.5	1.23	54.5
	+Y	2.7	36.3	39.7	18.9	2.4	1.23	45.5
M02	+X	0.0	1.6	70.5	25.2	2.7	1.44	57.2
	+Y	6.0	33.4	37.2	20.0	3.4	1.14	45.4
M03	+X	0.0	0.4	13.3	48.0	38.3	1.50	81.0
	+Y	0.0	2.0	32.9	45.9	19.2	1.51	70.6

7. Discussion of the results

The main objectives of this work have been to study URM modernist buildings typical of the Eixample district of Barcelona and to assess their seismic vulnerability and risk. The evaluation has been made with the advanced methods proposed in the Risk-UE project. A discussion is made on the basis of the damage states probabilities and the damage index obtained for different isolated buildings and for the aggregate. We analyzed the buildings in two directions: +X (parallel to the street) and +Y. Both directions correspond to the main inertia directions of the buildings. +X is the direction corresponding to the shorter side of the buildings and is also the direction where the buildings are aggregated, while +Y is orthogonal to +X, and corresponds to the longest side of most of the buildings.

An important effort has been focused on the buildings modeling. It has been evidenced that all the existing structural elements of the analyzed buildings influence directly their behavior and, hence, on the calculations and results. In our study, existing floor plans of the analyzed buildings did not include all structural details. This was usual at the beginning of the 20th century when most architects used to include in their projects only partial information. To complete these undocumented building details, a methodical research of contemporary bibliographic funds and public architectural databases was performed. The research included also several field works that allowed checking the buildings and their structural elements today. This research allowed evolving the building models from their initial conception, incomplete in any case, to the current one, which we consider accurate and reliable. Several conclusions have been outlined from the analysis performed by using these models.

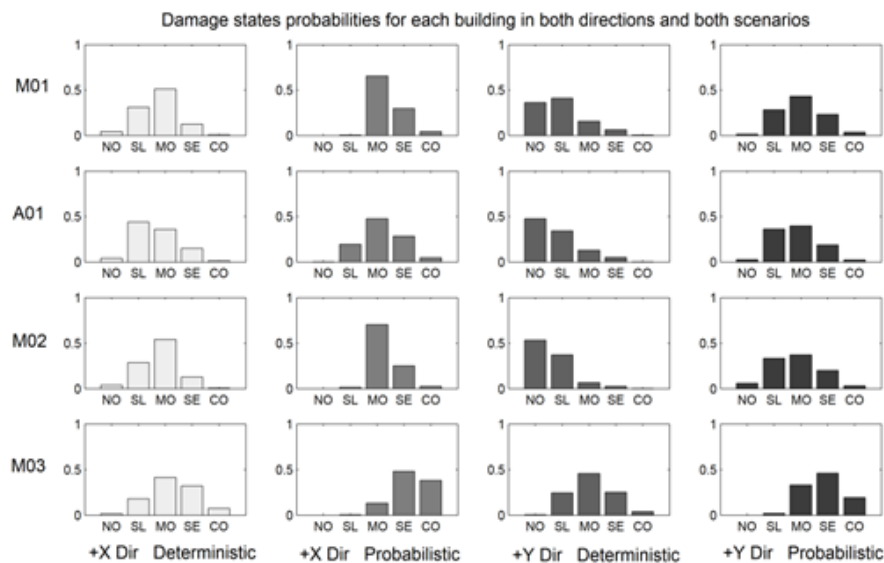

Figure 18. Probabilities of occurrence of each damage state. Values of Tables 9 and 10.

Within the earthquake scenarios context, and according to the obtained fragility curves (Figure 17), the probabilistic scenario shows higher damage values and worst performance than the deterministic scenario, in consistency with the values of the PGA obtained for both scenarios. This pattern is common for both analyzed directions. Figure 18 displays the data of Table 9 and Table 10 summarizing these trends. Associated to the deterministic scenario, higher values were obtained of the damage index related to the +X direction than to the +Y direction. This difference is negligible only in the case of the building M03 which has a more squared floor plan than the other analyzed buildings. Except building M03, the damage state probabilities in the +X

direction are centered between the slight and moderate states, while for the +Y direction the damage is centered between the no damage and the slight damage states (Figure 18). These results indicate that the expected damage associated to these URM buildings of Barcelona is predominantly moderate with non-negligible values of exceedance probability related to the severe damage state (Figure 18, Table 9 and Table 10).

An interesting observation can be made comparing the results related to the isolated building M01 to the results obtained for the aggregate A01, which is, in fact, the building M01 replicated. The damage indices results for the isolated building and for both analyzed directions (+X and +Y) are higher than those obtained for the aggregate. This difference is remarkable especially when we evaluate the difference related to the +Y direction where the damage index of the isolated building is 0.234 while the corresponding to the aggregate is 0.191. The same trend is obtained when the damage indices are calculated for deterministic and probabilistic scenarios. The differences related to both analyzed directions indicate that the seismic performance is improved when the buildings are aggregated. Probably, also in this case, because the aggregate is more regular than the isolated building, particularly in the +Y direction.

In all the cases, and for both scenarios, the analysis of the fragility curves and damage indices indicates that the buildings have a better performance in the +Y direction. Regarding the wall density, and in an attempt to relate the seismic performance in each direction with the wall density, an additional analysis has been performed. For the upper levels (levels from 2 to 7), the +X direction the buildings have thicker walls than in the +Y direction, but also a larger number of openings which are not present in the +Y direction. In spite of the presence of openings, the wall density in +X direction remains slightly higher than the one in +Y direction (Tables 1 to 4). For the first level, the wall density in the +Y direction is significantly higher than in the +X direction. This is due to the absence of inner walls at this level. The presence of metallic columns and girders allows an open space at this level which is commonly used for trading or catering activities. Nevertheless, the relationship between damage and wall density is somehow unclear since, for upper stories, the wall density is slightly higher in the +X direction, while the seismic performance related to the +X direction is worse. In our opinion, rather than considering parameters related to the area of the cross section of the walls, mechanical parameters related to the inertia of the walls in each direction should be evaluated and correlated in order to explain the greater vulnerability in the +X direction.

The initial stiffness of the buildings in both directions was evaluated (Table 11). The results indicate a greater stiffness associated to the +Y direction due to the higher inertia related to this direction. Even if the buildings have a squared floor plan, these differences still exist because the inertia relative to the centered axis parallel to +X direction still continues being greater than in the +Y direction.

TABLE 11
Elastic Stiffness of the analyzed buildings

Building	Elastic Stiffness	
	+X direction K_x (kN/cm)	+Y direction K_y (kN/cm)
M01	1900	2100
A01	4000	4000
M02	900	1250
M03	625	800

As a general remark and for both scenarios, the buildings analyzed as isolated show a higher vulnerability in the +X direction (short direction). Nevertheless, this conclusion is true for buildings which have a rectangular floor plan (M01 and M02), while the buildings with a more

squared floor plan (M03) show closer values of fragility and, thus, damage in both directions (Table 9 and Table 10). In addition, the aggregate buildings in this case improve the performance of the isolated buildings in the +X direction. Thus, the aggregate has a better performance as a group than the one of each isolated building composing it. These statements should be confirmed via stochastic studies on a higher number of isolated buildings and aggregates, in order to determine the trend and its validity.

A risk assessment on URM buildings of Barcelona was performed in Pujades et al. (2012) where the buildings and their models were slightly different from those analyzed in this article. The main model difference is the five stories height of those buildings, while seven stories buildings are studied herein. It is significant that in both analyses, despite the results differences showing lower values for the damage indices in this work, the same trends are observed. A better performance is obtained for the deterministic scenario than for the probabilistic one and, in both works, the buildings show lower values of the damage indices in direction +Y than in the direction +X. A careful comparison revealed differences in the buildings characteristics and in the calculation of the performance point. We analyzed herein seven stories buildings with detailed and complete models while there, more simplified buildings models of five stories were studied. In addition, Pujades et al. (2012) uses the linear equivalent approach to obtain the performance point. It is well known that the linear equivalent approach leads to conservative results. For the present study the iterative approach, known as the procedure A, described in the ATC-40 (1996, PA-8) has been preferred as being more realistic. Therefore, in our opinion, the already indicated differences in the geometry of the buildings, but mainly in the use of more realistic strength parameters and in the approach used to obtain the performance point, may explain the differences in the values of the damage indices. Nevertheless, it is also remarkable that, despite these significant differences, the same trends and comparable results are obtained in both studies, showing the robustness of the approaches and methods used.

8. Conclusions

The modernist buildings of the Eixample district are emblematic constructions of Barcelona that must be preserved in spite of their overall vulnerability. In this article, an exhaustive investigation to identify all the structural characteristics of these modernist buildings has been carried out. A complete knowledge of the buildings is necessary to approach any calculation involving nonlinear approaches.

This study used an advanced structural model and an outstanding and internationally recognized program code to carry out the incremental nonlinear calculations of the studied URM buildings. One of the main objectives of this work has been the assessment of their seismic performance and expected damage starting from their capacity and fragility curves and calculating their damage indices which allow assessing their seismic vulnerability and risk.

The obtained results evidence that for the probabilistic scenario the buildings show higher damage values and worse performance than for the deterministic scenario; this trend is maintained for both analyzed directions. The obtained damage indices are higher for the isolated building than for the aggregate, indicating this fact that the seismic performance is specifically improved for the analyzed aggregate. The same trend is obtained when the damage indices are calculated for deterministic and probabilistic scenarios and for both analyzed directions.

As a general remark and for both earthquake hazard scenarios, the buildings analyzed as isolated show a higher vulnerability in the +X direction (the shorter one), which is the direction in which they have a wall density slightly higher than in the +Y direction. In the opinion of these study authors, rather than considering the wall density as a criterion of comparison, the

mechanical parameters related to the inertia of the walls in each direction should be correlated to the damage indices in order to explain the greater vulnerability in the +X direction.

The modernist URM buildings of Barcelona are undergoing a constant process of refurbishment, renovation and conventional repair. The results obtained in this study indicate that the expected seismic damage of these buildings is predominantly moderate with non-negligible values of exceedance probability related to the severe damage state. In consequence, and due to their significant seismic vulnerability, the renovation and refurbishment works should be performed considering also seismic criteria. This statement is made even if Barcelona is located in a zone of low to moderate seismicity; however, this study, as well as previous works, shows that these structures can be significantly affected by low to moderate earthquakes due to their important vulnerability.

Acknowledgements

The authors also would like to thank Professor Francisco Rosselló for his useful bibliographical support and for his priceless observations and comments about several architectural and structural details of the URM buildings of the Eixample district of Barcelona.

Funding

This work has been partially funded by the Spanish Government, by the European Commission and with FEDER funds, through the research projects: CGL2008-00869/BTE, CGL2011-23621, SEDUREC-CONSOLIDER-CSD2006-00060, INTERREG: POCTEFA 2007-2013/73/08, MOVE-FT7-ENV-2007-1-211590 and DESURBS-FP7-2011-261652.

References

- Ambrasseys, N. N., Simpson, K. A. and Bommer, J. J. 1996. Prediction of horizontal response spectra in Europe. *Earthquake Engineering and Structural Dynamics* **25**:371-400.
- ATC-40. 1996. *Seismic evaluation and retrofit of concrete buildings*. Redwood City, CA: Seismic Safety Commission, USA.
- Barbat, A. H., Mena, U. and Yépez, F. 1998. Evaluación Probabilista del Riesgo Sísmico en Zonas Urbanas. *Revista Internacional de Métodos Numéricos para Cálculo y Diseño en Ingeniería*. **14**:247-268.
- Barbat, A. H., Pujades, L. G. and Lantada, N. 2006a. Performance of buildings under earthquake in Barcelona, Spain. *Computer-Aided Civil and Infrastructure Engineering*. **21**:573-593.
- Barbat, A. H., Lagomarsino, S. and Pujades, L. G. 2006b. Vulnerability assessment of dwelling buildings. In *Assessing and managing earthquake risk*. Eds., C. S. Oliveira, A. Roca and X. Goula. Dordrecht, The Netherlands: Springer, 115-134.
- Barbat, A. H., Pujades, L. G. and Lantada, N. 2008. Seismic damage evaluation in urban areas using the capacity spectrum method: application to Barcelona. *Soil Dynamics and Earthquake Engineering*. **28**:851-865.
- Calderini C, Cattari S and Lagomarsino S. 2009. In-plane strength of unreinforced masonry piers. *Earthquake Engineering and Structural Dynamics*. **38**(2):243-267.
- Carreño, M. L., Cardona, O. D. and Barbat, A. H. 2007. Urban seismic risk evaluation: A holistic approach. *Natural Hazards*. **40**:137-172.
- CCCB, 2009. *Cerdà and the Barcelona of the future. Reality versus project*. <http://www.cccb.org/exposicio-cerda> [accessed May 2012].
- Cid, J. 1998. *Zonación Sísmica de la ciudad de Barcelona basada en métodos de simulación numérica de efectos locales*. Universidad Politécnica de Cataluña. PhD thesis. Barcelona, Spain.

- Egozcue, J., A.H. Barbat, J.A. Canas, J. Miquel and E. Banda. 1991. A method to estimate occurrence probabilities in low seismic activity regions. *Earthquake Engineering and Structural Dynamics*. **20**(1):43-60.
- EUROSTAT. 2011. *EUROSTAT Yearbook 2010: General and regional statistics*. Luxemburg city, Luxemburg: Statistical Office of the European Union.
- Faccioli, E. and C. Cauzzi. 2006. Macroseismic intensities for seismic scenarios estimated from instrumentally based correlations. In *Proceedings of the 1st European Conference on Earthquake Engineering and Seismology*. Geneva, Switzerland. Paper No. 569.
- Federal Emergency Management Agency and National Institute of Building Sciences (FEMA/NIBS). 1999. *HAZUS'99 technical manual. Earthquake loss estimation methodology*. Washington DC: FEMA/NIBS.
- Galasco, A., S. Lagomarsino and A. Penna. 2006. On the use of pushover analysis for existing masonry buildings. In *Proceedings of the 1st European Conference on Earthquake Engineering and Seismology*. Geneva, Switzerland. Paper No. 1080.
- Gambarotta, L. and Lagomarsino, S. 1997. Damage model for the seismic response of brick masonry shear walls. Part II: the continuum model and its applications. *Earthquake Engineering and Structural Dynamics*. **26**:441-462.
- González, H. F. 2010. *Comportamiento sísmico de edificios con muros delgados de hormigón. Aplicación a zonas de alta sismicidad de Perú*. Universidad Politécnica de Cataluña. PhD thesis. Barcelona, Spain.
- Grünthal G., C. Bosse, S. Sellami, D. Mayer-Rosa and D. Giardini. 1999. Compilation of the GSHAP regional seismic hazard for Europe, Africa and the Middle East. *Annali di Geofisica*. **42**:1215-1223.
- Irizarry, J. 2004. *An advanced approach to seismic risk assessment. Application to the cultural heritage and the urban system of Barcelona*. Universidad Politécnica de Cataluña. PhD thesis. Barcelona, Spain.
- Jiménez, M. J., Giardini, D., Grünthal, G. A. and SESAME-Working Group. 2001. Unified seismic hazard modelling throughout the Mediterranean region. *Bolletino di Geofisica Teorica ed Applicata*. **42**(1-2):3-18.
- Kappos, A. J. 1997. Seismic damage indices for RC buildings: evaluation of concepts and procedures. *Progress in Structural Engineering and Materials*. **1**(1):78-87.
- Kennedy R.P., C.A. Cornell, R.D. Campbell, S. Kaplan and H.F. Perla. 1980. Probabilistic seismic safety study of an existing nuclear power plant. *Nuclear Engineering and Design*. **59**(2):315-338.
- Lagomarsino S., A. Galasco and A. Penna. 2002. Pushover and dynamic analysis of 3D masonry buildings by means of a non-linear macro-element model. In *Proceedings of International Conference on Earthquake Loss Estimation and Risk Reduction*. Bucharest, Romania.
- Lagomarsino, S., Galasco, A., Penna, A. and Cattari, S. 2008. TREMURI: Seismic analysis program for 3D masonry buildings (User Guide). *Technical Report*. Genoa, Italy.
- Lantada, N. 2007. Evaluación del riesgo sísmico mediante métodos avanzados y técnicas GIS: Aplicación a Barcelona. PhD. Universidad Politécnica de Cataluña. PhD thesis. Barcelona, Spain.
- Lantada, N., Pujades, L. and Barbat, A. 2009. Vulnerability index and capacity spectrum based methods for urban seismic risk evaluation. A comparison. *Natural Hazards*. **51**:501-524.
- Milutinovic, Z. V. and Trendafiloski, G. S. 2003. WP4: Vulnerability of Current Buildings. *RISK-UE Project Handbook*. **1**:111.
- Ministerio de la Vivienda. 1963. *Norma MV 101-1962. Acciones en la Edificación. Spanish Official Bulletin*. Madrid, Spain: Ministerio de la Vivienda.
- Ministerio de la vivienda. 1988. *NBE-AE/88 Norma Básica de la Edificación. Acciones en la Edificación, Spanish Official Bulletin*. Madrid, Spain: Ministerio de la Vivienda.
- Ministerio de Fomento. 2006. *Código Técnico de la Edificación. Spanish Official Bulletin*. Madrid, Spain: Ministerio de Fomento.
- PIET 70. 1971. *Obras de fábrica. Prescripciones del Instituto Eduardo Torroja*. Madrid, Spain: Consejo Superior de Investigaciones Científicas.
- Paricio, A. 2008. *Secrets d'un sistema constructiu L'Eixample*. Barcelona, Spain: Ed.UPC.
- Pujades, L.G., A.H. Barbat, R. Gonzalez-Drigo, J. Avila and S. Lagomarsino. 2012. Seismic performance of a block of buildings representative of the typical construction in the Eixample district in Barcelona (Spain). *Bulletin of Earthquake Engineering*. **10**(1):331-349.
- Schindler, R. and Bassegoda, B. 1955. *Tratado moderno de construcción de edificios*. Barcelona, Spain. José Montesó Editor.

- Secanell, R., X. Goula, T. Susagna, J. Fleta and A. Roca. 2004. Seismic hazard zonation of Catalonia, Spain integrating uncertainties. *Journal of Seismology*. **8**(1)24-40.
- United States Bureau of the Census. 1991. *Report WP/91, World population profile: 1991*. Washington, DC: Government Printing Office.
- Yépez, F., Barbat, A. H. and Canas, J.A. 1996. Simulación de escenarios del daño sísmico en zonas urbanas. *Revista Internacional de Métodos Numéricos para Cálculo y Diseño en Ingeniería*. **12**:331-358.