



RESEARCH

Adsorption of hydrogen sulphide over rhodium/silica and rhodium/alumina at 293 and 873 K, with co-adsorption of carbon monoxide and hydrogen

Claire Gillan¹  · Martin Fowles² · Sam French² · S. David Jackson¹Received: 17 November 2015 / Accepted: 24 May 2017 / Published online: 27 May 2017
© The Author(s) 2017. This article is an open access publication

Abstract In this study, we have examined the adsorption of hydrogen sulphide and carbon monoxide over rhodium/silica and rhodium/alumina catalysts. Adsorption of hydrogen sulphide was measured at 293 and 873 K and at 873 K in a 1:1 ratio with hydrogen. At 293 K, over Rh/silica, hydrogen sulphide adsorption capacity was similar to that of carbon monoxide; however, over Rh/alumina, the carbon monoxide adsorption capacity was higher, probably due to the formation of $\text{Rh}^{\text{I}}(\text{CO})_2$. Over Rh/silica, the primary adsorbed state was $\text{HS}(\text{ads})$, in contrast to Rh/alumina, where the $\text{H}_2:\text{S}$ ratio was 1:1 indicating that the adsorbed state was $\text{S}(\text{ads})$. Competitive adsorption between CO and H_2S over Rh/silica and Rh/alumina revealed adsorption sites on the metal that only adsorbed carbon monoxide, only adsorbed hydrogen sulphide or could adsorb both species. At 873 K, hydrogen sulphide adsorption produced the bulk sulphide Rh_2S_3 ; however, when a 1:1 $\text{H}_2:\text{H}_2\text{S}$ mixture was used formation of the bulk sulphide was inhibited and a reduced amount of hydrogen sulphide was adsorbed.

Keywords Rhodium · Hydrogen sulphide · Carbon monoxide · Adsorption

Introduction

Catalyst poisoning is the strong chemisorption of a species on a site otherwise available for catalysis. Whether a species is a poison depends upon its adsorption strength relative to other species competing for active sites. For many reactions, such as methanation, methanol synthesis and Fischer–Tropsch synthesis, over group 8–11 metal catalysts, sulphur is a known poison [1]. To be able to interpret quantitatively the extent and nature of poisoning by sulphur, it is essential to know the structure and bonding of sulphur to metal atoms at the surface. There are two types of sulphides that form on a catalyst, 2-D surface sulphides and 3-D bulk sulphides, the formation of which requires the metal cation to diffuse through the adsorbed sulphide layer [2] forming a new metal sulphide layer on the outer surface. This phenomenon of segregation is strongly exothermic and is therefore favoured by a reduction in temperature. Surface sulphide formation is simply the adsorption of sulphur on the surface of the metal. Pt, Ni, Ru and Rh all have lower free energies of formation of their bulk sulphides than their surface sulphides, hence, large hydrogen sulphide concentrations are required for stable bulk sulphides to exist.

It has also been inferred that an SH surface species is present as an intermediate in the dissociation of hydrogen sulphide. For example, over $\text{Pt}/\text{Al}_2\text{O}_3$, it was observed that at increasing sulphur coverages, dissociated hydrogen is gradually desorbed but that a percentage spends a significant lifetime on the catalyst [3], and can participate in reactions. Also, on Pt/alumina two types of adsorbed hydrogen sulphides were detected, different due to strengths of adsorption and three different adsorption sites. These include: a site which bonds sulphur strongly and will not exchange, a site which bonds sulphur weakly and is

✉ S. David Jackson
david.jackson@glasgow.ac.uk

¹ Centre for Catalysis Research, WestCHEM, School of Chemistry, University of Glasgow, Glasgow G12 8QQ, Scotland, UK

² Johnson Matthey Plc, Belasis Ave, Billingham TS23 1LB, UK

removed under vacuum and a site which will allow exchange between gas and adsorbed phases. These were determined from radioactive labelling experiments [4], in which it was also found that the S:Pt_(surface) ratio was 1:1 on Pt/SiO₂ but only 0.6:1 on Pt/Al₂O₃. There has been limited research on the adsorption of sulphur species on Rh catalysts; however, some work has been conducted on Rh single crystal faces. Hedge and White [5] studied the chemisorption and decomposition of H₂S on Rh(100) at 100 K using auger electron spectroscopy (AES) and obtained results suggesting a saturation coverage near 0.5 monolayer. On heating to 600 K, the sulphur coverage increased, which the authors inferred was due to physisorbed H₂S, which is consistent with results for H₂S adsorption on Pt and Ni. The thermal desorption spectra of molecular H₂S from Rh(100) exhibit low- and high-temperature peaks, hence, Hedge and White [5] assigned the low temperature peak as physisorbed H₂S. It was also found that a decreasing fraction of H₂S dissociated as the coverage of H₂S increased [5]. The similarities between H₂S adsorption on Rh(100) and Pt(111), Ru(110) and Ni(100) were noted. In all these cases, there is complete dissociative adsorption at low temperatures and low coverages with hydrogen remaining on the surface. At low temperatures and higher coverages on Pt(111), Ru(110) and Ni(100), first SH and then H₂S were observed.

In catalytic systems, the sulphur compound is not there in isolation, rather it is there coincidentally with the reactants. However, studies where competitive adsorption has been examined are rare and over rhodium rarer still. The interaction of CO and H₂S over supported Pt catalysts was studied in detail by Jackson et al. [6], who found that when H₂S was pre-adsorbed on Pt/silica no subsequent CO adsorption was detected due to the adsorption of H₂S being dissociative, so there was no mechanism by which sulphur could desorb, and hence no sites can be liberated for CO adsorption. When CO was pre-adsorbed on Pt/silica, the amount of H₂S adsorbed was reduced by 81% in comparison to a fresh surface, though it was suggested that 20% of the H₂S was able to adsorb onto the silica support, indicating that CO had completely suppressed H₂S adsorption on the Pt sites. However, when the same experiment was carried out over Pt/alumina [6], there was no reduction in adsorptive capacity for H₂S on a CO saturated surface indicating that CO did not block H₂S adsorption on the metal sites, and therefore must be related to the effect of the support. It has previously been reported that CO₂ is produced from the reaction of adsorbed CO with hydroxyl groups from the alumina support [6], therefore, it was proposed that CO may be able to desorb via this route liberating sites for H₂S adsorption. When CO and H₂S were co-fed over Pt/silica the amount of H₂S adsorbed decreased by 78%, whereas the amount of CO adsorbed increased by 67%. The enhancement in CO adsorption was explained by

the adsorption of H₂S and its displacement by CO. This caused desorption of residual hydrogen from the reduction procedure, possibly by surface reconstruction, which had been found to have a deleterious effect on CO adsorption [6].

A similar study examining the interaction of CO and H₂S over Rh/silica catalysts was carried out [7], but unlike Pt, it was found that CO could adsorb onto samples that had been saturated with sulphur. Displacement of H₂S was also evident, but this was dependent on the metal precursor used. It was only found to occur on an oxide-derived catalyst, and since the desorption of sulphur requires hydrogen, it was proposed that H₂S only partially dissociates on the oxide catalyst to produce an HS-* species, which would provide a source of hydrogen to allow for desorption [7]. The effect of passing H₂S over CO pre-covered surfaces was the displacement of CO and the adsorption of H₂S, i.e. similar to Pt/alumina. It was speculated that the CO displaced, reflected the different modes of adsorbed CO, and this was also found to be dependent on the metal precursor. For example, a chloride-derived catalyst appeared to displace bridge-bonded Rh₂-CO [7].

This work follows on from a study over Pt/alumina and Pt/silica where the adsorption of hydrogen sulphide was examined in relation to its effect on steam reforming [8]. In this study, the adsorption of hydrogen sulphide and methanethiol over Rh/silica and Rh/alumina at 293 K will be examined and the amount compared with that found from carbon monoxide chemisorption. In this way, the total amount of hydrogen sulphide adsorption can be measured and related to the amount of surface rhodium. Competitive adsorption of carbon monoxide and hydrogen sulphide will be examined as it is rare that a poison is present in the absence of another species (reactant or product). By comparing the competitive adsorption, an assessment can be made as to the relative strength of adsorption between carbon monoxide and hydrogen sulphide. The extent hydrogen sulphide may adsorb in the presence of carbon monoxide can give an insight into sulphur poisoning of carbon monoxide hydrogenation over rhodium. The adsorption of hydrogen sulphide will be examined at high temperature (873 K) in the absence and presence of hydrogen, to understand whether hydrogen is effective at reducing the amount of sulphur adsorbed. Le Chatelier's principle indicates that the amount of sulphur adsorbed should be reduced; however this will be the first experimental verification. This will inform our understanding of sulphur poisoning in systems such as steam reforming.

Experimental

Two catalysts were prepared on alumina and silica, 1.2% w/w Rh/alumina and 1% Rh/silica. Both catalysts were prepared by incipient wetness of the two supports (θ -

alumina, surface area $101 \text{ m}^2 \text{ g}^{-1}$; silica, surface area $220 \text{ m}^2 \text{ g}^{-1}$) using $\text{Rh}(\text{NO}_3)_3$ hydrate (Aldrich) as the precursor salt. The precursor salt was dissolved in a volume of distilled water equal to the support pore volume ($0.6 \text{ cm}^3 \text{ g}^{-1}$ for alumina and $1 \text{ cm}^3 \text{ g}^{-1}$ for silica) using 100 g of support. The catalysts were dried and calcined at 773 K for 4 h. The rhodium weight loading was confirmed by atomic adsorption.

Chemisorption studies were performed in a dynamic mode using a pulse-flow microreactor system in which the catalyst sample was placed on a sintered glass disc in a vertical tube (8 mm id, down flow) inside a furnace (Fig. 1).

The reactant pulses were introduced into the gas stream immediately before the catalyst bed using a fixed volume sample loop. Using this system, the catalysts (typically 0.50 g) were reduced in situ in a flow of hydrogen ($40 \text{ cm}^3 \text{ min}^{-1}$) by heating to 673 K at a rate of 10 K min^{-1} . The catalyst was held at this temperature for 2 h. The catalyst was then purged with argon ($40 \text{ cm}^3 \text{ min}^{-1}$) for 30 min and the catalyst was cooled in flowing argon to 293 K. The adsorbate gases were admitted by injecting pulses of known size (typically $24 \mu\text{mol}$) into the argon carrier-gas stream, and hence onto the catalyst. The residence time of the pulse in the catalyst bed was $\sim 1.5 \text{ s}$. In all cases, the whole pulse was analysed by on-line GC. For co-adsorption studies, the gases were mixed in the gas manifold prior to injection into the carrier gas. The amount of gas adsorbed, from any pulse, was determined from the difference between the peak area of a calibration pulse sent directly to the GC from the sample volume, and the peak area obtained following the injection of pulses of comparable size onto the catalyst. The detection limit for adsorption was $0.3 \mu\text{mol g}^{-1}$. Adsorption measurements

were typically repeated three times and the values reported are the average. Standard deviation on the amount adsorbed was typically less than $\pm 8\%$. Adsorptions were followed using a gas chromatograph fitted with a thermal conductivity detector and Molecular Sieve 5A and Porapak Q columns.

Both the helium (BOC, 99.997%) and the 5% hydrogen in dinitrogen (BOC) were further purified by passing through Chrompack Gas-Clean Oxygen filter to remove any oxygen impurity, and a bed of Chrompack Gas-Clean Moisture filter to remove any water impurity. Carbon monoxide (99.99% Research Grade) and hydrogen sulphide ($>99\%$) were used as received.

Results

Carbon monoxide and hydrogen sulphide adsorption was examined over the high weight-loading rhodium catalysts. As described in the “Experimental” section, multiple pulses of each gas were passed over the catalysts until no further adsorption was detected. Using this methodology, the pressure of the pulse is always 1 bar and only strongly bound species are detected. As expected, no adsorption of carbon monoxide was detected on the alumina or silica supports in the absence of the metal component. Carbon monoxide adsorption gave $143.8 \mu\text{mol g}^{-1}$ for Rh/alumina and $65.1 \mu\text{mol g}^{-1}$ for Rh/silica (this translates to metal dispersions of 123% for Rh/alumina and 67% for Rh/silica assuming a Rh:CO ratio of 1:1). The silica support did not adsorb hydrogen sulphide, but hydrogen sulphide did adsorb on the alumina, hence, the adsorption data for the Rh/alumina catalyst has had the support contribution subtracted from the total adsorption. The hydrogen sulphide adsorption data are reported in Table 1.

The adsorption of hydrogen sulphide and carbon monoxide was also studied by co-adsorption, carbon monoxide pre-adsorbed before hydrogen sulphide and vice versa. The results are shown in Table 2. For co-adsorption, pulses of the mixed gases at a 1:1 ratio were passed over the catalyst. For the sequential adsorptions, one gas was

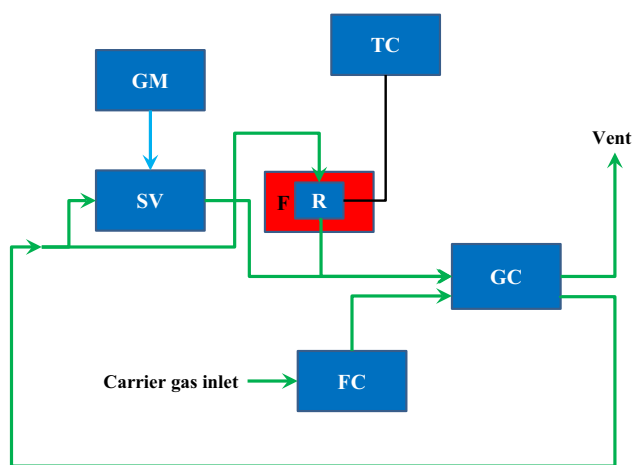

Fig. 1 Schematic of pulse-flow microreactor. *GM* gas manifold, *SV* standard volume, *F* furnace, *R* reactor, *TC* temperature controller, *FC* flow controller, *GC* gas chromatograph with a thermal conductivity detector

Table 1 Hydrogen sulphide adsorption at 293 K

Catalyst	H_2S adsorbed ^a	$\text{H}_2:\text{S}(\text{ads})^b$	Dispersion ^c (%)
Rh/alumina	112.7	1.0:1	97
Rh/silica	61.2	0.7:1	63

^a $\mu\text{mol g}^{-1}$

^b H_2 evolved during adsorption relative to H_2S adsorbed

^c Calculated on the basis of the hydrogen sulphide adsorption, assuming a 1:1 S:Rh

Table 2 Sequential and co-adsorption of carbon monoxide and hydrogen sulphide at 293 K ($\mu\text{mol g}^{-1}$)

Rh/alumina			
H ₂ S pre-adsorbed	CO adsorbed after H ₂ S adsorption		
112.7	14.7		
CO pre-adsorbed	H ₂ S adsorbed after CO adsorption	H ₂ :S(ads) ^a	
143.8	25.0	0.3:1	
Co-adsorption	CO adsorbed	H ₂ S adsorbed	H ₂ :S(ads)
	64.9	30.1	0.3:1
Rh/silica			
H ₂ S pre-adsorbed	CO adsorbed after H ₂ S adsorption		
61.2	7.7		
CO pre-adsorbed	H ₂ S adsorbed after CO adsorption	H ₂ :S(ads)	
65.1	9.0	0.6:1	
Co-adsorption	CO adsorbed	H ₂ S adsorbed	H ₂ :S(ads)
	21.3	17.4	0.7:1

^a H₂ evolved during adsorption relative to H₂S adsorbed

Table 3 Hydrogen sulphide adsorption at 873 K

Catalyst	H ₂ S adsorbed ^a	H ₂ :S(ads) ^b	Rh:S(ads) ^c
Rh/alumina	166.5	0.8:1	1:1.4
Rh/silica	152.5	1.0:1	1:1.5

^a $\mu\text{mol g}^{-1}$

^b Ratio of hydrogen evolved to sulphur adsorbed

^c Ratio of Rh to sulphur adsorbed

Table 4 Hydrogen sulphide adsorption from a 1:1 H₂S:H₂ mixture at 873 K

Catalyst	H ₂ S adsorbed ^a	H ₂ :S(ads) ^b	Rh:S(ads) ^c
Rh/alumina	90.4	0.7:1	1:0.8
Rh/silica	98.3	0.8:1	1:1.0

^a $\mu\text{mol g}^{-1}$

^b Ratio of hydrogen evolved to sulphur adsorbed

^c Ratio of Rh to sulphur adsorbed

adsorbed to saturation (so if CO was pre-adsorbed the catalyst would be saturated with CO) before the second gas was passed over the catalyst.

The adsorption of hydrogen sulphide was also studied at 873 K in the absence and presence of hydrogen and the results are shown in Tables 3 and 4, respectively. When the hydrogen sulphide was adsorbed in the presence of hydrogen, the ratio of the mixture was 1:1. The amount of hydrogen sulphide adsorbed on the alumina at 873 K has been subtracted from the Rh/alumina adsorption in Tables 3 and 4. No adsorption took place on the silica.

Discussion

The adsorption of hydrogen sulphide on rhodium has only been studied sparingly [5, 7, 9, 10]. Nevertheless, there is good agreement about what is expected from hydrogen sulphide adsorption at room temperature over highly dispersed Rh/silica catalysts. Our value of 0.6:1 S:Rh is typical for sulphur adsorption on Rh/silica [7, 9], as is the ~1:1 correspondence between hydrogen sulphide adsorption and carbon monoxide adsorption. Carbon monoxide adsorption over rhodium can be described by three adsorbed states, linear Rh–CO, bridge-bonded Rh₂–CO, and gem-dicarbonyl Rh^I(CO)₂. The ratio of CO:Rh obtained with the silica catalyst suggests principally bridged and linear sites, which implies a similar bonding model for sulphur. This is in accordance with the work of Sachtler et al. [10]. Over Rh/alumina, a S:Rh ratio of ~1:1 is obtained, which is higher than that observed with the silica catalyst. This is the opposite of what is found with carbon monoxide adsorption and hydrogen sulphide adsorption over Pt/alumina, where the alumina-supported catalyst gave a lower ratio [8]. The greater than 1:1 CO:Rh ratio was expected over the alumina supported catalyst, as it is known that the gem-dicarbonyl Rh^I(CO)₂ species can be formed leading to a greater than 1:1 ratio. Interestingly, the hydrogen sulphide adsorption follows the same trend as the carbon monoxide adsorption. It is normally assumed that sulphur occupies a multiply bonded site such as a threefold hollow [10] on a Rh(111) face, but the commonality in adsorption ratios between carbon monoxide and hydrogen sulphide suggests that on highly dispersed supported metals there may be a number of adsorption modes.

Further information on the mode of hydrogen sulphide adsorption can be obtained from the H₂:S ratio. The H₂:S ratio over the silica catalyst was 0.7:1, this implies that two adsorbed states are present, S(ads) and HS(ads), and we can obtain a ratio of these adsorbed states from a stoichiometric equation:

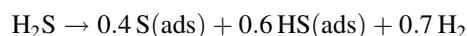

Therefore, over Rh/silica, the primary adsorbed state is HS(ads), which is not the case for Rh/alumina, where the H₂:S ratio is 1:1 indicating that the only adsorbed state is S(ads) (Tables 1, 2). This is different from the Pt/alumina and Pt/silica systems where both catalysts had a H₂:S ratio of ~0.7:1 [8], indicating that dissociation is enhanced over Rh/alumina.

When carbon monoxide was pre-adsorbed over the Rh/silica at 293 K and then hydrogen sulphide adsorbed over the same catalyst, the amount of hydrogen sulphide adsorbed was reduced by 85%. There was no evidence of carbon monoxide being displaced suggesting that the hydrogen sulphide was accessing sites that were

unavailable to carbon monoxide. The extent of hydrogen evolution indicates that the mode of hydrogen sulphide adsorption had changed, such that 80% of the adsorbed sulphur was in the form HS(ads). When hydrogen sulphide was pre-adsorbed and then carbon monoxide adsorbed over the same catalyst, the behaviour observed was similar to the CO/H₂S couple, but with the carbon monoxide adsorption reduced by 88%. The two sequential adsorption experiments suggest that there are three sites on the surface, one that adsorbs both carbon monoxide and hydrogen sulphide, one that adsorbs only hydrogen sulphide and one which only adsorbs carbon monoxide. These results are in accordance with the literature [7], where multiple sites were also proposed. However, when we consider the co-adsorption experiment, we find a much lower total adsorption (Table 2). The nature of the hydrogen sulphide adsorption appears similar in that the amount of hydrogen liberated during the adsorption is the same as for the single-gas adsorption. Nevertheless, the adsorption capacity has reduced. It is not clear why such a reduction takes place although both adsorbates may cause restructuring of the metal crystallites.

The sequential and competitive adsorptions over Rh/alumina are similar to those found with Rh/silica confirming the absence of a support effect and reinforcing the validity of the results. Once again, under co-adsorption the total amount of gas adsorbed is reduced (Table 2). As has been noted for the Rh/silica catalyst, both adsorbates can cause restructuring; however, when hydrogen and carbon monoxide were co-adsorbed [12] above 373 K, the hydrogen inhibited the formation of Rh^I(CO)₂ but enhanced sintering. This behaviour at least suggests a mechanism, whereby the total amount adsorbed could be reduced. Also, in the co-adsorption, there is a significant change in the amount of hydrogen retained by the adsorbed hydrogen sulphide. When hydrogen sulphide is adsorbed first, the amount of hydrogen desorbed is such that the adsorbed species is S(ads). However, when hydrogen sulphide is co-adsorbed with carbon monoxide, or when it is adsorbed after carbon monoxide pre-adsorption, the adsorbed sulphur retains ~2/3rd of the hydrogen, altering the adsorbed state to principally HS(ads) with the remainder adsorbed as non-dissociated hydrogen sulphide: $\text{H}_2\text{S} \rightarrow 0.4 \text{H}_2\text{S}(\text{ads}) + 0.6 \text{HS}(\text{ads}) + 0.3 \text{H}_2$

Therefore, the carbon monoxide appears to inhibit hydrogen sulphide dissociation.

It is noticeable that the amount of hydrogen sulphide adsorbed at 873 K is greater than that adsorbed at 293 K, which is the reverse of what would be expected. However, the adsorption of hydrogen sulphide at 873 K (Table 3) reveals a higher degree of dissociation approximating to the loss of all hydrogen and a S:Rh ratio of 1.4:1 for Rh/

alumina and 1.5:1 for Rh/silica. This suggests the formation of the bulk sulphide, Rh₂S₃. When hydrogen was co-fed with hydrogen sulphide at 873 K (Table 4), the amount of sulphur adsorbed decreased significantly (S:Rh ~ 1:1) and the degree of dissociation also decreased, but not by as much as found with platinum catalysts, where the H₂:S(ads) ratio decreased from 1:1 to 0.44 for Pt/alumina and 0.25 for Pt/silica [8]. This is to be expected, as we are now displacing the following equilibria to the left-hand side:



However, the extent of the displacement will be dependent upon thermodynamic factors, and under these conditions PtS₂ is unstable, so we may expect a larger move to the left. Nevertheless, it is clear that the addition of hydrogen was sufficient to inhibit the formation of the bulk sulphide and brings the system back closer to an adsorbed state. Indeed for Rh/silica, the adsorption gives $\text{H}_2\text{S} \rightarrow 0.6 \text{S}(\text{ads}) + 0.4 \text{HS}(\text{ads}) + 0.8 \text{H}_2$, which is similar to that found for room temperature adsorption.

Conclusions

In this study, we have examined the adsorption of hydrogen sulphide over rhodium/silica and rhodium/alumina catalysts at 293 and 873 K. At 293 K, over Rh/silica, hydrogen sulphide adsorption capacity was similar to that of carbon monoxide; however, over Rh/alumina, the carbon monoxide adsorption capacity was higher, probably due to the formation of Rh^I(-CO)₂. Over Rh/silica, the primary adsorbed state was HS(ads), which was not the case for Rh/alumina, where the H₂:S ratio was 1:1 indicating that the adsorbed state was S(ads). Sequential adsorption between CO and H₂S over Rh/silica and Rh/alumina at 293 K revealed adsorption sites on the metal that only adsorbed carbon monoxide, only adsorbed hydrogen sulphide, or could adsorb both species. Co-adsorption of carbon monoxide and hydrogen sulphide resulted in a much reduced total adsorption (40% for Rh/silica, 33% for Rh/alumina). The reason for this is not clear, but may relate to restructuring/sintering of the systems. At 873 K, hydrogen sulphide adsorption produced the bulk sulphide Rh₂S₃; however, when a 1:1 H₂:H₂S mixture was used, formation of the bulk sulphide was inhibited. The Rh:S ratio was reduced to ~1:1, and for Rh/silica a significant amount of HS(ads) was identified.

Open Access This article is distributed under the terms of the Creative Commons Attribution 4.0 International License (<http://creativecommons.org/licenses/by/4.0/>), which permits unrestricted use, distribution, and reproduction in any medium, provided you give appropriate credit to the original author(s) and the source, provide a link to the Creative Commons license, and indicate if changes were made.



References

1. Oudar J (1980) Sulfur adsorption and poisoning of metallic catalysts. *Catal Rev* 22:171–195
2. Bartholomew CH, Agrawal PK, Katzer JR (1982) Sulphur poisoning of metals. *Adv Catal* 31:135–242
3. Jackson SD, Leeming P, Grenfell J (1994) The effect of sulphur on the non-steady state reaction of propane over a platinum/alumina catalyst at 873 K. *J Catal* 150:170–176
4. Jackson SD, Leeming P, Webb G (1996) Supported metal catalysts; preparation, characterisation and function. Part IV. Study of hydrogen sulphide and carbonyl sulphide adsorption on platinum catalysts. *J Catal* 160:235–243
5. Hegde RI, White JM (1986) Chemisorption and decomposition of H₂S on Rh(100). *J Chem Phys* 90:296–300
6. Jackson SD, Willis J, McLellan GD, Webb G, Keegan MBT, Moyes RB, Simpson S, Wells PB, Whyman R (1993) Supported metal catalysts; preparation, characterisation and function. Part II. Carbon monoxide and dioxygen adsorption on platinum catalysts. *J Catal* 139:207–220
7. Jackson SD, Brandreth BJ, Winstanley D (1987) The effect of hydrogen sulphide on the adsorption and thermal desorption of carbon monoxide over rhodium catalysts. *J Chem Soc Faraday Trans 1* 83:1835–1842
8. Gillan C, Fowles M, French S, Jackson SD (2013) Ethane steam reforming over a Pt/alumina catalyst: effect of sulphur poisoning. *Ind Eng Chem Res* 52:13350–13356
9. Laosiripojana N, Assabumrungrat S (2011) Conversion of poisonous methanethiol to hydrogen-rich gas by chemisorption/reforming over nano-scale CeO₂: the use of CeO₂ as catalyst coating material. *Appl Catal B* 102:267–275
10. Konishi Y, Ichikawa M, Sachtler WMH (1987) Hydrogenation and hydroformylation with supported rhodium catalysts. Effect of adsorbed sulfur. *J Phys Chem* 91:6286–6291
11. Rufael TS, Koestner RJ, Kollin EB, Salmeron M, Gland JL (1993) Adsorption and thermal decomposition of CH₃SH on the Pt(111) surface. *Surf Sci* 297:272–285
12. Solymosi F, Pasztor M (1986) Infrared study of the effect of H₂ on CO-induced structural changes in supported Rh. *J Phys Chem* 90:5312–5317

