



**UNIVERSITY**  
*of*  
**GLASGOW**

Stott, D.I. and Berek, C. (2002) An antigen-driven B-cell response within the salivary glands of patients with Sjögren's syndrome. *Annals of the Marie Curie Fellowship Association* 2:pp. 108-116.

<http://eprints.gla.ac.uk/3598/>

# AN ANTIGEN-DRIVEN B-CELL RESPONSE WITHIN THE SALIVARY GLANDS OF PATIENTS WITH SJÖGREN'S SYNDROME

**David I. Stott<sup>\*</sup> and Claudia Berek<sup>†</sup>**

*\*Marie Curie Fellow, Dept. of Immunology, University of Glasgow, Western Infirmary, Glasgow G11 6NT, Scotland, U.K., email: d.i.stott@clinmed.gla.ac.uk;*

*†Deutsches Rheumaforschungszentrum, Schumannstrasse 21/22, D-10117 Berlin Germany.*

## ABSTRACT

Infection with a bacterium or virus induces the production of antibodies, specialised protein molecules that bind to and eliminate the microorganism. These antibodies are produced by B-cells that are stimulated by antigen (any foreign protein or carbohydrate) in the lymph nodes and spleen. During this process, they diversify their variable region genes (V-genes), encoding the antigen-binding region of the antibody, by switching on machinery that mutates the V-genes at a very high rate (somatic hypermutation). In autoimmune diseases, B-cells produce autoantibodies against self-antigens present on the patient's own tissues. Clusters of B- and T-cells are frequently found in the target organs of autoimmune diseases. The aim of the work described here was to determine whether these clusters of cells are responding to stimulation by antigen. For this purpose we investigated the B-cell response in patients with an autoimmune disease affecting the salivary and lachrymal glands. By cloning and sequencing the expressed V-genes from individual clusters of cells in the salivary glands, we were able to show that the B-cells in these clusters are undergoing clonal proliferation, somatic hypermutation and antigen selection. The presence of similar structures in the target tissues of other autoimmune diseases suggests that this is a widespread phenomenon.

**Keywords:** Sjögren's syndrome; Germinal centre; Somatic hypermutation; V-gene; Autoimmune disease.

## 1. INTRODUCTION

In order to protect the body against infection by pathogenic microorganisms, the immune system employs two specific means of defence: cytotoxic T-cells are able to recognise and kill virus infected host cells; B-cells respond by producing antibodies, protein molecules which bind specifically to their target and eliminate bacteria, viruses or other pathogens from the body. Antibodies that specifically recognise any protein, carbohydrate or other organic molecule can be produced by the immune system, which has developed a unique system for generating an enormous diversity of antibody molecules. This diversity is generated at two distinct stages of B-cell development. The first stage occurs during the development of a virgin B-cell, i.e. one that has not yet encountered antigen, from a stem cell. A large number of different antibodies are generated by variable recombination of the heavy and light chain gene segments (V, D & J)

making up the antigen-binding site of the antibody (immunoglobulin) molecule, (Fig. 1). Diversity is increased further by variation in the exact position of joining and random addition of untemplated nucleotides at the junctions. Each B-cell produces only one antibody, but many B-cells are generated, each producing antibody with a different antigen-binding site. The second stage occurs after the B-cell has been stimulated by binding of antigen to antibody molecules on its surface. The B-cell starts to divide and differentiate in clusters of cells (germinal centres) in the lymph nodes and spleen. At the same time, the rearranged V-genes start to mutate at a very high rate, generating further diversity. Mutations accumulate, especially in the complementarity regions (CDRs), which make contact with the antigen. B-cells with mutated receptors compete for binding to antigen on the surface of follicular dendritic cells (FDCs) within the germinal centre. B-cells which express antigen

receptors with high affinity are selected to differentiate into antibody-secreting plasma cells and leave the germinal centre[1-3].

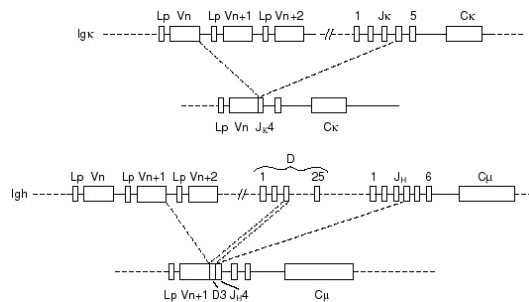

Figure 1. Diagrammatic representation of the rearrangement of immunoglobulin heavy and light chain gene segments during the differentiation of a stem cell to a virgin B-cell; (a)  $V_{\kappa}$ -gene rearrangement; (b)  $V_H$ -gene rearrangement. The coding sequences (exons) are represented by boxes and non-coding sequences (introns) are represented by lines. Exons are chosen at random and additional bases, not encoded in the DNA, are added at the junctions. This results in expression of a unique antigen receptor in every B-cell and an extremely large antibody repertoire.

Both of these processes for generation of antibody diversity are essentially stochastic, resulting in the development of B-cells with antigen receptors that recognise self-antigens, in addition to B-cells producing antibodies against foreign antigens. The former, if allowed to develop unchecked, can produce autoantibodies that attack the host's own tissues, resulting in autoimmune disease. Consequently, the immune system has to learn to discriminate between self and non-self. This distinction is learned by encounter of developing B- and T-cells with self-antigens during development, when self-reactive cells are either deleted or rendered unable to respond to self-antigen.[4]

The safeguards that ensure self/non-self discrimination fail to operate in some individuals, with the result that the immune system attacks and destroys their own tissues, causing autoimmune disease. This can take many forms, each of which involves damage to a different organ or tissue, but the reasons why the immune system fails to recognise the tissue antigens as self are unknown.[5-7] Structures resembling germinal centres are seen in the target tissues of several autoimmune diseases, including the salivary glands of patients with Sjögren's syndrome[8;9].

Sjögren's syndrome (SS) patients develop chronic inflammatory lesions in the salivary and lachrymal glands with degeneration of the glandular tissue and severely diminished secretion. This can cause infection of the eyes and mouth and these patients also have an increased incidence of B-cell lymphoma. Primary SS is not associated with other autoimmune diseases, whereas secondary SS is found in patients with systemic lupus erythematosus (SLE), rheumatoid arthritis and other autoimmune diseases. Approximately 25% of SS patients also have rheumatoid arthritis[8]. The major autoantibodies associated with SS recognise IgG (rheumatoid factor (RF)), protein antigens associated with RNA (Ro and La), salivary duct antigens [10] and  $\alpha$ -fodrin. Several of these autoantibodies appear to have pathogenic activity, including antibodies against  $\alpha$ -fodrin [11]. Anti-Ro and anti-La are believed to cause congenital heart block in the children of mothers with Sjögren's syndrome, due to transplacental passage of the antibodies which bind to fetal heart muscle [12;12-14]. Infiltrating B- and T-cells are found in the salivary, lachrymal glands, the respiratory tract, gastrointestinal tract and vagina. Clusters of B- and T-cells and numerous plasma cells, are found in the salivary glands of SS patients [8;9], which have been shown to secrete autoantibodies, including rheumatoid factor, anti-Ro and anti-La [8;15;16]. We have examined Ig V-gene expression by B-cells in these lymphoid cell clusters in order to determine whether the B-cells are undergoing antigen-driven clonal proliferation, somatic hypermutation and affinity selection *in situ*, or whether they migrate independently into the target tissue after antigen stimulation in the secondary lymphoid organs.

To answer these questions, clusters of B-cells were excised from tissue sections of salivary gland biopsies by microdissection, and their expressed Ig V-genes cloned and sequenced. Only rearranged Ig V-genes are expressed, and the rearrangement is unique in each cell, hence V-genes derived from the same clone of B-cells can be identified since they share the same V (D) and J exons and have the same sequence at the junctions. Analysis of the rearranged V-gene sequences shows that an antigen driven, germinal centre-type B cell response is taking place within the salivary glands of Sjögren's syndrome patients.

## 2. MATERIALS AND METHODS

### 2.1 Patients.

Patient BW was a 65-year-old female with primary SS; Patient SG was a 39-year-old female with secondary SS and polychondritis. Minor lip salivary glands were removed surgically as part of the normal diagnostic procedure. Immediately after removal, they were embedded in Tissue-Tek OCT embedding medium (Miles, Gießen, Germany), frozen on cardice and stored at  $-70^{\circ}\text{C}$ .

### 2.2 Immunohistochemical staining of tissue sections.

6 or 8  $\mu\text{m}$  sections were cut from the frozen salivary glands at  $-18^{\circ}\text{C}$  on a cryomicrotome (Leitz). The sections were mounted on slides and fixed in acetone. The slides were stored at  $-70^{\circ}\text{C}$  in the presence of desiccant until required. Frozen sections were stained with mouse monoclonal antibodies specific for B cells (anti-CD20, Dako), T cells (anti-CD3, Dako), follicular dendritic cells (Wue-2) and plasma cells (Wue-1) (A. Greiner, University of Würzburg), followed by rabbit anti-mouse Ig (Dako) and the alkaline phosphatase-anti-alkaline phosphatase (APAAP) complex (Dako). Immune complexes containing APAAP were detected by incubation with new fuchsin substrate (Dako) and the sections counter-stained with Mayer's haematoxylin (Sigma).

### 2.3 Microdissection of cell clusters and preparation of DNA.

Clusters of lymphoid cells were identified by staining with monoclonal antibodies as described above and excised with sterile blood lancets under sterile Scott's tap water substitute (0.35%  $\text{NaHCO}_3$ , 0.2%  $\text{MgSO}_4$ ) using an inverted microscope. The excised tissue was digested in 20  $\mu\text{l}$  proteinase K (0.7 mg/ml, Boehringer Mannheim) at  $50^{\circ}\text{C}$ ., 1h and the enzyme inactivated at  $95^{\circ}\text{C}$ , 10 min.

### 2.4 PCR amplification and cloning of rearranged Ig V-genes.

The primers and methods used for amplification and cloning of rearranged Ig V-genes have already been described [17-19] and are summarised here. All procedures prior to PCR took place in a separate laboratory from that

where PCR amplification and all subsequent steps were performed, in order to avoid contamination of samples and reagents with amplified Ig V-genes. Rearranged  $V_H$  or  $V_L$  genes were amplified from 10  $\mu\text{l}$  of DNA extracted from the cell cluster by two stage PCR. Two methods were used. In the first method, a mixture of primers corresponding to the first framework region of each of the  $V_H$  or  $V_L$  gene families was used with primers for each of the  $J_H$  or  $J_L$  exons to ensure that all rearranged  $V_H$  and  $V_L$ -genes were amplified [20]. The product was purified by agarose gel electrophoresis and reamplified using separate primers for each  $V_H$ ,  $V_K$  or  $V_\lambda$  family.

Alternatively, nested primers were used. These corresponded to the leader sequence for each  $V_H$  family and a universal  $J_H$  primer [21]. 0.5  $\mu\text{l}$  of the first PCR product was subjected to a second PCR without prior purification, using the internal primers described above. Duplicate negative control samples containing water instead of DNA were always amplified in parallel with sample DNA. These produced no detectable band after the second amplification. Amplified DNA was purified by agarose gel electrophoresis, ligated into plasmid vector pCRII and cloned using the TA cloning system (Invitrogen).

### 2.5 Sequencing and analysis of rearranged Ig V-genes.

Cloned, rearranged Ig V-genes were sequenced from both ends by a modified *Taq* sequencing protocol using digoxigenin end-labelled primers (TIB Mol Biol, Berlin), or using an automatic DNA sequencer (Applied Biosystems), as previously described [22]. The best matching germline Ig V-genes were identified by searching the human VBase Sequence Directory (Tomlinson et al., M.R.C. Centre for Protein Engineering, Cambridge, U.K.). Sequences were compared with the corresponding germline gene using the DNA Plot 1.4 programme (W. Müller, Institut für Genetik, Köln, Germany). Family trees based on V-gene sequences with identical V-D-J or V-J rearrangements were constructed by analysis of shared and unshared mutations.

### 3. RESULTS

#### 3.1 Germinal centre-like clusters of cells are present in SS salivary glands.

Tightly packed clusters of B-cells, T-cells and FDCs were identified in salivary glands of SS patients BW and SG by immunohistochemical staining. Fig. 2 shows a large cluster of cells (SG-R) around a salivary duct in a lip salivary gland of patient SG. Two patches of FDCs (Fig. 2(c)) are surrounded by B-cells (Fig. 2(a)). T-cells are mainly localised to the upper left area of the cluster (Fig. 2(b)). Many plasma cells are present in the area between two germinal centre-like clusters (Fig. 2(d), SG-L and SG-R), but very few are present within the clusters, suggesting that they have arisen by differentiation of B-cells in the clusters and migrated out. None of the cell clusters had a discernible mantle zone, normally found surrounding germinal centres in the spleen and lymph nodes. Since the mantle zone is believed to originate from the cells of the primary follicle, due to the outward expansion of B-cells in the germinal centre, this implies that the cell clusters in the salivary glands did not develop within primary follicles.

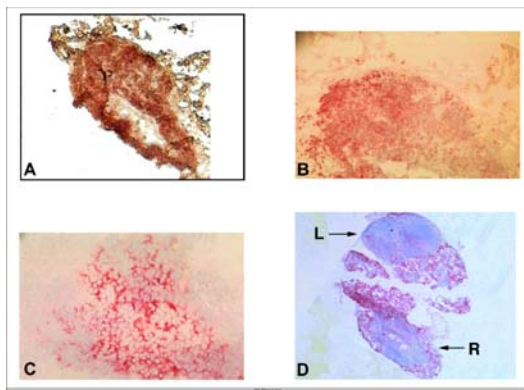

Figure 2. Germinal centre-like cluster SG-R in a lip salivary gland biopsy from patient SG. (a) SG-R stained for B-cells with anti-CD20 (x100); (b) T-cells stained with anti-CD3 (x100); (c) FDCs (x400); (d) plasma cells between the two cell clusters SG-L and SG-R (x20). Adapted from ref. [19]

#### 3.2 Ig V-gene expression in B-cell clusters.

A cluster of B-cells, T-cells and FDCs was excised from a salivary gland of patient BW and

27 rearranged Ig V-genes cloned and sequenced. Of these, five independent  $V_H$ -D-J and two  $V_L$ -J rearrangements were shared by two or more cloned genes containing base differences. The number of base differences in 4 of these sets of V-genes was above the PCR error rate of 1 base per 1200 or approximately one base change per four  $V_H$ -genes, determined by sequence analysis of rearranged germline V-genes and hybridomas [18], implying that they are derived from different members of the same B-cell clone. This is consistent with previous estimates of the PCR error rate [23-25]. Only one of these sets of V-genes (using germline gene DP-79) included sequences that could be ascribed to parental and daughter cells on the basis of shared mutations, suggesting that the parent cell had divided within the salivary gland (Fig. 3a). Two pairs of rearranged V-genes differed from their partners by six and three bases respectively, and are therefore presumably from cells that have divided and mutated, but without the parental gene we do not have direct evidence that these events took place within the cell cluster where the cells were found.

The majority of the rearranged  $V_H$ -genes isolated from two cell clusters (SG-L & SG-R) in the salivary gland biopsy of a second patient (SG) shared two sets of V, D and J exons. 5/8 of the  $V_H$ -genes from SG-L used germline V-gene VH328 with the D exon DXP'1 and  $J_H$ 5b; 21/29  $V_H$ -genes from SG-R used germline V-gene DP10 with D exon DA-1 and  $J_H$ 4b, respectively. All genes using the same  $V_H$ /D/J combination had identical junctional sequences and were therefore members of the same B-cell clone. All of the 8 remaining  $V_H$ -genes isolated from cluster SG-R used the germline gene DP65 and were non-functional rearrangements containing stop codons but had different mutation patterns. Since all functional  $V_H$ -genes from this cluster were derived from the same clone of B-cells, it seems likely that the non-functional DP-65 genes were also derived from this clone and had undergone somatic hypermutation during proliferation. Similarly, all 11  $V_\lambda$  genes isolated from cluster SG-R shared the same rearrangement of germline gene DPL16. 4 functional  $V_\kappa$  genes were isolated from this cluster; 2 of these shared the same germline gene (B3) and they contained few mutations (Table 1). Thus, it would appear that the majority of cells in this cluster are members of the same clone.

Section/ Cluster	V-gene Family	Germline V-gene	No. of Sequences Isolated	Av. No. of Mutations/ V-region	Mean R/S $\pm$ S.D.		
					Framework Region	CDRs	
82 L	VH3	V3-49	1	9	4.0	>4	
	VH4	DP-65	2	22	2.2	>6	
		VH328	5	26 $\pm$ 1.1	1.3 $\pm$ 0.13	2.3 $\pm$ 0.38	
81 R	VH1	DP-10	21	14.7 $\pm$ 1.2	1.2 $\pm$ 0.22	0.9 $\pm$ 0.19	
	VH4	DP-65†*	8				
	V $\kappa$ 1	L5	2	9	3.0	4.0	
	V $\kappa$ 1	08/018†	1				
		B3	2	1.5 $\pm$ 0.5	>1	>0.5	
		B3†	1				
	V $\kappa$ 5	B2†	1				
	V $\lambda$ 3	DPL16	10	8.6 $\pm$ 1.1	1.2 $\pm$ 0.24	>4 $\pm$ 0.6	
		DPL16†	1	10	1.0	>4	

Table 1. Rearranged, mutated Ig V-genes from cell clusters L & R in a lip salivary gland biopsy of patient SG, identified by the best matching germline V-gene. The number of sequences isolated is the number with different mutations sharing the same rearrangement. Adapted from ref. [19]

†Non-functional

\*Different rearrangement from DP-65 in cluster SG-L.

Isolation of rearranged V-genes from a single B-cell clone could be due to selection bias during the PCR amplification. That this has not occurred here is shown by the identification of multiple, independently rearranged V-genes from cluster BW, peripheral blood lymphocytes (data not shown), a pharyngeal tonsil germinal centre [26] and germinal centres in the thymus of a patient with myasthenia gravis[18] using the same protocol. The pattern of V-gene usage in the latter case closely resembles the pattern in peripheral blood lymphocytes from a healthy individual obtained independently by other research groups [24;27], confirming that there is no selection bias. Approximately 10,000 B-cells were present in each section of clusters SG-L and SG-R so, if other B-cell clones were present in significant numbers we would expect to have detected them, although we cannot rule out the possibility that another clone(s) might be present in other regions of the cell cluster. None of the V<sub>H</sub>-D-J rearrangements was present in the cells of the

neighbouring cluster, showing that B-cells had not migrated between the two clusters.

### 3.3 Somatic hypermutation of Ig V-genes in SS salivary glands.

Most of the V-genes cloned from cluster BW contained relatively few mutations, including the clonally related DP79(a) set. In contrast, all members of the two clonally related sets of V-genes from patient SG were hypermutated; range 13 - 20 mutations per V<sub>H</sub>-gene in SG-R; 24 - 27 mutations per V<sub>H</sub>-gene in SG-L; and an average of 8.6  $\pm$  1.1 mutations in the V <sub>$\lambda$</sub>  gene set from cluster SG-R (Table 1). In clusters SG-L and SG-R, we see a stepwise accumulation of mutations in V<sub>H</sub> and V <sub>$\lambda$</sub>  genes enabling us to draw genealogical trees arising from the original naïve B-cell expressing the unmutated germline gene (Fig. 3). This clearly demonstrates that the two clones developed within the salivary gland by proliferation of a common precursor accompanied by V-gene diversification through somatic hypermutation.

### 3.4 Proliferation of B-cells in the salivary glands is antigen-driven.

After clonal proliferation and somatic hypermutation, the second phase of the germinal centre response to a xenoantigen is selection of B-cells expressing high affinity receptors by a second encounter with antigen on the surface of FDCs. Deviation from random of the ratio of replacement to silent mutations (R:S) in the CDR and framework regions are regarded as evidence for antigen selection [28], although it is now accepted that there is also an inherent bias towards a high R:S ratio in the CDRs and a low R:S ratio in the framework regions as a result of a bias in the hypermutation mechanism towards certain base sequences, such as the RGYW motif [29]. Interestingly, all of the  $V_H$ -genes that were members of B-cell clones in the B-cell clusters from SS salivary glands had significantly lower than expected R:S ratios in both their CDRs and framework regions. This is against the natural bias and is clear evidence for selection against replacement mutations.

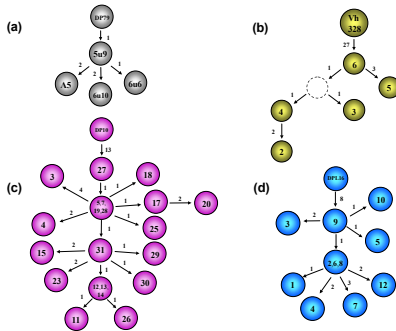

Figure 3. Genealogical trees of B-cell clones in clusters BW, SG-L and SG-R, identified by their rearranged, mutated Ig V-genes. The members of each clone share identical sequences at the V-D-J or V-J junction. (a) A B-cell clone in cluster BW expressing mutants of germline gene DP79; (b) A B-cell clone using germline gene  $V_H328$  from cluster SG-L; (c) and (d) B-cell clones using germline genes  $V_H$  DP-10 and  $V_L$  DPL16 from cluster SG-R. The top circle in each set represents the naïve B-cell expressing the unmutated germline gene. Numbers inside other circles are arbitrary numbers designating cloned genes. Numbers at the sides of the arrows indicate the minimum number of point mutations to generate a daughter cell. Dashed circles represent hypothetical intermediates. Adapted from ref. [19].

## 4. DISCUSSION

Sjögren's syndrome is an inflammatory autoimmune disease of the mucosal tissues affecting the salivary glands, lachrymal glands and mucosal tissues of the intestine. Focal infiltrates of B- and T-lymphocytes develop around the ducts; some of these foci develop into large clusters containing many B- and T-cells. Plasma cells are also visible in the surrounding glandular tissue, as shown here. We have now demonstrated that these large clusters of lymphocytes contain FDCs and have internal structure similar to that of a germinal centre, viz. segregation of areas containing B-cells, FDCs and T-cells. So far as we are aware, we are the first to demonstrate the presence of FDCs in the salivary glands of SS patients. The much smaller cluster in the salivary gland of patient BW did not show this segregation, all three cell types being distributed throughout the cell cluster; this may represent an earlier stage of germinal centre formation, an hypothesis supported by the presence of smaller, less mutated B-cell clones.

In order to determine whether a germinal centre-type reaction is taking place within these foci, we excised them by microdissection and cloned and sequenced the rearranged Ig V-genes, encoding antigen receptors, from B-cells within the clusters. The small cell cluster BW was polyclonal with many of the rearranged V-genes containing few or no mutations. One group of four  $V_H$ -genes all had identical rearrangements but only low numbers of base differences from the germline gene, albeit above the PCR error rate, suggesting that they were derived from B-cells that had divided within cluster BW.

The two large cell clusters from patient SG resemble fully developed germinal centres since all except one of the functionally rearranged  $V_H$ -genes were derived from two clones of B-cells, one in each cell cluster. The observation of large numbers of plasma cells surrounding these clusters also supports this hypothesis. Both B-cell clones in clusters SG-R and L contained a large number of mutations compared with the corresponding germline genes. Each of the two clones proliferated within the clusters from common precursor cells since a genealogical tree can be drawn for each on the basis of shared and unshared mutations (Fig. 3).

Despite the high frequency of mutation, indicative of a memory response, the low R:S ratios of mutations in the framework regions and CDRs of V<sub>H</sub>328 and DP-10 indicate that selection against replacement mutations has occurred. Low R:S ratios were also found in the CDRs of hypermutated rheumatoid factors from healthy donors [30], antibodies produced by germinal centre B-cells in synovial membranes from rheumatoid arthritis patients [17] and anti-DNA antibodies from SLE patients [31]. These results imply that antigen selection is driving the B-cell response within the salivary gland in SS and in the synovial membrane in rheumatoid arthritis. These results contrast with the high R:S ratio in the CDRs of antibodies against most xenogeneic antigens, suggesting that different selection processes may operate during the autoimmune response.

Lower than random R:S ratios in the CDRs during an autoimmune response could be due to the presence of high concentrations of autoantigen within the target tissue. B-cells expressing high affinity antigen receptors would have no selective advantage over cells expressing receptors with lower affinity. Negative selection would still be effective, however, since mutations that remove contact residues or disrupt the V-domain structure would render the antigen receptor unable to bind antigen and/or unable to signal to the B-cell, consequently, the cell would cease to divide. This is consistent with the antigen mimicry hypothesis, in which a pathogenic microorganism triggers a small number of B-cells with cross-reactive receptors for a self-antigen (e.g. SS-A). The response would be maintained by high concentrations of self-antigen presented on follicular dendritic cells in the salivary glands. Intra- and intermolecular epitope spreading would then lead to production of other autoantibodies, e.g. against SS-B and rheumatoid factor.

The origin of the parental B-cells that founded the clones proliferating within the cell clusters in the salivary glands is not known, but the low number of mutations in the DP79 clone found in cluster BW suggests that this clone arose from a naïve B-cell, whereas the clones in SG-L and SG-R, which were more heavily mutated, probably arose from memory B-cells. This is consistent with a chronic autoimmune response with continual restimulation by self-antigen. The memory B-cells may either be generated in a secondary

lymphoid organ and subsequently migrate to the salivary gland, or they may develop in the salivary gland itself, where they become activated and induced to proliferate. Our data show that a microenvironment is built up within the salivary gland that allows a germinal centre reaction to take place.

Ectopic germinal centre-like structures have been described in other autoimmune diseases, including Hashimoto's thyroiditis, autoimmune hepatitis, autoimmune uveoretinitis and cryptogenic fibrosing alveolitis, on the basis of their immunochemical staining [32-35], although evidence of a germinal centre reaction, as described here, has not yet been presented in these cases. We have demonstrated that germinal centre reactions, i.e. antigen-driven clonal proliferation of B-cells, somatic hypermutation of their Ig V-genes and antigen selection, occur in the salivary glands of Sjögren's syndrome patients. A similar response has also been described in the synovial membranes of rheumatoid and reactive arthritis patients [17;26;36;37] and in germinal centres in the thymus of myasthenia gravis patients [18]. The combination of histological and molecular evidence suggest that germinal centre-type reactions in the target tissue may be a common feature of autoimmune diseases. The knowledge that ectopic germinal centres in the target tissues are a site of local antigen stimulation in autoimmune disease implies that these could be a target for therapeutic intervention. Recent clinical trials, in which a monoclonal antibody that blocks the germinal centre response was administered to SLE patients, are a promising move in this direction (Lipsky, P., International Congress of Immunology, Stockholm, 2001).

## ACKNOWLEDGEMENTS

We wish to thank Drs. T. Dörner, T. Feist and F. Hiepe for supplying the lip salivary gland biopsies, Dr. M. Hummel for help with the sequencing. Dr. J. M. Tomlinson, Medical Research Council Centre for Protein Engineering, Cambridge, U.K. for access to the Human VBase Sequence Directory, Dr. A. Schröder for advice on techniques and Ms. G. Steinhauser for technical assistance. D. I. Stott was funded by



E.C. Training and Mobility (Marie Curie) Research Fellowship No. ERB4001 GT950115 and is a member of the Marie Curie Fellowship Association, membership no. 1435. Part of the work was funded by the MacFeat Bequest, University of Glasgow, Scotland, U.K. and the Wellcome Trust. The Deutsches Rheumaforschungszentrum is supported by the Berlin Senate for Research and Education.

## REFERENCES

1. **Kelsoe,G.**, The germinal centre: a crucible for lymphocyte selection. *Seminars in Immunol.* 1996. **8**: 179-184.
2. **Camacho,S.A., Kosco-Vilbois,M.H., and Berek,C.**, The dynamic structure of the germinal center. *Immunol.Today* 1998. **19**: 511-514.
3. **Casamayor-Palleja,M., Gulbranson-Judge,A., and MacLennan,I.C.M.**, T cells in the selection of germinal center B cells. *Chemical Immunology* 1997. **67**: 27-44.
4. **Janeway,C.A.**, How the immune system works to protect the host from infection: A personal view. *Proc.Natl.Acad.Sci.(U.S.A.)* 2001. **98**: 7461-7468.
5. **Marrack,P., Kappler,J., and Kotzin,B.L.**, Autoimmune disease: why and where it occurs. *Nature Med.* 2001. **7**: 899-905.
6. **Rose,N.R.**, Infection, mimics, and autoimmune disease. *J.Clin.Invest.* 2001. **107**: 943-944.
7. **Stevenson,F.K. and Natvig,J.B.**, Autoantibodies revealed: the role of B cells in autoimmune disease. *Immunol.Today* 2000. **20**: 296-298.
8. **Talal,N.**, Sjögren's syndrome and connective tissue diseases associated with other immunologic disorders. In **McCarty,D.J. and Knoopman,W.J.** (Eds.) *Arthritis and Allied Conditions.* Lea & Febiger, Philadelphia 1993, pp 1343-1356.
9. **Bigazzi,P.E.**, In **Bona,C., Siminovitch,K.A., Zanetti,M., and Theofilopoulos,A.N.** (Eds.) *The Molecular Pathology of Autoimmune Diseases.* Harwood, Lausanne 1993, pp 493-510.
10. **MacSween,R.N.M., Goudie,R.B., Anderson,J.R., and et al.**, Occurrence of antibody to salivary duct epithelium in Sjögren's disease, rheumatoid arthritis, and other arthritides. *Ann.Rheum.Dis.* 1967. **26**: 402-411.
11. **Haneji,N., Nakamura,T., Takio,K., Yanagi,K., Higashiyama,H., Saito,I., Noji,S., Sugino,H., and Hayashi,Y.**, Identification of  $\alpha$ -fodrin as a candidate autoantigen in primary Sjögren's syndrome. *Science* 1997. **276**: 604-607.
12. **Reichlin,M. and Scofield,R.H.**, SS-A (Ro) Autoantibodies. In **Peter,J.B. and Shoenfeld,Y.** (Eds.) *Autoantibodies.* Elsevier, Amsterdam 1996, pp 783-788.
13. **Keech,C.L., McCluskey,J., and Gordon,T.P.**, SS-B (La) Autoantibodies. In **Peter,J.B. and Shoenfeld,Y.** (Eds.) *Autoantibodies.* Elsevier, Amsterdam 1996, pp 789-797.
14. **Horsfall,A.C., Venables,P.J.W., Taylor,P.V., and Maini,R.N.**, Ro and La antigens and maternal anti-La idiotype on the surface of myocardial fibres in congenital heart block. *J.Autoimmun.* 1991. **4**: 165-176.
15. **Horsfall,A.C., Rose,L.M., and Maini,R.N.**, Autoantibody synthesis in salivary glands of Sjögren's syndrome patients. *J.Autoimmunity* 1989. **2**: 559-568.
16. **Horsfall,A.C., Venables,P.J.W., Allard,S.A., and Maini,R.N.**, Co-existent anti-La antibodies and rheumatoid factors bear distinct idiotypic markers. *Scand.J.Rheumatol.Suppl.* 1988. **75**: 84-88.
17. **Schröder,A.E., Greiner,G., Seyfert,C., and Berek,C.**, Differentiation of B cells in the nonlymphoid tissue of the synovial membrane of patients with rheumatoid arthritis. *Proc.Natl.Acad.Sci.(U.S.A.)* 1996. **93**: 221-225.
18. **Sims,G.P., Hiroyuki,S., Willcox,N., and Stott,D.I.**, Somatic Hypermutation and Selection of B Cells in Thymic Germinal Centers Responding to Acetyl Choline Receptor in Myasthenia Gravis. *J.Immunol.* 2001. **167**: 1935-1944.
19. **Stott,D.I., Hiepe,F., Hummel,M., Steinhauser,G., and Berek,C.**, Antigen-driven clonal proliferation of B cells within the target tissue of an autoimmune disease . The salivary glands of patients with Sjögren's syndrome. *J.Clin.Invest.* 1998. **102**: 938-946.
20. **Marks,J.D., Tristem,M., Karpas,A., and Winter,G.**, Oligonucleotide primers for polymerase chain reaction amplification of human immunoglobulin variable genes and design of family-specific oligonucleotide probes. *Eur.J.Immunol.* 1991. **21**: 985-991.
21. **Tomlinson,I.M., Walter,G., Marks,J.D., Llewelyn,M.B., and Winter,G.**, The repertoire of human germline V<sub>H</sub> sequences reveals about fifty groups of V<sub>H</sub> segments with different hypervariable loops. *J.Mol.Biol.* 1992. **227**: 776-798.
22. **Ziegner,M., Steinhauser,G., and Berek,C.**, Development of antibody diversity in single germinal centers: selective expansion of high affinity variants. *Eur.J.Immunol.* 1994. **24**: 2393-2400.
23. **Küppers,R., Zhao,M., Hansmann,M.-L., and Rajewsky,K.**, Tracing B cell development in human germinal centres by molecular analysis of single cells picked from histological sections. *EMBO J.* 1993. **12**: 4955-4967.
24. **Brezinschek,H.-P., Foster,S.J., Brezinschek,R.I., Dörner,T., Domiati-Saad,R., and Lipsky,P.E.**, Analysis of the human VH gene repertoire: differential effects of selection and somatic hypermutation on human peripheral CD5<sup>+</sup>/IgM<sup>+</sup> and CD5<sup>-</sup>/IgM<sup>+</sup> B cells. *J.Clin.Invest.* 1997. **99**: 2488-2501.
25. **Dörner,T., Brezinschek,H.-P., Brezinschek,R.I., Foster,S.J., Domiati-Saad,R., and Lipsky,P.E.**, Analysis of the frequency and pattern of somatic mutations within nonproductively rearranged human variable heavy chain genes. *J.Immunol.* 1997. **158**: 2779-2789.

26. **Schröder,A.E., Sieper,J., and Berek,C.,** Antigen-dependent B cell differentiation in the synovial tissue of a patient with reactive arthritis. *Journal of Molecular Medicine* 1997. **3**: 260-272.
27. **de Wildt,R.M.T., Hoet,R.M.A., van Venrooij,W.J., Tomlinson,I.M., and Winter,G.,** Analysis of heavy and light chain pairings indicates that receptor editing shapes the human antibody repertoire. *Journal of Molecular Biology* 1999. **285**: 895-901.
28. **Shlomchik,M., Litwin,S., and Weigert,M.,** The influence of somatic mutation on clonal expansion. *Prog.Immunol.* 1989. **7**: 415-423.
29. **Dörner,T., Foster,S.J., Farner,N.L., and Lipsky,P.,** Somatic hypermutation of human immunoglobulin heavy chain genes: targeting of RGYW motifs on both DNA strands. *Eur.J.Immunol.* 1998. **28**: 3384-3396.
30. **Børretzen,M., Randen,I., Zdarsky,E., Øystein,F., Natvig,J.B., and Thompson,K.M.,** Control of autoantibody affinity by selection against amino acid replacements in the complementarity-determining regions. *Proc.Natl.Acad.Sci.(U.S.A.)* 1994. **91**: 12917-12921.
31. **Diamond,B., Katz,J.B., Paul,E., Aranow,C., Lustgarten,D., and Scharff,M.D.,** The role of somatic mutation in the pathogenic anti-DNA response. *Ann.Rev.Immunol.* 1992. **10**: 731-758.
32. **Knecht,H., Saremaslani,P., and Hedinger,C.,** Immunohistological findings in Hashimoto's thyroiditis, focal lymphocytic thyroiditis and thyroiditis de Quervain. Comparative study. *Virchows Archiv - Abteilung A Pathologische Anatomie* 1981. **393**: 215-231.
33. **Willcox,N. and Vincent,A.,** Myasthenia gravis as an example of organ-specific autoimmune disease. In **Bird,G. and Calvert,J.E.** (Eds.) *B Lymphocytes in Human Disease*. Oxford University Press, Oxford 1988, pp 469-506.
34. **Mosnier,J.-F., Degott,C., Marcellin,P., Henin,D., Erlinger,S., and Benhamou,J.-P.,** The intraportal lymphoid nodule and its environment in chronic active hepatitis C: An Immunohistochemical study. *Hepatology* 1993. **17**: 366-371.
35. **Freni,M.A., Artuso,D., Gerken,G., Spanti,C., Marafioti,T., Alessi,N., Spadaro, Ajello,A., and Ferrau,O.,** Focal lymphocytic aggregates in chronic hepatitis C: Occurrence, immunohistochemical characterization, and relation to markers of autoimmunity. *Hepatology* 1995. **22**: 389-394.
36. **Berek,C. and Kim,H.J.,** B-cell activation and development within chronically inflamed synovium in rheumatoid and reactive arthritis. *Immunol.* 1997. **90** : 261-268.
37. **Kim,H.-J., Krenn,V., Steinhauser,G., and Berek,C.,** Plasma cell development in synovial germinal centers in patients with rheumatoid and reactive arthritis. *J.Immunol.* 1999. **162**: 3053-3062.