

nn 8201

674

C

**Early senescence of rice
and *Drechslera oryzae*
in the Wageningen Polder,
Surinam**

NN08201.674

A.O. Klomp

A.O. Klomp

Early senescence of rice and *Drechslera oryzae*
in the Wageningen Polder, Surinam

Proefschrift

ter verkrijging van de graad van
doctor in de landbouwwetenschappen,
op gezag van de rector magnificus,
dr.ir. J.P.H. van der Want, hoogleraar in de virologie,
in het openbaar te verdedigen
op vrijdag 11 februari 1977 des namiddags te vier uur
in de aula van de Landbouwhogeschool te Wageningen



Centre for Agricultural Publishing and Documentation

Wageningen - 1977

Abstract

Klomp, A.O., 1977. Early senescence of rice and *Drechslera oryzae* in the Wageningen Polder, Surinam. Agric.Res.Rep. (Versl.landbouwk.Onderz.) 859, ISBN 90 220 0621 2, (vii) + 97 p., 29 figs, 28 tables, 64 refs, 4 appendices, Eng. and Dutch summaries.

Also: Doctoral thesis, Wageningen.

Rice is grown in monoculture in the Wageningen Polder, Surinam, South America, which comprises 10 000 ha of heavy clay soil. Fungal diseases caused appreciable losses of the rice crop in several years. *Drechslera oryzae* van Breda de Haan was found to be the major pathogen of rice. Its most conspicuous symptoms are leaf spots. Infection by *D. oryzae* was most severe during the reproductive phase of the rice plant. During that phase, the crop also showed a number of other symptoms such as discoloration of leaves, premature ripening with sterility, root decay, and matted roots. These symptoms together are designated as 'early senescence'. Brown leaf spotting caused by *D. oryzae* is just one of the group of symptoms constituting the syndrome. Severe infection by *D. oryzae* indicates poor rice-growing conditions.

D. oryzae has the character of a perthophyte. The susceptibility of rice to infection by *D. oryzae* increases with the age of the plant. The fungus sporulates abundantly only on senescent leaves. Occurrence of epidemics is related to imbalance in development between the vegetative and the generative stages of the rice plant. This imbalance is induced by the incorporation of organic matter in the soil with tillage or the application of large amounts of nitrogen to the crop during the vegetative stage only.

Early senescence of rice in the Wageningen Polder can be prevented by good tillage, balanced application of nitrogen, breeding and selection of cultivars specially adapted to marginal growing conditions.

Control of *D. oryzae* with fungicides only takes away one of the causes of crop losses. Application of fungicides has not been economic.

This thesis will also be published as Agricultural Research Reports 859.

© Centre for Agricultural Publishing and Documentation, Wageningen, 1977.

No part of this book may be reproduced or published in any form, by print, photoprint, microfilm or any other means without written permission from the publishers.

Stellingen

1. Uit het oogpunt van landbouwplantenteelt wordt in de Wageningen Polder in Suriname rijst verbouwd onder marginale omstandigheden.

Dit proefschrift.

2. In het rijstveredelingsprogramma van de Stichting voor de Ontwikkeling van Machinale Landbouw in Suriname dienen de kruisingsprodukten in een vroeg stadium van selectie te worden getoetst onder Wageningse, of gesimuleerd Wageningse omstandigheden.

Dit proefschrift.

3. Inoculatie van kiemplanten is als methode ongeschikt om de gevoeligheid van rijst voor *Drechslera oryzae* te toetsen.

Dit proefschrift.

4. Vroege veroudering van rijst vermindert niet alleen de kwantiteit, maar ook de kwaliteit van het geoogste produkt; voor de economische bedrijfsresultaten van een verticaal geïntegreerd rijstproductiebedrijf is korrelkwaliteit minstens even belangrijk als opbrengst.

Dit proefschrift.

5. Ontwikkeling en verbetering van geïntegreerde bestrijding van ziekten en plagen in de akkerbouw is in hoge mate afhankelijk van de nauwkeurigheid waarmee het optreden van schadelijke organismen kan worden voorspeld.

Schütte, F. & R. Diercks, 1975. Möglichkeiten und Grenzen des integrierten Pflanzenschutzes im Ackerbau. Mitt. Biol. BundAnst. Ld-u.Forstw., Heft 165: 63-81.

6. De veronderstelling, dat de resistentie-ontwikkeling tegen ergosterol-biosynthese-remmers in schimmels onder praktijkomstandigheden onwaarschijnlijk is, is niet houdbaar.

Fuchs, A. & C.A. Drandarevski, 1976. The likelihood of development of resistance to systemic fungicides which inhibit ergosterol biosynthesis. Neth. J. Pl. Path. 82: 85-87.

7. Aantasting van gerst door *Helminthosporium sativum* neemt in Midden-Europa toe. Deze toename is waarschijnlijk een gevolg van toenemend gebruik van het meeldauw-fungicide ethirimol.

Saur, R. & F. Schönbeck, 1976. Untersuchungen über den Einfluss von Stickstoff und Ethirimol auf den Befall von Gerste durch *Helminthosporium sativum*. Z. PflKrankh. PflSchutz 83: 519-528.

8. In de gespecialiseerde graanteelt is de stikstofbemesting nog steeds het belangrijkste opbrengstverhogende produktiemiddel.

Sturm, H., 1976. Trends in der Pflanzenernährung, bezogen auf Stickstoff. BASF-Mitt. Landbau 2: 159-187.
Murayama, N., 1975. Productive efficiency of fertilizers in recent rice culture in Japan. Japan agric. Res. Q. 9: 79-83.

9. In de dialoog over ontwikkeling en nieuwe internationale economische orde tonen de ontwikkelde landen te weinig erkenning voor de eigen verantwoordelijkheid van de ontwikkelingslanden. De ontwikkelingslanden zouden zich meer bewust moeten zijn van hun eigen verantwoordelijkheid.

10. De materieel hoger ontwikkelde landen zien in positieve resultaten van ontwikkelingshulp een bedreiging van hun eigen bestaan.

11. Cursiveren van botanische namen in publikaties kan vervallen. De leesbaarheid en de duidelijkheid van het gestelde worden daardoor niet nadelig beïnvloed. De tijdsbesparing, vooral als deze publikaties op elektrische schrijfkopmachines voor offset-druk worden gereed gemaakt, is groot.

Proefschrift van A.O. Klomp

Early senescence of rice and *Drechslera oryzae* in the Wageningen Polder, Surinam

Curriculum vitae

De auteur behaalde in 1954 het diploma HBS-b aan het Canisius College te Nijmegen. In 1965 studeerde hij af aan de Landbouwhogeschool in de richting Tropische Landbouwplantenteelt met als studievakken tropische landbouwplantenteelt, fytopathologie, meteorologie en landhuishoudkunde van de tropen en subtropen.

Van 1965 tot 1969 was hij als promotie-assistent van de Landbouwhogeschool werkzaam op het Wageningen Project in Suriname. Van 1969 tot 1971 was hij hoofd van de Afdeling Onderzoek van de Stichting voor de Ontwikkeling van Machinale Landbouw in Suriname. Van 1971 tot 1974 was hij werkzaam op de afdeling ontwikkeling van agrochemicaliën van Shell International Chemical Company, Engeland. Sinds 1974 is hij coördinator voor de ontwikkeling van bestrijdingsmiddelen voor de landbouw bij Deutsche Shell Chemie Gesellschaft mbH, Bundesrepublik Deutschland.

Preface

This report contains the results of work that was done some years ago. A change of jobs, a change of worlds, after completing the trials prevented publication hitherto. The decision to present the results now was taken after careful re-appraisal of the state of knowledge about *Drechslera oryzae* and early senescence of rice. Although reinterpretation of some data was necessary, the body of the work could be left as it had been drafted.

Publication would not have been possible without the encouragement of Dr J.C. Zadoks whom I thank most sincerely. I also want to express my gratitude to the Foundation for the Development of Mechanized Agriculture in Surinam (SML). Ir P.G. de Boer and Mr C. Overwater, at that time director and technical co-director showed continuous interest in the work. Without their help, the necessary funds would not have been available. Many people were involved in the field trials, laboratory work and administrative duties. I am greatly indebted to Mr Doednath, the worker of the first hour, Mr Gonesh, Mr Ramdin, and Mr Soekoeh with his field staff.

Invaluable was the assistance of Ir J. Heeres and Drs M. Dassen, at that time students at the Agricultural University, Wageningen and the University of Utrecht, respectively. Sincere thanks to the director and the staff of the Agricultural Experiment Station, Paramaribo for their interest in this research.

I could not have written this thesis without the continuing support and friendship of my wife. Many thanks, Annemarie.

During my stay in Surinam I had the pleasure of living at the Wageningen Project amidst a community most critical towards its own existence and deeply involved in creating a tolerable life in a difficult environment. I thank all 'Wageningers' for their friendship. I am convinced they made and make a priceless contribution to the future of Surinam.

Many thanks to Mr W.C.T. Middelpaats and Mr F.J.J. von Planta, for drawing the figures, Mr J.C. Rigg, for correcting the English text, Mr R.J.P. Aalpol, for editing, and Mrs P. Rozendaal-Pennings for typing the manuscript.

Contents

1	<i>Introduction</i>	1
	1.1 Purpose of research	1
	1.2 Geographical description	1
	1.3 Rice production in Surinam	2
	1.4 Scope of the problem	4
	1.5 Organization and finance	4
2	<i>Thumbnail sketch of mechanized rice production in the Wageningen Polder</i>	5
	2.1 Original vegetation	5
	2.2 The soil	5
	2.3 Rice production in the Wageningen Polder	8
3	<i>Climatology of rice production in the Wageningen Polder</i>	12
	3.1 Climate and weather	12
	3.2 Relation between yield and weather	17
	3.2.1 Regression analysis of time, weather and yield	17
	3.2.2 Interpretation	19
	3.3 Discussion	21
4	<i>The host: rice crop, rice plant, and grasses</i>	22
	4.1 The collection of rice cultivars	22
	4.2 The population of rice and weeds	23
	4.3 Aerial parts of the rice plant	25
	4.3.1 Stages of development of the rice plant	27
	4.3.2 Feekes' scale for cereals	27
	4.3.3 Chang's growth stages for rice	28
	4.3.4 The Feekes scale for rice	29
	4.3.5 Rhythm of development of the rice plant	30
	4.4 Roots of the rice plant	32
	4.5 Conclusions	34

5	<i>The disease: symptoms, syndrome</i>	36
	5.1 Preliminary survey 1965-1966	36
	5.2 Symptoms on the shoot and the inflorescence	37
	5.3 Symptoms on the roots	38
	5.4 Syndrome of early senescence: a hypothesis	38
	5.5 Discussion	39
	5.6 Conclusion	40
6	<i>The fungus: Drechslera oryzae (Fungi imperfecti, Dematiaceae)</i>	41
	6.1 Isolation	41
	6.1.1 Drechslera leaf-spots	41
	6.1.2 Spore formation on the plant in the field	41
	6.1.3 Techniques of isolation	42
	6.1.4 Spore formation in pure culture	42
	6.2 Taxonomy	44
	6.2.1 Phylogenetic taxonomy	44
	6.2.2 An adventure in numerical taxonomy	45
	6.3 Spore germination	48
	6.3.1 Germination in guttate	48
	6.3.2 Effect of substrate	49
	6.4 Inoculation techniques	50
	6.4.1 Seedling inoculation	50
	6.4.2 Sheath inoculation	53
	6.4.3 Sheath inoculation of 12 rice cultivars	56
	6.5 Discussion and conclusions	57
7	<i>Epidemiology</i>	59
	7.1 Historical review	59
	7.2 Sources of inoculum	59
	7.3 Progress of brown spot disease and host-dependent factors	61
	7.4 Environmental conditions	66
	7.5 Discussion and conclusions	67

8	<i>Economic aspects of early senescence</i>	69
8.1	A field trial with organic matter, potassium, and manganese	69
8.2	Relation of yield, infection by <i>D. oryzae</i> , chlorosis and blackening of roots	78
8.3	Synthesis	78
	<i>Summary</i>	81
	<i>Samenvatting</i>	84
	<i>References</i>	87
	<i>Appendices</i>	90

1 Introduction

1.1 PURPOSE OF RESEARCH

The investigations reported in this volume were undertaken to analyse the problem of 'fungal diseases' in the Wageningen Polder, Surinam. Fungal diseases is a term used locally to indicate all diseases of leaves and inflorescences of rice collectively. According to the reports of Stichting voor de Ontwikkeling van Machinale Landbouw in Suriname (SML) these diseases caused yield losses up to 20 % in some years. Earlier attempts to solve the problem posed by fungal diseases were not successful. Application of fungicides was too expensive; breeding resistant cultivars was possible but the level of resistance achieved was seldom sufficient and the longevity of the resistance obtained was disappointingly short. Fungal diseases remained an elusive cause of crop losses.

1.2 GEOGRAPHICAL DESCRIPTION

The Republic of Surinam is part of the South American continent bordered in the north by the Atlantic Ocean, in the south by Brazil. It is the second of the three Guianas: French Guiana (east), Surinam (middle), and Guyana (west). Surinam roughly covers the square between 2° and 6° North latitude, and 54° and 58° longitude West (Fig. 1).

Topographically the country can be divided into three regions: the hilly inland, the old coastal plain, and the young coastal plain, occupying 86 %, 3 % and 10 % of the total area of $163\,265\text{ km}^2$, respectively (UN, 1974). The inland is covered with tropical rain forest, where access is difficult. The old coastal plain is partly covered by younger sediments especially alongside the rivers. The young coastal plain consists of clay, in some places covered by east-west running sand and shell ridges. Agriculture is concentrated in the young coastal plain. The main crop is rice.

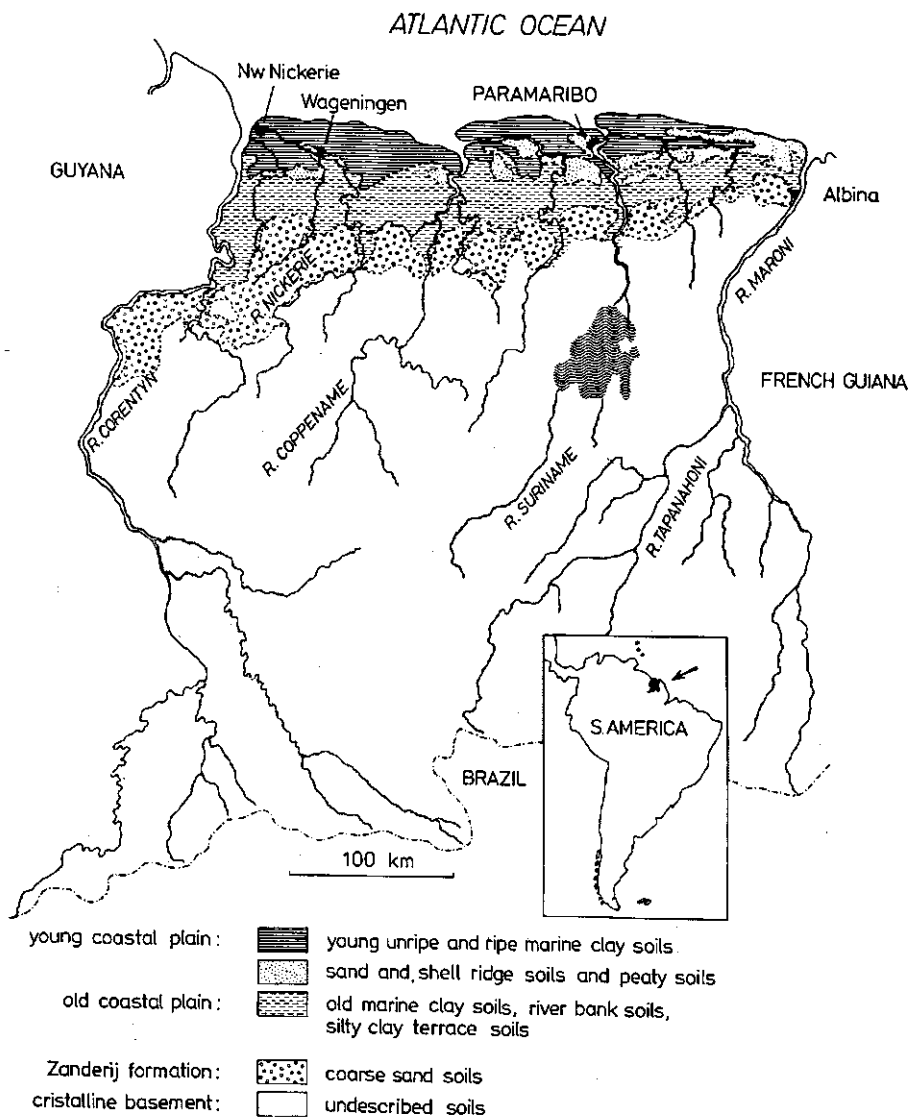

Figure 1. Surinam and its main soil types (after Scheltema, 1974).

1.3 RICE PRODUCTION IN SURINAM

Surinam has about 50 000 ha arable land. On about 30 000 ha rice is produced. Total rice production amounts to about 120 000 metric tons per year (unhusked). Until recently the condition of the irrigation works was such that rice production was only possible during the long rainy season. The irrigation system has

been improved especially in west Surinam. In a large part of the area, a second crop can be produced during the short rainy season.

The development and maintenance of an irrigation and drainage system is pre-requisite for mechanization of rice culture. The first trials in mechanized rice production date back to 1933 (van Dijk, 1940). The experience gained over the years has been used profitably for the lay-out and development of the Wageningen Project (de Wit, 1960; ten Have, 1967). The Wageningen Project is situated in the north-east of the country in the young coastal plain. It borders on the Nickerie River. The project, named after the town of Wageningen, the Netherlands, seat of the Agricultural University, comprises over 10 000 ha rice polder (Fig. 2) run as one estate by the Stichting voor de Ontwikkeling van Machinale Landbouw in Suriname (SML), in translation Foundation for the Development of Mechanized Agriculture in Suriname. SML is a non-profit semi-governmental organization responsible for reclamation of land and all aspects of production of rice from seed production to delivery of packed milled or polished rice to merchants abroad.

SML has also reclaimed land adjoining its own polder for the Surinam Government, which leases plots of 24 ha to farmers trained in the mechanized

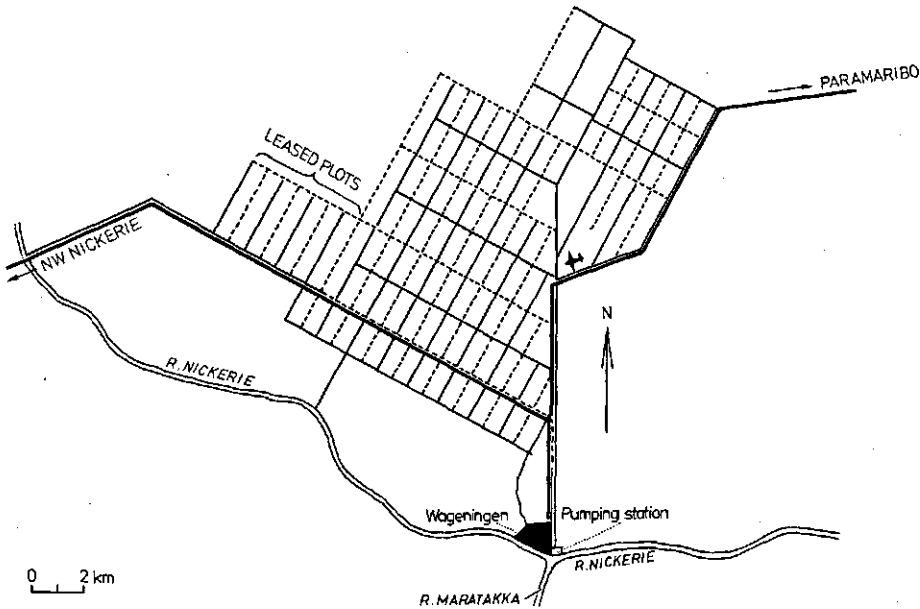

Figure 2. The Wageningen Project in Surinam. The map shows the main road Paramaribo-New Nickerie and the drainage system. Solid lines - irrigation canals. Broken lines - drainage canals.

cultivation of rice at the Wageningen Project. Close liaison exists between the Wageningen Project and its pilot scheme the Prins Bernhard Polder some 40 km westwards. The Prins Bernhard Polder has a station for breeding and selection of SML rice cultivars.

1.4 SCOPE OF THE PROBLEM

The Wageningen Project became operational in 1954. Until 1960, plant samples were sent to the Plant Protection Division of the Ministry of Agriculture, Animal Husbandry and Fisheries in Paramaribo a few times per season. From these samples, three pathogens were isolated regularly: *Cercospora oryzae* Miyake, *Pyricularia oryzae* Cavara, and *Drechslera* (*Helminthosporium*) *oryzae* Subramanian & Jain ex van Breda de Haan.

Appreciable crop losses could be associated with severe *D. oryzae* infections. In 1961, it was found that the occurrence of *D. oryzae* and certain soil conditions were related (van Beers, 1961). More specifically, it was assumed that reduction processes in flooded rice soils enhanced disease. A measure for reduction was the generation of gases in the soil and the smell of hydrogen sulfide. Introduction of new and relatively disease resistant rice cultivars caused the problem of fungal disease to subside until 1963, when losses occurred again.

At the start of the work reported here a new phytopathological survey had to be carried out. Among the many fungi found, *Drechslera* sp. was the major pathogen of rice in the Wageningen Polder. The fungus was found on all cultivars grown and caused far more infection than other pathogens.

1.5 ORGANIZATION AND FINANCE

The work was organized so that the results eventually could be presented in the form of a doctoral thesis to the Faculty of Agricultural Sciences, Agricultural University, Wageningen, the Netherlands. Scientific guidance was provided by the Laboratory of Phytopathology of the Agricultural University. The writer was offered a postgraduate assistantship by the Agricultural University on secondment to SML. Study-tours were reimbursed by SML and the Agricultural University; SML provided trial fields, laboratory facilities, labour, and transport.

2 Thumbnail sketch of mechanized rice production in the Wageningen Polder

The following paragraphs give a description of the rice cultivation as it has developed over the years 1965-1971; no significant changes in the method of cultivation took place since, except for those related to the shortening of the growth period due to new cultivars.

2.1 ORIGINAL VEGETATION AND RECLAMATION

The Wageningen Polder was set out north of the Nickerie River nearly opposite the mouth of the Maratakka river. About 100 ha of the polder area was reclaimed from marsh forest, 9000 ha from swamp forest and herbaceous swamp. Marsh is flooded in the rainy season and dry in the dry season; swamp is inundated almost permanently. The swamp forest consisted of *Erythrina glauca*, *Pterocarpus* and *Tabebuia* swamp woods and *Machaerium lunatum* scrubs. The vegetation of the brackish herbaceous swamp included *Typha* sp., *Cyperus* sp., and *Leersia hexandra*. The present rice soil had been formed under an *Avicennia* vegetation, which had been succeeded by brackish herbaceous swamp (Lindeman, 1953).

Before reclamation started the area was surrounded by dams to keep the swamp water out and drainage canals were dug. The surface water was removed by gravity drainage. Evapotranspiration by the existing vegetation promoted deep-drainage. After the soil was dry enough, the trees were poisoned with arsenite. They were pulled down, stacked, and burnt. The upper layer, consisting of organic matter, was also burnt whenever possible. The underlying clay was further prepared as rice soil.

2.2 THE SOIL

The Wageningen soil consists of a heavy clay. Within the polder substantial differences occur in soil ripening. Unripened permanently reduced clay was shallowest in the centre of the polder, reaching to 50 cm of the surface. The depth of permanently reduced soil increased gradually to 100-150 cm in the north and 200 cm in the south. Noteworthy is that the pattern of rice yields does not

coincide with the depth of ripening.

The particle size distribution of the upper 60 cm of Wageningen soil is given in Table 1. More than 83 % by mass of the soil particles were smaller than 20 μm . Table 2 summarizes some physical properties of the soil estimated at the Laboratory for Soil Mechanics, Delft, the Netherlands. Under practical conditions the permeability of the layer between 15 and 45 cm can be much higher than the values given in Table 2, depending upon the method of tillage. Wet tillage decreased vertical permeability to 0-3 mm/day ($0-3.5^{-6}$ cm/s); after dry tillage permeability ranged 8-10 mm/day ($9.3-11.6^{-6}$ cm/s). The layer 45-100 cm has a permeability of 100-200 mm/day ($1.2-2.3^{-4}$ cm/s) (Scheltema, 1974). X-ray diffraction analysis was carried out on the clay fraction twice (Table 3). The differences cannot be explained. Wageningen clay strongly swells and shrinks with changes in moisture content. The soil has a tough plastic consistency.

The Laboratory for Soil and Crop Testing, Oosterbeek, the Netherlands,

Table 1. Particle size distribution of Wageningen soil, Surinam. Data from: Royal Tropical Institute, Amsterdam, the Netherlands (1955).

Fraction	Particle size (μm)	Proportion by mass (%)
clay	<2	63 - 70
fine silt	2 - 20	20 - 30
silt	20 - 50	2 - 16
sand	>50	0 - 0.6

Table 2. Some physical properties of Wageningen soil, Surinam. Data from: Laboratory for Soil Mechanics, Delft, the Netherlands (1951).

mass density of solid phase	2.7 kg/l
mass density of whole soil	1.7 kg/l
pore volume fraction	55 - 60 %
permeability to water	10^{-7} - 10^{-8} cm/s

Table 3. Mineral composition (%) by X-ray diffraction analysis of the clay fraction of Wageningen soil, Surinam.

Royal Tropical Institute (1955)		Brinkman (1967)	
quartz	24	quartz	20
kaolin	13	kaolin	40
illite	63	illite	20
		smectiet	20

Table 4. Chemical analysis of Wageningen soil, Surinam. Data from: Laboratory for Soil and Crop Testing, Oosterbeek, the Netherlands.

Depth (cm)	P-Al nr	K ₂ O(g/kg)	MgO(g/kg)	pH(KCl)
0 - 20	6	0.23	2.359	4.8
20 - 40	4	0.27	2.673	5.4
40 - 60	7	0.32	2.641	6.0
60 - 80	10	0.37	2.502	6.5

The values are averages of 17 samples.

Table 5. Chemical analysis of Wageningen soil, Surinam. Source: Institute of Soil Fertility, Haren near Groningen, the Netherlands.

Depth (cm)	Org. matter (%)	Fe ₂ O ₃ (%)	Mn(mg/kg)	
			reducible	total
0 - 20	5.7	4.2	60	169
20 - 40	2.0	5.4	64	229
40 - 60	1.0	6.2	263	571
60 - 80	0.5	5.9	536	909

The values for organic matter and manganese are averages of 17 samples; the values for Fe₂O₃ are averages of 4 samples.

analysed the soil for its phosphate, potassium, and magnesium content. By courtesy of Dr A.J. de Groot from the Institute for Soil Fertility, Haren near Groningen, the Netherlands, soil samples were analysed for calcium carbonate, manganese, iron, and organic matter (Tables 4 and 5).

The pH of the soil increased with depth. The pH of flooded soil was slightly more than one unit higher than of moist soil. Phosphate and potassium contents increased with depth. Whether this was caused by percolation or by depletion of the top layers by the harvested crop is not known. According to the Royal Tropical Institute, Amsterdam, both phosphate and potassium were 100 % fixed by Wageningen clay. The magnesium content was high. The content of organic matter decreased rapidly with depth, indicating that most of the roots grew in the top 20 cm of the soil. The amount of manganese increased with depth. This could mean that manganese was washed out (de Groot, 1966, pers. commun.). The Fe₂O₃ content also increased with depth. In comparison with marine clays in Western Europe, the iron/manganese ratio was extremely high. Wageningen clay hardly contained any calcium.

2.3 RICE PRODUCTION IN THE WAGENINGEN POLDER

Two crops are grown each year. This is possible because there are two dry periods each year (Chap. 3) allowing ripening and harvesting of the crop and subsequent tillage of the soil under favourable dry conditions. Drainage of the soil is very difficult indeed. Therefore, rice cannot be rotated with other crops but has to be produced in monoculture.

Until 1965, three out of four fields of the Wageningen Polder were sown once a year, one out of four twice a year. If the utilization of the land is 100 % for one crop a year on all fields, the utilization before 1966 was $\frac{3}{4} \times 100 + \frac{1}{4} \times 200 = 125$ %. From then onwards it was increased gradually to 165 % in 1969 and 180 % in 1975. The utilization of the area has been pictured in Figure 3. An overlap as seen in 1965/1966 has been avoided in subsequent years by increasing the number of machines and improving management of rice production. Ratoon cropping - regrowth of the stubble after nitrogen top-dressing and reflooding - was tested, but it was not introduced because the yield was too low and the grain quality was too poor.

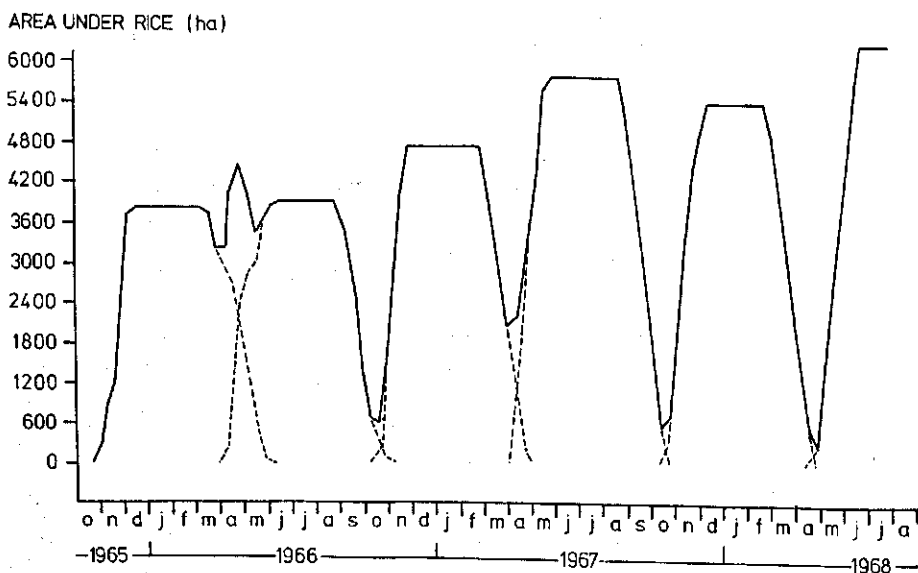

Figure 3. Utilization of the rice fields of the Wageningen Polder between 1965 and 1968. The total area under rice for a given month is indicated by the solid line. The broken lines are the continuation of the solid lines for a particular season, the crop of the foregoing season gradually being harvested, the crop of the following season being sown at the same time on fallow fields or on fields tilled shortly after harvesting the foregoing crop.

All major operations of rice production in the Wageningen Polder have been mechanized. Tillage and preparation of the seedbed were carried out with tractor mounted equipment; seed, nitrogen fertilizer, and crop protection chemicals were distributed by aircraft; the crop was harvested with track-mounted rice combines.

Different methods for tillage and seedbed preparation have been developed for various conditions of soil and weather. The following main categories can be distinguished:

dry tillage	dry seedbed preparation		
dry "	wet	"	"
wet "	wet	"	"
wet "	dry	"	"

Dry/dry A completely dry soil treatment is only possible after a period of dry weather that lasted several weeks. The method includes burning of the stubble after crushing or cutting the straw, ploughing 2-3 times with a Rome offset disk harrow, and levelling with a heavy wooden beam. This treatment results in a fine crumbly seedbed with a depth of 7-12 cm. The soil is well aerated and oxidized.

Dry/wet If ploughing does not give clods fine enough to be levelled under dry conditions, the seedbed can be prepared with a puddler after irrigation of the field. The result is a level smooth seedbed that can be sown when the mud has stiffened after drainage of the surface water.

Wet/wet This treatment is applied when proper drying of the soil is not possible through untimely rainfall. The weather usually permits burning of loose straw but cutting or crushing and subsequent burning of the stubble is not always possible. The stubble has to be worked into the irrigated soil which is treated several times with a mud roller. The soil turns into a paste, the top layer is virtually impermeable, and the content of organic matter is high.

Wet/dry Puddling followed by preparation of a dry seedbed has no practical meaning.

According to Scheltema (1974), the most economic methods of tillage and seedbed preparation are dry/dry and dry/wet because they are carried out quicker and easier than wet/wet, the efficiency of nitrogen utilization is greater, and yields are highest.

Table 6. Animal pests and weeds and their control in the Wageningen Polder, Surinam, 1965-1971. The use of pesticides was adapted since 1971 to EEC regulations

Weeks before (+) or after (-) sowing	Pest	Pesticide	Dose (kg or l/ha)	Remarks
Animal pests				
- 1	watersnails (Pomacea sp.)	pentachlorophenate- -Na 85 % a.i.	4	water depth 10 cm
+ 0 to + 3	water weevil (Helodytes sp.)	dieldrin 200 g/l a.i. e.c.	1.5-2	drainage recommended
+ 1 to + 4	leaf miners (Hydrellia sp.)	parathion-methyl 500 g/l a.i. e.c.	0.5-1	raising of waterlevel recommended
	caterpillars (Spodoptera sp.)			
+ 4 to + 15	delphacids (Sogata sp.)	parathion-methyl 500 g/l a.i. e.c.	1-1.5	
	jassids (Draculacephala sp.)	or malathion 570 g/l a.i. e.c.	1-1.5	
	brown stemborer (Diatrea sp.)	parathion-methyl 500 g/l a.i. e.c.	1-1.5	
	white stemborer (Rupela sp.)			
	brown bug (Tibraca sp.)			
	root maggots (Helodytes sp.)	lindane 200 g/l a.i. e.c.	2	
	rats (Holochoylus sp.)	coumarin baits; malariol		
+ 15 to + 20	mites (Acarina sp.)	parathion-methyl 500 g/l a.i. e.c. or malathion 570 g/l a.i. e.c.	1-2 2	
+ 10 to + 20	seed bugs (stink-bugs) (Oebalus sp.)	parathion-methyl 500 h/l a.i. e.c. or during ripening malathion 570 g/l a.i. e.c.	1 1-1.5	
	grass-hoppers (Conocephalus sp.)			
	marsh fowl (Porphyryla sp.)	no control		

Table 6. continued

Weeks before (+) or after (-) sowing	Pest	Pesticide	Dose (kg or l/ha)	Remarks
Weeds				
+ 1 to + 3	<i>Ischaemum rugosum</i> , <i>Echinochloa colonum</i> , <i>E. crus pavonis</i> , <i>Fimbristylis miliacea</i>	propanil 360 g/l a.i. e.c.	5-6	raising of waterlevel recommended
+ 3 to + 0	<i>Sphaenoclea zeylanica</i> , <i>Luziola spruceana</i> , <i>Nymphae amazona</i> , <i>Fimbristylis miliacea</i>	amine of 2,4- -dichloro phenoxy acetate 720 g/l a.i. e.c.	1.5-3	control of <i>Luziola</i> not always satisfactory

The fields are irrigated at or shortly after sowing, the moment depending upon the original moisture content. The depth of water is adjusted to plant height, leaving most of the leaf surface above water. A few days before every nitrogen application, the fields are drained. Reflooding follows 4 days later.

If necessary, fields are also drained to achieve the maximum effect of herbicides and insecticides. Final drainage follows about 1 month before harvest to allow a good drying of the soil (weather permitting) and to promote maturation of the grain.

Soaked and germinated seed is broadcast by aircraft at a rate of 80-120 kg/ha. The only fertilizer used is urea. The results of trials with potassium and phosphate fertilizers did not justify inclusion of these nutrients in the system of crop management (Chap. 8). Standard practice is application of nitrogen at Growth Stage 6 to 7 and at Stage 8 to 9 (Chap. 4). When symptoms indicate an early need for nitrogen, an extra dressing is applied at Growth Stage 3. Trials with top-dressing during filling of the grain looked promising.

Broad leaved weeds are controlled with 2,4-dichlorophenoxyacetate, grasses with propanil (Table 6). The control of animal pests in a monoculture of some 8 000-10 000 ha of rice enclosed by marsh vegetation requires special attention. The herbicides and insecticides are applied by aircraft. No strict programme is followed. Application rather depends upon infestation and the expected crop damage and yield depression. Chemical control of fungal diseases is not considered economic.

3 Climatology of rice production in the Wageningen Polder

3.1 CLIMATE AND WEATHER

Surinam has a tropical rainy climate which belongs to category V-1: 'Tropical rainy climate with or without short interruptions of the rainy season (12 to 9½ humid months); evergreen tropical rain forest and half deciduous transition wood' (Landsberg et al., 1966). In the coastal region, the average rainfall is 2000-2500 mm per year; there are about 2000 h of sunshine, and solar radiation (total over all wave lengths) amounts to $5.0-5.8 \text{ GJ m}^{-2}$ per year.

The weather in Surinam is strongly influenced by the movement and activity of the equatorial (intertropical) zone of convergence lying between the Trade Winds of the northern and southern hemispheres. This trough moves from its most southern position over Brazil starting in February/March to its most northern position above the Atlantic Ocean. Its southward movement starts in November. The trough passes Surinam in May/June and in December. These passages coincide with periods of rainy weather. Dry periods occur when the trough lies over Brazil or over the Atlantic Ocean.

This system underlies the division of the year into four seasons (Surinaamse Meteorologische Dienst, 1968):

- the short rainy season from the beginning of December till the beginning of February,
- the short dry season from the beginning of February till the end of April,
- the long rainy season from the end of April till the middle of August,
- the long dry season from the middle of August till the beginning of December.

The length of the seasons and the intensity of rainfall and sunshine much depend upon the depth of the equatorial trough. Generally its depth increases when it passes over land, and decreases by passing over the ocean. When the trough moves over land it causes the lower air layers to be sucked southwards. This air movement has a distinct influence on the weather in Surinam. During the first half-year the wind is rather strong, blowing from the north-east and bringing in the cool moist air from the ocean. The weather is relatively cool, the relative humidity is high, there are few hours of sunshine, and the cloud

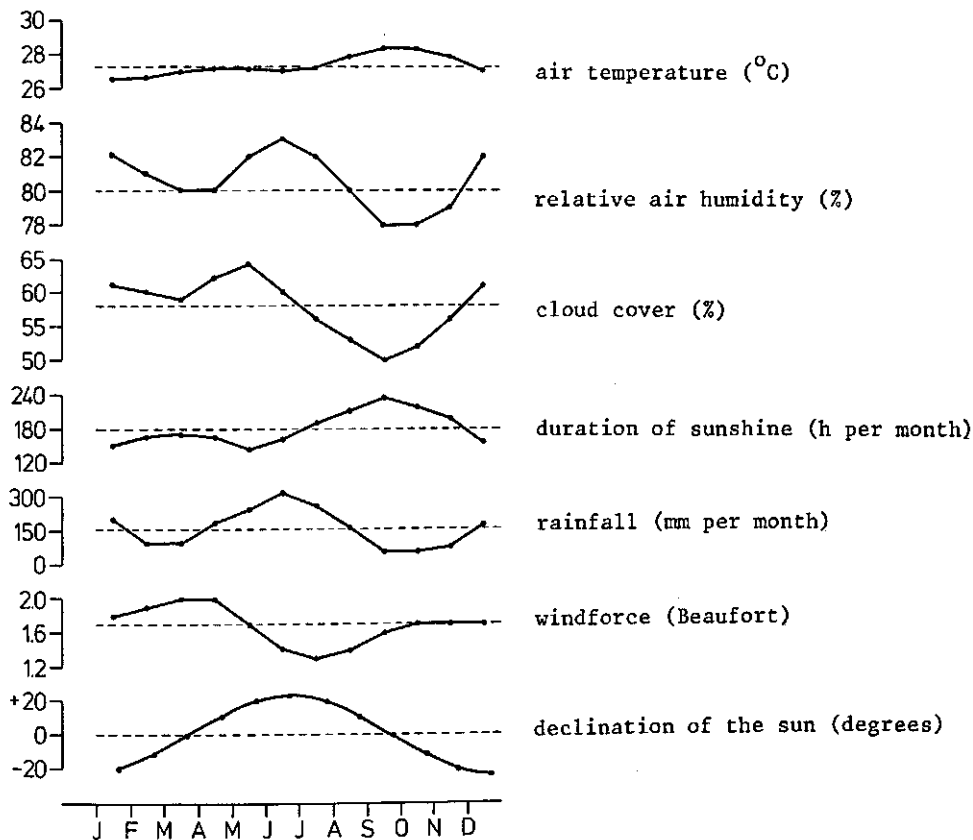

Figure 4. Some monthly averages of meteorological data from New Nickerie averaged over the years 1931-1960, based on data from the Meteorologische Dienst (Meteorological Office), Surinam.

cover is heavy. Differences between day and night temperatures are small. When the trough passes over the ocean, it is less active. The weather in the second half-year has, therefore, the following characteristics: light north-easterly wind during the day caused by a sharp warming up of the air over land; south-easterly wind during the night; many hours of sunshine; generally warmer and drier than in the first half-year (Fig. 4).

Rainfall The following analysis of the rainfall (Fig. 5) is based on data collected at the weather station in New Nickerie. The data available for the Wageningen Polder cover too short a period to allow more general interpretation. Only in September and October is there a more than 1:1 chance of a dry period of more than two consecutive weeks. The short dry season is much less pronounced. The difference between the seasons is clearly seen in the climagram (Fig. 6) drawn by the method of Walter (1958). From December to August the weather is

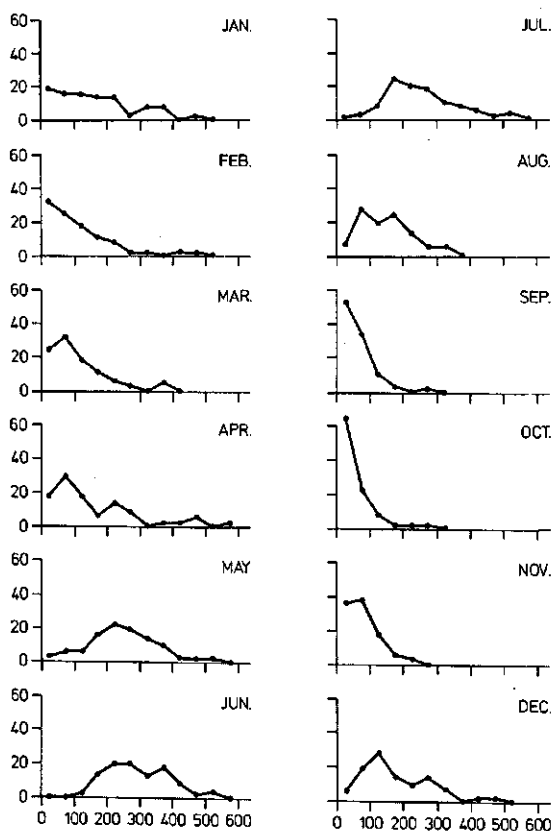

Figure 5. Frequency distribution of monthly rainfall for the weather station at New Nickerie, based on data from the Meteorologische Dienst (Meteorological Office), Surinam, for the years 1904-1967. Abscissa - rainfall in mm per month. Ordinate - relative frequency in %.

excessively wet. September, October, and November are dry. The climagram shows that the point of transition between the dry and wet months lies at about 82 mm of rainfall per month. A dry spell lasting for at least two months is desirable during ripening, harvesting, and subsequent tillage. Figure 7 shows that periods of such length occur only during the long dry season with some certainty. The short dry season often fails altogether. Curiously the amount of rain fallen during this season over the 64 years 1904-1967 has even given it the character of an excessively wet period.

Sunshine The frequency distribution of the duration of sunshine (Fig. 8) approaches that of a normal distribution whereas that for rainfall shows the binomial type (Fig. 5). The chance of a large duration of sunshine is smaller in

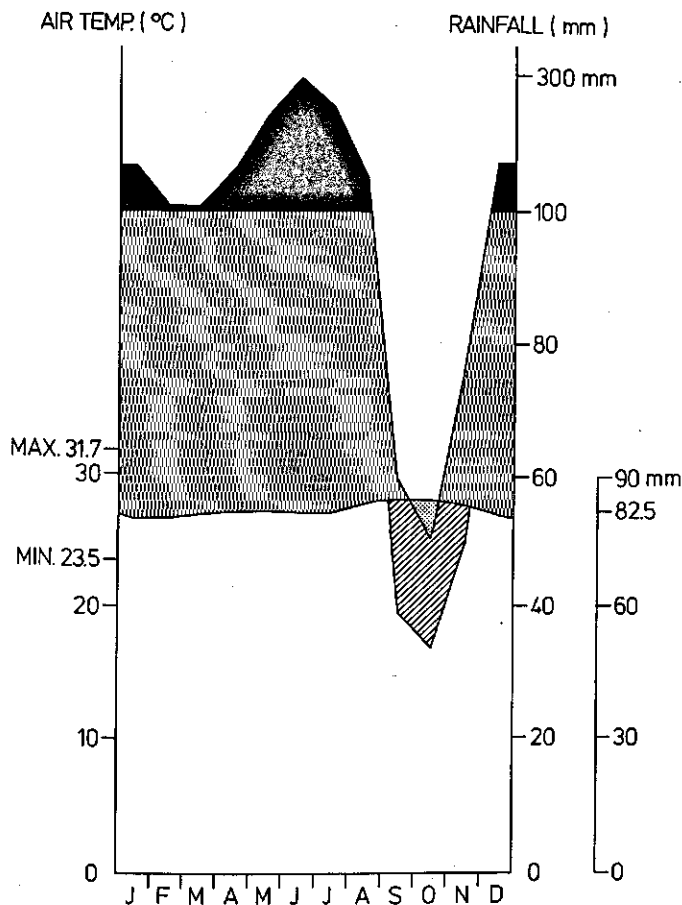

Figure 6. Climagram for New Nickerie (drawn by the method of Walter; 1958).

Abscissa - months.

Ordinate - right - rainfall in mm per month.

left - air temperature (°C)

Comment: There are two rainfall scales at the right-hand side of the climagram. These are indicated as Left and Right rainfall scales.

For rainfall up to 100 mm per month 1 °C on the temperature scale corresponds to 2 and 3 mm on the Left and Right rainfall scales, respectively. For rainfall in excess of 100 mm per month 1 °C corresponds to 0.1 mm on the Left rainfall scale. There is a period of draught when the rainfall curve descends below the temperature curve (ratio temperature : rainfall = 1 : 2). The vegetation may suffer from water shortage when the rainfall curve descends below the temperature curve on the scales with the ratio temperature : rainfall = 1 : 3 (oblique hatching). The black area indicates a 'perhumid' period.

the first half-year than in the second half-year. The sunniest months are August, September, and October.

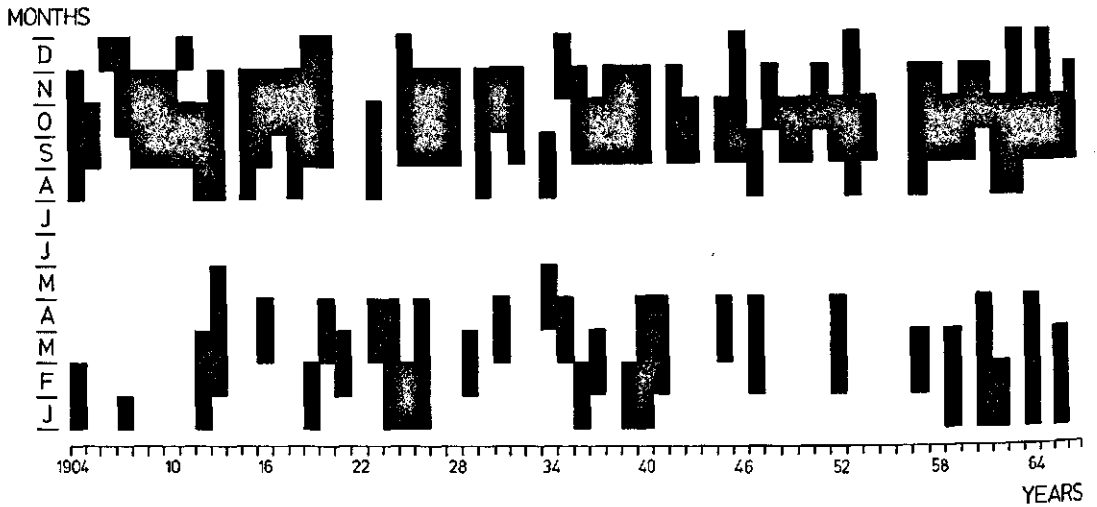

Figure 7. 'Dry' periods (black blocks) defined as periods of at least two consecutive months with rainfall less than 82.5 mm per month (based on data from the Meteorologische Dienst (Meteorological Office), Surinam, for the weather station New Nickerie). The number of black blocks in the short dry season (bottom row) is decidedly smaller than the number of black blocks in the long rainy season (top row). From the managers' point of view the short dry season is 'unreliable'.

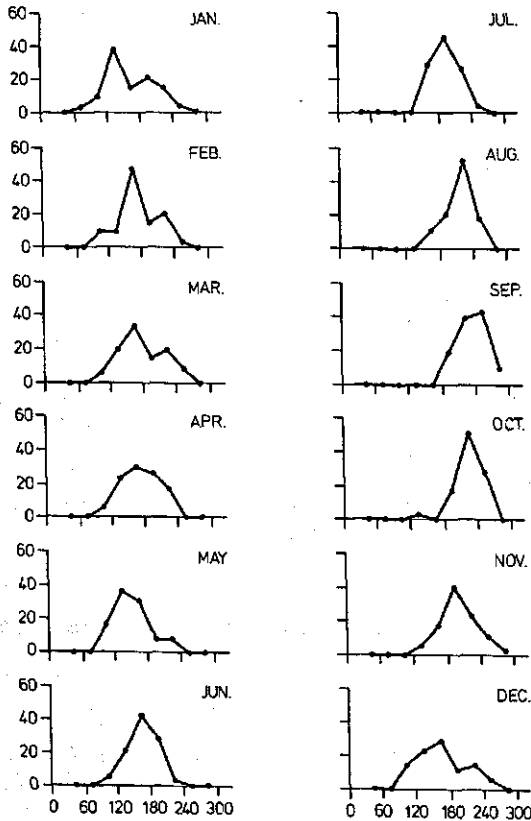

Figure 8. Frequency distribution of monthly duration of sunshine for the weather station at New Nickerie, based on data from the Meteorologische Dienst (Meteorological Office), Surinam, for the years 1931-1967. Abscissa - duration of sunshine in h per month. Ordinate - relative frequency in %.

3.2 RELATION BETWEEN YIELD AND WEATHER

Two crops are grown each year in the Wageningen Polder: (1) the spring-sown crop with tillage during the short dry season, growth period during the long rainy season, and harvest in the long dry season; (2) the autumn-sown crop with tillage in the long dry season, the growth period during the short rainy season and the harvest in the short dry season. The original plan for the Wageningen Polder was to rotate the rice crop with dry-field crops. Rice was taken as the spring-sown crop. Dry weather during harvest was emphasized. Tillage for this crop would take place in the risky short dry season. This risk was not considered important because systems for wet tillage were known. Later, yields obtained from wet-tilled fields often turned out to be lower than yields obtained from dry-tilled fields. According to de Wit (1960), dry tillage had an even greater influence on yield than dry weather during harvest. The production of crops other than rice was not feasible on the heavy poorly drainable Wageningen clay. This experience led to an increase in the area sown twice with rice. The two cropping seasons per year now have equal value. The weather tending to be somewhat more favourable during the second half-year, one could expect differences in yield between the two crops. On average, the autumn-sown crop - 3063 kg/ha - yielded less than the spring-sown crop - 3245 kg/ha - (Table 7) but the magnitude of the difference varied widely. No significant difference between the two series of yields was found with the Wilcoxon signed-ranks test for paired comparisons (Sokal & Rohlf, 1969). The non-paired comparison between the yield of the 14 spring-sown crops and the 13 autumn-sown crops by the Wilcoxon's two-sample test also indicated that differences between the two series of yields were not significant.

3.2.1 *Regression analysis of time, weather and yield*

To study the influence of weather on variation in yield, regression analysis was carried out with the following variables:

- chronological time, which is in a way a measure of experience,
- rainfall during tillage and seedbed preparation, which influences the quality of the seedbed,
- rainfall during ripening and harvest, which affects the filling of the grain,
- salt content of the irrigation water during sowing and early crop growth,
- area cropped, which measures the progress towards double cropping and thus is another indication of experience and of improved crop husbandry.

These factors were considered as independent variables in a regression

Table 7. Rice yields, rainfall during sowing and harvesting, salinity of the irrigation water and the area sown in the Wageningen Polder, Surinam, between 1956 and 1969.

Cropping season	Yield (kg/ha)	Rainfall (mm)		Conc. of Cl ⁻ in water (mg/l)	Area cropped (ha)
		during sowing	during harvest		
1956	2590	390	360	25	3979
1956/57	1501	360	216	22	1079
1957	2500	216	194	25	5819
1957/58	2663	194	518	975	1485
1958	2736	518	72	51	5897
1958/59	2603	72	368	2729	1418
1959	2451	368	273	918	5886
1959/60	2079	273	331	198	1979
1960	2631	331	208	114	5851
1960/61	3511	208	37	36	2343
1961	4255	37	317	6264	3900
1961/62	3039	317	249	490	2406
1962	3496	249	203	1332	5247
1962/63	3426	203	250	2016	3093
1963	2929	250	133	60	5348
1963/64	4411	133	82	2244	3462
1964	3767	82	224	5688	3974
1964/65	3186	224	162	1380	2834
1965	4064	162	111	1399	5552
1965/66	3301	111	208	2459	3783
1966	3337	208	327	739	4137
1966/67	3365	327	275	186	4851
1967	3671	275	144	56	5777
1967/68	3401	144	612	844	5326
1968	3749	612	223	48	6127
1968/69	3329	223	405	192	4965
1969	3258	405	151	348	6141

analysis with the yield as dependent variable. The shape of the regression curves was determined by successive graphic approximations as described by Ezekiel & Fox (1970). The data are given in Table 7. The third approximations are drawn in Figure 9. Table 8 gives a comparison between real yields and yields predicted from these curves. The unbiased standard error of the estimate is 336 kg/ha. The index of multiple correlation $I = 0.93$. Critical values for I are 0.626 for $P = 5\%$ and 0.701 for $P = 1\%$, indicating that the independent variables chosen explain most of the variability in yield. That part of the variance that is explained is expressed as the index of multiple determination $d = I^2$. In this case, $d = 0.87$.

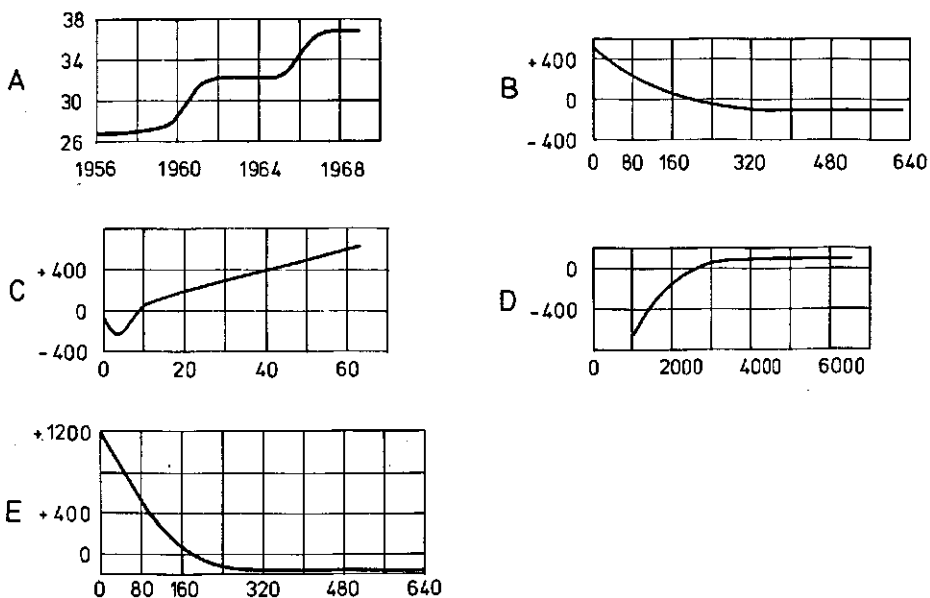

Figure 9. Relation of rice yields to time, rainfall, salinity of the irrigation water, and area sown, following the graphic approximation by the method of Ezekiel and Fox (1970).

- a: Abscissa - years.
 Ordinate - estimated yield in ka/ha x 100.
- b: Abscissa - rainfall in mm/month during the period of sowing.
 Ordinate - correction of yield estimated from the curve in a (kg/ha).
- c: Abscissa - chloride content of the irrigation water in mg Cl/l x 100.
 Ordinate - correction of yield estimated from the curve in a (kg/ha).
- d: Abscissa - area under rice in ha.
 Ordinate - correction of yield estimated from the curve in a (kg/ha).
- e: Abscissa - rainfall in mm/month during the period of harvesting.
 Ordinate - correction of yield estimated from the curve in a (kg/ha).

3.2.2 Interpretation

- During the early years of the Wageningen Polder yields increased only slowly. This situation changed with the introduction of new cultivars developed specially for mechanized rice production. Another important yield increase was achieved during 1966 and 1967 through significant improvement in crop management.
- The more rainfall during tillage the lower the yield. When rainfall surpassed 300 mm during the three months considered, yields were at the minimum.
- Yield is inversely proportional to rainfall in the final stages of ripening and during harvest. It is difficult to understand why rainfall itself should reduce yield. The relation between rainfall and duration of sunshine may offer some

Table 8. Real vs. estimated rice yields in the Wageningen Polder, Surinam (method of estimation see text).

Cropping season	(1)Real yields (kg/ha)	(2)Predicted yields (kg/ha)	(1)-(2) (kg/ha)	$[(1)-(2)] / (2)$ (%)
1956	2590	2408	182	8
1956/57	1501	1763	- 262	- 15
1957	2500	2578	- 78	- 3
1957/58	2663	2188	475	22
1958	2736	3118	- 382	- 12
1958/59	2603	2658	- 55	- 2
1959	2451	2613	- 162	- 6
1959/60	2079	2118	- 39	- 2
1960	2631	2553	78	3
1960/61	3511	3678	- 167	- 5
1961	4255	4073	182	5
1961/62	3039	2753	286	10
1962	3496	3268	228	7
1962/63	3426	3308	118	4
1963	2929	3258	- 329	- 10
1963/64	4411	4078	333	8
1963	3767	3978	- 211	- 5
1964/65	3186	3368	- 182	- 6
1965	4064	3768	296	8
1965/66	3301	3678	- 377	- 10
1966	3337	3298	39	1
1966/67	3365	3188	177	6
1967	3671	3633	38	1
1967/68	3401	3688	- 278	- 8
1968	3749	3423	326	10
1968/69	3329	3328	1	0
1969	3258	3488	- 230	- 7

explanation. The relation was calculated with monthly averages from 1931 to 1960 for the New Nickerie synoptic weather station. A measure of the relation is Kendall's coefficient of rank correlation (Table 9). Rainfall and duration of sunshine are negatively and significantly related except in January and July. More rain during ripening and harvest, therefore, means less sunshine. Sunshine has a positive influence on ripening (Matsushima, 1967).

- The increase in concentration of chloride in the irrigation water to about 0.25 g/litre caused a marked reduction in yield. This yield loss diminished with increasing salinity of the water. From 1 g/litre upwards yield even increased. Water with such high chloride concentration is not used for irrigation, sowing is postponed. Increase in salinity beyond 1 g/litre should be interpreted as drought, a condition ideal for dry tillage.

Table 9. Relation between the rainfall and the duration of sunshine for New Nickerie between 1931 and 1960; Kendall's coefficient of rank correlation τ .

Month	τ	Student's t	Probability of t arising by chance (both tails)
January	- 0.15	- 1.19	0.23
February	- 0.31	- 2.39	0.02
March	- 0.41	- 3.18	0.001
April	- 0.33	- 2.58	0.01
May	- 0.36	- 2.76	0.01
June	- 0.27	- 2.11	0.03
July	- 0.14	- 1.09	0.28
August	- 0.30	- 2.31	0.02
September	- 0.46	- 3.59	0.0003
October	- 0.28	- 2.16	0.03
November	- 0.48	- 3.75	0.0002
December	- 0.42	- 3.24	0.001

- Yields increased with increasing utilization of the land, in other words yields increased with experience in and quality of crop husbandry.

3.3 DISCUSSION

Factors in the history of the Wageningen Polder, the quality of irrigation water, rainfall during tillage, and lack of sunshine during maturation and harvest explain 87 % of the variance in rice yield. A certain minimum yield seems to be guaranteed under all but extremely bad conditions. It could well be that this adaptation to growing conditions is rooted in the primitive, nature-selected cultivars used for breeding. It seems logical that selection of new cultivars must be directed to independence of adverse soil and weather conditions.

4 The host: rice crop, rice plant and grasses

This chapter is a collection of subjects that together give a picture of the host. The host comprises more than individual rice plants. Attention must also be given to the rice crop and to grasses. After an introduction on the rice cultivars that were used for trials (section 4.1), the vegetation in and around the Wageningen Polder is described (section 4.2). Sections 4.3 and 4.4 give a phenological description of the rice plant.

4.1 THE COLLECTION OF RICE CULTIVARS

When this research started, the following SML cultivars were grown in the Wageningen Polder: Magali, Temerin, Alupi, Apura, Galibi, and Kapuri. Apart from Galibi all these cultivars were closely related (Fig. 10). This number of cultivars was regarded as too small and the differences between them insufficient to gain an insight into the relation between disease progress, cultivars, and environmental conditions. The collection therefore was enlarged with cultivars issued by the International Rice Research Institute (IRRI) under the Uniform Blast Nursery Programme (Appendix A).

SML cultivars are released by the Department of Plant Breeding of SML established in the Prins Bernhard Polder, New Nickerie. SML cultivars have been developed specifically for mechanized production of rice; their straw is stiff, the grains do not shed easily, the cultivars respond moderately to nitrogen. The leaves are erect except the flag-leaf; mutual shading is, therefore, minimized. The cultivars belong to growth type A 4 of Snellen van Vollenhoven (Broekhuizen, 1961). The grains are extra long and dry cooking.

The cultivars for the Uniform Blast Nursery Programme were collected to study the physiological specialization of *Pyricularia oryzae* Cav. in blast nurseries laid out to a design developed by Ou (1965), with cropping as for upland rice (without flooding). However, it was decided not to use this system for the study of *Drechslera oryzae*, but to grow the cultivars in the normal way. In the first season, the small amount of seed available was sown in plots of 1.5 m^2 . With seed from the first harvest, the plots were enlarged to 3 m^2 in the second

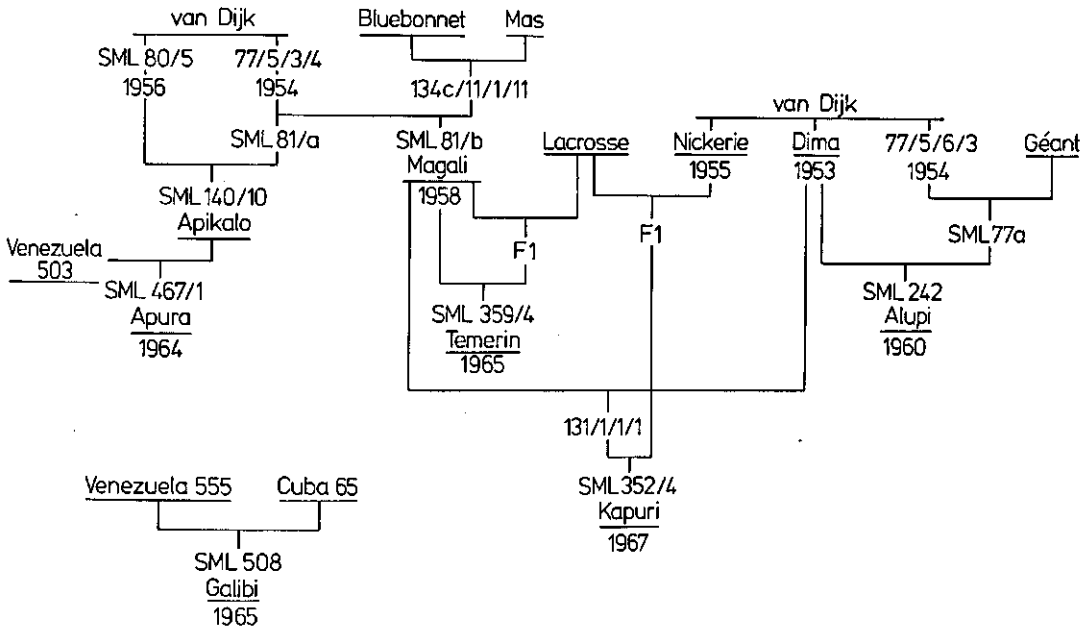

Figure 10. Pedigree of cultivars of the Foundation for Development of Mechanized Agriculture in Surinam (SML) released between 1954 and 1967 (Van Den Bogaert, pers. commun. 1969).

and third season. The collection consisted of many plant types, which were not studied individually except for their rhythm of development (Section 4.3).

4.2 THE POPULATION OF RICE AND WEEDS

In the humid tropics, the development of the vegetation is not much inhibited by weather. A dry or cold period during which most crops die down is unknown. Intervals in growth are primarily a result of human interference.

As a result of irregular tillage, low soft as well as high hard patches occur in seedbeds. In these places, the germinated seeds do not take root because they rot in deep water or desiccate on the dry spots. *Nymphoides humboldtianum* (H.B.K.) O.K. and *Sphenoclea zeylanica* Gaertn. are often found where the crop is thin. High spots are often covered with *Jussieua* spp. The grasses *Ischaemum rugosum* Salisb., *Echinochloa colonum* (L.) Link, and *E. crus-pavonis* (H.B.K.) Schult. compete for nutrients and space with young rice plants. These grasses are controlled early in the season (Chapt. 2) and disappear by the time the leaf canopy of the crop has closed. The weed problem of sown fields is of local and occasional importance only. In the Wageningen Polder, rice is always present. The crop of one season overlaps with the next (Fig. 3). Wind-borne pathogens of

Table 10. Vegetation of fallow fields in the Wageningen Polder, Surinam.

	Cover (%)	Presence (%)
GRAMINEAE		
<i>Oryza sativa</i> L. (self-sown rice) and red rice	46	95
<i>Echinochloa crus-galli</i> (H.B.K.) Schult.	9	60
<i>Ischaemum rugosum</i> Salisb.	5	35
<i>Echinochloa colonum</i> (L.) Link	3	35
<i>Luziola spruceana</i> Benth. ex Doell.	1	10
<i>Paspalum conjugatum</i> Berg.	1	5
<i>Leptochloa scabra</i> Nees	+	35
<i>Hymenachne amplexicaulis</i> (Rudge) Nees	+	10
<i>Eriochloa punctata</i> (L.) Desv. ex Hamilton	+	5
Total	65	
CYPERACEAE		
<i>Fimbristylis miliacea</i> Vahl	19	90
<i>Torulinium ferax</i> Urb.	+	40
<i>Picreus polystachyus</i> Beauv.	+	5
<i>Cyperus articulatus</i> L.	+	5
Total	19	
OTHERS		
<i>Sphenoclea zeylanica</i> Gaertn. (Campanulaceae)	6	60
<i>Jussiaea</i> sp. (Onagraceae)	5	95
Ferns	3	35
<i>Nymphoides humboldtianum</i> (H.B.K.) O.K. (Menyanthaceae)	3	25
<i>Physalis angulata</i> L. (Solanaceae)	+	25
<i>Caperonia palustris</i> (L.) St. Hill. (Euphorbiaceae)	+	10
<i>Aeschynomene sensitiva</i> Sw. (Papilionaceae)	+	10
<i>Thalia geniculata</i> L. (Maranthaceae)	+	10
<i>Crotalaria quinquefolia</i> (Papilionaceae)	+	5
Total	17	

+ = << 1 %
For method of calculation see Section 4.2.

rice, therefore, always find new material to infect and do not depend on alternate hosts to overwinter.

The drainage of fields that remain fallow for six months leaves much to be desired. The soil is saturated most of the time. The vegetation is profuse and mainly consists of rice and grasses. Red rice and its crosses with the SML cultivars have an ideal opportunity for development during a fallow period. A survey of the composition of the vegetation on fallow fields is given in Table 10.

The cover and presence of the different species are calculated by the method of Dirven et al. (1960). On each of 24 fallow fields a plot of 10 x 10 m was

pegged out on a representative part. Of each plant species within the plot, the number of plants was noted twice at an interval of 2 months. The presence of a species was expressed as a percentage indicating the number of plots where the species occurred relative to the total number of plots. The cover of a species was indicated by a ranking number. The species most frequently occurring was ranked 3, less frequent species 2, 1 or 0. Cover was then calculated by adding the rankings over the 24 plots and dividing them by the aggregate total. The most important species on fallow fields was rice. The grasses minus rice, the sedges, and the broad-leaved weeds occur in equal proportions.

The composition of the vegetation on dams which occupy 2-3 % of the area of the Wageningen Polder was calculated in the same way as the composition on fallow fields. It was examined in 12 plots of 10 x 10 m. The number of species occurring is larger on dams than on fallow fields. However, the number of species with a high percentage cover is smaller. The dams are covered largely by grasses (Table 11).

The Wageningen Polder is surrounded on all sides by the natural vegetation of the coastal area. For a description of this vegetation, see Lindeman (1953). Considered over a longer period, the composition of this vegetation is constant. The most important changes are with fires that destroy the shading trees thereby promoting the growth of grasses and other low vegetation.

The Wageningen Polder can be regarded as one unit of cultivated area within a vast area with swamp vegetation. Within that system, no regular significant changes in the population of plants are observed. Within the polder, local variations in the pattern of vegetation occur. However, these variations are not important for dispersal and survival of wind-borne leaf-infecting pathogens of rice. The weather only changes within a narrow range. An overwintering phase necessary to survive long dry or cold periods is not required. Inoculum for the infection of young plants on recently sown fields is always present.

4.3 AERIAL PARTS OF THE RICE PLANT

A system of well defined descriptions of the growth stages of the host facilitates phytopathological field observations. The intervals between the stages should not last too long for a plant with a 'normal' growth period. The stages should be easily discernable in the field. A codification of the stages allows statistical manipulations. Scales of growth stages that meet the stated requirements are Feekes' scale (1941) originally developed for wheat but also applicable to other

Table 11. Vegetation on dams between rice fields in the Wageningen Polder, Surinam.

	Cover (%)	Presence (%)
GRAMINEAE		
<i>Paspalum conjugatum</i> Berg.	40	100
<i>Leptochloa scabra</i> Nees	26	75
<i>Hymenachne amplexicaulis</i> (Rudge) Nees	10	94
<i>Eriochloa punctata</i> (L.) Desv. ex Hamilton	7	56
<i>Cynodon dactylon</i> (L.) Pers.	7	38
<i>Paspalum vaginatum</i> Swartz	4	25
<i>Ischaemum rugosum</i> Salisb.	+	37
<i>Leersia hexandra</i> Sw.	+	37
<i>Eleusine indica</i> (L.) Gaertn.	+	37
<i>Oryza sativa</i> L. and red rice	+	31
<i>Echinochloa colonum</i> (L.) Link	+	31
<i>Panicum mertensii</i> Roth.	+	13
<i>Panicum pilosum</i> Swartz	+	13
<i>Echinochloa crus-gavonis</i> (H.B.K.) Schult.	+	13
<i>Luziola spruceana</i> Bent. ex Doell.	+	6
Total	94	
CYPERACEAE		
<i>Torulinium ferax</i> Urb.	+	63
<i>Fimbristylis miliacea</i> Vahl.	+	44
<i>Cyperus articulatus</i> L.	+	31
<i>Cyperus giganteus</i> Vahl.	+	6
Total	+	
OTHERS		
<i>Physalis angulata</i> L. (Solanaceae)	3	31
<i>Jussieua</i> sp. (Onagraceae)	1	50
<i>Polygonum acuminatum</i> H.B.K. (Polygonaceae)	1	25
<i>Caperonia palustris</i> (L.) St. Hill. (Euphorbiaceae)	+	44
<i>Aeschynomene sensitiva</i> Sw. (Papilionaceae)	+	44
<i>Phaseolus</i> sp. (Papilionaceae)	+	38
<i>Sphenoclea zeylanica</i> Gaertn. (Campanulaceae)	+	38
<i>Montrichardia aborescens</i> Schott. (Araceae)	+	31
<i>Thalia geniculata</i> L. (Maranthaceae)	+	25
Amaranthaceae	+	19
<i>Crotalaria quinquefolia</i> (Papilionaceae)	+	13
Ferns	+	13
Compositae	+	13
<i>Acnida cuspidata</i> Bert. ex Spreng. (Amaranthaceae)	+	6
<i>Canna glauca</i> L. (Cannaceae)	+	6
<i>Melochia lanceolata</i> Benth. (Sterculiaceae)	+	6
Total	5	

+ = << 1 %

For method of calculation see Section 4.2.

cereals, the scale for rice designed by Chang (1968), and the decimal code compiled by Zadoks et al. (1974).

4.3.1 *Stages of development of the rice plant*

According to Tanaka (1965), the growth period of rice can be divided into four 'phases':

- The active vegetative phase, from transplanting to maximum tillering. During this phase, the number of stems and the weight of the straw increase.
- The vegetative lag phase, from maximum tillering to panicle initiation. The number of stems decreases and the length and weight of the straw increase less rapidly than in the active vegetative phase.
- The reproductive phase, from panicle initiation to flowering. During that phase the panicle primordia develop. Length and weight of straw increase more rapidly.
- The ripening phase, from flowering to harvesting. The weight of the panicle increases rapidly. The weight of the straw decreases.

This division refers to transplanted rice. The term 'active vegetative phase' can, however, also be used for the period between sowing and transplanting. The division can be maintained for direct sown rice. The length of the phases depends upon the type of cultivar and the environmental conditions. Tanaka states that, for cultivars with a growth period shorter than 130 days, the active vegetative phase and the reproductive phase overlap; those cultivars have no vegetative lag phase. Cultivars with a growth period longer than 130 days have a vegetative lag phase increasing with total growth period.

4.3.2 *Feekes' scale for cereals*

Feekes originally developed his scale to codify the growth stages of wheat. Large (1954) amended the scale for oats, barley, and rye (Table 12). Stages 1-10 give a description of the vegetative development of the cereal plant. Stages 1, 2, and 3 refer to tillering; from Stage 4 onwards, the main stem is considered. The stage of maximum tillering is not mentioned. Flowering is induced during Stage 5. Stages 6-10.5 together describe the reproductive phase. From Stage 10.5.1 on, the main stem is ripening.

Table 12. Feekes' scale for growth stages in cereals (wheat, oats, barley, rye), amended by Large (1954).

Stage	
1	One shoot (number of leaves can be added) = 'brairding'.
2	Beginning of tillering.
3	Tillers formed, leaves often twisted spirally. In some varieties of winter wheats, plants may be 'creeping' or prostrate.
4	Beginning of the erection of the pseudostem, leaf sheaths beginning to lengthen.
5	Pseudo-stem (formed by sheaths of leaves) strongly erected.
6	First node of stem visible at base of shoot.
7	Second node of stem formed, next-to-last leaf just visible.
8	Last leaf visible, but still rolled up, ear beginning to swell.
9	Ligule of last leaf just visible.
10	Sheath of last leaf completely grown out, ear swollen but not yet visible.
10.1	First ears just visible (awns just showing in barley, ear escaping through split of sheaths in wheat or oats).
10.2	Quarter of heading process completed.
10.3	Half of heading process completed.
10.4	Three-quarters of heading process completed.
10.5	All ears out of sheath.
10.5.1	Beginning of flowering (wheat).
10.5.2	Flowering complete to top of ear.
10.5.3	Flowering over at base of ear.
10.5.4	Flowering over, kernel watery ripe.
11.1	Milky ripe.
11.2	Mealy ripe, contents of kernel soft but dry.
11.3	Kernel hard (difficult to divide by thumb-nail).
11.4	Ripe for cutting. Straw dead.

4.3.3 *Chang's growth stages for rice*

Chang (1968) divided vegetative growth into 4 stages (Table 13): Stages 0, 1, and 3 do follow the normal development of the rice plant, Stage 2 is inserted to indicate the stagnation after transplanting. Stages 4 to 6 characterize the reproductive phase. The beginning of that phase is marked by panicle initiation, which cannot be seen with the naked eye. Macroscopic characteristics that accompany panicle initiation are difficult to determine. The leaf number index used by Matsushima (1967) is reliable but requires frequent, very precise observation that is usually impossible under practical conditions.

Chang's scale is less detailed than Feekes' scale. The 'vegetative lag phase', which may last several weeks for cultivars with a long growth period, is not indicated. The time before heading is divided into 5 stages (4 for direct-sown rice).

Table 13. Growth stages of the rice plant by Chang (1968).

Code

80-120 days

- 0 Germination stage: from seeding to the emergence of coleoptile from the soil.
- 1 Seedling stage: from emergence of the coleoptile to the appearance of the 5th leaf (counting the bladeless primary leaf as the first leaf) in seedbed.
- 2 Transplanting and recovery stage: from uprooting of seedlings from seedbed to full recovery following transplanting.
- 3 Tillering stage: from appearance of first tiller to panicle initiation (invisible to the eyes).

35 days

- 4 Elongation and booting stage: from panicle initiation to full development of panicle inside flag leaf sheath.
- 5 Heading stage: from first appearance of panicle tip out of the flag leaf sheath to more than 90 % panicle emergence.
- 6 Flowering stage: first flowering to completion of flowering on panicles.

25-35 days

- 7 Milky stage: caryopsis watery to milky.
- 8 Dough stage: caryopsis in soft dough to hard dough forms.
- 9 Maturation stage: ripening of terminal spikelets to more than 90 % of the grains are fully ripened (i.e. the caryopses are fully developed in size, hard, clear and free from greenish tint).
- 10 Over-ripened stage: straw is dead; over-ripened spikelets shatter from panicle.

Specification with second number is possible e.g.:

- 1.0 coleoptile
 - 1.1 primary leaf
 - 1.2 second leaf
- 3.1 first primary tiller
- 3.6 secondary tillers
- 3.8 tertiary tillers
- etc.

In Feekes' scale, this period is divided into 10 stages. The principle of the Feekes' scale seems useful for rice too. Adaptations are, however, necessary.

4.3.4 *The Feekes scale for rice*

The description of Stages 1 and 2 is valid for rice. The spiralling of the leaves is less obvious for rice than it is for wheat. The leaves of many cultivars do not spiral at all. The description of Stage 3 should therefore be restricted to: 'a number of stems formed'. The extension of the pseudostem precedes elongation of internodes of the rice plant. Stages 4 and 5 have less overlap with Stages 6

and 7 than in other cereals. Elongation of the internodes begins towards the end of Stage 5. An internode does not elongate before the leaf on top of it has completed its growth (Kerling, 1948). According to Bunting & Drennan (1966), elongation of the internodes starts after the induction of flowering.

Observation of the collection of cultivars showed that the duration of Stage 7 was closely correlated with the duration of the total vegetation period. The nodes are not visible though they can be felt in most cases inside the loose leaf-sheaths. During Stage 8, the flag leaf becomes visible. The panicle enlarges rapidly. In Stage 9, the ligula and the auricles of the flag leaf are just visible. That stage is known as the 'opposite auricle stage', the auricles of the flag leaf and the last but one leaf facing each other. According to Matsushima (1967), the panicle is then at the stage of most active reduction division.

During Stages 10 and 10.1, rice follows the pattern of other cereals. Between Stages 10.2 and 10.5.4 there are fundamental differences. In wheat, flowers positioned at the bottom of the ear open first, the flowers at the top open last. Rice flowers open from the top of the panicle downwards. As soon as the first flowers appear from the sheath of the flag leaf, they open. For rice, Stages 10.5.1 to 10.5.4, therefore, coincide with Stages 10.2 to 10.5. The description of flowering has to be changed accordingly. After flowering the development of rice again follows the pattern of other cereals. Usually the crop is harvested before the straw dies. This part of the description of Stage 11.4 can be omitted.

The above comments can be built into the Feekes' scale without changing it fundamentally (Table 14). The reproductive stage and the ripening stage can be recognized clearly in this scale. The active growth stage and the vegetative lag stage cannot be found as such. However, the phenological approach to development of the rice plant has the merit that the characteristics of both stages can be clearly observed. The stages of the Feekes' scale can be observed on any cultivar regardless of the duration of the growing period.

4.3.5 *Rhythm of development of the rice plant*

Both the date and the growth stage of rice were noted for all observations made in field trials. The relation between these two variables indicates the rhythm of development of the rice plant. If the numbers of the Feekes' scale are treated as ranking units, they can be represented graphically against time (Fig. 11). The development of cultivars with a short growing period follows a sigmoid curve. An increase in growing period causes the gradient of the curves to decline until

Table 14. Feekes' scale of growth stages adapted to rice.

Stage	
1	One shoot (number of leaves can be added).
2	Beginning of tillering.
3	Some tillers formed (number of tillers can be added).
4	Beginning of elongation of pseudostem; leaf sheaths beginning to lengthen.
5	Pseudostem formed by sheaths of leaves strongly elongated.
6	First node can be felt at base of main shoot as local thickening of pseudostem.
7	Second node can be felt.
8	Flag-leaf visible but still rolled up.
9	'Opposite auricle stage': ligule of flag leaf just visible.
10	Sheath of flag leaf completely expanded, panicle swollen but not yet visible.
10.1	First panicles just visible.
10.2	Quarter of heading completed.
10.3	Half of heading completed.
10.4	Three-quarters of heading completed.
10.5	All panicles out of sheaths.
10.5.1	Beginning of flowering at top of panicle.
10.5.2	Flowering to base of panicle.
10.5.3	Flowering over at top of panicle.
10.5.4	Flowering over.
11.1	Milky ripe.
11.2	Mealy ripe, contents of kernel soft but dry.
11.3	Kernel hard, difficult to divide by thumb nail.
11.4	Ripe for cutting.

Stages 6 to 7. From then on, the gradient is the same as for cultivars with a short growing period. Several cultivars did not produce seed within one growing season, others did not even develop an inflorescence. For these cultivars the curves flatten abruptly.

The curves can be transformed by the following 'stratagem'; the general validity of this transformation has not been investigated. The codes 11.1 to 11.4 are replaced by 10.6 to 10.9. The scale is thought to be built out of real numbers 1.0 to 10.9. These numbers are plotted on a scale with units X where $f(X) = 1 - \lg(11-X)$. This transformation achieves that the regression of the growth stages on time can be represented graphically by means of two intersecting straight lines. The point of intersection lies between Stages 6 and 7. Figure 12 clearly shows that differences in the growing period between cultivars are largely determined by differences between Stages 1 and 7. Thereafter development proceeds at roughly the same pace in all cultivars.

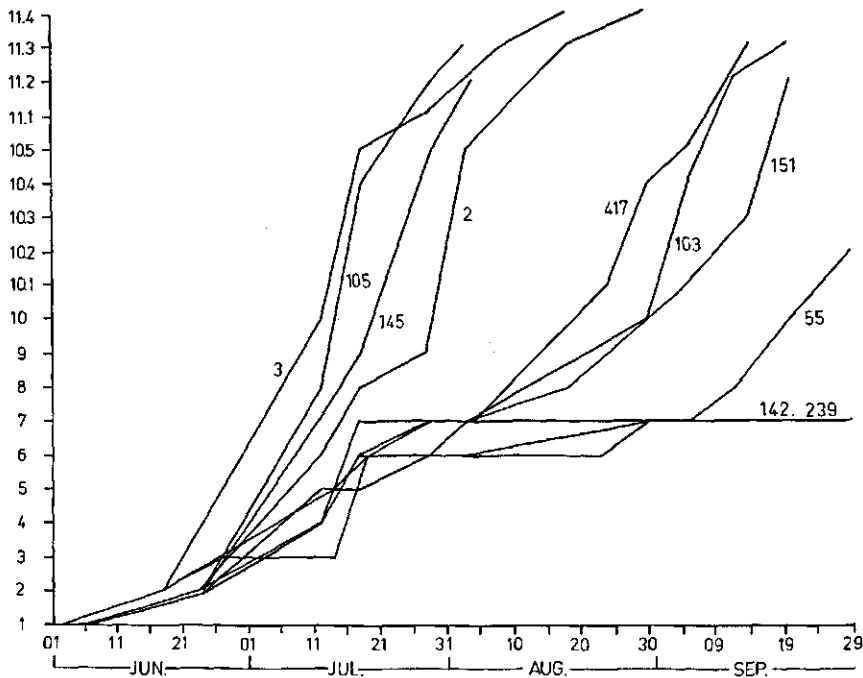

Figure 11. Rhythm of development in rice plants.
 Abscissa - period of observation.
 Ordinate - growth stages plotted on a linear scale.
 Numbers indicate rice cultivars listed in Appendix A.

The growing period of rice is determined by the duration of Stages 1-7. This observation is in agreement with those of Perumal (1963) and Tanaka (1965). According to these authors the growing period mainly depends upon the duration of the vegetative lag phase. The reproductive phase was of equal duration for all cultivars they investigated; differences in duration of the ripening phase were small.

The growing period of the SML cultivars grown between 1965 and 1971 was 135-145 days, according to season. The growing period also varied slightly from field to field, especially Stages 6 and 7. The stage of panicle initiation seems to depend somewhat upon environmental conditions (Matsushima, 1967; Matsubayashi, 1965).

4.4 ROOTS OF THE RICE PLANT

The age of rice roots can be assessed by root colour and by length of that part of the root that branches and forms side roots. Inada (1967) designed a code for

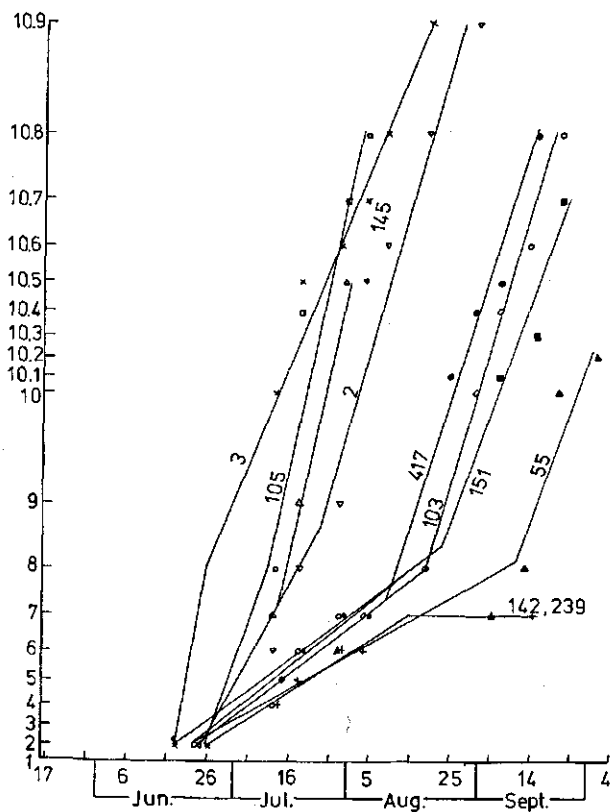

Figure 12. Rhythm of development in rice plants.
 Abscissa - period of observation.
 Ordinate - growth stages plotted on a logarithmic scale.
 Numbers indicate rice cultivars listed in Appendix A.

the development of rice roots based upon these characteristics (Table 15). The length of the branching part of the roots increases with age. Young roots are milky white, the basal parts of the older roots turn brown, and later black. Old roots have a deep dark-brown colour, they are stringy and somewhat translucent. A rice plant that develops normally forms new roots until Stage 7. At that time the root system consists of the main root with side roots and adventitious roots formed at the basal nodes of the stem.

The threadlike translucent appearance of old roots is the result from lysis of cortical cells. Rice roots have cortical oblitogenic air cavities that are connected with the aerial parts of the plant supplying the roots with oxygen in an anaerobic environment (van Raalte, 1941). In young roots, these cavities are separated by parenchymatous tissue; in older roots, this tissue has disappeared completely.

Table 15. Standard classification of rice roots according to Inada (1967).

Class	Rootlets	Colour of the roots	Age
I	none	Milky white	 Young ↑ ↓ Old
II	Seen at basal half of a root	Basal: yellow to pale brown Tip: milky white	
III ⁻	Seen in whole parts except for 2-5 cm at root tip	Basal: brown to reddish. Tip: milky white	
III ⁺	Ditto	Ditto, but blackened part: less than 1/3 of the surface	
III ⁺⁺	Ditto	Ditto, but blackened part: 1/3-2/3 of the surface	
III ⁺⁺⁺	Ditto	Ditto, but blackened part: more than 2/3 of the surface	
IV	Seen up to tip, having fallen off at basal part	Deep or dark brown, faded, and semitransparent	Old

Most roots are contained in the upper 20 cm of the soil, but roots have been found to a depth of at least 70 cm. In the Wageningen Polder, the adventitious roots often form a dense mat just under and sometimes also above the soil surface. This mat of roots is formed mainly after Stage 7, and is discussed further in Chapter 5.

The contribution of old roots to maintenance and growth of the assimilating part of the plant is smaller than the contribution of young roots (Inada, 1967). Until 1 month before ripening, more than 50 % of the root system consists of young roots. This proportion decreases rapidly from then on. The root system has to be kept in good condition and must be renewed continuously. If part of the system does not function properly it is replaced. A superficial mat of roots is thought to compensate for insufficient activity of the deeper roots (Bergman, 1959; Yamada, 1959; Takijima, 1963; Strickland, 1968). The mat of roots plays an important role in the nutrition of the rice plant in later growth.

4.5 CONCLUSIONS

The Wageningen Polder is surrounded by swamp vegetation on all sides. Within the polder, a considerable area is covered continuously with rice; changes in the population of rice have the character of half yearly shifts between sown and

fallow fields; self-seeded rice is the most important 'weed'. In the Wageningen Polder inoculum of *Drechslera oryzae* is ever present.

The development of the rice plant can be well described by an amended Feekes' scale. That scale can be considered as an universal scale for phenological description of cereals.

The variation in growing period between cultivars is mainly caused by differences in the duration of the vegetative phase, especially the vegetative lag-phase.

The development of rice roots can be described by the system created by Inada (1967). The rice plant may form a mat of roots. This phenomenon is related to malfunction of deeper roots.

5 The disease: symptoms, syndrome

5.1 PRELIMINARY SURVEY 1965-1966

All rice cultivars of the autumn-sown crop of 1965 showed symptoms of infection by *Drechslera oryzae* (van Breda de Haan) Subramanian & Jain. The cultivars Magali Tapuripa and Apikalo were susceptible also to *Cercospora oryzae* Miyake. Tapuripa and Apikalo were so heavily infected that cropping was discontinued, the area under Magali was decreased. The importance of narrow brown leaf-spot caused by *C. oryzae* was thus reduced to a sub-economic level. In some areas of the polder, the crop was infected by *Pyricularia oryzae* Cavara. In 1966, symptoms of the stackburn disease caused by *Alternaria* (*Trichoconis*) *padwickii* (Ganguly) M.B. Ellis were observed on all cultivars. In subsequent years, this disease was found only sporadically. At some sites groups of 5-10 plants were infected by *Entyloma oryzae* H. & P. Sydow. This disease never spread. False smut caused by *Ustilagoidea virens* (Cooke) Takahashi was only of local importance. *Nigrospora* sp., *Alternaria* sp., *Curvularia* sp., and *Fusarium* sp. grew on wilting leaves. *Fusarium* sp. was sometimes isolated from shrunken nodes.

The following fungi were isolated from leaf sheaths: *Corticium sasakii* (Shirai) Matsumoto, *Rhizoctonia* sp., *Ophiobolus* sp., *Pyrenochaeta* sp., *Leptosphaeria salvinii* Cattaneo, and probably *Helminthosporium sigmoideum* var. *irregulare* Cralley & Tullis. Infection by *Drechslera oryzae*, *Cercospora oryzae* or *Pyricularia oryzae* caused browning of panicle bases. Pricks by the bug *Oebalus poecilus* Dal. caused brown spots on glumes. Within and around these spots, *Fusarium* sp., *Alternaria* sp., *Drechslera oryzae*, and *Cercospora oryzae* were observed.

During the survey, none of the pathogens caused an epidemic leading to serious damage to the crop. There was no evidence of virus diseases, insect pests, or nematodes causing abundant leaf spot (compare van Hoof et al., 1962). Quantitative assessment showed that brown spot caused by *D. oryzae* was the most important disease. Its symptoms are described in following paragraphs.

In the Wageningen Polder, the rice crop did not develop as vigorously as the crops in other parts of the Nickerie District, notably in the Prins Bernhard Polder. This phenomenon is also described.

5.2 SYMPTOMS ON THE SHOOT AND THE INFLORESCENCE

Discoloration of leaves During Stages 6 to 7, the tips of older leaves of the rice plant turned yellow. The midribs occasionally remained green longer than the blades; otherwise the centre of the leaf blades browned first. During and after flowering, the older leaves discoloured and withered completely within a short time. The younger leaves also turned yellow from the tip downwards. In some fields, the crop showed a reddish-brown glow after Stages 8 to 9, whereas a normal crop would remain green until Stage 10.5. Yields from discoloured crops were low. Discoloration and early senescence of leaves is not a characteristic of SML cultivars as such and outside the Wageningen Polder this phenomenon was observed less often.

Leaf spots During development of the leaf spots caused by *D. oryzae* four successive stages can be recognized:

1. very small brown spots ('pinpoints');
2. brown spots of diameter 1-2 mm and a light brown margin;
3. oval spots with a small greyish-brown centre and a brown margin, some of these spots surrounded by a yellow halo; a dark-brown point can often be observed in the necrotic centre of the lesion;
4. oval lesions 3-4 mm long, a large necrotic centre, brown margin, sometimes surrounded by a yellow halo; the necrotic centre with one or several dark-brown points.

In some cultivars the centre of the spots did not die but remained dark-brown and turgid. The lesions did not coalesce. Their development was restricted by the midrib, not by smaller veins. The type of lesion was the same for leaf blades and leaf sheaths. Invariably, *D. oryzae* could be isolated from these spots.

Symptoms on the panicle Early senescence of leaves induced premature ripening of the crop 1-2 weeks earlier than normal. The panicles of such a crop were small; 20-100 % sterility occurred. Some panicles did not emerge fully from the sheath of the flag leaf. The spikelets remaining upright were reminiscent of 'straight head disease' (Ou, 1972). The panicle base was often brown as a result of infection by *D. oryzae*. The fungus could be isolated from small roundish dark brown spots on the glumes. Exceptionally the panicles were completely covered with dark spores.

5.3 SYMPTOMS ON THE ROOTS

Root decay Discoloration and early senescence of the green parts of the rice plant was accompanied by root decay. The roots turned dark-brown to black prematurely, the stele was surrounded by a shrivelled exodermis. Plants with decayed root systems could be pulled up easily. Presumably these roots were hardly active.

Local blackening of roots On physiologically young roots, local blackening was observed. The exodermis showed a black band a few millimetres wide. This band was found on all roots of a plant at about the same height. There seemed to be a horizon of root discoloration over a larger area without discoloration of the soil. Sometimes there were two or three horizons. Above and below the bands the roots were turgescient white or light rusty brown. Later the black parts of the exodermis shrivelled. Some roots appeared to be cut off at the black band. Sometimes white healthy-looking side-roots branched from these cut ends.

To observe the local blackening, a tube (length 30 cm, diameter 10 cm) was placed over a plant and pressed into the soil. After digging it up, the soil cylinder containing the root system was cut into segments. One or several narrow deep black bands were observed on all roots 1-2 cm under the root base. Directly below the root base, the remnants of the seed and the surrounding roots were deep-black over a zone of 5 mm. The soil between the roots did not show abnormal discoloration.

Matted roots In some fields, the plants formed white fleshy roots in the upper few centimetres of the soil or above the soil floating in the irrigation water. These roots formed a thick dense mat supporting a man for a moment before breaking to let his foot down onto the mud beneath. The matted roots were formed when the deeper-lying roots turned black and the leaves discoloured. During formation of these roots, the crop recovered, the leaves became greener, and growth resumed.

5.4 SYNDROME OF EARLY SENESCENCE: A HYPOTHESIS

The symptoms described occur during the reproductive phase of the rice plant, from Stage 6 or 7 on. The rice crop in the Wageningen Polder suffers from early and accelerated senescence. Premature ripening of the grain and sterility must be regarded as symptoms of a later phase of disease characterized in earlier stage by discoloration of the leaves and by decay of roots. Infection by

D. oryzae could be considered one of the group of symptoms constituting the syndrome of early senescence. The total effect of the disease is not immediate death of the plant, but rather accelerated completion of its life cycle. The severity of the disease can be measured in terms of yield depression.

5.5 DISCUSSION

In the Wageningen Polder, the syndrome of early senescence was recorded for the first time in 1956. A report by Stubbs & de Wit (1957) reads in translation: 'In that season, the crop showed rank growth at many sites. The leaves were densely spotted reddish-brown. *Leptochloa* grass distributed all through the crop served also as a source of the disease. In some cases, growth stopped altogether. These symptoms occurred over an area of about 200 ha. The other part of the crop showed good growth until shortly before flowering. A good yield was expected. Just before or after flowering, the crop turned gray. The appearance was different from the normal reddish-brown of the leaves. It rather indicated a gradual deterioration.'

This report also mentions that many panicles did not emerge completely or rotted, or grains did not fill. In panicles that emerged, many flowers remained sterile. The root systems of those plants developed poorly. *Drechslera oryzae* was isolated from samples of plants sent to the Landbouwproefstation (Agricultural Experimental Station) at Paramaribo.

A similar syndrome is known in Japan as 'akiochi' which means 'decline in autumn', indicating that the crop shows good development during the first - vegetative - part of the growing season, followed by a decline in the second - reproductive - part. Akiochi is regarded as a nutritional disorder occurring on 'degraded rice soils' of a low nutritional status, which are difficult to drain or have a high content of organic matter. The decline in the rice plant is accompanied by infection by *D. oryzae*, which is considered to be an indicator of poor growing conditions (Baba & Harada, 1954). From a survey conducted throughout Asia, Tanaka & Yoshida (1970) concluded that akiochi is not restricted to Japan but also occurs in other countries, being associated primarily with unbalanced crop nutrition or with sulfide toxicity. Reduced activity of the root system may result in early senescence of leaves. The rice plant compensates for this malfunction by forming a superficial mat of secondary roots (Bergmann, 1959; Takajima, 1963; Okajima, 1965; Strickland, 1968). According to Alberda (1953), these roots facilitate transport of oxygen to the deeper parts of the root system. Later in the season, the superficial roots contribute more to the

nutrition of the plant than the deeper older roots (Yamada, 1959).

Blackening of the roots may be caused by a high concentration of iron sulfide or black reduction products of iron hydroxides at the transition zone between the oxidized upper few centimetres of the soil and the layer that is reduced throughout the period of flooding (Ponnamperuma, pers. commun., 1972). Whether it is iron sulfide or hydroxide that causes blackening depends upon the concentration of sulfur in the soil. Content of sulfate in Wageningen soils varies between 0 and 400 mg/kg. A relation between depth and sulfur content could not be demonstrated (de Wit, 1960).

Older senescent leaves are more susceptible to infection by *D. oryzae* than young actively growing leaves (Padmanabhan & Ganguly, 1954). Infection, therefore, increases towards the end of the growing season even under normal growing conditions. Early senescence leads to a longer period of high susceptibility and thus to more infection at maturity.

Adverse weather like heavy rainfall and lack of sunshine especially in the second half of the season slow down anabolic processes and increase susceptibility to disease. According to Padmanabhan (1973), an accumulation of the factors led to a ruinous epidemic of *D. oryzae* in Bengal in 1942. However severe epidemics are exceptional. Normally rice shows only moderate susceptibility without clear-cut differences between cultivars. This susceptibility varies with physical conditions and nutritional status of the soil.

5.6 CONCLUSION

In conclusion it appears that the term 'syndrome of early senescence' adequately describes the aggregate of symptoms characterizing the disease of rice in the Wageningen Polder. The syndrome shows a high degree of similarity to 'akiochi' known from Japan and other rice growing areas in Asia. Akiochi is associated with unbalanced crop nutrition or with sulfide toxicity. It is hypothesized that the syndrome of early senescence of rice in the Wageningen Polder too is related to unbalanced crop nutrition, infection by *D. oryzae* merely indicating poor growing conditions.

6 The fungus: *Drechslera oryzae* (Fungi imperfecti, Dematiaceae)

6.1 ISOLATION

6.1.1 *Drechslera leaf-spots*

The fungus was isolated from all types of rice-leaf spots as described in section 5.2, and also from leaf spots on the following weeds: *Ischaemum rugosum* Salisb., *Echinochloa colonum* (L.) Link, *E. crus-pavonis* (H.B.K.) Schult., *Paspalum conjugatum* Berg., *Leptochloa scabra* Nees, *Cynodon dactylon* (L.) Pers., *Torulinium ferax* Urb., and *Cyperus giganteus* Vahl.

On most weeds, the leaf spots were oval with a necrotic centre, a brown margin, and sometimes a yellow halo. Their size roughly equalled that of the spots on rice leaves. The dark brown points characterizing the leaf-spots on rice were missing. The lesions on the leaves of *Ischaemum rugosum* were dark chocolate-brown without a necrotic centre; the margins were indistinct and a yellow halo was observed occasionally. The oval spots on leaves of *Cynodon dactylon* remained small; the necrotic centre was surrounded by a dark brown margin, sometimes with a yellow halo.

6.1.2 *Spore formation on the plant in the field*

The presence of mycelium in the leaf spots could be demonstrated by colouring with cotton blue. On turgescient green leaves 1-5 spores per lesion were formed at a time. The spores only grew in the centre of a spot. No spores were formed in small spots on green leaves. Conidia were formed in abundance on chlorotic leaves. They could easily be discerned from the spores of saprophytes.

On weeds sporulation was usually profuse, occurring in the lesions on green as well as chlorotic leaves. The number of *D. oryzae* spores observed was largest in the morning and during wet weather.

6.1.3 Techniques of isolation

Lesions of Classes 3 and 4 were selected, cut out, and incubated on moist filter-paper in a closed Petri dish. They sporulated abundantly only when the leaf tissue around the spots had turned yellow. Sporulation could be accelerated by applying a few drops of aqueous chloroform 4 % to the filter-paper. Conidiphores were then formed in large numbers in the zone around the spots; in the centre of the lesions, only few spores were present. The fungus was isolated by picking up one or more spores with a brush moistened by tap water or with a needle dipped in water agar. The spores were transferred to a thin plate of water-agar. They germinated after a few hours at room temperature (25 to 30 °C). The fungus spread over the plate as a thin mycelial mat. The purity of the isolate was checked under the microscope. After about a week, hyphal tips from the outer part of the mycelium were transferred to sterile nutrient media in conical flasks. To purify an isolate one transfer usually sufficed.

6.1.4 Spore formation in pure culture

Nutrient media were tested to find the most suitable for production of large amounts of spores needed for inoculation of plants.

Spore production on agars An isolate of *D. oryzae* was transferred to nutrient media in conical flasks placed in diffuse daylight supplemented by continuous lighting from two Philips 40 W 35 RS fluorescent tubular lamps (TL) hanging 50 cm above the flasks. After incubation, the spores were collected as follows. Sterility was discontinued; 15 ml distilled water and 15 glass beads were brought into the flask, which was then shaken for 1 min. The suspension of spores and mycelial fragments was poured over into a small bottle. The flask was rinsed with 5 or 10 ml distilled water to remove the last spores and mycelial fragments, and these were also transferred to the bottle. The spore concentration was measured in a haemocytometer. The results of an experiment with different culture media and different incubation periods are given in Figure 13. Spore yields were estimated at weekly intervals. The number of spores harvested decreased after some time. The best results were with malt agar incubated for 2 weeks. In another experiment, the influence of the type of light was examined. To initiate good growth of the fungus, additional light from fluorescent tubular lamps was needed. Diffuse daylight supplemented by continuous fluorescent light during two weeks gave best results (see Table 16). The number of spores collected could be increased 6 to 7

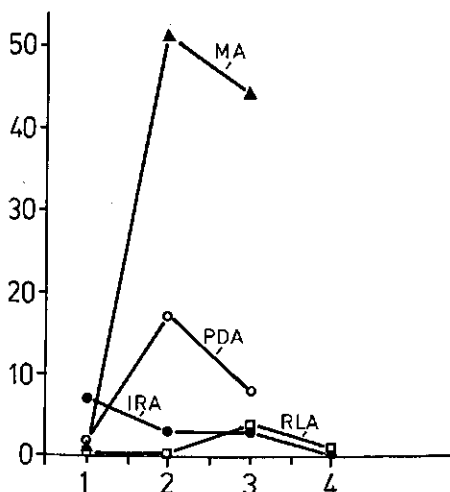

Figure 13. Spore production of *Drechslera oryzae* on agars. Relation between spores harvested and incubation period on various culture media.

Abscissa - incubation period in weeks.
 Ordinate - no. of spores per μ l sporesuspension.
 MA = Malt agar
 PDA = Potato decoction agar
 IRA = *Ischaemum rugosum* decoction agar
 RLA = Rice leaves decoction agar

Table 16. Spore production of *Drechslera oryzae* on agars. Influence of the type and the duration of lighting during incubation.

Treatment	Spores/ μ l
TL 1 wk	2
TL 2 wk	50
TL 1 wk; full daylight 1 wk	2
TL 1 wk; diffuse daylight 1 wk	27

TL = diffuse daylight supplemented by continuous lighting from two Philips 40 W 35 RS fluorescent tubular lamps.

fold when after the first harvest the flasks were placed under fluorescent light again for another 2 days to obtain a second harvest.

Spore production on rice grains; dry spores Large numbers of spores can be grown on sterilized 'cargo rice', i.e. dehusked unpolished rice. The following technique was developed for this purpose. Conical flasks of 100 ml were quarter-filled with cargo rice and 25 ml distilled water. This medium was sterilized for 20 min at

110 °C. After cooling it was inoculated with hyphal tips from a water-agar culture. After incubation for 1 week under continuous fluorescent light, the sterility was discontinued and the grains, now penetrated by mycelium, were placed on wet filter-paper in closed Petri dishes. Spores were formed after 30-48 h. To suppress mycelial growth the grains were transferred to dry filter-paper sterilized over a flame. Spores were collected with a brush or needle. Spores were abundant. They were somewhat larger than those formed on agar media.

6.2 TAXONOMY

6.2.1 *Phylogenetic taxonomy*

Drechslera has dark sporophores and dark spores, and thus belongs to the Dematiaceae. The phylogenetic taxonomy of these fungi is given by Ellis (1971), who follows the revision of the genus *Helminthosporium* by Subramanian & Jain (1966). Formerly *Drechslera oryzae* was known as *Helminthosporium oryzae*, a name still used by many authors.

Helminthosporium oryzae was described for the first time, though incompletely, by van Breda de Haan in 1900. A better description was published in 1901 by Hori (Tanaka, 1922). However, for reasons of priority, (van) Breda de Haan is cited as the author. Revision of the taxonomy of the genus *Helminthosporium* was necessary after it was realized that the type species *Helminthosporium Link ex Fries* forms its conidia apically and laterally on the sporophores, whereas the conidia of the graminicolous species are formed in sympodia. Subramanian & Jain placed the species with sympodia in the genus *Drechslera*.

The species found on rice - *Drechslera oryzae* - is distinguished from other species by the following characteristics: the conidia are mostly longer than 40 µm, rarely branched, and most are curved. The hilum is very small, somewhat protruding, and papillate. A full description is given by Ellis & Holliday (1971).

The perfect stage of *Drechslera oryzae* has been described by Ito & Kuribayashi (1927) as *Ophiobolus miyabeanus*. Drechsler (1934) placed the species of the genus *Ophiobolus* with corkscrew-like ascospores in the genus *Cochliobolus*. This was validated by Dastur (Sprague, 1950; Ou, 1972). Nothing is known about the role of the perfect stage in the life cycle of the pathogen. There is no indication that multiplication in the field occurs by spores other than conidia.

The Wageningen Polder has been combed for the perithecia of *Cochliobolus miyabeanus*. However, they have never been found in the field on any plant or remains of a plant. Perithecium-like globules were found in cultures in conical

flasks on different culture media and especially on cargo-rice cultures. They were formed mainly against the glass. Structural changes within the globules were observed a few weeks after their formation, but asci were never found. Isolates of *Drechslera* from rice and *Ischaemum rugosum* were placed on water-agar on either side of a piece of rice leaf 3 cm long. The leaf surface was quickly covered with mycelium, and about midway between the two isolates about 10 black globules were formed. A month after their formation, these structures still did not contain asci, and the experiment was discontinued.

The formal description of *D. oryzae* gives a wide range for size, shape, and colour of conidia and conidiophores. All isolates fitted this description but there was considerable variation. It is difficult to discriminate between isolates and groups of isolates within the system of phylogenetic taxonomy. A discriminative method is given by numerical taxonomy.

6.2.2 *An adventure in numerical taxonomy*

The purpose of numerical taxonomy is to group organisms by judgement of affinity based on multiple and unweighted characteristics. The organisms to be grouped are called 'operational taxonomic units' (OTU) (Sokal & Sneath, 1963). In the experiment described below *Drechslera* isolates originating from single spots were regarded as OTU.

Morphologic and physiologic characteristics of Drechslera isolates The experiment was with 22 *Drechslera* isolates from 8 different rice cultivars and 2 grassy weeds (Table 17). The rice cultivars were grown together in the same field.

Table 17. Host origin of *Drechslera* isolates used for numerical analysis.

Isolate No	Origin
1, 2	SML Magali
3	Taichung native 1
4	SML Apikalo
5	SML Apura
6, 7, 8	SML Alupi
9, 10, 11	BG 79 (plot 1)
12, 13	BG 79 (plot 2)
14	SML Galibi
15, 16, 17	Peta (plot 1)
18, 19, 20	Peta (plot 2)
21	<i>Echinochloa colonum</i>
22	<i>Cynodon dactylon</i>

Echinochloa colonum was taken from a high spot in that field and *Cynodon dactylon* was found on the adjacent field dike. The isolates were cultures on three media: oatmeal agar 2 %; potato-dextrose agar containing 20 % potato decoction, 2 % dextrose, and 1.2 % agar No 3 from Oxoid; malt agar Oxoid CM 60. The cultures were incubated under continuous fluorescent light (Section 6.1.4). The ambient temperature varied diurnally between 25 and 35 °C. The observations made after 2 weeks of incubation are given in Appendix B.

The number of growth rings ranged 0-4 being 3 in most cultures. In some flasks, white saltation patches were seen, the most on oatmeal agar, the fewest on malt agar. Large differences between substrates were observed. Spores were counted in four replicates with a haemocytometer. The spores had 6-10 cells. They were 30-100 µm long. The widest cell of a spore normally measured about 16 µm. To indicate the shape of the spores the ratio between the number of cells above and below the widest cell was noted. The upper part of the spores was about twice as long as the lower part characterized by the hilum. On oatmeal agar the spores were generally longer than on the other media.

Dendrogram analysis In Appendix B, columns represent isolates and rows represent properties. The number of isolates tested was too small to assume a normal frequency distribution. Therefore the observations were scaled, so that the average equalled 0 and the standard deviation equalled 1, by means of the equation

$$x'_{ij} = (x_{ij} - \bar{x}_i) / s_i$$

where

- x'_{ij} = the scaled observation for property i and isolate j
- x_{ij} = the original observation
- \bar{x}_i = the arithmetic mean of observations for property i over all isolates
- s_i = the standard deviation of the observations for property i over all isolates.

The relation between the *Drechslera* isolates is expressed as the product-moment correlation coefficient, using the scaled data. The correlation coefficients between all pairs of isolates are given in Appendix C. These coefficients were used to group the isolates according to their degree of association. As a first step of the procedure, those pairs of isolates with the highest correlations were taken as group nuclei. One such nucleus was formed by the pair of isolates 11 and 13. The correlation coefficient between 11 and 13 was 0.7, which is the

highest of the coefficients for 11 and any other isolate, and also for 13 and any other isolate. The nuclei for other groups of isolates were the pairs 15 and 16, 18 and 20, 8 and 21, and 6 and 22. The correlation coefficients between these nuclei and the other isolates were calculated by Spearman's equation for sums of variables. This procedure yielded a new matrix of correlation coefficients which formed a basis for further grouping of the isolates. The process was iterated until all isolates were brought together. The result of this exercise is presented in a dendrogram (Fig. 14).

The Drechslera isolates used in the experiment fall into two main groups which can be divided into subgroups as follows:

Group 1: Subgroup 1: isolates 9, 10, 11, 13, all from cultivar BG 79

Subgroup 2: isolates 15, 16, 17, 18, 20, and to some degree 4, all from Peta except 4 from SML Apikalo

Subgroup 3: isolates 3, 5, 12, 14, 19, from Taichung native 1, SML Apura, BG 79, SML Gabili, and Peta respectively

Group 2: isolates 1, 2, 6, 7, 8, 21, 22 from SML Magali, SML Alupi, Echinochloa colonum, and Cynodon dactylon.

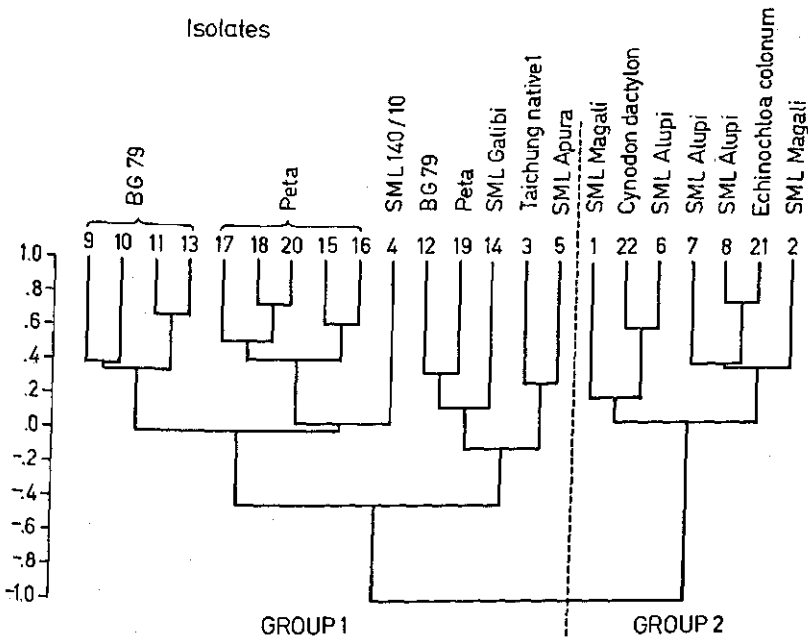

Figure 14. Relations between Drechslera isolates according to a technique of numerical analysis. Isolates are grouped in a dendrogram. Abscissa - isolates indicated by number and source. Ordinate - correlation coefficients (see text).

Discussion The average values of the measured properties of the groups of isolates found in the dendrogram are listed in Appendix D. Groups 1 and 2 differ in their number of growth rings and the number of spores formed. The subgroups of group 1 differ mainly in the number of spores on the nutrient media: the isolates from Subgroup 1 form few spores on all three media; Subgroup 2 forms many spores on oatmeal agar and fewer on the other agars; Subgroup 3 forms few spores on malt agar. The isolates from the rice cultivars Peta and BG 79 are clearly discernible, and the other isolates also fall into groups according to their host plants. Isolates which are phylogenetically identical (all *D. oryzae* with the possible exception of the isolate from *Cynodon dactylon*) have morphologic characteristics determined by the rice cultivar on which they grow; these characteristics remain constant for at least two successive generations on agar. Another mathematical technique, that of factor analysis, applied to the same data gave similar results.

6.3 SPORE GERMINATION

6.3.1 Germination in guttate

Germination of spores of many fungi can be stimulated by adding amino acids, sugars, minerals, and enzymes to a spore suspension. This led to investigations on the influence of leaf exudates on spore germination. At night, substances are pressed through hydathodes or stomata (ooze) or pass by diffusion (exudate) to the leaf surface in areas with cool air, high humidity and warm wet soils. This guttate (ooze + exudate) consists of water with dissolved salts, sugars, enzymes and other organic substances normally found in plant tissue (Ivanoff, 1963; Stocking, 1956). Guttate of rice contains a number of amino acids, in amounts related to the dose of nitrogen given to the crop (Suryanarayanan, 1956; Subba-Rao & Suryanarayanan, 1957; Sadasivan, 1959). The trial described below was designed to investigate the influence of guttate on the germination of *D. oryzae* spores.

In concreté reservoirs (1 x 1 x 0.5 m) filled with Wageningen clay, 12 rice cultivars were grown. A plastic roof at a height of 2.5 m above the reservoirs prevented dew forming thus avoiding dilution of the guttate. The water level in the reservoirs was maintained at 10 cm above soil surface by irrigation. Droplets of guttate were sucked from the leaves with a micropipette in the early morning hours, and collected in weighing bottles. Droplets, 0.02 ml each, were transferred to a transparent colourless Perspex plate. About 100 spores from a dry culture

were suspended in the droplets, the plate was turned upside down and placed over a Petri dish containing some water to prevent quick evaporation of the droplets. This 'hanging droplet' method was used to try to avoid thigmotropic reaction and formation of appressoria. The guttate of each of the 12 cultivars was tested twice at an interval of 1 week. Spore germination was assessed in three droplets of 0.02 ml guttate and in four droplets of 0.02 ml distilled water. The spores used in this test were isolated from cv. Peta.

The results of the trials indicate that spores of *D. oryzae* germinated faster in guttate than in distilled water. There were no clear differences between cultivars.

6.3.2 Effect of substrate

The droplets were hung on one single Perspex plate. During tests, the time between hanging of the droplets and 50 % germination increased gradually. The cause of this phenomenon was enigmatic, so the influence of several materials on spore germination was studied. A series of experiments revealed that the rate of germination depended upon the substrate used and upon the way it was cleaned (Table 18). The period needed for the germination of 50 % of the spores increased with cleanliness and hardness of the substrate. Soft, unclean material apparently contains substances that stimulate germination. It was difficult to reproduce experimental results. The best reduplication was achieved in tests with slow germination on cleaned porcelain plate. However it was only with special lighting that germination on this opaque material could be observed. Routine tests on the rate of germination were, therefore, done on a Perspex

Table 18. Period from inoculation till time at which 50 % of the spores of *D. oryzae* were germinated in distilled water.

Substrate	Period (min)
New poly(vinylchloride) (PVC) weighing bottle	67
PVC weighing bottle rinsed with distilled water	110
PVC weighing bottle rinsed with ethanol 50 %	120
Perspex plate new	65
Perspex plate, boiled out	120
Perspex plate, boiled out, and cleansed with ethanol 96 %	200
Porcelain plate cleansed with concentrated sulphuric acid	280
Quartz	110
'Plastic' plate, used	60

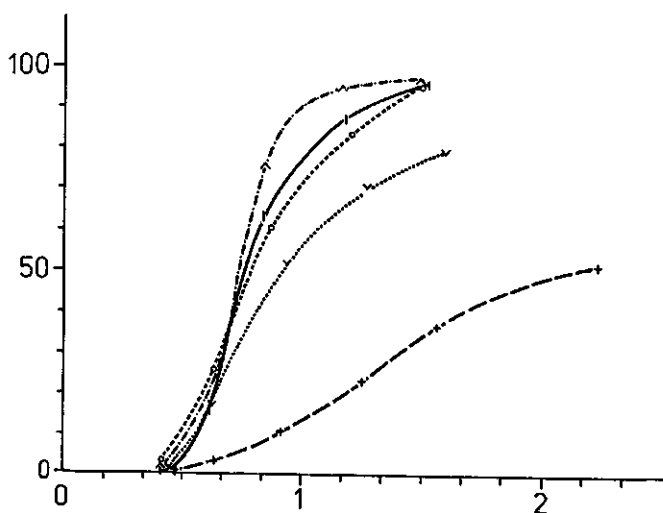

Figure 15. Germination of conidia of *D. oryzae* in guttate from four rice cultivars and in distilled water. ^Texas Patna, |Temerin, oToentoeng, vPeta, + distilled water.
 Abscissa - time in hours.
 Ordinate - germination in %.

plate that was cleaned by a regular procedure and stored under constant conditions. In Figure 15, the curves for the rate of germination are shown for four cultivars. Guttate stimulates germination of conidia of *D. oryzae*. Whether the differences found are statistically significant can be tested with the t-test for paired comparisons. The mean of sample differences between pairs of readings in two germination liquids is tested over the standard error of the mean difference (Sokal & Rohlf, 1969). In this experiment there is a highly significant difference between the rate of germination in distilled water and in guttates of the various cultivars. Differences between cv. Peta and the other cultivars are also significant; the other cultivars do not differ significantly among each other in their stimulation of germination of *D. oryzae* spores. The epidemiological meaning of these observations is a matter of conjecture only.

6.4 INOCULATION TECHNIQUES

6.4.1 Seedling inoculation

Methods Seed of 12 rice cultivars was germinated in Petri dishes and planted in pots, 9 cm high with upper diameter 9 cm. Four seeds per pot were planted. The pots were placed in trays filled to a depth of 2.5 cm with tap water. Trays with

a capacity of 24 pots provided a working unit of 96 plants. The plants were inoculated at Stage 1 with 2-4 leaves, about 2 weeks after sowing. The spore suspension used for inoculation was prepared by shaking some profusely sporulating grains from a cargo-culture in distilled water. The concentration of spores in the suspension was standardized at 20×10^6 litre⁻¹. Per litre spore suspension 200 ml of a solution containing 0.025 % gelatin and 0.05 % sodium oleate were added; 30 ml of this suspension was sprayed over each working unit. The trays with inoculated plants were placed in a cage of wet cheese-cloth wrapped in plastic foil to maintain the relative humidity at the point of saturation for at least 48 h. The plants were kept in the dark for 48 h in an air-conditioned room with temperatures of 20-21 °C. The plants were then taken out of the cages, and placed in the laboratory under normal room conditions. Assessments were made 24 h later.

Results The cultivars Blue Bonnet 50 and CI 5309 formed only 2 leaves before inoculation, the other varieties formed three leaves. For some cultivars the number of lesions was highest on the youngest fully unfolded leaf, with some cultivars the largest number of spots was on the oldest leaf; a third group had the largest number on Leaf 2 (Table 19). A conclusion about susceptibility is not possible without a statistical test. An analysis of variance for the square roots of the lesion counts, with leaves regarded as 'blocks', reveals that the added variance component between cultivars is just significant at 5 % probability.

Table 19. Number of *D. oryzae* lesions formed on leaves 5 days after inoculation of rice seedlings. Leaves are numbered from the apex downwards; Leaf 1 being the youngest completely unrolled leaf. Growing conditions were the same in all tests. Each value is a mean for one working unit (96 plants).

Cultivar	Leaf No			
	0	1	2	3
Ishikare shiroke	0	21	63	128
SML Apura	0	50	110	73
SML Apikalo	0	68	173	44
SML 13/227	0	89	109	216
Bluebonnet 50	0	115	100	-
CI 5309	0	119	129	-
SML Magali	0	120	53	10
Taichung native 1	0	130	367	296
CI 9453 x CI 9187	0	169	437	591
SML Alupi	0	262	120	72
BG 79	0	336	410	100
Bengawan	0	493	265	40

However the variance within cultivars was so large relative to the variance between cultivars that seedling inoculation as a technique to assess cultivar susceptibility was rejected.

The rejection was corroborated by a series of six trials (Table 20). There was no consistency in cultivar reaction from one trial to another. The data suggest that the number of lesions on inoculated seedlings was not indicative of susceptibility of rice cultivars to brown spot, a problem mentioned elsewhere (Vorraurai & Giatgong, 1971; Solangi et al., 1970).

Table 20. Reaction on the upper three unrolled leaves 5 days after artificial inoculation of rice seedlings with conidia of *D. oryzae*. Cultivars are listed in order of increasing susceptible reactions.

Cultivars	Test No					
	1	2	3	4	5	6
Arkrosse x Bluebonnet	R	R	R	R	R	R
SML Apura	R	R	R	M	R	R
Sunbonnet	M	M	R	R	R	R
SML Tapuripa	R	R	M	R	R	-
Te-tep	R	R	M	M	R	-
D 52/27	R	M	M	R	R	M
SML 508	M	M	R	M	R	M
221/BCIV/I/178/11	R	M	S	R	R	M
SML 757	M	R	R	S	R	M
SML Temerin	M	R	S	R	R	M
SML 13/227	M	M	R	R	S	M
BG 79	S	R	M	M	R	-
Peta	R	R	S	S	M	-
221/BCIV/I/178/13	M	M	S	R	S	R
Skrivimankoti	M	M	S	M	R	M
221/BCIV/I/45/8	M	S	S	M	R	M
Nang Quot	S	S	M	R	M	M
SML 40c/27b	R	M	S	S	M	-
221/BCIV/I/178/6	M	R	S	S	M	-
221/BCIV/I/178/9	S	M	M	S	S	R
Bengawan	M	M	M	S	M	M
Bengawan	M	M	M	M	M	M
221/BCIV/I/178/3	S	M	S	S	S	S

R = Resistant: < 100 lesions on the upper three unrolled leaves.

M = Medium susceptible: 100-150 lesions on the upper three unrolled leaves.

S = susceptible: > 150 lesions on the upper three unrolled leaves.

6.4.2 Sheath inoculation

It is not easy to peel off the epidermis of rice leaves to study the infection process at cell level. The leaf surface is too irregular. Treatment of whole leaves with chloral hydrate does not clarify leaves enough for light microscopy. To overcome these difficulties, Sakamoto (1951) developed the leaf sheath inoculation technique, primarily to study infection by *Pyricularia oryzae*. The technique was based on the ease with which the epidermis of the inner side of rice leaf-sheaths could be peeled off. This epidermis is practically hyaline. Spore germination and penetration can, therefore, be followed under the microscope.

Procedure The technique of inoculation was slightly adapted to study the infection process by *D. oryzae*. Leaf sheaths were cut into segments of about 6 cm long. Young folded leaves were removed from the sheath segments. To avoid in-rolling of the sheath, 'stoppers' consisting of half a centimetre of young folded leaves were left behind at both ends of the segment (Fig. 16). With a scalpel a window (length 4 cm, width 0.5-1 cm) was cut in the sheath segment opposite the mid-rib. Spores from a cargo culture were picked up with a fine brush and spread evenly through the window onto the inner side of the sheath segment. At least 40 spores were used per segment and the spores were spaced carefully. The inoculated segments were transferred to Petri dishes with wet cotton wool. The dishes were covered, packed in plastic bags to avoid desiccation, and stored at a temperature of 20-21 °C. After an incubation for 24 or 40 h, the inner epidermis was carefully peeled off and put on an object-glass, side with spores up, in a hypertonic saccharose solution (0.6-0.8 mol/litre) to plasmolyse the cells. At least 10 infection spots were observed per epidermis fragment.

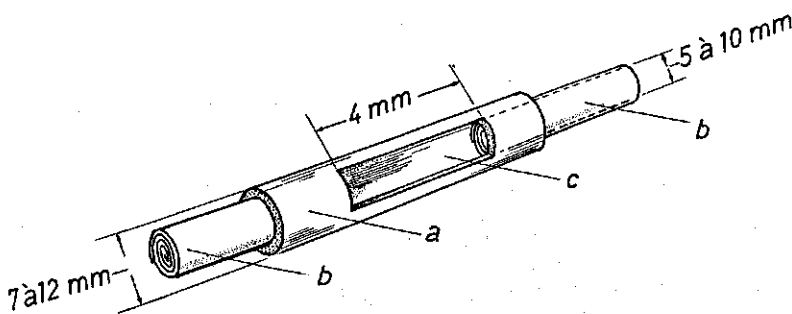

Figure 16. The technique of sheath inoculation of Sakamoto (1951). Segment of leaf sheath (a) with 'stoppers' of young folded leaves (b). Spores were spread with a brush through the window (c) on the innerside of the sheath.

Observations on the infection process At the end of a germ tube, a round to oval appressorium was formed, 1.5-2 times as wide as a hypha. In the centre of this appressorium a very thin hypha was formed that penetrated mostly between two cells. The pectinous middle lamella between two cells was dissolved. The cell walls separated. Between the walls, a hypha with two or three septa was formed. This hypha sometimes penetrated the cell wall into the protoplasm of epidermal cells and grew until the whole cell was filled. At the same time, one or more hyphal branches extended to neighbouring cells. Often a hypha continued out of the cell and grew over its surface before penetrating another cell. Intracellular hyphae grew without branching straight through a number of cells. A few examples of the infection process are drawn in Figure 17. Infected cells

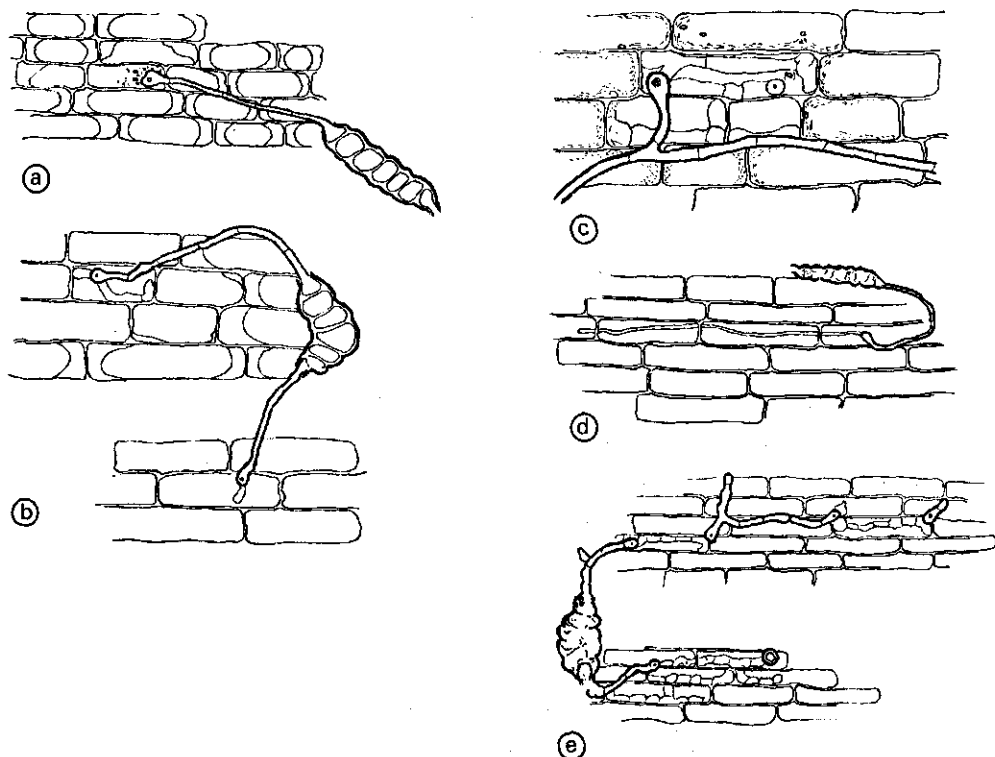

Figure 17. Infection by *D. oryzae* of the inner epidermis of artificially inoculated rice leaf - sheaths. (Drawings by M.H.E. Dassen, 1968.)
a: penetration of the cell wall; some granulation of the cell contents.
b: first hyphae formed inside a cell.
c: two cells nearly filled with mycelium; granulation of the contents of cells surrounding the invaded cells.
d: runner hyphae through a row of cells.
e: mycelium reappears at the cell surface and penetrates another cell at some distance.

and often adjacent cells could not be plasmolysed. Apparently cells were killed before infection. Infected cells and cells around the infection court reacted by browning and granulation of the protoplasm. Crystal-like bodies were also formed within the cells.

Stages of invasion by the fungus and reactions of the host On the basis of data from literature and experience gained in introductory tests stages of invasion by the fungus and reactions of the host like discoloration and granulation of the cell contents in the area around the infection court were defined and numbered (Table 21). Stage 0 indicates no action and no effect. Stages 1-10 of the F-scale

Table 21. Codes for the invasion by *D. oryzae* of rice leaf sheaths and the reaction of the host cells.

F	Fungal invasion	H	Host reaction
0	no appressorium formed	0	no reaction
1	penetrating hyphae formed; penetration between two cell walls; quarter of one cell filled with mycelium	1	dark cell wall and/or accelerated streaming of protoplasm and/or slight granulation of the protoplasm
2	half of one cell filled with mycelium; penetration of a second cell possible	2	contents of one or two cells faint yellow, around the point of penetration some cells with large granules
3	one cell filled with mycelium or two cells each half-filled	3	several cells around the point of infection with a yellow shade, and granulated protoplasm; 'chrysanthemum' shaped bodies; in some cells large crystals
4	one cell filled with mycelium and another cell penetrated	4	light yellow colouration of cell contents with or without granulation of the protoplasm
5	two cells filled with mycelium or three cells partly filled	5	yellow colouration of cell contents without granulation or light yellow densely granulated contents
6	three cells filled with mycelium or three cells partly filled and penetration of a fourth cell; or mycelium lying over the surface of three cells	6	yellow densely granulated cell contents
7	four to five cells penetrated or mycelium lying over the surface of four cells	7	dark yellow cell contents
8	six cells penetrated or covered with mycelium	8	dark yellow cell contents with granulation
9	seven or eight cells penetrated or covered with mycelium	9	cell contents brown
10	more than eight cells penetrated or covered with mycelium	10	cell contents brown and granulated

describe successive stages of invasion by the fungus at a site. The H-scale describes successive grades of reaction by the host cells at that site. The inverse of the H-value H^{-1} is, therefore, a qualification of tolerance (Fed. Br. Pl. Pathologists, 1973). Stages F 1 to F 5 refer to infection and colonization of one to two cells; stages F 6 to F 10 are a measure of development of the mycelium in a group of cells. Stages H 1 to H 10 are based mainly on increasing colour intensity of the cell contents; granulation and coagulation are corollaries. Crystal-like bodies and 'chrysanthemum'-shaped coagulations are mainly found in cells with only slight discoloration.

6.4.3 Sheath inoculation of 12 rice cultivars

The following rice cultivars were tested at different growth stages:

Tetep
221/BCIV/I/178/11
221/BCIV/I/178/13
221/BCIV/I/178/ 3
221/BCIV/I/ 45/ 8
SML Apura
SML Temerin
BG - 79
Bengawan
SML 140/5
Peta
Skrivimankoti.

Figure 18 summarizes the assessments 24 and 40 h after inoculation. As there were no differences between the cultivars, all available observations were pooled. The variation between F-values was large in Growth Stages 5 and 6 of the rice and small from Growth Stage 7 on. F-values were lowest in Growth Stages 7 to 9 and then increased with plant age. The variation between the H-values of different cultivars was large in Growth Stages 5 and 6 and small from Stages 9 or 10 on. On average, the H-value decreased with plant age. Both F and H indicate that the rice plant became increasingly susceptible from Growth Stage 7 on. This phenomenon was also observed during an epidemic (Chapt. 5 and 7).

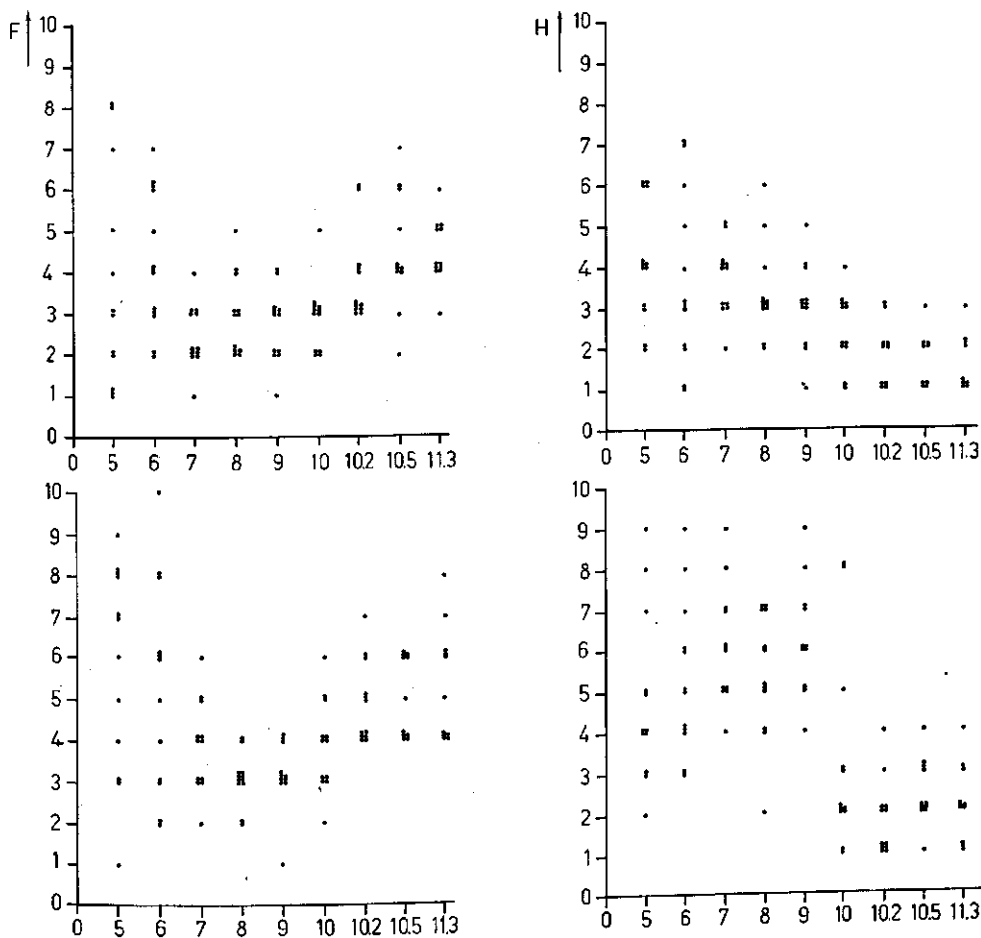

Figure 18. Invasion of rice leaf - sheaths by *D. oryzae* (left) and reaction of the host (right) in relation to growth stages of rice in 12 rice cultivars 24 h (upper graphs) and 40 h (lower graphs) after inoculation. Abscissa - growth stages according to Feekes (Table 14). Ordinates - F-code for fungal invasion H-code for host reaction (Table 21).

6.5 DISCUSSION AND CONCLUSIONS

D. oryzae can invade the rice plant at all growth stages. Evidently it is a pathogen and not just a weak parasite. The most conspicuous symptoms are leaf spots. The spots on young actively growing leaves remain small, spore formation is limited. Lesions are large and spores are abundant on ageing leaves. This indicates that *D. oryzae* is a pathogen with a low virulence, in other words, with a low capacity to cause disease. According to Padmanabhan & Ganguly (1954)

the susceptibility of rice to *D. oryzae* increases with the age of the plant. This is corroborated here by the relation between F and H and the growth stage of the plant.

An increasing susceptibility of all rice varieties tested during the reproductive growth phase means that the disease expression due to *D. oryzae* is enhanced by weakness of the host.

The killing of cells surrounding the brown leaf spots and the formation of an abundance of spores in that area is evidence that *D. oryzae* has the character of a perthophyte. Guttate stimulates the germination of conidia of *D. oryzae*. There is a marked influence of the host on the morphology of the fungus spores. Physiologic specialization could not be demonstrated, nor could differences between cultivars in resistance to *D. oryzae* be defined.

7 Epidemiology

7.1 HISTORICAL REVIEW

Table 22 reviews the occurrence of rice diseases in the Wageningen Polder. In 1954, the first year of operation, a severe epidemic of narrow brown leaf-spot and rice blast occurred on the cultivars Rexoro and Bluebonnet 50. These United States cultivars were planted because they were better suited to mechanized farming than the available Surinam cultivars. However the severity of the diseases encouraged rapid replacement by the Surinam cultivar Dima, selected a few years earlier at the Agricultural Experiment Station in Paramaribo. Dima surpassed Rexoro and Bluebonnet 50 in yield and in many other ways (de Wit, 1960). Its susceptibility to *D. oryzae* was known but was not thought to be of practical importance because Skrivimankoti, the major Surinam cultivar since 1900, was also susceptible to *D. oryzae* and never really suffered from the disease. Dima remained the principal cultivar grown in the Wageningen Polder until 1960.

Against expectations severe epidemics of brown-spot occurred in the spring-sown crops of 1956, 1957 and 1959, and in the autumn-sown crops of 1956 and 1958. New cultivars selected at the station of the SML in the Prins Bernhard Polder were planted on limited areas in the Wageningen Polder between 1954 and 1960. In 1958, the spring-sown crop of SML 80/5 was severely infected with *Cercospora oryzae*. A series of new cultivars was introduced in 1960 (ten Have, 1967). A brown-spot epidemic developed on the older cultivars in the spring-sown and autumn-sown crops of 1960. The new cultivars were heavily infected in 1963, 1966 and 1967 (spring-sown crops) and in the autumn-sown crop of 1967. In 12 out of the 32 cropping seasons listed in Table 22 an epidemic of brown spot occurred; in two seasons, the crop suffered from narrow brown leaf-spot and rice blast. In the other cropping seasons infection was negligible.

7.2 SOURCES OF INOCULUM

D. oryzae was common on grasses growing on the levées between the rice fields and on higher places in the fields. Together with the grasses, self-sown rice plants

Table 22. The incidence of rice diseases in the Wageningen Polder based on reports of SML which do not always specify the pathogen. The spring-sown crop is sown between the middle of March and the end of May and harvested between the beginning of September and the end of November of the same year. The autumn-sown crop is sown between the middle of October and the end of November of one year and harvested between the end of February and the end of April of the following year.

	Spring-sown crop	Autumn-sown crop
1954	<i>Cercospora oryzae</i> and <i>Pyricularia oryzae</i> . Susceptible cultivars Rexoro and Bluebonnet 50. Severe epidemic of both diseases.	Diseases negligible. Dima introduced.
1955	Diseases negligible. 1800 ha (95 % of area) sown with Dima.	Organic matter incorporated (Section 6.4); diseases negligible.
1956	3500 ha Dima severely infected by <i>Drechslera oryzae</i> from booting on; rank growth in vegetative stage; rapid deterioration of crop resembling withering, accompanied by fungal infection in generative stage.	Organic matter burnt (Section 6.4); heavy infection in the south of the polder (rank growth), less severe in the north (less lush growth); Dima severely infected by <i>D. oryzae</i> . Rapid deterioration of the rice in the generative stage.
1957	Heavy infection of lush crops (mainly in the south of the polder); <i>D. oryzae</i> on Dima, <i>P. oryzae</i> on Nickerie, <i>C. oryzae</i> on SML 80/5.	Less lush growth; less infection.
1958	Severe epidemics of <i>C. oryzae</i> and <i>P. oryzae</i> , especially in the north of the polder; high yields of Dima.	Development of brown spot late in the growing season; some yield losses.
1959	Deterioration of the crop 60-110 days after sowing, accompanied by <i>D. oryzae</i> infection; heavier infection on lush crops.	Disease negligible.
1960	Severe epidemic of brown spot disease. Infection in the south of the polder in vegetative stage, in the north of the polder in the generative stage.	Brown spot in January and February 1961, during the generative stage.
1961	Disease negligible; introduction of dry fallow and temporary drainage of the crop once or twice during the growing season (Section 6.4).	Some <i>P. oryzae</i> on young crop of Magali; recovery later in the season; some <i>D. oryzae</i> on SML Tapuripa later in the season.
1962	Disease negligible; some leaf spots on SML Tapuripa and SML Apikalo.	Disease negligible; some leaf spots on SML Tapuripa and SML Apikalo.

Table 22. continued

1963	Severe leaf infection by <i>D. oryzae</i> a month before harvest.	Disease negligible; wet weather during tillage; dry during entire growth period (Section 6.4).
1964	No disease; dry weather during tillage; wet during growth and harvest.	No disease; dry weather during tillage and harvest.
1965	No disease; dry weather during tillage and harvest.	Disease negligible; dry weather during tillage and harvest.
1966	Severe epidemic of brown spot from flowering onwards; premature ripening of heavily infected crop.	Disease negligible except on Temerin (empty grains).
1967	Heavy brown spot during later ripening; no influence on yield.	Early infection by <i>D. oryzae</i> ; yield depression; on fields that received 3rd top-dressing with urea, less disease and higher yields than on fields with two top-dressings.
1968	Brown spot disease mainly in the south of the polder. Yield losses moderated by a third nitrogen top-dressing.	Brown spot negligible.
1969	Disease negligible.	Disease negligible.

and ratoon tillers on fallow fields formed an evenly distributed source of inoculum throughout the year. Infections up to 75 % were normal on *Echinochloa colonum*, *Leptochloa scabra*, and *Ischaemum rugosum* at all growth stages. These grasses formed the main source of inoculum for the newly planted rice crops. The infection gradually spread over the fields from border to centre. Foci were rarely found, and usually originated from grasses growing on high spots in the fields. There were no differences between the levels of infection of crops adjoining to fallows as compared to crops adjoining sown fields. Ratoon tillers on fallow fields sometimes remained healthy whereas adjoining crops were infected.

7.3 PROGRESS OF BROWN SPOT DISEASE AND HOST-DEPENDENT FACTORS

The severity of infection was defined as the percentage leaf surface covered by lesions. Dead leaves were ignored. Severity was assessed by one of the following classes: 0.01, 0.1, 1, 5, 10, 15, 25, 50, 75, and 100. Time was recorded as the number of days from sowing. In addition, the growth stage was noted.

In the spring and autumn of 1966 and the spring of 1967, the international

collection of cultivars mentioned under Section 4.1, supplemented with SML cultivars and selections, was sown in plots of 1.5 x 3 m on a well-tilled field, which was treated in the same way as commercial fields. The diversity of the collection is reflected in the wide range of growing periods. The collections of 1966 and 1966/67 (Table 23) were larger and more varied in growing period than the series of 1967 (Table 24) because some cultivars and lines failed to produce viable seed and hence could not be sown in the third season.

The collection was used to study the relation between disease incidence and growth stage regardless of the developmental rhythm of the cultivars, and of the date of observation. Figure 19 depicts the severity at different growth stages, averaged over all lines. In 1966, the general level of infection was low. The maximum severity, attained on a few cultivars only, was 25 %. In the autumn-sown

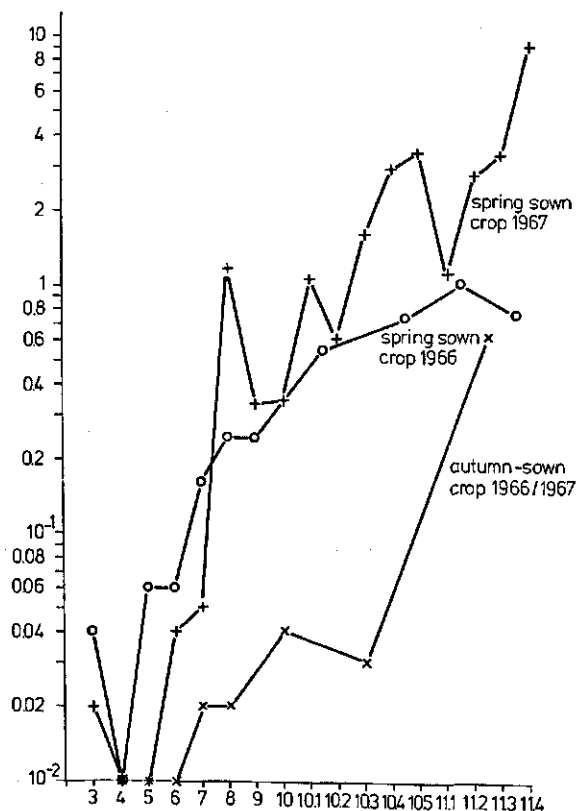

Figure 19. Severity of infection by *D. oryzae* at different growth stages, averages over selection lines and cultivars (Section 7.3).
 Abscissa - growth stages according to Feekes (Table 14).
 Ordinate - severity in %.

crop of 1966/67 the maximum reached was 10 %. The effect of photosensitivity was marked: many cultivars sown in the autumn of 1966 ripened 10 to 30 days earlier than the same cultivars in the previous season. In the spring-sown crop of 1967, infection reached an appreciable severity in the ripening stages. In all three seasons, severity increased with plant age of the crop.

Cultivars with a short growing period had little disease. In the spring-sown crop, some cultivars took 140 days from growth stage 0 to 10.1. These cultivars also showed little disease. Generally, a high terminal severity was most frequent among cultivars that started flowering about 100 days after sowing (Fig. 20 and 21). It seems that susceptibility of rice to *D. oryzae* is physiologically linked with the duration of the period from Growth Stages 0 to 10.1.

The spring-sown crop of 1967 was particularly interesting. There were two epidemics on the same plots. One was caused by *Pyricularia oryzae* and as soon as that died down, *D. oryzae* took over (Fig. 22). Neck blast caused by *P. oryzae* was absent.

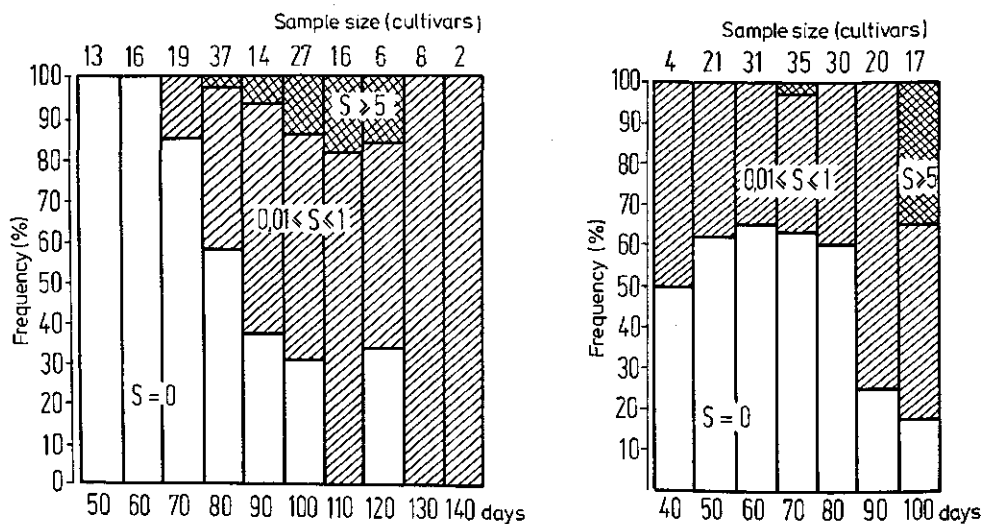

Figure 20. Relation between duration of growth of the rice plant and severity of infection by *D. oryzae*. 1966 spring sown crop.

Figure 21. Relation between duration of growth of the rice plant and severity of infection by *D. oryzae*. 1966 autumn sown crop.

Lower abscissa - Length of the period from growth stage 0 to growth stage 10.1.
 Upper abscissa - Sample size (cultivars).
 Ordinate - Relative frequency (%) of the occurrence of the severity of infection specified by the entries in the picture.
 Entries - Severity of infection (%).

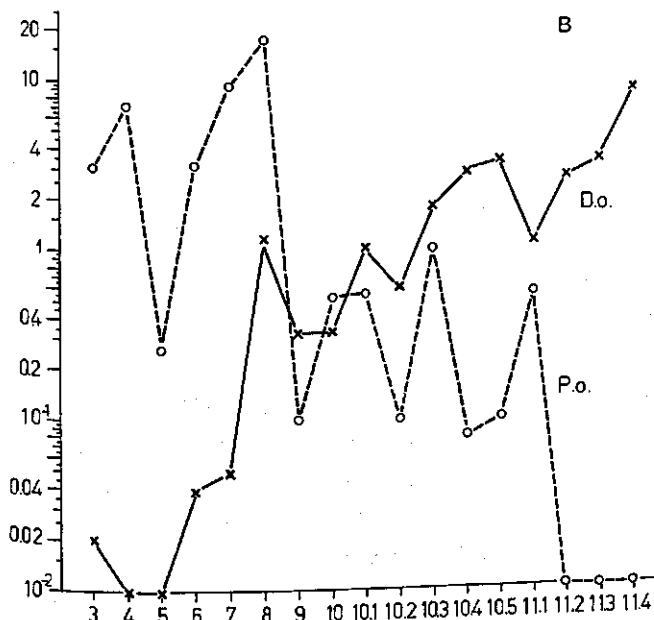
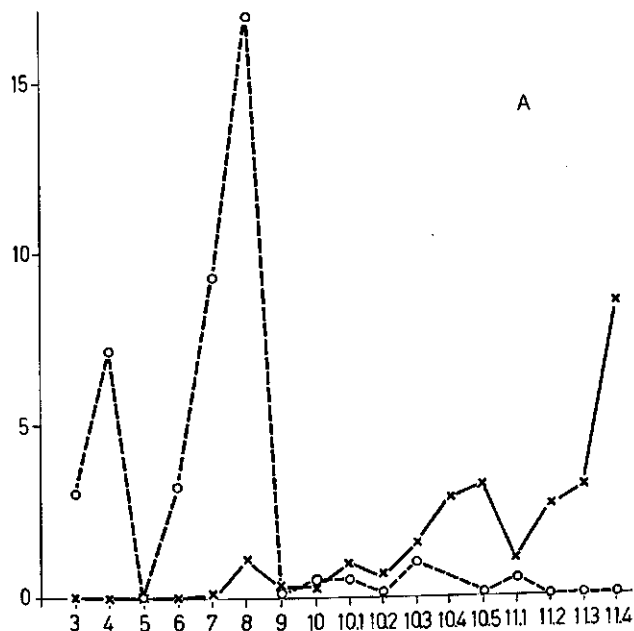

Figure 22. Epidemics of *Pyricularia oryzae* and *Drechslera oryzae* occurring in the same spring sown crop of 1967.

Abscissa - growth stages according to Feekes.

Ordinates - Figure 22a - Severity of infection plotted on a linear scale;

Figure 22b - Severity of infection plotted on a logarithmic scale.

P.o. = *Pyricularia oryzae*

D.o. = *Drechslera oryzae*

7.4 ENVIRONMENTAL CONDITIONS

The first crop losses in the history of the Wageningen Polder were caused by *Pyricularia* and *Cercospora* and not by *Drechslera*. Brown spot was mentioned for the first time in 1956 (Table 22) two years after the introduction of the susceptible cultivar Dima, and one season after incorporation of the top layer of organic matter into the underlying clay. This incorporation became necessary because heavy rains during reclamation in 1955 and 1956 prevented its elimination by burning. As a consequence the crop showed lush growth during the vegetative phase (de Wit, 1960), and a marked deterioration during the generative phase accompanied by a severe infection by *D. oryzae*. The lush growth indicated a release of a large amount of ammonia and possibly other nutrients that are directly available to the rice plant. In those years, only one nitrogen dressing was given 60-70 days after sowing, which is in the middle of the vegetative phase.

De Wit (1960) stated that the 1955-crop received too much nitrogen. The Surinam cultivars tended to consume all available nitrogen during vegetative growth and to leave too little nitrogen for panicles and grain. Scheltema (1974) stated that the nitrogen available at the beginning of the season lasted only until tillering for most cultivars, but until panicle initiation for Apura. In 1955 and 1956 there was apparently an imbalance between vegetative growth and the generative growth. This imbalance induced deterioration of the crop in the second half of the growing season and increased incidence of brown spot (Baba, 1958; Takahashi, 1967).

A situation similar to that in 1956 occurred in the spring-sown crop of 1959. In the southern part of the polder, that had been reclaimed earliest, the organic matter incorporated in the soil no longer influenced growth. In that part of the polder, Dima grew normally throughout the season and not lush. It was not infected by *D. oryzae*. In other parts of the polder, lush crops on recently reclaimed fields deteriorated 60-110 days after sowing and showed marked incidence of *D. oryzae*.

From 1960 on, the rice crops showed deficiency of nitrogen, and possibly also of other nutrients, rather than excess as in the first years. The need for fertilizer increased. Between 1960 and 1967, nitrogen was applied in two top-dressings, the first at Growth Stage 3 to 4 (vegetative), the second at Growth Stages 5 to 6 (early generative). Apart from the second top-dressing there were other changes in the method of rice farming that affected the incidence of brown-spot. Dry fallowing was introduced. Weather permitting, a field was left dry once in three cropping seasons. The crop was drained once or twice during the season,

thereby counteracting harmful effects of strong reduction in the soil (Baba, 1958; Ponnamperna, 1965). Finally the herbicide propanil was introduced for grass control (ten Have, 1967).

These changes in farming practices reduced infection of the newly selected cultivars below detectible level. An epidemic did not occur till 1963. During the first months of that year it rained excessively. Dry tillage was not possible on about 20 % of the area to be sown; another 20 % could only be partially tilled under dry conditions. On fields with dry tillage, subsequent infection by *D. oryzae* was less severe than on fields with dry/wet or wet tillage. There was another epidemic in 1966, again after wet tillage because of heavy rainfall.

In 1967, infection occurred on the spring-sown and the autumn-sown crops. The spring-sown crop was infected late and weather and soil had no obvious effect. The autumn-sown crop was planted under wet conditions. Nevertheless many fields were dry-tilled. The quality of this tillage was, however, so bad that a seedbed was difficult to prepare. In the meantime, it was found that a third top-dressing could prevent a further increase in disease severity and reduce chlorosis. The third nitrogen top-dressing was introduced in the autumn-sown crop of 1967. A nitrogen top-dressing of 40 kg/ha at Growth Stage 8 reduced infection at least temporarily, delayed withering of the crop and increased yield by some 250 kg/ha. A nitrogen top-dressing at Growth Stage 7 or 8 became general practice.

7.5 DISCUSSION AND CONCLUSIONS

Drechslera oryzae is a pathogen of the generative stage of rice. Severity of the disease is negligible before Growth Stage 5 to 7; epidemics develop from then on. In susceptible cultivars, severity increased at a maximum rate of 0.2 unit per unit per day during the period between Growth Stage 5 to 7 and flowering.

Severity is enhanced by an imbalance between development of the rice plant during vegetative growth and during generative growth. Lush vegetative growth may cause deterioration of the plant during the generative stage when nutrients, especially nitrogen, are in short supply. Rice cultivars with an intermediate growing period seem more prone to disease than cultivars with either a short or a long period of development.

A few of these conditions have been met occasionally in the Wageningen Polder: (a) imbalance in development between the vegetative and the generative phases in the seasons after incorporation of organic matter; (b) imbalance between the vegetative and generative stages induced by heavy nitrogen top-dressing during vegetative growth only; (c) wet tillage and, therefore, insufficient aeration of the

soil, leading to reduction and possibly to formation of toxic substances (Ponnamperuma, 1965).

Measures that counteract the disease are as follows: (a) a nitrogen top-dressing in the generative phase; (b) dry tillage of the soil before the growing season; (c) temporary drainage during the growing season; (d) avoidance of incorporation of organic material by mowing with a flail mower and burning.

Environmental conditions in the Wageningen Polder do not favour balanced growth of the rice plant, and must be regarded as marginal. The rice cultivars grown until 1971 produced a good crop only when the adverse conditions experienced during vegetative growth had been counteracted by good farming.

8 Economic aspects of early senescence

8.1 FIELD TRIAL WITH ORGANIC MATTER, POTASSIUM, AND MANGANESE

In Section 7.4, the relation of incorporation of organic matter into the soil during tillage with disease severity in the subsequent season was emphasized. According to Baba (1958) and Tanaka & Yoshida (1970), rice is more susceptible to *D. oryzae* under conditions of deficiency in potassium or manganese. Potassium is fixed by Wageningen clay; the iron/manganese ratio is high (Section 2.2). This could mean that the rice crop is deficient in potassium as well as manganese, and that spray application of potassium sulfate and manganese sulfate could counteract the factors responsible for early senescence. Hence, organic matter, K and Mn were chosen as variables in a field trial laid out to simulate conditions favourable for development of the syndrome. The trial included measures to counteract disease.

Material and methods On 1 ha of rice crop about 5 tonnes of straw and 3 tonnes of root dry matter are produced per season. Under favourable conditions, when straw can be mown and burnt, about 4-5 tonnes organic matter is retained on the field; in rainy seasons when all straw has to be worked into the top soil 1 ha contains about 8 tonnes organic matter. It is difficult to incorporate this amount of straw in plots in a randomized block trial. A form of organic matter easier to handle was found in a waste product from rice milling consisting of small particles of rice grains and rice powder locally called 'grant'. 'Grant', chaff and straw were analysed chemically by the Laboratory for Soil and Crop Testing, Oosterbeek, the Netherlands (Table 25). 'Grant' contains much less minerals than straw. The difference between the two materials is particularly large for iron and manganese. By incorporating 'grant', a rapidly decomposing organic matter is brought into the top soil without enriching this as happens when rice straw is incorporated. 'Grant' is a readily available source of energy for anaerobic bacteria causing rapid and strong reduction in the top soil.

The trial was on a field left fallow during the previous season. The soil

Table 25. Chemical analysis of rice milling waste material ('grant'), chaff, and rice straw. Data from: Laboratory for Soil and Crop Testing, Oosterbeek, the Netherlands. (Values for P and K not available.)

	Ashes (%)	N (%)	Cellulose (%)	Cl (%)	SO ₃ (%)	NO ₃ (%)	
'grant'		1.33		0.00	0.30	0.02	
chaff	16.0	3.01	46.2	0.00	0.21	0.00	
straw	20.0	2.38	33.2	0.33	0.39	0.01	

	Co (mg/kg)	Cu (mg/kg)	Fe (mg/kg)	Mn (mg/kg)	Mo (mg/kg)	Pb (mg/kg)	Zn (mg/kg)
'grant'	0.04	2.5	13	10	0.68	1.0	20
chaff	0.10	2.3	319	225	2.11	0.1	16
straw		4.9	4197	420	1.14	4.5	53

was ploughed twice under dry conditions and puddled subsequently. The field was drained a few days before the organic matter was incorporated in the upper 5 cm of the soil in plots measuring 5 x 10 m. The doses applied were 0, 2.5, 5, and 10 tonnes per ha (0 treatments). The field was sown with cv. SML Temerin on the day of treatment with organic matter. Urea was given twice as topdressing of 50 kg/ha on Days 38 and 57 after sowing. The trial was laid down as a randomized block design with four replicates. On Day 60 the plots were split into four subplots with following treatments: no treatments; 20 kg/ha potassium sulfate (50 % K₂O); 20 kg/ha manganese sulfate (30 % Mn); 20 kg/ha potassium sulfate + 20 kg/ha manganese sulfate as foliar spray (M treatments). In this trial the condition of the crop, chlorosis of leaves, severity of D. oryzae infection, and blackening of roots was estimated on a range of dates. On Day 21 after sowing, plants were counted in 4 squares of 0.50 x 0.50 m each. The plots were harvested 130 days after sowing. Yield was determined and several characteristics of grain quality were measured (Table 26).

The data from plant counts and grain quality were processed by means of the analysis of variance (anova) for a split plot design. The data for leaf spots, chlorosis, and blackening of roots were analysed as described below (Prof. L.C.A. Corsten pers. commun., 1975). Leaf spots were assessed on 8 days with $n = 8 - 1 = 7$ successive intervals i ($i = 1, n$). For each pair of successive observations, the differences y_i between the observations were calculated. For each interval i these differences were added over all $4 \times 4 \times 4 = 64$ combinations

Table 26. Field trial with organic matter, potassium and manganese.

Schedule of observations												
date	67	67	67	67	67	68	68	68	68	68	68	68
days after sowing	0	17	20	32	47	60	67	72	87	98	126	130
growth stage	0	2	3	3	4	5	7	8	9	10.1	11.3	11.4
Sowing	+											
Crop												
plant counts (plants/m ²)	+											
crop condition (scale 0-9) ¹⁾	+											
Leaves												
leaf spots (o/oo) ²⁾	+											
chlorosis (% of leaf surface)	+											
Root system												
blackening (% healthy looking roots)	+											
Yield (kg/ha) ³⁾	+											
Grain quality												
crack (%)	+											
green (%)	+											
chalk (%)	+											
spotted (%)	+											
broken (%)	+											
moisture content (%)	+											
hectoliter weight (%)	+											

1) 0 = no plants; 8 = ideal crop condition; 9 = too dense

2) See section 7.3

3) at 14% moisture content

of treatments giving n sums $g_i = \sum y_i$. For each combination of treatments the differences y_i were multiplied by the corresponding values g_i and the resulting products $y_i g_i$ were added over all intervals i . The result is one value $b = \sum_{i=1}^n y_i g_i$ for each combination of treatments. In a single value, b expresses the whole set of observations of leaf spots for a specific combination of treatments, so there were 64 b values for leaf spots in this experiment which can be processed by anova (Table 27). There was a highly significant ($P \ll 0.001$) added variance component due to treatment with organic matter. No added variance

Table 27. Anova table for b values for leaf spots of *D. oryzae*.
Explanation of the experiment see text.

Source of variation	df	SS	MS	F _s
Blocks	3	3.0 exp 11	1.0 exp 11	3.58 ns
O treatments	3	79.9 exp 11	26.6 exp 11	95.43 ***
Remainder	9	2.5 exp 11	0.3 exp 11	
Total	15	95.6 exp 11		
M treatments	3	0.9 exp 11	0.3 exp 11	0.48 ns
M O interaction	9	70.8 exp 11	7.9 exp 11	11.87 ***
Remainder	36	23.9 exp 11	0.7 exp 11	
Total	48			
Grand total	63			

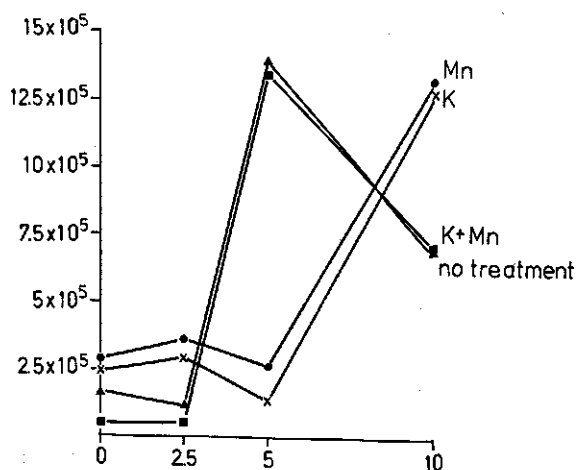

Figure 23. Differences in the amount of leaf spots for different treatments, expressed as b values; explanation see text.

Abscissa - Tons per ha of 'grant' incorporated into the top soil.
Ordinate - b values for leaf spots

component among M treatments could be demonstrated. There was, however, a highly significant interaction between treatments with organic matter and treatments with K and Mn. The b values for leaf spots averaged for different O and M treatments are shown in Figure 23. The interaction cannot be interpreted biologically. It is ignored in the following analysis which is restricted to the large effect of O treatments.

This analysis may serve as a tentative approach to interrelate two groups of data: (1) observations on growth and disease, and (2) observations on yield and quality of grain.

The sums of squares for treatment with organic matter were used to calculate the sums of products for all combinations of parameters. From these values the product moment correlation coefficients were calculated (Table 28).

Interpretation of the results A biological interpretation of the b values follows from Figures 24, 25, and 26. The number of leaf spots decreased with increasing amount of organic matter incorporated into the soil. The b values, averaged per O treatment, increased with increasing doses of organic matter. Therefore, b values and leaf spots are inversely related. The b values for chlorosis do not differ much for the lower three O treatments, but increase

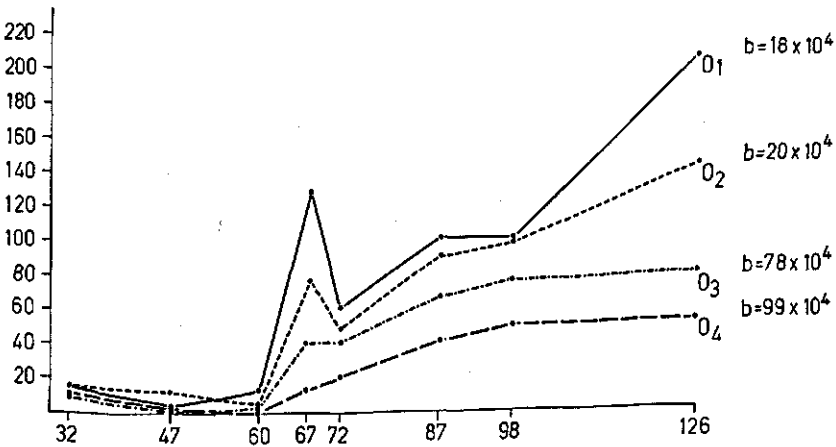

Figure 24. Relation between the amount of leaf spots and time for different treatments with organic matter.
 Abscissa - Days after sowing.
 Ordinate - Leafspots in per mil of leaf area infected.
 Entries - b values for leaf spots averaged over K and Mn treatments.

- O1 - no treatment
- O2 - 2.5 tons per ha 'grant'
- O3 - 5 tons per ha 'grant'
- O4 - 10 tons per ha 'grant'

Table 28. Product moment correlation coefficients for observations on growth, disease, and grain. Quality characteristics considering incorporation into the topsoil of different amounts of easily decomposable organic matter. Explanation see text.

	Plant counts (plants/m ²)	b values leaf spots (%)	b values chlorosis (%)	b values healthy looking roots (%)	yield (kg/ha)	bulk-density (kg)	moisture content (%)	cracked (%)	broken (%)	green (%)	chalk (%)	spotted (%)
Plant counts	1.0											
b values leaf spots	-.98(1)	1.0										
" chlorosis	-.82	.71	1.0									
" healthy looking roots	-.94	.87	.96	1.0								
yield	-.92	.93	.63	.76	1.0							
bulk-density	-.77	-.73	-.62	-.67	-.91	1.0						
moisture content	-.30	.16	.75	.60	-.04	.01	1.0					
cracked	-.37	.29	.65	.60	-.03	.15	.91(5)	1.0				
broken	-.00	-.08	.32	.23	-.41	.52(4)	.81	.92	1.0			
green	-.91(2)	-.89	-.69	-.79	-.99	.95(4)	-.03	.01	.39	1.0		
chalk	-.99	.98	.81	.93	.94	-.81	.27	.32	-.07	-.93(3)	1.0	
spotted	.00	.76	.66	.71	.93	-.98	.02	-.12	-.50	-.97	.84	1.0

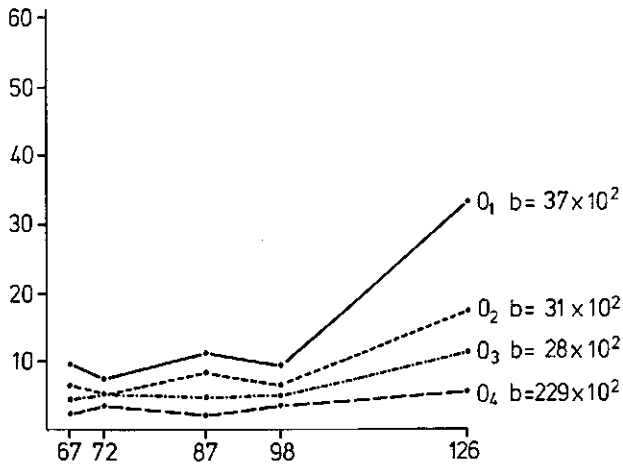

Figure 25. Relation between chlorosis of rice leaves and time for different treatments with organic matter.

Abscissa - Days after sowing.

Ordinate - Chlorosis in per cent of leaf area.

Entries - b values for chlorosis.

O treatments, see Fig. 24.

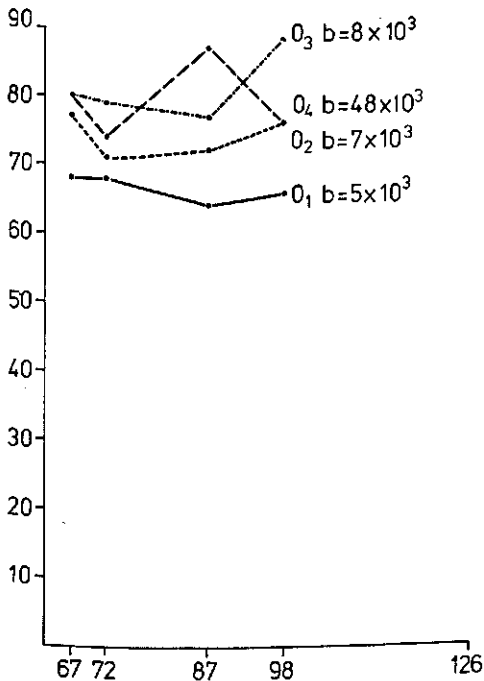

Figure 26. Relation between healthy looking roots and time for different treatments with organic matter.

Abscissa - Days after sowing.

Ordinate - Per cent of healthy looking roots.

Entries - b values for healthy looking roots.

O treatments, see Fig. 24.

sharply with the highest treatment. Chlorosis decreases with increasing amounts of organic matter. As for leaf spots, *b* values and chlorosis are presumably inversely related. The relation between the proportion of healthy looking roots and the *b* values is indeterminate; the highest O treatment shows interaction with the lower O treatments; in view of Table 28 a direct relation is assumed. Figure 27 gives the observations on crop condition. The interaction prohibits any biological interpretation of the *b* values.

The number of plants per unit area decreased with increasing O treatment (Fig. 28). This provides a basis for the interpretation of the correlation coefficients of Table 28. In this table, 5 groups of coefficients, which seem particularly interesting, are framed.

1. In this experiment a thin crop is healthier than a normal crop. Apparently, incorporating 'grant' into the top soil not only caused reduction processes and production of toxic substances, but also causes a certain amount of minerals to become available over the growing season after the population of anaerobic organisms using 'grant' as source of energy dies down. These minerals are then utilized by the surviving plants. In plots with a thin healthy crop, yield was higher than in plots with a more dense but diseased crop. Bulk density and yield are inversely related indicating that the grains of high yielding plots are loosely packed within the glumes.

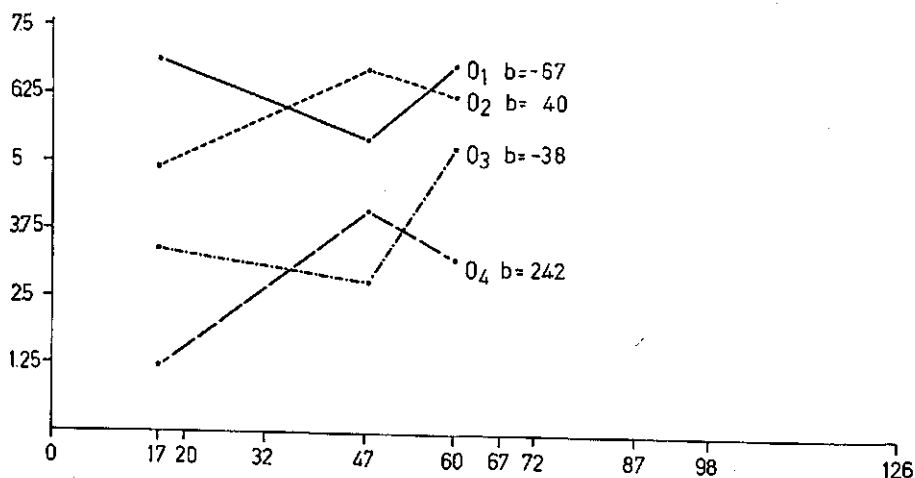

Figure 27. Relation between crop condition and time for different treatments with organic matter.

Abscissa - Days after sowing.

Ordinate - Crop condition on a scale of 1 to 9.

Entries - *b* values for crop condition.

O treatments, see Fig. 24.

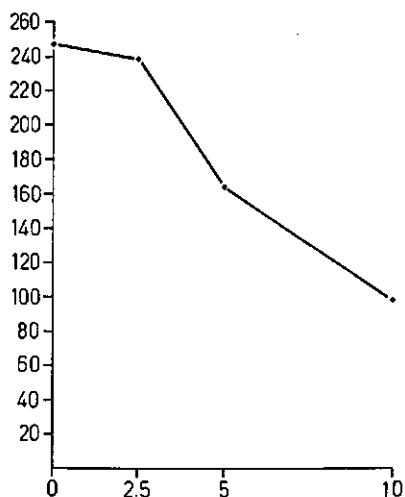

Figure 28. Relation between the number of rice plants per unit area and organic matter ('grant') incorporated into the top soil.

Abscissa - Tons per ha of 'grant' incorporated into the top soil.

Ordinate - Number of plants per m².

2. In plots with a thin crop grains remained green longer than in plots with a more dense crop. 'Chalk', which stands for partially opaque grains of low market value, increases with increasing crop density.

3. The inverse relation between 'green' and 'chalk' also follows from this group of coefficients. 'Green' was accompanied by spotting of the dehusked grain.

4. The relations result in high correlation coefficients for yield with green, chalk and spotted grains.

5. Finally, a high moisture content goes together with a large amount of broken and cracked grains.

Conclusions Two conclusions can be drawn by this experiment. First, the 'normal' crop showed 'early senescence', whereas the thinned crop was healthy. The thinned crop yielded more rice than the normal crop. Hence the advice should be given to reduce the amount of seed used per ha, creating a thin crop which should then be treated with fertilizers, especially nitrogen, throughout the growing season.

A number of field trials, not further described here, corroborated that a topdressing with nitrogen in the generative phase of the plant suppressed chlorosis and infection by *D. oryzae*; yield was increased. The outcome of these trials caused the management to introduce a third nitrogen

topdressing at growth stage 8 to 9. In further trials, manganese and potassium did not increase yield or suppress the syndrome.

However, a second conclusion is that the quality - large, whole, white, translucent grains - decreases with increasing yield. A small increase in the proportion of green or broken grains has a large influence on the amount of high-quality rice products with high market value that are obtained in the rice-mill. A remedy for 'early senescence' should not only be examined in terms of yield increase but also in terms of grain quality. Grain quality largely determines the economic results of vertically integrated rice production in a unit like S.M.L. Further research with respect to grain quality is strongly recommended.

8.2 RELATION OF YIELD, INFECTION BY *D. ORYZAE*, CHLOROSIS AND BLACKENING OF ROOTS

The influence of early senescence on yield was analyzed by pooling the observations of 7 field trials with fertilizers. In these trials infection by *D. oryzae*, chlorosis and blackening of roots was observed for each plot on a range of dates; 389 plots - all 50 m² - were harvested. The yield was regarded as dependent variable; disease severity, chlorosis and discoloration of roots observed during Growth Stages 9 to 10.1 were considered to be independent variables in a regression analysis based on graphic approximations by the method of Ezekiel and Fox (1970) (Section 3.2.1.). The results of this analysis are given in Figure 29. An increase in chlorosis from 1 to 25 % causes yield to decrease by about 5 kg per plot of 50 m², a decrease equivalent to 1000 kg/ha. An increase of severity of infection by *D. oryzae* of 25 % causes a loss in yield of about 3.5 kg per plot or 700 kg/ha. An increase in root discoloration between 0 and 50 % causes yield to decrease by about 4.5 kg per plot or 900 kg/ha.

A yield increase of up to 50 % can be expected by suppressing early senescence.

8.3 SYNTHESIS

Early senescence, the disease of rice described and analyzed in the foregoing chapters, is not uncommon in Surinam. In its severe form it seems to be restricted to the Wageningen Polder. Early senescence frequently occurred during the early years of the Project in a time of unsettled soils and in-

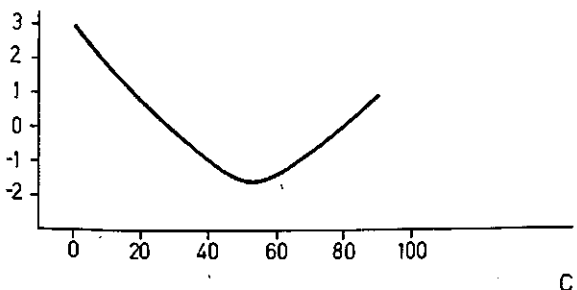
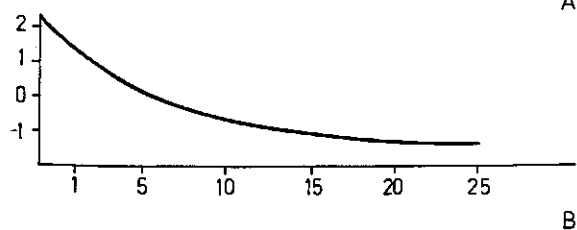
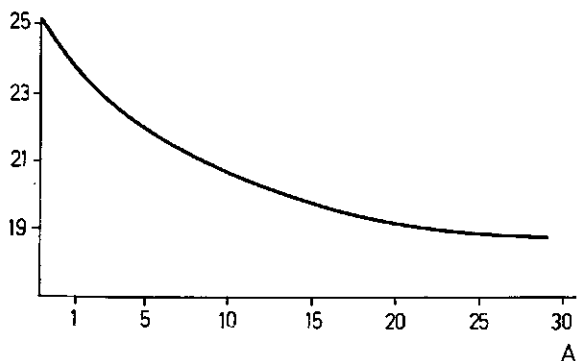

Figure 29. Relation between yield, severity of infection by *Drechslera oryzae*, chlorosis, and blackening of roots, following the graphic approximation by the method of Ezekiel and Fox (1970).

a - Abscissa - Chlorosis in per cent of leaf area.

Ordinate - Estimated yield in kg per 50 m².

b - Abscissa - Severity of infection by *D. oryzae*.

Ordinate - Correction of yield estimated from the curve in a (kg per 50 m²).

c - Abscissa - Per cent of blackened roots.

Ordinate - Correction of yield estimated from the curve in a (kg per 50 m²).

Note that at values above 50 % blackened roots the rice plant compensates for loss of root activity by the formation of new adventitious roots (matted roots).

experience in growing of rice under conditions prevalent in the young coastal plain of Surinam. Later, severe crop losses occurred only in seasons where good tillage and crop management were not possible because of environmental conditions. However, the symptoms of early senescence - though less severe - were found in every season, on many fields. There are notable differences in the syndrome between the Wageningen Polder and the Prins Bernhard Polder in

New Nickerie or the medium sized farms in the leased plots adjacent to the Wageningen Project. Early senescence seems to be more severe in a system of large scale farming where attention is shifted from optimization of growing conditions in the field to optimization of the use of capital goods.

Early senescence can be remedied by the following measures:

(1) breeding rice cultivars with a short growing period to allow better use of the dry periods for seedbed preparation; (2) selection of rice under Wageningen conditions in the Wageningen Polder, or alternatively, by simulating the Wageningen conditions at the Rice Breeding Station in the Prins Bernhard Polder; (3) good seedbed preparation, giving the crop a good start on a well aerated soil with a low content of organic matter; (4) careful management of nitrogen application, providing the crop with this important nutrient throughout the season.

Early senescence is mainly associated with factors of soil and crop management and cannot be economically controlled with fungicides.

Note: Since this investigation was concluded, a number of cultivars with a shortened growing period was released.

Summary

Fungal diseases in the Wageningen Polder, Surinam (South America) caused crop losses up to 20 % in some years. Earlier attempts to solve the problem were not successful (1.1). A phytopathological survey revealed that *Drechslera oryzae* was the major pathogen of rice (1.4).

In the Wageningen Polder two rice crops are grown each year. The utilization of land amounted to 180 % in 1975 (2.3). Wageningen soil is a heavy clay (2.2). All major operations of rice production in the Wageningen Polder have been mechanized. Different methods for tillage and seedbed preparation have been developed for various conditions of soil and weather, with results varying from a fine crumbly seedbed (dry tillage) to a soft muddy seedbed with a virtually impermeable top layer and a high content of organic matter (wet tillage) (2.3). Yields obtained from wet tilled fields were lower than yields obtained from dry tilled fields (3.2). Yield was inversely proportional to rainfall during tillage and also to rainfall during the final stages of ripening and harvest (3.3.2).

The Wageningen Polder is one single unit of cultivated land within a vast swamp. In that situation no changes important for dispersal and survival of wind-borne leaf-infecting pathogens of rice occur. Inoculum of these pathogens is always present (4.2).

To facilitate field observations, Feekes' scale for growth stages in cereals was adapted to rice (4.3.4). The scale was used to express the rhythm of development of the rice plant (4.3.5).

The syndrome of rice in the Wageningen Polder includes the following symptoms: discoloration of leaves, leaf spots, premature ripening of the crop, sterility of flowers, root decay, local blackening of roots, and matted roots (5.2; 5.3). These symptoms occur during the reproductive phase of the rice plant. Rice in the Wageningen Polder suffers from early and accelerated senescence. Infection by *Drechslera oryzae* is considered to be only one of the symptoms in the syndrome

(5.4). A similar syndrome is known in Japan as 'akiochi'. Akiochi is regarded as a nutritional disorder. It is presumed that early senescence of rice in the Wageningen Polder is related to unbalanced crop nutrition too (5.5).

Drechslera oryzae forms only a few spores in spots on green turgescence rice leaves. Abundant sporulation is seen when the leaf tissue around the spots has turned yellow (6.1.2). The nutrient medium most suitable for spore production was malt agar. Best results were obtained with incubation for 2 weeks under diffuse daylight supplemented by continuous fluorescent light. Large numbers of spores could also be grown on sterilized dehusked unpolished rice (6.1.4).

Drechslera oryzae is a fungus imperfectus belonging to the Dematiaceae. The perfect stage known as *Cochliobolus miyabeanus* has never been found in the Wageningen Polder (6.2.1).

Drechslera isolates have morphologic characteristics determined by the rice cultivar on which they grow (6.2.2). Germination of conidia of *D. oryzae* is stimulated by guttate from the rice plant (6.3).

Seedling inoculation as a technique to assess cultivar susceptibility was rejected (6.4.1). The method for inoculating the sheaths developed by Sakamoto (1951) was used to define and number stages of invasion by the fungus (F scale) and reaction of the host (H scale) (6.4.2). In an experiment with 12 rice cultivars both F and H indicated that with age the rice plants became increasingly susceptible to infection by *D. oryzae* (6.4.3). In the Wageningen Polder *Drechslera oryzae* is a pathogen of the generative stage of rice (7.3). Between 1954 and 1969, a period covering 32 cropping seasons, epidemics of brown spot caused by *D. oryzae* occurred in 12 seasons. Analysis of past epidemics shows that severity of the disease is enhanced by imbalance between development of the rice plant during vegetative growth and during the generative phase. Lush growth in the vegetative phase may cause deterioration of the plant during the generative phase when nutrients, especially nitrogen, are in short supply (7.4). Rice cultivars with an intermediate growing period seem more prone to disease than cultivars with either a short or a long period of development (7.3).

A field trial simulating conditions favourable for development of the syndrome showed that early senescence should not only be looked at in terms of yield decrease but also in terms of decrease in the quality of grain. Quality rather than yield of grain is the economic factor in a vertically integrated rice production unit like SML (8.1). The influence of early senescence on yield

should however, not be neglected. Analysis of trials showed that a yield increase up to 50 % could be expected by suppressing early senescence (8.2). Early senescence of rice seems to be more severe in a system of large-scale farming. In contrast to one-family farms, large-scale farming emphasizes optimal use of capital goods rather than optimal growing conditions (8.3). Early senescence of rice can be remedied by a series of measures related to breeding and by good farming practices.

Samenvatting

Het hier gerapporteerde onderzoek had tot doel het probleem van schimmelziekten in de Wageningen Polder in Suriname te analyseren. Uit verslagen en rapporten van de Stichting voor de Ontwikkeling van Machinale Landbouw in Suriname (SML) blijkt dat schimmelziekten in sommige jaren opbrengstderving tot 20 % tot gevolg hadden. Pogingen om het probleem op te lossen hadden geen succes (1.1).

Bij de aanvang van het onderzoek werden de in de Wageningen Polder op rijst voorkomende schimmels geïnventariseerd. Het belangrijkste pathogeen was *Drechslera oryzae* (1.4).

In de Wageningen Polder wordt per jaar twee maal rijst verbouwd. De intensiteit van grondgebruik was in 1975 180 % (2.3). De Wageningen Polder is aangelegd op zware klei (2.2). De rijstbouw is zoveel mogelijk gemechaniseerd. De methode van grondbewerking wordt aangepast aan het weer en aan de conditie van de grond. Het resultaat van grondbewerking varieert met de toegepaste methode van een fijn kruimelig zaaibed (droge grondbewerking) tot een slap modderig zaaibed waarvan de bovenlaag praktisch ondoorlaatbaar is (natte grondbewerking) (2.3). Velden die nat bewerkt waren gaven een lagere opbrengst dan droog bewerkte velden (3.2). De opbrengst is omgekeerd evenredig met regenval tijdens de grondbewerking en met regenval tijdens het laatste stadium van afrijping en de oogst (3.3.2).

De Wageningen Polder kan worden beschouwd als één gesloten produktie eenheid in een immens moerasgebied. Binnen dat systeem komen geen veranderingen voor belangrijk voor de verspreiding en overleving van anemochore bladpathogenen. Inoculum van deze pathogenen is altijd aanwezig (4.2).

Om waarnemingen aan rijstplanten kort te kunnen beschrijven werd Feekes' schaal voor de ontwikkelingsstadia van granen aangepast aan rijst (4.3.4). Deze schaal werd gebruikt om het ontwikkelingsritme van de rijstplant te illustreren (4.3.5).

De ziekte van rijst in de Wageningen Polder is gekenmerkt door de volgende symptomen: verkleuring van de bladeren, bladvlekken, noodrijpheid van het gewas, steriliteit van de rijstbloempjes, wortelrot, plaatselijk zwartkleuring van wortels en vorming van een wortelmat (5.2; 5.3). Deze symptomen verschijnen tijdens de reproductieve fase van de rijstplant. Het rijstgewas in de Wageningen Polder lijdt aan vroege en versnelde veroudering. Infectie door *Drechslera oryzae* wordt beschouwd als een onderdeel en niet meer dan een onderdeel van de groep van symptomen die tezamen het syndroom van vroege veroudering vormen (5.4). Een syndroom dat hiermee gelijkenis vertoont staat in Japan bekend als 'akiochi'. Akiochi wordt beschouwd als een fysiologische ziekte ten gevolge van een voedingsstoornis. Aangenomen wordt dat vroege veroudering van rijst in de Wageningen Polder eveneens verband houdt met onevenwichtige voeding van het gewas (5.5).

Drechslera oryzae vormt in vlekken op groene turgescente rijstbladeren slechts weinig sporen. Grote aantallen sporen worden gevormd als het bladweefsel rondom de vlekken verkleurd is (6.1.2). Mout-agar was het meest geschikte cultuurmedium voor de produktie van sporen. De beste resultaten werden verkregen met incubatie gedurende 2 weken in diffuus daglicht aangevuld met continue belichting door fluorescentie buizen. Grote aantallen sporen konden ook worden gekweekt op steriele gepelde, niet geslepen rijstkorrels (6.1.4).

Drechslera oryzae is een fungus imperfectus behorend tot de Dematiaceae. Het perfecte stadium; bekend als *Cochliobolus miyabeanus* is in de Wageningen Polder nooit gevonden (6.2.1).

Drechslera isolaties bezitten morfologische kenmerken en eigenschappen die bepaald worden door de rijst cultivar waarop ze groeien (6.2.2). De kieming van conidiosporen van *D. oryzae* wordt gestimuleerd door guttaat van de rijstplant (6.3).

Inoculatie van rijstkiemplanten kan niet worden gebruikt om de gevoeligheid van cultivars te testen (6.4.1). Stadia van infectie door de schimmel en stadia van reactie van de waard werden gedefinieerd en van schaalwaarden (F schaal en H schaal) voorzien met behulp van de bladschede inoculatie techniek ontwikkeld door Sakamoto (1951) (6.4.2). Bij een proef met 12 rijst cultivars bleek uit de ontwikkeling van zowel F als H, dat de gevoeligheid van de rijstplant voor infectie door *D. oryzae* toeneemt met de leeftijd van de plant (6.4.3).

In de Wageningen Polder is *Drechslera oryzae* een pathogeen van de generatieve fase van de rijstplant (7.3). Tussen 1954 en 1969 werd 32 maal rijst verbouwd; 12 maal trad een epidemie van *D. oryzae* op.

Analyse van deze epidemieën toont aan dat de ziekte wordt bevorderd door verstoring van het evenwicht tussen de ontwikkeling van de plant in de generatieve en de ontwikkeling in de vegetatieve fase van de groei. Geïle groei in de vegetatieve fase kan de ontwikkeling in de generatieve fase nadelig beïnvloeden, als voedingsstoffen, en vooral stikstof, in onvoldoende mate voorhanden zijn (7.4). Rijst cultivars met een middellange groeiperiode blijken gevoeliger voor de ziekte dan cultivars met een langere of kortere groeiperiode (7.3).

Uit een veldproef waarin de omstandigheden, die de ontwikkeling van vroege veroudering begunstigen, werden gesimuleerd, bleek dat het syndroom niet alleen benaderd moet worden vanuit het gezichtspunt van opbrengstderving doch evenzeer uit het oogpunt van afname van de kwaliteit van de rijstkorrel. Korrelkwaliteit is minstens even belangrijk als opbrengst voor de economische bedrijfsresultaten van een vertikaal geïntegreerd rijstproductiebedrijf zoals de SML (8.1). De invloed van vroege veroudering mag niet worden onderschat. Uit de analyse van een aantal veldproeven volgt dat vermindering van vroege veroudering een opbrengststijging tot 50 % tot gevolg kan hebben (8.2). In vergelijking met de "kleinlandbouw" schijnt vroege veroudering ernstiger vormen aan te nemen in een systeem van "grootlandbouw" waar de aandacht wordt verlegd van optimalisering van groeivoorwaarden in het veld naar optimalisering van het gebruik van kapitaalgoederen (8.3).

Vroege veroudering van rijst kan worden tegengegaan en bestreden door een serie maatregelen die verband houden met veredeling en met een goede verpleging van het gewas (7.5; 8.3).

References

- Alberda, Th., 1953. Growth and root development of lowland rice and its relation to oxygen supply. *Plant Soil* 5; 1: 118.
- Baba, I., 1958. Nutritional Studies on the occurrence of *Helminthosporium* leaf spot and "Akiochi" of the rice plant. *Bull. Nat. Inst. Agr. Sci. Series D*; 7: 1-158.
- Baba, I. and T. Harada, 1954. Akiochi, Akagare and Straighthead. In: *Physiological diseases of rice plant in Japan*. Min. Agr. and For. Japan. 1954: 1-50.
- Bergman, H.F., 1959. Oxygen deficiency as a cause of disease in plants. *Bot. Rev.* 25; 3: 417-485.
- Brinkman, R., 1967. A rapid reconnaissance of the main clay mineral provinces in the Guyanas. *Geologie en Mijnbouw* 46: 446-452.
- Broekhuizen, S., 1961. Het observatieproefveld voor de veenkoloniën in 1961. In: *Tienjarenplan voor het graanonderzoek 1961. Verslag over het achtste jaar*. Ned. Craancentrum.
- Bunting, A.H. and D.S.H. Drennan, 1966. Some aspects of the morphology and physiology of cereals in the vegetative phase. In: *The growth of cereals and grasses*. F.L. Milthorpe and J.D. Ivins, Eds. London.
- Chang, T.T., 1968. Growth stages of the rice plant. *Int. Rice Res. Inst. Field experiment workshop*. February 20.
- Dassen, M.H.E., 1967. Onderzoek naar een stadiumgevoeligheid van *Oryza sativa* L., voor aantasting door *Cochliobolus miyabeanus* (Ito et Kuribayashi) Drechsler. *Stichting Ontw. Mach. Landb. Suriname. Intern rapport*.
- De Wit, Th.P.M., 1960. The Wageningen Rice Project in Surinam. Thesis Wageningen, Neth.
- Dirven, J.G.P., I.G.H. Dulder and W.Ch. Hermelijn, 1960. De braakvegetatie op rijstvelden in Nickerie. *De Sur. Landbouw* 8; 1.
- Drechsler, C., 1934. Phytopathological and taxonomic aspects of *Ophiobolus*, *Pyrenophora*, *Helminthosporium*, and a new genus, *Cochliobolus*. *Phytopathology* 24: 953-985.
- Ellis, M.B., 1971. *Dematiaceous Hyphomycetes*. Commonwealth Mycological Institute, Kew, England.
- Ellis, M.B. and P. Holliday, 1971. *Cochliobolus miyabeanus*. C.M.I. Descriptions of Pathogenic Fungi and Bacteria No. 302. Commonwealth Mycological Institute, Kew, England.
- Ezekiel, M. and K.A. Fox, 1970. *Methods of correlation and regression analysis*. 3rd edition 1959, 7th printing 1970. John Wiley & Sons Inc. New York.
- Federation of British Plant Pathologists, 1973. A guide to the use of terms in plant pathology. *Phytopath. pap. no. 17*.
- Feekes, W., 1941. De tarwe en haar milieu. *Versl. techn. tarwe comm.* 17: 560-561.
- Heeres, J., 1966. Verslag van het Schimmelonderzoek in de Wageningerpolder. October 1965-Februari 1966. *Stichting Ontw. Mach. Landb. Suriname. Intern rapport*.
- Inada, K., 1967. Physiological characteristics of rice roots, especially with the viewpoint of plant growth stage and root age. *Bull. Natl. Agr. Sci.* (Japan) series D, no. 16.

- Ito, S. and K. Kuribayashi, 1927. Production of the ascigerous stage in culture of *Helminthosporium oryzae*. *Ann. Phytopath. Soc. Japan* 2: 1-8.
- Ivanoff, S.S., 1963. Guttation injuries of plants. *Bot. Rev.* 29: 202-229.
- Kerling, L.C.P., 1948. Ontwikkeling en periodiciteit bij rijst. *Landbk. Tijdschr.* 60: 150-158.
- Landsberg, H.E., H. Lippmann, K.H. Paffen and C. Troll, 1966. World maps of climatology. Springer, Berlin.
- Large, E.C., 1954. Growth stages in cereals, illustration of the Feekes scale. *Plant Pathol.* 3: 128-129.
- Lindeman, J.C., 1953. The vegetation of the coastal region of Suriname. In: *The vegetation of Suriname 1; part 1: 1-135.*
- Matsubayashi, M., 1965. Theory and practice of growing rice. Fuji Publ. Co. Tokyo.
- Matsushima, S., 1967. Crop science in rice. Fuji Publ. Co. Tokyo.
- Meteorologische Dienst Suriname, 1968. Klassificatie der seizoenen. *Rapporten Serie 2 no. 6.*
- Okajima, H., 1965. Environmental factors and nutrient uptake. In: *The mineral nutrition of the rice plant. Proc. Symp. Int. Rice Res. Inst. 1964.* John Hopkins Press, Maryland, U.S.A.
- Ou, S.H., 1965. A proposal for an international program for research on the rice blast disease. In: *The rice blast disease. Proc. Symp. Int. Rice Res. Inst. 1963.* John Hopkins Press, Maryland, U.S.A.
- Ou, S.H., 1972. Rice diseases. Commonwealth Mycological Institute, Kew, England.
- Padmanabhan, S.Y., 1973. The great Bengal famine. In: *Annual review of phytopathology* 11: 11-26.
- Padmanabhan, S.Y. and D. Ganguly, 1954. Relation between the age of rice plant and its susceptibility to *Helminthosporium* and blast diseases. *Proc. Indian Acad. Sci. (B)* 39: 44-50.
- Perumal, S., 1963. Some aspects of the growth stages of the rice plant. *Malayan Agriculturist* 3: 38-45.
- Ponnamperuma, F.N., 1965. Dynamic aspects of flooded soils and the nutrition of the rice plant. In: *The mineral nutrition of the rice plant. Proc. Symp. Int. Rice Res. Inst. John Hopkins Press, Maryland, U.S.A.*
- Sadasivan, T.S., 1959. The problem of the blast disease of rice. *Proc. Indian Ac. Sci. B* 49: 1-6.
- Sakamoto, M., 1951. On the new method of inoculation of rice plants with the blast fungus *Piricularia oryzae* Cav. *Rep. Tohoku Univ. Inst. Agr. Res.* 1-2: 15-23.
- Scheltema, W., 1974. Puddling against dry plowing for lowland rice culture in Surinam: effect on soil and plant, and interactions with irrigation and nitrogen dressing. *Agric. Res. Rep.* 828. Pudoc, Wageningen, Neth.
- Sokal, R. and F.J. Rohlf, 1969. *Biometry.* Freeman & Comp. San Francisco, U.S.A.
- Sokal, R. and H.A. Sneath, 1963. *Principles of numerical taxonomy.* Freeman & Comp. San Francisco, U.S.A.
- Solangi, G.R., R.B.M. Abbasi and M. Tanveer, 1970. Reaction of paddy varieties to *Helminthosporium oryzae*. *J. Agr. Res. (Punjab)* 8; 3: 318-320.
- Sprague, R., 1950. *Diseases of cereals and grasses in North America.* Ronald Press, New York.
- Stocking, C.R., 1956. Guttation and bleeding. In: *Encyclopedia of plant physiology.* W. Ruhland ed. III: 489-502.
- Strickland, R.W., 1968. The effect of drainage on physiological disorders of rice grown on the sub-continental plains of the Adelaide River, N.T. *Austr. J. Exp. Agr. An. Husb.* 8: 213-222.
- Stubbs, R.W. and Th.P. de Wit, 1957. Ziekten van rijst in het Wageningse Polder-areaal. *Stichting Ontw. Mach. Landb. Suriname. Intern Rapport.*

- Subba-Rao, N.S. and S. Suryanarayanan, 1957. Exosmosed substances on the leaf blade of rice (*Oryza sativa* L.). *Curr. Sci.* 26: 186-187.
- Subramanian, C.V. and B.L. Jain, 1966. A revision of some graminicolous Helminthosporia. *Curr. Sci.* 14: 352-355.
- Suryanarayanan, S., 1956. The "blast" disease of rice (*Piricularia oryzae* Cav.). *J. Madras Univ. B* 26: 649-657.
- Takahashi, Y., 1967. Nutritional studies on development of Helminthosporium leaf spot. In: Symposium on rice diseases and their control by growing resistant varieties and other measures. Agr. For. and Fisheries Res. Council, Min. Agr. and Forestry, Japan.
- Takyima, Y., 1963. Studies on behaviour of the growth inhibiting substances in paddy soils with special reference to the occurrence of root damage in the peaty fields. *Bull. Nat. Inst. Agr. Sci.* 1963: 238-252.
- Tanaka, A., 1965. Examples of plant performance. In: The mineral nutrition of the rice plant. Proc. Symp. Int. Rice Res. Inst. John Hopkins Press, Maryland, U.S.A.
- Tanaka, A. and S. Yoshida, 1970. Nutritional disorders of the rice plant in Asia. *Int. Rice Res. Inst. Tech. Bull.* nr. 10.
- Tanaka, T., 1922. New Japanese Fungi. Notes and Translations XI. *Mycologia* 14: 81-89.
- Ten Have, H., 1967. Research and breeding for mechanical culture of rice in Surinam. Thesis Wageningen, Neth.
- United Nations' Statistical Yearbook 1974.
- Van Beers, W.F.J., 1961. Een oriënterend onderzoek naar de oorzaken en de midde-len ter voorkoming van schimmelaantasting bij rijst in het "Wageningen-projekt" Suriname. Stichting Ontw. Mach. Landb. Intern Rapport.
- Van Breda de Haan, J., 1900. Vorläufige Beschreibung von Pilzen bei tropischen Kulturpflanzen beobachtet. *Bull. Inst. Bot. Buitenzorg* 6: 11-13.
- Van Dijk, H.N., 1940. Mechanische rijstcultuur. Amsterdam.
- Van Hoof, H.A., R.W. Stubbs and L. Wouters, 1962. Beschouwingen over hoja blanca en zijn overbrenger *Sogata Oryzicola* Muir. *De Sur. Landb.* 10: 3-18.
- Van Raalte, M.H., 1941. On the oxygen supply of rice roots. *Ann. Bot. Gardens Buitenzorg* 51: 43-57.
- Vorraurai, S. and P. Giatgong, 1971. Pathogenic variability and cytological studies of *Helminthosporium oryzae* Brede de Haan, the organism causing brown spot disease of rice. *Int. Rice Comm. News Letter* 20; 1: 18-23.
- Walter, H., 1958. Klimatypen dargestellt durch Klimadiagrammen. *Geographisches Taschenbuch* 1958/1959: 540-543.
- Yamada, N., 1959. Some aspects of the physiology of Bronzing. *Int. Rice Comm. News Letter* 8; 3: 11-16.
- Zadoks, J.C., T.T. Chang and C.F. Konzak, 1974. A decimal code for the growth stages of cereals. *Eucarpia Bull.* 7.

Appendix A. Collection of rice cultivars and selection lines.

Name	Growing period ₁ (days)	Name	Growing period (days)
1 CI 7787	92	102 221/BCIV/I/178/13	133
2 CI 8985	92	103 221/BCIV/I/178/3	133
3 CI 1561-1	78	104 221/BCIV/I/45/8	133
4 CI 8970 (purple)	78 *	105 Zuiho	94
4 CI 8970 (purple)	92	106 Kanto 53	78 *
5 CI 8970 (straw)	78 *	106 Kanto 53	95
5 CI 8970 (straw)	92	107 Gimmasari	94
6 CI 5309	92	108 Norin 18	86 *
7 PI 180061	88	108 Norin 18	94
8 PI 201902	95	110 Hakkoda	95
11 Te-tep	114	115 Norin 22	78
12 Takudan	114	116 Koshiji wase	78
13 Usen	101	116 Koshiji wase	86
14 Chokoto	101	117 Norin 17	78
16 Kanto 51	95	117 Norin 17	86
17 Ishikari shiroke	78 *	121 Miho-nishiki	78
17 Ishikari shiroke	95	144 Dharial	78
18 Homare Nishiki	95	144 Dharial	88
20 Norin 22	78 *	145 Hashikalmi	78
20 Norin 22	95	145 Hashikalmi	85
22 Norin 20	78 *	149 Panbira	88
22 Norin 20	88	153 Da-31	101
22 Norin 20	95	155 Bluebonnet	101
30 Kao-chio-liu-chou	88	157 K 1	129
32 Taichung Ti-chio-wu- chien	101	158 Mekeo white	129
33 Custugulcule	88	161 Toentoeng	129
34 Natala	95	162 52/16-0-2	129
35 Kanto 51	95	163 Bengawan	129
36 Nung-lin 21	78 *	164 Tjere Mas	129
38 Kung-shan Wu-shen-ken	94	165 Peta	129
46 D 25-4	116	177 FK 165	129
49 M-302	116	179 R 75	97
51 H-5	116	180 Ignape Catelo	97
53 H-105	117	180 Ignape Catelo	101
54 H-501	117	184 Taipei 127	105
60 Cesariet	95 *	185 Taipei 306	106
60 Cesariet	109	187 Taichung 150	106
61 Fanny	78 *	188 Taichung 155	106
61 Fanny	95	190 Chianung 242	106
70 T 141	133	191 Chianung Yu 280	113
71 PTB 10	95	192 Chianan 2	113
82 CO 30	84 *	193 Tainan 3	113
82 CO 30	95	194 Kaosiung 24	106
90 No. 10022	133	195 Kaosiung 64	106
91 No. K-60	133	196 Taichung 170	106
96 S. 67	95	198 Kaosiung Ta-Li-Chin-Yu	92
98 221/BCIV/I/178/6	133	200 I-kung-Pao	92
99 221/BCIV/I/178/9	133	201 Taitung Woo-Tsan	101
101 221/BCIV/I/178/11	133	202 Tsai-Yuan-Chon	101
		203 Woo-Gen	97

Appendix A, continued

Name	Growing period (days)	Name	Growing period (days)
203 Woo-Gen	101	404 SML 352 (Matapi)	129
212 Sapan Kwai 3	97	405 SML 81 b (Magali)	133
212 Sapan Kwai 3	101	406 SML 13/227	135
218 Zenith	127	408 Taichung native 1	93
221 CI 9402	101	409 SML 140/10 (Apikalo)	133
222 Sunbonnet	106	410 SML 467 (Apura)	135
223 Bluebonnet 50	106	411 SML 242 (Alupi)	133
224 Fortuna	106	412 D 52/27	125
225 Lacrosse	92	413 SML 757	141
227 Texas Patna	106	414 Vegold	85
228 Calrose	92	415 Arkrosse x Bluebonnet	102
229 Caloro	79	417 SML 359/4 (Temerin)	133
229 Caloro	92	418 BG 79	125
230 Blue rose	92	420 40c/27b	125
237 Nang Quot	101	421 Bluebonnet 50	113
242 Samo Ran	106	422 Bengawan	125
242 Samo Ran	113	423 SML 508	130
243 Puang Ngeon	113	424 SML 140/5 (Tapuripa)	129
256 Ta-poo-cho-2	101	425 BG 6044	113
258 Mo-R-500 x Nato	92	426 FB 76	141
400 SML 508	125	427 Peta	125
401 CI 9453 x CI 9187	125	428 BG 6047	114
402 SML 467 (Apura)	133	431 Skrivimankoti	141
403 SML 56/5 (Washabo)	125	432 Holland	140

* The cultivar ripened irregularly and was harvested on several days.

1) The growing period is given for the spring sown crop 1966.

Appendix B. Characteristics of Drechslera isolates grown on agars. Incubation period two weeks under fluorescent light (Section 6.1.4). For origin of isolates, see Table 17.

Properties	Nutrient agar	Variable	Isolate		
			1	2	3
Number of growth rings	OA ¹⁾	1	3	0	3
	PDA	2	1	0	3
	MA	3	1	0	3
Number of white patches	OA	4	0	0	0
	PDA	5	0	0	1
	MA	6	0	0	0
Number of spores in 0.9 mm ³	OA	7	878	4	176
	PDA	8	166	10	1
	MA	9	0	0	0
Number of cells per spore	OA	10	8.3	10.5	8.3
	PDA	11	7.9 ²⁾	7.6	8.0
	MA	12	NC	NC	NC
Length of spores (µm)	OA	13	70.2	99.3	80.4
	PDA	14	76.1	74.5	75.2
	MA	15	NC	NC	NC
Width of spores (µm)	OA	16	16.6	16.6	16.6
	PDA	17	16.6	16.6	16.6
	MA	18	NC	NC	NC
Spore shape	OA	19	1.7	1.9	1.8
	PDA	20	2.0	2.2	2.5
	MA	21	NC	NC	NC
Max. number of cells per spore	OA	22	13	13	11
	PDA	23	12	10	8
	MA	24	NC	NC	NC
Min. number of cells per spore	OA	25	3	9	4
	PDA	26	5	4	5
	MA	27	NC	NC	NC
Max. spore length (µm)	OA	28	115.9	132.4	115.9
	PDA	29	99.3	99.3	99.3
	MA	30	NC	NC	NC
Min. spore length (µm)	OA	31	33.1	49.7	33.1
	PDA	32	33.1	49.7	33.1
	MA	33	NC	NC	NC

1) OA = oatmeal agar
PDA = potato dextrose agar
MA = malt agar

2) No spores found. Entry could not be completed.

Appendix B. continued

4	5	6	7	8	9	10	11
2	3	1	1	2	3	3	3
4	3	1	2	1	3	3	3
3	3	1	1	1	3	3	3
0	0	0	0	0	0	0	0
0	0	0	0	2	0	0	0
5	0	0	0	0	0	0	0
415	233	9	27	172	6	7	5
3	7	0	11	0	6	5	6
4	1	0	0	0	3	2	0
9.2	8.7	5.6	7.3	10.1	6.2	7.1	7.6
6.0	9.0	NC	7.2	NC	5.7	6.0	7.7
8.0	6.0	NC	NC	NC	9.3	6.5	NC
79.6	78.1	36.7	69.8	102.9	52.5	63.9	69.5
49.7	68.5	NC	82.8	NC	38.6	49.7	55.1
70.2	66.2	NC	NC	NC	88.2	57.9	NC
16.6	16.6	8.3	16.6	16.6	16.6	16.6	16.6
16.6	16.6	NC	16.6	NC	16.6	16.6	16.6
16.6	16.6	NC	NC	NC	16.6	16.6	NC
1.9	1.6	1.4	1.7	2.1	1.9	1.8	1.5
3.3	2.5	NC	2.1	NC	1.6	1.6	2.6
2.4	2.0	NC	NC	NC	2.1	1.1	NC
12	12	6	11	14	9	8	9
8	10	NC	10	NC	6	7	10
10	8	NC	NC	NC	10	8	NC
5	3	5	3	4	4	6	6
3	8	NC	5	NC	5	5	5
6	4	NC	NC	NC	9	5	NC
115.9	115.9	49.7	132.4	198.6	66.2	82.8	82.8
66.2	82.8	NC	132.4	NC	49.7	66.2	66.2
99.3	82.8	NC	NC	NC	99.3	66.2	NC
33.1	33.1	33.1	33.1	33.1	33.1	49.7	66.2
33.1	33.1	NC	49.7	NC	33.1	33.1	33.1
49.7	33.1	NC	NC	NC	82.8	49.7	NC

Appendix B. continued

Properties	Nutrient agar	Variable	Isolate			
			12	13	14	15
Number of growth rings	OA	1	3	3	3	
	PDA	2	3	3	3	
	MA	3	3	3	3	
Number of white patches	OA	4	0	0	0	
	PDA	5	0	0	0	
	MA	6	0	0	0	
Number of spores in 0.9 mm ³	OA	7	12	3	10	
	PDA	8	9	6	7	
	MA	9	3	1	2	
Number of cells per spore	OA	10	7.8	7.3	4.7	
	PDA	11	6.4	7.7	9.6	
	MA	12	8.0	11.0	7.0	
Length of spores (µm)	OA	13	63.4	60.7	35.4	
	PDA	14	96.5	74.5	97.0	
	MA	15	55.1	82.8	57.9	
Width of spores (µm)	OA	16	16.6	16.6	16.6	
	PDA	17	16.6	16.6	16.6	
	MA	18	16.6	16.6	16.6	
Spore shape	OA	19	1.5	1.5	1.8	
	PDA	20	1.7	1.8	1.7	
	MA	21	1.3	4.0	3.8	
Max. number of cells per spore	OA	22	11	8	6	
	PDA	23	10	9	13	
	MA	24	9	11	5	
Min. number of cells per spore	OA	25	5	7	4	
	PDA	26	4	6	5	
	MA	27	6	6	2	
Max. spore length (µm)	OA	28	82.8	82.8	82.8	
	PDA	29	82.8	82.8	115.9	
	MA	30	66.2	99.3	82.8	
Min. spore length (µm)	OA	31	33.1	49.7	16.6	
	PDA	32	49.7	49.7	66.2	
	MA	33	49.7	49.7	33.1	

Appendix B. continued

15	16	17	18	19	20	21	22
3	3	3	3	3	3	2	0
3	3	3	3	3	3	3	0
3	3	3	3	3	3	3	0
0	0	0	0	0	0	0	0
0	0	0	0	0	0	2	0
0	0	0	0	0	0	-1	0
74	98	119	79	92	140	70	34
3	0	7	28	49	20	2	0
35	74	19	6	9	7	0	0
8.4	7.2	7.9	7.7	7.5	7.2	10.1	5.1
6.3	NC	6.0	6.9	6.7	6.6	10.0	NC
7.3	7.1	5.8	6.0	6.8	6.6	NC	NC
54.6	57.3	60.6	54.6	53.0	54.9	95.3	27.8
49.7	NC	56.8	49.7	58.8	51.3	74.5	NC
59.6	60.2	48.8	46.8	58.9	42.5	NC	NC
16.6	16.6	16.6	16.6	16.6	16.6	16.6	8.3
16.6	NC	16.6	16.6	16.6	16.6	16.6	NC
16.6	16.6	16.6	16.6	16.6	16.6	NC	NC
1.8	1.9	1.8	1.6	1.6	1.7	1.8	1.7
2.2	NC	1.7	1.6	1.7	1.7	1.4	NC
1.3	1.6	1.4	1.7	2.2	2.1	NC	NC
11	10	11	11	10	11	15	7
9	NC	7	10	10	10	11	NC
12	11	8	7	9	9	NC	NC
3	5	4	4	3	4	4	3
4	NC	5	5	3	4	9	NC
3	4	3	4	5	3	NC	NC
82.8	99.3	115.9	82.8	82.8	82.8	215.2	33.1
66.2	NC	66.2	82.8	99.3	66.2	82.8	NC
82.8	82.8	82.8	66.2	66.2	66.2	NC	NC
33.1	33.1	33.1	33.1	33.1	33.1	33.1	16.6
33.1	NC	49.7	33.1	33.1	33.1	66.2	NC
33.1	33.1	33.1	33.1	49.7	33.1	NC	NC

Appendix D. Characteristics of groups of isolates of *Drechslera* spp. used in numerical analysis.

Properties	Nutrient agar	Subgroup			Group	
		1	2	3	1) ¹⁾	2
number of growth rings	OA ²⁾	3.0	2.8	3.0	2.9	1.3
	PDA	3.0	3.2	3.0	3.1	1.1
	MA	3.0	3.0	3.0	3.0	1.0
number of white patches	OA	0	0	0	0	0
	PDA	0	0	0.2	0.1	0.6
	MA	0	0.8	0	0.3	0.1
number of spores on 0.9 mm ³	OA	5.3	154.2	104.6	88.0	170.1
	PDA	5.8	10.2	14.6	10.2	27.0
	MA	1.5	24.2	3.0	9.6	0
number of cells per spore	OA	7.1	7.9	7.4	7.5	8.1
	PDA	6.8	6.4	7.9	7.0	8.2
	MA	8.9	6.8	7.0	7.6	-
length of spores (µm)	OA	61.7	60.3	62.1	61.4	71.7
	PDA	54.5	51.4	79.2	61.7	77.0
	MA	76.3	54.7	59.5	63.5	-
width of spores (µm)	OA	16.6	16.6	16.6	16.6	14.2
	PDA	16.6	16.6	16.6	16.6	16.6
	MA	16.6	16.6	16.6	16.6	-
spore shape	OA	1.7	1.8	1.7	1.7	1.8
	PDA	1.9	2.1	2.0	2.0	1.1
	MA	2.4	1.8	2.3	2.2	-
max. number of cells per spore	OA	8.5	11.0	10.0	9.8	11.3
	PDA	8.0	8.8	10.2	9.0	10.8
	MA	9.7	9.5	7.8	9.0	-
min. number of cells per spore	OA	5.8	4.2	3.8	4.6	4.4
	PDA	5.3	4.2	5.0	4.8	5.8
	MA	6.7	3.8	4.3	4.9	-
max. spore length (µm)	OA	78.7	96.6	96.0	90.4	125.3
	PDA	66.2	69.5	96.0	77.2	103.5
	MA	88.3	80.0	74.5	80.9	-
min. spore length (µm)	OA	49.7	33.1	29.8	37.5	33.1
	PDA	37.3	36.4	43.0	38.9	49.7
	MA	60.7	35.9	41.4	46.0	-

1) Group 1 is the average value of subgroups 1, 2, and 3.

2) OA = oatmeal agar
PDA = potato dextrose agar
MA = malt agar