

DEVELOPMENT OF CRITERIA AND METHODS FOR IMPROVING THE
EFFICIENCY OF SOIL MANAGEMENT AND TILLAGE OPERATIONS,
WITH SPECIAL REFERENCE TO ARID AND SEMIARID REGIONS

II. REPORT ON THE OBSERVATIONS OF THE ACTIVITIES OF A LOCAL
FARMER NEAR NIONO, MALI, SUMMER 1979.

W.B. HOOGMOED and D.T.I. KIEVIT

Report 1981, nr. 2.

lh

GRONDBEWERKING

האוניברסיטה העברית בירושלים
THE HEBREW UNIVERSITY OF JERUSALEM



ISRIC LIBRARY

ML 1981.04

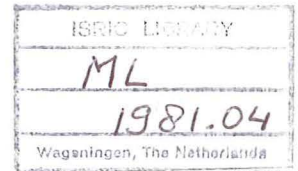

DEVELOPMENT OF CRITERIA AND METHODS FOR IMPROVING THE EFFICIENCY
OF SOIL MANAGEMENT AND TILLAGE OPERATIONS WITH SPECIAL REFERENCE
TO ARID AND SEMI-ARID REGIONS.

II. Report on the observations of the activities of a local farmer
near Niono, Mali, summer 1979.

W.B. Hoogmoed and D.T.I. Kievit

Tillage Laboratory, Agricultural University, Wageningen, The Netherlands.

February 1981.

Scanned from original by ISRIC - World Soil Information, as ICSU World Data Centre for Soils. The purpose is to make a safe depository for endangered documents and to make the accrued information available for consultation, following Fair Use Guidelines. Every effort is taken to respect Copyright of the materials within the archives where the identification of the Copyright holder is clear and, where feasible, to contact the originators. For questions please contact soil.isric@wur.nl indicating the item reference number concerned.

CONTENTS

	page:
1. <u>INTRODUCTION</u>	1
2. <u>REVIEW OF LITERATURE</u>	2
- Geography	2
- Climatology	2
- Soils	2
- Farming operations	3
- Crops and cropping methods	4
- Soil management	7
- Tillage	8
3. <u>THE CASE STUDY</u>	10
- Location	10
- General information on the farm and farming activities	10
- Dry matter production - yields	19
- Moisture	20
- Tied ridging	21
- Effect of superficial tillage on ridges	23
- Effect of tillage system and rainfall on ridge shape	24
4. <u>CONCLUSIONS</u>	26
5. <u>LITERATURE</u>	29
ANNEX: Figures 1 - 16	32

1. INTRODUCTION

In the project "Development of criteria and methods for improving the efficiency of soil management and tillage operations, with special reference to arid and semi-arid regions", research was carried out in Mali, West-Africa in 1978 and 1979. Part of this work has already been reported by Hoogmoed (1978, 1980). The work reported here was part of the activities during the wet season of 1979. As explained in the first report over 1979 (Hoogmoed, 1980), one of the aims of the research was to gain experience and knowledge on physical soil processes that determine many practical problems for the local farmers, i.e. the phenomena of poor and inefficient use of the available rainwater because of surface sealing and crusting and subsequent runoff. An other practical problem is the extreme hardening of the sandy soils during the dry season.

Since it is always the farmer who has to cope with these problems, it is very important to have a clear picture of the activities of the farmer, to know how and if possible why he manages his farm in a certain way.

With this objective, the activities of a local farmer in the Niono area of Mali have been followed during the rainy season of 1979. Besides observations on the farmers' activities, rainfall was measured and some introductory experiments were carried out to investigate the effect of some (simple) water conservation methods. Most of the observations were taken and reported (in Dutch) by Kievit (1980), as part of his M.Sc. study. Chapter 2 of this report gives a brief review of literature relevant to farming in the West African region. Chapter 3 describes the actual observations and experiments on the farm.

2. REVIEW OF LITERATURE

Geography.

General (geographical) studies on the semi-arid area of West Africa have been undertaken by Harrison Church (1970) and Morgan and Pugh (1969). In these studies, besides the social, economical and political situation, agriculture in the area is discussed as well, although the treatment is only of a general nature.

Climatology.

A detailed study on the (agro)climatology of the area south of the Sahara was made by Cocheme and Franquin (1967) for the World Meteorological Organization. A regional technical conference on the same topic was held later in Dakar, Senegal (WMO, 1971) and an evaluation of the climate and water resources was made by Davy, Mattei and Solomon (1976).

In this study, climatological data were collected and analysed with the purpose of assessing possibilities and potentialities of agricultural production per region. Growing season is not longer than 90 days, regardless of soil characteristics. Suitable crops are sorghum, millet, niébé and groundnuts. For the most important crop millet, the danger of crop failure is estimated to be in 20% of years. Recommended varieties of the crops mentioned should have a growing period of 90-100 days.

Soils.

Basic information on soils of the area may be found in Ahn (1970) and Jones and Wild (1975). These books also contain extended bibliographies on soils with special reference to West African conditions. More detailed information on the area around Niono is given by Stroosnijder (1977). Charreau and Nicou (1971) and Charreau (1977) have summarized the most important soils in West Africa, especially with respect to their characteristics relevant to the management and tillage of the soil.

Seven broad groups or soil units are recognized:

1. Modal brown and reddish brown subarid soils (Camborthids) between 200 and 500 mm isohyets.
2. Slightly leached gray ferruginous soils (Ustrophepts); ancient eolian deposits (500 - 900 mm).
3. Grey ferruginous leached soils (Ustalfs); most common in the area, often with strongly differentiated profiles.
4. Impoverished slightly desaturated ferralitic soils (Alfic Eustrustox);

not extensive in area except in southern Senegal.

5. Vertisols.
6. Mineral hydromorphic soils; widespread in the area, constituting the major parts of the alluvial plains of the main rivers, important for irrigated and (temporarily) flooded fields.
7. Iron pans: a large area between 500 and 900 mm, very low agronomic value because of very thin soils.

The soils mainly under dryland or rainfed farming in West Africa are the subarid and ferruginous soils, which are usually low in clay content (< 20%). The upper horizons of these soils are generally "coarse loamy", with as clay mineral in the ferruginous soils kaolinite (non-swelling or -shrinking) and in the subarid soils montmorillonite, but only in very small percentages (1-10%).

This implies, that generally these soils have:

- a very weak or no structure
- a rather low total porosity (often less than 40%)
- a very low percentage of pores that can be used by roots ("structural porosity")
- strong tendency to compaction and hardening during the dry season
- often a fairly high infiltration capacity, which is however limited by the formation of superficial crusts
- small water holding capacity
- low susceptibility to erosion

Farming operations

In dryland farming the crop management systems may be grouped into two categories: subsistence cropping and commercial crop production (Isom and Worker, 1979). In subsistence farming, the farm provides the farmer and his family with the needs for foods and possible other materials for their living. In a commercial crop production system, crops are grown for sale and not for consumption by the farmer. In the subsistence system, no money will be involved and thus the supplies available on the market cannot be used by the farmer to improve his situation. The commercial crop producer on the other hand, may be able to use capital for fertilizer, seeds, machinery to increase the input and possibly to increase yields per hectare.

Of course, cases of "pure" subsistence farming do hardly exist, in most cases some excess of products may be produced, which can be sold or exchanged for other products (or services).

In the West African Sahel and (northern) Savanna region, the crop management system is a combination of both subsistence and commercial crop production; millet and sorghum is grown as a staple food crop and groundnuts as a cash crop. In areas where the moisture situation permits, maize and cotton are grown as well. With respect to the cultural system of the crop production, there is a variation in systems from permanent cultivation (annual cropping) to shifting cultivation, with a large number of intermediate systems (fallow systems, ley farming etc.) (Isom and Worker, 1979, Ruthenberg, 1974). In the Sahel-Savanna zone, generally one of these intermediate systems is used. It will depend on factors like population pressure, soil type etc., which pattern exactly will be used.

A "pure" shifting cultivation system in a semi-arid climate is described by Kassas (1970); a period of 4 to 10 years of cropping is alternated with a period of 20 - 25 years of recovery, during which period gum-arabic may be "harvested" from *Acacia* species. The alternate crop-fallow system (with or without pasture) as described by Doolette (1977), Oram (1977) and Booster and Bolton (1977) seems to be favourable only in semi-arid regions with winter rainfall.

Crops and cropping methods

Crops.

Detailed accounts on crops of the West African savanna are given by Kassam (1976) and Irvine (1976). As mentioned before, the major crops in the area are sorghum (*Sorghum bicolor*) and millet (*Pennisetum typhoides*) as cereals and legumes like cowpea (*Vigna sinensis*) and groundnuts (*Arachis hypogea*). In West-Africa many local cultivars will be found, usually all adapted to specific conditions. Sorghum, grown primarily for grain for human consumption reaches its greatest concentration in terms of production in areas where rainfall varies from 600 - 1000 mm. A very important feature of the local sorghum is, that the date of heading is closely related to the average date of the end of the rains and thus the seeds are set in a comparatively dry period, avoiding severe attacks by moulds or insects. Growth cycles range

from 120 - 135 days in the north to even more than 240 days in the south. Length of the plant may be from 3 - 6 m (depending on the growth cycle length).

Because of photosensitivity, date of sowing has a marked effect on yields of the sorghum crop. When heading is late (late sowing, early end of rains), grains may not fill completely. It is quoted by Kassam (1976), that each week delay in sowing resulted in a delay of approx. 2 days of heading. This delay caused a decline in yield of approx. 10 - 15% of maximum yield (so per week of later sowing).

Some economically important diseases of sorghum are smut, downy mildew and charcoal rot. Birds (*Quelea* spp.) also may pose an important problem. Weed problems may be caused by *Striga* spp.

Millet, as sorghum grown primarily for human consumption, can be grown in regions too dry for sorghums, but it is also important in the typical savanna zones. Two types of millet may be distinguished: Gero-millet, a short-season, non photoperiodic type, and Maiwa millet, a long season photoperiodic type. The Gero type however, accounts for approx. 80% of the total area under millet. The growing cycle of Gero millets is 75 - 100 days, Maiwa takes 120 - 280 days, where (as with sorghum), Maiwa millets usually are adapted to flower near the end of the rainy season. Length of Gero millet may vary between 1.5 and 3 m; Maiwa is taller, 3 - 6 m. Gero millet is higher yielding than Maiwa and produces this yield also more quickly. Maiwa millet is preferred over sorghum on light soils.

Since Gero millet matures in a relatively short period and will be sown early, the crop is ripe in a wet period. There are only minor problems with pests or diseases. Millet is reported to be well adapted to conditions of lighter soils, high radiation and temperature. The crop may (once established) have a marked degree of drought resistance, but it cannot survive waterlogged soil conditions. A downy mildew type (green ear) is the most important disease, pest damages to millet is minimal, but bird damage (*Quelea*) is a major problem. *Striga* weed attacks millet, but to a lesser degree as sorghum.

Cowpea, the major grain legume crop serves as a food and a cash crop. The plant is either short-day or day neutral. Although both (night) temperatures and daylength are important in flowering and vegetative growth, these factors offset each other. The crop is grown under a wide range of soil and climatic conditions in the Savanna areas. It prefers well drained soils.

Cultivars vary in maturity between 80 and 160 days or more, local varieties often have a spreading and indeterminate growth habit and mature late, whereas improved varieties have an erect and determinate growth habit. Although intercropping with sorghum or millet will reduce yields drastically, there is hardly any sole cropping of cowpeas. Local varieties are more adapted to lower light intensities than improved ones.

Pest- and disease problems in cowpea are less in the northern areas (lower rainfall) in general however, a large number of bacterial and viral diseases exist and may, together with pest problems, cause large losses of yield.

Groundnut is the major cash crop in the West African Savanna, but it is also an important part of the diet of the local population. Crop residue is used as cattle feed. Two broad groups of groundnut cultivars are grown in W-Africa; the alternately branched cultivars (Virginia and Castle Cary group) and the sequentially branched cultivars (Spanish and Valencia group). Crop growth cycle is between 120 and 145 days and 50 - 115 days respectively. A groundnut crop is easier to produce in the drier zones north because of a lesser incidence of pests and diseases. It is important that the crop is mature at the end of the rains; when rains cease too early, water stress during pod filling may reduce yields considerably, whereas a wet harvest gives problems of aflatoxin production.

Although the majority of the area of groundnuts is with some kind of intercropping, approx. 15% is grown as a sole crop in the northern savanna region of Nigeria, and a very large percentage is as a sole crop in Senegal.

A large number of disease and pests is reported to pose problems, during growth as well as during harvest and storage. Moist conditions are favourable to these attacks.

Cropping methods.

Cropping methods are closely related to local conditions and cultural practices.

Four major systems may be distinguished here:

- Sole cropping, where only one crop is grown (at any time) in one field,
- Mixed cropping, which can be defined as the system where two or more crops are grown simultaneously with no row arrangement,
- Intercropping, where again two or more crops may be grown, but in a definite pattern,

- Relay cropping: successive crops are grown in the same field in one season.

Sole cropping is a system which will mainly be used for commercial crop production, the possibilities for mechanization and specific maintenance operations are greater. There is however a danger for diseases to destroy the whole crop in one time, so the risk factor is also greater. In areas where mechanization is not highly developed, mixed cropping will be found; this applies also to the zone of our attention, as well as the major part of the agricultural area in Mali, even with a common use of animal drawn equipment. As major advantages may be mentioned in this system (which usually includes the combination of millet and a legume):

- often greater overall crop returns,
- better weed control and a reduced erosion risk because of a better soil cover,
- soil fertility may be improved by the N-fixing activity of the legumes,
- failure of one crop does not imply a total failure.

The disadvantages however show, that mixed cropping does not allow easy improvements in the system:

- requires manual labour, management takes more time per unit area,
- pesticides cannot be applied easily,
- because of many variables, improvement of only one factor may have many (unexpected) negative effects.

Some of the important disadvantages may be eliminated in the system of intercropping; mechanization is possible, as well as improved crop management practices. Relay cropping could be regarded as a special form of mixed- or intercropping, where one crop will be harvested before the end of the growing period of the (often undersown) crop. E.g. a cowpea crop may be sown under a quick growing millet or on the other hand, an early crop of cowpea may precede a millet or sorghum.

Soil management

The cultivation methods are closely correlated with traditions and habits of the different tribes or population groups, but also with the level of development or mechanization. The lowest level of land management is by using the hoe in manual labour; this system is still widely used in many parts of West Africa (Charreau, 1977).

Soil preparation in this case is very superficial. With the use of hoes,

generally a kind of mound culture is practiced (Isom and Worker, 1979). The soil is scraped into mounds of varying shapes and dimensions, ranging from 30 to more than 50 cm high. The reasons for mounding are mainly: a. deepen the soil available for the plant roots where the natural soils are too shallow, b. provide drainage for crops that cannot stand or react negatively in wet soil conditions, c. collecting the organic matter available on the soil surface from the previous cropping period (crop and weed residue, manure) and incorporating this in the mound to be constructed.

In this way, fertility may (partly) be maintained. (Inter)cropping takes place by planting the crops at various locations on or between the mounds. Ridge culture may be regarded as a variation of mound culture and is also the next step associated with the use of animal drawn equipment. Ridges may still be constructed manually (Buntjer, 1971), but very often this operation is carried out with animal drawn tools.

A crop culture on the flat is not common, although it is seen e.g. around the villages, where an intensive cropping pattern may be found, using household refuse and litter for keeping a high fertility level of the fields close to the village, used for either garden crops or early millets.

Animal drawn equipment is still not common for West-Africa, animal traction is mainly used for completing planting and weeding operations and in certain areas like Senegal and Mali, for soil preparation.

The use of tractors or motorised equipment is not relevant here, since this level of mechanization is found only rarely in certain cash crop areas developed by the governments often with foreign financial aid (irrigation schemes etc.).

Tillage.

The effects of tillage operations are seldom very clear and usually of a complex nature; since tillage changes the soil physical condition of the soil (including hydraulic properties), there will be a multiple effect on plant growth. E.g. when crop yields are higher under a certain tillage system, this is an indirect effect of tillage and a direct effect of differences in water and nutrient availability, mechanical resistance, temperature, etc., which are all induced by the tillage operations. Before further discussing tillage effects on soil and crop, the objectives of soil management will be stated.

In general, the aims of tillage are:

- improving the soil structure, to optimize the environment of the seed to germinate and emerge and of the roots to maximize the water and nutrient supply.
- control of weeds.
- incorporate organic matter or other desired materials in the soil.

For the West-African semi-arid conditions, the optimization of the water supply and weed control are the major objectives. The soil management system should on the long run minimize the erosion and maintain or improve the soil fertility and structure.

In view of the characteristics of the most common soils in the savanna, soil tillage will have a distinct (but short-term) effect on the physical condition of the soil. In semi-arid agriculture with low mechanization levels, two types of tillage could be distinguished:

- a. the main tillage operation, possibly involving ploughing, chiseling (animal traction) or deep hoeing (manual labour) which is applied before sowing of the crop.
- b. the superficial tillage operations, carried out either at the beginning of the growing season (seedbed preparation) or during the crop season as weed control operation.

As is found in many studies in semi-arid regions, the emergence and establishment of a proper plant stand is of extreme importance, so tillage should be the tool to create the optimum environment for the germinating and emerging seed given the soil and climatic conditions.

Ploughing and deep chiselling will give a reduction of bulk density, thus improving the rooting possibilities of the plant. This loosening effect however may last only for some weeks on unprotected, unstable soils (like the sandy-loamy soils), especially under severe rainfall; Because this period is in the important stage of the development of the plant, the short term nature of this effect is less serious.

Improvement of plant growth by tillage here will be a combined effect of better rooting possibilities and usually a better moisture supply because the infiltration capacity of the soil will be increased considerably. The "moisture supply effect" will in many cases be even more important than the "loosening" effect (Rawitz, Hoogmoed and Morin, 1980).

The superficial tillage operations also will have - besides the weed control effect - an important effect on moisture supply, specifically on crust forming soils.

3. THE CASE STUDY

Location.

The farm which was subject to the study is located near the town of Niono, in Mali at a latitude of $14^{\circ}35'$ N. (See fig. 1). This is the southern part of the climatological and ecological zone called the "Sahel".

Average rainfall in the Niono area is between 400 and 600 mm. The native vegetation is at the transition of the Sahel to the Savanna type; approx. 30% of the vegetative cover is by trees. Some climatic data of the 500-700 mm rainfall region are given in fig. 2.

General information on the farm.

The farmer.

The farmer on whose farm the observations have been made, is of the Bambara tribe, a tribe of farmers, counting for a large percentage of the Mali population. This farmer cannot be regarded as an "average" farmer as common for the area; during the survey, his main job was driver in a Dutch research project in Niono. The size of the family, viz. the number of people to be fed by the farmers' enterprise, was in 1979 26 persons. Because of his own job as driver, the daily activities at the farm were led by a younger brother and a permanent labourer.

Lay-out of the farm field.

The farmer had in 1979 the possession of approx. 39 ha. Of this area, approx. 33 ha was due to be planted with millet and the remaining area with groundnuts. A size of farm of 39 ha may be considered "large" for the region, although no official information on farm size could be obtained. As a rough estimate, the average farm size will be between 5 and 10 ha. In 1978 the farmer cultivated only 15 ha. but for 1979 an additional area was allocated to him by the local authorities. In addition to the 39 ha of "dryland" area, the farmer also cultivated a field in the irrigation scheme of the "Office du Niger" near Niono. The dryland area, approx. 10 km south east of Niono is in one block. A map of the field, including some contourlines, is given in fig. 3.

In general, the slopes in the field did not exceed 1.5%. The field at the time of soil preparation was not bare, scattered over the area there were trees and patches of shrub. Approx. 75% of the total area could be cultivated by the farmer.

Soil.

Some physical characteristics of the soil have been measured: a partical size analysis and some other data are given in table 1.

Table 1. Particle size analysis and other soil data.

fraction (μm)	(%)		
<2	5.0	pH (KCl)	4.7
2 - 4	0.3	org. matter	0.5 %
4 - 8	0.3	CaCO ₃	0.1 %
8 - 16	2.0	Fe ₂ O ₃	0.77%
16 - 25	0.3		
25 - 35	0.5		
35 - 50	9.6		
50 - 75	17.6		
75 - 105	17.8		
105 - 150	14.8		
150 - 210	11.0		
210 - 300	7.5		
300 - 420	6.8		
420 - 600	4.6		
600 - 850	1.7		
850 - 1200	0.2		

The ψ - θ and K- θ relations were determined in the laboratory, by means of suction tables and the hot-air method as described by Arya (1975) for the determination of K vs. θ . The respective curves are given in fig. 4. The soil is typical for the region, a very fine sandy soil, with a tendency to become very hard when dry (as also described by Charreau, 1977).

Bulk densities of the soil were determined using core samples. These values together with pore volumina are given in table 2.

Table 2. Bulk density and pore volume on different depths.

depth	5 cm		15 cm		25 cm		ρ_d : g/cm ³
	ρ_d	P.V.	ρ_d	P.V.	ρ_d	P.V.	
A	1.64	39.1	1.51	43.2	1.44	45.9	
	1.65	38.0	1.61	39.5	1.47	44.7	
B	1.67	37.2	1.52	42.9	1.45	45.5	P.V.: %
	1.65	38.0	1.53	42.5	1.44	45.9	

Penetrometer values were measured with a pocket penetrometer at 4 locations, measured horizontally over 5 cm depth increments. In fig. 5 the results are given, together with the moisture content at the depth and time of measurement.

Farming equipment.

The equipment available to the farmer (as owner) consisted of three plows for animal traction. Two of these plows were equipped with a normal mouldboard (no coulters or other attachments) and one plow had a ridgeformer ("middle-buster"). The plows are supported in front by a landwheel. Each plow is pulled by a pair of bullocks (Zebu) by means of a double neckyoke and a chain. Besides the plows only hand-held hoes, with short and long wooden handles and an iron blade were used. No other implements were present. For transport between the field and the village or market, a two-wheeled cart (rubber pneumatic tyres) pulled by a donkey was used.

The farmers' activities.

Since the soil is too hard to be tilled by animal traction in a dry condition, the farmer is forced to wait until the soil is softened by the (rain)water. The decision to start the operations is based for a great deal on the amount of rainfall that falls in the beginning of the rainy season, but also on the probabilities and expectations for a more stable and reliable rainfall pattern. The latter is of course based on the farmers' experience; although in 1979 there was approx. 50 mm of rain by the end of June (see fig. 6), this was no reason for the farmer to start his activities. In the region however, some sowing was practiced in June with the millet type "actif" (or Gero millet, Kassam 1976). This is a millet with a growing period of only two months, compared to the "tardif" (or Maiwa) millet with a growing period of approx. 5 months.

"Actif" millet is grown in the direct vicinity of the villages right after the start of the rains, usually in a flat and fairly deep seedbed (till 10 cm depth). Occasionally household refuse is applied as manure. Use of two types of millet is clearly a spreading of risks, in case of emergencies after the dry season, "actif" millet may quickly produce food.

Soil preparation

In 1979 the farmer started preparing a seedbed on July 16th (as compared with July 5th in 1978). Sixteen mm of rain on July 15th was considered to be sufficient to give a reasonable start. The first activities were on a part of the field which was also cultivated in the previous years. On this part, the ridge pattern could still be distinguished. Moisture content was 4.3% in the (old) furrows and 2.9% on top of the ridges (percentage by weight, measured over the top 10 cm). After 3 days however, the moisture content of the soil was too low again, and the draft requirements were too high for the animals, especially for the bullockteam with the ridger. It was decided to move the activities to a lower area in the field (the "bas-fond") where moisture content was still higher. On the fifth day, moisture content on this spot was also too low and the activities were interrupted. After 8.5 mm of rain on July 22nd, the activities could be continued and no problems concerning moisture for tillage were encountered since then.

In 1978, approx. 15 ha of the field had been under a (millet)crop. Since no tillage took place after harvest, the original ridge pattern was still visible. On the newly aquired land, the surface was still virgin, flat with a grassy vegetation. The system of tillage for both parts of the fields was basically the same, but because of the initial condition of the soil surface, the tillage operations were different. On the previously tilled land, the position of the ridges was not changed and the ridges were reshaped by plowing out the old furrows. This was done with the mouldboard plow by going twice through the same furrow, the second time in opposite direction, thus transporting the soil from the furrow onto the ridge. The pair of bullocks is attached to the plow in such a way, that one bullock walks in the furrow to be opened or just opened. The plow is virtually in balance in the first pass, in the second pass however, there is no soil supporting the landside to counterbalance the side thrust. The plow had to be kept tilted sideways to keep a straight line. With the ridger, the reshaping of the ridges was carried out in one pass per furrow, resulting in a better quality work (no

balancing problems).

On the virgin part of the field, the quality of the work with the mouldboard plow was better, since here an inverting action of the soil was necessary because of the vegetation. The problem with balancing in the second pass was also less. The ridger did a poor job here because soil could not be transported and inverted far enough to create a reasonably sized ridge. Superficial roots of shrubs in this part of the field posed more problems for the ridger, since the cutting action of the share on the ridger was less than the share on the mouldboard plow.

Each pair of animals with a plow or ridger was led by an older person steering the plow and a young boy guiding the animals in front (by walking ahead) in order to have one of the animals following the furrow. Two pairs of bullocks consisted of one older well-trained animal and a young one, who had to be trained during the tillage activities. The third pair, to do the harder work with the ridger, consisted of two older, trained bullocks.

It must be mentioned, that compared to tillage work on other farms in the region, the operators certainly did not do a very good job!

The distance between the ridges made was on the average 80 cm, but this value was ranging between 60 and 100 cm, due to the system of tillage and the relatively low skilled operators.

To measure the effect of the tillage operations in terms of soil transport and soil surface configuration, reliefmeter measurements were taken using a simple (wooden) reliefmeter (Kouwenhoven, 1979). This was done at two randomly chosen spots in the field at three dates: before and immediately after tillage and 15 days after tillage, during which period there were two rainfall events of 10 and 38 mm. The crosssection over 4 m of the surface is given in fig. 7. The original ridge pattern is still visible in this figure, the new ridges being made on top of the old ones, giving a ridge height of 20 - 25 cm. The ridges measured were constructed with the mouldboard plow, which explains the irregular and asymmetric shape on top of some of the new ridges. The line depicting the relief after 15 days, so after two rainstorms shows both the consolidation of the tilled layer and the fact that soil was washed away from the top of the ridges, causing the roots of the plants to be exposed, increasing the risk for the plant to fall.

Sowing.

Sowing of the millet is done by hand. Seeds are carried in a cup made of a

calebash. The sower takes a number of the small seeds (approx. 15) between thumb and fingers and drops this handful (while standing up) on top of the freshly plowed ridges, so without making a planthole. With his foot the seeds are now covered and pressed into the soil, to get a better seed-soil contact and thus a better moisture supply to the seed. Sowing depth is not more than 1 - 2 cm. The millet seeds were mixed with niébé beans (*Vigna unguiculata*), in this case to provide feed for the animals of the farmer after the harvest of the millet. The ratio millet - niébé seeds was such, that in the final stand approx. one out of nine "clusters" of millet plants was also containing a niébé plant (creeping type). Planting distance was approx. 1.10 m (two small steps of the sower).

Emergence of the plants.

Emergence of the first sown seeds was poor because of the low moisture content of the soil (approx. 4%). An area of almost 4 ha was replowed and sown again for this reason. On August 8 plants were counted on the area sown before July 26. Plant stand was counted at 40 strips of each 11 m along randomly chosen ridges.

Assuming a planting distance of 1.10 m, 400 "clusters" should have been sown; 252 clusters (with a minimum of one plant) were counted, giving an emergence percentage of 63%.

On August 22 plants were counted on an area planted between July 26 and August 15; emergence percentage here was 6%, in a lower spot (more moisture) even 89%. These figures are still fairly low, since 15 seeds per cluster were sown, and even one plant per cluster was counted. Germination of the seeds was determined in the laboratory as 70%.

It was observed that emergence in the depressions was not maximal because of excess water, causing germinated plants to die.

Time studies of the tillage and sowing activities.

The activities in the field during tillage and sowing were such, that it is not possible to present a fixed pattern of the daily or weekly activities. Before the start of the work in the field, the farmer had drawn the following general scheme for the field activities:

- start of the tillage operations at 7.00 am, continuing with only one break for a meal until 1.00 pm.
- at that time, the bullocks would have finished their jobs for the day and

would be allowed to rest.

- the labourers would now sow the area which was prepared in the morning.
- the day's work would be finished around 3.00 pm.

In practice however, this scheme was hardly followed, although indeed the area prepared was always sown the same day, but sowing (by one of the labourers) often took place in a period that the bullocks had to rest (short breaks in the morning period). Sowing was considered to be less tiring and was done alternatively by the workers.

The tillage and sowing activities were finished on August 15th, one month after the start of the activities. The date of ending the activities is mainly governed by the photoperiodicity of the millet; all "tardif" millet will mature at approx. the same date, irrespective of planting date, so the late planted crop would have only a short growing season. Planting later than August 15 would not be economical with this type of millet, yields would be very low.

Although because of the irregular schemes no exact measurements could be made, the following approximation is shown in table 3. Assuming a working day of 7.5 hours and a distance between ridges of 80 cm, working speed and labour output were measured.

Table 3. Labour output and speed of travel during tillage operations.

	"virgin" area		area tilled in 1978	
	labour output (ha/day)	speed (km/hr)	labour output (ha/day)	speed (km/hr)
Ridger	0.35	0.88	0.74	1.16
Mouldboard	0.35	1.09	0.41	1.28

The tillage operation was obviously easier on the previously cultivated area, the animals were able to pull the plow and ridger at a higher speed than in the "virgin" area. Especially the ridging unit did not perform satisfactorily in the virgin area; because of the problems mentioned earlier, working depth was harder to maintain, which was also affecting the speed.

Soil and crop maintenance during the growing season.

The tillage and planting operations were apparently the activities regarded

by the farmer as the most important ones, when compared to the attention that was paid to the maintenance of the crop. Possibly one of the reasons for this attitude was the fact that this farmer was also cultivating an area of approx. 10 ha with rice in the irrigation scheme. There is no application of fertilizer in the dryland crops in the area. Fertilizer is scarce and extremely expensive because of transport costs. A small indicative experiment carried out at the farmer's field (by a project member) showed in 1978 an increase of 40% of millet yield by applying 50 kg N and 50 kg P per ha.

Assuming a price of millet of FM 40,- per kg and a yield of 500 kg/ha, this would be an increase of FM 8000,- per ha (or 20 US \$). This would hardly pay for the cost of the fertilizer, not including even the extra risk (capital investment) and labour involved.

Care of the milletfield was taken by the eldest labourer, who lived in a small village close to the field. Besides the maintenance activities, the man also acted as a guard to protect the field from damage by cattle and monkeys. Although it was announced by the farmer, that groundnuts were going to be planted as well, this plan was cancelled without any obvious reason.

Resowing.

The day following the end of the sowing activities, the field was inspected and on those places where plants had a very poor stand or had not emerged at all, a resowing took place. This was done by using the long-handled hoe, making plantholes going crossway over 5 ridges at a time. By doing so, the square planting pattern (as common in the region) was maintained. The digging of the plantholes with the hoe seemed to be mainly to break up the crust formed on top of the ridges, in order to create a better moisture supply to the seed.

Weed control or crustbreaking?

Approx. 3 days after the end of the soil preparation and sowing, the resowing operations were also finished and weeding was started. This activity was carried out again with the plow. As the farmer explained, this operation was a combined action to control weeds and to earthen up the ridges. The ridger however, was not used because of an unsatisfactory cutting action

and a poor job in terms of ridgeshaping. This was again the farmer's motivation, since with the present vegetation of small grasses, a covering with soil by the ridger should have given reasonable results for suppressing the weeds.

Weeding with the plow was now carried out in approx. the same manner as the primary tillage operation; one furrow was tilled twice, in the first pass a side of the ridge was cut by the plow and the soil was thrown to the other side. In the second pass, the same happened to the other ridge wall. The final result was effective in terms of weed control, but now the ridges were made with one steep and one gentle slope. After a heavy rainstorm, the soil from the steep slope was washed down in the furrow, exposing the roots of the millet plants. The operator also had to steer the plow very careful, in order not to cut the roots of the plants with the share.

Labour requirement for weeding with the plow was 0.50 ha per plow per day (a team of two people). Comparing the figure with the primary tillage requirements (see table 3), weeding was carried out faster, indicating a lower soil resistance. The weeding activities were restricted to the 3 - 4 leave stage of the weedplants. The area covered by the end of the operations was approx. 8 ha. This approach however is not common (generally the entire area of the farm is weeded at least once), but in this case labour and equipment was needed in the paddyfields of the farmer.

The weeding activities with the plow also will - apart from the weed control effect - have an effect on the infiltration capacity of the soil, since the surface seal, developed under rain will be broken. There is a strong impression, that repeated weeding (either by plows or manually with a hoe) is not only for weed control, but also for the improvement of infiltration of rainwater. In many cases, it could be observed that weeding operations were carried out also in fields with a small weed population.

It is interesting to note that the private field of the permanent labourer and guard, adjacent to the farmer's field, was in a better and cleaner condition, because of more careful attention.

For weed control, no chemical herbicides were used in the area.

Insects and pests.

Control of insects and pests was only preventive, by treating the seeds with an insecticide before sowing. A major problem in the area is that seeds are taken away and eaten by ants. Unfortunately, the composition of

the insecticide could not be recovered, since it was bought on a local market. Any other (specific) insecticides (apart from DDT) are not available in the region.

No other crop production measures were taken during the growing season; in areas with higher rainfall (over 600 mm) usually measures have to be taken. Damage was observed mainly by grasshoppers, though not excessive, this in contrast to crops grown near the irrigation scheme.

Dry matter production - yields.

Dry matter production was measured at November 10 (final yield). Per plot of measurement, ten ridges over a distance of 10 m were harvested, ridge distance and number of plants was determined. Dry matter yield (both grains and total aerial production) was determined by sun-drying the material after cutting and weighing. The plant stand was expressed as a percentage of the maximum possible (assuming the distance between plants at sowing to be 1.10 m).

The results are given in table 4.

Table 4. Dry matter yield of crop at harvesting time (Nov. 10th).

Plot.	Grain yield (kg/ha)	Total d.m. (kg/ha)	Number of plants (% of maximum possible)
1	435	1630	78
2	258	1000	79
3	286	1070	78
Average	326	1233	78

The yield measured appears to be average for the given climatic conditions (compared to figures given in Kassam, 1976 and Irvine, 1976). The development of the crop was followed by dry matter determination on three dates between sowing and final harvest.

Measurements were done at the same locations as for the final harvest, using the same techniques.

Table 5 gives the results of dry matter production on three intermediate dates. On the same observations, root development was tried to be followed, by digging out the roots, washing and drying the material for 24 hours in

an oven at 70° C. Root weights are also given in table 5.

Table 5. Dry matter production of aerial parts and roots at selected data.

Aerial material (kg/ha)				
Plot	17/8	29/8	15/9	10/11
1	3.6	50.5	2341	1630
2	2.3	27.1	1484	1000
3	2.1	60.5	1629	1070

Roots (kg/ha)			
	17/8	29/8	15/9
1	0.9	5.6	71.0
2	0.7	4.0	67.7
3	0.5	4.5	51.0

In particular the results of the root weight determination should be considered only as an indication; probably not 100% of the roots were collected during the sampling, especially in a later phase, where often shallow rooting plants, with wide extending roots were found.

The ratio between weight of aerial parts/roots is high, e.g. for 15/9 this is 33.0 - 21.9 - 31.7 for plot 1,2 and 3 respectively. Assuming the same root weight at November 10, the ratio would have been 23.0 - 14.8 - 21.0 respectively.

Moisture.

On some relevant spots, moisture content of the soil profile during the cropping season was measured. Two areas were distinguished: one near a depression (B, see map fig. 3) and one slightly higher on the slope (A). Around sowing time, difference were very small; A (average of 3) 9.1% (by weight) and B 10.0% (also average of 3 measurements). The measuring points A and B were both located in one furrow, running along a slope (at A 0.8%, at B 1.6%). Distance between two points was approx. 20 m. Moisture was measured in area B on August 17th, in area A on August 22nd.

The results are given in table 6.

Table 6. Moisture content in soil profile at two locations.

	17/8		22/8	
	B (high)	B (low)	A (high)	A (low)
0 - 5 cm	9.5	10.4	6.4	7.1
5 - 10 cm	9.6	10.5	7.2	7.6
10 - 15 cm	9.9	11.2	8.0	8.0
15 - 20 cm	9.2	10.6	7.4	7.6
total water in 0-20 cm (mm):	19.1	21.4	14.5	15.2

On August 4th, one rainstorm of approx. 80 mm was recorded (see rainfall distribution in 1979, given in fig. 6). This storm, with high intensity rains (see fig. 8) contributed for approx. 18% to the total rain of the season (or even for 21% when rainfall in the crop growing season only is considered). Seen the results of the rainfall-runoff observations (Hoogmoed, 1980), it may be assumed, that no more than 20 - 30 mm of the rainstorm will have infiltrated on the spot. The not-infiltrated water will flow along the slope in the furrow towards a depression.

With the use of a neutron-scattering gauge, water storage in the soil profile was followed along one furrow in location B, with a distance between 2 points of approx. 80 m. Due to technical limitations, the first measurements could take place only at August 20th. The moisture in the profile between 20 and 180 cm below surface during the period 20/8 and 4/10 is given in fig. 9. It is clear that the higher moisture content of the low spot is due to run-on water from the higher areas.

Although, due to the rather favourable rainfall distribution during this rainy season no serious problems with moisture supply were encountered, in periods with longer dry spells, the higher areas may suffer from drought if runoff is not prevented.

Tied ridging.

In view of the observed runoff and the quick formation of surface crusts after rainfall, it was considered that the most simple and effective way of providing a uniform infiltration pattern will be a (semi)permanent storage for water at the soil surface. Since in the region ridges do form the base

of the cultivation system, application of a tied-ridging system may be feasible. The tied-ridging system was developed for a.o. Central and East African agricultural regions by the NIAE (FAO, 1966). Although the system was designed initially for mechanized farming in areas with rainfall of more than 800 mm, the basic principles could be applied in other regions as well. A preliminary test was carried out within the farmer's field to investigate the effect of crossdams in a ridge and furrow system.

In the field, plots were constructed with crossdams every 4 m, over a width of 5 ridges, thus covering approx. 4 m width. During the rainy season, no runoff from these plots was observed, except for the heavy shower of August 4 (80 mm). During this particular rainstorm, the crossdams were damaged and runoff occurred. The damage was restricted however (on this small scale) to the crossdams and water could flow downslope via the furrows, no crossflow started.

In fig. 10 the moisture storage is shown in the profile in plots with tied-ridges (TR) and without (C), measured by neutron probe. Two restrictions have to be noted: a. the measurements could start only on August 20th and b. since the measurements were taken in a furrow along a slope, the upstream part of the furrow will also play a role in the moisture supply, so differences shown in the figures should be regarded only as indicative.

It is clear, that tying of ridges resulted in a higher moisture storage in the soil; for location A 61% more and for location B 13%, compared to the control plots (averaged over the measuring period).

Although positive results were obtained, it should be kept in mind that the construction of the ties and the maintenance at regular time intervals is a laborious job. The system however, can be mechanized in a simple way using animal traction, involving only very low capital investment. This can be done e.g. by the introduction of tie-forming equipment like discs, mouted on a (plow)frame, or toolbar as e.g. proposed by ICRISAT (1978) pulled by animals and operated by a step wheel or manually (lifting of the discs to create the crossdams at regular distances). See FAO, (1966) and fig. 11. It is possible to calculate the distance between crossdams in a tied ridging system necessary to get a certain surface storage for water. In a system with known (or assumed) shape and dimension of ridge and furrows, the maximum distance between crossdams as a function of slope was calculated in a (unpublished) FORTRAN computer program. E.g. for a ridge system with dimensions and shape as given in fig. 12, we may supply the distance between the crossdams as

as given in table 7.

Table 7. Calculated maximum distances between crossdams, necessary to reach a required surface storage.

case	I		II		III		Dimensions (cm) used in calculation:				
	40	50	40	50	40	50	I	II	III		
req. storage (mm)											
slope (%)	0.5	23.8	16.8	39.9	31.7	18.5	11.6	A	70	70	70
	1	11.6	8.0	19.8	15.7	8.9	5.2	B	25	25	15
	1.5	7.6	5.1	13.1	10.3	5.7	2.8	H	14	18	14
	2	5.6	3.5	9.7	7.6	4.1	1.6	C	50	50	50
	2.5	4.3	2.6	7.7	6.0	3.4	1.3	F	10	10	10
	3	3.5	1.8	6.4	4.9	2.3	1.1				
	4	2.4	1.1	4.7	3.5	1.2	0.8				
	5	1.8	0.9	3.7	2.7	1.0	-				
	7	0.9	0.6	2.5	1.6	-	-				
	9	0.7	-	1.8	0.9	-	-				

From the field observations and reliefmeter measurements in the farmer's field, the following program parameters were found. A (fig. 12) was 70 cm, B ranged from 15 - 25 cm, H was maximum 20 cm immediately after tillage and decreased after some rain to 15 cm or less, F is estimated at 10 cm. So in table 7, case II could be regarded as having the most favourable dimensions for water storage and case III as the least favourable situation, which may occur after one or two rainfall events after tillage.

Effect of superficial tillage on infiltration.

The low infiltration capacity of the soil is a result of the formation of a crust on the surface. On a freshly tilled soil the infiltration rate is high, but decreases quickly under rainfall to a low, constant final rate (see Hoogmoed, 1980). Under second and consecutive rainstorms infiltration rate will be low right from the beginning of the rain. Breaking of the crust, even superficially as may be caused by a weeding operation will improve the infiltration capacity. On two locations (A and B), small plots were constructed, from which runoff water could be collected. A barrel collected -via a trough system- the runoff water of two adjacent furrows over a length of approx. 3.75 m, thus covering an area of 6 m².

In table 8, the results are given for the 2 locations, showing the runoff from regularly cultivated (weeding and crust breaking after each shower) plots and plots, where only weeds were controlled by carefully pulling out the plants. The data given in the table are the result of 5 rain events, each less than 20 mm.

Table 8. Recorded runoff from plots with different crop maintenance system:
Runoff expressed in percentage of total rain.
Average of 5 rainfall events (each less than 20 mm)

Location/treatment	slope of plot (%)	Runoff (%)
A (crust broken)	0.8	15.5
A (crusted)	0.8	60.3
B (crust broken)	1.4	7.7
B (crusted)	1.4	45.0

Effect of tillage system and rainfall on ridge shape.

The system of cultivation, used by many farmers in the region is such, that the old ridges of the previous cropping season are being reshaped. Especially in cases where the old ridge is still reasonably intact, the tillage operation is in fact hardly more than plowing up a layer of loose soil on top of the (crusted) ridge. It may be imagined, that during rainfall this new toplayer will become saturated and may be washed down in the furrow easily.

With the use of the rainsimulator, this effect has been investigated.

On plots of 1.5 x 1.5 m, ridges of 75 cm width were constructed on a slope of 2.7%. After construction, ridges were wetted under high energy spraying in order to create a crust and left to "weather" and dry for 3 weeks. The shape of the ridges was measured with a reliefmeter. On one of the plots, the ridges were wetted with 8 mm of rain (all rain applied by the simulator with an intensity of 50 mm/hr) and then superficially cultivated with a hoe, plus a reshaping. Afterwards, 16 mm of rain was given. The initial and the resulting shape of the ridges is shown in fig. 13.

On a second plot, the ridges were reshaped (without disturbing top of ridges) without prior wetting. Twenty-four mm of rain were applied after the tillage operation and relief measurements were taken again. The results

are shown in fig. 14.

Relief measurements were also taken from ridges under other rainfall simulator experiments (P3 and P4 experiments, see Hoogmoed 1980). In fig. 15 the changes in the relief of ridges are shown after being subjected to 100 mm of rain on the newly made ridges, plus 45 mm one day later and 38 mm six days later, without intermediate cultivation. Fig. 16 shows a replicate of this experiment.

The effect of rainfall on the new ridges is different from the effect on the reshaped ones; on the new ones (fig. 15 and 16), an overall consolidation of the soil is visible, whereas in the reshaped ridges (fig. 13 and 14) a filling up of the furrow bottom occurred because of soil washing down.

4. CONCLUSIONS

In attempts to improve the living conditions of the population of developing semi-arid countries, it is of extreme importance to gain a thorough knowledge of the area of attention.

Even if a research project is aiming at improvement of "technical" aspects (e.g. agricultural production), apart from knowledge of physical factors like climate, soils, crops, etc., the socio-economic environment should be studied as well. When certain technical solutions for problems are found, it should be known whether this solution (which almost inevitably would involve a change in the usual practices of the farmer) has a chance to be accepted.

In this study it was tried to find some aspects of the farmers' activities; because of the objectives of the project, special attention was paid to the farming practices, especially the activities in the field of soil preparation, sowing and crop maintenance. These activities (in particular the soil trillage) require the major part of his labour and time, necessary to produce food for him and his family.

Given the time available, it was not possible in this study rather than trying to get an impression of the "how" and "why" of the farmer's activities. In spite of these restrictions, the following conclusions could be drawn, although it should be kept in mind, that some of these conclusions may not apply to the situation in other regions.

- The timing of the activities is completely set by the climate, because of a combination of limited energy input and unfavourable soil conditions (wetting of the soil is required to start soil tillage).

The decisions when to start are taken with a strong element of reduction of risks. E.g. early in the season there was enough moisture in the top layer of the soil to start plowing. This early plowing could be applied as a primary tillage in order to leave the surface open to allow infiltration of rainwater and to have the seedbed prepared for planting, which was approx. one month later. All activities however started only at planting time, the reasoning given by the farmer that he did not want to risk something to happen to his animals so soon after the dry period (when they are in a relatively weak physical condition).

- Only little attention was given to weed control because the farmer found the activities in the irrigated paddy fields more effective. Farmers in

- the dryland area, who did not have land in the irrigated area, spent more time on their millet crops and definitely had better looking crops.
- The farmers in the area certainly felt the limitations of the available animal power and could well imagine the advantages of timeliness of operations, although they probably did not oversee the number of problems associated with use or introduction of e.g. tractors.
 - It was realized by the farmers that losses of rainwater did occur during the intensive rainfall events. Because of the nature of the soils and the topography, hardly any erosion was found. The technical possibilities for effective measures to prevent runoff losses were not available; farmers were aware of systems to prevent runoff. Application of e.g. a system of ridges along contourlines was not seen, because farmers were afraid that possible collapse of the ridges might cause crossflow and much more damage than the loss of water in their present system.
 - The present cultivation system in the area, in the form of reshaping existing ridges is a rational system, since less than 50% of the total surface will be worked. The execution of the operation however could be improved. The moldboard plow is not the most ideal tool for making ridges, although the positive effect on weed control by the inverting action of the plow should be stressed here. Our farmer was aware of this fact and - being in a financial position to buy equipment - had acquired a ridging body. Since there is only a very limited variety of implements available, this particular type of ridger was not well suited. A proper sized and shaped ridging body and possibly a weeding blade for additional weed control (shaped to follow the ridge and furrow contours) may give an improvement. It is clear that these (though slightly) improved tools require more skill of the operator; when the distance between ridges is diverging too much from the average, a weeding blade may do more harm than good.
 - Introduction of modified practices for the conservation of water on slopes and higher areas in the field requires even further changes; one of the possible ways to prevent runoff is the construction of tied ridges, a system which would fit in an existing ridge pattern. The effectiveness of this system in terms of water conservation and - of final importance - yield increase, must be investigated thoroughly, in the mean time looking for the best practical solution for the construction of the ties and the

maintenanceduring the rainy season. It will be clear that the effectiveness of such a system will depend greatly on the rainfall pattern.

- Other cultivation systems should also be investigated; it is well possible, that e.g. broader ridges (to prevent collapse and crossflow), situated along contour lines may be easier to construct and have also a beneficial effect on water conservation.
- A very important point in further research is the attention that should be paid to the interaction between the effects of tillage on soil, water and the plant. Cooperation with other disciplines is necessary for the possible succes of changes in the farming practices in this region.

5. LITERATURE

- Ahn, P.M., 1974. West African soils. Oxford Univ. Press, London, U.K.
- Arya, L.M., G.R. Blake and D.A. Farrell, 1975. A field study of soil water depletion patterns in presence of growing soybean roots.
I: Determination of hydraulic properties of soil. Soil Sci. Soc. Amer. Proc. 39: 424-430.
- Bolton, F.E. and D.E. Booster, 1977. Tillage, moisture conservation and water use efficiency for dryland cereal production in winter rainfall regions. Proc. Int. Symp. Rainfed Agric. in semi-arid regions, Riverside, USA: 552-588.
- Buntjer, B.J., 1971. Aspects of the Hausa system of cultivation around Zaria. Samaru Agric. Newsletter 13 (2): 17-20.
- Charreau, C., 1977. Some controversial technical aspects of farming systems in semi-arid West Africa. Proc. Int. Symp. Rainfed Agric. in semi-arid regions, Riverside, USA: 313-360.
- Charreau, C. and R. Nicou, 1971. L'amélioration du profil cultural dans les sols sableux et sablo-agricoles de la zone tropicale sèche Ouest-Africaine et ses incidences agronomiques. L'Agronomie Tropicale XXVI: 209-255, 531-565, 903-978, 1183-1247.
- Cochemé, J. and P. Franquin, 1967. An agroclimatology survey of a semi-arid area in Africa south of the Sahara. W.M.O. Technical Note No. 86.
- Davy, E.G., F. Mattei and S.I. Solomon, 1976. An evaluation of climate and water resources for development of agriculture in the Sudano-Sahelian zone of West Africa. W.M.O. Special Environment Report No. 9.
- Doolette, J.B., 1977. The application of the Australian ley-farming system in North Africa. Proc. Int. Symp. Rainfed Agric. in semi-arid regions: 589-608.
- F.A.O., 1966. Equipment and methods for tied-ridging. F.A.O. Informal Working Bulletin. No. 28.
- Harrison Church, R.J., 1970. West Africa, a study of the environment and of man's use to it. Longman London.

- Hoogmoed, W.B., 1978. Report of a visit to Mali. Tillage Laboratory, Agricultural University, Wageningen.
- Hoogmoed, W.B., 1980. Report of the research activities in Mali, summer 1979. Report 1980, no. 1. Tillage Laboratory, Agricultural University, Wageningen.
- ICRISAT, 1979. Report of work 1977-1978: Farm Power and Equipment program. Internal Report ICRISAT, Hyderabad, India.
- Irvine, F.R., 1976. West African Crops. Oxford University Press, London.
- Isom, W.H. and G.F. Worker, 1979. Crop management in semi-arid environments In: Agriculture in semi-arid environments (A.E. Hall et al, eds.) Ecological Studies No. 34, Springer Verlag, Berlin: 200-223.
- Jones, M.J. and A. Wild, 1975. Soils of the West African Savanna. Technical communication no. 55. Comm. Bureau of Soils, Harpenden U.K.
- Kassam, A.H., 1976. Crops of the West African semi-arid tropics. ICRISAT Hyderabad, India.
- Kassas, M., 1970. Desertification versus potential for recovery in Circum-Saharan territories. In: Arid lands in transition, AAAS publ.-123-142.
- Kievit, D.T.I., 1980. Observaties van de activiteiten van een locale boer in Mali, zomer 1979 (in Dutch). Scriptie, Tillage Laboratory, Agricultural University, Wageningen.
- Kouwenhoven, J.K., 1979. Simple relief meter for soil cultivation studies. A.M.A. Vol X (2): 37-38
- Morgan, W.B. and J.C. Pugh, 1969. West Africa. Methuen, London, U.K.
- Oram, P. 1977. Agriculture in the semi-arid regions: problems and opportunities. Proc. Int. Symp. Rainfed Agric. in semi-arid regions. Riverside, U.S.A.: 2-59.
- Rawitz, E., W.B. Hoogmoed and Y. Morin, 1980. Summary technical report on research activities in Israel and Holland on the effects of primary tillage, crust control and modification on crop response, soil infiltrability and water conservation measure effectiveness. Report 1980 no.2, Tillage Laboratory, Wageningen.

Ruthenberg, H. 1971. Farming systems in the tropics. Clarendon Press, Oxford
U.K.

Stroosnijder, L., 1977. Aspects of soil and water in the Sahel in Mali.
Proc. Int. Symp, Rainfed Agric. in semi-arid regions.
Riverside, U.S.A. 166-199.

W.M.O., 1973. Agroclimatology in the semi-arid areas south of the Sahara.
Proceedings of a regional technical conference, Febr. 1971.
W.M.O. publ. no. 340.

ANNEX

LIST OF FIGURES.

- Fig. 1. Map of West Africa.
- " 2. Climatic data for West Africa (500-700 mm rainfall zone).
- " 3. Lay out of the farmer's field.
- " 4. K and ψ relations vs. θ for soil at farm.
- " 5. Penetrometer resistance and m.c. at time and depth of measurement.
- " 6. Daily rainfall 1979.
- " 7. Relief measurements in farmer's field.
- " 8. Intensity distribution in season's largest rainstorm.
- " 9. Moisture storage in soil: low and high spot along furrow.
- " 10. Moisture storage in soil: tied ridges vs. control.
- " 11. Ridge tying unit.
- " 12. Plan of a tied ridging system.
- " 13. Ridge shapes Mali experiments 1979 (reliefmeter measurements).
- " 14. -- do --
- " 15. -- do --
- " 16. -- do --

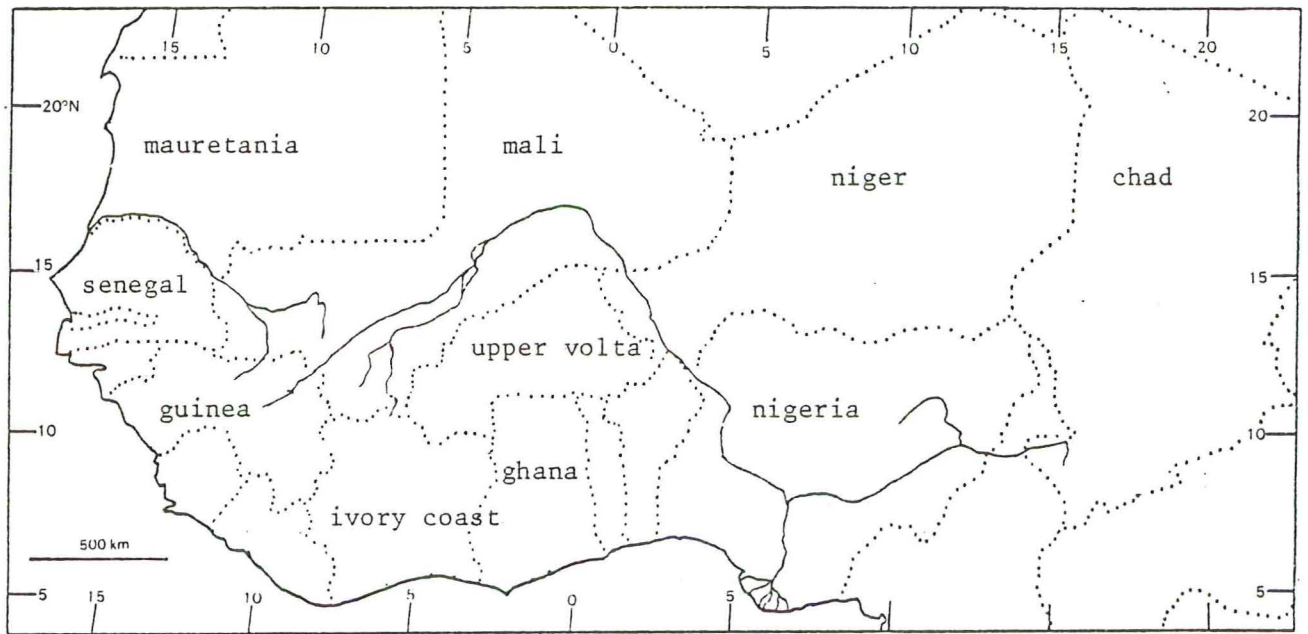

Fig. 1. Map of West Africa.

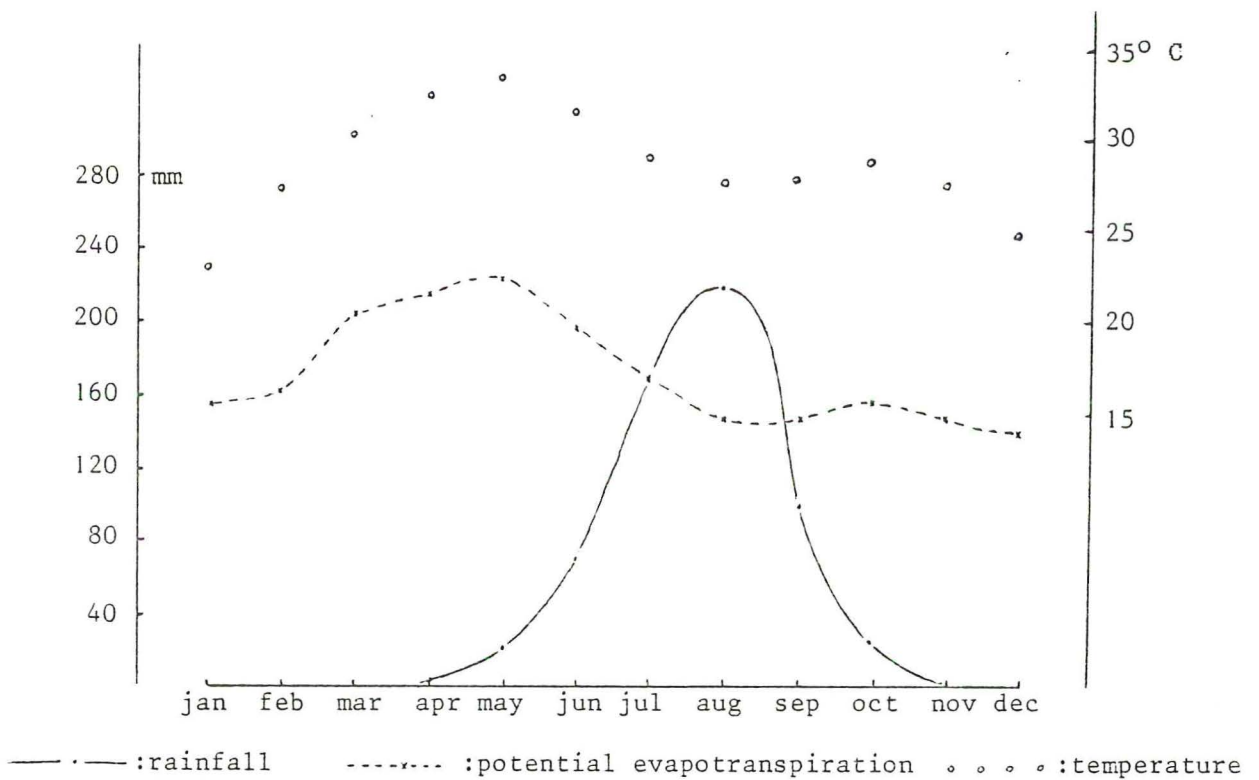
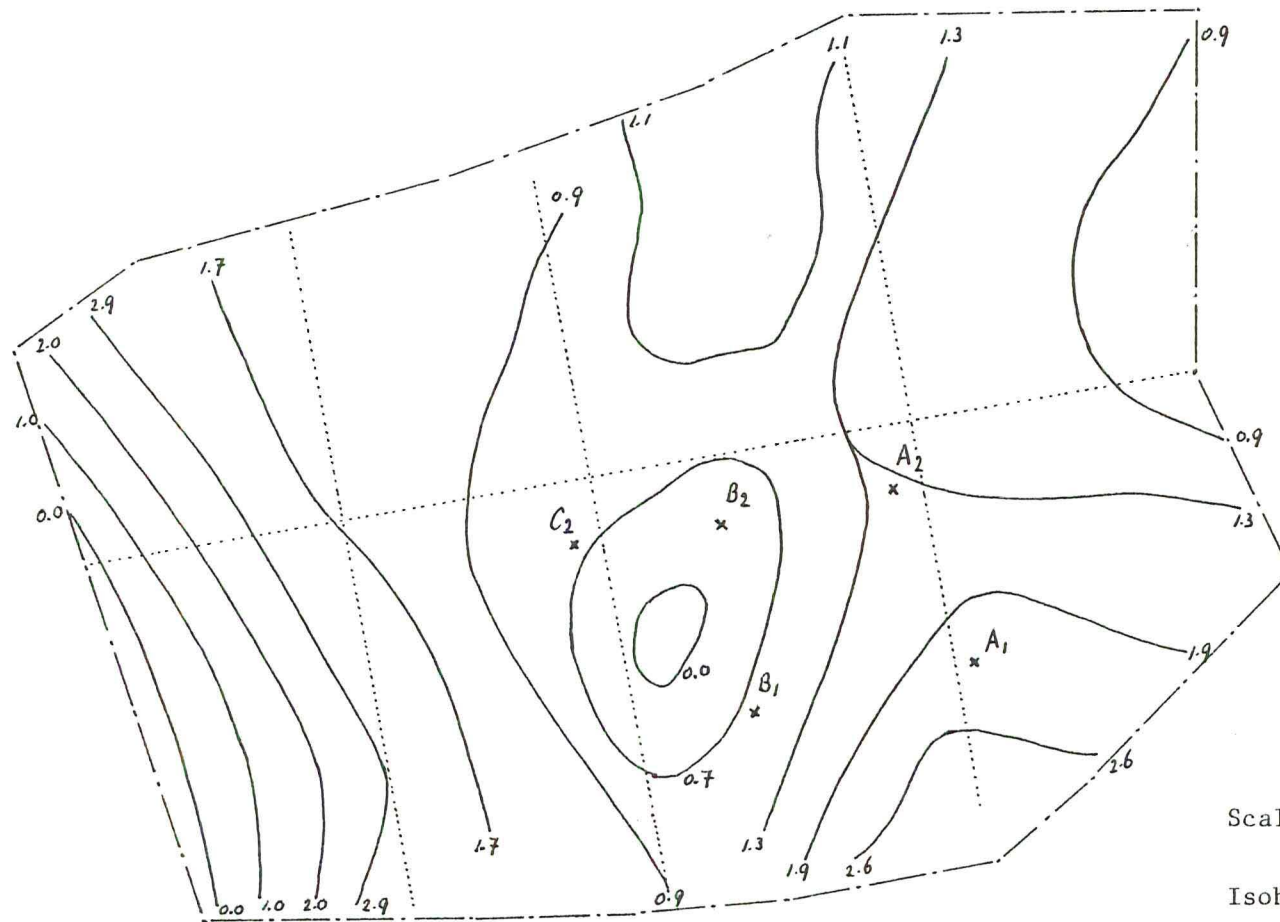

Fig. 2. Climatic data for West Africa: region 500 - 700 mm rainfall (including Mali), after Davy et al (1976).



Scale 1 : 5000

Isohypses in meters

(Note: not equidistant!)

Fig.3. Lay out of the farmer's field. Total area: approx. 39 hectares.

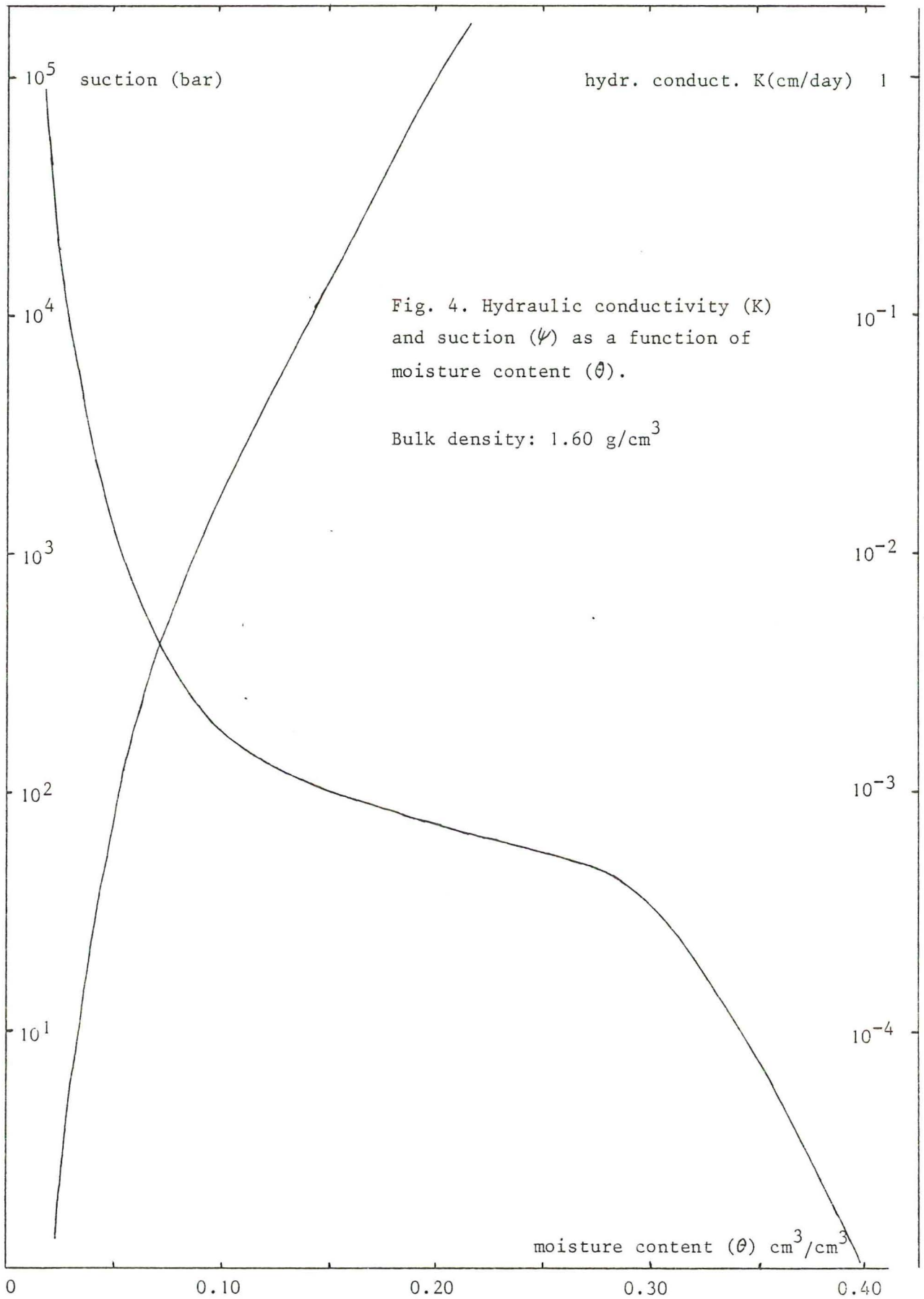

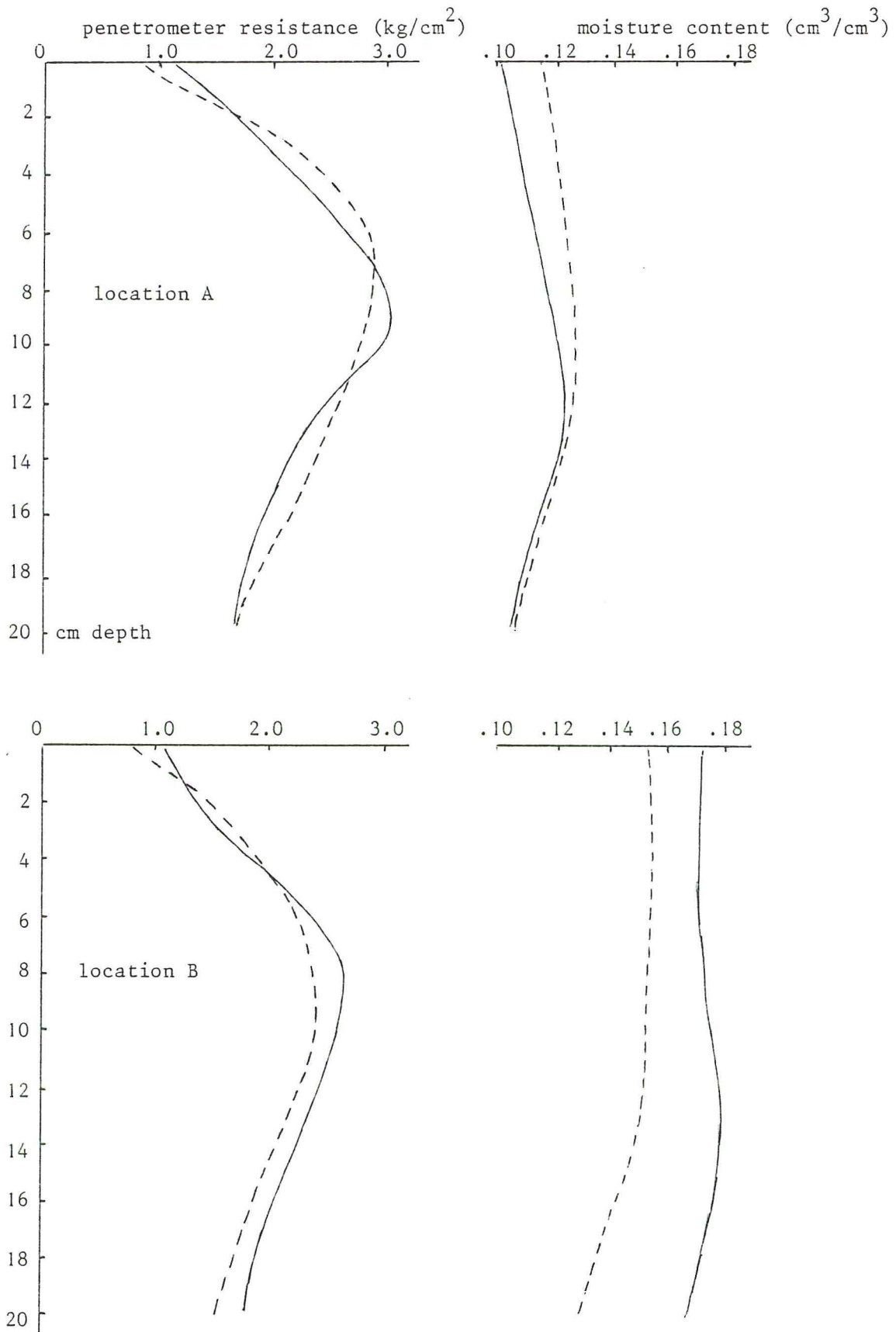

Fig. 5. Penetrometer resistance and moisture content at time and depth of measurement.

Fig. 6. Daily rainfall on farmer's field.

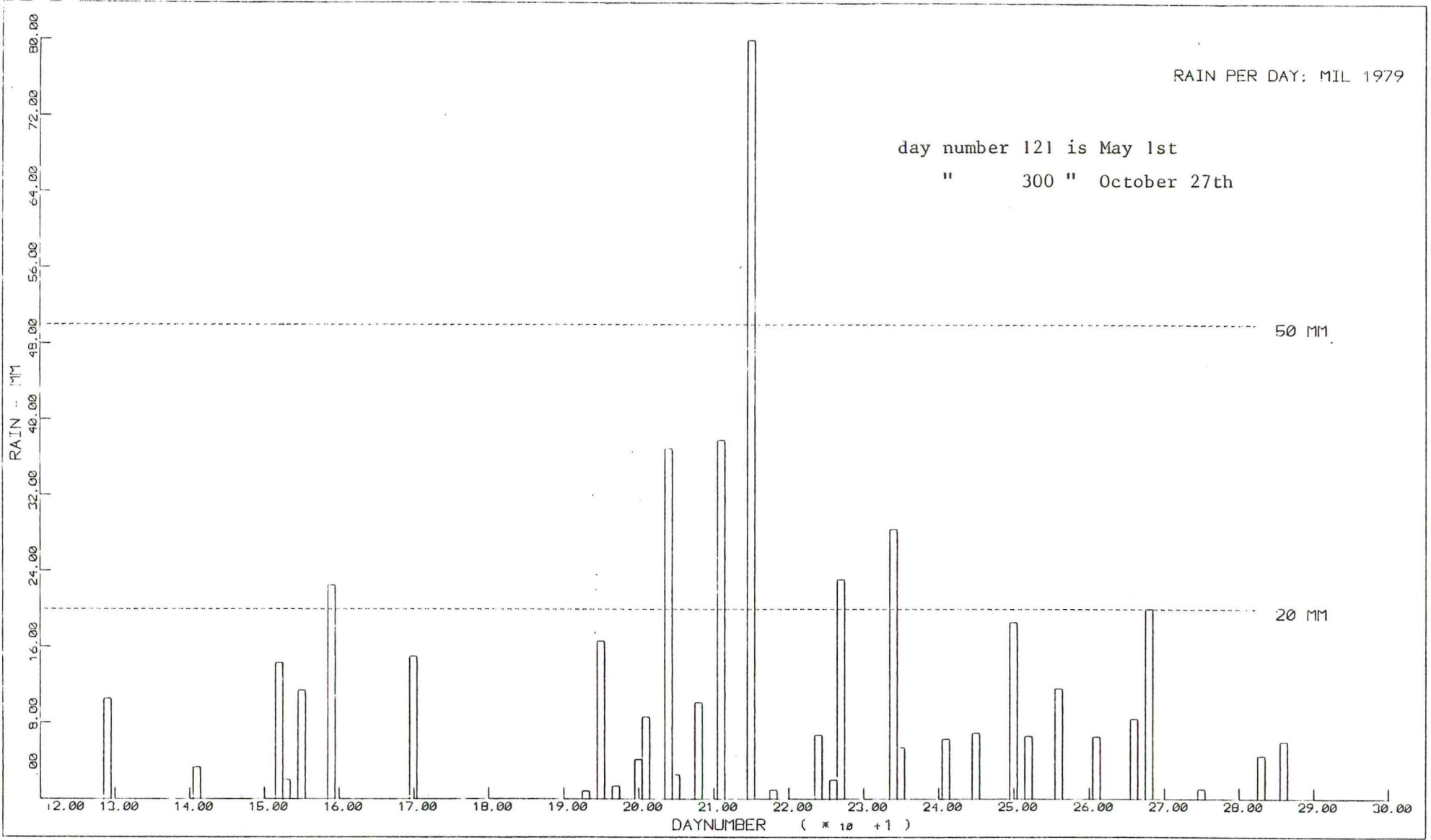

Fig. 7. Relief measurements in farmer's field

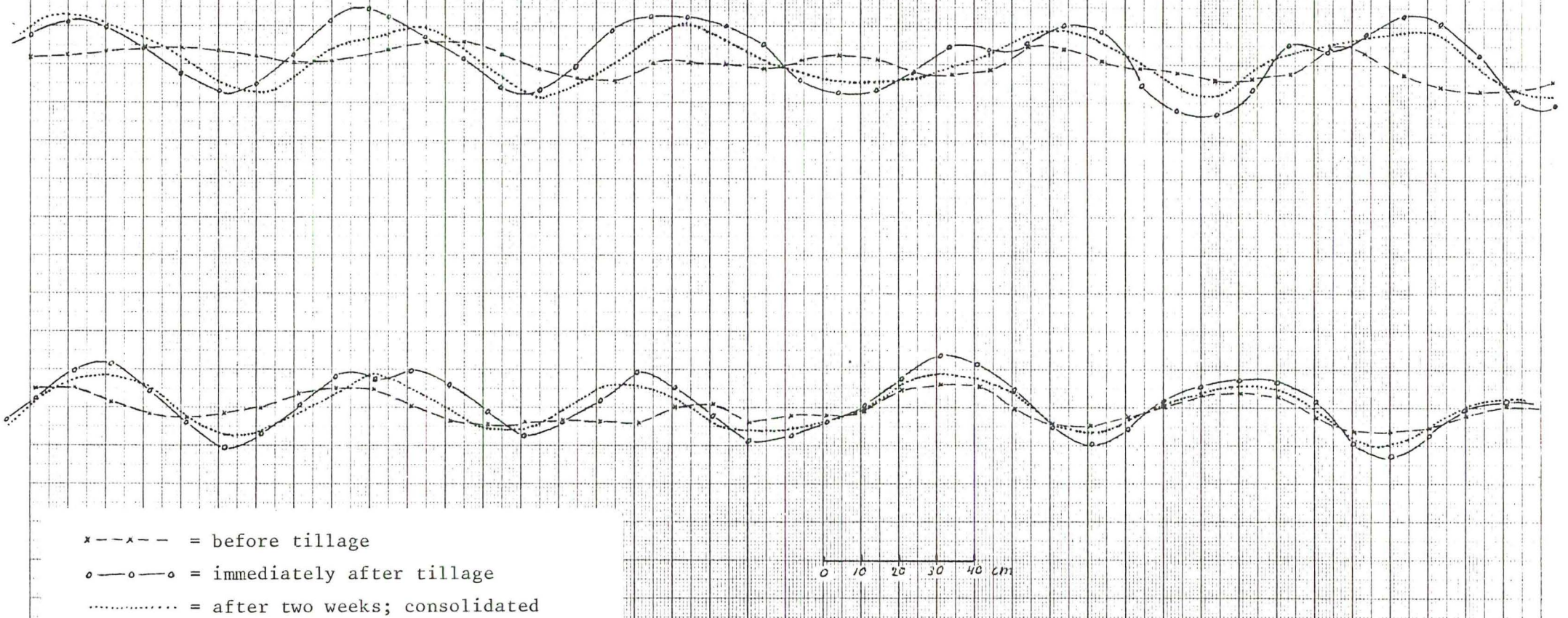
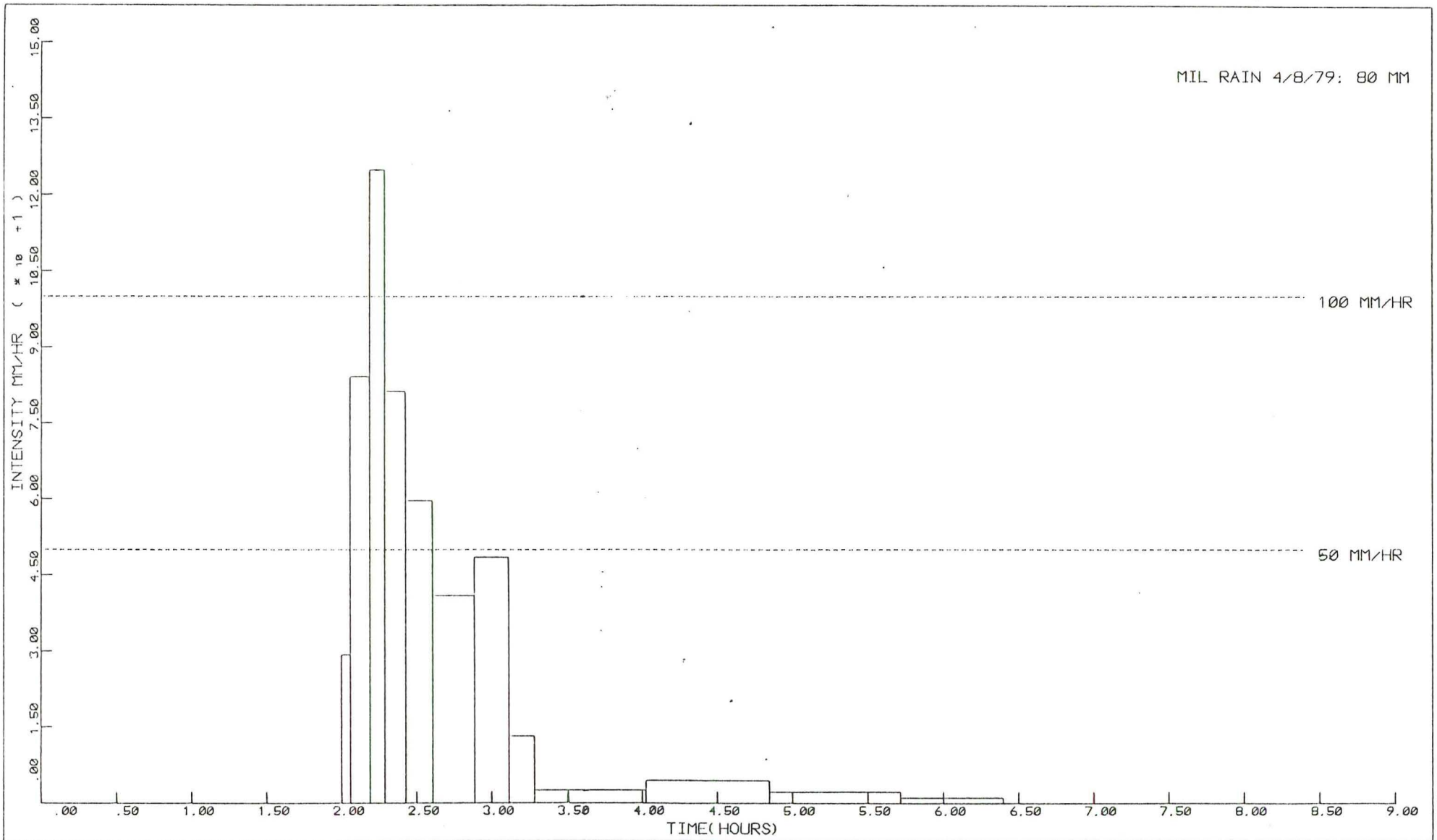

Fig. 8. Intensity distribution of largest rainstorm.



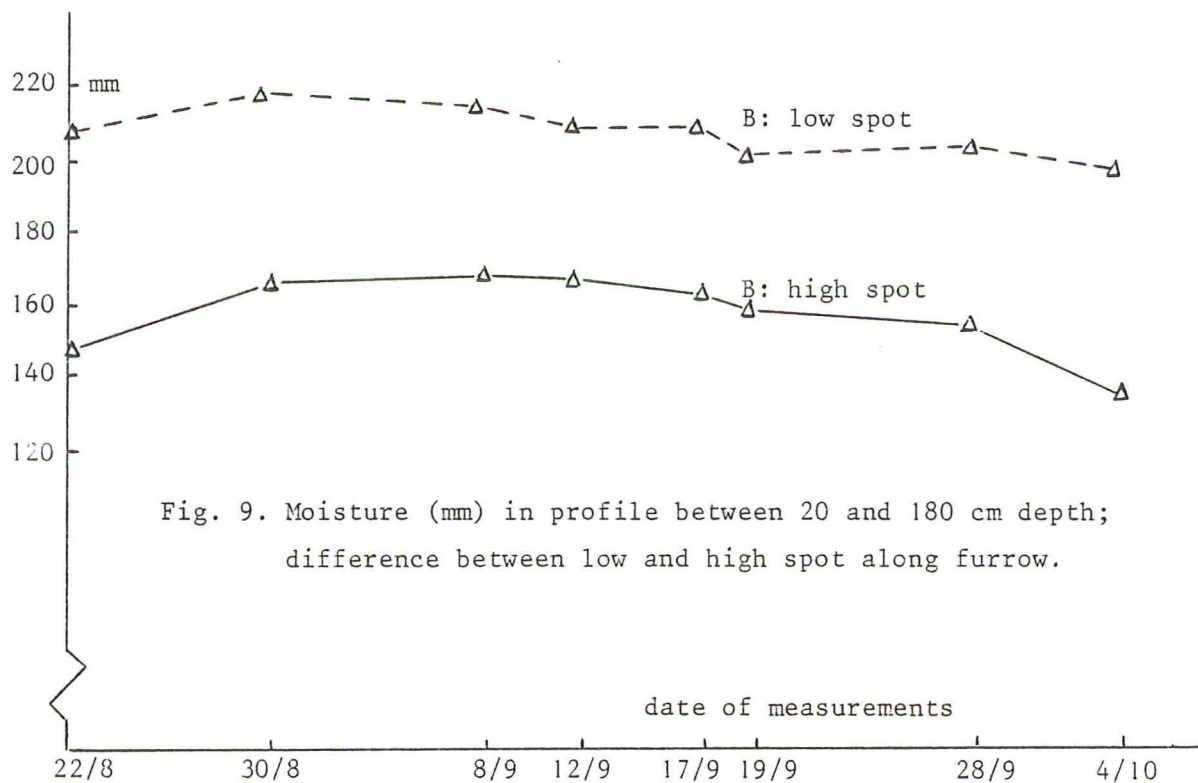

Fig. 9. Moisture (mm) in profile between 20 and 180 cm depth; difference between low and high spot along furrow.

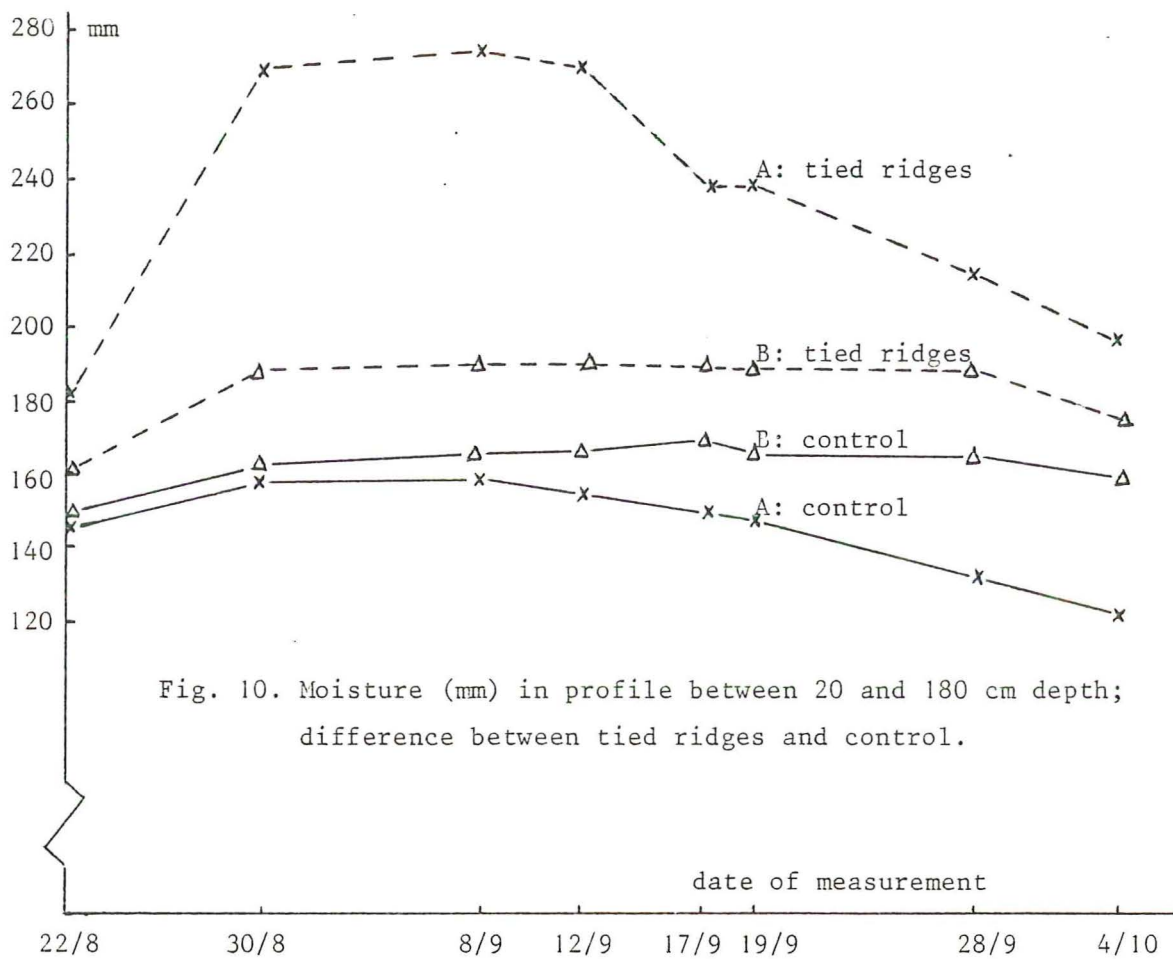

Fig. 10. Moisture (mm) in profile between 20 and 180 cm depth; difference between tied ridges and control.

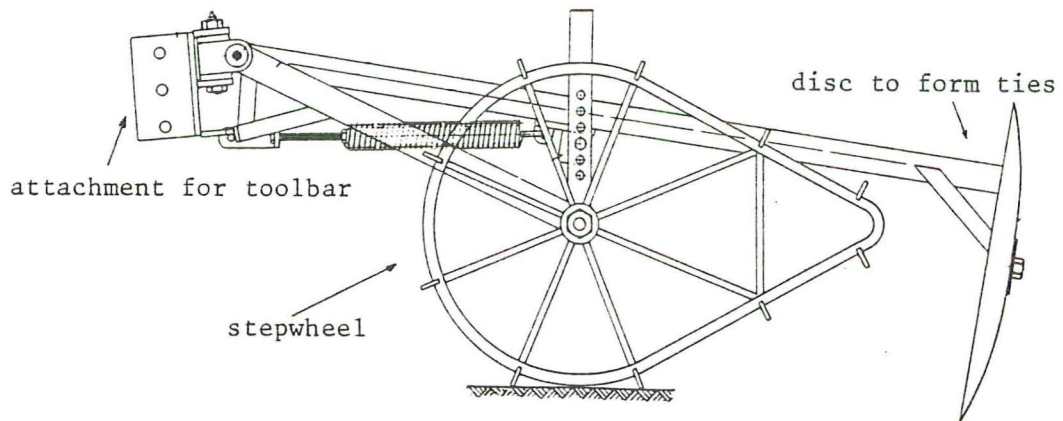

Fig. 11. Ridge tying unit, as developed by NIAE (FAO,1966).

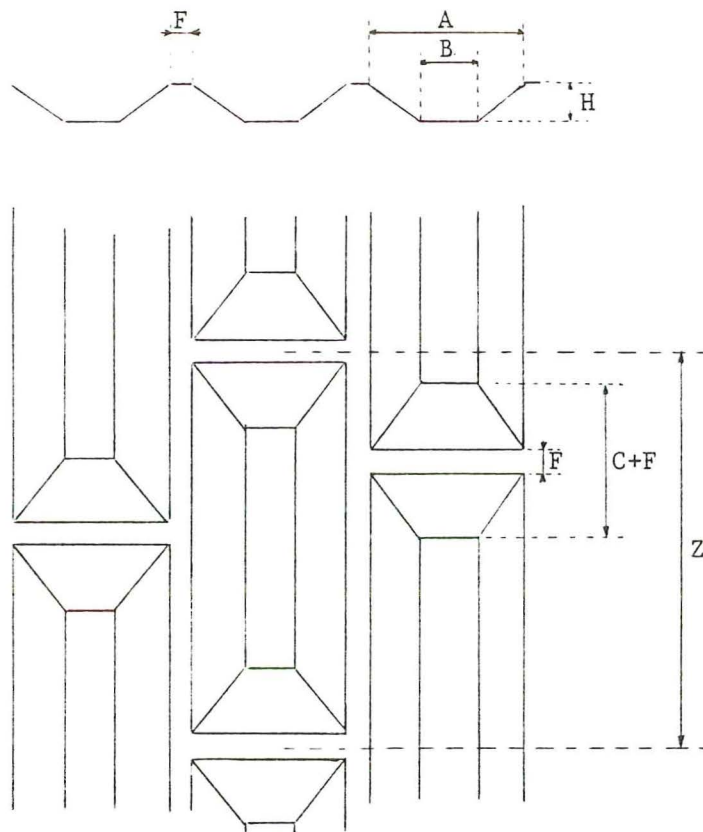

Fig.12.Cross section and aerial view of a tied ridging system, as used for the calculation of distance Z.

Fig. 13. Ridge shapes Mali experiments 1979

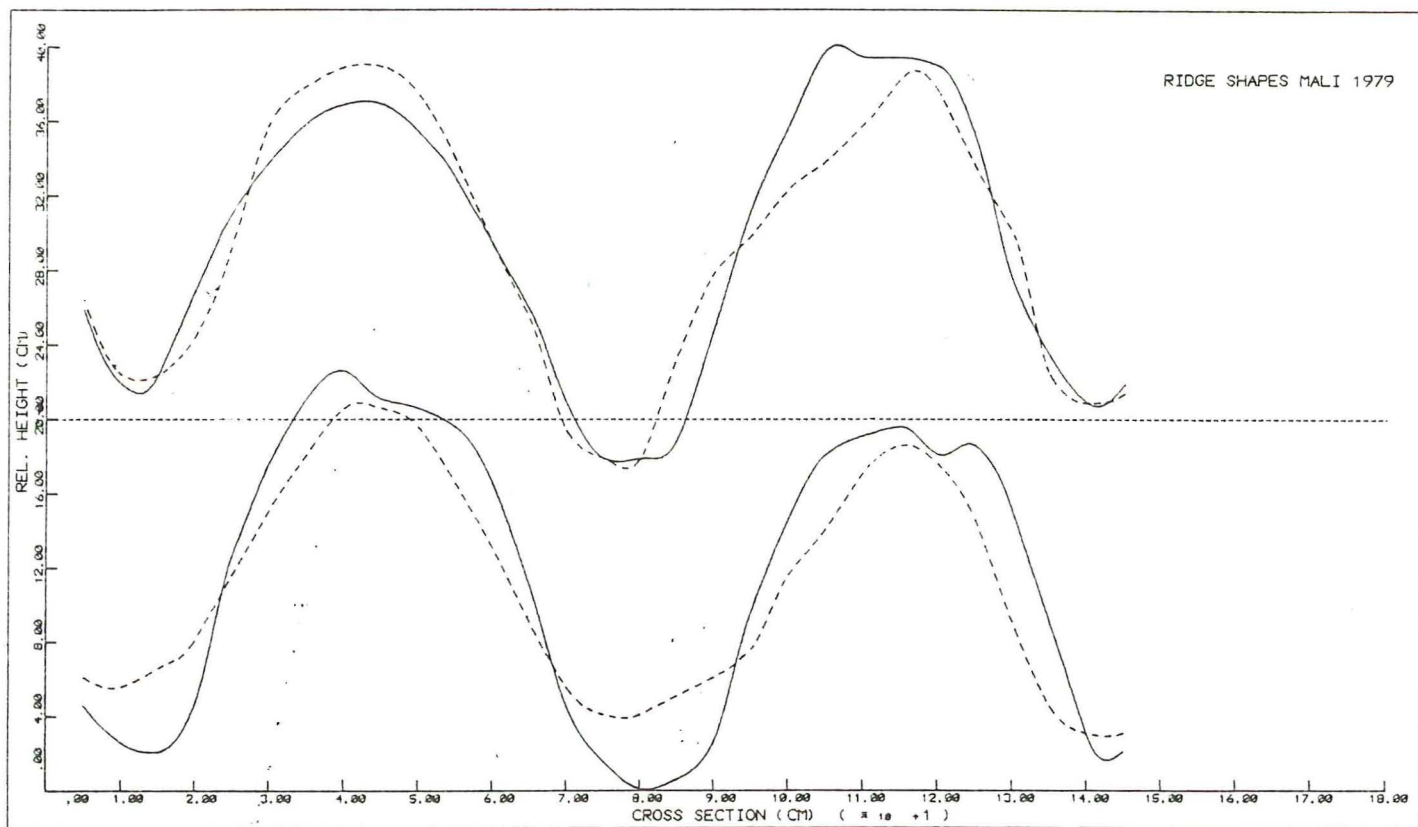

Fig. 14. Ridge shapes Mali experiments 1979

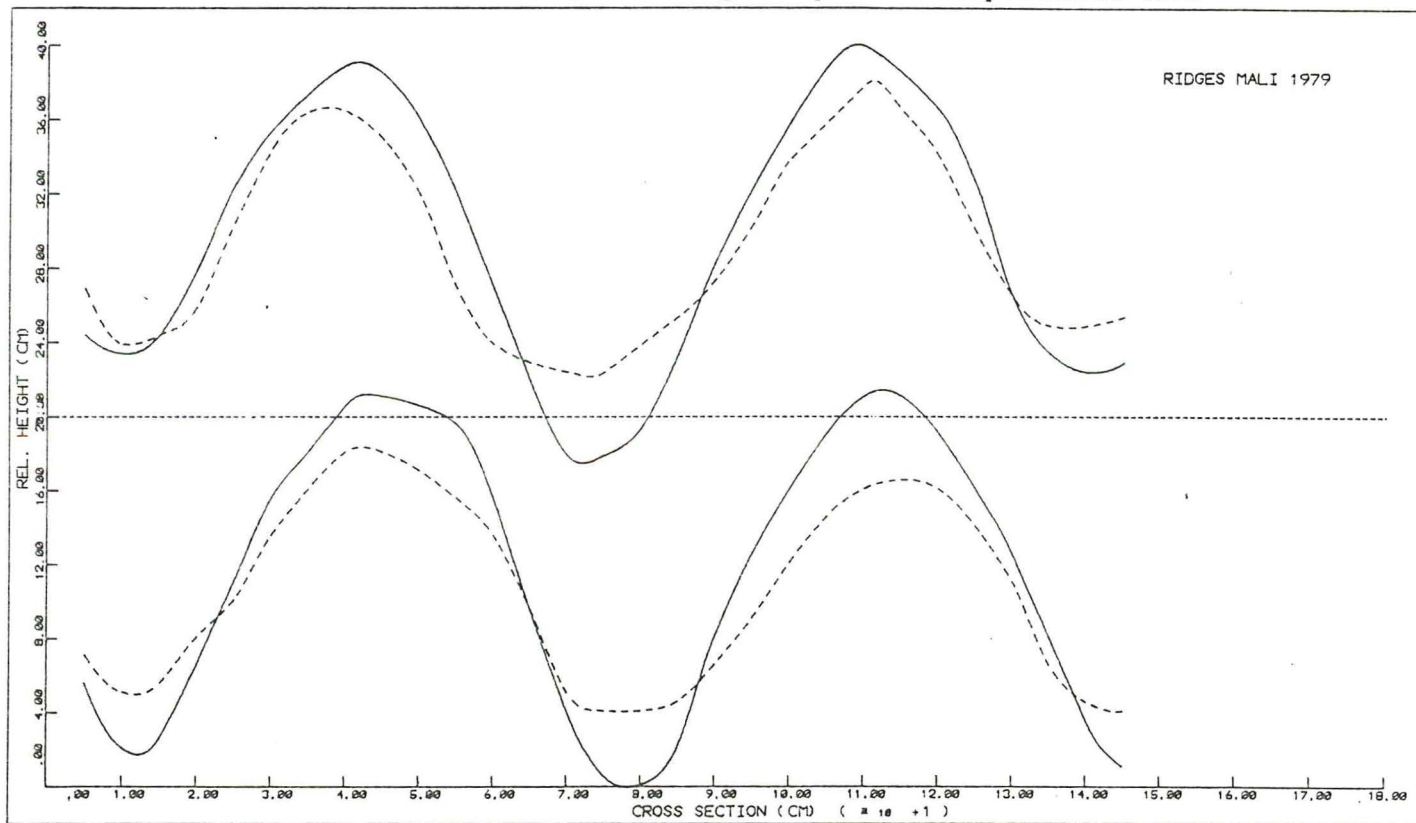

Fig. 15. Ridge shapes Mali 1979

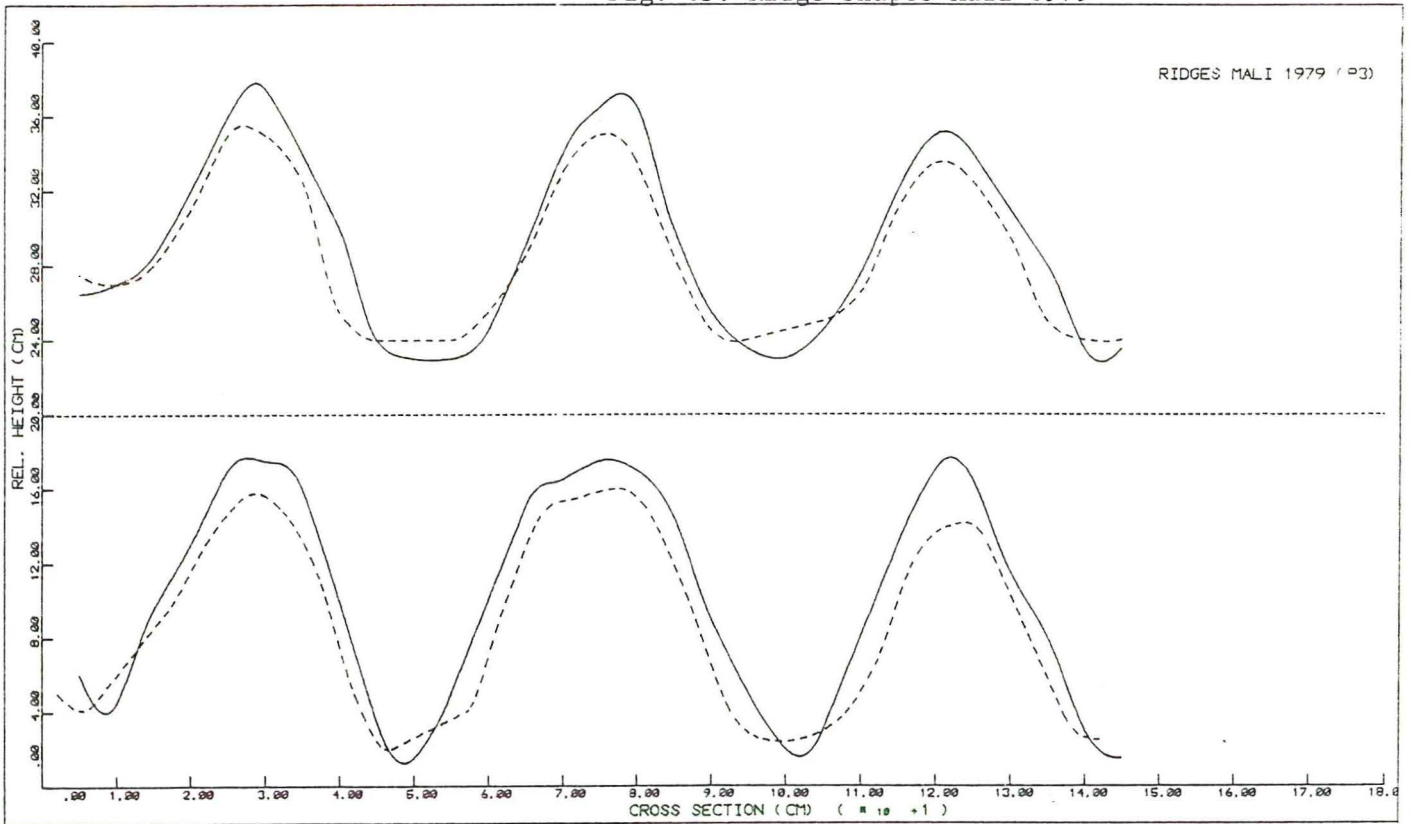
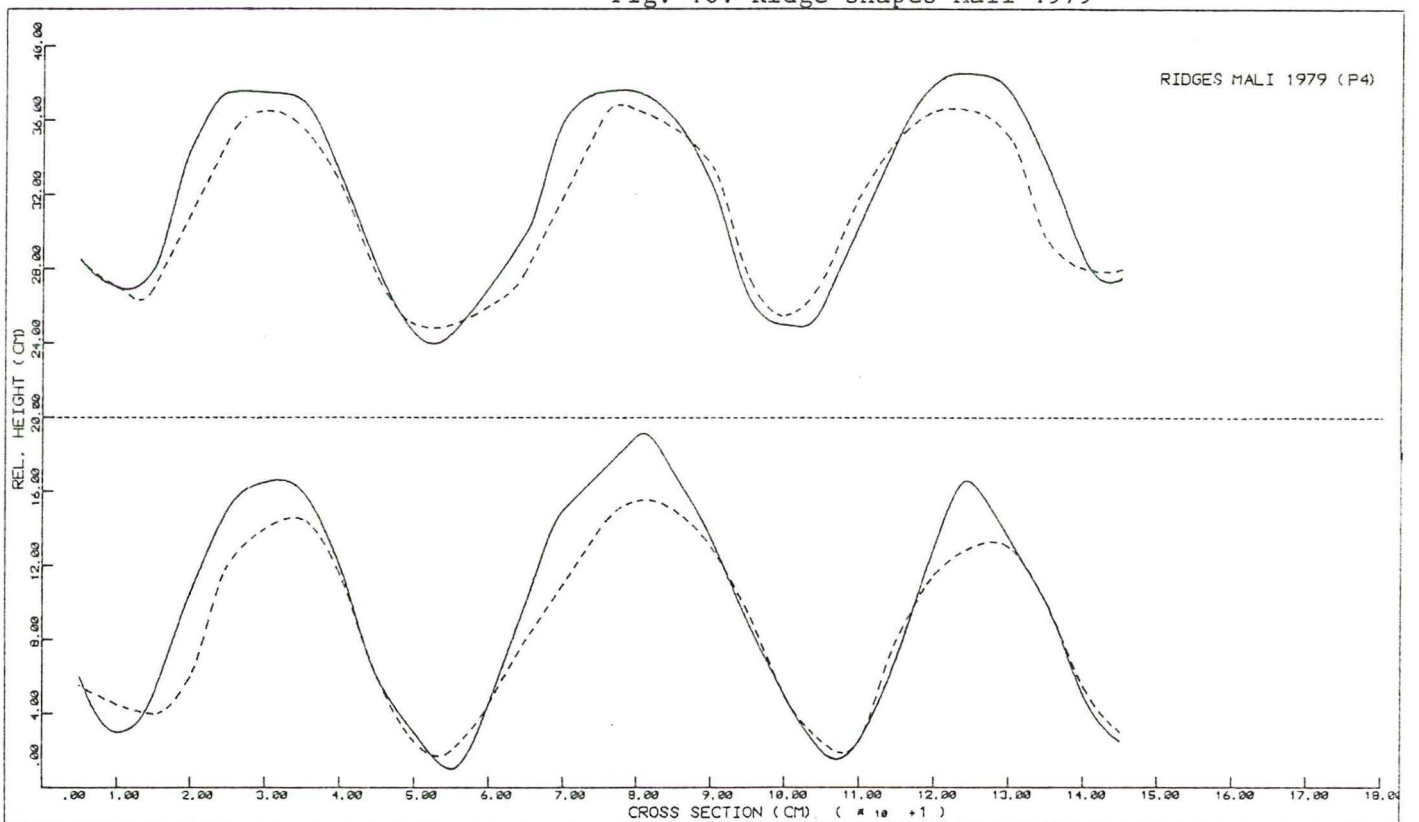

Fig. 16. Ridge shapes Mali 1979



maintained during the rainy season. It will be clear that the effectiveness of such a system will depend greatly on the rainfall pattern.

- Other cultivation systems should also be investigated; it is well possible, that e.g. broader ridges (to prevent collapse and crossflow), situated along contour lines may be easier to construct and have also a beneficial effect on water conservation.
- A very important point in further research is the attention that should be paid to the interaction between the effects of tillage on soil, water and the plant. Cooperation with other disciplines is necessary for the possible success of changes in the farming practices in this region.

5. LITERATURE

- Ahn, P.M., 1974. West African soils. Oxford Univ. Press, London, U.K.
- Arya, L.M., G.R. Blake and D.A. Farrell, 1975. A field study of soil water depletion patterns in presence of growing soybean roots.
I: Determination of hydraulic properties of soil. Soil Sci. Soc. Amer. Proc. 39: 424-430.
- Bolton, F.E. and D.E. Booster, 1977. Tillage, moisture conservation and water use efficiency for dryland cereal production in winter rainfall regions. Proc. Int. Symp. Rainfed Agric. in semi-arid regions, Riverside, USA: 552-588.
- Buntjer, B.J., 1971. Aspects of the Hausa system of cultivation around Zaria. Samaru Agric. Newsletter 13 (2): 17-20.
- Charreau, C., 1977. Some controversial technical aspects of farming systems in semi-arid West Africa. Proc. Int. Symp. Rainfed Agric. in semi-arid regions, Riverside, USA: 313-360.
- Charreau, C. and R. Nicou, 1971. L'amélioration du profil cultural dans les sols sableux et sablo-agricoles de la zone tropicale sèche Ouest-Africaine et ses incidences agronomiques. L'Agronomie Tropicale XXVI: 209-255, 531-565, 903-978, 1183-1247.
- Cochemé, J. and P. Franquin, 1967. An agroclimatology survey of a semi-arid area in Africa south of the Sahara. W.M.O. Technical Note No. 86.
- Davy, E.G., F. Mattei and S.I. Solomon, 1976. An evaluation of climate and water resources for development of agriculture in the Sudano-Sahelian zone of West Africa. W.M.O. Special Environment Report No. 9.
- Doolette, J.B., 1977. The application of the Australian ley-farming system in North Africa. Proc. Int. Symp. Rainfed Agric. in semi-arid regions: 589-608.
- F.A.O., 1966. Equipment and methods for tied-ridging. F.A.O. Informal Working Bulletin. No. 28.
- Harrison Church, R.J., 1970. West Africa, a study of the environment and of man's use to it. Longman London.

- Hoogmoed, W.B., 1978. Report of a visit to Mali. Tillage Laboratory, Agricultural University, Wageningen.
- Hoogmoed, W.B., 1980. Report of the research activities in Mali, summer 1979. Report 1980, no. 1. Tillage Laboratory, Agricultural University, Wageningen.
- ICRISAT, 1979. Report of work 1977-1978: Farm Power and Equipment program. Internal Report ICRISAT, Hyderabad, India.
- Irvine, F.R., 1976. West African Crops. Oxford University Press, London.
- Isom, W.H. and G.F. Worker, 1979. Crop management in semi-arid environments In: Agriculture in semi-arid environments (A.E. Hall et al, eds.) Ecological Studies No. 34, Springer Verlag, Berlin: 200-223.
- Jones, M.J. and A. Wild, 1975. Soils of the West African Savanna. Technical communication no. 55. Comm. Bureau of Soils, Harpenden U.K.
- Kassam, A.H., 1976. Crops of the West African semi-arid tropics. ICRISAT Hyderabad, India.
- Kassas, M., 1970. Desertification versus potential for recovery in Circum-Saharan territories. In: Arid lands in transition, AAAS publ.-123-142.
- Kievit, D.T.I., 1980. Observaties van de activiteiten van een locale boer in Mali, zomer 1979 (in Dutch). Scriptie, Tillage Laboratory, Agricultural University, Wageningen.
- Kouwenhoven, J.K., 1979. Simple relief meter for soil cultivation studies. A.M.A. Vol X (2): 37-38
- Morgan, W.B. and J.C. Pugh, 1969. West Africa. Methuen, London, U.K.
- Oram, P. 1977. Agriculture in the semi-arid regions: problems and opportunities. Proc. Int. Symp. Rainfed Agric. in semi-arid regions. Riverside, U.S.A.: 2-59.
- Rawitz, E., W.B. Hoogmoed and Y. Morin, 1980. Summary technical report on research activities in Israel and Holland on the effects of primary tillage, crust control and modification on crop response, soil infiltrability and water conservation measure effectiveness. Report 1980 no.2, Tillage Laboratory, Wageningen.

Ruthenberg, H. 1971. Farming systems in the tropics. Clarendon Press, Oxford
U.K.

Stroosnijder, L., 1977. Aspects of soil and water in the Sahel in Mali.
Proc. Int. Symp, Rainfed Agric. in semi-arid regions.
Riverside, U.S.A. 166-199.

W.M.O., 1973. Agroclimatology in the semi-arid areas south of the Sahara.
Proceedings of a regional technical conference, Febr. 1971.
W.M.O. publ. no. 340.

ANNEX

LIST OF FIGURES.

- Fig. 1. Map of West Africa.
- " 2. Climatic data for West Africa (500-700 mm rainfall zone).
- " 3. Lay out of the farmer's field.
- " 4. K and ψ relations vs. θ for soil at farm.
- " 5. Penetrometer resistance and m.c. at time and depth of measurement.
- " 6. Daily rainfall 1979.
- " 7. Relief measurements in farmer's field.
- " 8. Intensity distribution in season's largest rainstorm.
- " 9. Moisture storage in soil: low and high spot along furrow.
- " 10. Moisture storage in soil: tied ridges vs. control.
- " 11. Ridge tying unit.
- " 12. Plan of a tied ridging system.
- " 13. Ridge shapes Mali experiments 1979 (reliefmeter measurements).
- " 14. -- do --
- " 15. -- do --
- " 16. -- do --