

Introduction to farm surveys

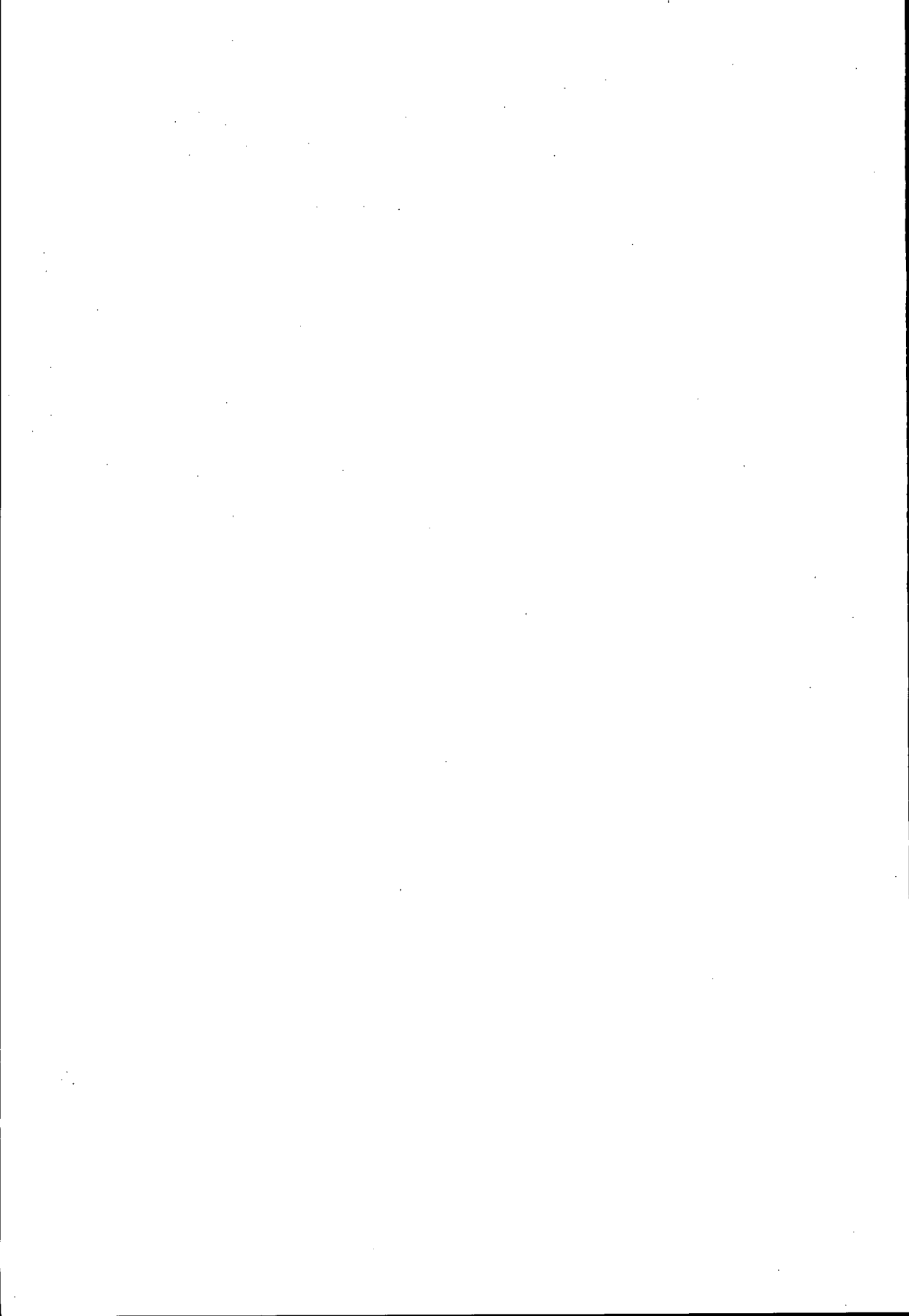

Introduction to farm surveys

Josette Murphy and Leendert H. Sprey



International Institute for Land Reclamation and Improvement/ILRI
P.O. Box 45, 6700 AA Wageningen, The Netherlands 1986.

The work of Dr. Murphy has been financed by the Upper Volta Office of the United States Agency for International Development under contract PSC 686-092-080.

© International Institute for Land Reclamation and Improvement ILRI, Wageningen,
The Netherlands 1986.
This book or any part thereof must not be reproduced in any form without the written permission
of ILRI.

Earlier edition © 1983 by International Institute for Land Reclamation and Improvement (ILRI),
Wageningen, The Netherlands.

ISBN 9070260905

Printed in The Netherlands.

HOW TO USE THIS BOOK

This book is intended for enumerators with a level of education of some years of secondary school. The book can be used in three different ways:

- A. In independent study by the enumerators themselves;
- B. In a training course that prepares the enumerators before they start their survey work;
- C. In on-the-job training sessions for enumerators whilst they are engaged in surveys.

A Independent study

The text of the book will be understandable to an enumerator with some experience in survey work. For independent study, the student is advised to read the chapters in their numerical order because they start with simple matters and move on to more complex ones as the book progresses. At the end of each chapter is a set of exercises or questions which allow the student to check whether he has understood the contents of the chapter. He can find the answers to the calculations at the back of the book.

The student will find it helpful to discuss the subjects he has studied with his colleagues, his superiors, and with extension agents.

B Training course before a survey

In a training course, the enumerators in a project are brought together to be trained before they commence their work. During the course, the objectives of the survey and the work the enumerators will be required to do should be explained to them. This can best be done on the basis of an 'Enumerator's Manual' - a document specially written for each survey program to be undertaken. This manual should describe, step-by-step, the work that will be done (how to fill in the survey forms, how to solve problems that may arise during the surveys, and so on). The teacher can base his course on that manual and the present book.

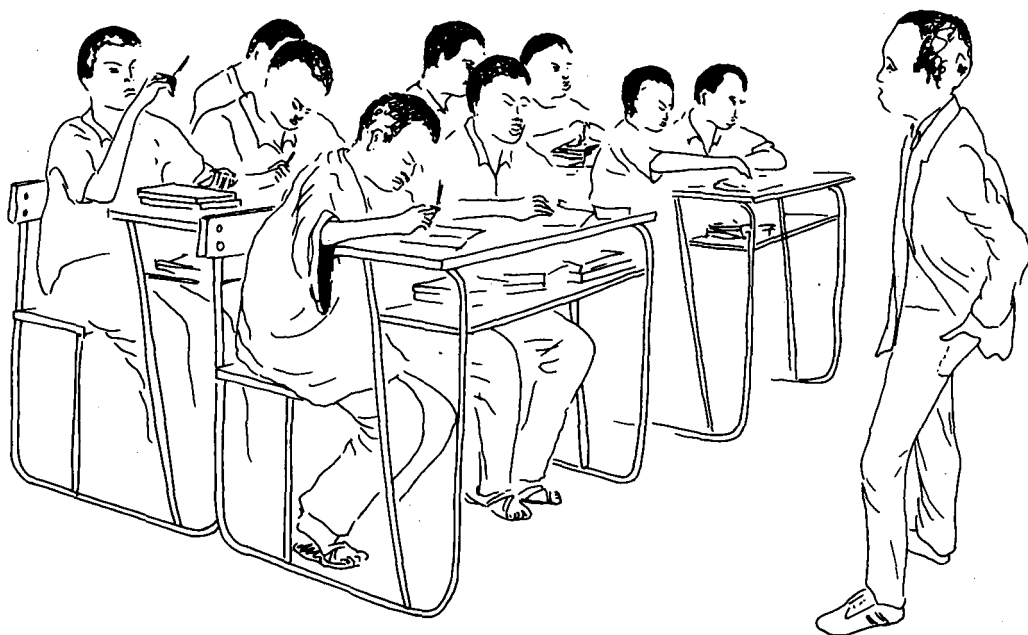

Training before the surveys begin

C On-the-job training sessions

At regular intervals, say once a month, the enumerators in a project (or in one region of a large project) can be brought together for a one-day training session. They should be requested to read one chapter of this

book (or part of one chapter) at home *before* the training session, and to try to do the exercises and answer the questions listed at the end of the chapter. During the training session, the teacher should check whether the enumerators have understood the pages studied, should explain any point that was not clear to them, and should discuss the solutions to the exercises. He should explain how the knowledge they have acquired from the chapter can help them in understanding their work and how it fits in with their work program.

Some chapters are more difficult or longer than others. If necessary, they can be split up and treated in more than one session. Others can be combined. The order of the chapters can be changed to fit the needs of the project, and especially to coincide with the crop calendar.

For example: Chapter 10 explains how to measure fields. If the enumerators will be required to do this work shortly after training begins, it may be best to study Chapter 10 before the other chapters.

CONTENTS

	HOW TO USE THIS BOOK	v
A	Independent study	v
B	Training course before a survey	vi
C	On-the-job training sessions	vi
1	INTRODUCTION	1
1.1	Purpose of this book	1
1.2	Background of the book	1
	Chapter 1 : Questions	4
2	ORGANIZING FARM SURVEYS	5
2.1	The need for information	5
2.2	The role of a monitoring and evaluation unit	8
2.3	The role of the enumerator	10
	Chapter 2 : Questions	11
3	INTRODUCING THE SURVEY	12
3.1	Village meeting	13
3.2	Visiting the farmers in the sample	15
3.3	Building up a good relationship with the farmers	17
	Chapter 3 : Questions	19
4	DATA-GATHERING METHODS	20
4.1	Observations and interviews	20
4.2	Single and repeated interviews and observations	22

4.3	Open-ended and multiple-choice questions	23
4.4	The wording of questions	25
	Chapter 4 : Questions	28
5	OBTAINING THE DATA	29
5.1	The survey forms	29
5.2	An 'Enumerator's Manual'	33
5.3	A regular schedule of interviews	33
5.4	Recording understandable data	34
5.5	Visiting the fields	34
5.6	Surveys of long duration	36
	Chapter 5 : Questions	37
6	SELECTING A SAMPLE	38
6.1	Population and sample	38
6.2	A representative sample	39
6.3	Random sample	41
6.4	Stratified random sample	42
6.5	Size of the sample	43
6.6	Generalizations from sample data	44
	Chapter 6 : Questions	46
7	SUMMARIZING THE DATA	47
7.1	General	47
7.2	Tabulation	48
7.3	Averages	48
7.4	Dispersion	51
	Chapter 7 : Questions	53
8	FREQUENCY DISTRIBUTIONS	54
8.1	Frequencies	54
8.2	Relative frequencies	57
8.3	Graphic presentation of frequency tables	58
	Chapter 8 : Questions	61
9	RELATIVE CHANGES	63
9.1	General	63

9.2	Constant increase	65
9.3	Ratios	66
9.4	Graphic presentation of changes over time	69
	Chapter 9 : Questions	71
10	MEASURING FIELDS	72
10.1	Geometry	72
10.2	Measuring distances	75
10.3	Measuring angles	77
10.4	Measuring a field	81
	Chapter 10 : Questions	83
11	ESTIMATING CROP PRODUCTION	85
11.1	The use of scales	85
11.2	Direct estimates of crop production	88
11.3	Indirect estimates of crop production	90
	Chapter 11 : Questions	94
12	SOURCES OF ERROR IN DATA	95
12.1	Sample errors	96
12.2	Errors due to instruments	97
12.3	Human errors	98
12.4	Rounding off	100
	Chapter 12 : Questions	102
13	NATURAL CONSTRAINTS ON FARMING	103
13.1	Climate	103
13.2	Characteristics of the soil	104
13.3	Soil erosion	107
	Chapter 13 : Questions	108
14	FARMING PRACTICES	109
14.1	Land preparation	109
14.2	Sowing	112
14.3	Crop maintenance	113
14.4	Application of fertilizer	114
14.5	Crop protection	116

14.6	Cropping pattern	117
14.7	Crop rotation	118
	Chapter 14 : Questions	120
15	AGRICULTURAL ECONOMICS	121
15.1	Introduction	121
15.2	Some terms used in agricultural economics	121
15.3	Costs and investments	122
15.4	Costs in cash and in kind	123
15.5	Direct and indirect costs	124
15.6	Credit costs	124
15.7	Cost of investments	127
15.8	Labour unit	128
	Chapter 15 : Questions	130
16	NET PROFIT FROM CROP CULTIVATION	132
16.1	Gross margin of a crop	132
16.2	Gross margin per hectare	136
16.3	Gross margin per man-day	137
16.4	Gross margin per unit of cost	138
16.5	Gross production value	138
16.6	Net profit from crop cultivation	139
	Chapter 16 : Questions	142
17	OTHER HOUSEHOLD INCOME	144
17.1	Net profit from livestock	144
17.2	Net profit from trade and other activities	148
	Chapter 17 : Questions	153
18	CONSTRAINTS ON CHANGES IN FARMING PRACTICES	154
18.1	Physical environment	154
18.2	Technical feasibility	155
18.3	Economic return	155
18.4	Social acceptability	156
18.5	Conclusions	157
	Chapter 18 : Questions	158

ANSWERS TO THE QUESTIONS	159
Chapter 6	159
Chapter 7	159
Chapter 8	160
Chapter 9	160
Chapter 10	160
Chapter 11	160
Chapter 12	161
Chapter 15	161
Chapter 16	161
Chapter 17	162

1.1 Purpose of this book

We have written this book for enumerators who will be trained to work in farm surveys. Their work will be to collect information from farmers about how they farm and about the results they achieve. The book presents basic background information on farm surveys, mathematics, farm management, and farming practices - matters that an enumerator should understand if he is to do his job properly.

The purpose of this book is to show enumerators why they are asked to gather information, how it will be used, and how the quality of their work affects the results of the farm surveys. Enumerators who understand the reasons for the surveys are more likely to be accurate and thorough in their job, and will keep on working steadily and carefully over a long period of time. They will also be better able to explain their work to the farmers and encourage the farmers to cooperate.

1.2 Background of the book

This book describes the work of enumerators among small farmers in semi-arid West Africa. This is an area with one rainy season lasting from four to eight months. The total rainfall is between 400 mm and 1,200 mm, so rain-fed farming (farming depending only on rainfall) is possible. Irrigation (bringing water to the crops) cannot be practised because

water is not available in large quantities.

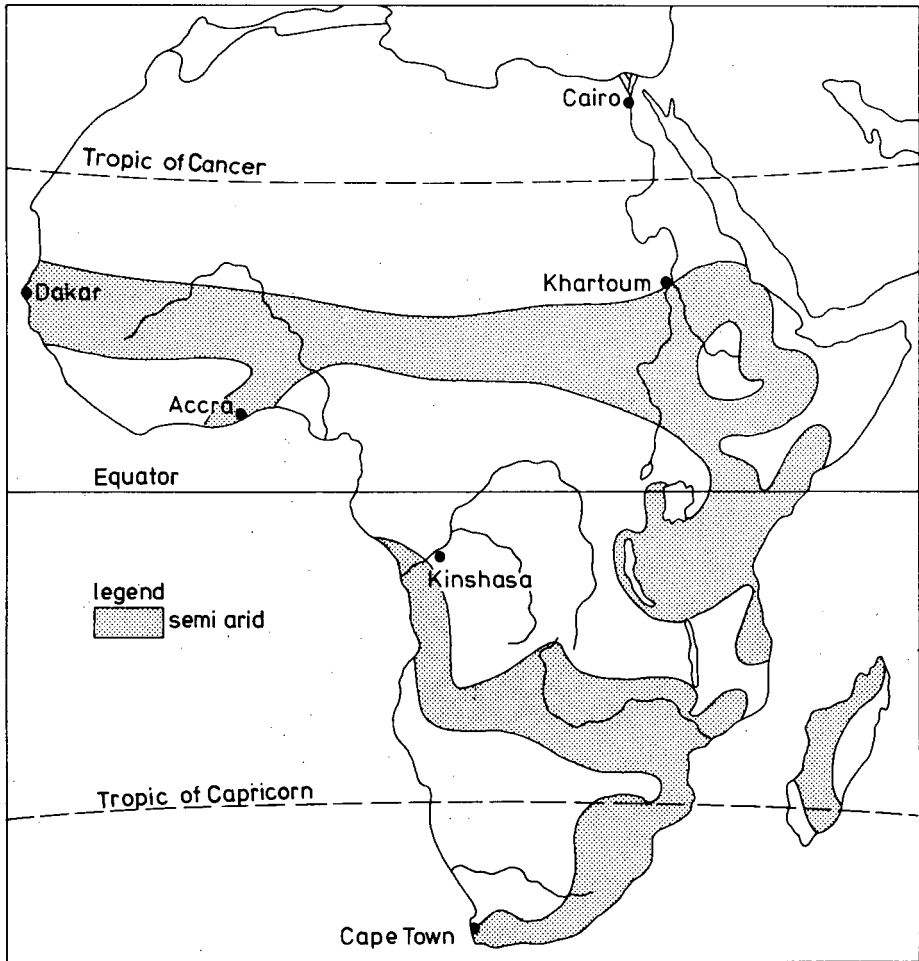

Rainfall in Africa

Most farms in semi-arid West Africa are family farms, with the farmer and the members of his household working together to produce food crops. The household consumes most of the production itself. The small part remaining is sold to pay taxes and cover other cash expenditures. This type of farming is called subsistence farming.

Most of the land cultivated is used to grow food for the household's own consumption; only small areas are used to grow crops which can be sold.

If a crop is cultivated to be sold, it is called a cash crop. Examples are cotton and peanuts.

Because there are great differences in the amount and timing of the rains from year to year, the quantity of crops harvested varies greatly. Sometimes in bad years, some households do not produce enough food to feed themselves. Even in good years, the surplus is likely to be small.

Traditionally, subsistence farmers plough their land with hand tools, sow local varieties of seeds, and apply little or no fertilizer to their crops. They sometimes use animal traction (a donkey or an ox).

In this kind of traditional farming, farmers grow the same type of crop on the same field for many years. When the land is exhausted and the harvest becomes very small, the field is left fallow. This means that it is abandoned to the natural vegetation. After some years, it can be cultivated again.

This system of farming works well as long as populations remain small and land remains plentiful. In many parts of semi-arid West Africa, however, populations nowadays are large and unoccupied land is scarce.

Chapter 1 : Questions

(All pertaining to the area you are working in):

- I. In what period of the year do the rains fall?

- II. About how much rain falls:
In a normal year?
In a wet year?
In a dry year?
How much rain fell last year?

- III. In a normal year, do the farmers produce enough food for their households?
What about the country as a whole; can it produce enough food for its people?

- IV. Can a farmer acquire more land if he needs it?

- V. How many years in a row do the farmers cultivate the same field before putting it in fallow (if a fallow period exists)?

2.1 The need for information

It is vital that farmers increase their food production. Populations are growing and everywhere there is a demand for more food. If farmers can grow more food than they need for their households, they can sell the surplus. Large surpluses can even be sold to other countries.

A country can increase its food production in two ways: it can farm more land and it can get bigger harvests from the land already being farmed. Throughout the world, agronomists are developing new, higher-yielding varieties of seed, and everywhere farmers are being encouraged to use new farming techniques that give better results than their traditional farming practices do.

The new farming techniques include the protection of plants from diseases and pests, the conservation of the soil, the use of animal traction, and the use of manure and chemical fertilizers. These techniques are usually developed and tested at agricultural research stations, where 'farming' conditions are very good. At a research station, all the 'farming' operations are technically correct and they can all be done at the proper time. Money and labour are in relatively plentiful supply at a research station. It is therefore difficult to be sure whether the techniques developed there will be as good when they are used by a real farmer.

In real life, farmers cultivate a fairly large area with only a small number of workers (the members of their households). They have many social obligations to fulfil and need to go to the market or to visit relatives once in a while; they cannot spend all their time farming. Sometimes, they cannot sow all their crops at the proper time; other times they will weed some crops poorly or too late; often, they will not have much money to spend on fertilizer, so they use only small quantities, if any at all.



Farmer applying fertilizer

Even if a farmer is using new farming techniques, all these elements will influence the results he really achieves. In some cases, if he does not fulfil a set of minimum requirements - like applying a minimum amount of fertilizer or doing a minimum amount of weeding - the new farming techniques may cost him more money than they are worth, because they do not pay off in bigger harvests.

Whether farmers are following traditional techniques or applying new ones, the agronomists working at research stations need to know the results really being achieved by the farmers. If they have this in-

formation, they can modify and adapt the new farming techniques and make them more suitable to the farmers' real conditions.

The people who organize programs of agricultural extension also need to know what the farmers are achieving. If they know this, they can see whether their programs are really helping the farmers; if not, they can decide what changes they should make in their future programs.

Theoretically, if an agronomist or the head of an extension service wants to know about the results being achieved by farmers, he could go to their villages and talk to them himself. But this would take up a great deal of his time and would probably conflict with the rest of his work. Besides, he would not be able to talk to enough farmers or to visit enough villages. So, instead, a farm survey is conducted.

In a farm survey, information is obtained from a great many farmers. The persons who obtain this information are called enumerators. The information they collect is then passed on to agronomists or to the heads of extension services.

Farm surveys focus not only on agriculture; they also cover aspects of the social life in the villages, because these greatly influence the changes that the farmers are willing to make in their farming practices.

For example: If it is known that the farmers spend only 60 per cent of their days on farming during the rainy season, one cannot automatically conclude that more labour-intensive farming practices could be introduced. It is quite possible that the farmers spend the remaining 40 per cent of their days on social activities that they consider more important than a bigger harvest!

Ideally, enumerators begin gathering data while farmers are still farming in the traditional way. The agronomists can then find out how to make this way of farming more efficient. They can then recommend an agricultural extension program that is well adapted to the needs of the farmers.

For example: If the agricultural extension office wants to introduce a cash crop in a region, it first needs to know whether the farmers are already producing enough food for themselves, and are therefore able to reserve part of their land to grow cash crops on. If not, the extension program can far better start helping the farmers to grow more food before considering the introduction of cash crops.

Farm surveys are also very useful during the course of extension programs; they can show whether the farmers are applying the recommended techniques and, if not, why not. The surveys can also reveal whether the farmers who *are* applying the new techniques are obtaining the results that were expected.

2.2 The role of a monitoring and evaluation unit

The managers of large development projects often decide to employ enumerators on a permanent basis. The enumerators then work in the project in a special unit which organizes and coordinates the farm surveys. This unit may be called a 'Statistical Unit' or a 'Monitoring and Evaluation Unit'. Monitoring means that the staff of the unit continuously observe the activities of the farmers; evaluation means that these observations are analyzed and studied.

A monitoring and evaluation unit can be attached directly to the general management of a project, or it can be part of an extension service or an economic planning service. The unit will receive requests for information from various specialists who need this information for their work. The director of the unit then combines these requests and designs a program of farm surveys to collect the information that has been requested.

The director of a monitoring and evaluation unit is usually an agricultural economist. He organizes the surveys, supervises the work of his staff, and presents the results in reports. The staff includes enumerators (who collect the information) and data processors (who group and tabulate the information collected by the enumerators). The unit may

also have its own secretary, although in most cases it may have to share a secretary with others in the project.

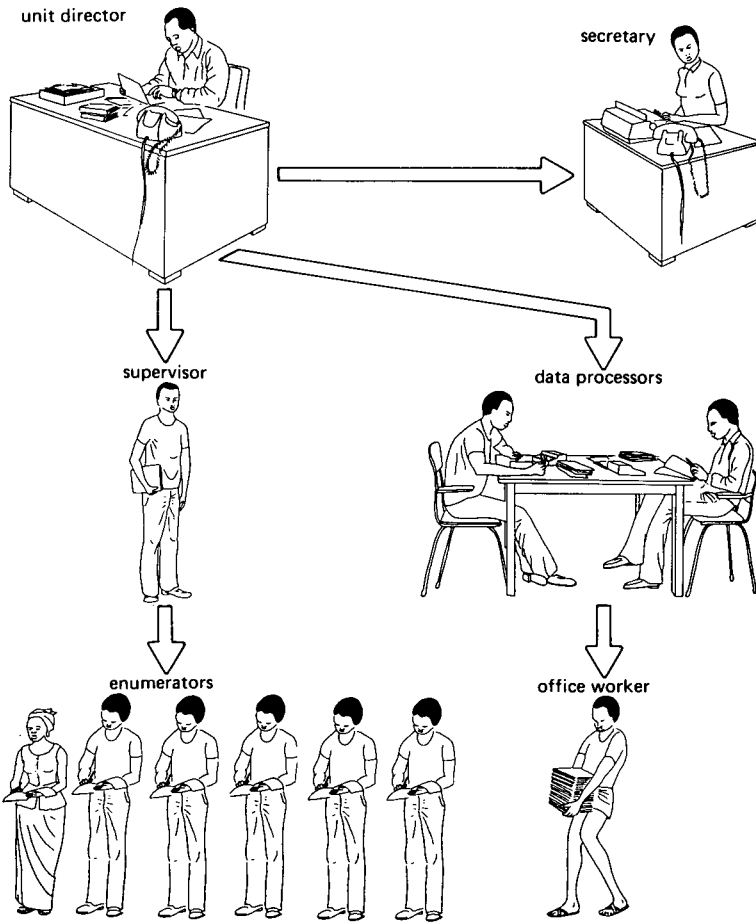

Staff of a monitoring and evaluation unit

If a unit has many enumerators, it will also have a number of supervisors who assist the director in the field. Each supervisor is responsible for a group of enumerators. He guides them in their work and sees to it that they receive the necessary equipment to do their job. The supervisors report regularly to the director on how the work is going in the field.

When a survey is to be conducted, the director of the unit consults with

the people who are requesting information. Together, they define the precise objectives of the survey; this means that they define precisely what information is to be collected. The director then decides how it will be collected and prepares the survey forms which the enumerators will use to write down the information they collect.

The director will also consult with the enumerators while he is preparing the surveys. This will be discussed in Chapter 5.

2.3 The role of the enumerator

Each enumerator should understand that the quality of his work greatly affects the results that his unit is capable of producing. The results of a survey will be useful only if the information that is collected is valid. This means that it must be accurate and complete, and that it must be collected at the proper time.

The work of an enumerator consists of three elements:

- He has to conduct interviews and make observations as instructed, and has to note the farmers' answers and his own observations accurately;
- He has to behave in such a way that the farmers feel at ease with him and are willing to tell him the truth;
- He is constantly observing and comparing his observations, so that he notices if a farmer is forgetful or not entirely truthful, and so that he can report to the unit's office any unusual situation which helps explain the information he has collected.

All the efforts of enumerators are wasted if the farmers are not willing to cooperate. The fact that the farmers readily answer questions does not mean that they are telling the truth; they may just be trying to get rid of the enumerator. It is therefore important that the farmers understand from the start what the purpose of the survey is, what they will be asked to do, and what the results will be used for.

Chapter 2 : Questions

(All pertaining to the area you are working in):

- I. Describe the farming practices of the farmers in your area.
- II. What new farming techniques are being introduced in your area?
- III. Can you think of any aspects of traditional life that might make the farmers reluctant to adopt (new) techniques such as:
 - Animal traction?
 - Improved seed varieties?
 - Cash crops?
 - The use of fertilizer and insecticides?
 - More labour-intensive farming practices?

Before a survey can begin - while it is in its preparatory phase - the director of the unit will contact the proper authorities within the administration and within the traditional hierarchy. He will then explain to them the reasons for the survey. The attitude of the authorities towards the survey will influence the attitude of the farmers, so care must be taken not to antagonize the authorities when introducing the survey. If they understand the reasons for the survey and are in favour of it, they can provide valuable information about the history and the infrastructure of the area. They can also supply useful information about the villages that might be selected for the survey.

The procedure for introducing the survey to farmers in the villages depends partly upon local customs, and especially upon the influence of the traditional chief. He is an important man and his behaviour towards the director and other members of the unit's staff will greatly influence the behaviour of the farmers, so it is vital to gain his cooperation.

Whatever procedure is followed, it is important to keep everything out in the open. Acting in this way will help to prevent the spread of rumours (that the information to be collected will be used for tax purposes or that the farmers who will take part in the survey have been selected for special treatment).

The survey should be introduced to the farmers in two stages: first, to

all the farmers in a village, and second, individually to each of the farmers who will take part in the survey.

3.1 Village meeting

After explaining the survey to the traditional chief, the director of the unit will ask him to call a meeting of the villagers. During this meeting, the chief will announce the survey and will introduce the director, the enumerator who will work in the village, and the enumerator's supervisor, if any. This will show that the chief is informed about the survey and agrees with the need for it.

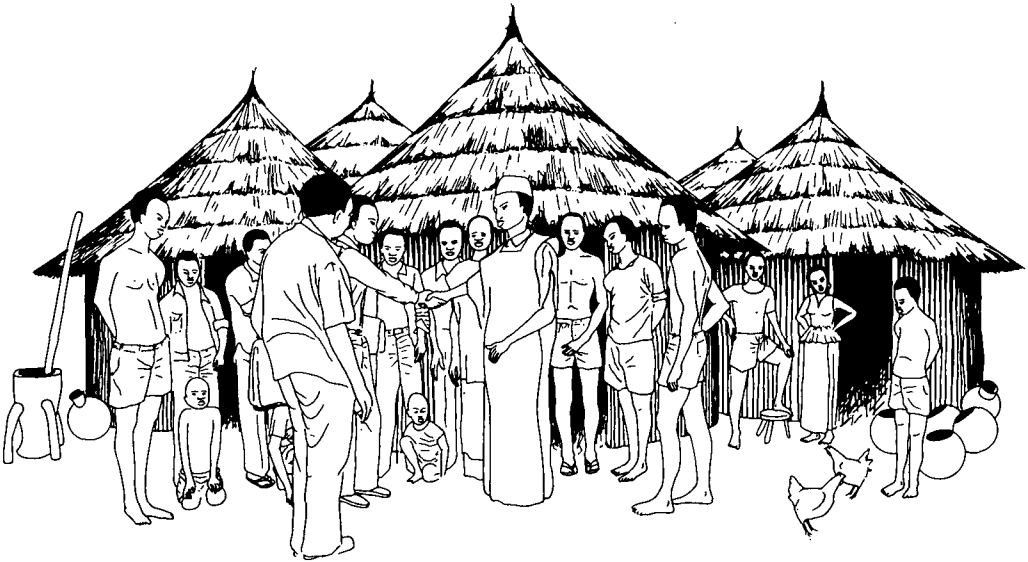

The traditional chief welcomes the director and the enumerator to the village meeting

The director should then explain in simple terms which agency they are working for and what the objectives of the survey are. These objectives should be presented in general terms.

For example: We want to find out if the project is really achieving the results that were expected.

Or: We want to find out the best way to grow peanuts in this area.

Immediately after that explanation, the director should describe the steps involved in the surveys in very concrete terms.

For example: We will measure all the crops at harvest time right in each farmer's compound and we will not take anything away.

Or: We will note, step by step, how the farmers here grow their peanuts and then measure the harvest so that we can all understand which is the best way to grow peanuts.

This explanation should be quite detailed, emphasizing especially the physical handling of the crops when harvest estimates are being made.

During the meeting, the farmers should be informed about the work of the enumerator so that they will know what to expect.

For example: The farmers should be told where the enumerator will live, how often he will visit the farmers' compounds, that he will observe their work in the fields, that he will write down his observations and the information given to him by the farmers on forms which he will later send to the unit's office.

It should be emphasized at the meeting that those forms will be sent to the office so that the results can be calculated and compared with those of other farmers, but that the forms will not be given to the government for tax purposes or for any other reason.

At that stage, it is easy to explain that it would be impossible for the enumerator to do this work with all the farmers, and that therefore a group of farmers will be chosen to represent the village. It is important to insist that the farmers who will be selected are neither better nor worse than the others, and that they will be neither punished nor particularly rewarded for taking part in the survey.

Whenever possible, the farmers who will take part should be selected at the meeting. One way to do this is to write the names of all the farmers

on small pieces of paper, put these papers into a hat, and ask the traditional chief to take out the required number of papers. Selecting the farmers in this way - out in the open in front of everyone - will make it clear that the selection was not arranged beforehand. The group of farmers so chosen is known as the 'sample'.

3.2 Visiting the farmers in the sample

The next stage in introducing the survey is that the enumerator and the director (or the enumerator's supervisor, as the case may be) locate the homesteads of the farmers in the sample and visit each of them individually. The main reasons for this visit are to introduce the enumerator personally to the farmer and the members of his household, to explain to them the work involved in the survey, and to answer any questions the farmer might have been hesitant to ask in front of his neighbours at the village meeting.

During the visit, the farmer will once again need to be reassured that his participation in the survey will not create difficulties for him with taxes or with agricultural credit, and that the local authorities know about the survey and are favourable towards it.

The enumerator should be aware that farmers are often genuinely interested in finding out how much food they produce and what their incomes really are (measured in more official units of measurement than the local ones). He should also realize that the farmers are more likely to be truthful in their answers to his questions if they know they will be kept informed of the findings of the survey while it is in progress.

The farmers, on their part, should be made aware that if they give inaccurate or incomplete information, they are putting the entire work of the unit in jeopardy. (In areas with food-aid programs, farmers may systematically under-report their crop yields, hoping for more food aid.)

The first visit to a farmer is very important because it lays the basis

for cooperation between the enumerator and the farmer - cooperation which is essential to the success of the survey.



Visiting a farmer at his compound

At the beginning of a survey, it may happen that a farmer selected in the sample refuses to take part in the survey and cannot be persuaded to do so. It may also happen that one of the farmers selected plans to migrate shortly afterwards. In such cases, other farmers can be chosen to take their places. This will not hurt the survey in any way. It is far more detrimental, however, if a farmer has to be replaced half-way through the crop season, because the 'new' farmer will find it difficult to remember details of what he did early in the season. The enumerator should therefore do everything he can to avoid 'losing' a farmer during the crop season.

After the village meeting has been held and the individual visits have been made, it is polite for the enumerator to visit the traditional chief again to thank him and to inform him of any farmers who have been replaced in the sample.

3.3 Building up a good relationship with the farmers

The behaviour of the enumerator towards the farmers is crucial to the success of the survey, whether he lives among the farmers during a long-term survey or whether he only comes to the village for short visits. The farmers do not need the enumerator; *it is the other way around!* An enumerator who comes to a village and starts bossing people around to come for interviews is not going to obtain data that are worth processing. An enumerator who is polite but seems in a hurry and just writes down what the farmer says without thinking about it is not going to get good data either.

The first task of the enumerator is to make himself accepted by the people in the village. This means behaving politely. The enumerator is a stranger and should behave accordingly, going to greet the traditional chief and the authorities according to custom, and always being polite to everyone. He should also take the time to explain to the villagers who he is and what work he is there to do. His own director (or supervisor) has already introduced him to the authorities and explained the objectives of the survey, but even so, it is likely that further explanations will be needed. The enumerator should always be willing to answer questions about the survey from the authorities and the villagers.

Sometimes in the villages, there may be conflicts between families or between neighbourhoods or groups. The enumerator must be very careful not to let himself get involved in these conflicts. When he first arrives in a village, it is easy for him to become involved without even knowing it, simply by accepting an invitation to rent a room in a homestead or a *case* in a compound, or even by talking often with someone who is very friendly, not knowing that this person may be disliked in the village. Until the enumerator has had time to find out what the situation in the village is, it is best for him not to become too clearly associated with anyone.

If the enumerator lives in the village, he should be aware that his

behaviour and way of life are going to be observed by the villagers, so he must obey the usual rules for strangers to the village and take care that his visits to the various homesteads can never be misinterpreted. (This is especially important if he is not married.) He should dress in a manner appropriate to going into the field; formal city dress is not practical for field work.

Even after the enumerator is well accepted in the village, his behaviour during each interview remains important. If a farmer is upset because the enumerator interrupts the farmer's work or rushes through the salutations, the farmer may give only minimal answers to his questions. The enumerator should be particularly careful not to gossip about the families he surveys, and never to repeat any private and personal information which the farmers entrusted him with in the course of his work. That could cause him to lose the trust of the farmers and may even force him to leave the village. Any questionable attitude towards the women of the village could have the same result.

Enumerators should realize that a vital part of their work is gaining - and keeping - the trust of the farmers.

Chapter 3 : Questions

- I. If you had to introduce a survey in your village, which persons would you approach before starting the survey?

- II. a) In your village, have you noticed any conflicts between groups or between families?
If so, what are the underlying causes of those conflicts?
b) Suppose an enumerator goes to a village to do a survey.
What tips could you give him so that he has a better chance of keeping out of conflicts?

- III. Suppose a farm survey is to be done in your village. The survey will investigate what results the farmers are achieving in their fields, how much it costs them to cultivate their crops, and what income they earn from activities other than farming.
a) Do you think there might be some matters on which the farmers may not want to cooperate? If so, what are these matters?
b) How do you think this cooperation could be obtained?
c) What would you do to keep the farmers' cooperation in a survey that lasts several years?

4.1 Observations and interviews

The data that an enumerator will be required to gather during a survey can be obtained in two different ways:

- By observing what is going on in the fields;
- By interviewing the farmers.

For example: After animal traction has been introduced in an area, the extension service will want to know whether the farmers are indeed using animal traction to plough their fields. An enumerator can be sent to observe the farmers during ploughing to see whether they plough by hand or with animal traction. This is data-gathering by observation.

The enumerator can also be requested to go to the farmers and ask them whether they are using animal traction or not. This is data-gathering by interviews.

If the farmers tell the truth, it is much easier and takes less time to ask them - even months after the event - than to follow them about to see what they do. Besides, many events are too complex to be studied by observation, or the survey would become too expensive because it would require too many enumerators. An enumerator can handle only a limited number of events.

For example: Labour-time studies by observation could only be done if

each enumerator followed one or two families at the most, or observed only a few fields located near one another.



Enumerator observing the development of a crop

Information obtained by interviewing is likely to be less accurate than that obtained by observation because the farmers may not remember or do not wish to tell. On the other hand, the quantity of information that an enumerator can gather by interviews is much greater; so interviewing is much cheaper per item of information obtained. In practice, it is common to combine interviews and observations. In this way, accurate data are obtained (by observations) and at low cost (by interviews).

For example: If one wants to know how much of their crop the farmers in a village sell at the local market or elsewhere, one could observe them to see what they do. That would be very expensive because many enumerators would be needed. It is much easier to visit each farmer regularly and ask him whether he has sold part of his crop, even though he might not always tell the truth. A combination of regular interviews and regular visits to the local market makes it possible to check part of the information obtained from the farmers. A farmer who says he did not sell anything although he was seen at the market

selling a crop might be telling the truth; perhaps he was selling it for a friend. The enumerator should inquire carefully whether it was the farmer's own crop that he was selling or someone else's. This survey thus combines interviewing the farmer with direct observations at the market.

4.2 Single and repeated interviews and observations

If a survey covers an event that has passed and that happened only once, it is enough to interview each farmer once only (e.g. asking him about his harvest of the past year). One interview is also enough if the purpose of the survey is to find out about a situation at a certain point in time.

For example: Suppose data are required about the number of people in the household, the type of crop being cultivated, and the tools that are being used to cultivate the crop. A farmer can provide all that information for one crop season in one interview.

If the purpose of the survey is to study activities that are taking place over time, the interviews have to be repeated at regular intervals.

For example: If the trading activities of a member of the household are to be studied throughout the year, the trader will be asked questions every one or two weeks, depending on how much trading he or she does.

With some activities that take place over time, the survey may only require information about the end results of that activity. If so, one interview just after the activity has been completed will suffice.

For example: The costs and benefits of cotton growing are to be studied in a region. It is known that in that region cotton is grown by household labour only and that the entire cotton crop is sold to

the government marketing board. Here, it is appropriate to interview the farmer just after the sale of his cotton. He will easily remember how much it cost him to grow the cotton crop because the few inputs he had to buy are relatively expensive. And he will have no trouble remembering how much money he received from the marketing board.

If the survey requires detailed information which the farmer cannot possibly remember for a long time, he will have to be interviewed often.

For example: If information is required about the work done by each member of the household or about the quantities harvested day by day, the farmer will have to be interviewed often because he cannot be expected to remember those things for more than a few days. This is in contrast to many other activities such as selling a sheep or applying fertilizer, which will be remembered clearly for several weeks.

In a survey with frequent repeated interviews, it is usually arranged that the enumerator lives in the village of the farmers he will visit. This enables him to obtain more detailed and more precise information than if he lived somewhere else and only visited the farmers now and again.

Living in the village also makes it easy for the enumerator to visit the fields to make observations. These may be either single observations (e.g. to see what type of crop is being grown on a certain field) or repeated observations (e.g. to see how a crop is developing).

4.3 Open-ended and multiple-choice questions

An enumerator can obtain information from a farmer by conversing with him, just as two neighbours will do. In this way, however, he might not obtain all the information he wants because, in a conversation, he is likely to forget some of the topics that he should talk about. Besides, later at the office, the data processors have to tabulate together the information obtained by all the enumerators. This would be impossible

for them to do if each enumerator has a different conversation with each farmer.

For these reasons, the questions that the enumerators will ask should be written down in advance. These questions can be presented to the farmer in two different ways:

- As open-ended questions;
- As multiple-choice questions.

Open-ended questions are printed on the survey form and are read to the farmer exactly as they are written and his answer is copied on the form exactly as he says it. Open-ended questions make a survey rather time-consuming, so they are only practical for a single-visit survey or a reconnaissance survey. (A reconnaissance survey obtains basic information on which a more in-depth, long-term survey will be designed.)

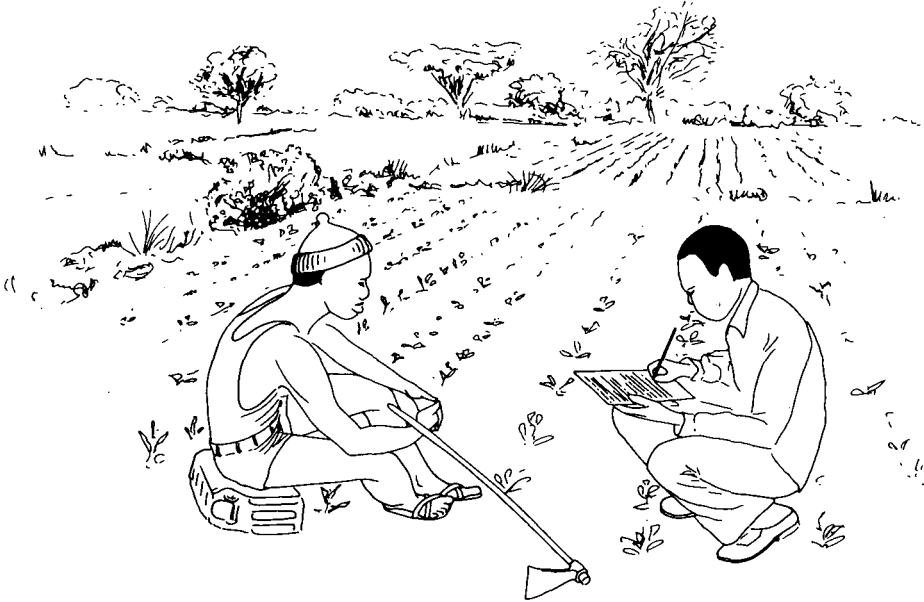

Interviews are held wherever convenient for the farmer

With multiple-choice questions, the questions are printed on the survey form, along with a list of their possible answers. The enumerator reads

a question to the farmer, who answers in his own words, and the enumerator marks on the form the answer that best covers what the farmer has said. The enumerator can also read the question and its list of possible answers and have the farmer choose the right answer, which the enumerator then encircles or marks with a cross.

Example of a multiple-choice question

Which of the following cereals did you grow this year? (Mark the correct answer with a cross.)

1. White sorghum
2. Red sorghum
3. Millet
4. Maize
5. Rice
6. Others

Note that multiple-choice questions should always have an answer 'Others' so that any unusual answer can be written down.

Multiple-choice questions have several advantages: they help the farmer remember things he might not think of mentioning himself, and they are easy for the data processors to read, check, and tabulate.

In a long-term survey, open-ended questions could be used in the first period. Then, afterwards, the information they provide could be used to compile multiple-choice questions and their lists of possible answers.

4.4 The wording of questions

The farmer should only be asked questions that he is able and willing to answer. The questions should be worded in such a way that they are easy for him to understand and simple for him to answer; the questions must be clear. Also, the questions should not upset him or influence his

answer; the questions must be neutral.

A question should not mention units that a farmer does not understand. He will then not be able to answer even if he wants to.

For example: If a farmer is asked: 'How many days does it take you to plough a hectare?', he cannot answer if he does not know how much land a hectare represents.

It is also possible that a farmer does not want to answer a certain question.

For example: If he is asked: 'How much money did you spend to buy dresses for your first wife?', he may know the answer but does not want to tell it because he considers the matter too private.

These examples are very obvious, of course, but all questions should be looked at to see whether the farmers can answer them truthfully and are willing to do so.

Each question should be worded in such a way that it is clearly understood by both the enumerator and the farmer, with no possible misunderstanding about its meaning. This is quite difficult to do because what seems clear to one person is not always clear to another. Sometimes a question is too broad or too complex; it is, in fact, several questions in one, and the farmer will not know how to answer. Before the questions are finally printed on the survey forms, therefore, it is a good idea to ask several people, including some farmers, what they think each question means.

Some very common words, such as 'family' or 'field', have more than one meaning, so it should be explained clearly which meaning is used in the question.

For example: A question about a farmer's 'family' could mean all those people with whom he has blood or marriage ties, or it could mean his wives and children only.

The way in which a question is worded should not influence the farmer's answer. He should never feel that one answer is better than another, or that his answer could get him into trouble or could displease the enumerator. The enumerator should never show that he thinks the farmer has done something wrong.

For example: If the farmer is asked: 'Did you use fertilizer as the extension agent told you to do?', he will feel that it is safer for him to answer 'Yes', even if it is not true.

Chapter 4 : Questions

I. A monitoring and evaluation unit has been created in a project to gather and analyze data about the following topics:

- Rainfall;
- Rotation of crops;
- Cost of crop cultivation;
- Labour input;
- Crop performance;
- Use of animal traction;
- Market prices of crops;
- Income from off-farm activities.

- a) On what topics would you recommend that data be gathered by observations?
- b) On what topics would you recommend that data be gathered by interviews?
- c) On which topics would you recommend repeated interviews or observations?

Explain your answers.

II. What do you think is wrong with the following questions?

- a) Did you protect your seeds against insects correctly, using the prescribed chemical?
- b) What is the date of birth of each member of your family?
- c) Do you have draught animals and equipment and do you use them to farm your land?

5.1 The survey forms

Before the start of the survey, the director will make a list of the data that are to be gathered by the enumerators. He then decides which data will be obtained through interviews and which by observations. Next he prepares the survey forms that will be used by the enumerators to write down the data they collect. These forms are also called questionnaires. They should be prepared very carefully because they have a great influence on the accuracy of the data gathered and also on the accuracy of the tabulations made at the office afterwards.

To prepare the forms, the director first makes a list of all the questions that will be asked and all the observations that will be made. He decides how often the farmers will be interviewed and how often the observations will be made. He then groups the questions into categories, decides which categories can be presented on the same survey form, and prepares a first draft of each form.

Examples of survey forms

There may be a form for data on the household (age and sex of the people living in it and the type of work they do). This form can be filled in during the first visit to the farmer.

There may be another form for the agronomic data on each crop (sowing time, fertilizer used, quantity harvested, etc.). Data will be entered on this form throughout the crop season.

Yet another form may be for data on livestock and the income obtained from it. Data will be entered on this form once a week throughout the year.

In a long-term survey, it can be useful to group the questions on one topic into a table, which the enumerator simply fills in during each interview.

For example: Table 5.1 is a table grouping questions about livestock. Using this table, the enumerator visits a farmer once every week to inquire about the farmer's livestock activities. After the usual greetings and informal talk, the enumerator sits down and first writes the date of that day in the first column on the left. He then asks the farmer if he has bought any livestock since the last interview. Suppose the farmer says: 'No, I have not'. The enumerator writes on the line next to the date: 'None' or some other word to indicate that no livestock has been bought. The next week he comes back to the same farmer and asks the same question. Now the farmer says he bought a goat for 2,000 CFA from his neighbour who needed cash at that time so he got the goat quite cheaply. Table 5.1 shows how this information is recorded.

At the end of the month the totals are calculated and discussed with the farmer. The form is then sent back to the office and the enumerator starts a new form, or he continues on the same form for the next month.

Of course, this is only part of a livestock survey; other questions will be asked at the same time about sales of livestock and cost of upkeep of the herd.

The first draft of the set of survey forms is made by the unit director at the office. He then discusses the forms with the enumerators. This

Table 5.1. Example form for livestock purchases

Date interview	Oxen		Cows		Sheep		Goats		Poultry		Other		Where obtained						
	Num- ber	Price (CFA)	Num- ber	Price (CFA)	Num- ber	Price (CFA)	Num- ber	Price (CFA)	Num- ber	Price (CFA)	Num- ber	Price (CFA)	Local market	Town market	Neigh- bour	Birth	Gift	Paid back	Other
July 9	n o t h i n g																		
July 16							1	2,000											x
Total													Grand Total (CFA)						
Observations: Goat July 16 very cheap because neighbour needed cash																			

discussion will be most useful if the enumerators have been living in the villages for a while and so know the farmers and their habits. The matters to be discussed are whether the questions are clear and neutral and whether they are properly worded, how they are presented on the forms, how often the forms will be filled in, and which forms can be filled in during one and the same visit.

For example: Sometimes the enumerator can fill in several short forms at one time, asking the farmer about work done in the field and about livestock activities.

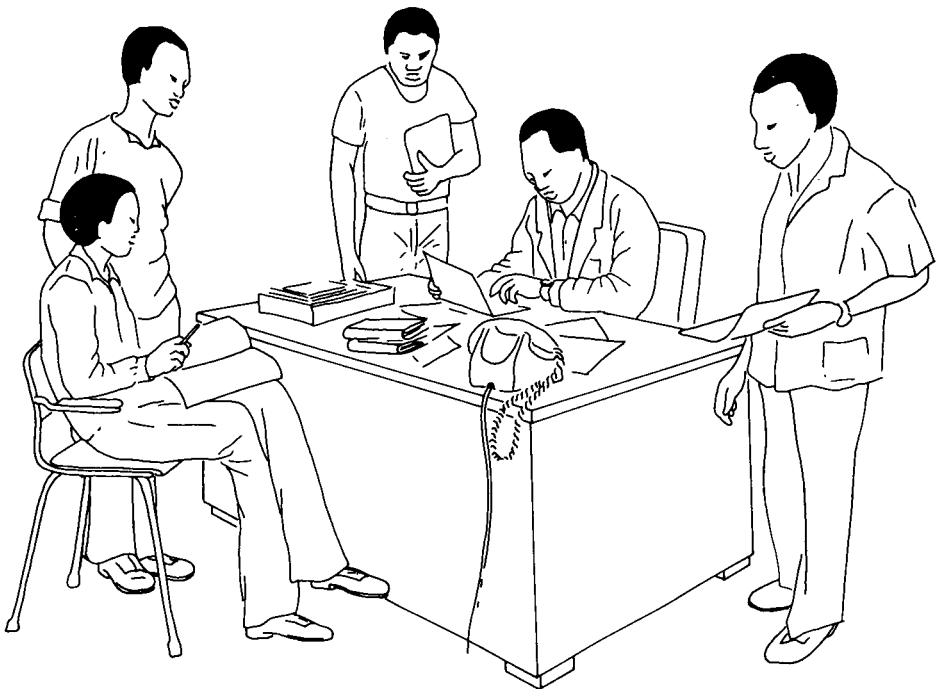

Director and enumerators discussing the survey forms

After the discussion, the director will compile the second draft of the forms and will decide what program the enumerators should follow so that the interviews and observations are done regularly and in the same way by everyone.

The programs and the forms should then be tested in the field. The

enumerators follow the prescribed program and use the forms to interview a few farmers. After a couple of weeks, the director calls another meeting to discuss with the enumerators any problems encountered with the program or the forms. The director will then draw up the final program and the final set of forms. Both program and forms should then remain unchanged for the entire crop season.

5.2 An 'Enumerator's Manual'

To do a good job, an enumerator needs to understand the objectives of the surveys and why the results are needed; he can observe well only if he knows what to look for. At the beginning of a survey, the director will explain these objectives to the enumerators, and will inform them on such matters as what their work schedules will be, how they should fill in the survey forms, and how they should handle any unusual situations. As an aid to memory, he may provide them with an 'Enumerator's Manual', a document that contains all this information. Such manuals, intended to guide the enumerators in their work, are especially written for each survey program. Enumerators should study their manuals carefully and use them as a reference whenever they are not sure how to record an answer.

5.3 A regular schedule of interviews

It is important to set up a regular schedule of interviews with the farmers so that they will know when to expect a visit from the enumerator. If there is a delay, a farmer is more likely to forget some information or to make a mistake. Besides, it is always a problem for an enumerator to catch up with one farmer without delaying his other interviews too.

Delays will be kept to a minimum if the enumerator has a good relationship with the farmer, who will then keep the enumerator informed of his travel plans and will make an effort to be at home at the time agreed on for the interview.

Sometimes, delays in interviews cannot be avoided. Perhaps the date set for the interview coincides with a religious holiday or the farmer is ill. If the enumerator has established a good relationship with the farmers, however, he will be kept informed of events (trips, ceremonies, illnesses) and can rearrange his schedule accordingly.

5.4 Recording understandable data

When filling in the survey forms, the enumerator should constantly ask himself: 'Will the people at the office be able to understand what I write down?' This means they must be able to read it (so his writing must be clear and legible) and they must be able to understand it (they must be able to make sense of it). Many times, simply noting the farmers' answers is not enough. The answers are not fully understandable because the situation which caused them is not explained. For this reason, most forms provide space for comments, in which any unusual answers can be explained.

Even the most carefully designed survey forms cannot foresee all the circumstances that might affect the data. If the enumerator obtains an important item of information for which there is no space on the form, he should make a note of it in his observation notebook. During the next visit of his director or supervisor, he should bring up the matter and will be advised how to handle it.

5.5 Visiting the fields

The enumerator will usually be asked to go regularly to the fields of the farmers he is surveying and observe certain things. To do this work correctly, he must visit *all* those fields, not just those close to the road or otherwise easy to get to. In the fields, the kinds of things he will be asked to observe are:

- Can the crop be expected to yield much or not?
- Is the crop damaged by diseases, insects, or animals?

- Is the field weeded properly?

Observations of this kind will help to explain differences in yields obtained by the farmers, or may show that errors were made when data were being gathered.

For example: A crop that looks poor or is damaged cannot be expected to give a good yield; but if a crop that looked good gives a poor yield, the data need to be checked to explain why this is so or to find out whether any errors were made.

Visits to the fields provide useful additional information which helps to explain any unusual results.

For example: If a crop is half destroyed by fire before harvest, this fact should be noted as it will explain the surprisingly low yield of that field.

Field visits are also a simple way of checking the data provided by the farmers.

For example: If a farmer says he spent three days last week weeding and the enumerator sees that the field is indeed properly weeded, he will know that the farmer is telling the truth.

When the director or supervisor comes to the villages on his regular visits, he will be checking the survey forms for any unusual data (very high or very low yields or an exceptionally large area put under cultivation). If the enumerator has been careful in his work, he will already have noticed these unusual cases and will have inquired about possible explanations for them. In this way, he can show the director that the unusual data were not due to any mistake on his part.

The enumerator's visits to the fields are an important part of his work. Not only are these visits useful for the survey, they also show the farmers that the enumerator is really interested in their farms and this helps to improve the enumerator's relationship with the farmers.

5.6 Surveys of long duration

Some surveys are done repeatedly over a long period of time. It can become very boring asking the same questions over and over again, filling in the same forms time after time, and constantly performing the same checks on the answers. Yet, enumerators should understand that it is vital for the success of the surveys that they make their inquiries regularly and completely as scheduled, and that they all ask the same questions in the same way each time. Otherwise it will be impossible to make comparisons between farmers and between villages. It is tempting for an enumerator to skip some questions after a while because he thinks he knows what the farmers have been doing. But this is how data on important unusual events can be missed.

In a long-term survey, both the enumerators and the farmers are likely to become bored unless they see some results from their work. If the farmers have been promised data on their crops, the enumerators should give them these data as soon as the data become available. This will ensure the farmers' cooperation for the next crop season. In their turn, the enumerators should be kept informed of all the results put out by the monitoring and evaluation unit.

Chapter 5 : Questions

- I. Suppose you are to prepare a survey program and the survey forms to gather data on handicrafts as a source of income. (Handicrafts are objects made at home to be sold.) The objective of this survey is to identify the types of handicrafts that are made in the area and their importance as a source of income for the household.
 - a) Make a list of the data that are to be gathered.
 - b) For each type of data, indicate how they should be gathered (single or repeated interviews or observations).
 - c) For the data to be gathered by repeated interviews and observations, indicate how frequently these interviews and observations should take place.
 - d) Prepare the survey forms.
 - e) Prepare the enumerator's survey program.
 - f) How would you ensure the long-term cooperation of the farmers?

6.1 Population and sample

A survey is conducted on what is known as a population. A population consists of elements, which can be people, animals, or things. This will be explained by a few examples.

Examples of populations

Suppose the sorghum production in a certain region is to be surveyed. The population then consists of all the sorghum fields in that region. The elements of the population are the individual sorghum fields.

If a study is being made to find the average weight of cows in a certain region, the population consists of all the cows in that region. The elements of the population are the individual cows.

If the study is concerned with the average number of people in the households of a country, the population consists of all the households in that country. The elements are the individual households.

If a population is only small, all its elements can be surveyed and information can be obtained about each of them. If a population is large, it would become too expensive and time-consuming to survey all

its elements. So instead, it is usually decided to select some of the elements and to conduct the survey on them. The elements selected for this purpose are known as a sample of the population.

6.2 A representative sample

A sample is drawn when it is either impossible or unnecessary to survey the entire population. The results of a survey made with a sample are then regarded as being the same as the results that would have been obtained if the entire population had been surveyed. Generalizations made in this way are only valid if the sample has been selected in such a way that it represents the population as closely as possible. Such a sample is called a representative sample.

In practice, it is impossible to select a sample that represents the population perfectly in all its aspects. Nevertheless, in surveys, the sample need only be representative in those aspects that will be studied by the survey.

The first step in selecting a sample is to look at the population. Does it consist of one group only, or can it be divided into subgroups which are significantly different in the aspects to be studied?

For example: Suppose that a population of farmers is to be surveyed. The aspects to be studied are the agricultural incomes being earned by the farmers. It is known that some of the farmers farm in a modern way and that the others farm traditionally. The population can then be divided into two subgroups because the modern farmers can be expected to earn significantly higher incomes than the traditional farmers do.

If it is known that the elements of a population are not significantly different in the aspects to be studied, the population is called homogeneous. When little is known about a population at the start of a survey, it is often considered homogeneous to begin with. Later on, if the need arises, the population can be divided into subgroups.

For example: In a certain region there is still much good land not being cultivated, so every household cultivates as much as it is able to. The households all use the same farming techniques.

After the start of the survey, it is found that some of the households are Moslem and the others are Christian. Moslem householders usually have more than one wife so Moslem households have more workers per household than Christian households do.

If the survey has to find out how much land is being cultivated per worker, the population can be considered homogeneous. All workers, whether they are Moslem or Christian, will cultivate about the same area of land because they all use the same farming techniques.

If the survey has to find out the income that each household earns from agriculture, the population should be divided into two sub-groups: Moslem and Christian households. With more workers per household, the Moslem households can cultivate more land and can therefore earn a higher income than the smaller Christian households can.

If the population is homogeneous, it is possible to draw a sample by choosing 'representative' elements from the population. But this calls for difficult judgements on the part of the person selecting the elements. The following example shows how risky and uncertain such a selection can be.

Suppose that an enumerator has to estimate the yields of the sorghum fields. To do so, he must measure the harvest of a small square sample plot, which he pickets off in a representative part of each field. The enumerator has to decide which part is representative. A pessimistic enumerator will put the sample plot in a place with a lower yield than the average yield of the field; so all his estimates will be systematically too low. An optimistic enumerator will put the sample plot in a good place where the yield will be higher than the average; so all his estimates will be systematically too high. A lazy enumerator will probably put the sample plot at a place easy to

reach, say near the road, which may not provide a correct estimate either. After harvest, it will be very difficult to find out which type of error was made.

To avoid such personal judgements and the errors they entail, it is best to select the sample at random; that means entirely by chance.

6.3 Random sample

A random sample means that every element of the population has the same chance of being selected for the sample, without any preference being given to one element or another.

For example: If a random sample of the farmers in a village is to be taken, no farmer should be put aside as being 'too lazy', 'too rich', 'too old', or whatever. Every farmer in the village must have the same chance of being selected.

Selecting a random sample is a very simple procedure which - provided the sample is large enough - almost guarantees a representative sample. One simply writes the name of each element of the population (which can be villages, farmers, fields, etc.) on a small piece of paper (one name per paper). One then folds the papers so that the names cannot be seen, and mixes the papers around in a hat or a box. Next, one takes the required number of names out of the hat or box and these then form the sample.

When farmers are being selected to form a sample, the selection can best be done in front of them all so that they can see that there is no preference for one farmer or another. The more the farmers are involved at the beginning of the survey, the better they will participate later on.



A random sample is being selected

6.4 Stratified random sample

If the population can be divided into subgroups, a modified approach to the random sample is used. To be sure that each subgroup is properly represented, a stratified random sample is taken. A stratified random sample is a sample in which all subgroups (or strata) of the population are represented by a predetermined number of elements. The number of elements need not be in proportion to the size of each subgroup in the population.

Example of selecting a stratified random sample

A population of 6,000 farmers is to be surveyed. There are three distinct subgroups in this population: 1,500 are traditional farmers, 4,000 farmers use animal traction, and 500 farmers use tractors. A stratified sample of 60 farmers is to be selected from this population.

It would be possible to select samples which are in proportion to the size of the subgroups. There would then be $\frac{1,500 \times 60}{6,000} = 15$ traditional farmers in the sample, $\frac{4,000 \times 60}{6,000} = 40$ farmers with animal traction, and $\frac{500 \times 60}{6,000} = 5$ farmers with tractors. A subsample of only 5 elements, however, is too small to be representative of its subgroup so instead, 20 farmers are selected from each subgroup. This makes it easier to compare the results achieved by each subgroup. Later, when the results of the survey are being generalized to apply to the whole population, the proportional size of each subgroup will be taken into account.

6.5 Size of the sample

It is difficult to decide how big a sample should be, but, in general, one can say that the larger the sample is, the better it will represent the population. On the other hand, the sample size will be limited by the work load that each enumerator can handle.

The more differences there are between the elements of a population, the larger the sample will have to be if it is to remain representative.

For example: Suppose a factory makes dresses in only one size. A customer wants to know whether this size fits her or not. She can find this out by taking a sample of one dress and trying it on. She will then be able to judge whether all the dresses made by that factory fit her or not. In other words, a sample of one dress is representative of the entire population of dresses.

After having tried on the dress and finding that it fitted, she discovered that the factory makes dresses in many different colours. Now

she wants to know which colour suits her best. To find this out, she has to try on a sample of one dress in each of the colours. So, because of the differences in the elements of the population, the second sample has to be much larger than the first.

There is no relation between the number of elements in a sample and the number of elements in the population.

For example: A sample of 10 farmers may satisfactorily represent a population of 100 farmers, but the same 10 farmers may equally well represent a population of 1,000 farmers.

As a rule of thumb, a sample should contain at least 10 to 15 elements. Larger samples are required if the unit director expects that he will have to reject some of the elements after the survey because the information on these elements is incomplete or incorrect. If so, he should select enough elements that he still has 10 to 15 left after rejection.

It may also happen that the sample will later have to be divided into smaller groups so that the results of each group can be compared with one another. In such cases, the sample should be large enough that, even if some of its elements have to be rejected, 10 to 15 elements still remain in each group.

6.6 Generalizations from sample data

A sample which has been chosen correctly will be representative of the population, so the results obtained from the sample can be generalized to apply to the whole population as well.

For example: Suppose that a sample of 300 households has revealed that the average sorghum production per household was 720 kg. It can then be assumed that the population also produced an average of 720 kg of sorghum per household. If the size of the population is known, the total sorghum production can be estimated from the sample data.

This kind of information can be very useful to the government or the marketing board, who may need to know whether there is a food surplus or a food deficit in an area soon after harvest.

For example: If there are 3,750 households in the population, the total sorghum production will be $720 \times 3,750 = 2,700,000$ kg (or 2,700 tons). If 30 households in the sample (10 per cent of the 300) did not produce enough sorghum to feed their members, it can be estimated that 10 per cent of the population did not produce enough either. This means that 375 farms ($\frac{3,750 \times 10}{100} = 375$) may be in need of food aid before the next harvest.

Chapter 6 : Questions

- I. An agricultural development project is to be implemented in an area. The project will first aim at increasing the production of cash crops by introducing new seed varieties, fertilizers, and animal traction. Theoretically, the project should reach all the farmers in the area, but not all of them (yet) grow cash crops. To ensure that the project is well adapted to the needs of the farmers, a monitoring and evaluation unit has been created. The first two surveys that the unit will conduct will gather data on:
- The production figures of the cash crops and the cost of their production;
 - The crop rotations practised by the farmers.
- a) What is the population in each of these surveys?
b) Can the surveys be done on samples of the population?
- II. In a region with 50,000 inhabitants, a survey has been conducted to find the agricultural income per household. All households are farming households. The average household has 8 members. A representative sample of 100 households was taken. The sample revealed an average agricultural income of 88,000 CFA per household.
- a) How many households are there in the population?
b) What is the average income per person in the region?
c) What is the total income in the region?
- III. In an area with 250,000 households, the average farm size is known to be 4 ha, of which 3 ha are cultivated with cereals. In an average year, one hectare produces 600 kg of cereals. A household needs 2.4 tons of cereals a year for its own consumption.
- a) What is the total surplus (or shortage) of cereals in the area in an average year?
b) If the area is to meet its exact cereal requirements, how many kilograms of cereals should one hectare of land produce?

7.1 General

On his survey forms, an enumerator writes down long lists of data that he has gathered. This mass of information is unnecessary for someone who only wants to know the results of the survey, not all the details. The data therefore have to be grouped in a systematic way so that the results of the survey can be presented clearly and concisely.

To show how this is done, we shall take an example of two villages. (This example will continue into the next chapter.) The farmers in these villages all grow sorghum and all use the same farming techniques. The only thing that is different between the two villages is the rainfall: Village I gets less rainfall than Village II. The objective of the survey is to find out whether the farmers in the higher-rainfall village get a better sorghum yield than the farmers in the lower-rainfall village. In each village a random sample of farmers is taken.

The director of the unit wants to select samples which are as large as possible because he expects the quantities of sorghum produced by the farmers to vary widely and he wants the samples to be as representative as possible. In each village, however, there is only one enumerator, who must do this survey in addition to his regular program. In Village I, the enumerator is not able to handle more than a sample of 24 farmers. The enumerator in Village II, who has a less heavy work load, can handle a sample of 33 farmers.

During the crop season the enumerators gather data about the area that each of these farmers has under sorghum. At the end of the season, the enumerators record how much sorghum each farmer has produced. These production figures cannot be used directly, because a production of 2 tons obtained on 3 ha means something different from 2 tons obtained on 5 ha.

The production figures therefore have to be converted to yields. A yield expresses the number of kilograms of crop that a field would produce if its area was precisely one hectare. To find a yield, one divides the total amount of a crop produced by a farmer by the area on which he grew that crop. The result is expressed in kilograms per hectare. The sorghum yields obtained in this way are presented in Table 7.1.

7.2 Tabulation

Table 7.1 not only lists the yields obtained by the farmers, it also presents information that makes the table understandable to anyone who reads it. The heading explains exactly what information is presented in the table, and tells where the information was obtained, and when.

The heading of a table should always contain all the information necessary for any person to understand the table. This is important because often the tables of a report are copied and sent to people who must be able to understand them without the rest of the report. The columns and rows of a table should all have titles showing clearly in short words what is presented in the column or row and what unit of measurement is used.

7.3 Averages

The average of a group of data is the sum of all the values in the group divided by the total number of data. By using averages, it is possible to summarize a great many data because they are then expressed as one number.

Table 7.1. Data on sorghum production and yields for samples in Villages I and II in 1979

Number of farmers	Village I			Village II		
	Area sown (ha)	Production (kg)	Yield (kg/ha)	Area sown (ha)	Production (kg)	Yield (kg/ha)
1	3.5	4,410	1,260	4.3	3,999	930
2	0.9	846	940	0.8	640	800
3	4.9	4,802	980	0.7	1,120	1,600
4	0.8	328	410	3.3	2,013	610
5	5.0	3,400	680	3.5	1,085	310
6	0.6	528	880	4.4	3,564	810
7	0.6	570	950	0.7	420	600
8	4.5	1,125	250	3.3	4,422	1,340
9	0.7	525	750	2.7	3,456	1,280
10	2.3	3,496	1,520	3.8	2,090	550
11	1.0	820	820	2.3	3,059	1,330
12	1.2	1,188	990	2.7	1,728	640
13	2.6	2,418	930	0.6	678	1,130
14	3.9	4,836	1,240	3.2	4,288	1,340
15	0.9	423	470	2.3	2,392	1,040
16	0.7	525	750	3.6	2,304	640
17	4.1	5,494	1,340	0.9	288	320
18	3.0	1,860	620	0.8	872	1,090
19	0.8	632	790	0.7	665	950
20	2.3	2,277	990	0.5	440	880
21	3.0	2,820	940	2.3	2,507	1,090
22	2.1	3,213	1,530	0.9	882	980
23	1.9	2,014	1,060	3.9	2,730	700
24	4.6	3,450	750	1.5	1,710	1,140
25	-	-	-	2.6	2,470	950
26	-	-	-	1.1	1,210	1,100
27	-	-	-	3.8	3,268	860
28	-	-	-	2.3	1,794	780
29	-	-	-	2.6	1,328	830
30	-	-	-	3.8	3,268	860
31	-	-	-	4.0	3,080	770
32	-	-	-	1.8	1,998	1,110
33	-	-	-	2.7	2,700	1,000

For example: Say that we want to know the average yield of sorghum per hectare in Village I. We find this as follows. We add up all the yields listed for Village I in Table 7.1 and then divide the sum by 24 (the number of data listed):

$$\frac{1,260 + 940 + 980 + 410 + 680 + \dots + 750}{24} = 910 \text{ kg/ha}$$

To give another example: Suppose one wants to know the average weight of sorghum in the dishes sold at the market. Say that five dishes are selected at random. They weigh 2.8 kg, 2.6 kg, 2.8 kg, 2.9 kg, and 2.9 kg. The average weight of sorghum in a dish is:

$$\frac{2.8 + 2.6 + 2.8 + 2.9 + 2.9}{5} = 2.8 \text{ kg}$$

Sometimes, when calculating averages, one gets an answer that cannot exist in reality. The average number of people in a household, for instance, may be 10.2 and the average number of sheep per farmer may be 4.1. Although 0.2 of a person or 0.1 of a sheep cannot, of course, exist in reality, these numbers make sense as averages and are quite acceptable figures.

For example: Suppose one wants to find out the average number of children per household in a village. There are six households with the following numbers of children:

Household 1 8 children
 Household 2 9 children
 Household 3 5 children
 Household 4 8 children
 Household 5 6 children
 Household 6 3 children

The average number of children per household is:

$$\frac{8 + 9 + 5 + 8 + 6 + 3}{6} = 6.5$$



A traditional household

7.4 Dispersion

An average is only a simplified presentation of the data; it does not show whether the values of the data are grouped closely around the average or not.

For example: The average of 1 and 21 is 11. The average of 10 and 12 is also 11 but the values 10 and 12 are much closer to the average than 1 and 21 are.

The matter of how the values are located around the average is called the dispersion. The higher the dispersion, the more spread out are the values. The values 1 and 21, for instance, are more highly dispersed than 10 to 12, although their average is the same. A way to measure the

dispersion is to calculate the range of the values. The range is the difference between the highest value and the lowest value. A small range means a low dispersion, or in other words that the highest and the lowest values are very close to each other. A large range means a high dispersion, or in other words that there are great differences between the highest and the lowest values. When an average is given in a report and the range is given as well, this shows the dispersion of the data.

For example: For the sorghum yields of Village I listed in Table 7.1, the range is the difference between the best yield of 1,530 kg/ha (Farmer 22) and the worst yield of 250 kg/ha (Farmer 8). The range is thus $1,530 - 250 = 1,280$ kg/ha. In a report, one can say 'The average sorghum yield of farmers in Village I was 910 kg/ha, with a range of 1,280 kg/ha'. A person who has not seen the original data of Table 7.1 will know when he reads this that there are great variations in the yields obtained by the farmers and that some have much more than the average of 910 kg/ha and some have much less.

Chapter 7 : Questions

- I. In a village of 250 households, a farm survey gathered data about the number of persons per household. From a random sample of 15 households, the following numbers of persons were obtained: 8, 10, 7, 11, 12, 11, 2, 8, 8, 9, 18, 14, 6, 10, and 7.
- What is the average number of persons per household?
 - What is the range of the number of persons per household?
 - Is this average and this range also true for the entire village? Explain your answer.
- II. Samples were selected in two villages for an income survey. The results of the survey showed that the average income of a household in Village A was 110,000 CFA, with a range of 20,000 CFA, and in Village B it was 125,000 CFA, with a range of 80,000 CFA.
- Which village has the poorest households?
 - Which has the richest?
- III. Suppose a farmer harvests 100 bags of millet from his field. During the harvest, the enumerator comes and weighs 5 of these bags at random. The weight of these bags is 17.5, 18.5, 16.5, 17, and 15.5 kg.
- What is the average weight of a bag of millet?
 - Estimate (in kilograms) the production of that field?

As explained in Chapter 7, the range shows how far apart are the values of the two most extreme data; it does not show how the data are distributed within the range. In many cases, most of the data are close to the average, with only a few very high and very low values.

For example: If you measure the height of 30 adult men, you will probably find a few very tall ones and a couple of very short ones, but most of them will be about average height.

8.1 Frequencies

To show more clearly how the values are distributed, the data can be set out in a frequency table. This is a table in which the data are rearranged in small groups, called classes. These classes show the number of data that belong in each class. Classes should be selected in such a way that they are all the same size and that they do not overlap one another but join.

To provide good information, enough classes should be taken, say at least six. To choose the classes, the range of data (the highest value minus the lowest value) is divided by the number of classes required. The result is rounded off to make the classes simpler to work with. The first class therefore does not necessarily start with the lowest value nor does the last class necessarily end with the highest value. To

demonstrate the process, we shall use the data of Table 7.1, the sorghum yields of Villages I and II.



Farmers harvesting sorghum

Example of preparing a frequency table

In Village I, the difference between the best yield (1,530 kg/ha) and the worst one (250 kg/ha) is $1,530 - 250 = 1,280$ kg/ha, which is the range of data. To group the data into six classes, each class could be $\frac{1,280}{6} = 213.33$ kg/ha. Instead of using this awkward number, we shall take classes of 250 kg/ha. (If we had taken classes of 200 kg/ha, these would not have covered the range.)

The six classes together cover a range of $6 \times 250 = 1,500$ kg/ha, which is greater than the range of data. Therefore the first class should start below the lowest value, while the last class will end above the highest value. The lowest value is 250 kg/ha, so the first

class can be the class which contains all the values between 150 kg/ha and 400 kg/ha (400 kg not included). This can be written in the frequency table as Class: 150 - < 400. (The sign '- < 400' means up to, but not including 400.) The second class contains the data with values of 400 or more, up to 650 kg/ha (650 kg/ha not included) which is represented as Class: 400 - < 650. The other classes are delimited in the same way.

We can now make a frequency table (Table 8.1). It contains two columns: the column on the left shows the classes; the column on the right shows the number of data belonging in each class; this number is the frequency.

Table 8.1. Frequency distribution of sorghum yields of a sample of 24 farmers in Village I, 1979

Sorghum yields in kg/ha (classes)	Number of farmers (frequencies)
150 - < 400	1
400 - < 650	3
650 - < 900	7
900 - < 1,150	8
1,150 - < 1,400	3
1,400 - < 1,650	2
Total	24

(It is a good idea to add up the frequencies to make sure that all the data have been included.)

The average sorghum yield in Village II, where 33 farmers were selected for the sample, is 920 kg/ha. This is slightly more (10 kg/ha) than in Village I. The difference is so small, however, that a simple comparison of the average yields of the two villages does not provide much information. A comparison of the frequency distributions, however, can tell us much more.

The frequency table for the yields of Village II is shown in Table 8.2.

(Note that Table 8.2 uses the same classes as Table 8.1.)

Table 8.2. Frequency distribution of sorghum yields of a sample of 33 farmers in Village II, 1979

Sorghum yields in kg/ha (classes)	Number of farmers (frequencies)
150 - < 400	2
400 - < 650	5
650 - < 900	9
900 - < 1,150	12
1,150 - < 1,400	4
1,400 - < 1,650	1
Total	33

It is still difficult to compare the frequency distributions of the two villages because the number of farmers surveyed in each village was different. The next section will explain how the frequencies can be made comparable.

8.2 Relative frequencies

In both Village I and Village II, the number of farmers who obtained yields of 1,150 kg or more is the same (5 farmers). But because 24 farmers were surveyed in Village I and 33 in Village II, it would not be correct to conclude that the group of farmers with a yield of 1,150 kg or more is of equal importance in both villages: 5 out of 24 is a relatively larger and therefore more important group than 5 out of 33.

To enable comparisons between samples of different sizes, the original frequencies have to be converted into relative frequencies. This means that the number of farmers belonging in a class has to be recalculated to represent the number of farmers that would have been in that class if 100 farmers had taken part in the survey. This number is known as the percentage.

The percentage is found by dividing the original frequency by the total number of data and multiplying the result by 100. So the percentage of farmers with a yield of more than 1,150 kg/ha is $\frac{5 \times 100}{24} = 20.8$ in Village I and $\frac{5 \times 100}{33} = 15.1$ in Village II. The calculated percentages are then used to prepare the relative frequency table, which is a table that replaces the original frequencies with percentages. Table 8.3 shows such a table.

Table 8.3. Relative frequency of sorghum yields in samples of farmers in Villages I and II, 1979

Sorghum yields in kg/ha (classes)	Percentage of farmers (relative frequency)	
	Village I	Village II
150 - < 400	4.2	6.1
400 - < 650	12.5	15.1
650 - < 900	29.2	27.3
900 - < 1,150	33.3	36.4
1,150 - < 1,400	12.5	12.1
1,400 - < 1,650	8.3	3.0
Total	100.0	100.0

Since the sum of the frequencies in the classes equals the total frequency, the relative frequencies always add up to 100. This fact can be used to check the calculations. If the relative frequencies are rounded off, it should be done in such a way that their sum is still 100.

If one examines Table 8.3, one can see that the results obtained by farmers in Village I have about the same frequency distribution as those in Village II. The differences are so slight that one cannot conclude that the better rainfall in Village II has any noticeable influence on the yields.

8.3 Graphic presentation of frequency tables

The information presented in a frequency table can also be presented in

a graph. This is a drawing which makes it easier to compare the information. Such drawings are delimited by a horizontal and a vertical line, each called an axis. The horizontal axis represents classes of data and the vertical axis represents the frequencies.

Like the heading of a table, the heading of a graph should provide all the information needed for anyone to understand what it represents. What was said about the headings of the columns and rows of a table (Chapter 7) now applies to the titles of the vertical and horizontal axes. Each axis should have a title showing clearly what is measured on that axis. The unit of measurement used should also be mentioned. The graphic form of a frequency table is called a frequency histogram. How it is constructed will be explained below, using the yield data of Village I.

Example of a frequency histogram

The frequency distribution of the yield figures of Village I (Table 8.1) is to be presented in a frequency histogram. The classes are measured along the horizontal axis. The frequencies are measured along the vertical axis. A rectangle is drawn above each class to represent the number of data in that class. The result is shown in Figure 8.1.

In the same way, a histogram can be made of the relative frequencies. This will produce exactly the same histogram.

For a histogram to be properly interpreted, its shape should be as square as possible. This means that the width of the histogram (representing the range) and its height (representing the highest frequency) should be about the same. If two or more histograms are to be compared, they should be made to the same scale.

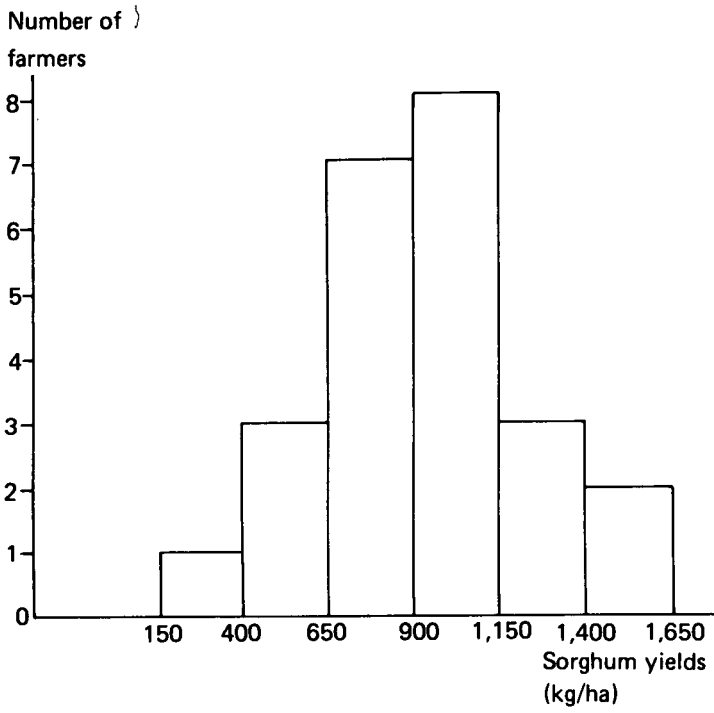
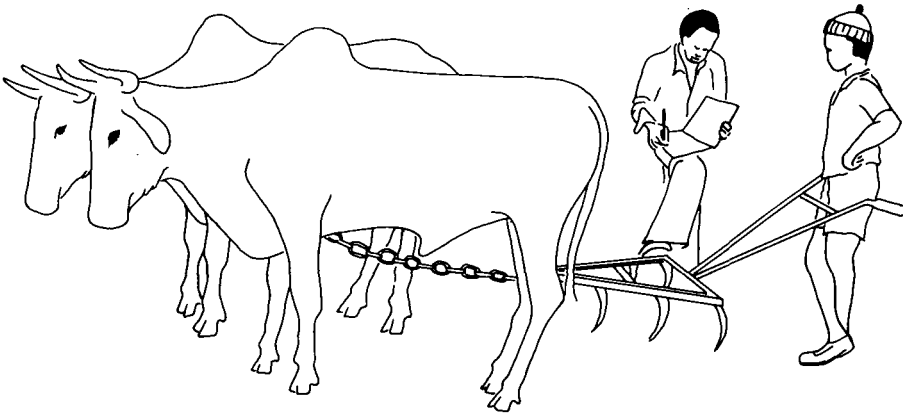

Figure 8.1. Frequency distribution of the sorghum yields (kg/ha) of a sample of 24 farmers in Village I, 1979

Chapter 8 : Questions

In an area where animal traction has recently been introduced, a monitoring and evaluation unit is conducting a survey to find out whether this new technology is giving the farmers who use it a higher net income. The net income is the income that remains after all the costs of production have been deducted. (Obviously, farmers who own animals for traction will have higher costs than those who do not, because they must feed and care for their animals and pay for the equipment.)



Conducting an interview on the use of animal traction

A random sample has been taken, stratified into two subgroups: farmers who own animals for traction and farmers who do not. Originally, each subgroup had 25 elements, but some of these had to be rejected because their data were incomplete. Some data were incomplete because the farmers would not cooperate and the enumerators could not obtain the data. Others were incomplete because one enumerator had not asked all the questions he should have and, after that had been noticed, it was too late to obtain the missing data. After rejection, 20 farmers were left in the subgroup that owned animals and 15 in the subgroup that did not. Their data are presented in Table 8.4.

Table 8.4. Net income figures from a stratified random sample of farmers in project area, 1980 (in CFA)

Farmers with animal traction				Farmers without animal traction		
74,800	52,900	51,800	89,300	51,400	78,000	26,300
69,200	70,200	42,200	108,300	61,500	46,700	58,500
76,400	65,700	92,300	72,100	30,800	30,000	48,300
89,200	47,300	83,900	83,800	45,400	35,500	29,300
76,000	30,800	61,300	90,200	67,700	46,200	50,900

- a) Calculate the average and the range of the net incomes for both subgroups.
- b) Make a frequency table of the net incomes of both subgroups in such a way that they can be compared.
- c) Construct a frequency histogram from these tables for both subgroups in such a way that they can be compared.
- d) What conclusions can you draw about the incomes of the two subgroups of farmers?
- e) Can these conclusions be generalized to the entire population? (Give the reason for your answer.)

9.1 General

In this chapter, we shall look at the changes that take place in something we are observing over a period of time. Such changes are not usually measured by their absolute values, because this does not provide us with enough information.

For example: If the price of two products, A and B, increases by 5 CFA, this fact alone does not show whether this is a big increase or only a small one. Suppose that Product A is a kilo of sorghum which costs 55 CFA and Product B is a refrigerator which costs 114,775 CFA. A price increase of 5 CFA for the sorghum is judged as high, whereas 5 CFA added to the price of the refrigerator is hardly any increase at all.

Changes are therefore often better presented as relative changes, which means that the increase in value of something is divided by its original value. If the result is multiplied by 100, the change is expressed as a percentage. If the value has decreased, the relative decrease is calculated in the same way by dividing the decrease by the original value.

Remember that it is always the value of the thing at the *beginning* of the period which is used to divide the change, never the value at the end.

Example of calculating relative change

The population of a country in 1970 was 5,769,000. In 1971 it was 5,902,000. From 1970 to 1971, the population had increased by 5,902,000 - 5,769,000 = 133,000. An increase of 133,000 inhabitants in a year will be more significant in a country of 5 million inhabitants than it would be in a country of 50 million. To really understand this, it is better to look at the percentage by which the population has increased. This is calculated by dividing the number of additional people in that year by the total number of people at the beginning and multiplying by 100. So the above increase in population is:

$$\frac{133,000 \times 100}{5,769,000} = 2.3 \text{ per cent (rounded off)}$$

If the country had had 50 million inhabitants to start with and the same number of additional people in that year, the increase would have been:

$$\frac{133,000 \times 100}{50,000,000} = 0.3 \text{ per cent (rounded off)}$$

With some things, the rate of change can be much higher and can even be more than 100 per cent.

For example: In a certain town, it was rare to find a moped for sale until 1976, when a merchant started importing them and many people bought one. In 1975 there were only 572 mopeds, but in 1977 there were 1,481, so the rate of increase was:

$$\frac{(1,481 - 572) \times 100}{572} = 159 \text{ per cent (rounded off)}$$

An increase of 100 per cent means that the quantity had doubled. If it increases by 200 per cent, it has tripled. If something decreases by 50 per cent, that means that it has been reduced to half its original value.

9.2 Constant increase

Some quantities increase by the same percentage every year. This means that the absolute increase becomes bigger each year. If the rate of increase of a population remains constant, there will be more additional people each year. This will be explained in the next example.

Example of constant increase

Suppose that Town A has 10,000 inhabitants in 1975 and the rate of increase remains stable at 3 per cent a year. Table 9.1 shows the changes in population over the years, up till 1999.

Table 9.1. Changes in population in Town A from 1975 to 1999 with a 3 per cent rate of increase a year

Year	Increase in population (3% of last year's population)	Total population at the end of the year
1975	-	10,000
1976	300	10,300
1977	309	10,609
1978	318	10,927
1979	328	11,255
1980	338	11,593

1985	391	13,439

1990	454	15,580

1995	526	18,061
1996	542	18,603
1997	558	19,161
1998	575	19,736
1999	592	20,328

With the population increasing by 3 per cent a year, it will double in 23.5 years. This will happen no matter how big or how small it was to start with. If the rate of increase is lower, the population will take a longer time to double. If the rate of increase is 1 per cent, for instance, it will take 70 years for the population to double.

The same principle applies no matter what is being measured. If the price of goods is increasing by an average of 10 per cent a year because of inflation, the prices will double in 7 to 8 years: something that costs 100 CFA in 1980 will be likely to cost 195 CFA in 1987 and 214 CFA in 1988.

9.3 Ratios

The ratio between two quantities means the numbers of times one can be divided by the other. Ratios are often useful when one is comparing quantities, whether they are quantities of the same kind of things or quantities of different kinds of things.

Ratios between quantities of different kinds

If a farmer harvests 375 kilograms of cotton from 0.5 hectare of land, we can calculate how much he would have harvested if his field had measured one hectare: $\frac{375}{0.5} = 750$ kg/ha. This ratio is called the yield; it is expressed in a number of kilograms per hectare. The harvests obtained from different sized fields can all be converted into yields, which makes it possible to compare the productions of the field.

Another ratio often used is speed; this is the ratio between the distance covered and the time it took to cover that distance. If it takes a farmer two hours to walk to a market twelve kilometres away, his speed is $\frac{12}{2} = 6$ km/h. A car goes much faster; in two hours it could travel 220 km, going at a speed of $\frac{220}{2} = 110$ km/h.

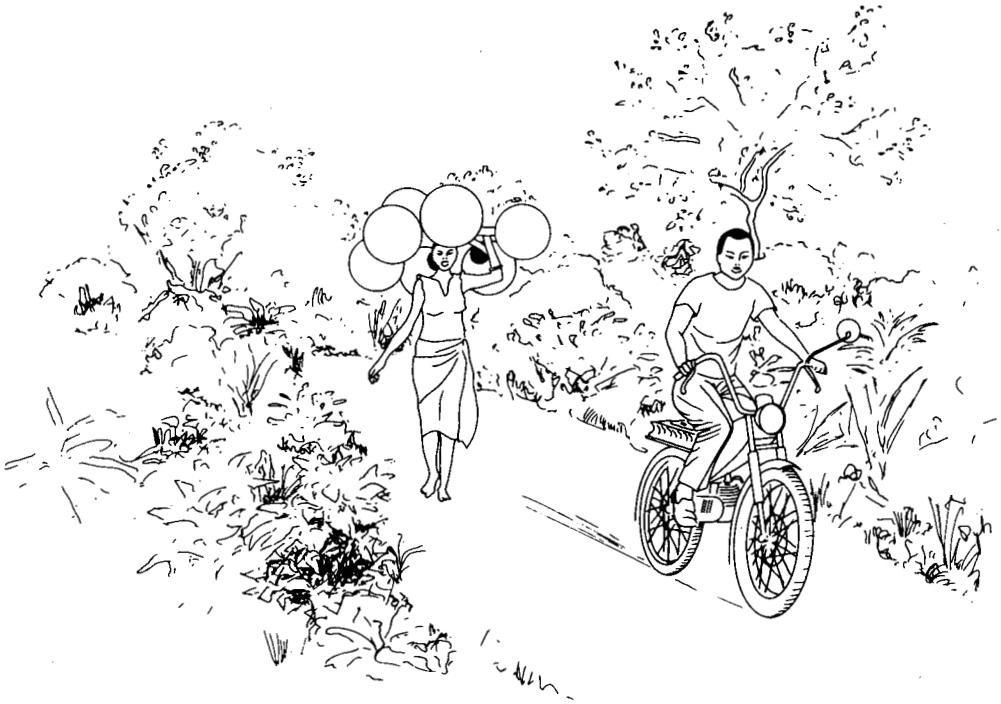

Enumerator on moped

When giving a ratio of quantities of two different kinds, the units used should always be indicated. Examples of some commonly used ratios are given below:

Salary per day: Somebody earns fifty dollars for five days of work. His salary for one day's work can be calculated: total salary divided by number of days worked for that salary: $\frac{50}{5} = 10$ dollars a day.

Population density: There are 15,000 inhabitants in a region of 1,000 square kilometres. The population density is the number of people in the region divided by the area of the region: $\frac{15,000}{1,000} = 15$ inhabitants per square kilometre.

Gross National Product per capita: In one year, a country of 1 million inhabitants produced goods and services worth 800 million

dollars. This is called the Gross National Product. The Gross National Product per capita is the value of the country's production divided by the number of people living in that country: $\frac{800,000,000}{1,000,000}$
= 800 dollars per capita.

Ratios between quantities of the same kind

To find the ratio between two quantities of the same kind, one simply divides one quantity by the other, as before. Since both are of the same unit of measurement, the ratio itself has no unit of measurement. A ratio can be calculated for any two quantities.

Suppose Country A has 50 million inhabitants and its neighbour, Country B, has 20 million inhabitants. The population ratio of Country A to Country B is $\frac{50}{20} = 2.5$. This means that the first country has two-and-a-half times as many inhabitants as the second one.

It is also possible to calculate the population ratio of Country B to Country A, which is $\frac{20}{50} = 0.4$. This means that the population of Country B is four-tenths of the population of Country A (which is exactly the same as saying that the population of A is 2.5 times as big as the population of B).

This example shows how important it is to define clearly which ratio is being calculated. One must always say whether it is the ratio of A to B or the ratio of B to A.

A ratio commonly used in banking is the exchange rate between money from different countries. The exchange rate of Money A to Money B is: $\frac{\text{Value of one unit of Money A}}{\text{Value of one unit of Money B}}$. This determines how much money of Country B one will be given in exchange for one unit of money from Country A.

For example: If the exchange rate of the dollar to the CFA is 240, this means that each dollar can be exchanged for 240 CFA.

9.4 Graphic presentation of changes over time

The changes that take place in something over a period of time can also be presented in a graph. The way to construct such a graph will be explained by an example.

Example of a time graph

The price of white sorghum has been surveyed at Markets A and B over a period of one year. Table 9.2 shows the average monthly prices calculated from the survey data.

Table 9.2. Average monthly price per kg of white sorghum at Markets A and B in 1979 (in CFA/kg)

	J	F	M	A	M	J	J	A	S	O	N	D
Market												
A	58	62	67	65	61	68	69	68	67	58	46	50
B	55	60	65	65	68	65	72	72	68	61	50	48

It is much easier to see the fluctuations in price if they are presented in a graph. To draw the graph, one first draws a horizontal axis and then a vertical axis. On the horizontal axis, one marks off the months of the year and on the vertical axis the prices. The time is always put on the horizontal axis.

Above each month, the price for that month is marked with a cross, as if imaginary lines ran upwards from that month and sideways from the corresponding price. When the crosses have been marked for each month, one then draws a straight line, joining one cross to the next.

Figure 9.1 shows the graph of prices for white sorghum in 1979 at Market A. The imaginary lines for March, when the price was 67 CFA, have been dotted in.

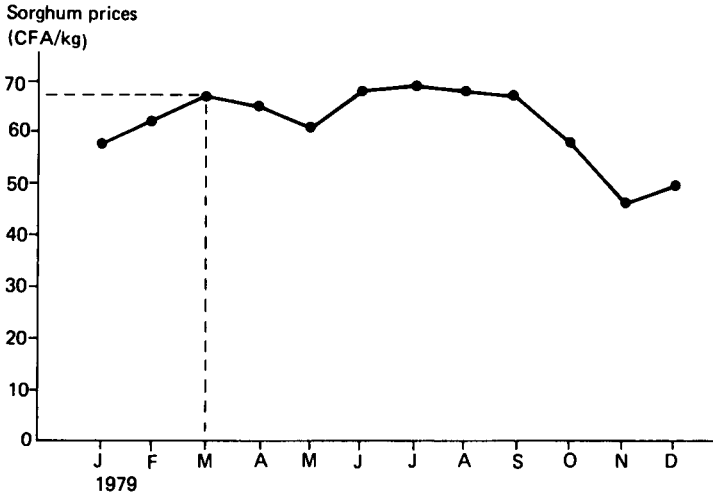

Figure 9.1. Price of white sorghum in 1979 at Market A, in CFA/kg

In the same figure, one can draw a graph of the prices at Market B. As can be seen in Figure 9.2, this makes it easy to compare the prices at the two markets.

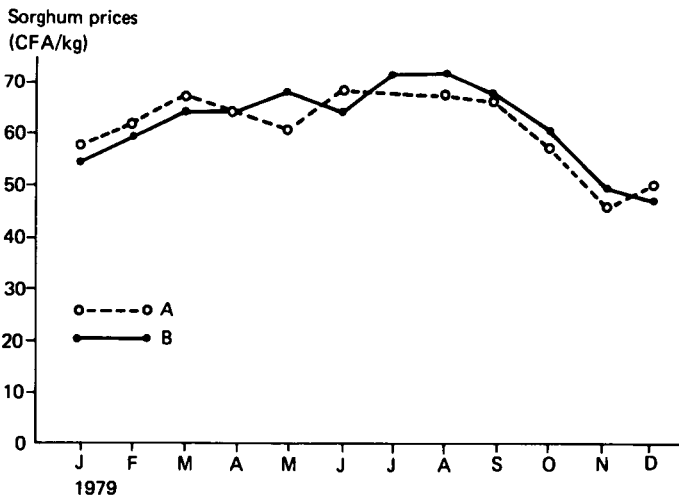

Figure 9.2. Price of white sorghum in 1979 at Markets A and B, in CFA/kg

Chapter 9 : Questions

- I. The average inflation in a country was calculated to be 8 per cent in a certain year. This means that in that year the average price of all goods increased by 8 per cent. The price of a television set increased from 150,000 CFA to 155,000 CFA. Compared with the average price, did T.V. sets become more expensive that year?
- II. Because of new technical developments, the price of a calculator could be reduced to one-fifth of its original value. What is the relative change in the price of a calculator?
- III. In a certain country, there is a great disparity in incomes. In agriculture, an average household of 10 persons earns 150,000 CFA a year. An average government employee with a household of 5 persons earns 50,000 CFA a month.
- What is the annual income per capita in the two households?
 - Use a ratio to compare the two incomes per capita.
 - By what percentage would the poorer household have to increase its income to have the same income as the richer household?
- IV. The price of rice was surveyed at a small market throughout 1978 and 1979. The average monthly prices are presented in Table 9.3.

Table 9.3. Average monthly price of rice at a small market in 1978 and 1979 (in CFA/kg)

Year	Price of rice in CFA/kg per month											
	J	F	M	A	M	J	J	A	S	O	N	D
1978	66	63	66	73	72	77	75	71	78	70	57	60
1979	71	72	71	75	76	77	73	81	63	62	59	59

- Draw a time graph of these prices.
- What is the average price of rice over the two years and what is the range?

Measuring a field is a complex and time-consuming task. It has to be done in most farm surveys, however, so that the area being cultivated by a farmer can be calculated. The sides of a field are usually measured with a measuring tape or chain, and the angles of a field with a compass. This chapter will explain how to make such measurements. But first, some basic geometry will be reviewed.

10.1 Geometry

Triangle

A triangle is a figure with three straight sides and three angles (Figure 10.1).

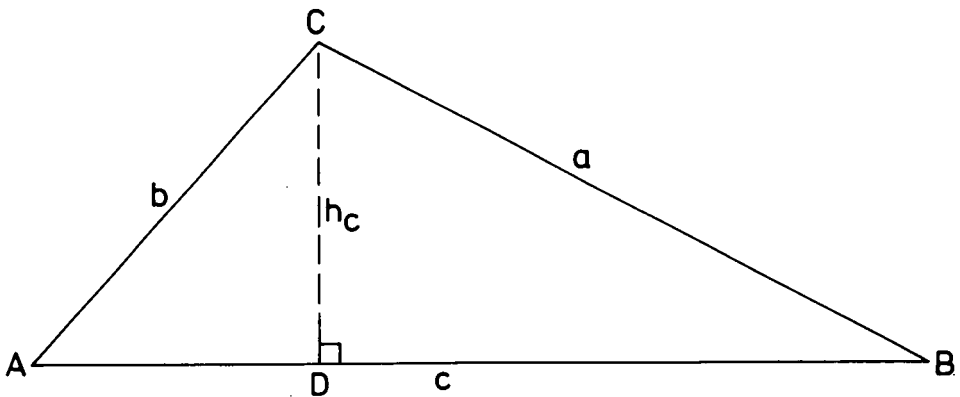

Figure 10.1. A triangle

The height of a triangle is the shortest distance between an angle and the opposite side. The height is always perpendicular to that side. Because the triangle has three angles, it has three different heights.

The area of a triangle (s) can be calculated by multiplying half of a side (called the base) by the height of the triangle corresponding to that side.

For example: If AB is taken as the base, the corresponding height of the triangle is CD (the shortest distance from AB to the opposite angle C). So the area $s = \frac{1}{2} \times AB \times CD$. If another side of the triangle is taken as the base, the height will be different but the area calculated will be the same.

Any side can be taken as the base, as long as half of that base is multiplied by its corresponding height. If the three sides of a triangle are called a , b , and c , their corresponding heights are h_a , h_b , and h_c . The area of a triangle can thus be calculated in three different ways:

$$s = \frac{1}{2} \times a \times h_a = \frac{1}{2} \times b \times h_b = \frac{1}{2} \times c \times h_c$$

The triangle is the basic figure used in calculating areas. Every figure with straight sides can be split up into triangles and its area can be calculated.

Square

A square is a figure with four straight sides of the same length and four right angles (Figure 10.2). The opposite sides of a square are parallel. This means that they are the same distance from each other over their whole length.

The area of a square is the length of a side (a) multiplied by itself. So, $s = a \times a$. This can be proved by dividing the square into two equal triangles. If one side of the square (AB) is chosen as the base of the triangle, its corresponding height is the other side (BC) and its area

is $\frac{1}{2}a \times a$. So the area of the two triangles together is $\frac{1}{2}a \times a + \frac{1}{2}a \times a = a \times a$.

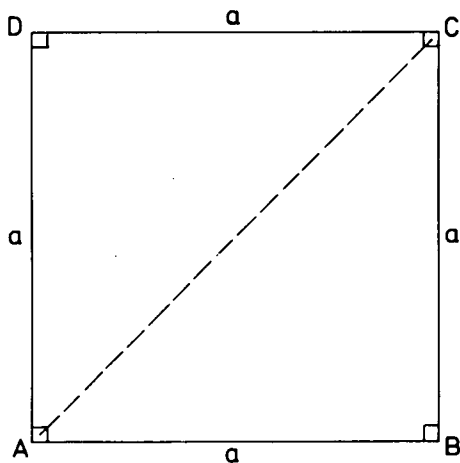

Figure 10.2. A square

Rectangle

A rectangle is a figure with four straight sides and four right angles; the two sides opposite to each other are of equal length and are parallel (Figure 10.3). The area of a rectangle is found by multiplying its length (a) by its width (b). So, $s = a \times b$. This can be proved in the same way as for a square.

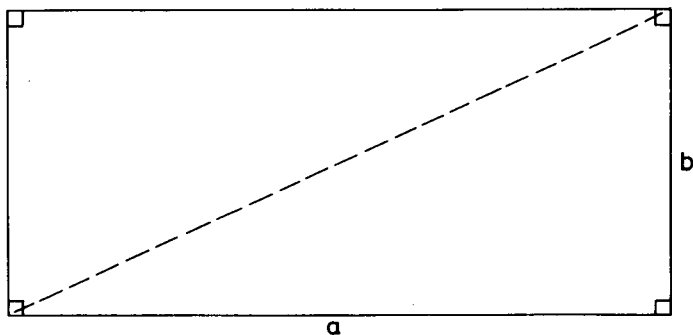

Figure 10.3. A rectangle

Trapezium

A trapezium is a figure with four straight sides in which two opposite sides are parallel but the other two are not (Figure 10.4).

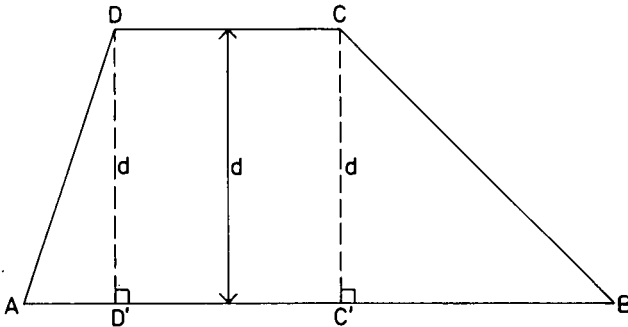
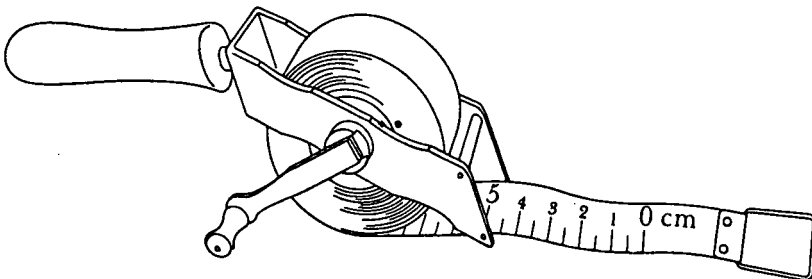

Figure 10.4. A trapezium

The area of a trapezium can be calculated by multiplying half the sum of the two parallel sides (a and b) by the distance between them (d). So, $s = \frac{1}{2}(a + b) \times d$. This can be proved by dividing the trapezium into two triangles and a rectangle as is shown in the figure.

10.2 Measuring distances

Distances are measured by a measuring tape or chain. Tapes and chains are available in many lengths, with markings at every metre or even at every centimetre. A tape is easier to use and rewind than a chain, but a chain is stronger. A person working alone can measure a distance, but measuring is easier to do if two people work together.



A measuring tape

Example of measuring a distance

Suppose that an enumerator has to measure the length of a row of cotton in a field, using a chain. First, he identifies the spot where the row begins and puts a picket into the ground at that spot. He then fixes the end of the chain to the picket, being careful that the zero marking on the chain really matches the beginning of the row. (Sometimes the outer twenty or thirty centimetres of a field are not to be included in the measurement.)

Once the chain has been fixed, the enumerator walks along the row, unwinding the chain as he goes. If the chain has been completely unwound and the enumerator has not yet reached the end of the row, he puts another picket into the ground beside the last marking on the chain, being careful to pull the chain taut so that the exact distance is measured.

He then notes the distance just measured (on a form provided for that purpose or in a notebook) and walks back to the first picket, winding the chain as he goes. He detaches the chain from the first picket, goes back to the second picket, fixes the chain to that picket so that the zero marking on the chain coincides with the second picket, and continues measuring. He proceeds in this way until he has to place another picket or until he has reached the end of the row, noting down the distances he measures. The end of the row will probably not coincide exactly with a mark on the chain, so the enumerator takes the mark which is closest to the end of the row. He then adds up all the distances measured to obtain the length of the row.

With two persons, the job becomes easier. One person stands and holds one end of the chain while the other unwinds it and notes down the measurements. No pickets need to be placed and there is no walking back and forth.

When measuring long distances, one easily forgets how many times the tape or chain has been unwound, so it is important to note down on the form or in the notebook each time the tape or chain is fully unwound.



Two enumerators measuring a distance

10.3 Measuring angles

An angle on a piece of paper is measured with a protractor. A protractor is a transparent circle or half circle with degrees marked on it. The full circle contains 360° (which means 360 degrees) and the marks 360° and 0° coincide.

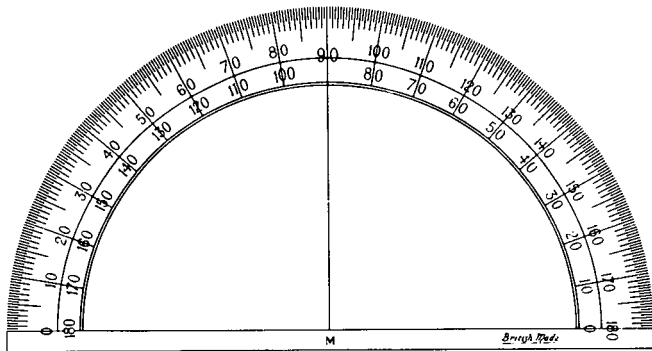

A protractor

The centre of the protractor is placed over the point where the two sides of the angles meet. The protractor is then rotated until the mark for 0° coincides with one side of the angle. The size of the angle is indicated by the mark closest to the other side of the angle. The protractor should be used correctly, as will be explained in the following example.

Example of measuring an angle on paper

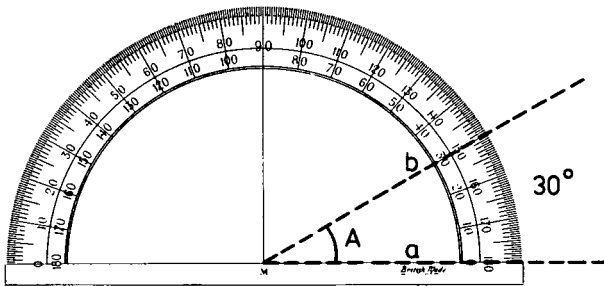
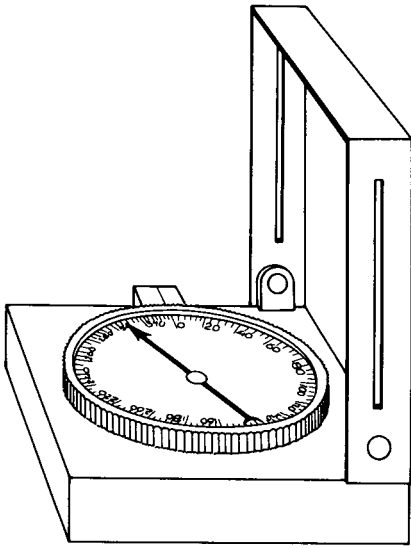

Figure 10.5. An angle of 30°

To measure Angle A in Figure 10.5, the 0° mark of the protractor is placed on Side a of the angle and the mark is read at Side b. The correct reading is 30° . If the 0° mark of the protractor is placed on Side b and the mark is read at Side a, the reading will be 330° , which is the complement of angle A (the difference between 360° and Angle A).

Measuring the angle between two sides of a field is more complex than measuring an angle on paper. In the field, instead of using a protractor, one uses a compass. A compass is an instrument with a built-in protractor and a magnetic needle which can rotate freely over the protractor. When the compass is held horizontally and still, the needle always points to the magnetic north of the earth.



A compass

What one measures with a compass is the angle formed between the side of a field and an imaginary line running towards the magnetic north. When one measures these angles for two adjoining sides of a field, the angle between the sides can be calculated.

Example of measuring an angle in a field

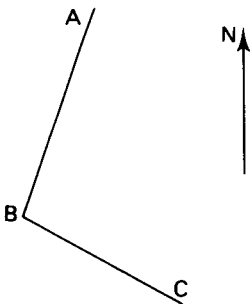

Figure 10.6. Two sides of a field

Suppose that AB and BC in Figure 10.6 are two sides of a field. The angle they form has to be measured. To do this, the enumerator places a picket at A (or gets somebody to stand there) and places himself at B. Holding the compass horizontally and turning until the 0 mark coincides with the needle pointing to the magnetic north, he aligns the picket or person with a mark on the compass. His eye, the picket or person, and the mark on the compass all have to be in a straight line. He then reads the mark on the compass, which shows the angle formed between AB and the magnetic north (e.g. 20°). After writing down this measurement in his notebook, he places a picket or person at C, he himself remaining at B, and repeats the process. With the needle on 0° , he aligns his eye, the picket or person, and the mark on the compass, notes the angle (e.g. 120°) and writes this down in his notebook. He then obtains the angle between the two sides of the field by subtracting one angle from the other (e.g. $120^{\circ} - 20^{\circ} = 100^{\circ}$).

The two sides of a field can form two different angles, and the one that is required depends on the shape of the field. Compare the two fields shown in Figure 10.7. Both have Sides AB and BC at the same angle.

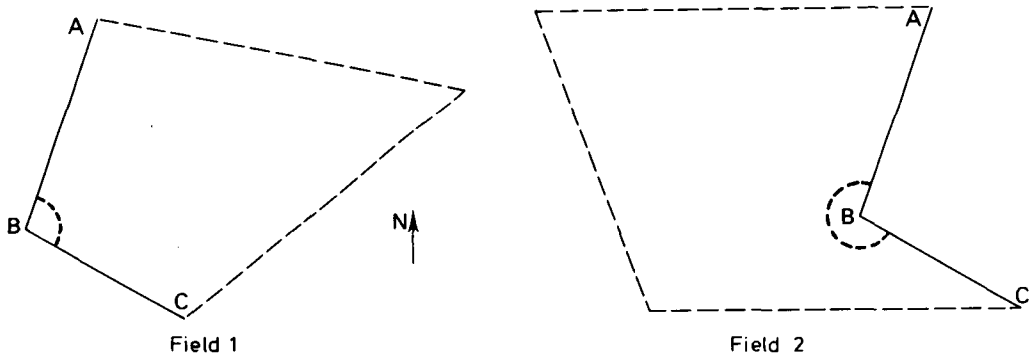

Figure 10.7. Two fields with Sides AB and BC at the same angle

For both fields, the angle required is the one inside the field. For Field 1, the angle is less than 180° (half of a circle). It is the 100° calculated earlier. For Field 2, the angle is greater than 180° . It is the complement of 100° . Both angles (the original and the complement)

add up to 360° (a full circle) so the angle required for Field 2 is $360^\circ - 100 = 260^\circ$.

10.4 Measuring a field

Before anyone starts to measure a field, he should first look at the field to see what shape it has. In traditional farming, fields seldom have the simple geometrical shapes described earlier in this chapter. The sides are often curved and the shape can be quite complex. In most cases, however, the shape of a field can be approximated by a simple figure; curved lines can be approximated by straight ones, and the field can be split up into triangles and rectangles, which can all be measured and used to calculate the area of the field.

Example of measuring a field



Figure 10.8. Field approximated by simple geometric figure

Suppose that the field shown in Figure 10.8 has to be measured. The enumerator first makes a rough drawing of the field, in his notebook approximating the curved lines with straight ones (the dotted lines in the figure). He then places a person or picket at B and, standing at A with compass and notebook, he reads the mark on the compass and notes it down on the drawing. Next, using a measuring tape or chain, he measures the distance from A to B, noting this on the drawing also. Placing the person or picket at C and himself at B, he repeats the process. He continues in this way until he has measured all the sides and angles of the field, marking them all on his drawing. When he has finished, he sends the drawing to the office, where the area of the field will be calculated.

Chapter 10 : Questions

I.

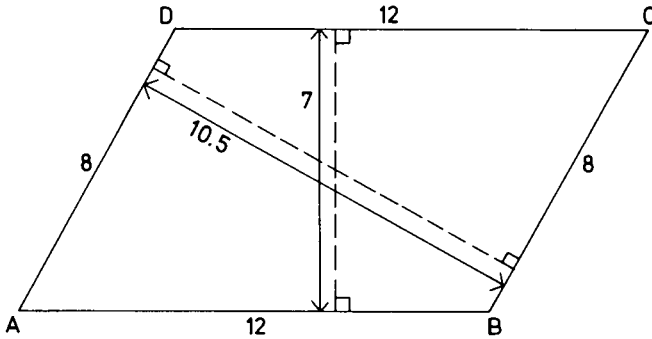

Figure 10.9. A parallelogram

The above figure is a parallelogram. This is a four-sided figure whose opposite sides are of equal length and are parallel.

Side AB = 12 m and Side BC = 8 m. The distance between Sides AB and CD = 7 m and the distance between BC and AD = 10.5 m. Calculate the area of this figure.

II. A field has the shape shown in Figure 10.10.



Scale
1:1,000

Figure 10.10. A field

- a) Approximate this field with a simple geometrical drawing that you can measure. Draw it in dotted lines on the figure.
- b) In the drawing, the scale is indicated to be 1:1,000, meaning that 1 cm in the drawing represents 1,000 cm (= 10 m) in reality. Measure on your drawing the angles between the sides and the length of each side.

III. Two enumerators are to measure a field together. The field has a fairly simple shape which can be approximated by a four-sided figure with angles A, B, C, and D.

Starting at A, the enumerators measure Side AB as 110 m and the angle it makes with the magnetic north as 210° . They measure Side BC as 207 m and its angle with the magnetic north as 270° . Side CD is found to be 213 m long and its angle with the magnetic north is 30° . Side DA is 179 m and its angle with the magnetic north is 120° .

- a) Using your protractor, make a drawing of this field to scale.
- b) Divide the drawing into a rectangle and a triangle and calculate the area of the field.

Crop growing is the main activity of farming households and forms the biggest part of the income they earn. An important part of the work of an enumerator is therefore to obtain information about the quantities of crops that are harvested.

There are many ways of estimating crop production and yields, but as most of them require that part of the crop be weighed, the use of scales will first be discussed.

11.1 The use of scales

Most enumerators will use scales to weigh the crops, and perhaps also to weigh produce bought during a market survey. A scale is a sensitive instrument and should be handled carefully. Carrying it around in the rain or in high humidity can cause it to rust; this will prevent the mechanism from working properly. Dropping a scale, or pushing its needle will also damage it.

Hanging scales

A hanging scale can be used anywhere. It can be hooked to a tree or to a nail on the outside of a house. Once the scale has been hung in position, the needle of the scale should point to zero. Because of

transport and imprecision of the instrument, the scale may indicate some weight. If so, it must first be adjusted so that the needle points to zero. This is done by turning an adjustment screw on the scale, not by pushing the needle. Since the scale will probably have to be adjusted anyway, the easiest thing to do is to first hang on the scale the sack or tray in which the crop will be weighed, and then to adjust the scale so that it indicates zero. The sack or tray is then removed from the scale, filled with the crop, and hung on the scale again. In this way, only the weight of the crop will be weighed, not that of the sack or tray. When the sack or tray is hanging very still and the needle no longer moves, the weight of the crop can be read from the scale.

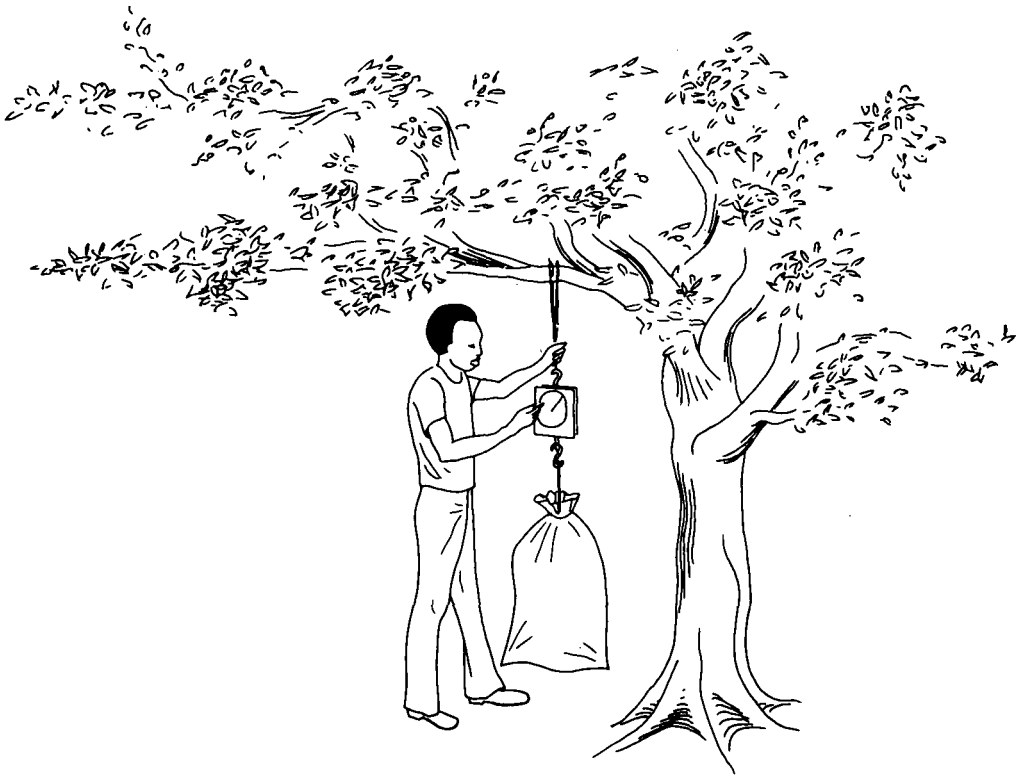

Enumerator weighing a crop

To read scales correctly, the enumerator should stand (or sit) so that his eyes are exactly in front of the needle.

Scales can only show weights up to the maximum for which they were made. If a scale has a maximum of 50 kg and quantities greater than 50 kg have to be weighed, the weighing will have to be done in batches. If the scale has markings every 100 grams, it is not possible to read weights more precisely than to the nearest 100 grams.

For example: If the needle indicates a weight somewhere between 700 and 800 grams, the enumerator should not try to guess the exact weight, but should take the marking (either 700 or 800) which is closest to the needle.

Some types of hanging scales have one or more weights attached to them. These weights have to be moved along a bar to keep the bar horizontal. The weights may range from tens of kilograms to one tenth of a kilogram or even much less. The weight of the crop is indicated by the position of the weight on the bar.

Table scales

When only small quantities are to be weighed, table scales can be used. Table scales are more precise than hanging scales, but are also more sensitive. They should therefore be kept in the house of the enumerator and not taken into the fields so that their mechanism remains in good working order.

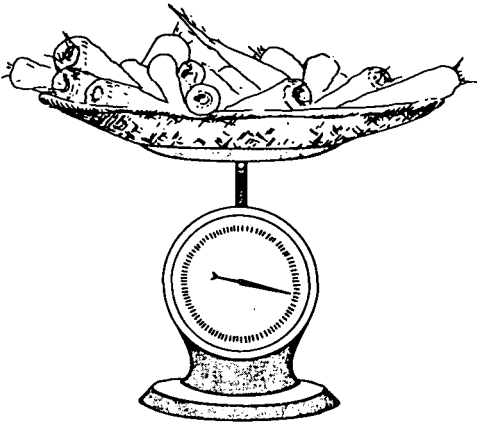
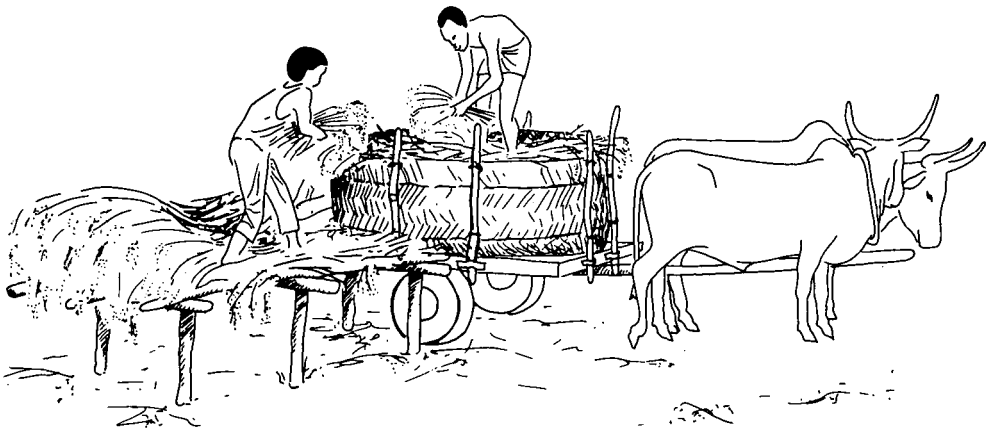

Table scales

On most table scales, the produce to be weighed is placed on a tray mounted on a spring. The principle of adjustment is the same as for a hanging scale. When being used, the scales should be placed on a flat surface and the enumerator should sit or stand so that his eyes are in front of the needle.

11.2 Direct estimates of crop production

If a field is harvested in one cut and the harvest is stored afterwards, the total weight of the harvest of that field can be estimated directly. The crop will usually first be dried and then placed in a granary. When the crop is being put into the granary, it will be carried in sacks or baskets. By counting the number of times the sacks or baskets have to be filled before the entire harvest is in the granary, one can work out how much the harvest weighs. This is done by taking a few sacks or baskets at random, finding the average weight of their contents, and multiplying this weight by the number of times the sacks or baskets were filled.



After being dried, the harvest will be transported to the granary

Example of a production estimate: basket method

A farmer has harvested a sorghum field and brings the crop by cart to his compound to dry. He then stores it in his granary. The enumerator

has arranged with the farmer to be called when the farmer is ready to put the sorghum into the granary. A big basket, filled with roughly the same amount each time, is used to carry the sorghum into the granary. The enumerator counts that the basket has been filled 68 times. This is easy for him to do: he simply puts a mark in his notebook for every basket filled; or, as an aid to memory, he puts one stem of sorghum aside for every 10 baskets filled. (This is what some Moslem farmers do traditionally so farmers might understand that procedure.) Three times at random the enumerator takes a full basket and weighs its contents. He obtains the weights of 16.5 kg, 18.5 kg, and 17.5 kg. The weight of an average filling is then calculated to be $\frac{16.5 + 18.5 + 17.5}{3} = 17.5$ kg. Since the entire crop filled up 68 baskets, the total production of the field can be estimated at $17.5 \times 68 = 1,190$ kg.

If several baskets of different sizes are used, the method can still be applied, by counting the times that each type of basket is filled and weighing a few random samples of each type.

It may ease the work of the enumerator and thus improve the accuracy of the data he obtains if all the farmers are given identical baskets to be used at harvest time.

For an estimate of the weight of the harvest in grains, the farmer should be asked to thresh one of the baskets already weighed so that the weight lost by threshing can be estimated. If the farmer wants to thresh the entire crop before putting it in his granary, the principle remains the same. When writing down the number of baskets, the enumerator should always indicate whether their contents were threshed or not.

If the harvest is brought to the granary a little at a time, it will be difficult for the enumerator to be there each time, but when the farmer is very cooperative and careful, he will usually be able to inform the enumerator how many times he filled his baskets.

11.3 Indirect estimates of crop production

The crop production of a field can also be estimated indirectly. This means that one does not have to consider the entire harvest of the field, but only the harvest of part of the field.

What one does is to mark off part of the field early in the growing season and measure its area. At harvest time, the crops produced on this area are weighed. Knowing this weight and the area on which it was produced, one can calculate the crop yield. As was explained in Chapter 7, the crop yield is the number of kilograms of crop that a field would produce if its area was precisely one hectare.

If one knows the crop yield and the actual area of a field, one can estimate that field's crop production by multiplying the yield by the area.

Two ways of making indirect estimates of crop production are: the sample plot method and the row method. These will now be explained.

Sample plot method

With the sample plot method, one or more squares of known size (the sample plots) are picketed off in the field when the crop is beginning to grow. At harvest time the production of the sample plots is weighed and the crop yield is calculated.

For example: Suppose 12 kg of sorghum are harvested on a sample plot of 10 m by 10 m. The area of the sample plot is $10 \times 10 = 100 \text{ m}^2$. There are 10,000 m^2 in one hectare, so it would take $\frac{10,000}{100} = 100$ of these sample plots to make up a field of one hectare. The crop yield of such a field can be estimated to be $12 \times 100 = 1,200 \text{ kg}$.

The sample plot method can be used in fields that grow only one crop, but is equally suitable in fields that grow mixed crops.

An estimate made with the sample plot method is correct only if the plants in the sample plot performed in the same way as those in the rest of the field - not better, not worse, just the same.

When the location of sample plots is being chosen, it is best to do this at random. One then has a good chance of selecting plots that are representative of the field. There are various ways of locating sample plots at random, but it is beyond the scope of this book to discuss them. The important thing to remember is that whatever method is applied, the same method should be applied in all the fields in the sample.

Row method

For crops sown in rows, the row method may be preferable to the sample plot method. With the row method, a few sample rows are chosen early in the crop season and their area is measured. At harvest time their production is weighed and the crop yield is calculated.

For example: A cotton field is sown in rows 80 cm apart. Early in the season, when the plants are still small enough for the enumerator to walk easily in the field, he counts the number of rows on one side, say Side AB. Suppose there are 94 rows on AB. The enumerator chooses three rows, evenly spaced over the field, but never taking any at the edge of the field. (The edge of a field is seldom representative of a field.) To do this, he divides the number of rows by 4: $\frac{94}{4} = 24$ (rounded off). He then starts walking along AB, counting the rows, and places a picket at the beginning of the 24th row, another picket at the beginning of the 48th row, and another at the beginning of the 72nd row. He then measures the length of each of these rows and places a picket at their other end to mark them. The length of Row 24 is found to be 30 m; that of Row 48 is 45 m, and that of Row 72 is 27 m.

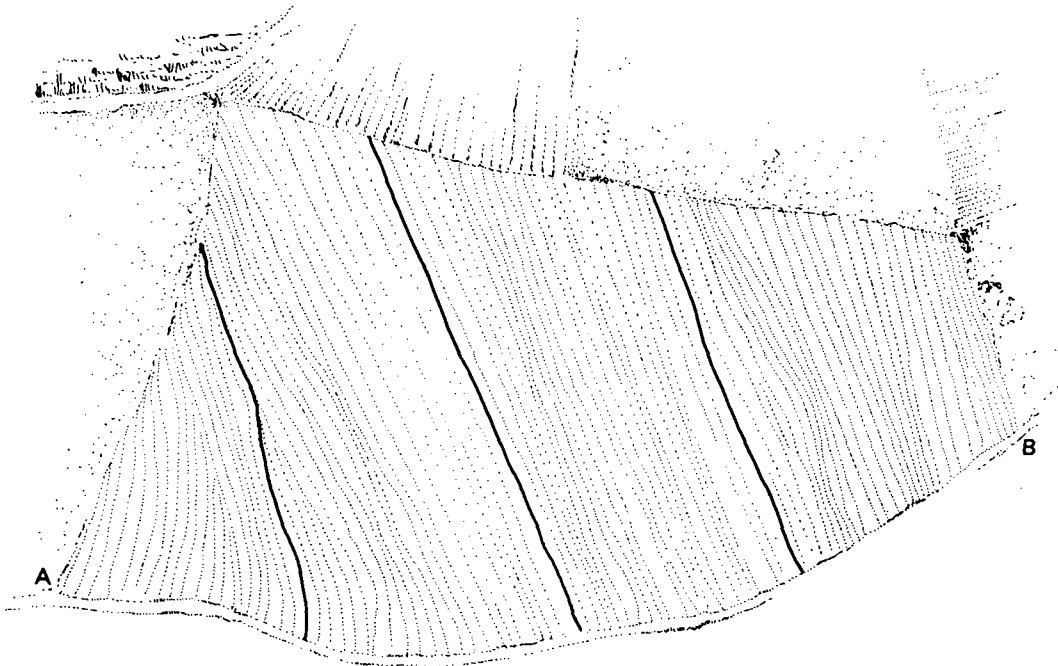

Sample rows in a field

The area represented by these three rows then has to be calculated. The area of each row is found by multiplying its length by the spacing between the rows (80 cm).

For Row 24, the area is $30 \text{ m} \times 0.8 \text{ m} = 24 \text{ m}^2$.

For Row 48, the area is $45 \text{ m} \times 0.8 \text{ m} = 36 \text{ m}^2$.

For Row 72, the area is $27 \text{ m} \times 0.8 \text{ m} = 21.6 \text{ m}^2$.

The total area of the three rows is therefore $24 + 36 + 21.6 = 81.6 \text{ m}^2$.

At harvest time, with the enumerator present, the three sample rows are harvested separately and their harvests are weighed. If the enumerator cannot be present at harvest time, he should make an arrangement with the farmer that the farmer leaves the sample rows and one or two rows beside them untouched. At a later date, the enumerator or the farmer will harvest the remaining rows, taking care to keep the harvest of the sample rows separate from the rest.

If the harvest of the sample rows is found to be 11.7 kg, the crop yield can be estimated to be $\frac{11.7 \times 10,000}{81.6} = 1,440$ kg/ha (rounded off).

Instead of choosing rows evenly spaced over the field, the enumerator may choose the rows at random. The harvesting and weighing methodology remains the same.

The enumerator will ensure the cooperation of the farmer if he actively participates in the harvest of the sample plots or rows. It will help to build a better relationship between the farmer and the enumerator if the enumerator weighs the sample harvest on the spot and immediately informs the farmer of the result.

An important difference between the sample plot method and the row method is that, with the first method, a pre-determined area is harvested, whereas with the second, the area harvested depends on row length and the spacings between rows, which will be different for every field.

Chapter 11 : Questions

- I. The amount of millet produced on a field is to be estimated by the basket method. The farmer and the enumerator both counted 12 large baskets and 18 small baskets. Two large baskets were selected at random and weighed. The first weighed 17 kg, the second 18 kg. The second basket was threshed, which left 12 kg grains. Two small baskets were also selected and weighed. Both were 12 kg.
- Calculate the total harvest of millet on head and in grains.
 - Calculate the percentage of weight lost by threshing.
- II. A field of 1.5 ha has been cultivated with sorghum and cowpeas. The enumerator has to estimate the harvest of the field by the sample plot method. The area of the sample plot is 200 m². It was harvested separately and its production was weighed. The sample plot produced 12 kg of sorghum and 8 kg of cowpeas.
- Calculate the productions of sorghum and cowpeas of the field.
 - A more in-depth study of the sample plot showed that the ratio of the area under sorghum to the area under cowpeas was 2:1. Calculate the yields of sorghum and cowpeas separately.
- III. The yield of a cotton field is to be estimated by the row method. The rows are 0.8 m apart. Four rows were selected, evenly spaced over the field. The lengths of the rows were 150, 175, 162, 138 m. The cotton was picked in two rounds. The first round produced 45 kg from the sample rows; the second 18 kg. Calculate the yield of the cotton field.
- IV. The sorghum production of a field was estimated by the basket method; it was 1,800 kg. The production of a sample plot of 100 m² was 6 kg.
- Calculate the yield of the field.
 - Calculate the area of the field.

In mathematics, a number always represents a precise value. In farm surveys, many of the numbers - obtained by measuring something (a field or the weight of a harvest) or by interviewing a farmer (about his income or how much fertilizer he uses) - are not precise. In a survey, there are many sources of error in obtaining a number. Besides, a number obtained in a survey is not exact but has been rounded off, meaning that it fits somewhere between an upper and a lower limit. The difference between the upper and lower limits diminishes as the measure is made more precisely.

For example: If you weigh a basket of sorghum with a precise scale and read a weight of 18.27 kg, this may mean that the real weight of the sorghum is somewhere between 18.265 kg and 18.275 kg. If you have only a simple scale marked at every kilo, you will read the weight of the sorghum at 18 kg and can only say that the real weight is somewhere between 17.5 and 18.5 kg.

What matters is not so much the size of the error by itself, but how big it is compared to what you are measuring.

For example: If you make an error of 50 grams when weighing an elephant, this error is far less serious than the same error made when weighing a mouse.

In the same way, an absolute error (the difference between the real

weight and the weight read on the scale) of 100 g is more serious when weighing a dish containing about 2 kg of sorghum than when weighing a basket containing 20 kg. In the first case, the relative error (the absolute error divided by the weight read on the scale) is $\frac{100}{2,000} = 0.05$ (5 per cent); in the second case, it is only $\frac{100}{20,000} = 0.005$ (0.5 per cent).

Factors that can influence the precision of the results of data gathering will be discussed below. They include errors in the selection of the sample, errors due to imprecise instruments, errors due to carelessness of the person taking the measurements, and errors that happen when the results are being calculated.

12.1 Sample errors

In most surveys, it is not the entire population that is studied but only a sample - a few elements that are assumed to be representative of the whole population (see Chapter 6). Since a sample is never *completely* representative, the generalizations drawn from the survey of a sample are never completely correct either. A certain margin of error is accepted, however, because of the advantages of saving time and money when gathering the data.

How well a sample represents the population depends upon two factors: how the sample was selected, and how big it is.

Error due to sample selection

A sample is representative of the population only if those aspects of the population being studied are represented in the sample in the same proportion as they exist in the population.

For example: If a sample is being selected to represent the population of a town and the sample is taken from the names listed in its telephone book, only the people with a telephone have a chance of be-

ing selected; so the sample is not representative of the entire population of the town, but only of those owning a telephone.

Size of the sample

The larger the sample, the more representative it is of the population. A perfect representative sample would consist of the entire population! To save time and money, however, the sample is chosen as small as possible, with an expected margin of error that is still acceptable for the objectives of the survey.

12.2 Errors due to instruments

It should always be remembered that a measurement can never be more precise than the tool used to make the measurement.

For example: A dish of sorghum might weigh 2.879 kg but you will only know that if your scale has a mark for each gram. If you use a scale with marks at every 100 grams, you will read the mark nearest to the needle and say that the dish weighs 2.9 kg.

The measuring instruments used in farm surveys (scales, compasses, chains) are rarely very precise. Precise measuring instruments are usually expensive and fragile, and are not really needed in a farm survey.

For example: What is the use of having a chronometer that can register the time up to a fraction of a second if labour-time surveys only register the beginning and end of the work? For this, an ordinary watch will do. It is a different matter in the Olympic Games, where the difference between the gold medal or nothing may lie in tenths of a second.

Another example would be using a measuring chain marked in millimetres to measure a field. The enumerator must decide where the field

begins and ends, and that can easily entail a margin of error of 30 or 40 cm. So what is the use of having a millimetre scale on the measuring equipment?

If precise measurements are required, the cost of buying and using the instruments needed to obtain such measurements will increase. So before it is decided what instruments will be used, the costs and the benefits of more precise measurements have to be compared.

Even the most precise measuring equipment will give wrong readings if it is not properly taken care of. If a compass is dropped, its readings may become unreliable. Measuring tapes thrown in a corner without being rewound will get tangled and may break. Scales that are not oiled or adjusted regularly will give incorrect weights. It is the personal responsibility of the enumerator to take the time to maintain his equipment and to use it carefully.

12.3 Human errors

Another source of error is human error. Nobody works without making a mistake once in a while. It happens to everybody that they look at the wrong number on a scale, or copy a number in the wrong column, or write down the wrong information. This kind of error can be reduced by having regular checks made during data gathering, with several people looking at the data. Some errors will still remain undiscovered but again it is a choice of costs and benefits. Perfect data do not exist! More checks mean better data but also fewer data (from the same number of people) because more time has to be spent on checking.

The director of the unit will decide on a compromise solution to this problem when he designs the survey program and prepares a work schedule for the unit's staff. He will try to get the best possible data with the staff and the funds he has at his disposal.

When an enumerator is measuring something (e.g. weighing a basket of sorghum) he should always remember that if he makes a mistake, he is

wasting his time. Either the mistake will be noticed at the office and his measurement will be rejected, or if it is used, the results will be wrong.

When information is obtained by questioning the farmer, there can be human errors both on the part of the farmer and on the part of the enumerator. The farmer may not recall an event correctly, or may not want to tell the truth, or may misunderstand the question. The enumerator may misunderstand the farmer, write the answer incorrectly or in the wrong place, or write it so sloppily that it will be read incorrectly.



Did I measure 283 m or 313 m?

Human errors can be reduced at no extra cost by using measuring instruments which are very clear and easy to read (e.g. scales with large spaces between the marks), by asking the farmer only simple questions that are easy for him to understand, by avoiding questions about sensitive subjects, and by asking only about facts that the farmer can reasonably remember.

In the data processing, errors can easily be made if the processors touch the wrong key on the calculator. For that reason, many calcula-

tions are done twice to ensure that the results are correct. Common sense is a very desirable trait in data processors as it can help them to detect obvious errors.

12.4 Rounding off

If imprecise figures are used in a calculation, the final result is also imprecise.

For example: If two baskets of sorghum are weighed at 18.6 kg and 20.3 kg, the total weight of the two baskets is $18.6 + 20.3 = 38.9$ kg. If another scale had been used, the baskets might have weighed 18.5 kg and 20.2 kg, with a sum of $18.5 + 20.2 = 38.7$ kg.

When imprecise figures are multiplied, their errors are multiplied as well.

For example: If the dimensions of a rectangular field could be measured precisely, its area could be calculated precisely. Let us say that its length is 105.10 m and its width is 57.60 m. Its area would then be $105.10 \times 57.60 = 6,053.76 \text{ m}^2$. But if measured with a tape marked at every metre, the area would be calculated as: $105 \times 58 = 6,090 \text{ m}^2$.

The boundaries of a field are usually not very precise. Two people going to measure the same field could disagree on exactly where the field begins and ends. In the above example, for instance, the field could easily have been measured as 104 m by 58, and its area would then be $6,032 \text{ m}^2$. Or it might have been measured as 105 m by 57 m; its area would then be $5,985 \text{ m}^2$.

For these reasons, it is usually agreed beforehand that numbers will be rounded off systematically. Only rounded-off numbers are included in the reports and tables of a farm survey. The process of rounding off will be explained by an example.

Example of rounding off

Suppose the yield of a cotton field has been estimated at 1,258.76 kg. If that number is given in a report, the reader will think that the measurements have been taken in a very precise manner, which is not true. The estimated yield may easily be 100 kg more or 100 kg less than the real yield, and it is therefore rounded off to hundreds of kilograms. To do this, consider the digit of the number indicating the hundred (here it is 2). If the digit on the right of it is less than 5, it and all others on the right are replaced by zeros (digits after the decimal point are completely ignored). If the digit on the right of the 2 is 5 or greater than 5, it is replaced by a zero and so too are the other digits to the right, and one unit is added to the 2. The rounded-off result is 1,300 kg, and indeed 1,258 is closer to 1,300 than to 1,200.

With very precise measurements, the result could be rounded-off at units of one kg (1,259 kg) or one tenth of a kg (1,258.8 kg). The general principle is always the same: decide at what level of precision you want to round off (one tenth of a kg, one kg, 10 kg, and so on), think of the rounded numbers at the desired level of precision just above and just below the measured number, and choose the rounded-off number closest to the calculated number.

The procedure of rounding off can be used for different purposes:

- To present data for which a precise number is not known. Here, the numbers are rounded off to the level of precision which *is* known. If the production of sorghum is known to 100 kg, it will be rounded-off to hundreds; if it is known to one tenth of a kilogram, it is rounded-off to tenths of a kilogram. This rounding-off process does not add more errors to the results; it indicates the level of precision of the data.
- To make the data easier to use. Suppose the average number of people in a household has been calculated as 8.7495. The reader does not need such precision and the result is easier to read and to use if it is rounded off to 8.7. This rounding off includes an error ($8.7495 - 8.7 = 0.0495$) which is acceptable to the user.

Chapter 12 : Questions

- I. An enumerator is doing surveys in a village. Part of his task is to make yield estimates by sample plots selected at random. The director of the monitoring and evaluation unit decided that each field should have one sample plot of 40×10 m. The enumerator received a measuring tape with marks at every metre, enough pickets to mark out the sample plots, and a scale with marks at every kilo. He was instructed where to locate the sample plots.
- What types of errors might the enumerator make while marking out the sample plots?
 - What type of error could be reduced if the enumerator could decide to lay out more sample plots while keeping the total sample area of 400 m^2 ?
 - What type of error would increase with more sample plots? Explain your answer.
 - If you were the enumerator and you noticed that one of the sample plots was to be located at a very bad spot in the field, should you choose another location? Explain your answer.
 - At harvest time, the production of the sample plots is harvested and weighed. The production of a sample plot of cowpeas was found to be 20 kg. Calculate the yield of that field.
If you know that the 20 kg are weighed in one batch, what is the maximum error in the yield estimate? What is the maximum relative error?
- II. A rectangular field is known to be 29.56 m long and 19.70 wide (area 0.0582332 ha). An enumerator is to measure this field as an exercise to check whether he understands the principle of measuring fields. He has received a chain which has marks at every metre. The boundaries of the field are very clear so the enumerator will make no errors in starting and ending his measurements.
- What would the enumerator measure if he did a careful job?
 - Calculate the relative errors.
 - Calculate the area from the enumerator's measurements and round off the result.

13.1 Climate

The semi-arid tropics have a climate with high temperatures and a low annual rainfall. There is one rainy season lasting four to eight months. Even during the rainy season, the rainfall is irregular; there is a big rain once in a while and in between there are dry periods.

The main climatic constraint on farming is likely to be lack of water, because the amount of rain is relatively small, and part of it is lost to the crop through runoff. (When it rains, it often rains very hard and part of the water runs off without penetrating into the soil.)

How much water is really available to the plants depends not only on the rainfall, but also on the type of soil (some soils retain water longer than others), on the depth and extent of the plant roots, and on how fast water is lost by evaporation from the soil and through the plants.

Plants suffer during a dry period, but waterlogging (water remains at the foot of the plants) can be equally harmful. Water requirements vary with the type of plant and its stage of development: a plant needs a lot of water while it is growing, and usually only a little when it is maturing for harvest. Before anyone can say whether it has been a good year for rainfall or not, he must know not only how much rain fell, but also how it was distributed over the crop season.

In addition to the irregular, unpredictable timing of each rain, the total rainfall varies greatly from one year to the next. A farmer never knows in advance whether it is going to be a dry year or a wet year, and he can never be sure what is the best time to start sowing.

Data on rainfall, temperatures, humidity, and other climatic factors are recorded at weather stations in various locations in all countries. Because there can be great variations in rainfall over short distances, additional rain gauges are often installed by extension services so that they can know how much rain falls on the fields and when.

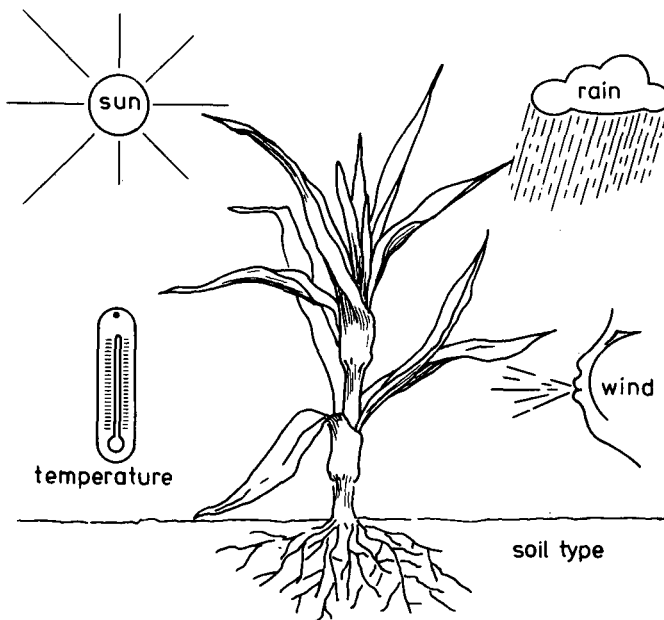

Many climatic factors influence the growth of a crop

13.2 Characteristics of the soil

A plant is greatly influenced by the type of soil in which it is growing. Four soil characteristics, in particular, influence the growth of plants. These are:

- The structure of the top soil;

- The chemical composition of the soil;
- The depth of the soil;
- The topography of the field.

The structure of the top soil

The top soil is the layer of soil in which the roots of plants grow. If the top soil is compact, it will be difficult for the plant roots to penetrate into the deeper parts of the layer and the roots will remain superficial. Plants in compact soils are therefore sensitive to a dry spell because their roots are too shallow to reach the deeper parts, which remain moist longer.

The structure of the top soil can be improved by tillage (ploughing, harrowing, hoeing, and so on) and by turning organic material under into the soil.

The most precise way of learning about a soil is to have a specialist take samples of it and analyze them in a laboratory. But by simply looking at and touching the soil, one can already learn much about it. Sandy soil is made up of particles that are easily separated; clay soil is much more compact, with particles that stick together. Water will run through sandy soils much faster than through clay soils. Clay soils can be very difficult to work for several days after a rain because they become very soft and sticky.

The chemical composition of the soil

The chemical composition of the soil influences plant development because plants withdraw nutrients (food) from the soil. Lack of nutrients in the soil can cause plants to develop poorly. Nutrients that are lacking in the soil can be added by applying chemical fertilizers or manure. Crop rotation also helps. Crop rotation means growing different crops on a field over the years. Different crops take different nutrients out of the soil, and some crops even take nutrients from the air

and add them to the soil. Legume crops, for instance, fix nitrogen in the soil, and nitrogen is one of the main nutrients needed by cereal crops. Crop rotation can include a fallow period (a period in which the fields are not cultivated) to give the soil a chance to rest and allow natural vegetation to help renew the soil nutrients.

The main nutrients found in a good soil are nitrogen, phosphate, and potassium, but many others are present in very small quantities. Fertilizers contain either one nutrient or several nutrients in combination. If the plants are to develop properly and produce a high yield, they must have the specific nutrients they need. If these are in short natural supply, they must be added to the soil in the proper quantities.

The soil depth

If the top soil is not deep enough (if, say, there is a layer of rock close to the surface), the plants will be very sensitive to drought. The shallow soil cannot hold much water and the plants will dry faster during a short dry period than plants in deeper soils will. Shallow parts in a field are usually easy to identify because the vegetation there looks different from that on the rest of the field.

The topography of the field

In a level field, water will usually be distributed evenly over the field. If the field is not level, water will tend to collect in the lower parts and the plants growing there may suffer from waterlogging. Usually the farmer is well aware of this danger and in those lower parts he will plant a crop or variety that can withstand excessive water or even requires it (rice). On the higher, dryer spots, he will grow a different crop or variety. As it is usually not possible for a small farmer to change the topography of a field, choosing a combination of crops well adapted to that field is the best solution.

13.3 Soil erosion

Soil erosion means the loss of the top soil due to the action of water or wind. Where the top soil is not protected by natural vegetation or by a crop, the violent rains frequent in the tropics can cause erosion by washing part of the soil away. Strong winds during the dry season can also cause erosion by carrying off the lighter parts of the soil.

In eroded soils, the smaller soil particles have been washed or blown away and only the bigger particles are left. Nutrients in small particles are more easily available to plants than those in large particles, so it is more difficult for plants to grow in eroded soils. Soils can become so shallow through erosion that the plants do not have enough space for their roots and the field has to be abandoned.

To prevent erosion, the soil should be kept covered (e.g. with the residue of the previous crop and weeds) until the first rains, when the new seed bed can be prepared shortly before it is sown. If early ploughing is desirable, it is better to leave the soil in large clods until the first rains, because a finely tilled soil is more likely to blow away.

Erosion is particularly likely on a slope, because rain water will run downhill, carrying the soil with it. On slopes, measures must be taken to slow down the flow of water. All tillage operations should be done across the slope so that the furrows made by the ploughs and harrows create waterways to hold the flow, while the ridges act as miniature dams.

Engineering solutions, often combining terracing and artificial drainage, are more permanent but require large investments of capital and labour, as well as technical knowledge that a farmer is not likely to possess.

Chapter 13 : Questions

(All pertaining to the area you are working in):

- I. What do the farmers do to improve the structure of the top soil?
- II. In many villages the farmers have names for the different types of soil. Name a few of the more commonly occurring soil types and give a few of their main characteristics.
- III. Does the soil type influence the selection of crops (or varieties) and the yield expectation? Explain your answer.
- IV. What do the farmers cultivate in the lower parts of their fields where waterlogging is frequent?
- V. If farmers take some action to protect their fields against erosion, what do they do? Against which type of erosion is this aimed? Does it help? Explain your answer.

An enumerator working in farm surveys needs a basic understanding of the agricultural operations done by the farmers during the crop season. It is on these subjects that he will be asked to collect much of the information required by the surveys. This chapter will therefore review common farming practices and will explain what information enumerators will probably be asked to gather.

14.1 Land preparation

Before a crop is sown, the land is prepared. This is done for four reasons:

- To loosen the soil so that the roots can grow and so that rain can penetrate more easily;
- To turn organic matter (and sometimes manure or fertilizer) under into the soil;
- To control the growth of weeds;
- To shape the seedbed (into ridges, beds, or mounds).

Land can be prepared in three ways:

- By hand (using a spade, hoe, rake, etc.);
- By animal-drawn implements (a plough, harrow, etc.);
- By heavier tractor-drawn implements.

Land preparation by hand loosens the top soil and gets rid of the weeds.

Implements drawn by animals and tractors can penetrate more deeply into the soil and can do a better job of preparing the land. They can really plough it.

Ploughing means turning over the top soil and burying all the weeds and organic matter. The depth of ploughing depends on the type of traction and the way the plough is adjusted. Ploughing should always be deep enough to loosen the soil where the roots will develop.

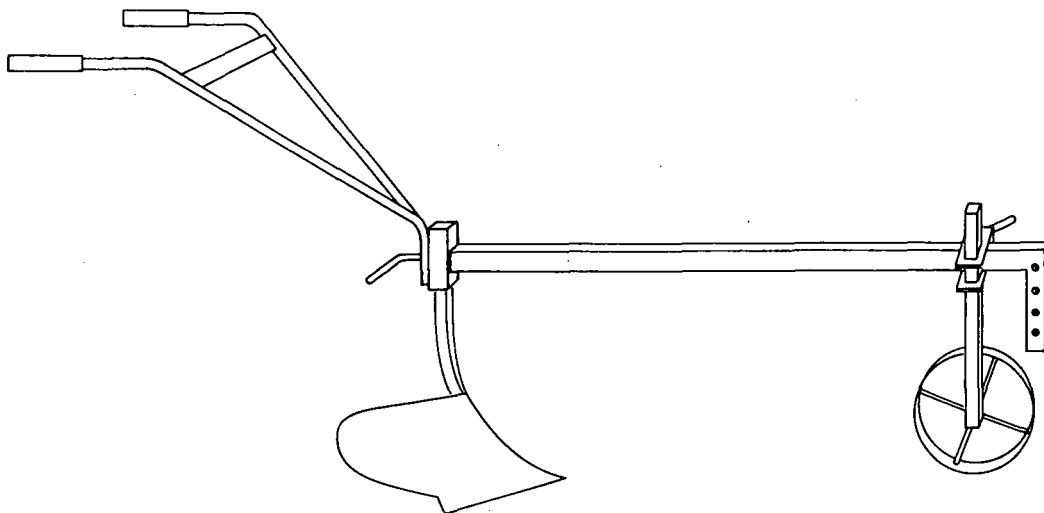

A plough for animal traction

Sometimes, when land is being prepared, the soil is not turned over but is simply scratched open and weeded. This is done with a cultivator - an instrument with heavy tines - or with simple hand tools.

After being ploughed, the land is usually harrowed. Harrowing means breaking up the clods of soil left after ploughing. A good seedbed requires small clods of soil.

The timing of ploughing is important. If there is a long period between ploughing and sowing, weeds will grow again and the land may have to be ploughed a second time just before sowing. The best time to plough is shortly after a rain, when the soil is moist but not too wet. Ploughing a field when it is too dry can cause small particles of the top soil to blow away. Such wind erosion can have serious consequences for farming.

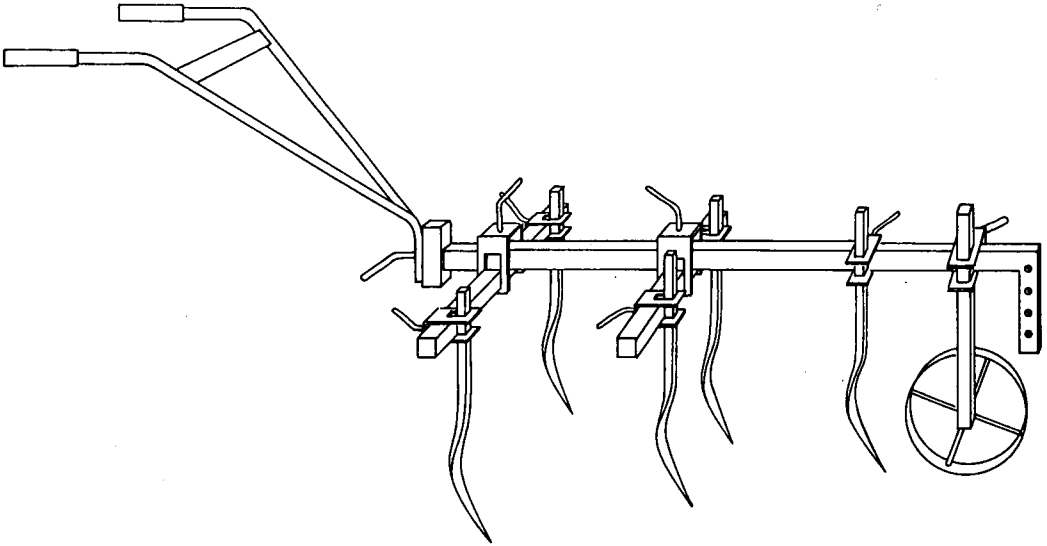

A cultivator

On slopes, the direction of ploughing is important. Rain falling on slopes runs downhill and can wash away part of the top soil. Such water erosion is less likely to happen if ploughing is done across the slope, not down it.

On the topic of land preparation, enumerators will probably be asked to collect the following information:

- How was the land prepared?
- What tools were used in preparing the land?
- When was land preparation done?
- If the field is on a slope, do the furrows made by the plough run across the slope?
- How deep are the furrows?

The Food and Agricultural Organization of the United Nations classifies ploughing by the depth of the furrows. It uses the following classes:

- Light ploughing : furrows less than 15 cm deep;
- Average ploughing: furrows 15 to 25 cm deep;
- Deep ploughing : furrows 25 cm or more deep.

14.2 Sowing

A field can be sown in various ways:

- Broadcasting: The farmer throws the seeds around him while walking up and down the field;
- Sowing in plant holes: The farmer makes a hole in the ground with a hoe, puts a few seeds in the hole, and closes it;
- Sowing in rows: The farmer sows in plant holes which are regularly spaced along a straight line. The line to be followed and the spacing of the holes can be marked on a sowing cord, or the lines can be scratched with a cultivator. Sowing in rows is necessary if weeding or ridging is to be done later by animal traction;
- Sowing with a seeder: A seeder is an implement drawn by an animal or a tractor. It sows seeds in rows. The result is the same as manual sowing in rows, but a seeder sows much faster.

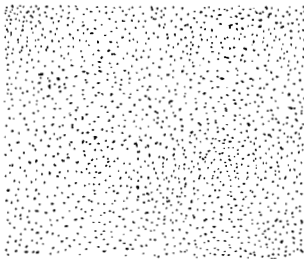

Broadcasting

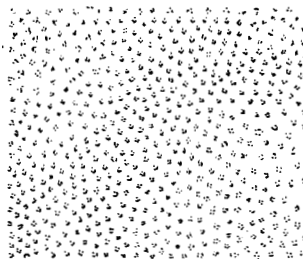

Sowing in plant holes



Sowing in rows

The crop production that can be expected from a field depends greatly on the variety of seed that is sown. Each seed variety has its own characteristic resistance to drought, diseases, and insects, and its own time to come to maturity.

The timing of sowing can have a great influence on crop production. Ideally, sowing should be timed so that the crop comes to maturity when the length of day and the rainfall pattern best suit the seed variety that has been sown. But sowing, of course, cannot be done until the rains have started.

If too many seeds are sown on a field, the plants will have to compete with one another for space, water, and soil nutrients, and the crop production will be low. On the other hand, if too few seeds are sown, the few resulting plants will leave more space for weeds to grow and this will also reduce production. The ideal plant density - the number of plants per hectare - is somewhere between these two extremes.

On the topic of sowing, enumerators will probably be asked to collect the following information:

- How was the sowing done?
- What tools were used?
- When was the sowing done?
- What seed variety was sown?
- What is the plant density?

14.3 Crop maintenance

Crop maintenance means all the activities undertaken by the farmer to control the environment of the plants and help them grow. Crop maintenance includes:

- **Thinning:** If too many plants are growing in a field, some of them are pulled out of the ground so that the remaining plants do not have to compete with one another;
- **Weeding:** The plants should not have to compete with weeds for the nutrients and water in the soil. Weeds should be pulled out or cut off as soon as they emerge. A crop seldom recovers fully if weeding is delayed;
- **Cultivating:** This means loosening the surface of the soil to allow water to penetrate to the roots, and to minimize the evaporation of water from the soil;
- **Ridging:** Piling a ridge of soil up against the base of the plant rows places more soil around the roots and makes it easier for excess water to drain away in the furrows. Tied-ridging involves making cross-ridges in the furrows, to trap the water.

All these activities can be done by hand, or with a hoe, or by equipment

drawn by animals or tractors. Some cultivators have a standard frame to which different sized tines can be fitted. If animals are used for crop maintenance, a yoke larger than that used for ploughing is needed so that the animals do not trample the plants. The methods and equipment used by the farmer will influence the quality of his work and should therefore be observed carefully.

The timing of the operations is also important. Often a farmer will combine his first weeding with thinning and cultivating. But if he waits too many days between planting and his first weeding, or between his first and second weeding, this will have a harmful effect on the crop performance.

On the topic of crop performance, enumerators are likely to be asked to gather the following information:

- What crop maintenance operations did the farmer do?
- What tools or equipment did he use?
- How many days were there between the various operations?
- Did the crop develop well?

The many observations that enumerators will be asked to make during crop maintenance will be helpful later on to explain differences in yields obtained by neighbouring farmers.

14.4 Application of fertilizer

Fertilizer stimulates plant growth by adding nutrients to the soil or by replacing nutrients taken away by the previous crop. Fertilizer can be either manure or chemicals. Manure has the added advantage of improving the structure of the soil because of its organic nature. The quantity of manure available to the farmer depends on the size of his herd and whether the farmer collects the manure. If the cattle are kept together, it is easy for the farmer to collect the manure and put it on his fields. Often, however, the cattle roam around freely and the manure is lost.

Other organic matter can be used to bring nutrients to the soil. This may be either in the form of compost (mixture of organic residues which have been left to decompose) or green fertilizer (a crop grown to be ploughed into the soil).

If chemical fertilizers are used they will supply nutrients but will not improve the soil structure (which can still be improved by ploughing the weeds into the soil). There are 'straight' fertilizers, with only one nutrient (e.g. nitrogen or phosphate), and 'compound' fertilizers which contain more than one nutrient (e.g. ammonium phosphate contains both nitrogen and phosphate). A 'complete' fertilizer contains nitrogen (N), phosphate (P), and potassium (K). The quantity of each nutrient contained in a complete fertilizer is marked on the sack as a percentage of the weight, in the order N-P-K. A sack containing 100 kg of fertilizer and labelled 18-24-18 contains 18 kg of nitrogen, 24 kg of phosphate, and 18 kg of potassium. The remaining 40 kg include traces of other chemical components (which also help plant growth), filler substances, and impurities. Usually, agronomists will recommend a minimum fertilizer application, depending on the crop that is grown and on local soil conditions.

It is not always true that a higher dose of fertilizer automatically results in a higher yield. If lack of soil nutrients is the most limiting factor for the growth of the plant, a higher fertilizer input will result in a higher yield. At a certain level of fertilizer input, however, other aspects can become the most limiting factors (e.g. crop maintenance) and a higher dosage of fertilizer will then not lead to a higher yield. To decide what quantity of which type of fertilizer it is best to apply, one should think not only of the plant requirements and the soil properties, but also whether the cost of the fertilizer will be offset by the expected increase in production.

The method of applying fertilizer influences its effectiveness. Fertilizer can be broadcast on the soil and then ploughed into it, so that the nutrients are available to the seeds as they start growing. Or it can be applied around the plant or between rows during weeding.

Also of importance is the timing of the fertilizer application. In a plant's early stage of development, it grows quickly and needs many nutrients. Fertilizer has to be applied at that stage. If fertilizer is applied earlier, before the plant is well started, there is a chance that the fertilizer will be used more by the weeds around the plant than by the plant itself. If it is applied later, when the plant no longer needs so many nutrients, the fertilizer will have little effect and its cost will not be compensated for by a bigger harvest.

On the topic of fertilizer application, enumerators will be asked to obtain the following information:

- What type of fertilizer was used and what was its concentration?
- What quantity was applied?
- How was it applied?
- When was it applied?

14.5 Crop protection

Crops can be damaged in many ways, but many measures can be taken to protect them. The seeds can be given a chemical treatment which keeps them in good condition until the growing process starts. Later, the plants can be sprayed to protect them from insects, either as a preventive measure or after the first signs of insect infestation. Later still, the harvested grain can be treated before it is stored in the granary so that it keeps longer.

Many types of insecticide are available to protect crops, each of them having a specific action. Sometimes an insecticide will kill only one type of insect and will not hurt another type. The project's agronomist will determine which insecticide is needed in the local situation. If he does not come to the fields regularly during the growing season, the enumerator may be asked to observe the crops for signs of insect damage. If he sees any, he will probably be asked to send a few damaged plants to the agronomist, who will then identify the insect and prescribe the right insecticide.

Although correct insect control does not increase the yield, poor insect control can greatly reduce the yield. Enumerators will probably be asked to follow the insecticide spraying closely. The things they should observe are:

- The type and quantity of insecticides used (on the seeds, on the crop, and on the harvest);
- The dates of application (a crop often needs more than one treatment).

Other crop damage which enumerators will be asked to observe is that caused by:

- Diseases;
- The weather (long period of drought);
- The topography (low part of the field flooded);
- Cattle, birds, wild animals;
- Fire.

The enumerator should carefully observe any such damage and take notes of what caused it. Later, if a certain farmer's production is below expectation, the enumerator's notes will help explain why.

14.6 Cropping pattern

A farmer's cropping pattern is the way he distributes his different crops over his fields in one growing season. The crops can be grown in 'pure stand' (one crop growing on the field) or in 'mixed cropping' (two or more crops growing on the field at the same time).

Mixed cropping may mean growing alternate rows of each crop (intercropping), mixing crops within a row, or broadcasting (mixing the crops purely at random). Sometimes, the second crop is planted only after the first one is well established.

Mixed cropping has the advantage of lowering the risk to the farmer in case one of the crops fails. Once in while, the rainfall in the growing season may be such that a certain crop fails completely; but there is a

very small chance that two crops with different rain requirements will fail at the same time.

Another advantage is that insect populations will be smaller in mixed cropping than in pure stand because the quantity of plants of one type together will be less, which makes them less attractive to the insects.



Intercropping

When the growing season is long enough, two crops can sometimes be grown one after the other on the same field in the same year.

On the topic of the cropping pattern, enumerators will be asked to obtain information on:

- What crops are grown by the farmer?
- Which crops are grown in pure stand?
- Which crops are grown in mixed cropping?
- What type of mixed cropping does the farmer practise?

14.7 Crop rotation

Crop rotation is the succession of different crops grown on the same field over the years. A good crop rotation helps preserve or restore soil fertility, because different crops use different nutrients and leave different residues. A rotation may include food and cash crops, grass and fodder crops (crops which are used to feed livestock), or simply leaving the land fallow for a few years (allowing the natural vegetation to grow back). If legume crops (peas and beans) are included in a rotation, they will take nitrogen from the air and fix it in the soil, thus helping to replace the nitrogen removed by a previous cereal crop.

On the topic of crop rotation, enumerators will be asked to obtain information about each field. The questions are likely to be:

- What crop or crops are being grown on the field?
- What crop or crops were grown in the previous season?
(Sometimes, enumerators are asked to gather crop rotation data about even earlier seasons.)
- Are the crop residues burned, grazed, or ploughed under?

Chapter 14 : Questions

Questions: (All questions pertaining to your area.)

- I. Describe the techniques the farmers use to prepare their land.
- II. For each of the main crops grown in your area, describe the sowing method used by the farmers.
- III. Crop maintenance activities were discussed in 14.3. For each of these activities, state whether it is done by the farmers in your area.

15.1 Introduction

Economics is the study of the production, distribution, and consumption of goods and services. Agricultural economics is the study of those goods and services as they apply to agriculture.

An agricultural economist estimates what a farmer earns from his fields by calculating the value of the harvest and subtracting all the expenses which the farmer had to make to obtain that harvest. If the economist does this for all the fields of a farm, and for all the other activities of the farmer and the members of the household (raising livestock, selling handicrafts, and so on) he can calculate the total income of the household.

15.2 Some terms used in agricultural economics

Some of the terms used in agricultural economics are:

- Agricultural production: The quantity of a crop harvested by a farmer;
- Yield: The agricultural production expressed in kilograms per hectare;
- Gross margin of a crop: The money value of the crop after the costs that have been incurred to produce the crop have been deducted;
- Net profit of a farm: The sum of the gross margins of all the crops

- grown on the farm in one crop season;
- Net household income: The net profit of the farm plus the net income derived from other activities (e.g. livestock, off-farm work);
 - Input: A general term for the elements that are put into the production of a crop (e.g. fertilizer, insecticide, labour) or into the production of goods (e.g. fabric, buttons, and thread to make a shirt);
 - Production cycle: The time it takes to produce goods, from getting the inputs together to finishing the goods;
 - Crop season: The time it takes to grow a crop, from preparing the land to harvesting the crop. In the semi-arid tropics, the crop season and the rainy season coincide.

15.3 Costs and investments

When calculating the income of a farmer (or a manufacturer), one has to distinguish between a cost and an investment. The difference between the two will be shown by examples.

Examples of costs versus investments

A tailor makes shirts for sale. To be able to make the shirts faster and better than by hand, he buys a sewing machine. This sewing machine will last for many years. The money he spends to buy the machine helps him to earn more in those years than he would otherwise earn. The machine is an investment. But this investment alone is not enough for the tailor to make the shirts; he still has to buy fabric, buttons, and thread. The money he pays for these things are costs.

In the same way, when a farmer spends money to buy a cow that he will keep for several years while it produces calves, he is making an investment. The money he spends each year to feed the cow and care for it are costs.

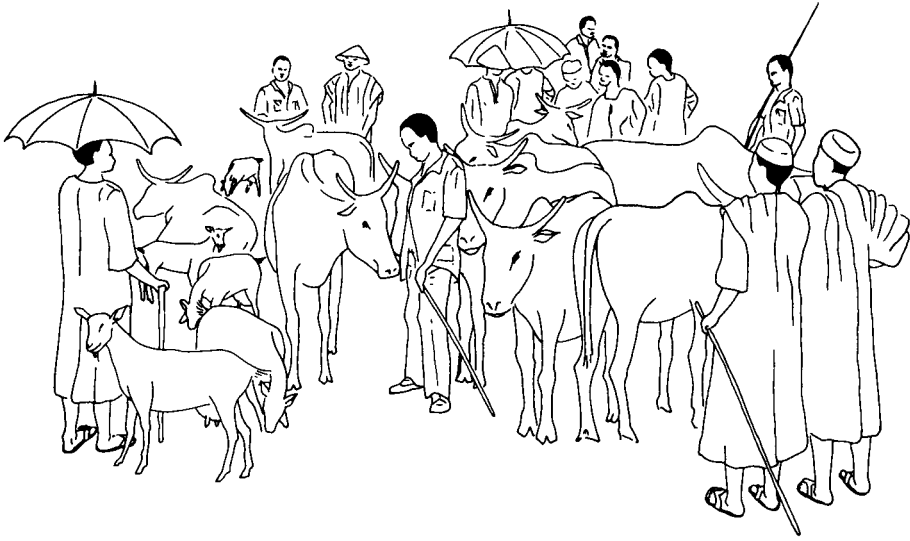

Farmer buying a cow

A cost can be defined as the amount paid for goods which are used for only one production cycle or one crop season.

An investment can be defined as the amount paid for goods which last longer than one production cycle or one crop season.

15.4 Costs in cash and in kind

A crop cannot be cultivated without some costs being incurred. The farmer will have to buy tools to sow and cultivate the crop and he may have to buy seeds and fertilizer; the amounts he pays for these things are called costs in cash. If he takes the seeds out of his own granary, this is called a cost in kind. It is a true cost in producing the crop because the seeds could have been sold for a certain price and therefore have a certain value. Another example of a cost in kind is a basket of sorghum given to somebody in return for his help in harvesting the sorghum crop; this, too, is a cost in producing the crop, because it could have been sold at the market for a price.

The farmer's own labour, although it is also an input in kind, is usually not counted as a cost. In general, it is not possible for a subsistence farmer to find a job other than working on his farm (except during the harvest periods), so he cannot sell his labour and no price can be put on it.

Most costs in kind can be converted into costs in money. Both represent costs in growing a crop. Nevertheless, a farmer, when asked about his costs, may forget to mention costs in kind because he did not pay any money for them.

15.5 Direct and indirect costs

The direct costs of a crop are those costs that can be allocated directly to that crop.

For example: When a farmer buys cotton seed or some fertilizer or insecticide for his cotton, the money is spent only on the cotton and is a direct cost to the cotton crop.

Indirect costs are costs which are made, not for one specific crop, but for the farm as a whole.

For example: When a farmer buys a hoe or pays to have his plough sharpened and then uses the hoe or the plough on all his crops, these costs cannot be attributed to one specific crop; they are indirect costs.

15.6 Credit costs

A basic problem in farming is that before anyone can earn money, he must first spend some. Banks or individuals can lend money to a farmer. They provide the money on the condition that the farmer pays back more than he borrows. The difference between the two amounts is a payment the farmer makes for the right to use the money. This is called the interest

on the loan. Usually, interest is expressed as a percentage of the amount borrowed over a certain period of time. The longer it takes the farmer to pay back the loan, the more interest he has to pay.

For example: If a farmer borrows 100,000 CFA at an interest rate of 10 per cent a year (which means 10 CFA interest for each 100 CFA borrowed) and pays it back after one year, he must repay at the end of the year:

Interest	$\frac{100,000 \times 10}{100} = 10,000$
Loan	<u>100,000</u>
Total repayment	110,000 CFA

If he pays back the loan after two years, he must pay the yearly interest of 10,000 CFA at the end of the first year and another 10,000 CFA at the end of the second year, as well as repaying the loan. His total payment is 120,000 CFA.

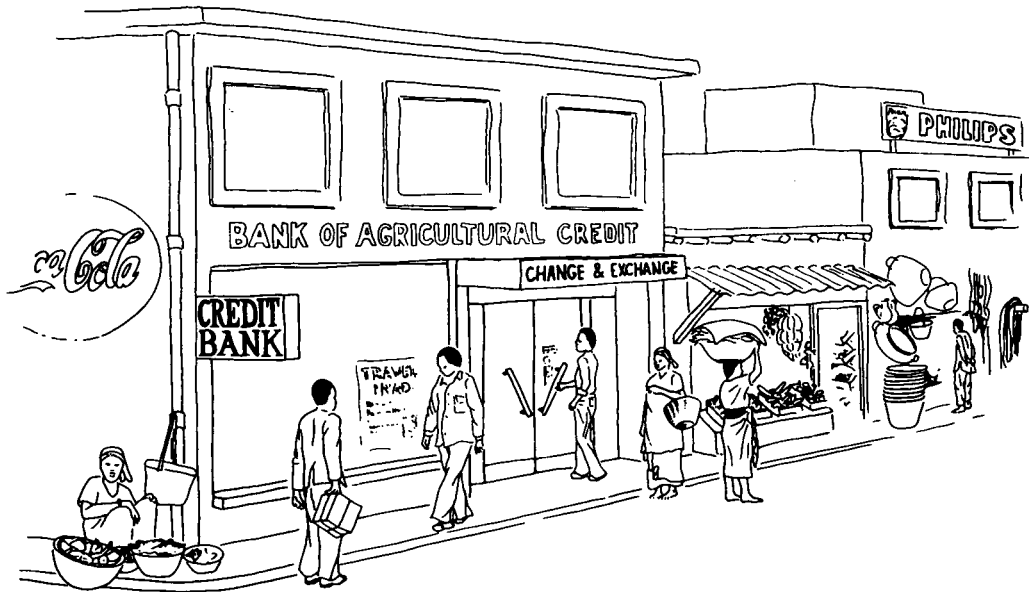

Bank of Agricultural Credit

In the reverse situation, an individual can lend money to a bank. If he

has some money he does not immediately need, he can put it into a savings account. He allows the bank to use his money until he decides that he wants it back. In exchange, the bank will pay him interest. The total amount of interest he receives depends upon the amount of money he lent the bank and the length of time he left it there.

The same system works when borrowing in kind. A farmer can obtain a tine of sorghum from a neighbour or a merchant when his own supply is finished, on the condition that he pays back two tines right after the next harvest, three months later. Calculated in volume, it would seem that the interest rate is 100 per cent for the three months, which would be an extremely good deal for the lender. But one should not forget that the price of sorghum right after the harvest, when two tines are given back, is much lower than three months before harvest when sorghum is scarce. So, if money had been involved, the interest rate would have been lower.

For example: A farmer borrows one tine of sorghum just before harvest, when the price is 1,400 CFA. After harvest, when he pays back two tines, the price of a tine is only 950 CFA. So, in fact, he repays a total of $950 \times 2 = 1,900$ CFA for the loan of 1,400 CFA. He has paid $1,900 - 1,400 = 500$ CFA in interest. The interest rate is $\frac{500 \times 100}{1,400} = 35.7$ per cent for three months, which, although it is not the 100 per cent as in kind, is still very high.

A common situation in agricultural development is for a farmer to receive goods on credit, which he repays in cash. The farmer often receives agricultural inputs or equipment direct from a credit unit; after the harvest he pays back the price of the goods, plus interest, in cash. Agricultural credit systems give several types of loans (at different interest rates) depending on the duration of the loan. The duration and the corresponding interest rate often depend on what the loan will be used for.

The main types of agricultural loans are:

- Short-term credit (less than one year): This is credit to finance the costs of inputs such as seeds and fertilizers, which will be used in

one crop season. This credit must be repaid shortly after the harvest. Usually, the credit is given in kind rather than in cash;

- Medium- and long-term credit: If the farmer wants to buy some equipment for animal traction (= make an investment), he needs credit which he can repay over several years because the equipment is too expensive for him to repay from the benefits of only one harvest. The time allowed for repayment is often the same as the time the equipment is expected to last. A medium-term loan is usually for 2 to 5 years, a long-term loan for more than 5 years. These forms of credit are often given in cash so that the farmer can purchase the equipment himself. Sometimes, if the farmer cannot repay the loan on time, the credit unit has the right to take the equipment back.

The interest rates of medium- and long-term credit are usually lower than those of short-term credit.

15.7 Cost of investments

If money is invested in a tool that lasts for several years, the value of the tool declines as it gets older. This loss in value is called depreciation. It is the depreciation, not the price for which the tool was bought, which is subtracted as a cost when the farm income is being calculated. For simplification, one assumes that the loss in value is the same every year.

For example: If a tool is bought for 3,000 CFA and will be worth nothing after being used for six years, the depreciation is $\frac{3,000}{6} = 500$ CFA a year.

If a farmer invests in agricultural equipment bought on credit because it is too expensive for him to pay for in cash, he will have to pay interest on the loan. There are then two categories of costs for that equipment: the depreciation and the interest charged by the credit unit.

A third type of cost tied to investments is the cost of repair and maintenance to keep the equipment in good shape.

Example of calculating the cost of an investment

A farmer borrows 15,000 CFA. to buy a plough. Normally a plough can last for 10 years, after which it cannot be used for ploughing but it can still be sold to a blacksmith for 4,000 CFA. (The blacksmith uses most of the iron to make small agricultural tools.) So in 10 years the plough will have lost $15,000 - 4,000 = 11,000$ CFA in value. The depreciation is therefore $\frac{11,000}{10} = 1,100$ CFA a year. The interest cost is 10 per cent of the loan. If the loan is repaid over 10 years, the interest cost varies between 1,500 CFA (in Year 1) and 150 CFA (in Year 10). The average interest cost over the 10 years is therefore $\frac{1}{2}(1500 + 150) = 825$ CFA a year. Repairs to the plough average 200 CFA a year. The total cost of the investment is therefore $1,100 + 825 + 200 = 2,125$ CFA a year.

15.8 Labour unit

Spending money on improved seed varieties, fertilizer, and insecticides will not increase crop production if the fields are not carefully prepared and kept properly weeded. Whether this work is done well and at the proper time depends on the number of workers in a household and their capacity for work.

Not all workers have the same capacity for work. A child of twelve can do useful work, but he cannot yet do the heavy work that a man can. A woman, in addition to working in the fields, fetches water and cooks the meals, so she does not work in the fields as long as the men do. It is therefore difficult to make a direct comparison of the work that can be done by different households.

For example: Suppose there are two households. In the first, the workers are three adult men, two adult women, and one child. In the second household the workers are one adult man, one adult woman, and four children. The two households cannot possibly do the same amount of work, even though each has six workers.

When data on workers are being analyzed, a system often used is one that expresses the workers in units of labour.

For example: Such a system might express the working capacity of one adult man as one labour unit, the working capacity of one adult woman as 0.8 of a labour unit, and that of a child as 0.5 of a labour unit.

The values given to labour units depend on the sex and age of the workers and may differ from place to place, depending on such matters as what work is expected of the different members of the household.

The total of labour units in a household is known as the labour force. This can be calculated and compared with the labour force of other households.

The amount of work required for a crop is expressed in man-days. One man-day is the amount of work that can be done by one labour unit in one day.

A great deal of research has been done to find out how much labour is needed to grow a crop properly. Much of this research has been published in the form of labour films. These express the number of man-days required to cultivate a crop on one hectare throughout the crop season. Labour films have been made for many different crops and for many different farming conditions.

Chapter 15 : Questions

- I. A farmer owns a small stall at the market place for the sale of products from his farm. He employs a young man for this purpose at a wage of 4,000 CFA a month. The stall was built at a cost of 5,000 CFA and will last for five years, after which it will need rebuilding. The farmer has to pay a market tax of 1 CFA per kg of produce sold.
- What investments did the farmer make to operate his stall?
 - What are the yearly costs of these investments?
 - If 10 kg of millet are sold, what are the direct costs (in cash and in kind)?
 - What indirect costs are incurred if, in 6 months, 4,500 kg of produce are sold?
- II. A farmer cultivates peanuts on a fairly large scale, as well as cereals for household consumption. He has a pair of oxen which he uses as draught animals for crop production. They graze freely but when they are working, they receive some sorghum. To obtain a high yield, he uses a large quantity of fertilizer on each crop. Most of the labour required for the peanut crop is provided by the members of the household, although at harvest time, extra labour is hired. The hired labour is paid with a share of the harvest.
- List the direct costs of the cultivation of peanuts. Indicate whether these costs are in cash or kind.
 - List the indirect costs, also indicating whether they are in cash or kind.
- III. A blacksmith in a village makes small agricultural tools and repairs equipment for animal traction. He has a small smithy, which he built 3 years ago with his own money at a cost of 40,000 CFA. It will last for 8 years if maintained properly (cost of maintenance: 1,000 CFA a year).

He bought his forge and his tools 3 years ago with a loan of 300,000 CFA. He has to repay the loan in 10 years, which is the time the forge and tools will last; they will be worth nothing

after that time. The interest rate on the loan is 10 per cent a year.

The blacksmith employs an apprentice for 1,000 CFA a month.

- a) What are the blacksmith's investments worth now, 3 years after he began?
- b) What are the total costs of his investments in Year 4?
- c) How much interest does he have to pay in Year 4?
- d) Suppose the blacksmith receives 800,000 CFA each year for his work. The cost of the materials he uses is 600,000 CFA a year. What is his annual income?

A farming household usually has several sources of income, but in subsistence farming most of the income is earned through the cultivation of crops.

In this chapter, we shall explain how to calculate a farm's net profit from crop cultivation. This is done in two steps:

- The first step is to calculate separately for each field, the gross margin of its crop (or mixture of crops in case of intercropping). The gross margin is the money value of the crop after the direct costs (costs which can be attributed directly to that crop) have been deducted. If the same crop is grown on different fields, the calculations are still done separately for each field because crops grown on different fields grow under different conditions (other soils, different timing of operations, different quantities of fertilizer etc.);
- After all the calculations have been done for all the fields of the farm, the second step is to add up the gross margins of all the crops and then to subtract the indirect costs (costs which cannot be attributed to one specific crop, but which were made for the whole farm). This gives the net profit from crop cultivation.

16.1 Gross margin of a crop

To calculate the gross margin of a crop, we first calculate the money

value of the crop by multiplying the production in kilograms by the price per kilogram. We then subtract all the direct costs of that crop.

The direct costs of a crop may include the following:

- Seeds: If seeds are bought, the cost is the price paid for them. If seeds are taken from the stock left from the previous harvest, the cost used is the price one would have to pay for seeds at the local market;
- Fertilizer: If chemical fertilizer is used, the cost is the price paid for it. If manure is used, no cost can be allocated because manure is not sold and therefore has no price;
- Insecticide: The cost is the purchase price of the quantity used on the crop. The cost of a sprayer (cost of hiring, or, if owned, the cost of depreciation and maintenance) can only be considered a direct cost if the sprayer is used on one crop only. If used for more than one crop, the cost of the sprayer must be considered an indirect cost;
- Labour: This cost is the money paid to hired workers or the money value of that part of the crop given to them in return for their work. Usually no cost is allocated to household labour;
- Credit: If a loan has been taken to finance the inputs for one specific crop, the cost is the interest paid on the loan.

Example of calculating gross margins

In 1980, a household grew four crops in pure stand on four different fields. Information about the costs and value of their production is presented in Table 16.1.

The value of the cotton they produced is $1,300 \text{ kg} \times 54 \text{ CFA/kg} = 70,200 \text{ CFA}$.

The direct costs of the cotton were:

- Seeds: Given by marketing board;
- Fertilizer: $140 \text{ kg} \times 35 \text{ CFA/kg} = 4,900 \text{ CFA}$;
- Insecticide: $12 \text{ l} \times 500 \text{ CFA/l} = 6,000 \text{ CFA}$;

Table 16.1. Costs and values of crop production of a household in 1980

Crop	Area cultivated (ha)	Inputs									Production		
		Seeds		Fertilizer		Insecticide		Hired labour		House. lab.		Quantity kg	Price CFA/kg
		Quantity kg	Price CFA/kg	Quantity kg	Price CFA/kg	Quantity l	Price CFA/l	Days	Price per day	Days Man	Days Woman		
Cotton	1.1	45	Free*	140	35	12	500	8	1 basket cotton = 5 kg	110	8	1300	54
Sorghum	1.1	15	From stock	-	-	-	-	-	-	85	-	800	62
Cowpeas	0.3	8	95	-	-	2	500	-	-	5	8	230	79
Maize	0.2	5	95	40	35	-	-	-	-	5	-	150	57
Total	2.7												

* Provided by marketing board

- Labour: The day price of a hired worker is one basket of cotton weighing 5 kg. Expressed in money, it is $5 \text{ kg} \times 54 \text{ CFA} = 270 \text{ CFA}$. The cost of 8 days of hired labour is therefore $8 \times 270 = 2,160 \text{ CFA}$.

Total direct costs: $4,900 + 6,000 + 2,160 = 13,060 \text{ CFA}$.

The cost of hiring the sprayer (500 CFA) is an indirect cost because it was also used on the cowpeas. There are no credit costs; all inputs were paid for in cash. The gross margin from cotton is $70,200 - 13,060 = 57,140 \text{ CFA}$.



A farmer spraying

The gross margin for sorghum is calculated in the same way, except that the market price for the seeds is used because the farmer took the seeds from his granary. The value of the sorghum crop is $800 \text{ kg} \times 62 \text{ CFA/kg} = 49,600 \text{ CFA}$. The cost of seeds was $15 \text{ kg} \times 62 \text{ CFA/kg} = 930 \text{ CFA}$. The gross margin of the sorghum crop is $49,600 - 930 = 48,670 \text{ CFA}$.

The gross margin for cowpeas is:

$(230 \text{ kg} \times 79 \text{ CFA/kg}) - (8 \text{ kg} \times 95 \text{ CFA/kg}) - (2 \text{ l} \times 500 \text{ CFA/l}) = 16,410 \text{ CFA}$.

The gross margin for maize is:

$$(150 \text{ kg} \times 57 \text{ CFA/kg}) - (5 \text{ kg} \times 95 \text{ CFA/kg}) - (40 \text{ kg} \times 35 \text{ CFA/kg}) = 6,675 \text{ CFA.}$$

In these calculations of the gross margins, the market prices of seeds, fertilizer, and crop were used, so the margins can vary if the prices change. An important part of an enumerator's work is therefore to monitor the prices at the local market so that reliable data on prices are available.

Sometimes, when two (or more crops) are cultivated on the same field, it may be difficult to separate the costs made for each crop (direct costs) or even to identify the area on which each crop grows. In that case, all the crops on one field are taken together and the gross margin is calculated for that combination of crops.

The gross margin per field shows which field is the most profitable. (In our example, it is the cotton field.) Gross margins also allow other comparisons to be made. These concern land, labour, and inputs.

16.2 Gross margin per hectare

If the farmer does not have as much land as he could cultivate and wants to obtain the highest possible income from the land he has, he wants to know which crop will bring him the highest gross margin per hectare. In our example, cowpeas and maize were grown only on small plots of land. To be able to compare them with the other crops, we have to calculate the gross margin each crop would have had if it had been cultivated on one hectare. This is done by dividing the gross margin by the crop area.

$$\text{Cotton : } \frac{57,140 \text{ CFA}}{1.1 \text{ ha}} = 51,945 \text{ CFA/ha}$$

$$\text{Sorghum: } \frac{48,670 \text{ CFA}}{1.1 \text{ ha}} = 44,245 \text{ CFA/ha}$$

$$\text{Cowpeas: } \frac{16,410 \text{ CFA}}{0.3 \text{ ha}} = 54,700 \text{ CFA/ha}$$

$$\text{Maize} : \frac{6,675 \text{ CFA}}{0.2 \text{ ha}} = 33,375 \text{ CFA/ha}$$

Cowpeas have a higher gross margin per hectare than the other crops, so the farmer may want to grow more cowpeas next year. This will only make sense, however, if there is a market for the extra cowpeas.

16.3 Gross margin per man-day

If a farmer has more land than he and the members of his household can cultivate, he will be interested in crops that bring a high gross margin per day of work put into them. This is calculated by dividing the gross margin of a crop by the total number of man-days that were needed to produce that crop. (A man-day is one day of work by one unit of labour.) The labour force of the household in our example is a man, his wife, and one grown-up son. The father and son each represent one labour unit; the wife represents 0.8 labour unit.

$$\text{Total man-days on cotton} = (110 \times 1) + (8 \times 0.8) = 116.4 \text{ man-days.}$$

Gross margin per man-day from:

$$\text{Cotton} : \frac{57,140 \text{ CFA}}{116.4 \text{ man-days}} = 491 \text{ CFA/man-day}$$

$$\text{Sorghum} : \frac{48,670 \text{ CFA}}{(85 \times 1) \text{ man-days}} = 573 \text{ CFA/man-day}$$

$$\text{Cowpeas} : \frac{6,410 \text{ CFA}}{(5 \times 1) + (8 \times 0.8) \text{ man-days}} = 1,439 \text{ CFA/man-day}$$

$$\text{Maize} : \frac{6,675 \text{ CFA}}{(5 \times 1) \text{ man-days}} = 1,335 \text{ CFA/man-day}$$

Cowpeas and maize have higher gross margins per man-day than the other crops, partly because only a minimum amount of labour was put into them. Calculated per man-day, sorghum was more profitable than cotton, because it required less labour.

16.4 Gross margin per unit of cost

If the farmer has very little money to spend on inputs, he may want to know which crop gives a higher return per unit of money spent on inputs. This is calculated by dividing the gross margin by the direct costs. The ratio thus obtained - called the benefit/cost ratio - has no unit of measurement because it is a ratio of two quantities of the same kind.

The gross margins per unit of cost are:

$$\text{Cotton} : \frac{57,140 \text{ CFA}}{13,060 \text{ CFA}} = 4.38$$

$$\text{Sorghum} : \frac{48,670 \text{ CFA}}{930 \text{ CFA}} = 52.33$$

$$\text{Cowpeas} : \frac{16,410 \text{ CFA}}{1,760 \text{ CFA}} = 9.32$$

$$\text{Maize} : \frac{6,675 \text{ CFA}}{1,875 \text{ CFA}} = 3.56$$

The benefit/cost ratio for sorghum is much higher than for any of the other crops because very little money was spent on it.

16.5 Gross production value

The gross production value from crop cultivation is the sum of the gross margins of all the fields of the farm. For the hypothetical household in our example, this is: $57,140 + 48,670 + 16,410 + 6,675 = 128,895$ CFA.

If we want to compare this household's gross production value with that of their neighbours, who farm a different sized area of land with a different labour force, we can calculate for each household the gross production value per hectare. For our hypothetical household, this is: $\frac{128,895 \text{ CFA}}{2.7 \text{ ha}} = 47,739$ CFA/ha.

Another way to compare the two households is to calculate their gross production value per unit of labour (not counting temporary hired workers). For our hypothetical household, this is:

$$\frac{128,895 \text{ CFA}}{1 + 1 + 0.8 \text{ units of labour}} = 46,034 \text{ CFA/unit of labour.}$$

16.6 Net profit from crop cultivation

The gross production value does not yet represent what the household has earned in cash and in kind. To obtain this figure, we must calculate the net profit. We do this by subtracting all the indirect costs from the gross production value.

Indirect costs include:

- The maintenance and depreciation of agricultural tools and equipment;
- The feeding and care of animals for animal traction or transport and their loss or gain in value;
- Any interest on equipment or draught animals bought on credit.

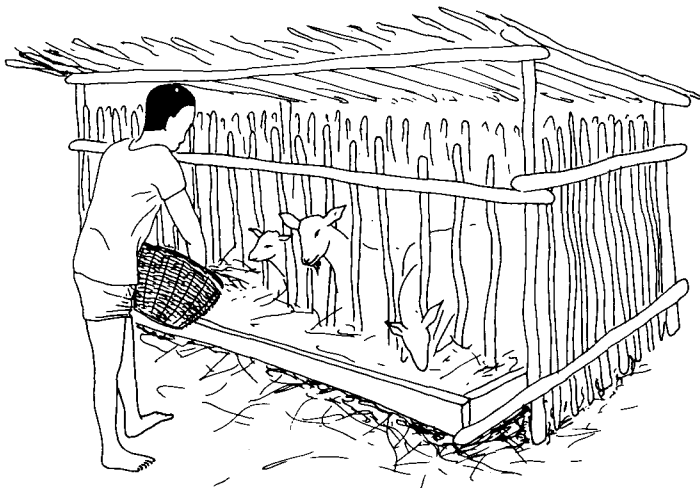

A farmer feeding his goats

One should not forget that if these costs can be clearly allocated to one crop, they are considered direct costs. In that case they have already been included in the calculation of the gross margin per crop.

Our hypothetical household has obtained a gross production value of 128,895 CFA on 2.7 ha. They have the usual hand tools, as well as a

donkey and a plough. They have been careful to maintain their equipment properly. Their indirect costs will be calculated below.

- Cost of hand tools: There are two types of costs involved with small agricultural hand tools. Some tools last more than one crop season so their cost is their yearly depreciation. Other tools last only one crop season and have to be bought new each year; their cost is their purchase price. Our hypothetical farmer owns a shovel, which cost 500 CFA and will last two crop seasons; its cost is its depreciation, which is 250 CFA a year. At the beginning of 1980, he bought three hoes for a total of 630 CFA and two knives for a total of 700 CFA; these will last for only one crop season. So, in 1980, the total cost of hand tools was: $250 + 630 + 700 = 1,580$ CFA.

- Cost of hiring an insecticide sprayer, which was used on the cotton and the cowpeas, was 500 CFA.

- Cost of plough: The plough cost 19,000 CFA and was paid for in cash in 1980. It should last 10 years, after which it can be sold to the smith for 2,000 CFA. The yearly depreciation is: $\frac{19,000 - 2,000}{10} = 1,700$ CFA. The cost of repairs to the plough in 1980 was 3,150 CFA.

- Cost of donkey: The donkey was bought for 17,000 CFA cash and is expected to work for eight years, after which it can be sold for 3,000 CFA. The yearly loss in the value of the donkey is: $\frac{17,000 - 3,000}{8} = 1,750$ CFA.

The costs of taking care of the donkey were:

Veterinary care:	1,000 CFA
Food	: <u>1,750 CFA</u>
Total	: 2,750 CFA

The total indirect costs are:

Cost of hand tools	:	1,580 CFA
Hire of sprayer	:	500 CFA
Depreciation plough	:	1,700 CFA
Repairs to plough	:	3,150 CFA
Loss in value of donkey:		1,750 CFA
Care of donkey	:	<u>2,750 CFA</u>
Total		11,430 CFA

The net profit of the household is therefore $128,895 - 11,430 = 117,465$ CFA. This does not mean that the farmer has 117,465 CFA in his pocket. The 117,465 CFA merely represents the value of what the household earned from crop cultivation.

Part of this amount was spent on investments for the farm. The plough, for instance, was bought that year for 19,000 CFA and only 1,700 was depreciated, so 17,300 CFA of the money earned that year has been invested in the plough. In addition, most of the crops produced have to be reserved to feed the members of the household. The amount of money that the farmer can really spend is therefore much less than the net profit of his farm.

The net profit of a farm cannot simply be compared with the net profit of a neighbouring farm, which may be very different (more land, more workers, different crops). This would not be a fair comparison. A better way is to compare their net profits per unit of land, per unit of labour, or per man-day of labour. In our example, the net profit of 117,465 CFA means that the household earned:

$$\text{on 2.7 ha} \quad : \quad \frac{117,465 \text{ CFA}}{2.7 \text{ ha}} = 43,506 \text{ CFA/ha}$$

$$\text{with 2.8 units of labour:} \quad \frac{117,465 \text{ CFA}}{2.8 \text{ units of labour}} = 41,952 \text{ CFA/unit of labour}$$

$$\text{in 217.8 man-days} \quad : \quad \frac{117,465 \text{ CFA}}{217.8 \text{ man-days}} = 539 \text{ CFA/man-day}$$

Chapter 16 : Questions

- I. A household consists of 12 persons, 8 of whom work on the farm. The farm has an area of 5 ha, of which only 4.3 ha are cultivated. Table 16.2 summarizes information on the household's crop production in 1981.
- a) Calculate the gross margin of each field. The seeds were taken from the granary and can be valued at the average market prices shown in Table 16.3.
 - b) In 1981 the household wanted to acquire more land but this was not possible because of the dense population of the area. Given this fact, which gross margin would you use to compare different fields? Do the required calculations.
 - c) Do you think that if the communal fields were changed into private fields or vice versa, would this lead to a higher total gross production value of the farm? Explain your answer.
 - d) The inputs of fertilizer and insecticide are financed by a credit organization. In 1982, however, this will no longer be possible and farmers will have to pay cash for these inputs. In that year, our farmer has only 8,000 CFA to spend on inputs. On which crop do you think he would economize first? Explain your answer.
 - e) The farmer has a pair of oxen and the necessary equipment which he uses to cultivate most of the fields. The oxen were purchased for 60,000 CFA (paid for in cash) and can be sold after 5 years for 120,000 CFA if the farmer takes proper care of them; this will cost him 5,000 CFA a year. The equipment cost 50,000 CFA and after 9 years it can be sold to the smith for 5,000 CFA. It requires some maintenance (e.g. sharpening the plough), which costs 3,000 CFA a year. Calculate the yearly cost of the animal traction.
 - f) The yearly cost of hand tools and interest on a loan for the purchase of agricultural equipment amounts to 4,500 CFA. Calculate the net profit of the farm.

Table 16.2. A household's production figures in 1981

Field number	Communal fields						Private fields				
	1	2	3	4	5	6	Woman 1	Woman 2	Son 1	Son 2	Son 3
Crop(s)	Sorghum	Sorghum/Cowpeas	Millet/Maize	Maize	Cotton	Sorghum	Peanuts	Cowpeas	Sorghum	Millet/Maize	Rice
Area (ha)	.8	.5	.7	.5	.3	.2	.2	.2	.3	.3	.3
Inputs:											
Seeds (kg)	6	3/3	2/13	12	5	1	15	5	2	1/4	20
Fertilizer (kg)	80	10	- -	40	45	-	-	-	-	- -	-
Insecticide (l)	-	-	- -	-	6	-	-	-	-	- -	-
Hire sprayer CFA					500						
Hired labour (days)	10	- -	- -	-	5	-	-	-	-	- -	5
Production (kg)	400	200/100	0 0	400	450	60	120	160	240	120/90	600

143

Table 16.3. Prices of crops and inputs

Product	Sorghum	Millet	Maize	Cotton	Cowpeas	Peanuts	Rice	Fertilizer	Insecticide	Labour
Unit	kg	kg	kg	kg	kg	kg	kg	kg	l	day
Price*/unit (CFA)	62	65	55	45	75	95	70	45	560	350

* Average market price

17.1 Net profit from livestock

Subsistence farmers in the semi-arid tropics almost always raise some chickens or other poultry and keep a few goats or sheep; richer farmers may own some cattle. The farmers earn a certain amount of income from their livestock.

In the net profit from livestock, there are two components: income in cash (from the animals sold) and income in kind (the gain in weight and therefore in value of the animals, and the birth of new animals). How the net profit from livestock is calculated will be explained by an example.

Example of calculating net profit from livestock

At the beginning of the year, a farmer has a herd of 10 sheep worth 30,000 CFA. The sheep graze for their feed and receive no veterinary care. During the year, the farmer sells 2 sheep for a total of 4,000 CFA and buys 3 new ones for a total of 5,000 CFA. At the end of the year, he has a herd of 15 sheep (including 4 new-born), which are worth 35,000 CFA.

His net profit from sheep-raising is:

Value of herd at end of year	35,000 CFA
- Value of herd at beginning of year	<u>-30,000 CFA</u>
= Increase in value of herd	= 5,000 CFA
+ Money received from selling 2 sheep	+ 4,000 CFA
- Money spent on buying 3 sheep	<u>- 5,000 CFA</u>
= Net profit from sheep-raising	= 4,000 CFA

But the farmer does not have 4,000 CFA in his pocket. He actually spent more on buying sheep than he received from selling them (1,000 CFA). Here, the farmer is using his sheep as a savings bank, in which he invests money in good times so that he can draw upon his reserve in bad times by selling some sheep.

In the above example, the net profit from livestock was calculated for one calendar year. Other periods can also be used, say one month or one agricultural season.



A farmer with his herd of cattle

The survey forms on which enumerators will gather data about income from

livestock will usually be set out as tables rather than as questionnaires. Tables make it easy to calculate, on the form itself, how much the farmer spent on, or received from, raising livestock. At regular intervals (say once a year) an inventory of all the livestock owned by the farmer can be made. If the market prices of the various animals are known, the value of the herd can be calculated.

The reason why the net profit from livestock is calculated is to make it possible to compare this net profit with that from crop cultivation, and thus to compare the relative importance of the two activities. If raising livestock represents a major source of income for the farmers in a project, the project manager may require information about the income derived from each type of animal.

A good way to compare one farmer's net profit from livestock with that of a neighbouring farmer is to compare their ratios of net profit to invested money.

Example of calculation of net profit/invested money

A farmer raises sheep and goats with the following results over a survey period of two years.

Herd at the beginning of period 10 sheep and 3 goats.

Herd at the end of period: 14 sheep (including 5 new-born) and 4 goats (including 1 new-born).

Transactions during the 2 years: 1 sheep bought, 2 sheep sold.

Average value of the animals throughout the year:

(To keep the example simple, price variations due to age and weight are not considered.)

Sheep 4,000 CFA

Goat 3,000 CFA

Costs:

500 CFA for medication for goats

1,000 CFA for medication for sheep

The net profit from the herd is:

Value of herd at end of period	$14 \times 4,000 + 4 \times 3,000 =$	68,000 CFA
- Value of herd at beginning of period	$10 \times 4,000 + 3 \times 3,000 =$	<u>49,000 CFA</u>
= Increase in value of herd		19,000 CFA
+ Money earned from sales of livestock	$2 \times 4,000 =$	8,000 CFA
- Money spent for purchase of livestock	$1 \times 4,000 =$	4,000 CFA
- Cost of medication for herd		1,500 CFA
= Net profit from the herd		21,500 CFA

The net profit from livestock is 21,500 CFA, of which 19,000 CFA has been invested in livestock. This income was earned with an investment of 49,000 CFA (value of herd at beginning of period). The ratio net profit per invested CFA is $\frac{21,500 \text{ CFA}}{49,500 \text{ CFA}} = 0.4$, which is quite high.

The farmer may also want to know whether he obtained a higher income from the goats or the sheep, in relation to the money he invested in them. He must then calculate the gross margin from the goats and sheep separately.

Gross margin from sheep

Value at end of period:	$14 \times 4,000 =$	56,000 CFA
- Value at beginning of period:	$10 \times 4,000 =$	<u>40,000 CFA</u>
= Increase in value of sheep:		16,000 CFA
+ Money earned from sales of sheep	$2 \times 4,000 =$	8,000 CFA
- Money spent on purchase of sheep	$1 \times 4,000 =$	4,000 CFA
- Cost of medication for sheep		1,000 CFA
= Gross margin from sheep		19,000 CFA

Gross margin from goats

Value at end of period:	$4 \times 3,000 =$	12,000 CFA
- Value at beginning of period:	$3 \times 3,000 =$	<u>9,000 CFA</u>
= Increase in value of goats:		3,000 CFA
- Cost of medication for goats		500 CFA
= Gross margin from goats		2,500 CFA

The gross margin per invested CFA for sheep is $\frac{19,000 \text{ CFA}}{40,000 \text{ CFA}} = 0.48$ and for goats $\frac{2,500 \text{ CFA}}{9,000 \text{ CFA}} = 0.28$. It can therefore be concluded that raising sheep was more profitable than raising goats for the two years of the survey.

17.2 Net profit from trade and other activities

When a buyer pays a trader 100 CFA for a tin of sardines, the trader does not 'earn' all of the 100 CFA, because earlier he himself had to spend money, let us say 75 CFA, to buy that tin of sardines. So even though he now puts 100 CFA in his pocket, his profit (what he really earns and can spend as he wishes) is only:

$$100 - 75 = 25 \text{ CFA}$$

But in reality things are more complex, because the trader has more expenses than just buying the merchandise he has in stock. He had to build or rent a shop and he has to transport his goods regularly to the shop. He might pay a boy to serve in the shop when he is away. He will have to pay merchants' tax and the credit costs on any loan he took out to set up his stock.

The money he receives for the goods he sells, minus the cost of the purchase of those goods, forms his gross margin from trade. All his other business expenses must be deducted from his gross margin. The amount that is left is his net profit from trade, which is his true profit.

A trader often buys fairly large quantities of goods, which he then sells to people a little at a time. To find out the amount he earns from this buying and selling, a record has to be kept of his purchases and sales. If this information is required by a survey, the enumerator will have to visit the trader quite often while the trader still remembers all the details.

Example of calculating net profit from trade

In a hypothetical household, the wife of the farmer has a little shop in the village. She sells matches, cigarettes, soap, fuel, and batteries. Her trading activities in January 1980 are summarized in Table 17.1.

Once a month, she goes to a nearby town by bush taxi to buy new stock. Those trips cost her 2,000 CFA each time. She must also pay 600 CFA a month to rent her shop, and 400 CFA a month for merchants' tax.



A trader

To calculate her net profit from trade, we first calculate her gross margin for each type of good. We then add up all these gross margins, from which we subtract all indirect costs. The amount we thus obtain is her total net profit from trade.

The gross margin for each type of good is the difference between the price they were sold for and the price they were bought for. For

Table 17.1. Summary of a woman's trade in January 1980

Product	Stock at beginning (1-1-1980)		Trade in January 1980				Stock at end (31-1-1980)	
	Quantity	Value CFA	Purchases		Sales		Quantity	Value CFA
			Quantity	Value CFA	Quantity	Value CFA		
Cigarettes	12 packets 5 pieces	2,450	49 packets	9,800	61 packets 5 pieces	14,700	-	
Matches	8 boxes	40	205 boxes	1,025	193 boxes	1,351	20 boxes	100
Soap	-	-	30 boxes	3,750	24 boxes	3,600	6 boxes	750
Batteries	8 pieces	400	56 pieces	2,800	63 pieces	3,465	1 piece	50
Fuel	20 litres	2,500	140 litres	17,500	144 litres	23,040	16 litres	2,000

cigarettes, the sales were 14,700 CFA. Those cigarettes were obtained partly by purchase (9,800 CFA) and partly from stock (2,450 CFA). The gross margin from cigarettes is therefore $14,700 - 9,800 - 2,450 = 2,450$ CFA. In reality, she received more money than this because she sold out of stock; this had already been paid for in an earlier month.

The 192 boxes of matches, which were sold for 1,351 CFA, were taken from the 205 boxes bought in January. The purchase price of a box of matches was $1,025 \div 205 = 5$ CFA, so the 193 boxes were bought for $193 \times 5 = 965$ CFA. The gross income from the sale of matches is $1,351 - 965 = 386$ CFA. Part of this money was spent to increase the stock of matches from 8 to 20 boxes.

For soap, the gross margin is: $3,600 - 3,000 = 600$ CFA, the purchase price of one box being $3,750 \div 30 = 125$ CFA. For batteries, the gross margin is: $3,465 - 3,150 = 315$ CFA, the purchase price of one battery being $2,800 \div 56 = 50$ CFA. For fuel, the gross margin is: $23,040 - 18,000 = 5,040$ CFA, the fuel being purchased for 125 CFA per litre.

The total gross margin of the shop is the sum of the gross margin of each product: $2,450 + 386 + 600 + 315 + 5,040 = 8,791$ CFA.

The expenses the woman has in running the shop (indirect costs) are:

Rent:	600 CFA
Transport costs:	2,000 CFA
Taxes:	<u>400 CFA</u>
Total	3,000 CFA

The net profit from the shop for January 1980 is therefore:
gross margins - indirect costs = $8,791 - 3,000 = 5,791$ CFA.

The same principles apply if a trader sells something he (or she) has made or processed in some way.

For example: A woman who sells cooked rice or local beer must cover her costs for rice or cereals, wood for the fire, and so on. (If she

uses part of the crop of the farm, that should be valued at its market price.) Supplies which she gathers in the bush (fruits, wood) can be considered free, since usually no value is placed on labour.

Whatever goods are bought or sold, the transactions can all be recorded in a table such as Table 17.1.

Chapter 17 : Questions

I. The son of a farmer breeds sheep. On 1 January 1981, he owned 40 sheep. During the year, he sold 10 sheep for a total price of 30,000 CFA. On 31 December 1981, he still had 40 sheep and the value of the herd was the same as on 1 January. The sheep forage for most of their food under the watchful eye of a little boy, who receives some sorghum every now and then (total 200 kg a year). In the dry season, the sheep are given 20 kg of sorghum a month for 4 months to keep them healthy. The average price of sorghum is 50 CFA per kg. Veterinary care is given when needed, which costs 2,500 CFA a year. Taxes of 30 CFA per head must be paid on the sheep owned on 31 December.

What net income did the son earn from breeding sheep in 1981?

II. A woman processes peanuts into peanut sauce, which she sells at the market. She uses 1 kg of peanuts for the amount of sauce that she can sell per market day (which is once every 3 days). The peanuts cost her 75 CFA per kg. From her sales, she earns 350 CFA per market day. To process the peanuts into peanut sauce, she needs a cooking pot, which lasts for one year and costs 730 CFA. She buys wood for 600 CFA once every 12 days. At the market, she has to pay the market tax, which is 10 CFA every market day.

Calculate:

- a) The woman's yearly income from this activity, assuming 122 markets a year;
- b) Will her income change if she grows the peanuts herself on her private field?

18 CONSTRAINTS ON CHANGES IN FARMING PRACTICES

When a project wants to make changes in traditional farming practices, it must first find out what changes the farmers will accept and what changes they will reject. One of the main objectives of farm surveys is to obtain this information.

Before any changes are introduced, the project must first consider four matters:

- The physical environment;
- The technical feasibility of possible changes;
- The economic return on new techniques;
- The social acceptability of the changes.

18.1 Physical environment

A farmer knows the soils of his fields and knows that their quality can vary, even over short distances. Being aware of this, he grows different crops on different soil types.

A project cannot introduce new crops or new varieties of crops that do not take these differences in soils into account, otherwise the farmers will reject the changes.

18.2 Technical feasibility

If a change in farming practices requires special inputs or equipment, the change is technically feasible only if the inputs or equipment can be made available to the farmers at the proper time.

New farming techniques that the farmers must learn are technically feasible only if there is some one who can teach the farmers the new techniques.

If the project is considering introducing new equipment that cannot be repaired by local craftsmen, the equipment is technically not feasible unless the craftsmen can be taught how to repair it.

18.3 Economic return

When farming practices are being changed, the farmers will usually be asked to spend more money or time on the cultivation of their crops. They will only be willing to do this if the new practice gives them a bigger harvest. The change must earn them more than it cost them, even in a bad year when harvests are disappointing, otherwise they will reject the change.

If an improved variety of crop is likely to give a bad harvest in a poor year - worse than the traditional variety would give - the farmers will reject the new variety. If they feel that they run the risk of not producing enough food to feed their families, they will not accept the change.

If a new farming practice is a very expensive one (such as the introducing of animal traction), good credit facilities must be available to the farmer, otherwise he will be unable to accept the change.

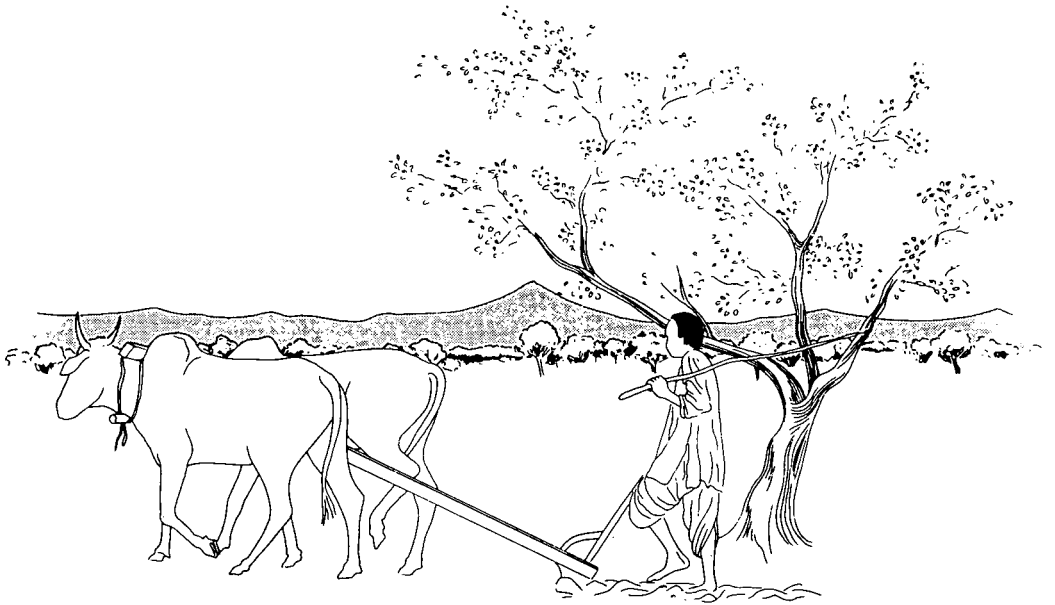

Farmer using animal traction

18.4 Social acceptability

Food is grown to be eaten. If a farming household does not like the taste of a new variety of food crop, they are not going to grow it. The crop is not socially acceptable to them.

Similar problems can arise with varieties that do not keep well, or are difficult to pound into flour, or take a long time to cook.

People who live in the same region usually have the same tastes, so if they do not like a certain crop, they will not be able to sell it at the local market because their neighbours will not like it either.

Some crops are grown for more than one purpose. Long-stemmed sorghum, for instance, is grown not only for food; its straw is used to feed cattle, to make fences around a garden, or as firewood. An agronomist may want to introduce short-stemmed sorghum because its plants use the nutrients in the soil to make grains, not straw. Short-stemmed sorghum

will thus produce more food. The farmer might reject it, however, because he sees the lack of straw as a disadvantage.

18.5 Conclusions

For all these reasons, a project should not introduce changes until it has carefully considered the traditional way of life and the traditional way of farming. Only then can it know what changes the farmers will accept and what they will reject. From long experience, farmers in the semi-arid tropics have developed a way of farming that gives them the best possible results in their circumstances. They will be reluctant to change this way of farming unless they are very sure that a new practice will mean a true improvement. They cannot risk making experiments because their whole livelihood is at stake.

For this reason, a project should introduce changes gradually, building on the traditional way of farming, not changing it abruptly. When the farmers have seen that slight changes are indeed improvements, they will be more willing to accept more radical changes. In this way, a project can do what it is intended to do - and that is to give the farmers and the members of their households a better way of life.

Chapter 18 : Questions

I. An extension project is promoting a new variety of sorghum. On trial fields, this variety yielded about twice as much as a traditional variety under average rainfall conditions and it equalled the yield of a traditional variety under unfavourable rainfall conditions. To obtain a high production, however, the crop must be weeded more often than traditionally and weeding must be done to a stricter schedule. It also requires a rather high dose of fertilizer.

What factors do you think might prevent the adoption of this new variety by the farmers in your region?

II. A farm economist has calculated that oxen traction is financially attractive for a farmer. Although the initial investment is high, after 5 years of work the oxen can be sold for a price that pays for all the costs of the investment in oxen and equipment and gives a profit of 25 per cent. After the farmer has learned how to handle the oxen, the cost of maintaining the equipment and the cost of the extra food and veterinary care required by the oxen will be counterbalanced by the increase in farm production.

What factors do you think might prevent the adoption of oxen traction by the farmers in your region?

ANSWERS TO THE QUESTIONS

The questions in some of the chapters pertain to the area you are working in, or ask your opinion on some matter. No answers are given to these questions. You are advised to discuss such questions with your supervisor or with agricultural extension agents.

Chapter 6

- I. a) In the first survey, all the farmers growing cash crops; in the second survey, all the farmers in project area
b) Yes
- II. a) 6,250 households
b) 11,000 CFA
c) 550,000,000 CFA
- III. a) A shortage of 150,000 tons
b) 800 kg

Chapter 7

- I. a) 9.4 persons per household
b) Range: 16 persons per household
c) Yes
- II. a) Village B
b) Village B

- III. a) 17 kg
- b) 1,700 kg

Chapter 8

- a) Average with animal traction : 71,385 CFA
- Range with animal traction : 77,500 CFA
- Average without animal traction: 47,100 CFA
- Range without animal traction: 51,700 CFA

Chapter 9

- I. No
- II. 80 per cent
- III. a) 15,000 CFA; 120,000 CFA
- b) 8 or 0.125
- c) 300 per cent
- IV. b) Average: 69 CFA
- Range : 24 CFA

Chapter 10

- I. 84 m²
- II. The angles and the lengths of the sides depend on the approximation
- III. b) 2.9 ha (rounded off)

Chapter 11

- I. a) 426 kg on head; 284 kg in grain
- b) 33 per cent
- II. a) 900 kg sorghum; 600 kg cowpeas
- b) 900 kg/ha sorghum; 1,200 kg/ha cowpeas
- III. 1 ton

- IV. a) 600 kg/ha
b) 3 ha

Chapter 12

- I. a) Sample errors, errors due to instruments, human errors
b) Sample errors
c) Errors due to instruments, human errors
d) No
e) 500 kg/ha; 12.5 kg/ha; 0.025
- II. a) 29.5 m; 19.5 m
b) 0.002; 0.01 (rounded off)
c) 0.058 ha

Chapter 15

- I. a) 5,000 CFA
b) 1,000 CFA
c) 10 CFA and 10 kg millet
d) 24,500 CFA
- II a) Fertilizer (cash)
Hired labour (kind)
b) Cost of agricultural tools and any depreciation and maintenance
of agricultural equipment (cash).
Sorghum for oxen (kind)
- III. a) 235,000 CFA
b) 21,000 CFA
c) 57,000 CFA
d) 131,000 CFA

Chapter 16

- a) 17,328 CFA; 19,039 CFA; - 845 CFA; 19,540 CFA; 12,390 CFA; 3,658
CFA; 9,975 CFA; 11,625 CFA; 14,756 CFA; 12,465 CFA; 38,850 CFA

- b) Gross margin per ha; 21,660 CFA/ha; 38,078 CFA/ha; - 1,207 CFA/ha; 39,080 CFA/ha; 41,300 CFA/ha; 18,290 CFA/ha; 49,875 CFA/ha; 58,125 CFA/ha; 49,187 CFA/ha; 41,550 CFA/ha; 129,500 CFA/ha.
- c) A change from communal fields to private fields will increase the gross production value of the farm
- d) Cotton
- e) 1,000 CFA
- f) 153,281 CFA

Chapter 17

- I. 12,300 CFA
- II. a) 13,300 CFA