

10

MODELLING TO A PURPOSE

J. C. Zadoks* and R. Rabbinge†

**Laboratory of Phytopathology, Agricultural University, Wageningen,
The Netherlands*

*†Department of Theoretical Production Ecology, Agricultural University,
Wageningen, The Netherlands*

I. Introduction	231
II. Models in Crop Protection	232
A. Models	232
B. The Modelling Process	233
C. Objectives of Modelling	234
D. Examples of Epidemiological Models	235
III. The Host Crop	236
A. Coupling of Models	236
B. Epidemiological Aspects	236
C. Injury-Damage Relationships	237
D. Simulating the Farmer's Situation	238
IV. Practical Applications of Simulation	
Models	239
A. 'Managerial Models'	239
B. Decision Making	240
C. Optimisation	241
V. Long-term Perspectives	241
A. Crop Management Models	241
B. Centralised and Decentralised Models	242
VI. Integrationistic Science	243
References	243

I. INTRODUCTION

This last chapter tries to grope with the future of mathematical modelling of crop disease. We have not attempted to review the literature objectively. Some literature reviews and textbooks have appeared during the last few years on the use of simulation and models in plant protection (Jeger and Rabbinge, 1983; Ruesink, 1976; de Wit and Goudriaan, 1978; Kranz and Hau, 1980; Jeffers, 1978). These and the foregoing chapters give an introduction to the methods and background of modelling and simulation in crop

protection. The present essay renders the personal views of the authors on the future of modelling as applied to crop protection. Although these views may be biased, the authors feel that they serve to combine the dual objectives of scientific pursuit and public service.

II. MODELS IN CROP PROTECTION

A. Models

An inherent feature of biological science is the conceptualization of complex systems into levels of organization from lower levels such as molecules, organelles and cells to higher levels such as communities, populations and ecosystems (Loomis *et al.*, 1979; Zadoks and Schein, 1979). In this hierarchy, each level exhibits a characteristic behaviour that results from integration of sublevel processes under influences from the external environment.

In crop protection research the mechanistic basis for such a behaviour is being explored by reductionistic techniques, by seeking to isolate each sub-level process from the influences of higher levels and from competing elements at the same level. A mechanism of limited extent, such as disease progress, is identified, and its behaviour explained in terms of relations of sub-level mechanisms such as latent and infectious periods and environment. These relations, limited in number, are quantified. Quantitative integration of those mechanisms into an explanatory model of system behaviour, however, remains a task for the crop protectionist who has to deal with the whole crop instead of the composing elements.

Mathematical models are used as a method to effect such integrations. This approach has been favoured by the absence of other effective methodologies, by the emerging formalism of systems analysis and by the availability of computers. Two broad categories of models may be distinguished: same-level descriptive models and multi-level explanatory models. A wide range of descriptive models exists. Multivariate regression models, for example, are used for yield loss assessment under variable conditions (Large, 1954; Teng *et al.*, 1980). Most of these models are static, i.e. they do not involve a concept of time. Variables are integrated seasonal totals of yield loss, disease intensity and/or abiotic factors such as temperature or rainfall. Sophistication is improved by introducing some concept of time based, for example, on the calculation of developmental rates of crop and disease as a function of temperature and by increasing the numbers and precision of environmental parameters such as humidity, wind speed, radiation. There are time-dependent models too. In epidemiology the logistic equation,

$$dx/dt = r \cdot x \cdot (1 - x)$$

is widely used as an example of a descriptive population model. In the foregoing chapters this equation has been applied as a first introduction to population dynamics in crop protection.

The explanatory approach, emphasised above, is considerably more sophisticated. It employs dynamic models of the system hierarchy in an effort to provide explanation and prediction of integrated behaviour from detailed descriptive knowledge at a lower hierarchical level (de Wit, 1968; Loomis *et al.*, 1979). These explanatory models interpret the epidemic on the basis of detailed knowledge of structural elements at the lower hierarchical level. In epidemiological models of diseases, latent period (p), infectious period (i) and corrected basic infection rate (R_c) are determined in laboratory studies under well-defined conditions. Explanatory models bridge the gap between these detailed studies and field performance of the disease. Correspondence between model calculations (simulation) and field observations, using the independent abiotic variables as forcing variables, increases our insight and helps in designing new experiments in order to test model performance and to quantify input/output relationships.

Thus, construction of the model and the study of its behaviour in comparison with the performance of the real system result in an explanation of the system's behaviour. This quantitative explanation is of a completely different nature from the teleological explanation often found in biology. The teleological approach, which explains behaviour from the viewpoint of its supposed function or purpose, can, however, have great heuristic value, and can stimulate the search for relations applicable in dynamic simulation.

B. The Modelling Process

Model building should begin with a clear formulation of objectives concerning the use of the completed model. Biological systems are so complex that their models always represent a simplification and abstraction of the real system. The objectives determine the limits of the system and the degree of simplification. The inter-connection of variables and processes defining the system is facilitated and visualised by the use of relational diagrams. These schematic representations of the model define the functional relationships which are quantified on the basis of information from the literature or appropriate experiments. Parametrisation is the word often used for this building step. Computer models or other algorithms are the next step in the modelling process. Verification, testing whether or not the computer program in fact operates on input data in the intended way, is a further step. Next, the model is validated by comparing model predictions with independent observation. Different validation procedures are used (Rabbinge and Carter, 1983) to evaluate model behaviour in comparison with the behaviour of the real

system. In most cases model behaviour and experimental results of field tests are compared visually, and this is normally sufficiently accurate. However, statistical tests using the χ^2 -test or other methods to test the correspondence between measured data and model calculations are also used.

A validated model can be used in sensitivity analysis to test the relative importance of different input relations and to pin-point gaps in our knowledge. Sensitivity analysis involves changing the values of rates, variables and initial conditions in the model to determine their contribution to the behaviour of the model. After sensitivity analysis, simplification is usually possible. Simplification leads to summary models which are used for decision making and other managerial purposes. The above description of the modelling process is idealised. In practice, many steps are iterative, that is to say, forward and backward steps are made continuously. In many cases a summary model forms the starting point of a comprehensive explanatory model.

C. Objectives of Modelling

Explanation is the main objective of simulation modelling. The design of explanatory models forces one to conceptualise all relevant relationships, even if they have not yet been studied experimentally. A misfit at testing time may suggest that one or more relations are missing. In such cases, simulation is an aid in gap finding. This heuristic effect is one of the secondary aims of simulation. Another secondary objective arises from the experience that many experimentally determined relationships give too much information. Often simulation results would have been nearly as accurate with, for example, half the amount of input information. If so, simulation can give guidance in efficiency of experimental work. The redundancy of information can apply to the number of measurements per item as well as to the number of items measured (e.g. temperature and relative humidity and dewpoint).

These objectives, one primary and two secondary, are meaningful only when simulation and experimentation go hand in hand and feed each other. This *conditio sine qua non* is, unfortunately, often overlooked. The experimentation has to be made at the explanatory level as well as the level to be explained, to feed (relationships and parameters), verify and validate the model.

Apart from the scientific uses of simulation characterised by the word 'understanding', the agricultural and technical applications must be considered, summarised in the word 'action'. Summary models and decision rules based on simulation studies may be developed to guide growers and help them make decisions on chemical treatments. (Not treating is a decision, too.) In doing so, the dynamic simulation model becomes part of a supervised control system. The authors' interest focuses on this type of application.

D. Examples of Epidemiological Models

Assume a classical rust development model based on the equations of Van der Plank (1963; Zadoks, 1971), considering the host as a constant. Disease severity is expressed as the quotient, x , of diseased leaf area over total leaf area. Reinfection is governed by an empirical value called the daily multiplication factor, R_c . In the flow diagram of the simulation model the material flowing through a sequence of states is leaf area. Imagine that the empirical R_c is now to be replaced by reinfection simulated by means of a spore dispersal model, based on environmental physics (Rijsdijk and Rappoldt, 1980). In a dispersal model, the material flowing through a set of states could be spores.

Introduction of a spore dispersal model into the population growth model may cause difficulties because different units are used in each, namely, leaf area and spores. The ‘coupling’ of the lesion flow and the spore flow models can be realized through two ‘couplers’, the spore liberation per unit area of leaf and the lesion size per spore deposited, both specified per unit time (time step) and per leaf layer. Leaf layer comes in because infection of old leaves is not relevant, whereas young leaves do not yet support sporulation. In Fig. 1, the coupling is indicated by dotted lines, which ‘translate’ one material into another, and the couplers are symbolised by squares, in which the coupling dimensions are entered. The two flows, thus coupled, form an information cycle within an epidemiological model. At every time step, the program goes through this entire cycle. When crop structure is introduced the situation

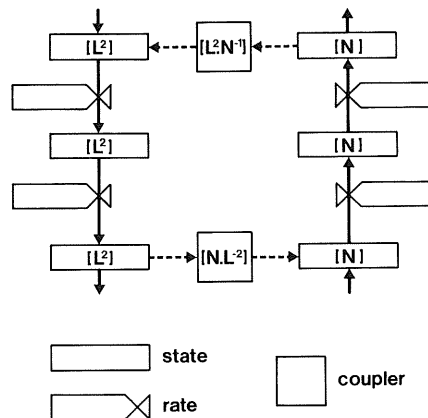

Fig. 1. Diagram of two coupled flows (heavy lines), one of area (e.g. leaf area, L^2) and one of numbers (e.g. spore numbers) coupled by two couplers, one translating leaf area into numbers (e.g. spores produced per cm^2) and one translating numbers into leaf area (e.g. lesion size in cm^2 per successful spore). In a similar way, two complex simulation models can be coupled, e.g. one of crop growth and one of spore dispersal.

becomes more complex. Leaf layers of different age differ in infectibility, latent period, infectious period and sporulation rate and this should then be introduced into the model (Rabbinge and Coster, 1984).

III. THE HOST CROP

A. Coupling of Models

To be realistic, epidemic models should consider the host as a variable (Zadoks and Schein, 1979). Growth and development of the host crop have to be simulated. Crop simulators exist in more (de Wit *et al.*, 1978) or less (Penning de Vries *et al.*, 1982) elaborate form, usually geared to the calculation of crop production under different conditions. In most epidemiological simulations, the crop is considered to operate at the optimum level, i.e. conditions are such that neither water nor other factors limit crop growth. This implicit assumption is in many cases invalid. de Wit (1982) distinguishes four levels of crop production, as follows.

Production level 1. Growth occurs in conditions with ample plant nutrients and soil water all the time. The growth rate is determined by the physiological characteristics of the crop and weather conditions.

Production level 2. Growth is limited by water at least part of the time, but when sufficient water is available the growth rate increases up to the maximum rate set by the weather.

Production level 3. Growth is limited by shortage of nitrogen at least part of the time and by water or weather conditions for the remainder of the growth period.

Production level 4. Growth is limited by the low availability of phosphorus, or by that of other minerals like potassium at least part of the time, and by nitrogen, water or weather for the remainder of the growth period.

For different production levels, different yields are expected and crop conditions are quite different. This affects the relation between host crop and disease. At each production level, pests and diseases do occur but the species may vary. The epidemiological characteristics and the damage relations of several pests and diseases are affected by crop condition (Cowan and van der Wal, 1975; Ayres and Zadoks, 1979). Thus diseases and pests of poor and rich crops exist (Zadoks, 1974; Rabbinge *et al.*, 1983).

B. Epidemiological Aspects

To simulate the epidemic of a foliar pathogen, specific data are needed such as leaf layers with their position along the stem, size, such as Leaf Layer Area

Index (LLAI), day of appearance and disappearance of leaves, inclination (angle), maturation (in relative age or in degree · days), and so on. All these items may affect infectibility expressed as lesions realised per germinated spore and sporulation capacity expressed as spores produced per lesion or per unit area. Specific information on leaves as required here is usually not explicitly provided by crop production models, but it can often be derived from them with moderate effort (van Keulen and Seligman, 1985). Once available, the crop model and the epidemiological model can be coupled.

Unfortunately, coupling of a comprehensive crop model to an epidemiological model is often a nuisance, because the two model types operate at different hierarchical levels with very different time steps. Such coupling is technically very difficult and usually it is not necessary to go to such pains. In many cases it is more profitable to proceed in steps. The comprehensive crop model is first reduced to a summary model. The summary crop model is used as a part of a combination model to calculate only those leaf data needed in the epidemics section of the combination model. As time steps of integration for simulation of crop data and for simulation of the epidemic may be different, combination models have to deal with so-called stiff equations (Goudriaan, 1973, 1977). To circumvent these problems different methods have been developed. The main program is run with relatively large time steps, whereas the sub-model describing the process with the small time coefficient is executed several times during each time step.

Combination models of crop growth and crop diseases are already producing realistic results and pave the way for the development of epidemiological summary models for use in crop management (Rijsdijk, 1982; Rabbinge and Rijsdijk, 1983). The stepwise approach described above results in useful summary models and reduces computer time and programming difficulties.

C. Injury–Damage Relationships

A further and more refined scientific aim is simulation of the effect of a disease on crop production. Seldom is there a straightforward relation between injury, assessed by eye, and damage, measured as reduction of marketable produce. If so, a feedback of pathogen on host by calculating destroyed leaf area is no longer sufficient. The pathogen affects the host in various ways, poisoning host leaves, promoting senescence or stimulating respiration. The pathogen may change the source–sink relations within plants and therewith influence the flow of assimilates, also into those sinks which later may become sources (Gaunt *et al.*, 1983). Thus, a feed-forward process comes into being.

Another problem is that lesions, even when growing under identical conditions, need not have equal effects (Zadoks and Schein, 1979). Complications arise when different production levels are considered. Cereal aphids on wheat, for example, cause much more yield loss per unit of aphid pressure at a high yield level than at a low yield level. The reason for this difference lies with the causes of yield loss (Rabbinge and Coster, 1984). Apparently, new objectives must be formulated to pursue our refined modelling: (1) the physiological effects of disease in response to production level need to be studied in detail, and (2) the coupling between host and pathogen models needs to be made at the elementary, physiological level. Such studies are in an incipient stage only.

D. Simulating the Farmer's Situation

Models as indicated above do not adequately represent the farmer's situation, because the farmer, at least in northwest Europe, always faces more than one harmful agent (Zadoks and Schein, 1979). It seems possible to use one summary crop model as a basis for several pest and disease models, at least when these are considered one by one, but this has rarely been done. The exception is probably cotton. Detailed models of the crop are combined with commensurately detailed models of insect pests (Gutierrez *et al.*, 1976; Peacock, 1980).

In the farmer's situation, however, diseases and pests do not develop independently. They influence each other in various ways; examples for wheat are

<i>Puccinia recondita</i> and <i>Septoria nodorum</i>	(van der Wal <i>et al.</i> , 1970; van der Wal and Cowan, 1974)
<i>Pseudocercospora herpotrichoides</i> and <i>Puccinia striiformis</i>	(van der Wal and Zadoks, 1971)
<i>Erysiphe graminis</i> and <i>Griphosphaeria nivalis</i>	(Forrer <i>et al.</i> , 1982)
<i>Lema melanopa</i> and <i>G. nivalis</i>	(Forrer <i>et al.</i> , 1982)

The mutual influences cannot usually be coupled by way of leaf area infected, as they refer not only to the plant parts immediately affected but also to plant parts indirectly affected by way of a translocatable agent (*P. recondita* and *S. nodorum*) or of a nutritional feed-forward. For good modelling, the intrinsic route has to be followed at the physiological level.

Such multiagent-host models as suggested here do not yet exist. They may be constructed in the future. The constraint is not computer hardware or software, but the basic knowledge on input relations. To get this information, much detailed and painstaking research is needed. Most of this research is yet to be done. A possible application of the multiagent model will be discussed in the following section.

IV. PRACTICAL APPLICATIONS OF SIMULATION MODELS

A. 'Managerial Models'

It is not so easy to apply simulation models in practice: the most obvious use is in prediction, strategic or tactical (Shoemaker, 1981). Strategic models refer to long-term approaches, often have a general validity and indicate the consequences of certain pest and disease control policies. The choice of variety, production level, regional characteristics, etc., may come into a strategic model. Tactical models refer to the short run and the individual field. They react to the stimuli of the moment and need to be applied frequently during the growing season. The pest and disease manager, in many cases the farmer, wants to make a decision on whether to treat or not and he likes to decide on the basis of calculated alternatives. Strategic models offer him different policies and the consequences thereof. Tactical models are tailored to a specific option and the ensuing specific needs of their users. Unfortunately very few, if any, simulation models are 'managerial models' that predict not only the effect of fungicide applications on damage but also the financial results of managerial actions. The study of the epidemiological mode of action of fungicides has been neglected, even though it has been demonstrated that the results can be used in simulation models (Zadoks, 1982). The economics of fungicide applications have rarely been simulated, if at all.

The question which now arises is not whether it is possible to make such elaborate simulators but whether it is sensible to do so. The argument against elaborate managerial models is threefold: (1) They will be large and therefore expensive to run as an on-line per-field service, (2) they will provide a superfluous precision for some aspects which cannot be validated, and (3) they will lead to a reduced attention for other effects sometimes more important than pests or pathogens, such as considerations of profitability. Models for managerial use should contain a bare minimum of detail, with as few variables as possible. The first argument could be overcome by the construction of a 'summary model'. The second and third arguments are more fundamental. The problem is to prove that additional state variables are necessary and do not reduce attention from other important aspects. This proof can only be provided by an iterative working method combining theoretical and experimental work. The accuracy of field trials in crop protection is, however, rarely better than 5% difference in yield. If this error is expressed in terms of money its value often exceeds the added value of one treatment.

An example will clarify the point. Around 1980, Dutch wheat yields were on average about 7 metric tonnes per hectare. The accuracy of field trials is at

best some 5%, or about 350 kg ha⁻¹. The costs of a treatment are also about 350 kg ha⁻¹. (By the way, 350 kg ha⁻¹ is less than 2 days' dry matter production.) As the accuracy of a field trial money-wise is in the order of one treatment, the simulation can be verified up to an accuracy of $\pm\frac{1}{2}$ treatment at best. When gross yield is used to check the accuracy of the simulation, as is the normal case, the attainable accuracy lies within the limits corresponding with a money value of ± 1 treatment.

Greater precision in testing the accuracy of the simulation can be obtained by using other field data assessed during the growing season. The choice of the data depends on the objective of the study. For managerial purposes, the 'treatment', whatever its nature, is the entity to decide upon. Its added value is here considered as a 'unit of currency'. In management, precision better than $\pm\frac{1}{2}$ treatment is a waste of effort.

B. Decision Making

For managerial purposes superfluous precision is a nuisance rather than an advantage. This and other reasons may lead to simplification, from comprehensive model over summary model to decision models. The latter can take the form of decision trees or networks with a limited number of yes-no alternatives, ending in at most three options: treat, do not treat, or wait and see. The large number of time steps in the comprehensive model is reduced to the relatively few moments that a manager can profitably decide to do something or not to do it. The original simulation model should help to develop these decision criteria.

Decision models can be arrived at along other paths than simulation. An example of a decision model in disease forecasting, based on the recognition of critical periods, is the elaborate, computerized, field-specific BLITECAST against *Phytophthora infestans* on potatoes (Krause *et al.*, 1975). PHYTPROG, also computerized but not field specific, uses a form of field monitoring (Burckhardt and Freitag, 1969). Both examples contain decision criteria but they are not simulators. Spray recommendations using simulators seem feasible only when the simulator of disease is initialised for the specific conditions of the field for which the recommendation is wanted.

A decision model such as EPIPPE (Rabbinge and Rijdsdijk, 1983; Rijdsdijk, 1982; Zadoks, 1981, 1983), originating in part from elaborate simulation models, still reflects its simulation origin. Simplification was obtained by checking only whether or not a damage threshold would be surpassed, instead of calculating the whole course of the epidemic. In one version, it had some 25 decision points. In a newer version, further simplification is obtained by calculating the added values for a number of options and selecting the highest one.

C. Optimisation

Decision systems such as BLITECAST and EIPRE attempt to optimise disease control but they do not yet utilise mathematical optimisation techniques. During the last decade optimisation techniques have been introduced into crop protection at several places (Shoemaker, 1981). Text-books indicate how and where to use these techniques (Jeffers, 1978).

Classic optimisation theory tended to study problems of industry with few but large enterprises. In agriculture, the theory should adjust to a large number of small enterprises, with different perceptions of risk. Only recently, stochastic elements have been introduced in these models in order to compute chances for optimal solutions. Given a certain combination of constraints and a set of environmental factors, and given the variation in these environmental factors, the model turns out optimal solutions with their chance densities. Stochasticity enables the user to decide upon the degree of risk (in money) he is prepared to accept within a chosen control strategy and to see the costs involved. In optimisation, decisions can be made for the whole growing season at once, or stepwise by deciding for each optimisation period. In both cases the consequences of a certain decision have to be calculated. Dynamic simulation models can be used for part of the necessary computations (Onstad *et al.*, 1983). Simulation and optimisation are complementary tools in pest and disease management!

V. LONG-TERM PERSPECTIVES

A. Crop Management Models

Farmers are not interested in one-disease-only recommendations. Pest and disease control is just one of the many crop husbandry actions to take. Many farmers consider this part of crop management as relatively unimportant, even though crop protection involves about 15% of their time and expenditure (Zadoks, 1980). They have to deal with a crop situation in which several choices have to be made. The varieties they choose, the crop husbandry practices they apply and the weather they experience affect crop growth and diseases and pests differentially. In addition, modern pesticides have plural effects; for example, triadimefon gives good protection of wheat against *P. striiformis* and *E. graminis* and fair protection against *P. recondita* and *S. tritici*. Others, such as sulphur, protect apple leaves against mildew (*Podosphaera leucotricha*) but kill beneficial predatory mites, and so on. 'Multi-agent + crop' managerial models in whatever form are a necessity indeed for farmers' acceptability and thus for further progress. Such models should become available in the mid-1980s.

Several other crop management decisions affect harmful agents, such as weed control, fertilizer applications and irrigation. EPIPARE was designed to recommend omission of the last N top dressing of wheat when *P. striiformis* had already attained a certain critical severity. The future will see comprehensive crop management models of which the crop protection aspects will be just one portion. In the Netherlands, work is in progress on aspects of timing and amount of nitrogen fertilisers and herbicides for wheat. Gradually, a complete crop management system will be developed. The main objective of this management system is maximisation of financial returns, but as societal aims change, pesticide minimisation may become another objective affecting management policies. EPIPARE already contains environmental thresholds in rudimentary form (Zadoks, 1983). Irrigation has already been incorporated for cotton, including a link with crop protection (Gutierrez *et al.*, 1976). Other economic or convenience options, such as an early and short picking period versus a more regular and prolonged picking period, are in operation now (Peacock, 1980), and these options have their specific crop protection implications. Before 1990, we will probably see supervised crop management systems in cotton and wheat, and possibly in a few other crops too, with higher farmer acceptability. Here, acceptability means three things: (1) the farmer is able to understand the background and the reason for the recommendation; (2) he is willing to accept a calculated risk; and (3) he is willing to pay a fee for a recommendation which may save him money. When the objectives of farmers or of society at large change, new optimal policies can be determined by running the dynamic optimisation program once more.

B. Centralised and Decentralised Systems

At the time of writing, 1983, most computerised management systems are centralised systems. This means that a central computer, far away from the target field, does the necessary calculations. Communication between farmer and computer is by mail (EPIPARE), by phone (BLITECAST) or by visiting consultant carrying a microcomputer that can interact with the main-frame computer (APPLESCAB). Faster interaction can be organised through VIDITEL systems, connecting home television screen and central computer by the public telephone network; such systems also permit two-way interaction between farmer and central computer.

Decentralised systems with on-the-farm and in-the-field devices will be implemented before 1990. Precursors are the various gadgets helping the grower to decide whether or not to treat against *Venturia inaequalis*. More sophisticated are the small \$1000 black boxes called BLITECASTER, placed in the potato crop (MacKenzie and Schimmelpfenning, 1978). They monitor the microclimate of the crop and they inform the farmer according to the

BLITECAST program when sprayings are needed, thus obviating the necessity to communicate with the central computer. The next step is the installation of on-the-farm microcomputers which run not only farm administration programs, but also crop protection or even total crop management programs. Of course, these microcomputers can be connected with sensors placed in the field. Thus, the farmer will expand his diagnostic equipment and feel more independent. He will have his answers faster than by way of the central computer. For EPIPRE, a microcomputer adaptation for on-the-farm use has been developed. One disadvantage of decentralisation is the absence of communication between the farmer and the research organisation which is responsible for the recommendations and advisory system. A more serious disadvantage lies in the difficulty of updating a program rapidly in response to changes in the pathogen such as the appearance of a new race or a fungicide-resistant strain. A combination of centralisation and decentralisation seems feasible and might reduce the disadvantages of both.

VI. INTEGRATIONISTIC SCIENCE

The developments described in this chapter will stimulate a great deal of holistic research, that is research placing small elements of knowledge in their proper perspective or as 'proportional' parts of complex but operational bodies of knowledge. Maybe such research will help somewhat to reduce the redundancy of present scientific information, and at the same time help to identify and fill gaps in our knowledge. Such research will also help to bridge the present gap between 'understanding' and 'action'. If so, the lost feeling of 'scientific proportion', as John Grainger (1979) put it so nicely, will be restored. The integrationistic approach, as contrasting to much of the current reductionistic research activities, is one of the great contributions of dynamic simulation to modern science.

REFERENCES

- Ayres, P. G. and Zadoks, J. C. (1979). *Physiol. Plant Pathol.* **14**, 347-361.
Burckhardt, H. and Freitag, E. (1969). *Der Kartoffelbau* **20**, 176-180.
Cowan, M. C. and van der Wal, A. F. (1975). *Neth. J. Plant Pathol.* **81**, 49-57.
de Wit, C. T. (1968). *Landbouwk. Tijdschr.* **80**, 215-218.
de Wit, C. T. (1982). In 'La Productivité des Pâturages Sahéliens'. pp. 20-35. (F. W. T. Penning de Vries, and M. A. Djitéye eds.), Pudoc, Wageningen.
de Wit, C. T. and Goudriaan, J. (1978). 'Simulation of Ecological Processes'. *Simul. Monogr.* Pudoc, Wageningen.

- de Wit, C. T., Goudriaan, J., van Keulen, H., van Laar, H. H., Louwerse, W., Penning de Vries, F. W. T., Rabbinge, R. and Sibma, L. (1978). 'Simulation of Assimilation, Respiration and Transpiration of Crops'. *Simul. Monogr.* Pudoc, Wageningen.
- Forrer, H. R., Rijsdijk, F. H. and Zadoks, J. C. (1982). *Neth. J. Plant Pathol.* **88**, 123-125.
- Gaunt, R. E., Lim, L. G. and Thompson, W. J. (1983). *FAO Plant prot. Bull.* **30**, 3-8.
- Goudriaan, J. (1973). *Neth. J. Agric. Sci.* **21**, 269-281.
- Goudriaan, J. (1977). 'Crop Micrometeorology: a Simulation Study'. *Simul. Monogr.* Pudoc, Wageningen.
- Grainger, J. (1979). *Annu. Rev. Phytopathol.* **17**, 223-252.
- Gutierrez, A. P., Falcon, L. A. and van den Bosch, R. (1976). In 'modelling for Pest Management, Concepts, Techniques and Application' (K. Tummala, D. L. Haynes, and B. A. Croft, eds), pp. 134-145. Michigan State Univ. Press, East Lansing.
- Jeffers, J. N. R. (1978). 'An Introduction to Systems Analysis with Ecological Applications'. Arnold, London.
- Jeger, M. J. and Rabbinge, R. (eds.) (1983). *Bull. IOBC/WPRS NS 1983/VI/2*.
- Kranz, J. and Hau, B. (1980). *Annu. Rev. Phytopathol.* **18**, 67-83.
- Krause, R. A., Massie, L. B. and Hyre, R. A. (1975). *Plant Dis. Rep.* **59**, 95-98.
- Large, E. C. (1954). *Plant Pathol.* **3**, 128-129.
- Loomis, R. S., Rabbinge, R. and Ng, E. (1979). *Annu. Rev. Plant Physiol.* **30**, 339-367.
- MacKenzie, D. R. and Schimmelpfenning, H. G. (1978). *Am. Potato J.* **55**, 384-385 (abstr.).
- Onstad, D. W., Rabbinge, R. and Rossing, W. (1983). *Proc. Br. Crop Prot. Symp. 1983 I*, 191.
- Peacock, W. J. (1980). *Agric. Gaz. N.S.W.* **91**, No. 4.
- Penning de Vries, F. W. T. and van Laar, H. H. (eds.) (1982). 'Simulation of Plant Growth and Crop Production'. *Simul. Monogr.* Pudoc, Wageningen.
- Rabbinge, R. and Carter, N. (1983). *Bull. IOBC/WPRS NS 1983/VI/2*, 18-30.
- Rabbinge, R. and Coster, G. (1984). *Proc. Aust. Appl. Entom. Res., 4th*, 163-169.
- Rabbinge, R. and Rijsdijk, F. H. (1983). *Bull. OEPP*. **13**, 297-305.
- Rabbinge, R., Sinke, J. and Mantel, W. P. (1983). *Meded. Fac. Landbouwwet. Rijksuniv. Gent* **48/4**, 1159-1168.
- Rijsdijk, F. H. (1982). *Proc. Br. Crop. Prot. Symp. 1982*, pp. 65-76.
- Rijsdijk, F. H. and Rappoldt, K. (1980). *Ber. Umweltbundesamt* **5/79**, 407-410.
- Ruesink, W. G. (1976). *Annu. Rev. Entomol.* **21**, 27-44.
- Shoemaker, C. A. (1981). *IEEE Trans. Autom. Control* **26**, 1125-1132.
- Teng, P. S., Blackie, M. J. and Close, R. C. (1980). *Agric. Syst.* **5**, 85-103.
- van der Plank, J. E. (1963). 'Plant Diseases: Epidemics and Control'. Academic Press, New York.
- van der Wal, A. F. and Cowan, M. C. (1974). *Neth. J. Plant Pathol.* **80**, 192-214.
- van der Wal, A. F. and Zadoks, J. C. (1971). *Proc. Int. Symp. Plant. Pathol., 2nd*.
- van der Wal, A. F., Shearer, B. L. and Zadoks, J. C. (1970). *Neth. J. Plant Pathol.* **76**, 261-263.
- von Keulen, H. and Seligman, N. G. (1985). In press.
- Zadoks, J. C. (1971). *Phytopathology* **61**, 600-610.
- Zadoks, J. C. (1974). *Phytopathology* **64**, 918-923.
- Zadoks, J. C. (1980). *Landbouwk. Tijdschr.* **92**, 313-323.
- Zadoks, J. C. (1981). *Bull. OEPP* **11**, 365-369.
- Zadoks, J. C. (1982). In 'Fungicide Resistance in Crop Protection' (J. Dekker and S. G. Georgopoulos, eds.) pp. 149-160. Pudoc, Wageningen.
- Zadoks, J. C. (1983). *Ciba Found. Symp.* **97**, 116-125.
- Zadoks, J. C. and Schein, R. D. (1979). 'Epidemiology and Plant Disease Management'. Oxford Univ. Press, New York.