

INVESTOR BEHAVIOR IN DETERMINING INVESTMENT ON REAL ASSET

Yuniningsih and Muhamad Taufiq

*Faculty of Economics and Business Universitas Pembangunan Nasional "Veteran" East Java,
Surabaya, Indonesia*

yuniningsih@upnjatim.ac.id, taufiqtb4@gmail.com

Abstract. Behavior in determining investment is influenced by factors from the fundamental side or individual psychology. This study aims to determine how psychological factors influence investor behavior in determining future investments. This research is a field experimental study using questionnaire data. The variables used in investment decision making include loss aversion, regret aversion and illusion of control bias with 15 total indicators. The sample is an investor in the real asset field and the data is processed using the Structural Equation Model (SEM) with the AMOS program. The results showed that psychological factors both loss aversion and illusion of control bias had a significant effect on investment decisions in a positive direction. While regret aversion has a significant effect with negative direction with investment decisions. Novelty in this study, that psychological factors in behavior finance not only affect securities investors but also real asset investors.

Keywords: Behavior Finance, Loss Aversion, Regret Aversion, Illusion Of Control Bias, Investment Decision

Abstrak. Perilaku penentuan investasi dipengaruhi oleh banyak faktor baik dari sisi fundamental maupun psikologi individu. Penelitian ini bertujuan untuk mengetahui bagaimana faktor psikologi mempengaruhi perilaku investor dalam menentukan investasi yang akan dilakukan. Penelitian ini merupakan penelitian eksperimental lapangan dengan menggunakan data kuisioner. Variabel yang digunakan dalam penentuan keputusan investasi meliputi loss aversion, regret aversion dan illusion of control bias dan ada 15 jumlah total indikator yang digunakan dalam penelitian ini. Sampel menggunakan investor di bidang real asset dan data diolah menggunakan Structural equation Model (SEM) dengan program AMOS. Hasil penelitian menunjukkan bahwa faktor psikologi baik loss aversion dan illusion of control bias berpengaruh signifikan dengan keputusan investasi dengan arah positif. Sedangkan regret aversion berpengaruh signifikan dengan arah negative dengan keputusan investasi tetapi. Novelty dalam penelitian ini bahwa faktor psikologi dalam behavior finance tidak hanya mempengaruhi investor sekuritas saja tetapi juga investor real asset.

Kata kunci : Behavior Finance, Loss Aversion, Regret Aversion, Illusion Of Control Bias, Keputusan Investasi

INTRODUCTION

Investment decisions relate to determining the source and allocation of funds. Sources of funds can come from external finance, internal equity and external equity (Y Yuniningsih, Pertiwi, & Purwanto, 2019) (Yuniningsih Yuniningsih, Taufiq, Wuryani, & Hidayat, 2019). Funds that have been obtained can be invested in real assets or financial assets. The purpose of investors investing is basically to get a return. Return can be measured by the amount of financial reward or capital gain received. Likewise, All Investor in State Wealth and Auction Service Office (KPKNL) Sidoarjo, east java, Indonesia. KPKNL is the executor of activities and service institutions in the state-owned auction. Most of the auction at KPKNL Sidoarjo, Indonesia in the form of real assets in the form of

vehicles, houses, land, factories, warehouses and others. Most auction users or investors in KPKNL Sidoarjo are investors who have experience in conducting auctions. The aim of investors is to conduct a real asset auction to get a profit. Profits are obtained because the price of assets offered and approved by the appraisal, tends to be lower than the market price. Most investors assets from auction will be resold for higher price. Investors auctioned at KPKNL Sidoarjo, Indonesia is also inseparable from many factors that influence investment decisions.

The influential factors in the investment decisions of investors can come from both external and internal. External factors can be economic, political, natural conditions, asset prices, policies and others. While the internal side comes from the individual itself, especially from the psychological, knowledge, education and others. This research is focused on behavioral finance which involves between fundamental and psychological factors. Psychological factors play an important role in influencing conditions of indifference in making investment decisions. Behavior finance is the development of the theory of traditional finance or fundamental theory. One theory of traditional finance is the EMH theory (efficient market theory) introduced by (Malkiel & Fama, 1970). As mentioned by (Shiller, 2003) EMH theory emphasizes that everyone always acts rationally. Act rationally because investors get very good information about the price of financial asset good assets in the form of securities or real assets. Fundamental financial theory is based on the assumption that all investors or people tend to be in certainty. This definite and rational condition in fundamental financial theory is not able to explain how investors behave in the real market. (Pertiwi, Yuniningsih, & Anwar, 2019), (Y Yuniningsih et al., 2019), (Yuniningsih Yuniningsih et al., 2019) stated that in making decisions is influenced by many factors both fundamental and psychological.

Behavioral finance as a new discipline in finance that tries to understand and better explain the behavior of investors from the psychological side in the process of making investment decisions. Some opinions about behavioral finance include (Lintner, 1998), (Pompian, 2011). (Lintner, 1998) behavioral finance is the study of how humans interpret and act on existing information to make an investment decision. (Pompian, 2011) mentions behavioral finance as an application of psychology in financial disciplines. The conclusions of the three opinions above show that to make financial decisions, especially investment, besides being influenced by fundamental factors, it is also influenced by various psychological biases that an individual has from each investor.

Some behavioral finance researchers, for example (Pavabutr, 2002), (Hoffman, 1972) (Mittal, 2010) and others believe that investors, especially individual investors, do not always act rationally but sometimes act irrationally in making investment decisions. As (Pavabutr, 2002) said that investors have a tendency to behave biased which leads to making systematic mistakes in investment decisions. (Hoffman, 1972) also states that informal investors in investment decision making are based on central factors such as individual preferences, past investment experiences and individual biases. Investors' investment decisions are often controlled by emotions, prejudices, desires, goals, high self-confidence and so on that encourage irrational action. Psychological influences can influence investment decision making (Mittal, 2010). (Mittal, 2010) also states that the most frequently influencing and changing individual investment decisions are overconfidence, framing effects, reference dependence, loss aversion, overreaction and underreaction and others. In this study the factors that influence investment decisions are emotion bias, and cognitive bias.

Emotion bias in this study is seen from loss aversion and regret aversion. A person's emotion bias can be seen from the positive and negative side. Both of these emotional conditions can influence investor behavior in making investment decisions. Loss aversion is considered a deep sense of remorse if an investor experiences a loss, rather than the pleasure gained if he gains even though in the same nominal amount (D Kahneman & Tversky, 1979). Regret aversion is said to be a feeling of fear of acting, trying to avoid mistakes in making the same decision (Pompian, 2011). Meanwhile, in terms of cognitive bias in this study, it discusses illusion bias of control. Illusion of control bias is

a behavior that believes in the ability to control but in reality is unable to control or influence the final outcome (Pompian, 2011). Investors, both securities and real asset investors, will be influenced by the psychology of both emotions and cognitive biases. KPKNL investors, who are investors in real assets, whose behavior in decision making is inseparable from (D Kahneman & Tversky, 1979) the influence of this psychology. This study aims to analyze how much psychological factors both from loss aversion, aversion regression and illusion of control can affect KPKNL investors. Based on the explanation of the three variables previously, KPKNL Investors are inseparable from psychological influences

LITERATURE REVIEW

Investment Decision. Investment decisions are decisions made by anyone individually, in groups, institute and others. Investors in making investments are faced with many choices in real assets and financial assets to get profits. Many factors must be considered in determining investment both, in terms of knowledge or experience, in the form of internal and external factors. External factors can be based on economic and political developments. While internal factors originate from within a person, especially psychology, experience, knowledge and so on. The psychological side can be seen from the side of behavioral motivation both from the framing effect, emotion bias, demography, cognitive bias and so on. Bias psychology in behavioral finance on investment decision making tends to shift human actions from rational actions to irrational actions. As stated by (D Kahneman & Tversky, 1979) in conditions of uncertainty, humans in making decisions will shift from decisions that can be predicted by fundamental economic theory. As (Landstrom, 1995) research shows that individual investors seem to avoid information uncertainty based on assumptions that are difficult to evaluate. The uncertainty of information is caused by lack of information about the company or assets and psychological factors of investors. This uncertainty factor affects the courage of investors in deciding on investments whether investors have behavior with risk taking or risk averse.

Loss Aversion. Emotion according to (Ackert, Church, & Deaves, 2003) is an important aspect of each individual that can influence decision making towards better or worse. Emotion bias in this study was reviewed from two factors, namely loss aversion and regret aversion. Loss aversion in the prospect theory of (Daniel Kahneman, 1979) define as a person's actions to hold stocks for longer periods of loss but will quickly sell shares that have experienced gains. (Daniel Kahneman, 1979); (Daniel Kahneman, Knetsch, & Thaler, 1990). The statement is supported by (Levy, 1992) that loss aversion is the tendency of people to judge at least the pleasure newly acquired compared to the amount of regret when losing or getting a loss. The explanation of (Levy, 1992) is made clear by the description by (Thaler, Tversky, Kahneman, & Schwartz, 1997) that is, if someone losses \$100 will be very sorry compared to the pleasure they get when they gain \$100. (Haigh & List, 2005) also stated that people with loss aversion will focus more on higher levels of caution when loss, compared to gain. This illustrates how people will be more sorry if faced with a loss compared to pleasure when getting a gain even in the same nominal amount.

Opinions from the researchers mentioned above means that psychologically investors either individually or in groups are faced with two facts, namely generating income and experiencing losses. When receiving a profit it is sometimes considered a common thing. on the contrary when loss even with smaller or equal amount when getting profit results in deep regret. This condition of loss aversion will influence decision making whether investors are risk takers or risk aversors. When receiving a profit it is sometimes considered a common thing. on the contrary when loss even with smaller or equal amount when getting profit results in deep regret. This condition of loss aversion will influence decision making whether investors are risk takers or risk aversors. Loss aversion

investors will be more careful about making investment decisions and will increasingly avoid risk because they do not want to suffer losses or vice versa. This explanation is in accordance with the prospect theory of (D Kahneman & Tversky, 1979), someone whose loss aversion will determine the size of the risk taking investment made.

Regret Aversion. Another review of emotions in this study was Regret aversion. Regret aversion shows the feeling of fear in taking action by avoiding mistakes in the same decision explicitly (Pompian, 2011). Someone who anticipates regrets by using a decisions deay strategies (Zeelenberg & Pieters, 2007), escalation of commitment (Wong & Kwong, 2007). (Anderson, 2003) the type of decision delay is divided into 4, namely status quo bias, Ommision Bias, Choice deferral, Inaction inercitia. Status quo bias explains an act of someone who tends not to change decisions. Ommision Bias explains how someone who tends not to take action (Ritov & Baron, 1990). Choice deferral explain how investors behave to delay decisions so they can get more information in supporting decisions. Inaction inercitia which explains someone tends to miss the next opportunity because they did not take the opportunity before (Tykocinski, Israel, & Pittman, 2004). In Conclusion Regret aversion makes investors worry about price changes in both real assets and financial assets that cause losses. When investors experience losses, investor will emotionally desire not to do and not continue the investment. Regret aversion can occur when the investor experiences a loss or gains. As explained by (Pompian, 2011), regret aversion bias causing investors to be too conservative about the market which has been continuously decreasing market prices. Market conditions that continue to fall will cause losses to investors if they will sell shares. According to (Pompian, 2011), investors will sell shares if the value of the shares shows good value and the company is in good company condition. A sense of worry about changes in the company's stock price is not only when the stock price drops but also when there is a change in stock prices rise. The two opposite conditions will give a signal of investor behavior in making investment decisions that will be made. When the stock price drops, investors tend to buy shares. Conversely, when stock prices rise investors tend to sell shares. Both investor behavior and actions are basically aimed at making a profit. The act of buying when the price goes down and sells when the rising price of the asset owned also applies to KPKNL investors. KPKNL investors will make purchases when the price of assets in the cheap market and will be sold when the asset price increases. The difference between the purchase price and the selling price of the asset, the investor will benefit.

Illusion Of Control Bias. Another factor in this study was cognitive bias factors. Cognitive bias is related to one's acceptance, reasoning, understanding and thinking in making decisions, especially investment decisions. The factor in cognitive bias in this study is Illusion of control bias. Illusion of control bias according to (Pompian, 2011) is a human tendency that believes that they have the ability to control and influence results but in reality cannot control it.

Things that can be considered and at the same time encourage investors to make investment choices are investment choices, order of investment results, investment infra-structure, past success, information, and active involvement (Nofsinger, 2011). In addition, investors who have a successful investment in the past will also determine the courage of investors to make investment decisions. Illusion of control means that there is confidence in the ability to make the right investment decisions because of the right knowledge and information, but in reality cannot make the right decisions. The better the choice of investment priorities, knowledge, information and activeness, the more careful investors are in making decisions. Or the lower the illusion of control bias, the more careful in making investment decisions. Conversely, an investor who lacks priority in investment choices, knowledge, information and is less actively involved tends to be more confident and more

courageous in making investment decisions. If it is concluded, the higher the illusion of control bias, the bolder the investment decision.

Based on the previous explanation, KPKNL Investors are inseparable from the influence of psychological factors in making investment decisions, especially in terms of loss aversion, regression aversion and illusion of control. Besides psychological factors, fundamental factors also influence the making of investment decisions. The merger between these two factors shows that KPKNL investors are inseparable from behavioral finance in auction activities. Based on exolanation above, the hypothesis proposed in this study:

- H1. Loss aversion has a negative effect on investment decisions
- H2. Regret Aversion has a negative effect on investment decisions
- H2. Bias Illusion of Control has a positive effect on investment decisions

METHOD

Types of research. This type of research is an experiment with a field study because it uses primary data with the survey method. The survey method, uses the basic questionnaire, addressed to auction investors as participants.

Population and sample. The research population was investors at the State Wealth and Auction Service Office (KPKNL) Sidoarjo, East Java, Indonesia.

This study uses 4 latent variables and 15 indicators. Sampling is based on Hair et al., (2006:742) 5-10 times the total indicator, which is around 75 -150 respondents. Sample data taken in this study amounted to 100 participants and fulfilled the specified conditions, mentioned by hair et al (2006:742). Sampling was done by non-random sample technique and purposive sampling, using criteria that participants had conducted an auction of at least 1X. In this study participants were grouped 1-2X who had participated in the auction totaling 68 investors and more than 2X participated in the auction totaling 32 investors. The statistical test tool used in this study uses Structural Equation Modeling (SEM) with the AMOS program.

Operational definitions and variable measurements.

Investation decision (Y). Decision related to investor behavior in making investment decisions in the form of real assets. There are 6 (six) indicators in measuring investment decisions. 5 (five) indicators that refer to (Subash, 2012) include having knowledge about auctions, having knowledge of financial management, having knowledge of investing money, having knowledge of price fluctuations, having knowledge in making money budgets and 1 (one) indicator referring to (Wulandari & Iramani, 2014) which is investing based on feelings.

Loss aversion (X1). The investor's tendency to regret so much when he loses, rather than pleasure when receiving profits even with the same amount. Loss aversion in this study uses 3 (three) indicators. 2 (two) indicators refer to (Pompian, 2011) which is always avoiding losses and always investing in the same assets. 1 (one) other indicator from Phuachan (2010) in (Yuniningsih Yuniningsih, Widodo, & Wajdi, 2017) that is deciding to buy when the price drops.

Regret Aversion (X2). The fear of investors in taking decisive action by avoiding mistakes in the same decision (Pompian, 2011). The Regret aversion indicator uses 2 (two) indicators that refer to (Pompian, 2011), namely fear of asset losses and avoiding the same losses that have been made.

Illusion of control bias (X3). Investors who are very confident because they consider themselves to have a high ability to control and influence results, but reality does not have the ability to make the right decisions. There are 4 (four) indicators measuring Illusion of control. 3 (three) indicators refer to (Nofsinger, 2011) which includes past success, familiarity, active involvement. And one (1) indicator from (Pompian, 2011), which is about confidence, can overcome all problems caused.

Each indicator from investment decisions, loss aversion, regret aversion and illusion of control can be measured using a Likert scale by giving 5 (five) answers, namely from points 1 to 5. Point 1 gives a strongly disagree answer, point 2 disagree, point 3 is neutral, point 4 agrees and point 5 strongly agrees.

RESULTS AND DISCUSSION

Results. Before testing the hypothesis, it is necessary to test the level of accuracy and internal consistency, suitability of the model and data distribution. The type of test is the test of validity and reliability, measurement model, normality evaluation. After all the tests have been carried out, a structural evaluation of the model is performed both covariance and hypothesis testing.

Evaluation of validity and reliability. The validity test technique in this study uses the person product moment correlation technique. Validity test is used to determine the level of accuracy of an indicator questionnaire research question, in the ability to express the intentions submitted to respondents. The level of validation of this study is measured by using the total score correlation. Each question item score with its total score from all the items in question is declared valid, if the level of significance of the validity of the r count value is $> r$ table. The question item is declared invalid if the value of $r < r$ table. This study uses 5% significance with n amounting to 100 (because the number of respondents is 100 investors) then r table shows a value of 0.195.

Reliability test is used to measure the level of consistency of internal indicator questions from a contract in the study. The evaluation results from the reliability test use the value of Cronbach's Alpha. A question in the questionnaire is declared reliable or consistent if the cronbach's alpha value is > 0.60 , and is not reliable if the value of cronbach's alpha is < 0.60 (V Wiratna Sujarweni, 2014. SPSS for research, Yogyakarta: New Library Press. P. 193)
The results of the Pearson correlation validity test.

Table 1. Correlation and Realibility Test

	Indikator	1	2	3	4	Cronbach's Alpha	N of Item
Loss	X1.1	0.706				0.764	3
Aversion (X1)	X1.2	0.646					
	X1.3	0.759					
Regret	X2.1	0.903				0.728	3
Aversion (X2)	X2.2	0.811					
Illusion of control bias (X3)	X3.1			0.834			
	X3.2			0.874		0.802	4
	X3.3			0.883			
	X3.4			0.535			
Investment decision (Y)	Y1.1				0.562		
	Y1.2				0.451		
	Y1.3				0.606	0.811	6
	Y1.4				0.520		
	Y1.5				0.693		
	Y1.6				0.341		

Source: processed data

Based on Table 1 shows that the level of validation of each questionnaire question indicator from each loss aversion, regret aversion, illusion of control bias and investment decision has met the research requirements. This is because each question indicator value shows the total score correlation is more than r table 0.195. in conclusion the question indicators used in the loss aversion (X1) variable, regret aversion (X2), illusion of control bias (X3) and investment decision (Y) are valid.

Table 1 also shows that the results of the realibility test for each construct and the number of indicators show that the cronbach's alpha value is above 0.6. This shows that all indicator indicators show consistency or reliability.

Measurement Model Test. Performed to test the suitability of the model (goodness of fit) and the effect shown from the model. According to Ferdinand (2002: 55), determine the criteria for accepting or rejecting the model with several indexes of conformity and cut-off values. The results of the goodness of fit are presented in table 2.

Table 2. Evaluation of Goodness of Fit Indices Criteria Model one_Step Approach_Base Model

Goodness of Fit Index	Cut off value	criteria		
		saturated model	default model	Ev Model
χ^2 -Chi-square of estimate model			94.821	-
Probability Level	> 0.05	-	0.071	fit
CMIN/DF	≤ 2.00	-	1.128	fit
Goodness of Index (GFI)	≥ 0.90	1.000	0.901	fit
Adjusted Goodness of Index (AGFI)	≥ 0.90	-	0.928	fit
RMSEA	≤ 0.08	-	0.03	fit
Tucker-Lewis Index (TLI)	≥ 0.95		0.956	fit
Comparative Fit Index (CFI)	≥ 0.95		0.917	fit
Hoelter (0.05)	-	22	47	fit

Source: processed data

The evaluation results with the one step approach base model model from table 2 show all the goodness of fit criteria used are evaluations with fit models. χ^2 count value is 94.821 smaller than χ^2 table value of 101.879 and is supported by a probability value of 0.071 greater than the cut of value 0.05. both of these results indicate that the sample covariance matrix is not different or equal to estimation so it can be concluded that the model is considered fit.

CMIN / DF shows a value of 1.128 smaller than 2.00 (≤ 2.00 , cut off value) means the model also be fit. AGFI in this study shows that the calculated value in the default model is greater than the cut of value, which means that there is a level of acceptance recommended as a fit model. The results of the RMSEA evaluation, the calculation of this study is smaller than the determined cut-off value, concluded that the model is accepted as a close fit. The TLI and CFI calculated values show a value greater than the cut off value of 0.95 and the calculated value is close to 1, concluded as a very of good model. The Hoelter value shows the adequacy of the data used in the analysis. From the table it is known, that by default Hoelter value for the significance level of 0.05 is equal to 47 and greater than the value at the position of the independence model which is equal to 22, so the model is said to be valid.

Normality Evaluation. Normality test is used to find out the distribution of data from research whether in normal conditions or not. In this study, the normality test was evaluated using the SPSS normal P-P Plot and the Kolmogorov_Smirnov Test. The SPSS P-PPlot curve can be seen in Figure 1.

**Figure 1.** Curve P-P Plot

Figure 1, illustrates all the data depicted by following points and approaching the diagonal line so that it can be concluded that the model meets normality. P-P plot results is also supported by the Kolmogorov_Smirnov Test results in table 3.

Tabel 3. Kolmogorov_Smirnov Test

Information		Unstandardized Residual
N		100
Normal Parameters	Mean	0.00000
	Std Deviation	1.94770025
Most Extreme Differences	Absolute	0.087
	Positive	0.040
	Negative	-0.087
Test Statistic		0.087
Asymp sig (2-tailed)		0.058

Source: processed data

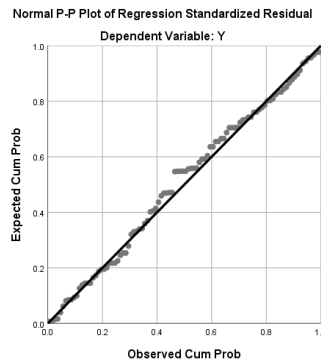
Table 3 shows that the data is normally distributed and supports the P-P plot results from Figure 1. This is indicated by the Kolmogorov_Smirnov Test result with the Asymp Sig (2_tailed) value of 0.058 and greater than 0.05 the significance limit.

Structural model evaluation. Covarian is the relationship between two variables that are two-way. In the model there are three covariances, the relationship between variables X1 and X2, the relationship between variables X2 and X3, and the relationship between variables X1 and X3. The results of statistical calculations show that the probability value X1 <--> X2 is 0.046 (<0.05); the probability value X2 <--> X3 is 0,000 (<0.05); and the probability value X1 <--> X3 is 0,000 (<0.05). Thus it can be concluded, there is a significant relationship between these variables. This can be seen from Figure 2.

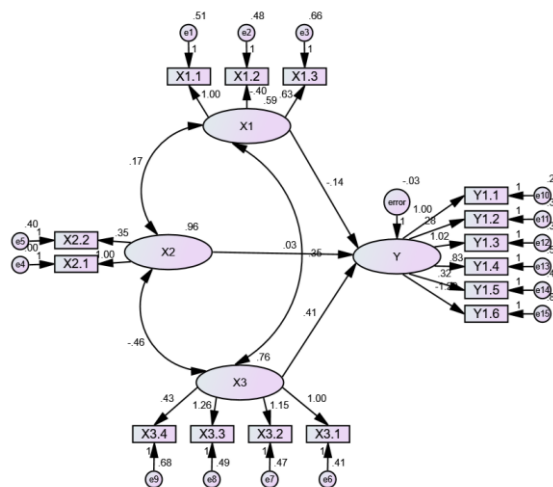

Figure 2. Structural model

Hypothesis testing. The result of the result hypothesis test can be seen from table 4.

Table 4. The Results Of The Causality Test

Factor	Factor	Estimate	S.E.	C.R	Prob
Y	← X1	0.396	0.042	0.725	0.046
Y	← X2	-0.388	0.074	-1.875	0.041
Y	← X3	0.408	0.082	4.998	0.000

Source: processed data

Information :

Y : Investment decision

X1 : Loss aversion

X2 : Regret aversion

X3 : Illusion of control bias

Based on table 4 shows that

1. The effect of the Loss aversion variable (X1) with the Investment decision variable (Y) is positively significant because the probability value (P) is 0.41 (<0.05).
2. The influence of the Regret aversion (X2) variable with the Investment decision variable (Y) is significantly negative, because the probability value (P) is 0.46 (<0.05)
3. The influence between the Illusion of control bias (X3) variable and the Investment decision variable (Y) is significantly positive, because the probability value (P) is 0.00 (<0.05).

Discussion

Loss aversion with the investment decision. The results of statistical tests show that loss aversion has a significant influence on investment decisions in a positive direction. These results do not support the hypothesis proposed in this study. This event illustrates that investors who are increasingly losing aversion are even more willing to take risks in making investment decisions. Loss aversion is one of the many psychological biases that influence investment decisions. The results of this study indicate that investors in KPKNL dare to invest by being influenced by psychological conditions and experience. The results of this study also show that most participants are investors in immovable assets. Investors see that investment in real assets, especially in immovable assets such as land, land and buildings will not lose because these assets have a value that continues to rise. This shows investors are not worried about the loss of assets bought and believe will bring profits. But investor behavior also seeks to invest when the price of the auctioned asset is valued at a low price because later the asset will make a bigger profit. When assets already owned have high prices in the market, investors tend to resist because they wait for higher prices to maximize profits. Loss aversion behavior in making investment decisions does not apply to real asset investors.

The results of this study are not in accordance with opinion of (Daniel Kahneman et al., 1990), (Haigh & List, 2005) who states that investors are more cautious and sensitive when loss compared to gain. The results of this study are also not in accordance with opinion of (D Kahneman & Tversky, 1979) in the theory of Prospect theory which states that people will hold back losses longer and will quickly sell shares when prices rise. This is because investors will try to avoid regret so deeply when they suffer losses. The best action to avoid remorse is to hold assets owned while waiting for prices to rise and good in the market so that when sold or released will benefit. The statement was as stated by (D Kahneman & Tversky, 1979), (Neale, NORTHCRAFT, BAZERMAN, & Alpers, 1986), (Seo, Goldfarb, & Barrett, 2010), Phuachan (2010) in (Yuniningsih Yuniningsih et al., 2017) where investors avoid losses and wait for the increase in stock prices in the future.

(D Kahneman & Tversky, 1979) state that someone who experiences loss aversion will determine how much risk taking is from the investment made. Investment domain problems can occur in conditions of domain or loss domain gain. Behavior in the problem domain will determine the size of the courage of investors to take risks in making investment decisions. Investors at KPKNL were not the same. Behavior of investors KPKNL shows courage to take risks in making investment decisions, before the fixed assets are owned even though the price of assets offered is high at auction. Especially if the price of fixed assets is offered at low prices, the behavior of investors will be more willing to take risks in making investment decisions. After the assets are owned by investors who win the auction at high prices. Investors tend to hold these assets for sale, waiting for prices to rise and get profit as desired. Individual psychological factors encourage investors to purchase these assets. Investors assume that the value of fixed assets will not go down and will continue to rise, eventually becoming a big profit as expected. Psychological aspects of KPKNL Investors take this action because they feel they have good knowledge of auctions and can properly manage investment finance. Other psychological aspects, investors feel knowing how to fluctuate in particular fixed asset prices which tend to be low but selling prices tend to rise. Investors also feel that they are able to make money budgets so they will dare to make investment decisions. The investor's behavior in making these decisions is not in accordance with what (D Kahneman & Tversky, 1979) said; (Neale et al., 1986), (Seo et al., 2010), Phuachan (2010) in (Yuniningsih Yuniningsih et al., 2017) states above.

Regret Aversion with the investment decision. The results of the regret aversion statistic test show a significant effect with a negative direction on investment decisions. These results support the hypothesis. Judging from the courage to take risks, the more investors regret aversion, the more afraid they will take risks in investment decisions. Regret aversion shows how investors avoid mistakes in the same decision explicitly because of the fear of taking action (Pompian, 2011). This shows that KPKNL investors have a feeling of worry about the prevailing price changes that have resulted in losses. Worries in investment losses that must be avoided. Regret aversion arises if investors want to avoid regret due to a wrong investment decision. The real action for KPKNL investors in regret aversion is to hold bad valuable assets and will sell valuable assets both to gain profits and avoid losses. In accordance with opinion of (Zeelenberg & Pieters, 2007), people's strategy to avoid regret is to delay the decision. Investors who postpone decisions according to the author are not something bad. Delays in decisions are made, to consider things carefully, to get accurate information first, and to avoid or minimize regrets. While other behaviors due to regret are escalation of commitment. According to (Staw, 1976), escalation of commitment illustrates that people who are increasingly committed to something will have negative consequences. People who are increasingly committed and loyal to certain things tend to override other things, especially those that are more useful, because of their risk taking behavior.

When the price of assets offered is low, the behavior of investors will make investment decisions by purchasing assets. The underlying psychological factor is the expectation that assets purchased at low prices will be sold at high prices to make a profit. Conversely, if the asset price is offered high, the behavior of investors tends not to act to make investment decisions. Investors assume, if the asset is sold, it will not get the maximum profit and even suffer losses. The condition of gain domain and domain loss is what determines behavior to act or not act in investment decisions. Domain gain and loss conditions will also determine the fear of asset losses. Investors will be more careful in determining the same decisions especially those who have experienced losses. According to (Pompian, 2011) regret aversion causes investors to act conservatively and over anticipate if market prices continue to fall. The Regret aversion phenomenon gives rise to regret theory developed

by (Loomes & Sugden, 1982) and (Bell, 1982). Regret Theory (Loomes & Sugden, 1982) and (Bell, 1982) are considered irrational theories of choice in conditions of uncertainty.

Illusion of control bias with the investment decision. The results of the statistical test variable Illusion of control bias show a significant influence on investment decisions. It can be concluded that the results of the study support the hypothesis. (Pompian, 2011) states that illusion of control bias describes the tendency of humans who believe in the ability to control and influence outcomes, even though in reality, they cannot control it. Investors who have high trust in their abilities tend to be more courageous in making investment decisions and vice versa.

Investors who tend to have high illusion of control behavior are more willing to make investment decisions. Investors with illusion of control bias feel mastered the knowledge, have complete information and are very active in investing, especially in auction activities. KPKNL investors whose behavior tends to be illusion of control bias will be brave enough to take a buying decision even though the price offered is high, even more daring at low price and will quickly release or resell if there is slight increased price. The courage to make an investment occurs because the investor feels that he is able to resell at a high price, even though in reality he cannot fully control what he expected. Conversely, investors who actually have good knowledge and high analytical skills will make more careful decisions. Low bias illusion of control investors are not because they are not confident, but have measurable confidence based on mature facts and considerations. KPKNL investors who are included in the low illusion of control bias, when the bidding price is low or high, will not make investment decisions quickly. The investor must consider the type of asset offered. Especially for assets other than land and buildings must be considered as much as the economic age of the asset, how much the damage is, how much the repair cost is before resale, what price is on the market. Land and building assets that must be considered are the clarity of ownership documents, the amount of tax to be borne, the location of the land and buildings, and the ease of access to the location. Investors must learn accurate information about the assets to be auctioned as detailed as possible before making an investment decision. Psychological factors play an active role in making investment decisions. Many psychological indicators, especially in illusion of control bias, must be considered. For example, how successful a person is in the past, the more successful the past is, the more courageous to make decisions. Despite previous successes, investors must continue to pay attention to the latest information. Another indicator is that investors are used to investing. This is what encourages investors to feel very capable and confident in making investment decisions. The more certain investors are able to overcome all the problems that exist, the more courageous they will make investment decisions, and vice versa. However, all decisions that will be made must be properly considered, taking into account the past, present and future information both related and unrelated.

CONCLUSION

Investors' investment decision making is largely influenced by many factors, both internal and external, both from fundamental and psychology. The loss aversion factor is not as hypothesized because the more loss aversion the more risk-taking in deciding to invest. This is because of the urge to get bigger profits assuming asset prices will continue to rise. Regret aversion of real asset investors is the same as what happened to the financial asset investors in accordance with what was hypothesized. As long as the asset is seen as a large loss and recurring to the same asset, investors tend not to invest. Illusion of control bias in this study is very influential in making investment decisions compared to loss aversion and regret aversion. This happens because Illusion of control can have the smallest significant value compared to both. Low illusion of control investors show that

people tend to use ratios compared to negative emotions. Investors who use more ratios have more factors to consider before deciding to invest. Whether or not investors take risks in deciding investments is much influenced by the level of psychology that each individual has.

Acknowledgments. The author said thank you to the Indonesian Ministry of Research and Technology Ministry and LPPM of East Java UPN "Veteran" who funded and provided opportunities for research. The author also thanked the Office of State Wealth and Auction Services (KPKNL) Sidoarjo, East Java, Indonesia for giving permission to conduct research.

REFERENCES

- Ackert, L. F., Church, B. K., & Deaves, R. (2003). Emotion and financial markets. *Federal Reserve Bank of Atlanta Economic Review*, 88(2).
- Anderson, C. J. (2003). The psychology of doing nothing: forms of decision avoidance result from reason and emotion. *Psychological Bulletin*, 129(1), 139.
- Bell, D. E. (1982). Regret in decision making under uncertainty. *Operations Research*, 30(5), 961–981.
- Haigh, M. S., & List, J. A. (2005). Do professional traders exhibit myopic loss aversion? An experimental analysis. *The Journal of Finance*, 60(1), 523–534.
- Hoffman, C. A. (1972). The venture capital investment process: A particular aspect of regional economic development. University of Texas at Austin.
- Kahneman, D. (1979). Prospect theory: An analysis of decisions under risk. *Econometrica*, 47, 278.
- Kahneman, D., Knetsch, J. L., & Thaler, R. H. (1990). Experimental tests of the endowment effect and the Coase theorem. *Journal of Political Economy*, 98(6), 1325–1348.
- Kahneman, D., & Tversky, A. (1979). An analysis of decision under risk [J]. *Econometrica: Journal of the Econometric Society*, 47(2).
- Landstrom, H. (1995). A pilot study on the investment decision-making behavior of informal investors in Sweden. *Journal of Small Business Management*, 33(3), 67.
- Levy, J. S. (1992). An introduction to prospect theory. *Political Psychology*, 171–186.
- Lintner, G. (1998). Behavioral finance: Why investors make bad decisions. *The Planner*, 13(1), 7–8.
- Loomes, G., & Sugden, R. (1982). Regret theory: An alternative theory of rational choice under uncertainty. *The Economic Journal*, 92(368), 805–824.
- Malkiel, B. G., & Fama, E. F. (1970). Efficient capital markets: A review of theory and empirical work. *The Journal of Finance*, 25(2), 383–417.
- Mittal, M. (2010). Study of differences in behavioral biases in investment decision-making between the salaried and business class investors. *IUP Journal of Behavioral Finance*, 7(4), 20.
- Neale, M. A., NORTHCRAFT, G. B., BAZERMAN, M. H., & Alpers, C. (1986). CHOICE SHIFT EFFECTS IN GROUP DECISIONS-A DECISION BIAS PERSPECTIVE. *International Journal of Small Group Research*, 2(1), 33–42.
- Nofsinger, J. R. (2011). *The psychology of investing*. Prentice Hall 4th edn. Boston, MA.
- Pavabutr, P. (2002). Investor Behavior and Asset Prices. In Sangvien Conference.
- Pertiwi, T., Yuniningsih, Y., & Anwar, M. (2019). The biased factors of investor's behavior in stock exchange trading. *Management Science Letters*, 9(6), 835–842.
- Pompian, M. M. (2011). Behavioral finance and wealth management: how to build investment strategies that account for investor biases (Vol. 667). John Wiley & Sons.
- Ritov, I., & Baron, J. (1990). Reluctance to vaccinate: Omission bias and ambiguity. *Journal of Behavioral Decision Making*, 3(4), 263–277.

- Seo, M.-G., Goldfarb, B., & Barrett, L. F. (2010). Affect and the framing effect within individuals over time: Risk taking in a dynamic investment simulation. *Academy of Management Journal*, 53(2), 411–431.
- Shiller, R. J. (2003). From efficient markets theory to behavioral finance. *The Journal of Economic Perspectives*, 17(1), 83–104.
- Staw, B. M. (1976). Knee-deep in the big muddy: A study of escalating commitment to a chosen course of action. *Organizational Behavior and Human Performance*, 16(1), 27–44.
- Subash, R. (2012). Role of behavioral finance in portfolio investment decisions: evidence from India.
- Thaler, R. H., Tversky, A., Kahneman, D., & Schwartz, A. (1997). The effect of myopia and loss aversion on risk taking: An experimental test. *The Quarterly Journal of Economics*, 112(2), 647–661.
- Tykocinski, O., Israel, R., & Pittman, T. S. (2004). Inaction Inertia in the Stock Market 1. *Journal of Applied Social Psychology*, 34(6), 1166–1175.
- Wong, K. F. E., & Kwong, J. Y. Y. (2007). The role of anticipated regret in escalation of commitment. *Journal of Applied Psychology*, 92(2), 545.
- Wulandari, D. A., & Iramani, R. (2014). Studi Experienced Regret, Risk Tolerance, Overconfidance Dan Risk Perception Pada Pengambilan Keputusan Investasi. *Journal of Business & Banking*, 4(1), 55–66.
- Yuniningsih, Y., Pertiwi, T., & Purwanto, E. (2019). Fundamental factor of financial management in determining company values. *Management Science Letters*, 9(2), 205–216.
- Yuniningsih, Y., Taufiq, M., Wuryani, E., & Hidayat, R. (2019). Two stage least square method for prediction financial investment and dividend. In *Journal of Physics: Conference Series* (Vol. 1175, p. 12212). IOP Publishing.
- Yuniningsih, Y., Widodo, S., & Wajdi, M. B. N. (2017). An analysis of Decision Making in the Stock Investment. *Economic: Journal of Economic and Islamic Law*, 8(2), 122–128.
- Zeelenberg, M., & Pieters, R. (2007). A theory of regret regulation 1.0. *Journal of Consumer Psychology*, 17(1), 3–18.

