

The analysis of the pharyngeal-sieve mechanism and the efficiency of food intake in the bream (*Abramis brama*, Cyprinidae)

Cover design: Wim Valen



40951

Promotor: dr. J.W.M. Osse, hoogleraar algemene dierkunde

Co-promotoren: dr. E.H.R.R. Lammens, wetenschappelijk onderzoeker bij het
Limnologisch Instituut van de Koninklijke Nederlandse Academie
van Wetenschappen

dr. F.A. Sibbing, universitair hoofddocent algemene dierkunde

UNO8201, 1454

Willem Hoogenboezem

***THE ANALYSIS OF THE PHARYNGEAL-SIEVE MECHANISM AND THE
EFFICIENCY OF FOOD INTAKE IN THE BREAM (Abramis brama, Cyprinidae)***

Proefschrift

ter verkrijging van de graad van doctor
in de landbouw- en milieuwetenschappen
op gezag van de rector magnificus,
dr. H.C. van der Plas,
in het openbaar te verdedigen
op woensdag 4 december 1991
des namiddags te vier uur in de aula
van de Landbouwuniversiteit te Wageningen.

UN 551298

Voor Tineke, Daphne en Remco

Het onderzoek dat in dit proefschrift wordt beschreven werd mogelijk gemaakt door een subsidie van NWO/Stichting BION (beleidsproject 437.241 B) aan Prof. Dr. J.W.M. Osse (LUW) en Dr. J. Vijverberg (Limnologisch Instituut, KNAW), werkgroepeliders van de werkgroep Morfologie van Mens en Dier respectievelijk Aquatische Oecologie. Door vertraging van dit project in het eerste jaar werd deze subsidie aangevuld door LUW en KNAW waardoor verlenging met 1 jaar mogelijk werd gemaakt.

Stellingen

- 1 De brasem maakt bij het foerageren achtereenvolgens de volgende keuzen: benthisch of pelagisch; "particulate-" of "filter-feeding" en in het laatste geval met of zonder gereduceerde kieuwfilter kanalen (dit proefschrift).
- 2 De prooi-grootte selectie bij zoöplanktivore brasem wordt voor een belangrijk deel bepaald door de "feeding-mode" (Janssen, 1976; dit proefschrift).
- 3 De grootte verdeling van het beschikbare zoöplankton beperkt de maximale grootte van de brasem in de nederlandse eutrofe wateren tot ca. 50 cm standaard lengte (dit proefschrift).
- 4 Brasem van 15-25 cm standaard lengte kan, afhankelijk van de grootte-verdeling van het aanwezige zoöplankton, de maaswijdte van het kieuwfilter op twee standen instellen. Grotere exemplaren zijn genoodzaakt voortdurend met de fijnste zeefinstelling te filteren (dit proefschrift).
- 5 Het kieuwzeef apparaat van de brasem is voorzien van een uitgebreid systeem van zenuwvezels en zintuigcellen. Het verdient aanbeveling de betekenis van dit systeem voor de sturing van de intra-orale verwerking van het voedsel nader te onderzoeken.
- 6 De efficiëntie van voedselopname van brasem tijdens het foerageren in bodemmateriaal blijkt afhankelijk te zijn van de korrelgrootte van het substraat (Lammens et al., 1987). Deze waarneming is een aanwijzing dat de brasem ook tijdens het bodem-foerageren gebruik maakt van de filter-kanalen.
- 7 Het feit dat brasem zo snel heeft kunnen profiteren van het verhoogde zoöplankton aanbod is waarschijnlijk het gevolg van pre-adaptatie.

- 8 Bij filterende organismen wordt een homogene grootte-verdeling van de mazen verwacht (Boyd, 1976, dit proefschrift.
- 9 Koppeling van functioneel-morfologische en autoecologische analyse van een soort is noodzakelijk om de structurele aanpassingen op te sporen en hun betekenis voor overleving op de juiste waarde te schatten.
- 10 Dieren, waarbij de onderlinge herkenning visueel geschiedt zijn voor de mens gemakkelijker te onderscheiden dan soorten waarbij andere zintuigen een dominante rol spelen (cf. vogels en vleermuizen).
- 11 Het aantal overdrukken dat bij de auteur wordt aangevraagd is omgekeerd evenredig met de verspreiding van het tijdschrift waarin het artikel werd gepubliceerd. Het aantal aanvragen is dus geen betrouwbare maat voor de kwaliteit van het artikel.
- 12 Oplossingen zijn een bron voor problemen.

Referenties

- Boyd, C.M. 1976. Selection of particle sizes by filter-feeding copepods: a plea for reason. *Limn. Oceanogr.* 21: 175-180.
- Janssen, J. 1976. Feeding modes and prey size selection in the Alewife (*Alosa pseudoharengus*). *J. Fish. Res. Bd. Can.* 33: 1972-1975.
- Lammens, E.H.R.R., J. Geursen and P.J. McGillivray. 1987. Diet shifts, feeding efficiency and coexistence of bream (*Abramis brama*), roach (*Rutilus rutilus*), and white bream (*Blicca bjoerkna*) in hypertrophic lakes. *Proc. Vth congress Europ. Ichthyol. Stockholm 1985*, 153-162.

Stellingen behorend bij het proefschrift "*The analysis of the pharyngeal-sieve mechanism and the efficiency of food intake in the bream (Abramis brama, Cyprinidae).*"
Door Wim Hoogenboezem. Wageningen, 4 december 1991.

INHOUDSOPGAVE/CONTENTS

	Pag.
Inleiding	7
Samenvatting	19
Summary	21
1 Diets and Feeding behaviour. E.H.R.R. Lammens and W. Hoogenboezem. In I.J. Winfield and J. Nelson (ed.). Cyprinid fishes systematics, biology and exploitation. Chapman and Hall, London, pp: 353-376 (1991).	23
2 X-ray measurements of gill-arch movements in filter feeding bream, <u>Abramis brama</u> (Cyprinidae). W. Hoogenboezem, F.A. Sibbing, J.W.M. Osse, J.G.M. v.d. Boogaart, E.H.R.R. Lammens and A. Terlouw. J. Fish Biol. 1990: 36, 47-58.	47
3 A new model of particle retention and branchial sieve adjustment in filter-feeding bream (<u>Abramis brama</u> , Cyprinidae). W. Hoogenboezem, J.G.M. v.d. Boogaart, F.A. Sibbing, E.H.R.R. Lammens, A. Terlouw and J.W.M. Osse. Can. J. Fish. Aquat. Sci. Vol. 48, 1991.	59
4 A model for switching between particulate-feeding and filter-feeding in the common bream <u>Abramis brama</u> . W. Hoogenboezem, E.H.R.R. Lammens, Y. v. Vugt and J.W.M. Osse. Env. Biol. Fish. 1991.	71
5 Prey-size selectivity and sieve adjustment in filter-feeding bream (<u>Abramis brama</u> (L), Cyprinidae). W. Hoogenboezem, E.H.R.R. Lammens, P.J. MacGillavry and F.A. Sibbing. Submitted to: Can. J. Fish. Aquat. Sci.	85
6 Mucus in filter-feeding of bream (<u>Abramis brama</u>). W. Hoogenboezem and J.G.M. v.d. Boogaart. Submitted to: Can. J. Fish. Aquat. Sci.	99
Dankwoord	118
Curriculum vitae	120
	5

INLEIDING

Onderzoek van Lammens et al. (o.a. 1984; 1985; 1986) heeft laten zien dat brasem (*Abramis brama*) naast op bodemdieren ook heel goed kan foerageren op zoöplankton. Sibbing et al. (1982; 1984; 1987; 1988; 1991) tonen aan dat de morfologie van het voedsel-apparaat van karperachtige vissen vele mogelijkheden biedt om voedsel te verzamelen. Het lag voor de hand de functioneel morfologische en oecologische aanpak samen te voegen om het mechanisme van de voedselopname bij de brasem te bestuderen.

Een belangrijke reden om het mechanisme van de voedselopname, de werking van de kieuwzeef en het fourageer gedrag, van brasem te bestuderen is de enorme toename van deze soort in de eutrofe Nederlandse binnenwateren (Lammens, 1986). Een complex van factoren vergezelt deze toename, zoals bijvoorbeeld: toename van de hoeveelheid beschikbaar voedsel; vermindering van de helderheid van het water; vervanging van snoek door snoekbaars; vermindering van de macrofyten vegetatie; verandering van visserij beleid. De meeste van deze veranderingen kunnen in verband worden gebracht met de eutrofiering van het oppervlakte water. Brasem heeft van het toegenomen voedselaanbod geprofiteerd, met name van het zoöplankton (Lammens, 1986). Vóór deze toename fourageerden brasems voornamelijk op in de bodem levende insekte-larven (o.a. Chironomidae) en kleine kreeftachtigen (benthische cladoceren).

De vraag is nu waarom juist brasem het meest van de nieuwe voedselomstandigheden profiteerde. Het ligt voor de hand te veronderstellen dat het domineren van brasem samenhangt met het efficiënter gebruik van de nieuwe voedselbron. Het verschil in exploitatie van het zoöplankton moet gezocht worden in het foerageer gedrag en/of de werking van het kieuwzeef apparaat. Uit de literatuur (zie b.v. Lazzaro, 1987) bleek dat er al vrij veel bekend is over voedselselectie bij vissen. Informatie over de bouw van kieuwfilters is echter al veel schaarser (Zander, 1906; Gibson, 1988, Lammens, 1984), terwijl de kennis over de feitelijke werking van het kieuwzeef apparaat vrijwel geheel ontbreekt. Deze leemte kan worden opgevuld door methoden en technieken uit de oecologie en de functionele morfologie te integreren, om zo tot een werkelijk oecomorfologische benadering van het probleem te komen.

Hoofdstuk 1

In dit hoofdstuk wordt een overzicht gegeven van de voedselsoorten en foerageertechnieken voor karperachtigen (Cyprinidae), tevens wordt hier de oecologische plaats van brasem nader bepaald. De eerste resultaten van dit project worden hier besproken en vergeleken met wat er in de literatuur is beschreven.

Jansen (1976) beschrijft drie methoden van voedselopname "particulate feeding", "pumpfilter-feeding" en "tow-net filter-feeding". Particulate feeding is een strategie waarbij de vis de prooi individueel lokaliseert en gericht opneemt. Pump filter feeding is een techniek waarbij de vis periodiek en ongericht een hoeveelheid water opneemt en deze zeeft. Bij deze techniek wordt de selectiviteit voornamelijk bepaald door de maaswijdte van de zeef. Tow-net filter-feeding is een techniek die (nog) niet voor Cyprinidae is beschreven, waarbij de vis met wijd geopende bek zwemt en de prooien uit het water zeeft. Ook hier wordt de selectiviteit voornamelijk door de maaswijdte van de kieuwzeef bepaald.

Hoofdstuk 2

De kieuwzeef van brasem bestaat uit vijf paar kieuwbogen, waarbij zich op de eerste vier paren telkens 2 rijen kieuwdoornen (branchiospinae; eng. Gill-rakers) bevinden (Fig. 1, hfd. 3), terwijl het vijfde paar bogen voornamelijk dient als keelkaak en is voorzien van slechts een enkele rij lateraal geplaatste kieuwdoornen (Sibbing 1982). Wanneer we de bogen met hun kieuwdoornen op een vlak geprojecteerd denken ontstaan spleten met een zaagtand patroon. Het "zaagtand karakter" van de spleten wordt veroorzaakt door het ineengrijpen van de kieuwdoorns van beide kieuwbogen (Zander 1906, Lammens 1984, Sibbing, 1991). Het bestaande model van de werking van de kieuwzeef ging er van uit dat de vis door het instellen van de breedte van deze spleten de maaswijdte van de zeef zou kunnen aanpassen. Brasem zou op deze wijze de zeef kunnen instellen in afhankelijkheid van het voedselaanbod.

Dit model werd getoetst door de breedte van de kieuwspleten bij foeragerende brasems te meten met behulp van röntgenfilms. Door de daarvoor in aanmerking komende onderdelen van de kieuwzeef en de kop van Platina markeringen te voorzien, was het mogelijk via afzonderlijke filmbeelden de bewegingen binnen in de vis te reconstrueren. Volgens het zaagtand-model zouden de spleten tijdens het foerageren kleiner moeten

blijven dan de prooien om verlies van deeltjes te voorkomen. De bewegingspatronen van de kieuwbogen bij een "ademende" vis en tijdens de voedselopname werden hiermee voor het eerst beschreven. Uit de opnamen bleek dat de spleetbreedte duidelijk groter was dan de prooien waarop de vis foerageerde. Het gebruikte model bleek dus niet geschikt voor de beschrijving van het werkingsmechanisme van de kieuwzeef van de brasem, en moet worden verworpen. De vraag hoe het filtermechanisme dan wel werkt bleef echter onduidelijk.

Hoofdstuk 3

In hoofdstuk 3 wordt een nieuw model voor het filtermechanisme en de maaswijdte regulatie ontwikkeld. Het model is gebaseerd op de driedimensionale bouw van de kieuwzeef. Een nieuwe hypothese was dat voedsel deeltjes uit het water worden gezeefd in kleine kanaaltjes (channels) die zich op de bovenzijde en flanken van de kieuwboog bevinden. Het water met voedseldeeltjes wordt door de nauwe mondspleet tussen kieuwzeef en palataal orgaan (bekleding van het monddak, cf. Sibbing, 1988; 1991) gestuwd en naar de kanaaltjes gevoerd, waar de retentie van de deeltjes plaatsvindt.

Histologische coupes van kieuwboog materiaal leerden dat er minuscule dwarsgestreepte (willekeurige) spiertjes aan de lateraal gelegen kieuwdoornen verbonden zijn. We veronderstellen dat deze spiertjes een rol spelen bij het reguleren van de feitelijke maaswijdte van de zeef. De hypothese is dat de punt van de kieuwdoorn m.b.v. deze spiertjes in de mediale uitstroom-opening van een filterkanaal, op de ernaast gelegen kieuwboog, kan worden gebracht en de effectieve maaswijdte van dat kanaal halveert (gereduceerde kanaaldiameter, Fig. 9; hfd. 3). Bij het fourageren op grotere prooidieren zou de brasem zonder hulp van de beweeglijke kieuwdoorn kunnen fourageren (ongereduceerde kanaaldiameter).

Volgens de nieuwe hypothese van het filter mechanisme zou aan de volgende voorwaarden moeten worden voldaan:

- de mondspleet is tijdens het foerageren nauw;
- voedseldeeltjes moeten aantoonbaar zijn in de beschreven kanalen;
- een opgenomen voedseldeeltje moet een baan evenwijdig aan de kieuwboog volgen en vervolgens een scherpe bocht maken (ca 90°) als het in het kanaal komt, waar het vervolgens wordt tegengehouden;

- de in hoofdstuk 2 beschreven spleten tussen de kieuwbogen, dienen tijdens het foerageren niet breder te zijn dan de lengte van de beweeglijke laterale kieuwdoorn;
- de meeste voedseldeeltjes moeten in de mediaal op de kieuwboog gelegen kanalen worden gevonden.

Het onderzoek toonde aan dat er inderdaad voedsel-deeltjes in de kanalen gevonden werden, met name in de mediale kanalen. Met behulp van röntgenfilms werd aangetoond dat er sprake is van een nauwe mondspleet (ca. 2 mm), tijdens de opname van kleine deeltjes. Ook de baan die het opgenomen (gemarkeerde) voedseldeeltje volgt voldoet aan de verwachting. Tenslotte bleek de lengte van de laterale kieuwdoorn precies in overeenstemming met de eerder waargenomen spleten tussen de kieuwbogen.

Hoofdstuk 4

Enkele malen is al melding gemaakt van de verschillende foerageertechnieken (feeding-modes) waarvan brasem en andere zoöplanktivore vissen gebruik maken. Het omschakelen van de ene "feeding-mode" op de andere hangt niet alleen samen met het voedselaanbod, maar ook met de grootte van de vis. In dit hoofdstuk wordt het overschakelen van de ene foerageerstrategie naar de andere beschreven (Jansen, 1976; Holanov & Tash, 1978; Crowder, 1985; Gibson & Ezzi, 1985; Lazzaro, 1987; Lammens, 1985). Er wordt een nieuw model ontwikkeld dat de omschakeling van "particulate-feeding" (PF) naar "filter-feeding" (FF) beschrijft. Als de zoöplankton-dichtheid hoog is kan een brasem voedseldeeltjes opzuigen zonder er gericht naar te hoeven zoeken. Indien het mondvolume en de prooidichtheid groot genoeg zijn, zodat bij elke hap zelfs enkele deeltjes kunnen worden opgenomen is FF waarschijnlijker dan PF. Dit principe vormt de basis van het ontwikkelde model. De (enigszins arbitraire) aanname is dat als elke "random" hap tenminste één voedsel deeltje oplevert de brasem overschakelt van PF naar FF. We nemen aan dat de verdeling van zoöplanktondeeltjes random is. De verhouding van de gemiddelde hoeveelheid water (GW) rond elke prooi en het mondvolume (BV) van de foeragerende vis bepaalt wanneer per hap een of meer deeltjes worden opgezogen ($BV/GW > 1$). Omdat er geen "zoektijd" nodig is bij filter-feeding verwachten we hier een constant aantal happen per tijdseenheid.

Bij een ratio $BV/GW < 1$ zal de vis gericht deeltje voor deeltje opnemen (PF), omdat het energieverlies zou zijn happen te nemen die geen enkel deeltje bevatten. De

hapfrequentie is afhankelijk van het aantal prooien dat per tijdseenheid wordt ontmoet en dus van de zwemsnelheid ($V \text{ m*s}^{-1}$) van de vis. Bij een gegeven prooidichtheid kan de gemiddelde afstand tussen de prooien (D) worden geschat. Wanneer we aannemen dat de vis naar elke ontmoete prooi zal happen, dan is de gemiddelde hapfrequentie (SF) uit de inter-prooiafstand en de gemiddelde zwemsnelheid (V in cm/s) te berekenen:

$$SF = V \cdot D^{-1} \text{ (happen per seconde).}$$

De zwemsnelheid van de prooidieren is, vergeleken met die van de vis, erg klein en wordt in dit model verwaarloosd. Het mondvolume (buccal volume; BV) hangt af van de grootte van de vis. Een vis neemt water op door de mondholte te expanderen, waardoor het water door de zich openende bek naar binnen zal stromen. Door simultaan filmopnamen te maken in ventraal en lateraal aanzicht van een foeragerende vis kan de buccale expansie worden bepaald (Drost & van den Boogaart, 1986). Ik heb dergelijke metingen uitgevoerd aan vissen van verschillende grootte (8-45 cm S.L.). Uit deze metingen bleek een verband (zie Fig. 4; hfd. 4), waarmee voor elke grootte brasem het mondvolume te bepalen is.

Voor de toetsing van het model werd via een voedsel-doseeropstelling (zie Fig. 1, hfd. 4) een bekende hoeveelheid levend zoöplankton over het aquarium verdeeld. Met behulp van video-opnamen werd de hapfrequentie van de brasem bij een bepaalde prooidichtheid bepaald.

De resultaten van deze bepalingen laten zien dat er een toename van hapfrequentie is met toename van het voedselaanbod, zoals het model voorspelt. Uit het model valt af te leiden dat grote brasems al bij de voorspelde lage dichtheden van PF naar FF kunnen overschakelen (Fig. 3^{A, B, C, D}; hfd. 4). De waarnemingen tonen inderdaad een constante hapfrequentie, bij dichtheden hoger dan de "switch-dichtheid" (Fig. 3^{E, F}; hfd. 4).

De toename van het mondvolume van grotere brasems maakt dat er per prooi meer water moet worden opgezogen. Omdat het opnemen van water energie kost, kan het voor grotere brasems energetisch ongunstig zijn particulate feeder te zijn omdat de energie investering hoger uitkomt dan de feitelijke opbrengst. Foerageren wordt voor grotere vissen pas rendabel wanneer er per (random) hap een aantal prooien tegelijk kunnen worden opgenomen. Dit werd bevestigd door de waarneming dat een brasem van 29,5 cm slechts zelden foerageerde bij lage dichtheden. Dit eenvoudige model laat zien welke

factoren van belang zijn voor de vis wanneer er voor een bepaalde foerageerstrategie gekozen moet worden.

Hoofdstuk 5

Dit hoofdstuk beschrijft de kwantitatieve toetsing van het kanalenmodel uit hoofdstuk 3 met behulp van voedselproeven. Bij deze experimenten werd een bekende hoeveelheid zoöplankton met een bekende grootte-verdeling aan een brasem aangeboden. Nadat het dier enige tijd, meestal enkele uren, heeft kunnen foerageren werd de samenstelling van het zoöplankton opnieuw bepaald. Uit het verschil tussen beide tijdstippen kan worden bepaald hoeveel prooien de proefvis per grootte-klasse heeft gegeten. Met deze informatie kan de efficiëntie, waarmee prooien van bepaalde grootte worden tegengehouden, worden gemeten (retentiekans). Om de optische keuze van de vis uit te sluiten is een aantal proeven in absolute duisternis uitgevoerd.

Toetsing van het kanalenmodel m.b.v. voedselproeven is alleen mogelijk indien we een op dit model gebaseerde kwantitatieve voorspelling van de selectiviteit kunnen doen.

Tenminste drie factoren bepalen de retentiekans van een deeltje in een zeef: a) de maaswijdte en de homogeniteit van het filter, d.w.z. hoe gelijkvormiger de mazen van een zeef hoe scherper de retentie-karakteristiek (Boyd, 1976; Rubinstein & Koehl, 1977) b) de grootte en de vorm van het deeltje en c) de oriëntatie van het deeltje ten opzichte van de maas van de zeef, een langwerpige voorwerp kan b.v. niet dwars door de maas maar wel in de lengterichting. Dit laatste is er de oorzaak van dat het onmogelijk is de discrete retentiekans te bepalen. Er kan echter wel gesproken worden van een gemiddelde retentiekans. De gemiddelde retentiekans van watervlooien (*Daphnia spec.*) t.o.v. zeven met bekende maaswijdte is bepaald. Als men aanneemt dat de vorm van een watervlo tijdens de groei niet wezenlijk verandert (iso-metrische groei), dan zal het voor de retentiekans niet verschillen of een kleine watervlo over een zeef met kleine mazen wordt gezeefd of een grote over een proportioneel grotere zeef. Dit heeft als gevolg dat er een relatie moet bestaan tussen de retentiekans enerzijds en de grootte van de prooi (L) en de maaswijdte (M) van de zeef anderzijds. Deze relatie, verder aangeduid als L/M-ratio, is gebruikt om de retentiekans per grootte-klasse van de prooi te berekenen. De mazen waarmee de L/M-ratio werd bepaald zijn vierkant, terwijl de mazen in de kieuwzeef

duidelijk geronde kanalen zijn. Voor de model berekening van de maaswijdte van de kieuwzeef is de breedte van het kanaal gebruikt in de L/M-ratio.

De homogeniteit van het filter van de brasem werd bepaald door de breedte van alle kanalen in de kieuwzeef te bepalen. Vooral de kanalen die dicht bij het palataalorgaan liggen zijn duidelijk kleiner dan meer centraal gelegen kanalen maar ook de kanalen op de bogen III en IV zijn kleiner dan die op de eerste twee bogen. Uit de metingen van de kieuwboog-afstanden (hfd. 2) kon worden afgeleid dat ca. 90% van het water door de eerste twee spleten (tussen de bogen I-II 68% en II-III 22%) moet stromen. Het is daarom gerechtvaardigd dat er in de berekeningen een constante kanaalbreedte (mediale kanalen van boog I) wordt gebruikt.

De relatie tussen de grootte van de vis en de kanaaldiameter werd bepaald bij een aantal dieren variërend van 8 tot 45 cm standaard lengte. Van deze exemplaren werd de breedte van een aantal mediale kanalen van de eerste kieuwboog bepaald (cf. van den Berg et al. 1991).

Uit het verschil in dichtheid van de grootste *Daphnia*'s tussen begin en eind van een voedsel proef kon worden afgeleid hoeveel water er door de vis gefilterd was. Aannemende dat er een random verdeling van prooien is en dat de vis het water random zeeft, is dus te berekenen hoeveel prooien er in de bek van de proefvis zijn gekomen. Door toepassing van de hierboven afgeleide theoretische retentiekans kon worden voorspeld welke fractie van het zoöplankton zou worden opgegeten.

Vergelijking tussen de voorspelde en de waargenomen retentie-curven vertoonde goede overeenkomsten. Vissen van 18,0-23,5 cm S.L. bleken soms met ongereduceerde en soms met gereduceerde kanalen te foerageren (Fig. 3A, 3B; hfd. 5). De relatie tussen voedselaanbod en filteren met een bepaalde zeefinstelling bleek niet eenduidig uit mijn experimenten. De grootste brasems (30,0-34,5 cm S.L.) filterden altijd met gereduceerde kanalen (Fig. 4; hfd. 5). Bij deze exemplaren zijn de kanalen te groot om ongereduceerd relatief klein zoöplankton tegen te houden.

Hoofdstuk 6

Als de voedseldeeltjes in de kieuwzeef zijn gevangen moeten ze nog naar de slokdarm worden getransporteerd. Zoals in hoofdstuk 2 werd beschreven, zijn er tijdens het foerageren tussen de kieuwbogen vrij grote spleten aanwezig, waardoor de kleine prooi-

deeltjes gemakkelijk verloren kunnen gaan. Het transport van gevangen kleine voedseldeeltjes blijkt te geschieden met behulp van slijm. Aan slijm gebonden zoöplankton werd aangetroffen in het achterste deel van de mondholte, meestal ter hoogte van kieuwbogen 3, 4, en 5. Om de rol van het slijm bij de voedselopname te bepalen werd een groot aantal vers verzamelde brasems onderzocht op het voorkomen van zgn. slijm-bolussen. Het bleek dat bij een groot aantal (soms tot 77% van de gevangen dieren) brasems slijmbolussen in de mondholte aanwezig zijn. Aan slijm gebonden zoöplankton werd veel waargenomen, een enkele maal werden ook kleine chironomide-larven (ca 50 exemplaren) in buccaal slijm aangetroffen. Er werd tevens een gedetailleerde histologische studie gemaakt van de kieuwzeef en het palataal orgaan, waarbij de aantallen slijmproducerende cellen in de verschillende delen van de kieuwzeef werden bepaald. Dit leverde inzicht in de verdeling en aantallen van de slijm producerende cellen, waarbij een gradueel toenemende celdichtheid in caudale en mediale richting werd aangetoond. Dit leidde tot de ontwikkeling van een model dat de rol van slijm bij de voedselopname beschrijft.

Uit de voedsel proeven is gebleken dat brasem grootte-selectief is: onder bepaalde omstandigheden worden deeltjes van een bepaalde grootte wel gegeten, terwijl dezelfde vis bij een andere voedselsamenstelling deze deeltjes niet in de kieuwzeef vasthoudt. Hieruit kan worden geconcludeerd dat het slijm niet dient om de voedseldeeltjes tegen te houden in het zeefapparaat. Een histologische doorsnede van een slijm bolus (Fig.2A, 2B; hfd. 6) laat duidelijk zien dat de individuele prooien omgeven zijn door een laagje slijm. het mechanisme van de voedselopname wordt nu als volgt voorgesteld:

- 1) een hoeveelheid water, inclusief de voedseldeeltjes wordt opgenomen en de prooien worden in de kanalen (mechanisch) tegengehouden, zonder hulp van het slijm.
- 2) het oppervlak van de prooi stimuleert een slijmproductie in de directe omgeving van de prooi, waardoor de prooi bedekt raakt met slijm. Vanaf dit moment zal dit deeltje zich gedragen als een "sticky particle".
- 3) Na een aantal happen zal het filter dreigen te verstopen. De verschillende "sticky-particles" worden nu uit de retentie-kanalen gespoeld door een omgekeerde water stroom over de zeef te voeren. Deze stroom wordt opgewekt door een zgn. gesloten protrusie beweging uit te voeren (Sibbing et al., 1986). De naar de mondholte teruggespoelde deeltjes kleven aan elkaar vast, waardoor een grote kleverige sub-bolus ontstaat. Deze sub-bolus kan zonder gevaar voor verlies naar het achterste deel

van de kieuwkamer worden getransporteerd, waar de nieuw gevormde sub-bolus vast kleeft aan de daar eventueel reeds aanwezige bolus.

- 4) Na een aantal van deze cycli zal de bolus in het achterste deel van de kieuwkamer groot genoeg zijn om te worden doorgeslikt.

De grote aantallen zoöplankton deeltjes die we per bolus hebben geteld, tot ruim 900 per bolus, wijzen erop dat de gezeefde deeltjes vrij lang in de mondholte worden opgeslagen.

Een schatting op grond van hapfrequentie, mondvolume en zoöplankton dichtheid leverde een maximale verblijftijd van ruim 3 minuten in de buccale holte. Wanneer we de slijm-productie van zoogdiercellen nemen om de productie van slijm in de brasem te schatten, zou een brasem iedere 10 seconden een hoeveelheid slijm kunnen produceren voldoende om een slijm-film met een dikte van 35 μm over de gehele kieuwkorf te leggen. Deze productie kan worden gehaald door de slijm cellen die zich op het voorste deel (75%) van de kieuwzeef bevinden. De verdeling van de slijmcellen in de zeefkanalen ondersteunen het kanalen model. Volgens dat model zouden de meeste prooien in de mediale kanalen worden gevangen. Deze mediale kanalen blijken ook een significant hoger aantal slijmcellen te bevatten, vergeleken met de laterale kanalen in hetzelfde gebied van de boog. Deze waarneming wijst erop dat hier meer of vaker slijm wordt geproduceerd. De rol die slijm bij de voedselopname van brasem blijkt te spelen is van even groot belang als het retentiemechanisme. Immers, zonder het slijm zouden de ingenieus gevangen deeltjes een gerede kans maken toch weer verloren te gaan.

Oecologische implicaties

Er zijn voor dit proefschrift een aantal facetten van de voedselopname van de brasem onderzocht, een breed spectrum van factoren heeft invloed op dit proces, zoals b.v. de grootte van de vis, de zoöplankton dichtheid en de lengte frequentie verdeling van de prooien. Het feit dat de brasem zo snel heeft kunnen profiteren van het thans overvloedige zoöplankton doet vermoeden dat hier sprake is van prae-adaptatie: waarschijnlijk gebruikte (en gebruikt) brasem tijdens het foerageren op kleine bodembewonende kreeftjes en insecten-larven ook al het hier beschreven mechanisme. Het door Lammens et al. (1987) beschreven feit dat de foerageer efficiëntie afneemt als de korrelgrootte van het substraat een zeker optimum is gepasseerd, kan een aanwijzing zijn voor het verstopt raken van de filter-kanalen en de verstoring van het retentie-mechanisme. Brasem kan een

lengte van ca. 80 cm bereiken (Maitland, 1980). Het is merkwaardig dat in een tijd van "verbraseming" slechts zelden een brasem van meer dan 50 cm wordt gevangen. Uit dit onderzoek is gebleken dat de efficiëntie van "particle-retentie" met de lengte van de vis afneemt. Brasems groter dan 50 cm kunnen waarschijnlijk geen zoöplankton meer opnemen. Vissen groter dan 50 cm zijn dan geheel op de bodemfauna aangewezen die door het grotere aantal brasems onder een verzwaarde predatiedruk staat. Dit maakt de voedsel omstandigheden voor grote brasems (> 40-50 cm S.L.) zeer ongunstig.

De vraag of brasem een superieur filtermechanisme heeft, vergeleken met dat van blankvoorn en kolblei moet nader onderzocht worden (van den Berg et al., 1991). Een dergelijke studie zou zich moeten richten op een onderzoek naar de aanwezigheid van een soortgelijk mechanisme van deeltjes retentie in het filter apparaat bij deze soorten. Het is mogelijk dat de filters verschillen in grofheid van kanalen of zelfs dat bij deze soorten het systeem van kanaaldiameter reductie ontbreekt. Indien kan worden aangetoond dat de kieuwzeef van brasem inderdaad beter werkt dan die van de coëxisterende cypriniden dan kan dat een (deel-) verklaring zijn voor het succes van brasem en de daarmee samenhangende verschuiving in de ichthyo-fauna van de nederlandse eutrofe en hypertrofe wateren.

Literatuur

- Berg, C. van den, F.A. Sibbing, J.W.M. Osse & W. Hoogenboezem, 1991. Structure, development and function of the branchial sieve of bream, Abramis brama, white bream Blicca bjoerkna and roach, Rutilus rutilus. Environ. Biol. fishes. 00: 000-000.
- Boyd, C.M., (1976). Selection of particle sizes by filter-feeding copepods: a plea for reason. Limn. & Oceanogr. 21: 175-180.
- Crowder, L.B., 1985. Optimal foraging and filter-feeding shifts in fishes. Environ. Biol. Fishes. 12: 57-62.
- Drenner, R.W., J.R. Strickler & W.J. O'Brien. 1978. Capture probability: the role of zooplankton escape in the selective feeding of zooplanktivorous fish. J. Fish. Res. Board. Can. 35: 1370-1373.
- Drost, M.R. & J.G.M. van den Boogaart 1986. A simple method for measuring the changing volume of small biological objects, illustrated by suction feeding by fish larvae and of shrinkage due to histological fixation. J. Zool. Lond. (A) 209: 239-249.
- Gibson, R.N. 1988. Development, morphometry and particle retention capability of the gill rakers in the herring, Clupea harengus L. J. Fish Biol. 32: 949-962.

- Gibson, R.N. & I.A. Ezzi, 1985. Effect of particle concentration of filter- and particulate-feeding in the herring Clupea harengus. Mar. Biol. 88: 109-116.
- Holanov, S.H. & J.C. Tash, 1978. Particulate and filter feeding in threadfin shad Dorosoma petense, at different light intensities. J. Fish. Biol. 13: 619-625.
- Jansen, J. 1976. Feeding modes and prey selection in alewife (Alosa pseudoharengus). J. Fish. Res. Board. Can. 33: 1972-1975.
- Lammens, E.H.R.R. 1984. A comparison between the feeding of white bream (Blicca bjoerkna) and bream (Abramis brama). Verh. Internat. Verein. Limnol. 22: 886-890.
- Lammens, E.H.R.R. 1985. A test of a model for planktivorous filter feeding bream Abramis brama. Env. Biol. Fish 13: 288-296.
- Lammens, E.H.R.R. 1986. Interaction between fishes and the structure of fish communities in dutch shallow, eutrophic lakes. Acad. Proefschrift, Wageningen, pp 1-100.
- Lammens, E.H.R.R., J. Geursen and P.J. MacGillavry, (1987). Diet shifts, feeding efficiency and coexistence of bream (Abramis brama, roach (Rutilus rutilus) and white bream (Blicca bjoerkna) in hypertrophic lakes. Proc. Vth Congress Europ. Ichthyol. Stockholm 1985: 153-162.
- Lazzaro, X. 1987. A review of planktivorous fishes: their evolution, feeding behaviours, selectivities and impacts. Hydrobiologia 146: 97-167.
- Maitland, P.S. 1980. Elseviers gids van de zoetwatervissen. (2e druk), Elsevier Amsterdam/Brussel.
- Rubenstein, D.L. and Koehl, M.A.R., (1977). The mechanism of filter-feeding: some theoretical considerations. Am. Nat. 11: 981-994.
- Sibbing, F.A. 1982. Pharyngeal mastication and food transport in carp (Cyprinus carpio L.): a cineradiographic and electromyographic study. J. morph. 172: 223-258.
- Sibbing, F.A., 1984. Food handling and mastication in the carp (Cyprinus carpio L.). Acad. Proefschrift, Wageningen pp 1-165.
- Sibbing F.A., 1987. The role of taste in the feeding mechanism of the carp (Cyprinidae). Ann. N.Y. Acad.Sci. 510, 612-615.
- Sibbing F.A. 1988. Specialisation and limitations in the utilization of food resources by the carp, Cyprinus carpio: a study of oral foodprocessing. Environ. Biol. Fishes. 22: 161-178.
- Sibbing F.A. 1991. Food capture and oral processing. in: Cyprinid fishes, systematics, biology and exploitation. by I.J. Winfield and J.S. Nelson (eds.) Chapman & Hall, London.
- Sibbing, F.A., J.W.M. Osse & A. Terlouw. 1986. Food handling in the carp (Cyprinus carpio L.): its movement patterns mechanism and limitations. J. Zool. Lond. 210: 161-203.
- Zander, E. 1906. Das Kiemenfilter der Teleosta. Eine morphofysiologische Studie. Z. Wiss. Zool. 619-713.

SAMENVATTING

Dit proefschrift beschrijft het mechanisme van en de selectiviteit bij de voedselopname van de brasem (Abramis brama). Het betreft een compilatie van zes artikelen over dit onderwerp. Het eerste hoofdstuk beschrijft de verschillende voedingswijzen en diëten, die bij karperachtigen zijn waargenomen. Vervolgens wordt getracht een inzicht te krijgen in de feitelijke mechanismen die aan de voedselopname ten grondslag liggen.

Röntgenfilms van op zoöplankton foeragerende brasems, met gemarkeerde kieuwbogen, toonden aan dat de spleten tussen de bogen te groot zijn voor effectieve retentie van de kleine voedseldeeltjes die brasems kunnen eten. Uit de driedimensionale bouw van het kieuwzeef apparaat werd een nieuw model afgeleid. Dit model beschrijft de retentie van kleine voedseldeeltjes in kanalen op de kieuwbogen. De kanaaldiameter kan worden gereduceerd met behulp van beweeglijke kieuwdoornen van de ernaast gelegen kieuwboog, waardoor de brasem over een instelbaar filter beschikt. De verdeling van voedseldeeltjes in de kanalen en de baan die een prooi volgt tijdens de opname ondersteunen het nieuwe model. Vergelijking van waargenomen selectiviteitscurven uit voedsel-proeven met de op grond van het kanalenmodel verwachte selectiviteit vertonen een goede overeenkomst. Uit deze curven bleek o.a. dat middelgrote (ca. 20 cm) brasems in staat zijn met ongereduceerde kanalen te filteren, terwijl dezelfde vissen in andere experimenten juist met gereduceerde kanalen fourageerden. Deze grootteklasse maakt dus gebruik van een instelbaar filter. Grote brasem (>30 cm) bleek alleen met gereduceerde kanalen te foerageren. Het zoöplankton wordt door brasem op twee manieren opgenomen a) door particulate feeding (PF), visueel gelocaliseerde prooien worden gericht deeltje voor deeltje opgenomen, en, b) d.m.v. filter-feeding (FF) waarbij ongericht een hoeveelheid water wordt gefiltreerd. De overgang van de PF naar FF hangt af van de zoöplankton dichtheid, de zwemsnelheid en het mondvolume van de vis. In dit model nemen we aan dat als het mondvolume en/of de zoöplankton dichtheid zo groot worden dat elke random hap tenminste een prooi oplevert de vis zal overgaan van PF naar FF. Daaruit volgt dat een kleine vis tot veel hogere dichtheden PF zal toepassen dan een grote vis.

Voedseldeeltjes die in de kieuwzeef zijn gevangen moeten met een zo gering mogelijk risico voor verlies naar de slokdarm worden getransporteerd. Het blijkt dat kleine prooien

voor dit transport in slijm worden verpakt. Tot 900 aan slijm gebonden prooien werden in de mondholte van een vis gevonden.

SUMMARY

This thesis describes the mechanism and the selectivity of food intake in bream (Abramis brama). It is a compilation of six articles which have been published (or will soon be published) in international journals.

In the first chapter, diets and feeding modes in cyprinid fishes are described, in order to determine the ecological position of bream within the cyprinids. The next step was to develop insight in the actual mechanism of the particle retention. X-ray movies of foraging bream, with marked gill-arches, showed too large inter-arch slits to retain small food-particles. From the 3-D architecture of the branchial sieve, a new model was derived. It assumes that particles are retained in channels on the gill-arches. The actual mesh-size of these channels can be adjusted by insertion of movable gill-rakers from the adjacent gill-arch. Distribution of retained particles in the channels and the path of ingested particles, traced with X-ray cinematography, supported the new model. Selectivity-curves, obtained from feeding-experiments, showed good correlation with curves expected from the model. It appeared that medium sized bream (ca. 20 cm) was able to feed with reduced or with unreduced channels, indicating that these fish are able to adjust its filter. Larger bream (>30 cm) foraged with reduced channels only. Two feeding modes have been observed in bream, particulate feeding (PF): in which individually located prey is attacked individually and filter-feeding (FF): an amount of water is filtered randomly. The switch from PF to FF depends on zooplankton density, swimming speed and buccal volume of the fish. It is assumed that bream switches to FF when zooplankton density and/or buccal volume becomes so large that each random snap will yield at least one prey-item. Consequently, small fish will remain particulate feeder at higher densities than larger fish. Retained particles are to be transported to the oesophagus at low risk for loss. It was found that small prey are enveloped in mucus for transport. Upto 900 zooplankters per bream have been observed in oropharyngeal mucus.

Diets and feeding behaviour

E. H. R. R. Lammens and W. Hoogenboezem

12.1 INTRODUCTION

Cyprinids comprise a wide variety of specialists and generalists feeding on all trophic levels. Detailed knowledge is available about the common European cyprinids from running and stagnant fresh water. Most feed on the secondary producers: zooplankton, macrocrustaceans, larvae, pupae and adults of insects, oligochaetes, bryozoans, snails, and mussels. Some also consume primary (macrophytes and phytoplankton) or tertiary producers (fish), but only very few use these as main food. When discussing the diets of cyprinids it is important to know both the type and availability of food organisms. Not only is their digestibility important, but more than this, how they are detected and handled by the different species (see also Chapter 13). Some are eaten by all species, but only during particular ontogenetic stages of the fish and only when the density and size of the food are sufficient. Therefore the diet must be related to the size of the fish and to availability (density, size distribution, visibility etc.) of food. This will be the main emphasis in this chapter, while the relationship with competition is described in Chapter 18. The following section gives a brief résumé of the variation in diets and habitats of the most abundant European cyprinids, together with some information regarding interspecific differences in foraging efficiency. The third and fourth sections deal with pelagic and benthic feeding modes, with emphasis on zooplankton and chironomids as food organisms and using bream, *Abramis brama*, white bream, *Blicca bjoerkna*, and roach, *Rutilus rutilus*, as model fishes. The method of feeding, differences in efficiency and the importance of the gill-raker system are described, followed by a section on switching in feeding modes and food organisms in relation to these major feeding modes. The chapter ends with a summary of major characteristics of cyprinid diets and feeding behaviours, as deduced from our studies of European species, and their likely application to other genera.

12.2 DIETS

None of the cyprinids is strictly monophagous, but many may feed on only one type of food organism, depending on availability. Some species can eat plants or plant remains, whereas others are specialized in pelagic feeding on zooplankton or fishes, and another group is more specialized in benthivorous feeding. Here we describe the diets and habitats of these three major groups. Within these groups, only the most common European cyprinids are mentioned because these are best studied: knowledge of non-European cyprinids is too fragmentary for valid comparison.

Herbivores

Rudd, *Scardinius erythrophthalmus*, roach, dace, *Leuciscus leuciscus*, and nase, *Chondrostoma nasus*, sometimes feed predominantly on macrophytes or filamentous algae (Prejs and Jackowska, 1978; Persson, 1983; Mann, 1973, 1974; Hellowell, 1971, 1972). They are, however, able to live exclusively on animal food as well, particularly zooplankton, snails and mussels (Lammens *et al.*, 1987; Ponton and Gerdeaux, 1988; Prejs, 1973, 1976; Rask, 1989; Hartley, 1947). Rudd lives almost exclusively in stagnant overgrown water, feeding on vegetation and zooplankton or on adult insects near the surface (Prejs, 1976; Hartley, 1947; Kennedy and Fitzmaurice, 1974; Johansson, 1987). Its superior mouth is suited to surface feeding, whereas its pharyngeal teeth are ideal for utilization of vegetation (Chapter 13). In contrast, the very adaptable roach occurs in both stagnant and running water and can live in open and overgrown areas. Roach feeds more efficiently on zooplankton than rudd but less efficiently than bleak *Alburnus alburnus*, bream and white bream (Johansson, 1987; Wanzenbock, 1989; Vockner and Schiemer, 1989; Lammens *et al.*, 1987; Winfield *et al.*, 1983). It is probably one of the most efficient mollusc feeders among European cyprinids (Prejs, 1976; Rask, 1989). Dace and nase occur predominantly in running waters, but also in connected lakes. They eat the same sort of food as roach, but no feeding experiments have been done with these fishes. Nase is more benthic than dace and feeds more on filamentous algae than macrophytes (Willer, 1924; Hartley, 1947). Ide, *Idus idus*, and chub, *Leuciscus cephalus*, feed also on macrophytes (Brabrand, 1985; Cala, 1970; Hellowell, 1971) but have even broader diets as they tap all trophic levels up to small fish (Boikova, 1986; Granado-Lorencio and Garcia-Novo, 1986; Willer, 1924). Both fishes prefer running water, but live very well in connected lakes, in particular in the littoral zone (Brabrand, 1985; Cala, 1970; Boikova, 1986; Hartley, 1947).

Pelagic feeders

There are a few specialized pelagic feeders, such as *Leucaspis delineatus* (Granado-Lorencio and Garcia-Novo, 1986; Boikova, 1986; Hartley, 1947).

bleak (Wanzenbock, 1989; Vollestad, 1985; Rask, 1989; Vockner and Schiemer, 1989), *Pelecus cultratus* (Herzig and Winkler, 1983; Adamicka, 1984) and the asp, *Aspius aspius* (Granado-Lorencio and Garcia-Novo, 1986; Boikova, 1986). They eat zooplankton and surface insects, and fish in the case of large *P. cultratus* and asp. *Leucaspilus* inhabits stagnant overgrown water (Willer, 1924; Hartley, 1947). The bleak lives in somewhat more open areas than *Leucaspilus* and in both stagnant and running waters (Vollestad, 1985; Vockner and Schiemer, 1989). *Pelecus* lives only in the open-water zone of stagnant and running water; this is comparable to the distribution of the asp (Herzig and Winkler, 1983; Adamicka, 1984; Boikova, 1986; Granado-Lorencio and Garcia-Novo, 1986). *Pelecus* and the asp are restricted to the eastern part of Europe.

Benthic feeders

A relatively large group is represented by the benthic feeders, such as carp, *Cyprinus carpio* (Fanget, 1972; Fitzmaurice, 1983; Moyle, 1984), barb, *Barbus barbus* (Granado-Lorencio and Garcia-Novo, 1986), gudgeon, *Gobio gobio* (Kennedy and Fitzmaurice, 1972; Willer, 1924), bream (Laskar, 1948; Kennedy and Fitzmaurice, 1968; Lammens *et al.*, 1987), tench, *Tinca tinca* (Kennedy and Fitzmaurice, 1970), white bream (Lammens, 1984; Brabrand, 1984; Rask, 1989) and crucian carp, *Carassius carassius* (Prejs, 1976; Holopainen and Hyvarinen, 1985). In particular bream, white bream, carp and barb are specialized for feeding on dipteran larvae in the sediments or organisms associated with the sediments (Laskar, 1948; Brabrand, 1984; Lammens, 1984; Tatrai, 1980; Granado-Lorencio and Garcia-Novo, 1986; Fanget, 1972; Loffler, 1984). Molluscs and seeds are often additional food for carp, tench and white bream (Kennedy and Fitzmaurice, 1970; Fitzmaurice, 1983; Crivelli, 1981; Hartley, 1947; Willer, 1924). Zooplankton is also eaten efficiently by carp (Uribe-Zamora, 1975; Sibbing, 1988), crucian carp (Prejs, 1976), and bream (Lammens *et al.*, 1987) and by the other cyprinids when they are young (Hartley, 1947). Only barb and gudgeon prefer running water (Willer, 1924; Hartley, 1947), whereas crucian carp and tench are usually restricted to overgrown areas (Prejs, 1976; Kennedy and Fitzmaurice, 1970). In this respect white bream and carp are facultative, but bream prefers the open-water zone (Hartley, 1947; Laskar, 1948; Willer, 1924).

12.3 PELAGIC FEEDING BEHAVIOUR

General aspects

Cyprinids start feeding on plankton shortly after hatching (van Densen, 1985; Jelonek, 1986; Hammer, 1985). Prey are detected visually and taken one by one. These fishes are gape limited (Zaret, 1980) and particle size is strongly

related to mouth size. With increasing size of the fish the prey choice changes, and gradually larger plankton can be swallowed (macrophagy). When the fish becomes large in relation to the plankton (microphagy), special adaptations for the retention of small organisms in the pharyngeal cavity are developed. In all groups of larger planktivorous fishes, a distinct filter apparatus has been observed (e.g. Zander, 1906). Other fishes remain macrophagous with increasing length and develop into herbivores, molluscivores, insectivores or piscivores.

Feeding modes and selectivity

Pelagic plankton is usually diverse in both species composition and size distribution. Studies on the diet of planktivorous fish showed that selectivity is more a rule than an exception (Lazarro, 1987). Food selectivity is initially determined by the feeding mode, namely particulate feeding, pump filter feeding and tow-net filter feeding (Janssen, 1976 a, b; McComas and Drenner, 1982; Gibson and Ezzi, 1985; Lammens, 1985; Chapter 13). The size of fish, mesh size of the branchial sieve, and the size, density, visibility and evasive behaviour of prey determine the selectivity of each feeding mode (Jacobs, 1978; Drenner *et al.*, 1978; Zaret and Kerfoot, 1975; Winfield *et al.* 1983; Wright and O'Brien, 1984; Hessen, 1985). The selectivity is probably also determined by the profitabilities of the different options. It is assumed that natural selection favours optimal foraging (Pyke, 1984). The switching of feeding modes (Crowder, 1985; Gibson and Ezzi, 1985; Holanov and Tash, 1978) and changing selectivity within a feeding mode (Werner and Hall, 1974; Galis and de Jong, 1988) gives some evidence for optimal foraging.

Within the cyprinids, probably all the following feeding modes are used, although most species use only one or two.

Particulate feeding

The fish detects the prey individually, approaches it and attacks it by means of fast, directed suction (for effects of these movement patterns of water and prey see Chapter 13). Janssen (1976a, 1978) distinguishes two other special forms of particulate feeding, darting and gulping.

Most small zooplanktivorous cyprinids (< 15 cm) are mainly particulate feeders. Particulate feeding, particularly darting, is a distinctly size-selective feeding mode, whereas gulping is much less size-selective because several size classes of zooplankton are sucked in simultaneously (Janssen, 1976a; Hoogenboezem, unpubl.).

Darting. The fish begins sucking when swimming towards the prey, thereby minimizing pushing water forwards and preventing evasive action. Although darting has not yet been described for cyprinids, it is likely that the active bleak and *Pelecus* use this foraging technique, because these fishes are efficient copepod feeders comparable with smelt and most percids (Ivlev, 1961;

Herzig and Winkler, 1983; Wanzenbock, 1989). Compared to percids, most cyprinids are much less selective in their first year (Densen, 1985; Bohl, 1982) and do not seem to be efficient particulate feeders. But Winfield *et al.* (1983) showed that in comparison with roach, particulate-feeding 0+ beam is more efficient at catching copepods. Probably the protrusible upper jaw of bream creates a much stronger suction force (Alexander, 1966; Osse, 1985) than in roach. Particulate-feeding cyprinids probably use a technique different from that of percids.

Gulping. This is more or less an intermediate between particulate feeding and pump filter feeding (see also Chapter 13). While the fish swims slowly it takes a series of snaps directed more or less towards local areas of higher plankton densities. These series alternate with short pauses. To enclose the maximal volume of water in each snap, the mouth protrudes distinctly during gulping (Janssen, 1976a; Sibbing, 1988). Most *Abramis*-like species and carp use this feeding mode (pers. obs.). The distinction between gulping and pump filter feeding is somewhat arbitrary, and the transition is very gradual in a gradient from light to dark.

Pump filter feeding

A slowly swimming, or stationary, fish taking a long series of suction is pump filter feeding (Uribe-Zamora, 1975; Drenner *et al.*, 1982; Holanov and Tash, 1978; Lammens, 1985). The fish is not visually orientated, but uses the very numerous taste-buds in the pharyngeal cavity (Chapter 13) to detect prey while swallowing. This feeding mode is used particularly by bream and carp in very turbid lakes and at night. Most benthivorous fish mentioned in Section 12.2 can feed in this way (Lammens *et al.*, 1987).

Tow-net filter feeding

This method involves swimming quickly with the mouth agape and opercula abducted, engulfing a cylinder of water containing the food particles (Janssen, 1976a; Rosen and Hales, 1981; Gibson and Ezzi, 1985). No records of this feeding behaviour have been published for cyprinid species, although *Alburnus alburnus* and *Pelecus cultratus* probably employ this feeding mode under favourable conditions, because they have herring-like gill raker systems. The selectivity of this strategy depends mainly on the mesh size of the branchial sieve and on the evasive abilities of the zooplankters (Janssen, 1976a; Gibson, 1988). Pump filter feeders seem to cause more water disturbance, and therefore allow more evasive zooplankters to escape, than do tow-net filter feeders (Janssen, 1976b).

Fish size and feeding modes

Most cyprinids start to feed a few days after hatching, when they have become 7–8 mm long. Rotifers, nauplii and algae are the main food types (Jelonek,

1986; Mark *et al.*, 1987). In the first weeks the fish rapidly switch to larger organisms (van Densen, 1985). In their first year, on reaching a length of *c.* 5 cm, they can eat all zooplankters, although copepods cannot be taken efficiently by all species, because of their fast escape behaviour. Bream is more efficient in feeding on copepods than roach (Winfield *et al.*, 1983). Most cyprinids can continue feeding on zooplankton until they are *c.* 15 cm long, and they can eat the large daphnids and *Leptodora* throughout life. With increasing fish size the proportions of fish and zooplankton change, in particular when the fish are no longer gape limited (> 5 cm). Then the density and size distribution of the zooplankton and the retention properties of the branchial sieve become important parameters in selection. Within one species the size selection changes in relation to fish size and food species (Lammens *et al.*, 1987). These differences can be explained by the feeding strategy, which is linked to the size of the fish and the mesh sizes of the branchial sieve (Fig. 12.1). A small fish having only a small buccal cavity is unable to process enough water to feed efficiently by means of gulping, pump filter feeding or tow-net filter feeding. For small fishes, particulate feeding is the most efficient feeding mode at natural zooplankton densities. Even at low zooplankton densities these particulate feeders forage intensively, whereas the larger filter-feeding fishes start foraging at much higher densities (Fig. 12.2).

The branchial sieve

In cyprinids the branchial sieve is composed of branchial arches with outer and inner rows of gill rakers. The form and spatial composition is species specific (Zander, 1906). The fifth arch forms the pharyngeal jaw (Sibbing, 1988). Very specialized filters with an epibranchial organ are found in silver carp, *Hypophthalmichthys molitrix* (Chapter 13). Generally the outer rakers of the first arch are longer than those on the other arches. Compared with clupeoids or coregonids, the cyprinids usually have short rakers (Zander, 1906); only *Pelecus cultratus* and *Alburnus alburnus* have comparably long rakers.

The feeding mode is closely related to the structure of this branchial sieve (Magnuson and Heitz, 1971; Matthes, 1963). Gill raker systems of bream, tench, carp, crucian carp, roach, white bream, rudd and ide are compared in Fig. 12.3. The first four fish have the highest preference for cladocerans, which is not surprising in view of the narrow spacings in their gill rakers (Table 12.1). Most studies on the branchial sieve have shown that particles smaller or larger than expected from the inter-raker distances are retained (Seghers, 1975; Kliever, 1970; Wright *et al.*, 1983). Therefore retention probably is not the simple sieving process suggested by the gaps between gill rakers (Zander, 1906; Matthes, 1963; Lammens, 1984). Hoogenboezem *et al.* (1990), using X-ray cinematography to analyse the interarch distances, showed that sieving by retention between the arches is very unlikely. In the course of one gulping movement, the distance between the arches does not

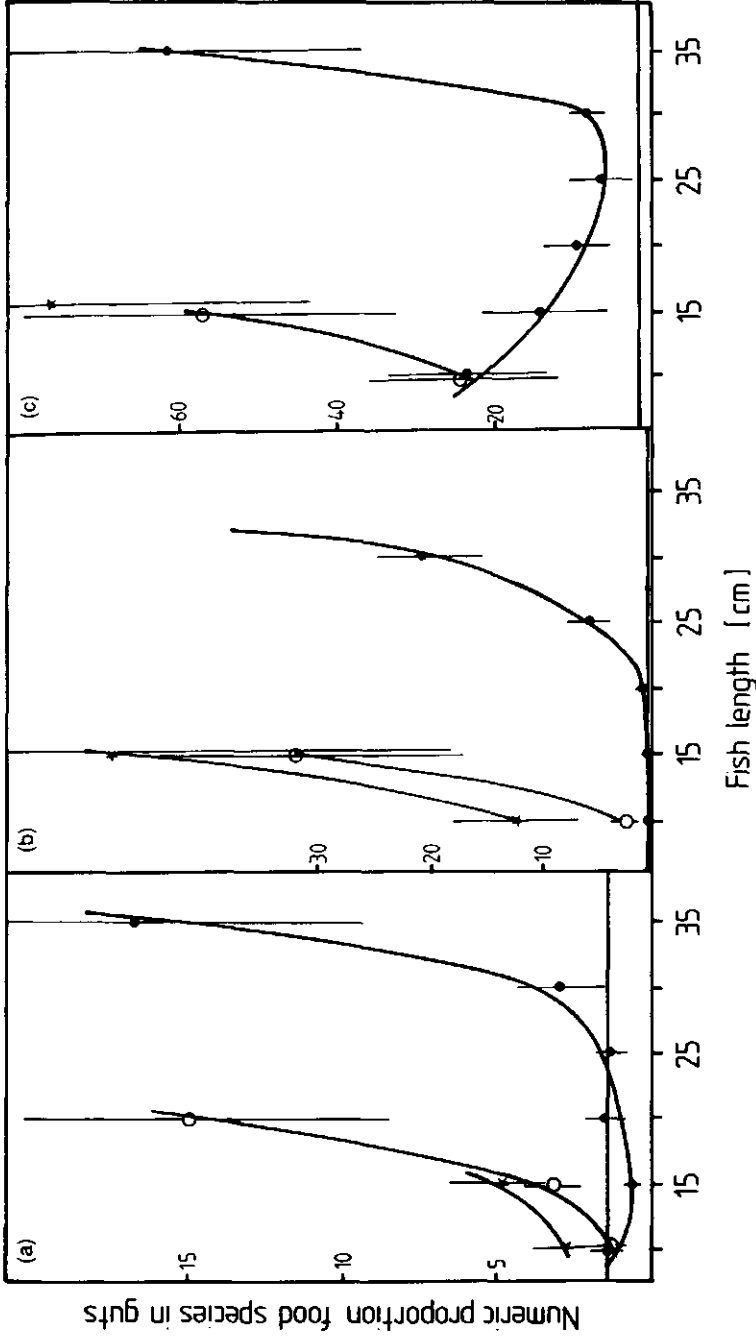

Fig. 12.1 The proportions of *Daphnia hyalina* and smaller zooplankters (a) *Bosmina coregoni*; (b) *Chydorus sphaericus*; (c) cyclopoid copepods) found in the guts of different length classes of (●) bream, (*) roach, and (○) white bream, caught simultaneously. The horizontal lines indicate the proportions of the same zooplankters in the lake. (Reproduced with permission from Lammens *et al.*, 1987).

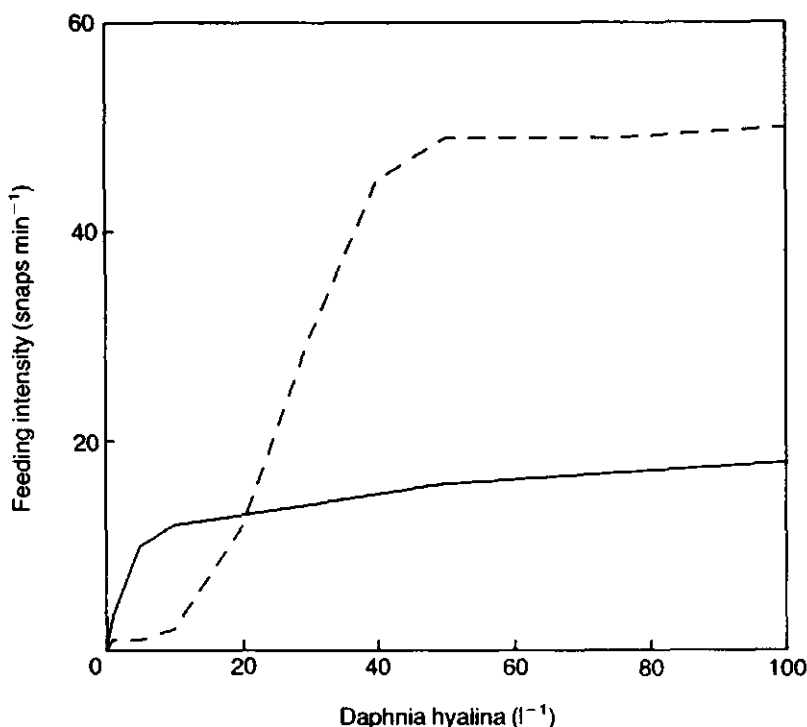

Fig. 12.2 Schematic feeding intensity of small (< 10 cm; solid curve) and large (> 30 cm; broken curve) bream in relation to density of *Daphnia hyalina*.

remain constant, and it is also different for the three successive slits (Fig. 12.4). Thus the mesh width of the branchial sieve is heterogeneous in time and place; a homogeneous filter is necessary for size-selective retention of particles (Boyd, 1976). If the branchial system of bream really acted as a sieve all the particles would disappear between the first and second arch. Apparently the mechanism of retention is not realized between the slits of the gill arches. Therefore another filter mechanism is proposed for bream.

Food particles in the branchial sieve of bream are found in the transverse channels formed between successive rakers of each gill arch. Larger cladocerans are retained in these channels; species considerably smaller than the channel diameter are probably captured by action of the movable gill rakers. Only the rakers of the outer rows are provided with muscles and fit into the transverse channels of the opposing gill arch. By lateral depression these movable rakers reduce the channel diameter when the fish is foraging on small planktonic organisms (Hoogenboezem *et al.*, 1990).

Fig. 12.3 Gill-raker systems of eight cyprinids. (a) Bream; (b) tench; (c) carp; (d) crucian carp; (e) roach; (f) white bream; (g) rudd; (h) ide. The pharyngeal teeth are visible in the lower part of the gill-raker system as modified gill arches.

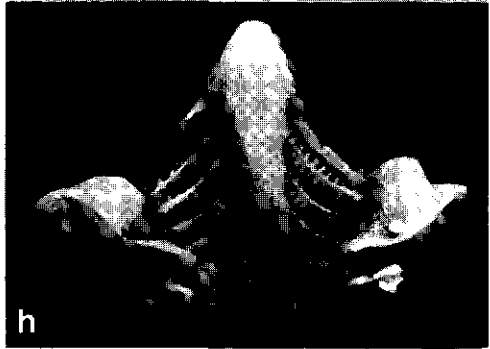
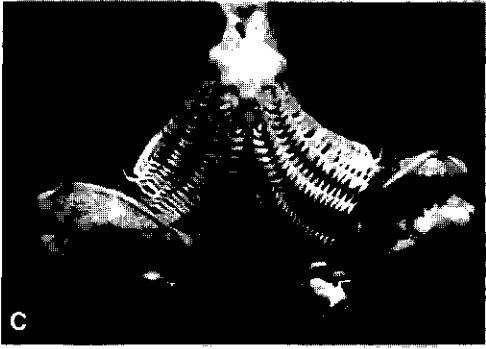
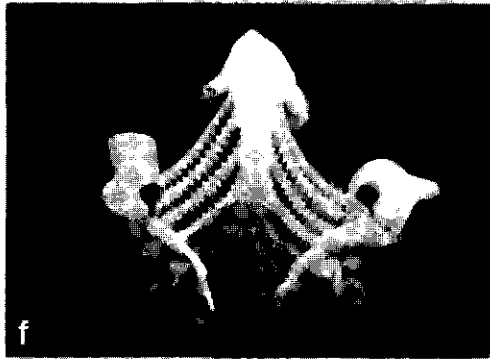
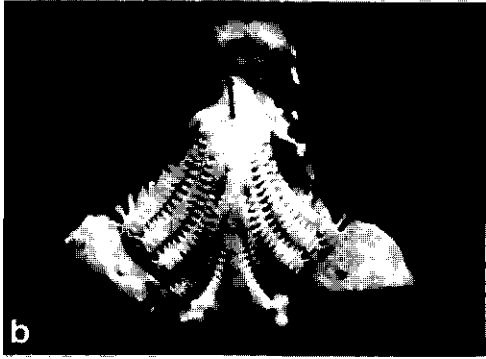
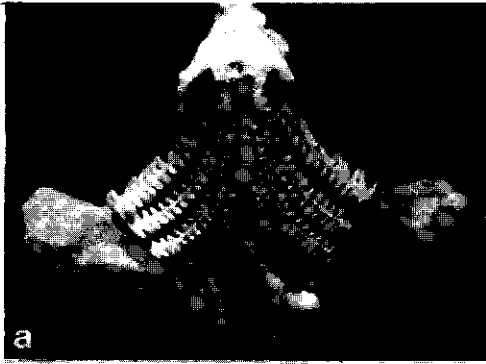

Table 12.1 Diets of the most common European cyprinids*

	Macrophytes	Detritus/ Algae	Molluscs	Macrocrust	Microcrust	Dipteran larvae	Dipteran adults	Fish
Roach <i>Rutilus rutilus</i>	**	***	***	*	*	*		*
Rudd, <i>Scardinius Erythrophthalmus</i>	***	*	+	*	*		**	
Dace, <i>Leuciscus leuciscus</i>	*	**	*	*	**	*	*	
Nase, <i>Chondrostoma nasus</i>	***	***	+	*	*	**		
Chub, <i>Leuciscus cephalus</i>	**	**	**	*	*	*	**	**
Idc, <i>Idus idus</i>	**	***	**	*	*	*	**	**
Sun bleak, <i>Leucaspis delincaus</i>					***		**	
Bleak, <i>Alburnus alburnus</i>		+			***		***	
Sabre carp, <i>Pelecus cultratus</i>				*	***		**	**
Asp, <i>Aspius aspius</i>				**	*		**	***
Bream, <i>Abramis brama</i>	+	+	+	+	**	***		*
White bream, <i>Blicca bjoerkna</i>	+	*	**	**	*	***	*	
Tench, <i>Tina tinca</i>	+	*	***	**	**	**		
Crucian carp, <i>Carassius carassius</i>	+	*	+	*	***	*		
Gudgeon, <i>Gobio gobio</i>		*	*	**	**			
Barb, <i>Barbus barbus</i>	+	*	*	**	**	***		*
Carp, <i>Cyprinus carpio</i>	*	**	**	**	**	***		

*Frequency of occurrence; +, incidental; *, regular; **, common; ***, preferred or very high.

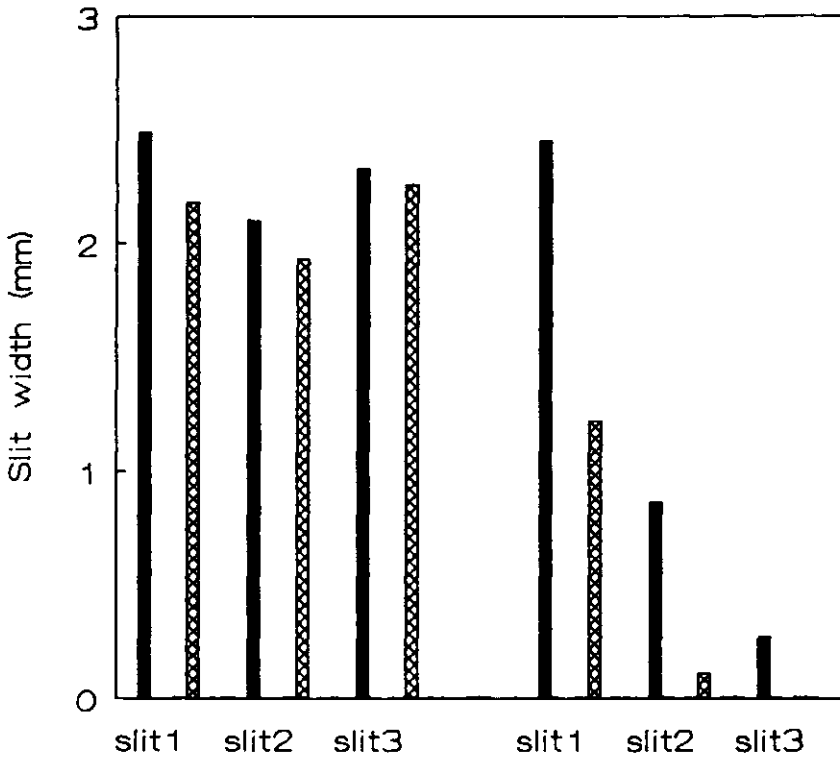

Fig. 12.4 Maximal (black columns) and minimal distances between gill arches of one bream (38.3 cm) during respiration (six columns at left) and feeding on daphnids (c. 1 mm) (five columns at right).

12.4 BENTHIC FEEDING BEHAVIOUR

General aspects

One of the most important benthic food resources are the larval chironomids, which can live in the sediment from several weeks to several months (Beattie, 1982; Winkel, 1987; Wilda, 1984; Lundbeck, 1926). Depending on size, species, and the nature of the sediment, these larvae dwell from a few millimetres to several centimetres deep in the sediments (Winkel, 1987). Therefore fish feeding on them require a specialized digging and sieving mechanism to separate them from the sediments (Matthes, 1963; Fryer, 1957; Robotham, 1982; Hyslop, 1982; Lammens *et al.*, 1987). Sibbing *et al.* (1986; see also Chapter 13) suggest that also the palatal organ plays an important role in separating food from non-food particles. All benthivorous fishes mentioned in Table 12.1 probably possess these sorting functions.

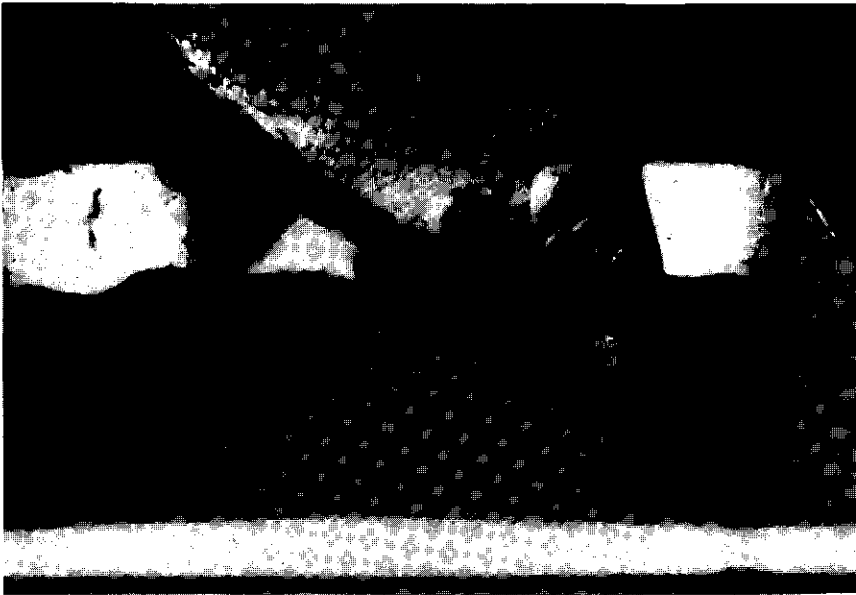

Fig. 12.5 Bream feeding on chironomids in sand substratum in a tray. Note the bottom particles, which are sucked in and expelled in clouds behind the opercula.

Cyprinids suck in the sediment particles together with the organisms and separate the organisms in the pharyngeal slit. Sediment particles pass the sieve and are visible as clouds behind the opercula (Fig. 12.5), whereas food organisms are retained. Substratum particles too large to pass the basket are spat out. Key factors determining the efficiency of feeding are the size composition of the sediment particles, the horizontal and vertical distribution of the chironomids, the density and size composition of the chironomids, the fish species and its size.

The influence of sediment characteristics

Bream, white bream and roach show similar responses to particle size of the sediments, although feeding responses are quite different (Fig. 12.6). Feeding efficiency shows an optimum which is different for species and length classes; this optimum is related to the handling time of the sand grains in the mouth cavity. Large sand grains cannot pass the gill rakers and have to be spat out, thus increasing the handling time. Small sand grains are probably eliminated through the small channels in the branchial sieve (p. 358). The size of these channels determines the maximum size of the sediment particles to pass the sieve, a relationship which differs between size classes and species. The very

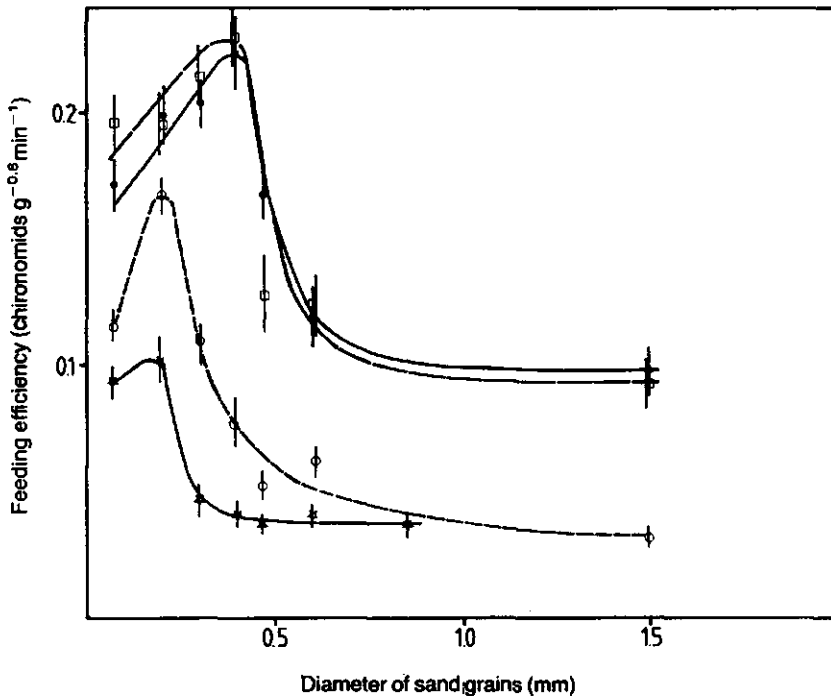

Fig. 12.6 Feeding efficiency (chironomids consumed $g^{-0.8} \text{min}^{-1}$, where $g^{-0.8}$ represents metabolic weight, indicating energy demands) in relation to the composition of the sandy substratum. ● Large bream (400–540 g); ○, small bream (50–60 g); □, white bream (160–210 g); ☆, roach (90–140 g) (reproduced with permission from Lammens *et al.*, 1987).

small particles can easily pass the gill rakers, but it probably takes more energy to take a mouthful of this sediment because of its stronger cohesiveness (at least if sediment particles are sand grains). The segregating function of the palatal organ is described in Chapter 13.

Small bream are less efficient than large bream, but also less efficient than white bream of comparable size. Mesh size of the branchial basket in small bream probably obstructs the easy passage of sediment particles. Only when chironomids are too small to be retained by large bream or white bream is the feeding efficiency of small bream higher. Roach has the lowest feeding efficiency, probably due to the poor protrusion of the upper jaw and a poorly developed branchial sieve (Fig. 12.3(e)). Feeding experiments with young roach (Diehl, 1988) also showed its low feeding efficiency compared with bream. The low preference of roach for chironomid larvae in comparison with bream and white bream further corroborates the observed differences in feeding efficiency (Adamek *et al.*, 1985; Lammens *et al.*, 1987).

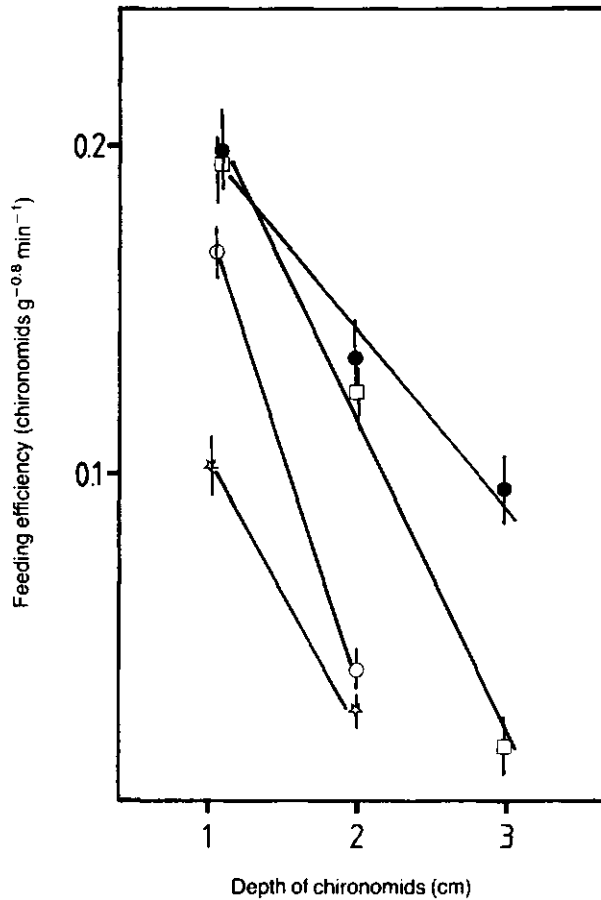

Fig. 12.7 Feeding efficiency (chironomids consumed $g^{-0.8} \text{ min}^{-1}$) in relation to the depth of the chironomids in the substratum. Symbols as in Fig. 12.6. (reproduced with permission from Lammens *et al.*, 1987).

The influence of buried, patchily distributed prey

The capture rates of small and large benthivorous fish in a fine-grained substratum are similar when the chironomids occur less than 1 cm deep; at greater depths the differences increase (Fig. 12.7). Small bream and roach almost give up foraging at 2 cm depth, but white bream at 3 cm depth (see also Brabrand, 1984). Large bream and particularly large carp can 'dig' very deep and reach the largest chironomids (Suietov, 1939). In large bream, suction force and filter mesh size are suitable for feeding most efficiently in the deepest layers. Comparisons of gut contents of white bream, bream and carp feeding on chironomids in the same environment show segregation in chironomid size

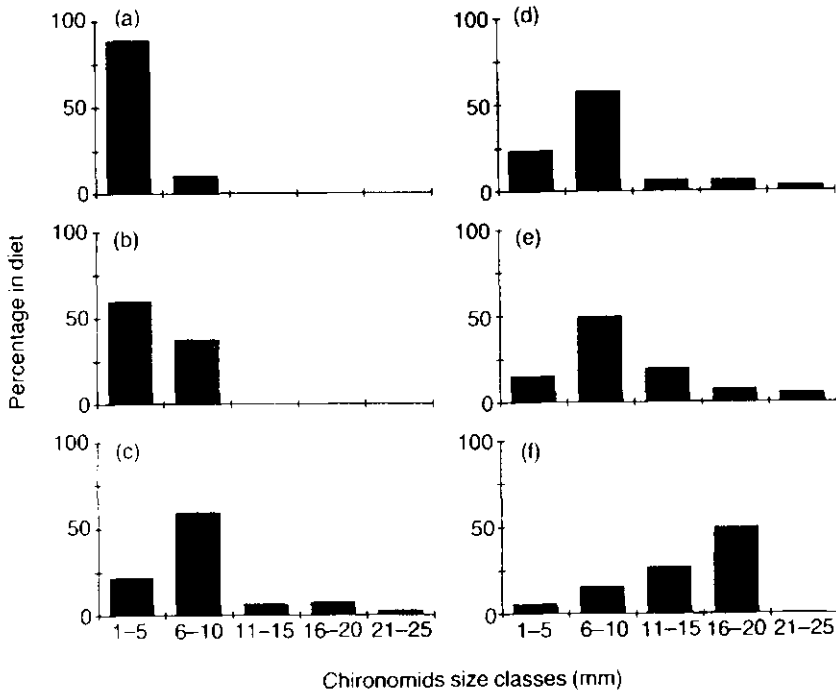

Fig. 12.8 Size composition of chironomids in the guts of different size classes of bream, white bream, and carp. The fishes were caught simultaneously (methods, Lammens, 1984). (a) 10–15 cm bream; (b) 20–25 cm bream; (c) 35–40 cm bream; (d) 10–15 cm white bream; (e) 20–25 cm white bream; (f) 50–60 cm carp.

(Fig. 12.8). Here both the retention and digging capacities are involved in feeding selectivity. Small bream (Fig. 12.8(a)) do not forage deep enough to reach the large chironomids, whereas the large carp (Fig. 12.8(f)) can hardly retain the small chironomids and have to dig deep. Large bream and white bream are intermediate in both respects. Depending on hour and time of the year, the depth of the chironomids may differ and change the feeding conditions for the different size classes and species (Winkel, 1987).

Because the chironomids are not homogeneously distributed, but are clumped vertically and horizontally (Beattie, 1982), random foraging is not efficient for the fish, which must therefore monitor the environment. There are no indications that bream, white bream, or roach can detect the chironomids other than by just taking mouthfuls (Matthes, 1963; Fryer, 1977; Robotham, 1982). Sibbing and Uribe (1985) found very high densities of taste-buds on the pharyngeal sieve and palatal organ in carp. When bream is offered sediments with varying densities of chironomids, it takes mouthfuls even in an empty substratum, and the number of chironomids per mouthful increases linearly with the density in the substratum (Fig. 12.9). So the only way for bream to

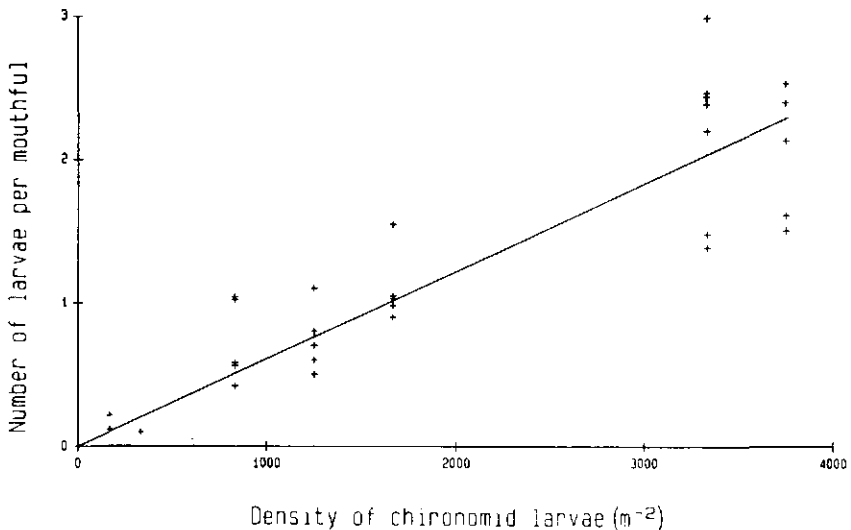

Fig. 12.9 The number of chironomids ingested per mouthful by 30–35 cm bream in relation to the density of chironomids. Each point represents the average of c. 25 mouthfuls (methods, Lammens *et al.*, 1987).

monitor the environment is taking 'samples' to know the profitability of the patches. In an unknown heterogeneous environment, bream forages in all places and intensifies foraging in the most rewarding patches: the profitability of a patch is determined by density (Fig. 12.9), substratum (Fig. 12.6), and depth of chironomids (Fig. 12.7). The fish does not, however, stop monitoring the other places. During foraging the profitability changes, and at same point the fish switches to the other patches (Fig. 12.10). In this case, at both high and low chironomid concentrations, three trays with different particle sizes were simultaneously available.

12.5 SWITCHING BETWEEN PELAGIC AND BENTHIC FEEDING

The availability of food organisms is not constant, but related to local, seasonal and diurnal changes. In particular, zooplankton and chironomids show these periodicities (Willer, 1924; Lundbeck, 1926; Beattie, 1982; Winkel, 1987; Beattie *et al.*, 1979; Gliwicz, 1967) and therefore they force the fish to adapt its feeding mode and to switch from one organism to another (Lammens *et al.*, 1985; Townsend *et al.*, 1986; Werner and Hall, 1979) in order to increase foraging profitability (Pyke, 1984). For each species and each ontogenetic stage this switch is related to the specific feeding efficiency for particular organisms. This section will discuss these switches in relation to seasonal, diurnal and local changes in food availability.

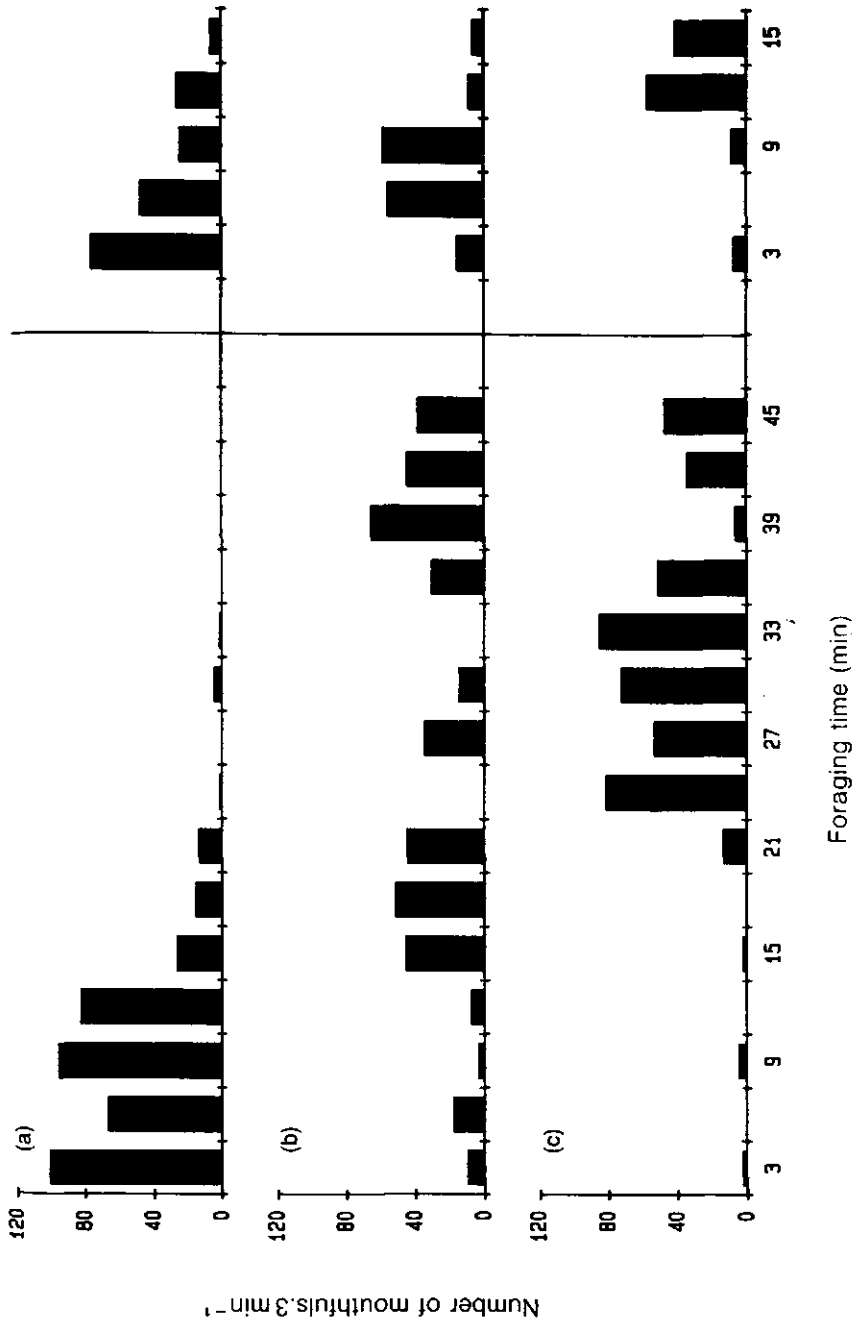

Fig. 12.10 Feeding intensity (mouthfuls per 3 min.) of 30-35 cm bream foraging on chironomids at high concentration (4000 m^{-2} , series at left) and at low concentration (1000 m^{-2} , series at right) in sediments of different particle sizes. (a) Particles 0.2-0.4 mm diameter; (b) 0.6-0.8 mm; (c) 1.7-2.4 mm. For methods see Lammens *et al.* (1987).

Switching in feeding mode and habitat

Fishes may shift their diet and feeding modes from day to day when the availability of food changes. The food resources in most natural waters vary continuously and fish have to cope with a variable environment by shifting from pelagic to benthic feeding, from particulate to filter feeding, or by migrating to other habitats.

Among food organisms, zooplankton is one of the most variable components because its availability varies seasonally and it is easily overexploited by a successful recruitment of young-of-the-year fish (Densen and Vijverberg, 1982; Cryer *et al.*, 1986; Lammens *et al.*, 1985). Zooplankton usually reaches a maximum in spring and most fishes profit from this situation to recover from spawning. In particular, fish > 20 cm take advantage of this spring peak because only in this period can they efficiently catch zooplankton by filter feeding (Lammens, 1985). Even for the smaller particulate feeders it is much more profitable to switch to filter feeding in this situation (Crowder, 1985; Gibson and Ezzi, 1985). Hoogenboezem (unpubl.) showed that small bream (c. 10 cm fork length) foraged as particulate feeders, positively selecting large (> 1 mm) cladocerans at densities < 100 l⁻¹, but started gulping at very high zooplankton densities (> 500 l⁻¹). Feeding experiments showed that bream of c. 20 cm could adjust the selectivity in relation to the availability of prey sizes (Hoogenboezem, unpubl.). When the density of zooplankton > 1 mm was high, the fish selected only them, but if it was relatively low, the fish switched to a wider range of zooplanktons > 0.5 mm length. The ability to do this points to an adjustable branchial sieve with differing energy constraints.

Although the total amount of zooplankton and chironomids hardly changes during 24 h, their availability to fishes does change because of visibility and the behaviour of the prey. In clear water, zooplankton migrate, causing periods of active feeding by bream during dusk and dawn (Kogan, 1970; Schulz and Berg, 1987) or only at night (Bohl, 1980). The fish may respond not only to prey, but to predators as well. The feeding periodicity in turbid lakes is quite different for young fish because as particulate feeders they have enough light only during daytime (Diehl, 1988). Some of them may switch to filter feeding during the night (Holanov and Tash, 1978; Gibson and Ezzi, 1985). In Tjeukemeer, only bream > 20 cm continue feeding on zooplankton at night and show the lowest feeding intensity during the day. Similar bream hardly feed during the night (Lammens, 1983). Similarly, feeding on chironomid larvae is maximal at night, because no light is needed (see also Diehl, 1988) and probably because chironomids are then higher in the sediments in response to changing oxygen tensions.

When the zooplankton density or size distribution drops below some level, only the smaller length classes of fish continue particulate feeding, but larger fishes switch to a more profitable food source. For roach and all the herbivores in Table 12.1, vegetation or molluscs and even detritus will be an alternative.

The benthivores will switch to chironomids, *Tubifex* or benthic cladocerans. With increasing food depletion detritus becomes a very large part of the diet (Chapter 19). Roach seems to utilize detritus relatively well because of its special enzyme system (Prejs, 1977), although it is unknown whether other species can do this. The more specialized pelagic feeders such as bleak and *Pelecus* will only switch from zooplankton in extreme conditions such as in periods when insects pupate and come to the surface.

12.6 CONCLUDING REMARKS AND IMPLICATIONS FOR NON-EUROPEAN CYPRINIDS

European cyprinids show a wide variety of diets and feeding modes and have specialized representatives as zooplanktivores, herbivores, piscivores and benthivores. Most European cyprinids are zooplanktivores from the larval period up to a length of 5–10 cm. Only a few species are specialized as zooplanktivores during a large part of their lives. Some species can live as herbivores, others as benthivores. Several, however, such as roach, white bream, bream and carp can feed in different modes and switch easily between these modes. While the roach is considered one of the most successful generalists, most cyprinids use more than one feeding mode and can feed on both pelagic and benthic prey. The branchio-spinal system is well developed and has an important function in feeding on relatively small organisms, which are filtered from the water or sieved from the substratum. The fifth gill arch, modified into pharyngeal teeth, is crucial in mollusc feeding and herbivory. The feeding mode employed ranges from strict particulate feeding to strict filter feeding, and this gradient in feeding modes is found both in pelagic and in benthic feeders.

From our studies on cyprinids and an extensive literature review, we conclude that the feeding of European cyprinids includes all diets and feeding modes and probably does not differ essentially from cyprinid feeding on the other continents. The feeding modes are not exclusive to cyprinids, as many of them are also found in clupeids (Janssen, 1976a; Holanov and Tash, 1978; Drenner *et al.*, 1982; Gibson and Ezzi, 1985), cichlids (Fryer and Iles, 1972; Galis and de Jong, 1988), and coregonids (Ponton and Gerdeaux, 1988; Svardson, 1979; Bergstrand, 1982). The cyprinids from Asia seem to have the greatest variety in feeding specialists with both small and large species (Grzimek *et al.*, 1970), whereas the cyprinids in North America have the smallest variety apart from South America and Australia, where cyprinids are poorly represented and are mainly small species (Grzimek *et al.*, 1970). Cyprinids in Africa are also relatively small, but more varied in feeding specialists (Matthes, 1963). These are evolutionary aspects and a good comparison between the continents would be very fruitful for a better understanding of the variety of the cyprinids.

ACKNOWLEDGEMENTS

We want to thank Ramesh Gulati, Ferdinand Sibbing, Onno van Tongeren, Koos Vijverberg and an anonymous reviewer for their critical comments on the manuscript.

REFERENCES

- Adamek, Z., Jirasek, J., Pravda, D., Sukop, I., Hetesa, J., Provazek, R. and Skrabanek, A. (1985) The food biology and biological value of roach (*Rutilus rutilus* L.) in the Musovska reservoir. *Zivoc. Vyr. (Sb. čsl. Akad. zeměd. Věd., Rada E)*, **30**, 901–10.
- Adamicka, P. (1984) On the construction of the Pontic cyprinid *Pelecus cultratus* (L.). *Arch. Hydrobiol.*, **101**, 9–19.
- Alexander, R. Mc. N. (1966) The functions and mechanisms of the protrusible upper jaws in two species of cyprinid fish. *J. Zool., Lond.*, **149**, 288–96.
- Beattie, D. M. (1982) Distribution and larval production of chironomid populations in Tjeukemeer. *Hydrobiologia*, **95**, 287–306.
- Beattie, D. M., Golterman, H. L. and Vijverberg, J. (1979) An introduction to the limnology of the Friesian lakes. *Hydrobiologia*, **58**, 49–64.
- Bergstrand, E. (1982) The diet of four sympatric whitefish species in Lake Parkijaure. *Rep. Inst. Freshwat. Res. Drottningholm*, **60**, 5–14.
- Bohl, E. (1980) Diel pattern of pelagic distribution and feeding in planktivorous fish. *Oecologia*, **44**, 368–75.
- Bohl, E. (1982) Food supply and prey selection in planktivorous cyprinidae. *Oecologia*, **53**, 134–8.
- Boikova, O. S. (1986) Feeding of fish in Lake Glubokoe. *Hydrobiologia*, **141**, 95–111.
- Boyd, C. M. (1976) Selection of particle sizes by filter-feeding copepods: a plea for reason. *Limnol. Oceanogr.*, **21**, 175–80.
- Brabrand, A. (1984) Microhabitat segregation between bream (*Abramis brama* (L.)) and white beam (*Blicca bjoerkna* (L.)) in a mesotrophic lake, SE Norway. *Pol. Arch. Hydrobiol.*, **31**, 99–108.
- Brabrand, A. (1985) Food of roach (*Rutilus rutilus*) and ide (*Leuciscus idus*): significance of diet shift for interspecific competition in omnivorous fishes. *Oecologia*, **66**, 461–7.
- Cala, P. (1970) On the ecology of the ide *Idus idus* L. in the river Kavlingeån, south Sweden. *Rep. Inst. Freshwat. Res. Drottningholm*, **50**, 45–99.
- Crivelli, A. J. (1981) The biology of the common carp, *Cyprinus carpio* L. in the Camargue, southern France. *J. Fish Biol.*, **18**, 271–90.
- Crowder, L. B. (1985) Optimal foraging and feeding mode shifts in fishes. *Environ. Biol. Fishes*, **12**, 57–62.
- Cryer, M., Peirson, G. and Townsend, C. R. (1986) Reciprocal interactions between roach, *Rutilus rutilus*, and zooplankton in a small lake: prey dynamics and fish growth and recruitment. *Limnol. Oceanogr.*, **31**, 1022–38.
- Densen, W. L. T. van (1985) Feeding behaviour of major 0+ fish species in a shallow, eutrophic lake (Tjeukemeer, The Netherlands). *Z. angew. Ichtyol.*, **2**, 49–70.
- Densen, W. L. T. van and Vijverberg, J. (1982) The relations between 0+ fish density, zooplankton size and the vulnerability of pikeperch, *Stizostedion lucioperca*, to angling in the Friesian lakes. *Hydrobiologia*, **95**, 321–36.
- Diehl, S. (1988) Foraging efficiency of three freshwater fishes: effects of structural complexity and light. *Oikos*, **53**, 207–14.

- Drenner, R. W., O'Brien, W. J. and Mummert, J. R. (1982) Filter-feeding rates of gizzard shad. *Trans. Am. Fish. Soc.*, **111**, 210–15.
- Drenner, R. W., Strickler, J. R. and O'Brien, W. J. (1978) Capture probability: the role of zooplankton escape in the selective feeding of planktivorous fish. *J. Fish. Res. Bd Can.*, **35**, 1370–73.
- Fanget, R. (1972) Contribution à l'écologie des étangs piscicoles de la Dombes: sur le régime alimentaire de la carpe à miroir (*Cyprinus carpio* L.), doctoral thesis, University of Lyon.
- Fitzmaurice, P. (1983) Carp (*Cyprinus carpio* L.) in Ireland. *Irish Fish. Invest.*, Ser. A., **23**, 5–10.
- Fryer, G. (1957) The trophic interrelationships and ecology of some littoral communities of Lake Nyasa with especial reference to the fishes, and a discussion of the evolution of a group of rock-frequenting cichlidae. *Proc. Zool. Soc. Lond.*, **130**, 11–279.
- Fryer, G. and Iles, T. D. (1972) *Cichlid Fishes of the Great Lakes of Africa*. Oliver and Boyd, Edinburgh.
- Galis, F. and Jong, P. W. de (1988) Optimal foraging and ontogeny: food selection by *Haplochromis piceatus*. *Oecologia*, **75**, 175–84.
- Gibson, R. N. (1988) Development, morphometry and particle retention capability of the gill rakers in the herring, *Clupea harengus* L. *J. Fish Biol.*, **32**, 949–62.
- Gibson, R. N. and Ezzi, I. A. (1985) Effect of particle concentration of filter- and particular-feeding in the herring *Clupea harengus*. *Mar. Biol.*, **88**, 109–16.
- Gliwicz, Z. M. (1967) Zooplankton and temperature–oxygen condition of two alpine lakes of Tatra Mts. *Pol. Arch. Hydrobiol.*, **14**, 53–72.
- Grando-Lorencio, C. and Gracia–Novo, F. (1986) Feeding habits of the fish community in a eutrophic reservoir in Spain. *Ekol. pol.*, **34**, 95–110.
- Grzimek, B., Ladiges, W., Portman, A. and Thenius, E. (1970) *Grzimek Tierleben. Fische I. Enzyklopedie des Tierreiches*, Kündler Verlag, Zurich.
- Hammer, C. (1985) Feeding behaviour of roach (*Rutilus rutilus*) larvae and the fry of perch (*Perca fluviatilis*) in Lake Lankau. *Arch. Hydrobiol.*, **103**, 61–74.
- Hartley, P. H. T. (1947) The natural history of some British freshwater fishes. *Proc. zool. Soc. Lond.*, **117**, 129–206.
- Hellawell, J. M. (1971) The autecology of the club, *Squalius cephalus* L. of the river Lugg and Afon Llynfi. III. Diet and feeding habits. *Freshwat. Biol.*, **1**, 369–87.
- Hellawell, J. M. (1972) The growth, reproduction and food of the roach *Rutilus rutilus* L. of the river Lugg, Herefordshire. *J. Fish Biol.*, **4**, 469–86.
- Herzig, A. and Winkler, H. (1983) Beiträge zur Biologie des Sichelings, *Pelecus cultratus* L. *Öst. Fisch.*, **36**, 113–28.
- Hessen, D. O. (1985) Selective zooplankton predation by pre-adult roach (*Rutilus rutilus*): the size-selective hypothesis versus the visibility-selective hypothesis. *Hydrobiologia*, **124**, 73–9.
- Holanov, S. H. and Tash, J. C. (1978) Particulate and filter feeding in threadfin shad, *Dorosoma petenense*, at different light intensities. *J. Fish. Biol.*, **13**, 619–25.
- Holopainen, I. J. and Hyvarinen, H. (1985) Ecology and physiology of crucian carp (*Carassius carassius* (L.)) in small Finnish ponds with anoxic conditions in winter. *Verh. Internat. Verein. Limnol.*, **22**, 2566–70.
- Hoo genboezem, W., Sibbing, F. A., Osse, J. W. M., Boogaart, J. G. M. van den, Lammens, E. H. R. R. and Terlouw, A. (1990) Measuring gill-arch movements in filter-feeding bream (*Abramis brama*, Cyprinidae). *J. Fish Biol.*, **36**, 47–59.
- Hyslop, E. J. (1982) The feeding habits of 0+ stone loach, *Noemacheilus barbatulus* (L.), and bullhead, *Cottus gobio* L. *J. Fish. Biol.*, **21**, 187–96.
- Ivlev, V. S. (1961) *Experimental Ecology of the Feeding of Fishes*, Yale Univ. Press, New Haven, 302 pp.

- Jacobs, J. (1978) Influence of prey size, light intensity, and alternative prey on the selectivity of plankton feeding fish. *Verh. Internat. Verein. Limnol.*, **20**, 2461-6.
- Janssen, J. (1976a) Feeding modes and prey size selection in the alewife (*Alosa pseudoharengus*). *J. Fish. Res. Bd Can.*, **33**, 1972-5.
- Janssen, J. (1976b) Selectivity of an artificial filter feeder and suction feeders on calanoid copepods. *Am. Midl. Nat.*, **95**, 491-3.
- Janssen, J. (1978) Feeding-behavior repertoire of the alewife, *Alosa pseudoharengus*, and the ciscoes *Coregonus hoyi* and *C. artedii*. *J. Fish. Res. Bd. Can.*, **35**, 249-53.
- Jelonek, M. (1986) Food of juvenile stages of rudd (*Scardinius erythrophthalmus* L.), roach (*Rutilus rutilus* L.), and perch (*Perca fluviatilis* L.) in the heated waters of the Rybnik dam reservoir (Southern Poland). *Acta hydrobiol., Kraków*, **28**, 451-61.
- Johansson, L. (1987) Experimental evidence for interactive habitat segregation between roach (*Rutilus rutilus*) and rudd (*Scardinius erythrophthalmus*) in a shallow eutrophic lake. *Oecologia*, **73**, 21-7.
- Kennedy, M. and Fitzmaurice, P. (1968) The biology of the bream, *Abramis brama* L. in Irish waters. *Proc. R. Ir. Acad.*, **B**, **67**(5), 95-157.
- Kennedy, M. and Fitzmaurice, P. (1970) The biology of the tench, *Tinca tinca* L. in Irish waters. *Proc. R. Ir. Acad.*, **B**, **69**(3), 31-82.
- Kennedy, M. and Fitzmaurice, P. (1972) Some aspects of the biology of the gudgeon *Gobio gobio* L. in Irish waters. *J. Fish Biol.*, **4**, 425-40.
- Kennedy, M. and Fitzmaurice, P. (1974) The biology of the rudd, *Scardinius erythrophthalmus* L. in Irish waters. *Proc. R. Ir. Acad.*, **B**, **74**, 245-305.
- Kliwer, E. V. (1970) Gill-raker variation and the diet in lake whitefish *Coregonus clupeaformis* in Northern Manitoba, in *Biology of Coregonid Fishes* (eds C. C. Lindsey and C. S. Woods). Univ. of Manitoba Press, Winnipeg pp. 147-65.
- Kogan, A. V. (1970) Age-related and seasonal changes in the daily feeding rhythm of the Tsimlyansk Reservoir bream. *J. Ichthyol.*, **10**, 557-61.
- Lammens, E. H. R. R. (1983) *Progress report 1981*. Limnological Institute of the Royal Netherlands Academy of Arts and Sciences, pp. 58-9.
- Lammens, E. H. R. R. (1984) A comparison between the feeding of white bream (*Blicca bjoerkna*) and bream (*Abramis brama*). *Verh. Internat. Verein. Limnol.*, **22**, 886-90.
- Lammens, E. H. R. R. (1985) A test of a model for planktivorous filter feeding by bream *Abramis brama*. *Environ. Biol. Fishes*, **13**, 288-96.
- Lammens, E. H. R. R., Geursen, J. and MacGillavry, P. J. (1987) Diet shifts, feeding efficiency and coexistence of bream *Abramis brama*, roach *Rutilus rutilus* and white bream *Blicca boerkna* in hypertrophic lakes. *Prov. V. Cong. Eur. Ichthyol.*, 153-62.
- Lammens, E. H. R. R., Nie, H. W. de, Vijverberg, J. and Densen, W. I. T. van (1985) Resource partitioning and niche shifts of bream (*Abramis brama*) and eel (*Anguilla anguilla*) mediated by predation of smelt (*Osmerus eperlanus*) on *Daphnia hyalina*. *Can. J. Fish. aquat. Sci.*, **42**, 1342-51.
- Laskar, K. (1948) Ernährung des Brassens in eutrophen Seen. *Arch. Hydrobiol.*, **42**, 1-165.
- Lazzaro, X. (1987) A review of planktivorous fishes: their evolution, feeding behaviours, selectivities, and impacts. *Hydrobiologia*, **146**, 97-167.
- Löffler, H. (1984) Zur Ökologie des Brachsen (*Abramis brama* (L.)) im Bodensee. *Schweiz. Z. Hydrol.*, **46**, 147-62.
- Lundbeck, J. (1926) Die Bodentierwelt norddeutscher Seen. *Arch. Hydrobiol.*, Suppl. **7**, 1-473.
- McComas, S. R. and Drenner, R. W. (1982) Species replacement in a reservoir fish community: silverside feeding mechanics and competition. *Can. J. Fish. aquat. Sci.*, **39**, 815-21.
- Magnuson, J. J. and Heitz, J. G. (1971) Gill raker apparatus and food selectivity among mackerels, tunas, and dolphins. *Fish. Bull. Nat. Mar. Fish. Serv.*, **69**, 361-70.

- Mann, R. H. K. (1973) Observations on the age, growth, reproduction and food of the roach *Rutilus rutilus* L. in two rivers in Southern England. *J. Fish Biol.*, **5**, 707-36.
- Mann, R. H. K. (1974) Observations on the age, growth, reproduction and food of the dace *Leuciscus leuciscus* L. in two rivers in Southern England. *J. Fish Biol.*, **6**, 237-53.
- Mark, W., Hofer, R. and Wieser, W. (1987) Diet spectra and resource partitioning in the larvae and juveniles of three species and six cohorts of cyprinids from a subalpine lake. *Oecologia*, **71**, 388-96.
- Matthes, H. (1963) A comparative study of the feeding mechanism of some African Cyprinidae (Pisces, Cypriniformes). *Bijdr. Dierk.*, **33**, 1-35.
- Moyle, P. B. (1984) America's carp. *Nat. Hist. N.Y.*, **84**(9), 43-50.
- Osse, J. W. M. (1985) Jaw protrusion, an optimization of the feeding apparatus of teleosts?. *Acta Biotheor.*, **34**, 219-32.
- Persson, L. (1983) Food consumption and the significance of detritus and algae to intraspecific competition in roach *Rutilus rutilus* in a shallow eutrophic lake. *Oikos*, **41**, 118-25.
- Ponton, D. and Gerdeaux, D. (1988) Quelques aspects de l'alimentation de deux poissons planctonophages du lac leman: le corégone (*Coregonus schinzii palea* Cuv. et Val.) et le gardon (*Rutilus rutilus* (L.)) *Bull. fr. pêche Piscic.*, **308**, 11-23.
- Prejs, A. (1973) Feeding of introduced and aurochthonous non-predatory fish, in *Experimentally Increased Fish Stock in the Pond Type Lake Warniak* (ed. E. Pieczynski) *Ekol. pol.*, **21**, 464-505.
- Prejs, A. (1976) Fishes and their feeding habits, in *Selected Problems in Lake Littoral Ecology* (ed. E. Pieczynski), Warsaw Univ. Press, Warsaw, pp. 155-71.
- Prejs, A. (1977) Relationships between food and cellulase activity in freshwater fishes. *J. Fish Biol.*, **11**, 447-52.
- Prejs, A. and Jackowska, H. (1978) Lake macrophytes as the food for roach (*Rutilus rutilus*) and rudd (*Scardinius erythrophthalmus*) I. Species composition and dominance relations in the lake and food. *Ekol. pol.*, **26**, 429-38.
- Pyke, G. H. (1984) Optimal foraging theory: a critical review. *A. Rev. Ecol. Syst.*, **15**, 523-75.
- Rask, M. (1989) The diet of roach and some other cyprinids in the northern Baltic sea. *Aqua Fenn.*, **19**, 19-27.
- Robotham, P. W. J. (1982) An analysis of a specialized feeding mechanism of the spined loach, *Cobitis taenia* (L.), and a description of the related structures. *J. Fish. Biol.*, **20**, 173-81.
- Rosen, R. A. and Hales, D. C. (1981) Feeding of paddlefish, *Polyodon spathula*. *Copeia*, **2**, 441-55.
- Schulz, U. and Berg, R. (1987) The migration of ultrasonic-tagged bream, *Abramis brama* (L.) in Lake Constance (Bodensee-Untersee). *J. Fish Biol.*, **31**, 409-14.
- Seghers, B. H. (1975) Role of gill-rakers in the size-selective predation by lake whitefish, *Coregonus clupeaformis* (Mitchill). *Verh. Internat. Verein. Limnol.*, **19**, 2401-5.
- Sibbing, F. A. (1988) Specializations and limitations in the utilization of food resources by the carp, *Cyprinus carpio*: a study of oral food processing. *Environ. Biol. Fishes*, **22**, 161-78.
- Sibbing, F. A. and Uribe, R. (1985) Regional specializations in the oro-pharyngeal wall and food processing in the carp (*Cyprinus carpio* L.). *Neth. J. Zool.*, **35**, 377-422.
- Sibbing, F. A., Osse, J. W. M. and Terlouw, A. (1986) Food handling in the carp (*Cyprinus carpio*): its movement patterns, mechanisms and limitations. *J. Zool., Lond.*, **210**, 161-203.
- Suietov, S. V. (1939) A contribution to the knowledge of fish productivity in water bodies. Communication 8. The role of silt mass in the use of natural food by fish. (In Russian). *Trudy limnol. Sta. Kosine*, **22**, 241-9.

- Svardson, G. (1979) Speciation of Scandinavian *Coregonus*. *Rep. Inst. Freshwat. Res., Drottningholm*, **57**, 1-95.
- Tatrai, I. (1980) About feeding conditions of bream, (*Abramis brama* L.) in Lake Balaton. *Hydrobiologia*, **3**, 81-6.
- Townsend, C. R., Winfield, I. J., Peirson, G. and Cryer, M. (1986) The response of young roach *Rutilus rutilus* to seasonal changes in abundance of microcrustacean prey: a field demonstration of switching. *Oikos*, **46**, 372-8.
- Uribe-Zamora, M. (1975) Selection des proies par le filtre branchial de la carpe miroir, *Cyprinus carpio* L., thesis, Lyon (127 pp.)
- Vockner, F. H. W. and Schiemer, F. (1990) Spatial distribution and feeding ecology of bleak (*Alburnus alburnus* L.) and roach (*Rutilus rutilus* L.) in an eutrophic lake (Wallersee, Austria). *Holarctic Ecol.* (in press).
- Vollestad, L. A. (1985) Resource partitioning of roach *Rutilus rutilus* and bleak *Alburnus alburnus* in two eutrophic lakes in SE Norway. *Holarctic Ecol.* **8**, 88-92.
- Wanzenböck, J. (1989) Prey detection in cyprinids during early development. *Can. J. Fish. aquat. Sci.*, **46**, 995-1001.
- Werner, E. E. and Hall, D. J. (1974) Optimal foraging and the size selection of prey by the bluegill sunfish (*Lepomis macrochirus*). *Ecology*, **55**, 1042-52.
- Werner, E. E. and Hall, D. J. (1979) Foraging efficiency and habitat switching in competing sunfishes. *Ecology*, **60**, 256-64.
- Wilda, T. J. (1984) The production of genera of chironomidae (Diptera) in lake Norman, a North Carolina reservoir. *Hydrobiologia*, **108**, 145-52.
- Willer, A. (1924) *Die Nahrungstiere der Fische*. Handbuch der Binnenfischerei Mitteleuropas I, Schweizerbart'sche, Stuttgart, 1-145.
- Winfield, I. J., Peirson, G., Cryer, M. and Townsend, C. R. (1983) The behavioural basis of prey selection by underyearling bream (*Abramis brama* (L.)) and roach (*Rutilus rutilus* (L.)). *Freshwat. Biol.* **13**, 139-49.
- Winkel, E. H. ten (1987) Chironomid larvae and their foodweb relations in the littoral zone of lake Maarseveen, PhD thesis, University of Amsterdam. (145 pp.)
- Wright, D. I. and O'Brien, W. J. (1984) The development and field test of a tactical model of the planktivorous feeding of white crappie (*Pomoxis annularis*). *Ecol. Monogr.* **54**, 65-98.
- Wright, D. I., O'Brien, W. J. and Luecke, C. (1983) A new estimate of zooplankton retention by gill rakers and its ecological significance. *Trans. Am. Fish. Soc.*, **112**, 638-46.
- Zander, E. (1906) Das Kiemenfilter der Teleosta. Eine morphophysiologische Studie. *Z. wiss. Zool.*, **84**, 619-713.
- Zaret, T. M. (1980) *Predation and Freshwater Communities*, Yale Univ. Press, New Haven, 187 pp.
- Zaret, T. M. and Kerfoot, W. C. (1975) Fish predation on *Bosmina longirostris*, body-size selection versus visibility selection. *Ecology*, **56**, 232-7.

X-ray measurements of gill-arch movements in filter-feeding bream, *Abramis brama* (Cyprinidae)

W. HOOGENBOEZEM*†, F. A. SIBBING*, J. W. M. OSSE*,
J. G. M. V.D. BOOGAART*, E. H. R. R. LAMMENS† AND A. TERLOUW*

*Department of Experimental Animal Morphology and Cell Biology,
Agricultural University, Marijkeweg 40, 6709 PG Wageningen, The Netherlands and
†Limnological Institute, Tjeukemeer Laboratory, de Akkers 47, 8536 VD Oosterzee,
The Netherlands

(Received 10 February 1989, Accepted 3 July 1989)

The technique of X-ray cinematography was used to study pharyngeal movements in *Abramis brama* (L.). The theoretical and practical problems in X-ray cinematography of feeding fish are discussed, as well as criteria for the selection of images suited for detailed measurements.

Respiration and filter-feeding on *Daphnia pulex* (length c. 1 mm) show different gill arch movement patterns in bream. Slits between gill-arches are kept smaller during filter-feeding. In addition, during filter-feeding, this inter-arch distance decreases considerably in a posterior direction. The hypothesis that particle retention occurs on the slits formed between adjacent gill-arches and their gill-rakers is not supported by the present results.

Key words: *Abramis brama*; filter-feeding; gill slits; feeding mechanism; branchial sieve.

I. INTRODUCTION

The fish fauna of Dutch eutrophic lakes is increasingly dominated by bream, *Abramis brama* (L.), (Lammens, 1986). Bream appear to have a greater chance of survival than other sympatric cyprinid species [*Blicca björkna* (L.) and *Rutilus rutilus* (L.)]. This may result from a more efficient utilization of the available food resources, zooplankton and chironomid larvae, combined with improved avoidance of predation. As the bream is a very efficient filter-feeder on zooplankton (Lammens *et al.*, 1987), we have investigated its filtering mechanism by studying the structure and functioning of the branchial sieve, the site of food retention. According to long-standing hypotheses (e.g. Zander, 1906; Matthes, 1963; Lammens, 1984), internal size selection of food particles is achieved by the inter-digitation of gill rakers between adjacent gill arches. Therefore, a method was developed to measure the supposed movement of the gill arches. During respiration and filter-feeding we expect different movement patterns. Gill slits during filter-feeding should be small enough to retain food particles, whereas such narrow slits would increase flow resistance during respiration. Thus, gill slits, measured from net inter-arch distances, and the size of zooplankters are the main parameters used to test the present particle retention hypothesis.

Application of X-ray cinematography to the functional analysis of feeding actions of fish (Sibbing, 1982, 1988; Liem, 1986) enabled the study of movement patterns inside the fish. Prior to analysing the filtration mechanism in bream, it was necessary to test the resolving power and accuracy of this technique by measuring

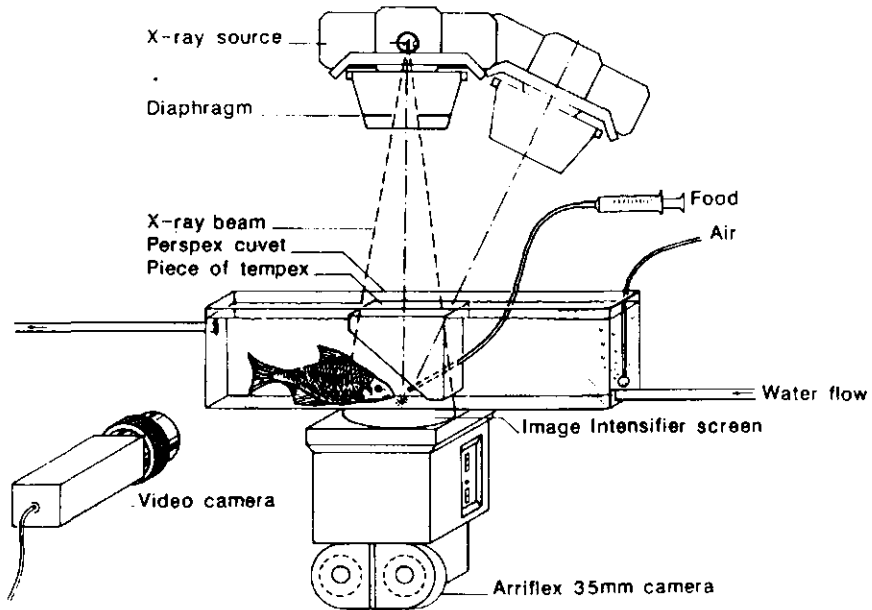

FIG. 1. Experimental set-up (see text).

gill arch movements in active fish. Since X-ray cinematography is a relatively unknown technique in fish biology, some technical aspects are given in detail.

II. MATERIALS AND METHODS

FISH

Bream between 25 and 40 cm fork length (F.L.) were captured in Tjeukemeer, a shallow eutrophic lake in the northern part of the Netherlands. They were kept at the laboratory in tanks of well aerated water at 15° C, and were fed on frozen chironomid larvae and zooplankton of different size classes, obtained from the lake.

EXPERIMENTAL SET-UP AND TRAINING

The X-ray cine recordings were made on marked bream (fish 1 = 38.3 cm, fish 2 = 31.5 cm F.L.) trained to eat freely in a 1000 × 90 × 250 mm Perspex cuvette (walls 2.5 mm thick) circulated with aerated water (Fig. 1). The fish were trained for several weeks to forage on a particular spot in the cuvette, and conditioned to moderate light intensities, sufficient for light cine filming or video recording. Finally, training with operating X-ray apparatus appeared to be necessary to acclimate the fish to the noise of the apparatus.

X-RAY APPARATUS AND MARKERS

X-ray cine films were made using a Siemens Gigantos X-ray apparatus and a 50 kV Siemens image intensifier (Fig. 1). Radiation by short pulses, which increased the maximal radiation period of the X-ray source, was necessary to study relatively fast movements over longer periods. This, together with absorption of radiation by the water, necessitated intensification of the resulting images. The images were recorded from the intensifier with an Arriflex camera at 26 frames per second using 35 mm Agfa-Gevaert Copex Pan film. Setting of the X-ray apparatus depended largely on the size and composition of the object and its surrounding medium. An optimal contrast was obtained by giving the radiation just enough energy (kV) to penetrate through the object and the water. The product of current

and time (mAs) determined the exposure of the image. Test films, of 30–40-cm F.L. bream at a focus-object distance of 135 cm showed the best results at a setting at 90 kV, 125 mA and 2 ms exposure time, allowing film speeds of 26 frames s^{-1} . Compared to X-ray photographs, such X-ray cine films have weaker resolution, due to the scattering of radiation in the water around the fish and by the intrinsic blurring of the image intensifier. Thus dimensions of the water column to be passed through by X-rays must be kept minimal to reduce both absorption and scattering. This was achieved by using a narrow cuvette in lateral observations. In dorsoventral records the water column was reduced by placing a triangular piece of polystyrene (Tempex) just above the head of the fish (Fig. 1). In addition to these precautions, high contrast markers were required for accurate measurements. Best results were obtained by using pieces of platinum wire (2 mm long, 0.5 mm thick) or tin solder (2 mm long, 0.8 mm thick). Surgical bone screws (6.0 mm long, 1.5 mm diam.) were inserted on the skull to provide a reference grid for measurements. The markers had to be large enough to show up, but not so large as to interfere with normal movements of the head parts. Moreover, larger markers would decrease accuracy in measurements (see below). Platinum markers were placed on the branchial arches to measure inter-arch distances, and in other parts of the head such as lips, buccal lining etc. to analyse their contribution in the overall movement pattern (Fig. 2, Table I).

The markers were implanted in the tissue closely overlying the bones or right into the bones of anaesthetized fish (MS-222, Sandoz, Basel, 75 mg l^{-1}). To implant the marker, it was put inside an injection needle (Anker *et al.*, 1967; Sibbing, 1982; Sibbing *et al.*, 1986) which was connected to a photographic cable release, and thus injected carefully. The positions of the markers were selected to show the excursions of the elements maximal in projection (Fig. 3). For the same reason, the X-ray beam should be in a plane rectangular to that of the marker movement (cf. B' and B'' in Fig. 3). Marker positions were checked by stereo X-ray photographs. On both sides of the cuvette two reference markers (at 4.0 cm distance) permitted calculation of the magnification; they also served as fixed coordinates to record displacements of the fish in the cuvette.

Simultaneously, light films were taken with a Bolex camera at 26 frames per second using 16-mm 250 ASA Kodak double X Negative film, in order to facilitate identification of the feeding actions in the X-ray movies.

SELECTION OF SCENES TO BE ANALYSED

The main criteria for the selection of scenes were as follows. (1) The fish should have a stable position with respect to the screen. (2) When the fish rolls or turns, the marker projections move on the screen, even without actual marker movement (Fig. 3). (Errors in 1 and 2 would make accurate study of the moving parts impossible.) (3) Synchronously-taken light films (video tape or 16-mm film) and reference markers on the skull enable sufficient monitoring of the positions of the fish at subsequent frames. (4) The movements of the markers to be measured lie in a plane roughly parallel to the screen (if this is not the case, projections show up shorter than real distances).

Even after a careful training period, numerous shots should be taken to ensure sufficient scenes meeting all demands listed.

MEASUREMENTS AND CALCULATIONS

From the selected scenes, an enlargement (1.76 × natural fish size) of each frame was projected (Leitz Prado Universal projector provided with a film transport adaptor) on to a sheet of paper. The positions of the reference grid and markers were drawn as tiny dots (0.25 mm) in the centre of each marker spot.

Additional reference points and lines were constructed (from markers and reference grid) in order to calculate particular distances in the direction of motion. The obtained coordinates were digitized with an X-Y data tablet (Summagraphics Supergrid). Distances in subsequent cine frames were calculated by a Digital Minc 11 computer and plotted (Hewlett Packard 74 75 A plotter) in graphs.

ACCURACY

In order to estimate the accuracy of measurements, three possible errors are briefly discussed.

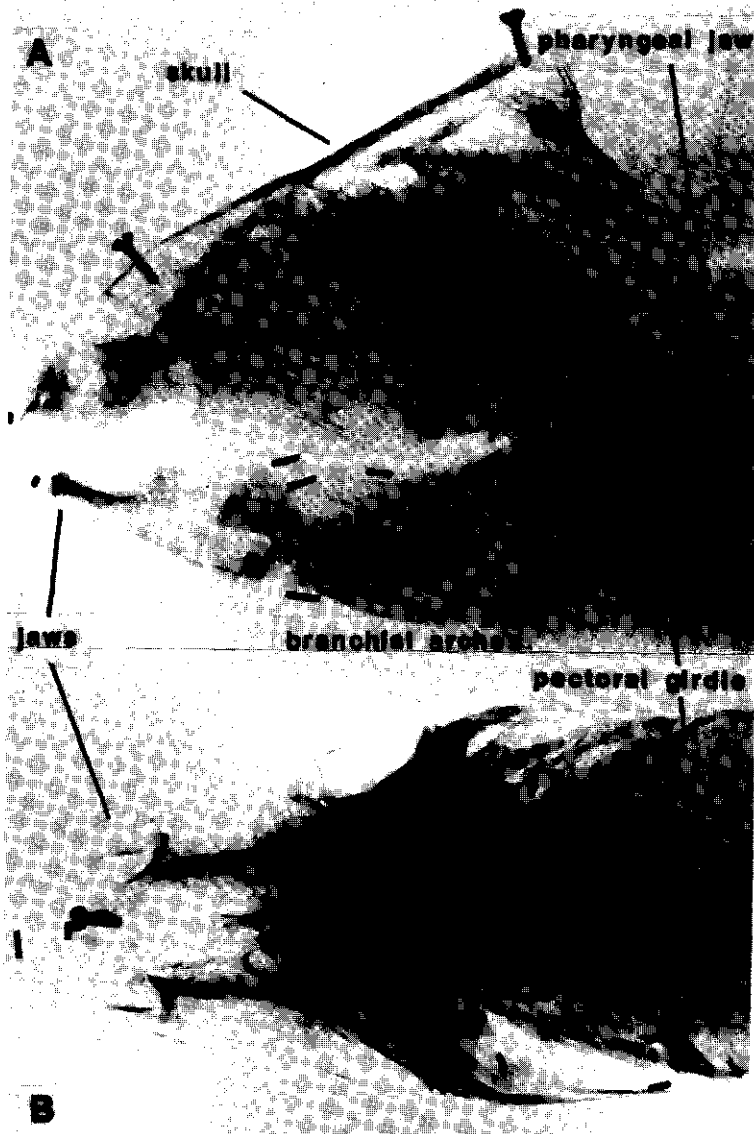

FIG. 2. Lateral (A) and dorso-ventral (B) X-ray photographs of the head of a bream, showing the position of the markers. Note screws in the skull, and pieces of platinum or tin solder on jaws, suspensorium, pharyngeal floor, branchial arches, pharyngeal jaws and opercula.

(1) The X-ray beam is diverging from a point source (focus area 2 mm^2) causing enlarged and blurred marker spots on the screen. The object magnification increases the more it approaches the X-ray source. To minimize these effects, the object distance was made as large as possible within the power limits of the X-ray apparatus. Thus, if the distance from fish to screen decreases from e.g. 12 to 2 cm, the projected inter-marker distance also decreases from 109.7 to 101.5% of its true length. In our study the fish-to-screen distance varied by 2-4 cm, causing an error of 3.28%. A similar type of error occurs when two

TABLE I. Positions and type of markers in the two bream used in the X-ray cine recordings

Marked elements	Position	Fish I (F.L. 38.3 cm)	Fish II (F.L. 31.5 cm)
Neurocranium (rost., caud.)	med.	sc *	sc; ts 0.8-3*
Neurocranium (lateral)	l,r	sc *	ts 0.8-3*
Upper lip	med.	ts 0.8-3*	ts 0.8-4*
Lower lip	med.	ts 0.8-3*	—
Suspensorium	l,r	ts 0.8-4	—
Hyomandibular (dorsal)	l,r	ts 0.8-4	Pt 0.5-1
Hyomandibular (ventral)	l,r	ts 0.8-2	—
Epiphyal	l,r	ts 0.8-4	ts 0.8-3
Opercula	l,r	ts 0.8-3	ts 0.8-2
Ceratobranchial I	l,r	Pt 0.8-3	Pt 0.5-3
Ceratobranchial II	l,r	Pt 0.8-3	Pt 0.5-3
Ceratobranchial III	l,r	Pt 0.8-3	Pt 0.5-3
Ceratobranchial IV	l,r	Pt 0.8-3	Pt 0.5-3
Pharyngeal bone	l,r	ts 0.8-4	ts 0.8-3
Copula communis (pharyngeal floor)	med.	Pt 0.8-3*	ts 0.8-3*
Copula communis (at cb II)	med.	Pt 0.8-3*	ts 0.8-3*
Copula communis (at cb III)	med.	Pt 0.8-3*	ts 0.8-3*
Copula communis (at cb IV)	med.	Pt 0.8-3(2x)*	ts 0.8-3*

*Not used for measurements.

Abbreviations: cb, cerato branchial; F.L., fork length; l, left; med, medial; Pt, platinum marker (0.8 or 0.5 mm thick, 1 or 3 mm long); r, right; sc, screw-marker; ts, tin solder marker (0.8 mm thick, 3 or 4 mm long).

markers in the fish have different distances from the screen. In this experiment however, only small differences occurred (maximum 3 cm), producing maximum errors of 2.4%.

(2) An image intensifier produces increasing deformation of the image towards its periphery. Inaccuracy of measurements at different parts of the screen can be estimated by recording the image of a rectangular grid and analysing its deformation on the film frame. We used a 17 × 17 cm grid of 10.0-mm squares composed of 1.0-mm stainless steel bars. Measurements in different parts of the grid showed increasing deformation towards the edge of the screen. In this study, measurements were only made in the area with errors below 1.59%; thus only c. 52% (a circle with a diameter of c. 100 mm) of the image intensifier screen was used.

(3) Marker positions may be measured inaccurately. In order to estimate the magnitude of error, three cuvette markers were measured 20 times, resulting in three distances $X = 21.45 \pm 0.14$ mm S.D.; $Y = 102.60 \pm 0.37$ mm S.D.; $Z = 6.68 \pm 0.32$ mm S.D.. The relative error in these data varied from 0.67 to 4.73%, standard errors being, respectively, 0.027 mm, 0.070 mm and 0.060 mm. According to the technical specifications, the accuracy of the X-Y data tablet is 0.025 mm.

With all precautions taken in selecting scenes of high quality, the overall inaccuracy in the measuring procedure will be less than the maximal error of about 12%.

III. RESULTS

RESPIRATION

Figure 4 shows the first accurately measured gill arch movements during fish respiration (about 36 ventilations per minute). All data are from dorso-ventral cine records. The almost synchronous abduction of hyoid arches and opercula

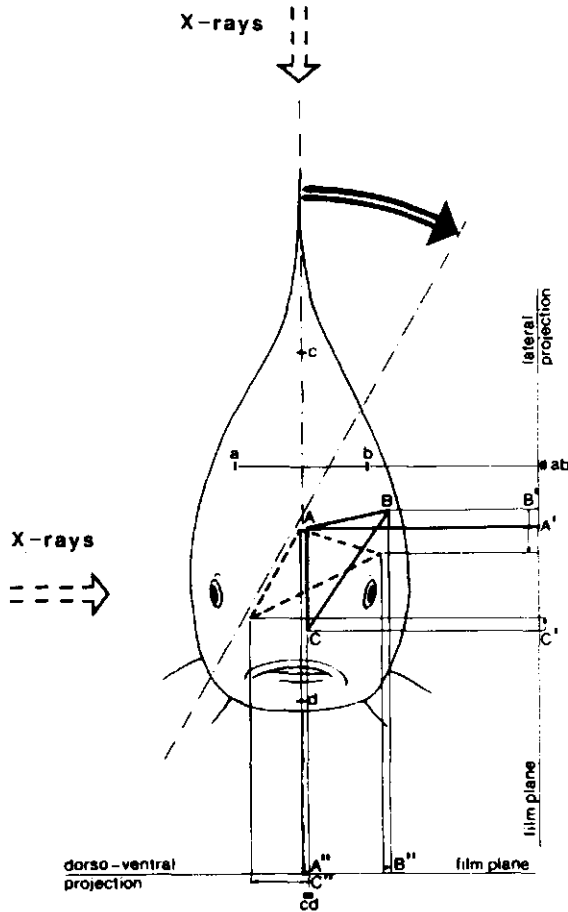

FIG. 3. Marker projections perform varied movements due to body movements of the fish, even without marker-movements within the fish. When the fish rotates as indicated (arrow), markers near the centre of rotation do not move in projection (see A' and A''). With increasing distance from this centre, marker projections show larger excursions (see B' and C'). The size of this effect depends on the direction of the X-ray beam (cf. B'' and C'). Reference markers a, b (lateral projection) and c, d (dorsoventral projection) serve to monitor the position of the fish for selecting appropriate scenes.

(upper four plots) represents the lateral expansion of the buccal and opercular cavities. Whereas buccal expansion and compression have a similar velocity, opercular compression is considerably slower (average 1.02 s) than expansion (average 0.62 s; *t*-test: *t* = 3.58, *n* = 3). Abduction of gill arches (Fig. 4, plots 5–8) proceeds synchronously with volume changes in the buccal cavity. The absolute movement of the series of left cerato-branchials is reconstructed using an accessory point of reference (Rp in Fig. 4, plots 9–13). The first arch had an excursion twice as large as the almost stationary fourth and fifth arch, the latter being the pharyngeal jaw of cyprinids (Sibbing, 1982). The larger excursion of the first arch can be considered as an accumulated movement of arches I–V. However, the actual gill slits between these arches were of about equal size (1.5–2.5 mm; Fig. 5) and hardly changed in width during respiration (Fig. 4, plots 14–17). Since the slits were

BREAM FILTER-FEEDING MECHANISM

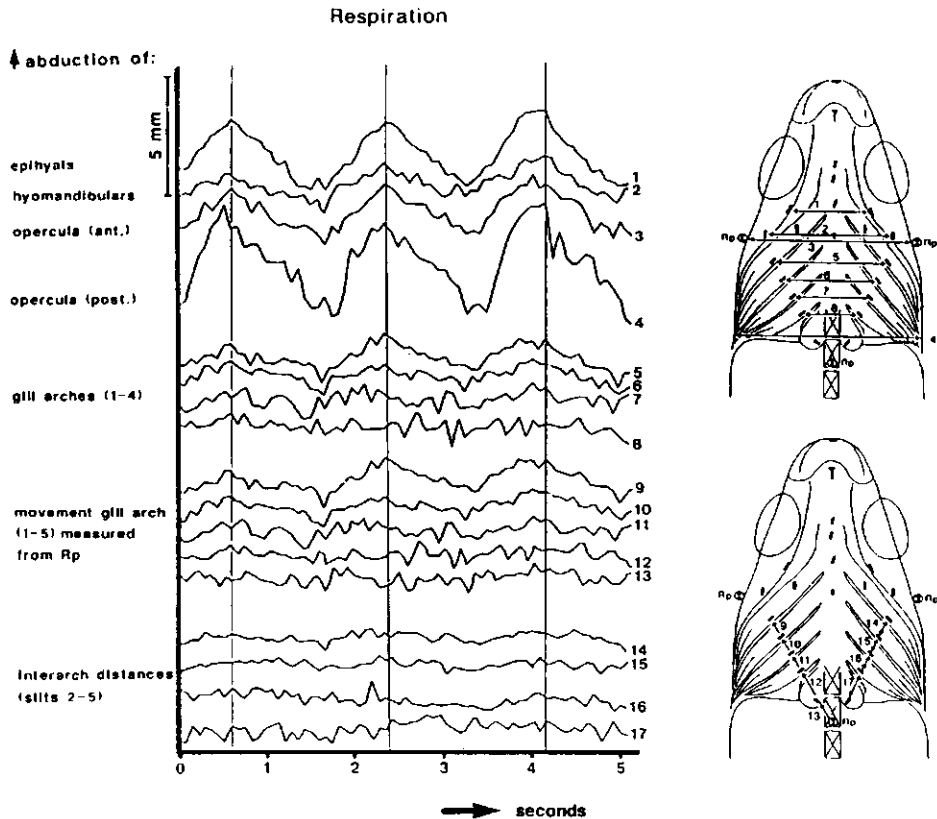

FIG. 4. Movement pattern of head elements during respiration in bream, measured from X-ray cine recordings. Parameters measured are indicated at the right and identified by their plot number. Only changes in amplitude are plotted, not their absolute size. Note the gill-arch movements in plots 5-13; the inter-arch slits, however, remain more or less constant (plots 14-17) during respiration. Rp, reference point.

measured from markings on the arches, these distances include the width of one arch. Therefore, the net slit widths were calculated (Fig. 5). Relatively wide slits were maintained throughout the respiratory cycle, reducing the resistance of flow during irrigation of the gill lamellae.

FEEDING

Bream feed on zooplankton by gulping (Janssen, 1976; Lazzaro, 1987). They take in several particles simultaneously, mainly by slow buccal suction with open angles of the mouth, thus sucking from a wide angle, and they enclose the ingested suspension by protrusion of the upper jaw (Sibbing *et al.*, 1986). The movements of the head parts during gulping on a suspension of *Daphnia pulex* ($0.93 \text{ mm length} \pm \text{s.d. } 0.13 \text{ mm}$) show an almost simultaneous expansion of the buccal and branchial elements, the operculars being slightly delayed (Fig. 6, plot 4).

In respiration, buccal expansion is $116.3\% \pm 3.5\% \text{ s.d.}$ ($n=3$) relative to the adduction phase (100%), while opercular abduction is $110.8\% \pm 0.92\% \text{ s.d.}$ ($n=3$).

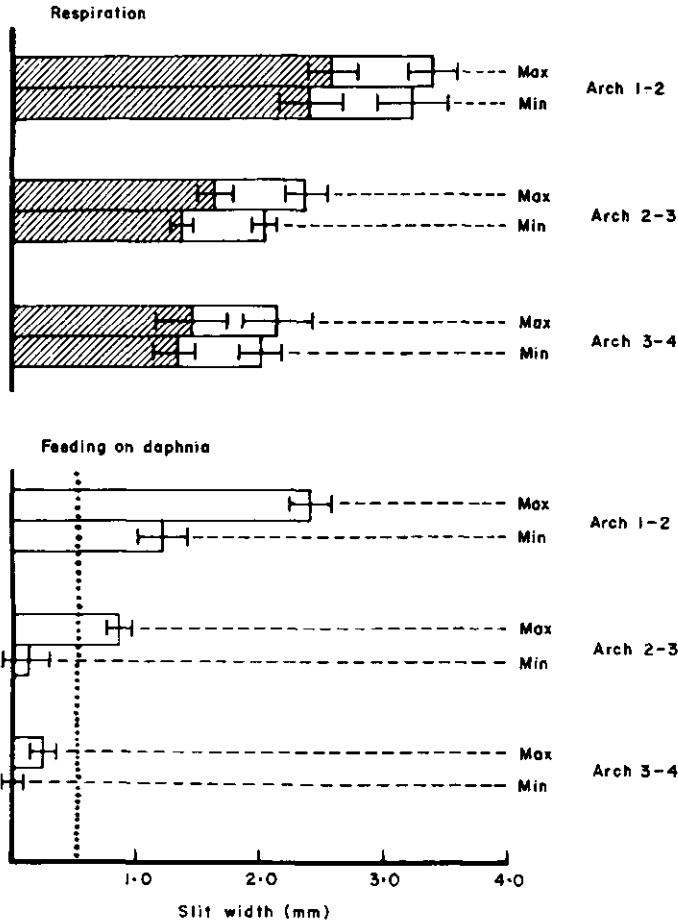

FIG. 5. Diagram showing maxima and minima of the net slits (\pm S.E.) between subsequent gill-arches of bream during respiration (top) and foraging (bottom). The experimental fish were of 31.5 and 38.3 cm F.L., respectively. For comparison, the slit width values of respiration (cross-hatched) were scaled to the larger fish (open bar tips). In the lower graph the mean size of *Daphnia* (0.53 mm) is indicated by a dotted line. Note the different patterns in respiration and feeding. During feeding, the slit between arch 1 and 2 remains too large to retain daphnids.

During gulping, wider lateral expansions occur (Mann-Whitney U test; buccal cavity, $U=9$, $n_1=n_2=3$; operculars, $U=9$, $n_1=n_2=3$) compared to adduction phase (100%); buccal cavity $167.7\% \pm 5.14\%$ S.D. ($n=3$); operculars $131.7\% \pm 0.48\%$ S.D. ($n=3$). Suction during gulping is achieved mainly by buccal expansion, which corroborates with gulping in carp (Sibbing *et al.*, 1986).

Also in filter-feeding, the first branchial arch contributes considerably to the expansion of the branchial basket, with diminishing roles for the posterior arches (Fig. 6, plots 5-13). The net maximal slits between the subsequent arches (about equal in respiration; Fig. 5) differ significantly during gulping (t -test; slit between arches 1-2, $t=10.96$, $n=7$; slit between arches 2-3, $t=13.69$, $n=7$). The second slit is only 35% of the first, and the third only 11%. Significant differences (t -test;

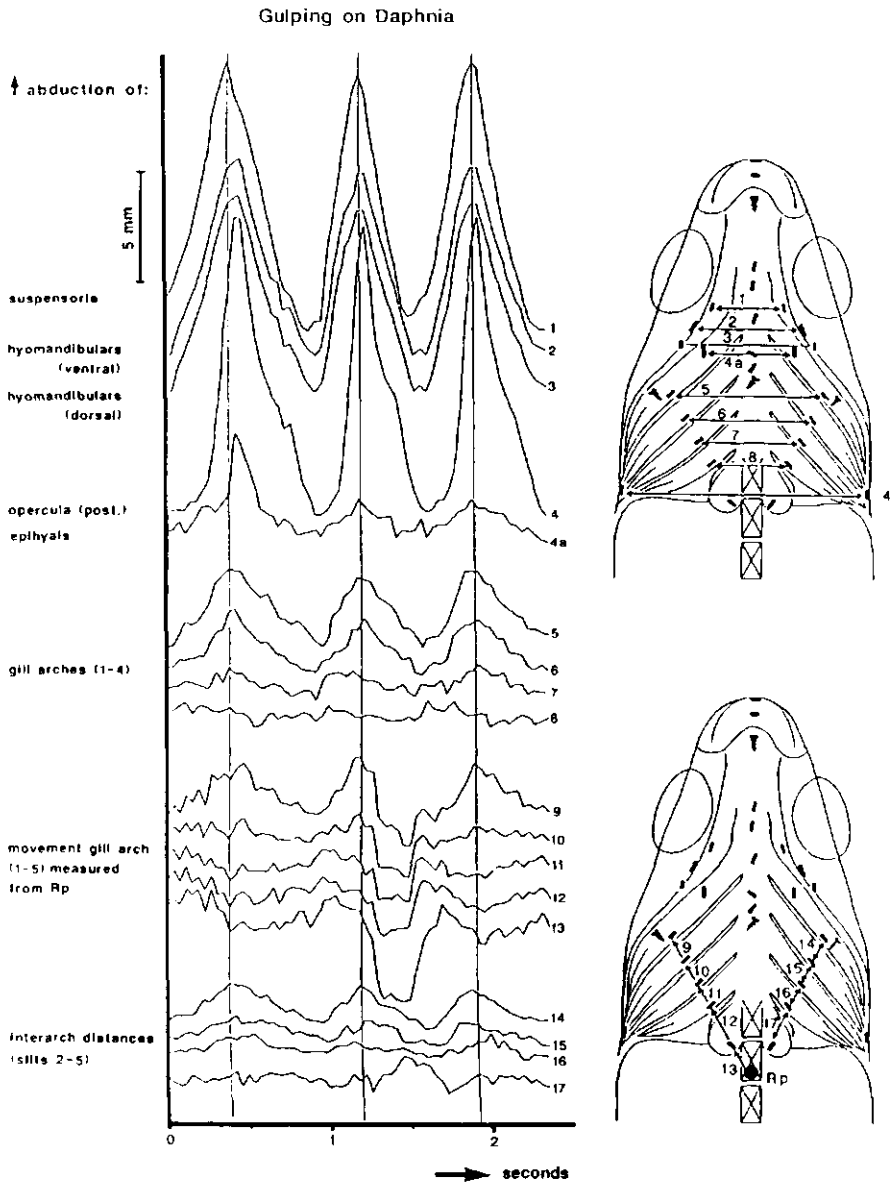

FIG. 6. Movement pattern of bream head elements during filter-feeding (gulping) on *Daphnia pulex* (mean length $0.93 \text{ mm} \pm 0.13 \text{ mm}$) measured from X-ray cine recordings. Parameters measured are indicated at the right and identified by their plot number. Gill-arches move extensively (plots 5-13) as compared to their movement in respiration (Fig. 4); inter-arch slits change distinctly (plots 14-17).

between maximum and minimum of slits between arches 1-2, 2-3 and 3-4, $t = 7.08$, 7.42 and 3.80 , respectively, $n = 7$) between maximal and minimal slit widths occurred during gulping, whereas in respiration only minor differences have been observed (Fig. 5). Also, there was an increase in the posterior movement of the pharyngeal jaw, this movement being transmitted to the other gill-arches. Only the

fourth slit is distinctly wider than usual (Fig. 6, plots 9–13 and 14–17). The arches move in close co-ordination.

IV. DISCUSSION

The complex procedure of training, anaesthetizing, marking and X-ray filming of fish enabled accurate measurements to be made of the minute changes in gill slits of foraging fish.

The experimental procedure could be improved by using X-ray apparatus of greater power, which would permit an increase in object distance and film speed, thus improving the quality considerably. Intensified cooling of the anode would allow longer radiation periods and thus the recording of longer feeding sequences. Only one of the three methods of measuring gill arch movements (Fig. 6, plots 5–8, 9–13 and 14–17, respectively) during the same feeding action demonstrated pharyngeal jaw movement. This emphasizes the need for prior knowledge of the possible direction of movement, to be able to demonstrate some expected movement clearly. These presumed directions determine where markers and reference points should be positioned.

This X-ray study provides the first quantified evidence on gill arch movements during respiration and feeding. Respiration in bream resembles that in carp (*Cyprinus carpio*; Ballintijn, 1969a–c) in its movement pattern: nearly synchronous expansion and compression of the buccal and opercular cavities. No data on gill-arch movements in carp were available. Saunders (1961), from observation of the opercular slits of white sucker, *Catostomus commersoni* (Lacépède), brown bull-head, *Ictalurus nebulosus* (LeSueur), and carp, *Cyprinus carpio* L., found that slits between the successive distal tips of the hemibranchs differ during moderate and intensive breathing. However, no direct information on the actual gill arch slits can be derived from these data. During respiration in a 38.3-cm (F.L.) bream, the anterior inter-arch slits measure 3.5 mm, whereas the average change in their width appears to be about 0.3 mm. This dynamic but very small variation in slit width is new support for the well-known hypothesis (Hughes & Ballintijn, 1965; Alexander, 1970, 1974) that the flow over the gills remains nearly constant through the cycle of expansion and compression of the head cavity. This reduces the energy spent on gill irrigation, because the water is kept at a constant momentum.

If the hypothesis holds that particle retention occurs in a slit formed between opposite rakers of two adjacent gill-arches, then a constant inter-arch slit is expected, at least during the sieving period of the feeding action. Comparing the movement patterns of respiration and gulping, such a sieving period with steady slits during compression has not been observed (Fig. 6, plots 14, 15, 16). In addition, the width of the inter-arch slit should be related to the size of the prey, if selective particle retention is required. Minimal slit widths during gulping are indeed smaller than in respiration. However, the net slit between arches 1 and 2 remains considerably wider (2 mm; Fig. 5) than the mean size of the daphnids fed (0.93 mm long, 0.57 mm wide and only 0.35 mm thick). For effective retention, a net inter-arch slit of 0.5 mm or smaller and a homogeneous filter (Boyd, 1976; Rubenstein & Koehl, 1977) was expected. The present study shows relatively wide slits between arches 1 and 2, while the slits between other arches were significantly smaller. This implies a non-homogeneous filter, in which the largest amounts of

water will go through the largest gaps, resulting in an inefficient filtering system. Thus, a proportional number of prey will be lost through the widest slit, where adequate retention is improbable. The loss could be reduced by conducting the water over the narrow slits only, reducing the effective filter surface considerably.

The present results do not support the hypothesis of size-selective retention in filter-feeding bream by inter-arch slit adjustment. This may be due to the relatively simple two-dimensional model with inter-arch slits discussed here. The complex three-dimensional structure of the branchial basket suggests a different hypothesis of the filter mechanism and will be discussed in another paper.

The present method gives us a tool to study in detail the processes of gill arch movements and particle retention during filter-feeding in fish. It helps to quantify the structural and functional parameters which might be critical in branchial sieving, and thus aids in explaining the success of bream in eutrophic freshwater lakes. Functional morphological knowledge of the filtering mechanism in fish may thus provide a rational basis for explaining trophic segregation and predator-prey interactions in aquatic systems.

We thank Mrs A. Kroon (Wageningen) for participation in the production of the X-ray movies, Professor Dr P. Dullemeijer (Leiden) for the use of the X-ray apparatus, Dr J. Vijverberg for review drafts of this paper, Dr G. Houghton for improving the English text, Miss M. F. van Eijk for typing several versions of the manuscript, and Mr W. Valen for preparing the figures. The investigation was supported by the foundation for Fundamental Biological Research (BION) which is subsidized by the Netherlands Organization for Scientific Research (NWO). Project 811-437-241B.

References

- Alexander, R. McN. (1970). Mechanics of the feeding action of various teleost fishes. *J. Zool., Lond.* **162**, 145-156.
- Alexander, R. McN. (1974). *Functional Design in Fishes*. London: Hutchinson. 160 pp.
- Anker, G. C., Simons, J. & Dullemeijer, P. (1967). An apparatus for direct X-ray cinematography exemplified by analysis of some respiratory movements in *Gasterosteus aculeatus*. *Experientia* **23**, 74, 1-8.
- Ballintijn, C. M. (1969a). Functional anatomy and movement coordination of the respiratory pump of the carp (*Cyprinus carpio* L.). *J. exp. Biol.* **50**, 547-567.
- Ballintijn, C. M. (1969b). Muscle co-ordination of the respiratory pump of the carp (*Cyprinus carpio* L.). *J. exp. Biol.* **50**, 569-591.
- Ballintijn, C. M. (1969c). Movement pattern and efficiency of the respiratory pump of the carp (*Cyprinus carpio* L.). *J. exp. Biol.* **50**, 593-613.
- Boyd, C. M. (1976). Selection of particle sizes by filter-feeding copepods: a plea for reason. *Limn. Oceanogr.* **21**, 175-180.
- Hughes, G. M. & Ballintijn, C. M. (1965). The muscular basis of the respiratory pumps in the dogfish. *J. exp. Biol.* **43**, 363-383.
- Janssen, J. (1976). Feeding modes and prey size selection in the alewife (*Alosa pseudoharengus*). *J. Fish Res. Bd Can.* **33**, 1972-1975.
- Lammens, E. H. R. R. (1984). A comparison between the feeding of white bream (*Blicca bjorkna*) and bream (*Abramis brama*). *Verh. int. Verein. Limnol.* **23**, 886-890.
- Lammens, E. H. R. R. (1986). Interactions between fishes and the structure of fish communities in a Dutch shallow, eutrophic lake. Unpubl. thesis, Agricultural University, Wageningen.
- Lammens, E. H. R. R., Geursen, J. & MacGillavry, P. J. (1987). Diet shifts, feeding efficiency and coexistence of bream (*Abramis brama*), roach (*Rutilus rutilus*) and white bream (*Blicca bjoerkna*) in hypertrophic lakes. *Proc. Vth Congress Europ. Ichthyol. Stockholm* **1985**, 153-162.

- Lazzaro, X. (1987). A review of zooplanktivorous fishes: their evolution, feeding behaviours, selectivities and impacts. *Hydrobiologia* **146**, 97–167.
- Liem, K. F. (1986). The pharyngeal jaw apparatus of the Embiotocidae (Teleostei): a functional and evolutionary perspective. *Copeia* **1986**, 311–323.
- Matthes, H. M. (1963). A comparative study of the feeding mechanisms of some African Cyprinidae (Pisces, Cypriniformes). *Bijdr. Dierk.* **33**, 3–35.
- Rubenstein, D. L. & Koehl, M. A. R. (1977). The mechanism of filter-feeding: some theoretical considerations. *Am. Nat.* **111**, 981–994.
- Saunders, R. L. (1961). The irrigation of the gills in fishes. I. Studies of the mechanism of branchial irrigation. *Can. J. Zool.* **39**, 637–653.
- Sibbing, F. A. (1982). Pharyngeal mastication and food transport in the carp (*Cyprinus carpio* L.): a cineradiographic and electromyographic study. *J. Morph.* **172**, 223–258.
- Sibbing, F. A., Osse, J. W. M. & Terlouw, A. (1986). Food handling in the carp (*Cyprinus carpio* L.): its movement patterns, mechanisms and limitations. *J. Zool., Lond.* **210**, 161–203.
- Sibbing, F. A. (1988). Specializations and limitations in the utilization of food resources by the carp, *Cyprinus carpio* a study of oral food processing. *Env. Biol. Fishes* **22**, 161–178.
- Zander, E. (1906). Das Kiemenfilter der Teleosteer, eine morphophysiologische studie. *Zeitschr. Wiss. Zool.* **84**, 619–713.

A New Model of Particle Retention and Branchial Sieve Adjustment in Filter-Feeding Bream (*Abramis brama*, Cyprinidae)

Wim Hoogenboezem

Department of Experimental Animal Morphology and Cell Biology, Agricultural University, Marijkeweg 40, 6709 PG Wageningen, The Netherlands

and

Limnological Institute, Tjeukemeer Laboratory, De Akkers 47, 8536 VD Oosterzee, The Netherlands

Jos G. M. van den Boogaart and Ferdinand A. Sibbing

Department of Experimental Animal Morphology and Cell Biology, Agricultural University, Marijkeweg 40, 6709 PG Wageningen, The Netherlands

Eddy H. R. R. Lammens

Limnological Institute, Tjeukemeer Laboratory, De Akkers 47, 8536 VD Oosterzee, The Netherlands

and Arie Terlouw and Jan W. M. Osse

Department of Experimental Animal Morphology and Cell Biology, Agricultural University, Marijkeweg 40, 6709 PG Wageningen, The Netherlands

Hoogenboezem, W., J. G. M. van den Boogaart, F. A. Sibbing, E. H. R. R. Lammens, A. Terlouw, and J. W. M. Osse. 1991. A new model of particle retention and branchial sieve adjustment in filter-feeding bream (*Abramis brama*, Cyprinidae). *Can. J. Fish. Aquat. Sci.* 48: 7-18.

A new model for filter feeding in bream (*Abramis brama*, Cyprinidae) is presented based on the three dimensional architecture of the branchial sieve. Transverse ridges on the upper surface of the gill arches form a system of channels in which food particles appear to be retained. These ridges are formed by a fleshy interconnection between the middle part of the gill arch and the bony parts of its gill rakers. Muscles attached to the rakers, present only on the lateral edge of the gill arch, indicate movability of the lateral bony raker element. If the fish is foraging on particles smaller than the channel diameter, movement of these gill rakers probably adjusts the sieve by reducing the channel diameter of the opposite channel. Selectivity of bream depends on available size classes of zooplanktons and changes in selectivity are attributed to adjustment of the branchial sieve. The channel model has been tested with feeding experiments and X-ray cinematography. The reconstructed paths of marked food particles show that particles follow the hypothesized path. Particle retention occurred mainly at the expected medial site of the arches. Our study strongly supports the channel model of particle retention.

On présente un nouveau modèle d'alimentation par filtration chez la brème (*Abramis brama*, Cyprinidae), modèle fondé sur la structure tridimensionnelle du filtre branchial. Des crêtes transverses situées à la face supérieure des arcs branchiaux forment un système de canaux qui semblent retenir les particules de nourriture. Ces crêtes sont formées par un pont charnu situé entre la partie centrale de l'arc branchial et les parties osseuses de ses branchicténies. Les muscles fixés aux branchicténies, présents uniquement sur le bord latéral de l'arc branchial, indiquent la possibilité de mouvement de l'élément raclleur osseux latéral. Si le poisson se nourrit de particules dont le diamètre est inférieur à celui du canal, le mouvement de ces branchicténies ajuste probablement le filtre en réduisant le diamètre du canal opposé. La sélectivité de la brème dépend de la taille du plancton disponible et les modifications de sélectivité sont attribuées à l'ajustement du filtre branchial. Le modèle des canaux a été testé par des expériences d'alimentation et par radiocinématographie. La reconstitution du trajet des particules de nourriture marquées montre que ces dernières suivent le trajet prévu. La rétention des particules s'est surtout produite là où on l'avait prévue, c'est-à-dire au point médian des arcs branchiaux. Les résultats de notre étude appuient fortement le modèle des canaux dans la rétention des particules.

Received December 15, 1989

Accepted July 23, 1990

(JA407)

Reçu le 15 décembre 1989

Accepté le 23 juillet 1990

Among the European cyprinids, bream (*Abramis brama*, Cyprinidae) is one of the most effective feeders on both zooplankton and benthic chironomids (Lammens 1984; Lammens and Hoogenboezem 1991) and the dominant fish species in eutrophic lakes with limited macrophytes in north-western Europe. Efficient exploitation of both benthic and pelagic prey seems contradictory. Hyatt (1979) described that branchial sieves of benthic feeders usually possess short gill rak-

ers whereas zooplanktivorous species usually have elongated gill rakers. Although the branchial sieve of bream bears relatively short rakers as for example, compared with *Clupea* (Kirchhoff 1958; Gibson 1988), our experiments (Lammens 1985; Lammens et al. 1987) show unequivocally that bream forage successfully on zooplankton.

Size selectivity in filter-feeding fishes is usually related to interraker distances, which are taken as a measure of mesh size.

Predictions of size selectivity vary from relatively good (Wright et al. 1983; Drenner et al. 1984) to data showing hardly any relationship between size of ingested particles and interraker distances (Seghers 1975). Fishes may even retain particles smaller than predicted from their interraker distances (Gibson 1988). It was also found that removal of gill rakers of *Tilapia* had no effect on the size of ingested particles (Drenner et al. 1987). Thus, the actual sieving mechanism is more complicated than simple sieving through a filter (Rubinstein and Koehl 1977).

Until recently, particle retention in fish species with short rakers was thought to occur according to a simple two-dimensional interarch slit model. This model, first proposed by Zander (1906) and which seems to be generally accepted (Greenwood 1953; Matthes 1963; Lammens 1984; Northcott and Beveridge 1988), assumes narrow and more or less adjustable slits between adjacent gill arches forming the actual site of retention (Fig. 1A). These slits have a serrated appearance due to the interdigitation of gill rakers of both arches. Therefore, slit width between the arches should be related to the size of food particles. Thus, when feeding on small items, a narrow interarch slit is expected, but foraging on larger prey allows larger slits, enabling reduction of the sieve's resistance to water flow and increasing its capacity. The first attempt to test this hypothesis, by means of X-ray cinematography (Hoogenboezem et al. 1990), showed that the gill-arch slits are far too large (1.25–2.5 mm between arch 1 and 2) to explain the size of the ingested cladocerans (length 0.93 mm). A second condition for effective particle retention is constant interarch slits during sieving. However, these slits change constantly during filter feeding. (Hoogenboezem et al. 1990). Thus the simple two-dimensional model of particle retention appeared to be inadequate to explain the sieve mechanism.

In the present study a new model of particle retention and sieve adjustment is developed using the three-dimensional architecture of the branchial sieve. Food particles appear to be retained in channels on the upper surface of the branchial arch (Fig. 1B). We first describe the morphological and histological features of the branchial sieve and the results of feeding experiments which form the basis of the new model. We then describe a series of tests to which the model was subjected. Among these

tests is the study by X-ray cinematography of the pathways of food particles during feeding.

Material and Methods

Bream for dissections and histological and feeding experiments were trawled in Tjeukemeer, a shallow, eutrophic lake in the north of The Netherlands.

Morphology and Histology

Bream specimens (24.7, 27.0, and 33.0 cm standard length (SL)) for paraffin sections were decapitated immediately after capture. The complete branchial basket, including the palatal organ, was fixed in Bouin's fluid for 15 d (Romeis 1968). After rinsing with 70% ethanol, the material was decalcified in a mixture (1:1) of formic acid (100%) and ethanol (70%) for 30 d. The mixture was renewed every week. After a dehydration series over ethanol the material was impregnated over isoamylacetate with liquid paraffin in a vacuum stove at 60°C for 2 h and subsequently embedded in paraffin. Serial sections (5 µm) were cut, mounted on a slide, and stained after Crossmon (Romeis 1968).

For morphological studies, either fresh, frozen, or Formalin-fixed (4%) material was used.

Feeding Experiments

Bream of 18.0, 20.0, and 22.5 cm fork length (FL) were kept in an aquarium (180 × 60 × 60 cm) at 18°C and fed on living zooplankton for at least 1 mo before the experiments started. Four trials at high and three at low density were conducted. Before each experiment the fish were starved for 24–32 h. After adding freshly collected live zooplankton to the experimental tank, density and size distribution were determined by taking 12 water samples of 200 mL with a perspex tube at 12 sites. The 12 samples were filtered through an 80-µm plankton net and the zooplankton were preserved in 4% Formalin. The total volume of water was measured to the nearest 5 mL. The zooplankton lengths, excluding caudal spine and helmet, were measured to the nearest 0.02 mm using an ocular

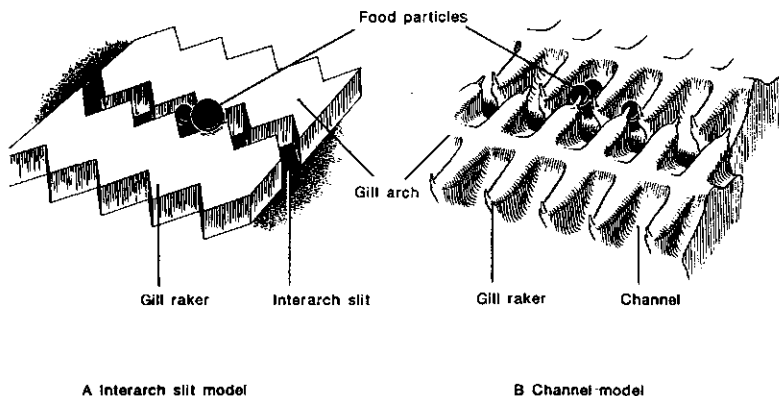

FIG. 1. (A) Scheme of the "interarch slit model" of particle retention. A serrated slit is formed by two adjacent gill arches. The supposed retention area is formed by the interdigitating gill rakers. (B) In the "channel model," food particles are expected to be retained in a channel formed by two adjacent gill rakers.

micrometer and were arranged in 15 length classes of 0.11 mm. This procedure was repeated after 2 h.

X-Ray Cinematography

Lateral and dorsoventral X-ray cine recordings were made of bream foraging in a perspex cuvette (1000 × 90 × 250 mm) provided with a measuring frame (Hoogenboezem et al. 1990). The experimental fish were marked with pieces of platinum wire (2–3 mm long, diameter 0.5 mm) in order to monitor the position and activity of the fish. Marks were placed on the skull (four markers), on the upper and lower jaws, pharyngeal jaw, and on the cleithrum. Branchial arches (I–IV) were marked anteriorly and posteriorly on the ceratobranchial bone. Markers in the palatal organ were implanted just underneath the epithelium. Lateral and dorsoventral movies were recorded at 55–65 kV, 170 ± 10 mA, and object distance 85 cm with exposure times of 1–5 ms (see Hoogenboezem et al. 1990 for details). The films were recorded with an Arriflex 35-mm motion picture camera using Agfa Gevaert CopeX Pan film at 25, 50, or 80 frames per second. The width of the pharyngeal slit, between roof and bottom of the mouth, was measured from lateral X-ray movies of a bream (25.5 cm SL) with marked gill arches and palatal organ. Paths of food particles in the mouth and branchial sieve were measured with marked *Daphnia pulex*. A small iron sphere (diameter 1 mm) was glued to the carapace (Bison Super glue) of a frozen *Daphnia* (length approximately 1 mm), which made it sink immediately. Two or three marked prey were mixed with ± 50 unmarked dead *Daphnia* and placed on the bottom (area approximately 100 cm²). This high number of *Daphnia* was needed to initiate feeding in the bream. The low number of marked specimen allows the recognition of a single intraoral path of a *Daphnia*. The fish (25.5 cm SL with two platinum markers per arch (I–IV)) was recorded in dorsoventral X-ray movies while feeding on this mixture. Simultaneous video recordings were taken to observe the behaviour of the fish.

Location of Food Particles on the Sieve

The retention site of prey in the branchial sieve was determined in freshly collected fish specimens trawled from Tjeukemeer. Dissected branchial sieves were scanned with a stereomicroscope. Retained prey were identified, measured, and their exact location in the sieve recorded.

Results

Morphology of the Branchial Sieve

Macromorphology

The branchial sieve of bream consists of four paired gill arches, each bearing two rows of gill rakers (Fig. 2A). The fifth arches are modified into the characteristic cyprinid pharyngeal jaws (Sibbing 1982; Sibbing 1991a) and bear only an anterior row of gill rakers. As Sibbing (1988) found in carp (*Cyprinus carpio*), bream have a large muscular palatal organ forming the roof of the mouth and covering the entire branchial sieve, leaving only a narrow pharyngeal slit between branchial arches and palatal organ. The interarch slits constitute little to the total surface area of the branchial sieve (slits plus arches with channels). The area of arches I and II forms more than 75% of the total surface area of the branchial arches.

Micromorphology

Gill rakers — Each gill raker is composed of a cushionlike structure forming a transverse ridge and a distal bony part. The transverse ridge runs between the bony raker element and the central area of the arch. The central area is a low longitudinal ridge where both the lateral and medial raker cushions meet (Fig. 2B). The space between two adjacent transverse ridges forms a narrow channel, which is approximately 1 mm wide and 2–3 mm long in a 25-cm bream. Such channels appeared to be the site of particle retention (Fig. 2C). The bony part of the gill raker will further be referred to as the raker and the term channel will be applied to the space between two adjacent transverse ridges.

In the first gill arch, the medial channels are distinctly longer (70% of the arch width) than the lateral channels, and a distinct curvature can be seen in the former (Fig. 2B). In the second arch these differences are smaller. In arches III and IV the lateral and medial channels are equal in length and not distinctly curved. In the small area of the epibranchial bones (dorsal parts of the arches), transverse ridges, gill rakers, and channels are poorly developed.

The bony elements of the rakers rest with their base against the gill arch, run through the connective tissue cushion, and protrude from the distal parts of the transverse ridges. The rakers lying at the lateral side of the arch possess a long spine and have a spindle-shaped bony base, with their axis parallel to the arch (Fig. 3A). This form allows rotation of the raker during abduction or adduction through a pad of compact connective tissue (Fig. 4A). The medial rakers are somewhat shorter (Fig. 3B). They have broad flattened bases enveloped in connective tissue which is applied closely to the underlying bony ceratobranchials. These envelopes are interconnected and impede any movement in articulation (Fig. 4b).

Gill-raker muscles — Two striated muscles are attached to each of the lateral bony rakers of each gill arch. The first, the musculus abductor branchiospinalis, consists of a sheet of muscle fibers connecting the lateral gill raker, just above the raker base (Fig. 4A). Bijtel (1949) described this muscle for several fish species and called it the abductor muscle for the gill filaments. Since its actual function is probably abduction of the gill raker, musculus abductor branchiospinalis may be a more appropriate name. The second is the musculus interbranchiospinalis, a thin elongated muscle running between two adjacent gill rakers. It consists of a short muscle bundle at both ends tapering into a relatively long tendon, attaching at slightly different levels on the basis of both gill rakers (Fig. 4A). The function of this muscle is not known.

In contrast with the previous two muscles, the musculus constrictor canalis interbranchiospinalis is found on both the lateral and medial sides of the gill arch and is not attached to the bony rakers. The muscle originates under the ceratobranchial bone, runs over the ventral edge under the channel floor, and radiates into both channel walls. Here it forms a complex network of muscle fibers (Fig. 4A and 4B). Contraction of this muscle may cause deformation of the transverse ridges, affecting channel length and/or channel diameter.

Retention Site of Particles and Feeding Experiments

During the dissection and study of branchial sieves, we found prey items in the above-described channels. Also in sections for reconstruction work, we found parts of cladocerans in these channels (Fig. 2C).

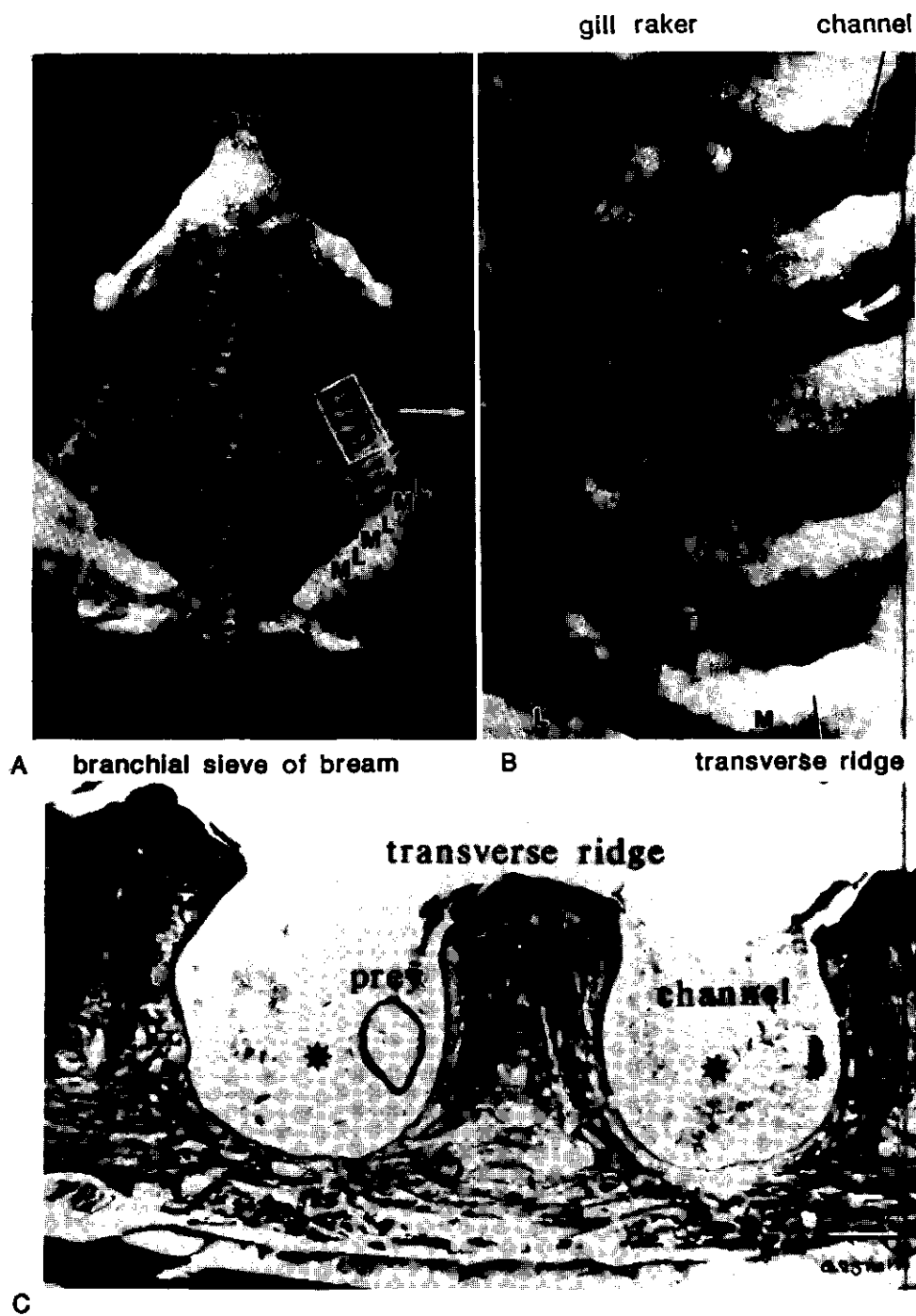

FIG. 2. (A) Dorsal view of the branchial basket of an adult bream, 37.4 cm SL. (B) Detail of two adjacent gill arches (right, arches I and II). L=lateral area; M=medial area; C=central area. Note the curved medial channels in the first arch (arrow). (C) Cross-section through two

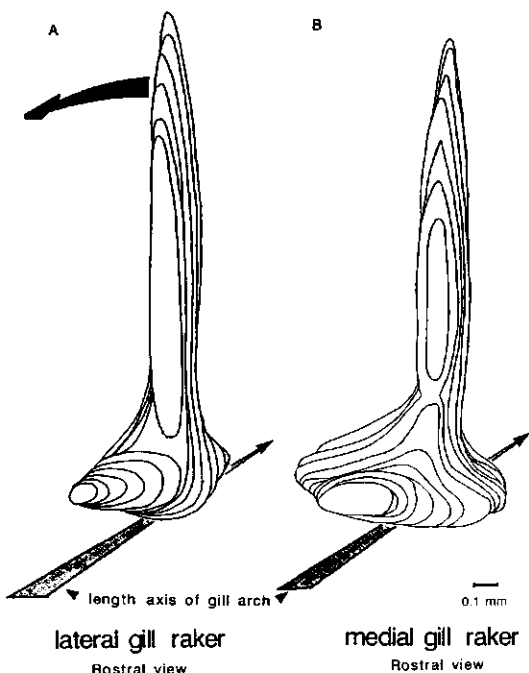

FIG. 3. Reconstructions (from serial sections) of lateral and medial bony gill-raker elements. Note the (A) spindle-shaped basis of the lateral gill raker and the (B) broad flattened basis of the medial gill-raker. The arrows at the bottom indicate the length axis of the ceratobranchial bone. The arrow at the top indicates the possible rotation of the movable raker.

Small bream (<15 cm SL) are mainly particulate feeders and visual prey location is probably the decisive factor in food selection (Lammens 1985). Filter-feeding bream (mostly larger than 15 cm SL) take a series of snaps not directed at individual prey. Seven feeding experiments with bream (20 cm FL) were performed in aquarium tanks. In all experiments, the majority of the zooplankton consisted of cladocerans. The average composition was *Daphnia hyalina* (57.5%), *Bosmina coregoni* (22.4%), *B. longirostris* (8.1%), *D. cucullata* (0.2%), *Ceriodaphnia reticulata* (0.2%), *Chydorus sphaericus* (0.5%), and cyclopoid copepods (11.1%). Differential evasive behaviour of cladocerans and copepods could influence the selectivity (Drenner et al. 1978). In our experiments, 88% of the prey were nonevasive cladocerans, a suitable composition for unbiased tests on selectivity by bream. The selectivity for certain size classes of zooplankton depended on density and size distribution. In four trials (mean feeding time 2.0 h) at high density (416 ind/L), bream were strongly selective and ingested only prey larger than 0.9 mm (large/small prey ingestion ratio 10.6; Fig. 5A). The prey densities at t_0 and t_1 did not differ significantly for particles <0.9 mm (t -test: $t = 0.612$; $n = 6$), and for prey >0.9 mm the density after feeding was significantly lower than t_0 (t -test: $t = 6.553$; $n = 8$). Under conditions of

low prey density (51.3 ind/L) (Fig. 5B), the same fish now included small prey (>0.5 mm) in its diet and the large/small prey ingestion ratio was 1.32. For particles <0.9 mm the observed difference was just below the significance level of 5% (t -test: $t = 2.052$; $n = 6$); the density of prey >0.9 mm decreased significantly (t -test: $t = 6.098$; $n = 8$) after feeding. Video recordings of the high-density trials showed gulping bream. In the environment the ratio of large to small zooplankters was approximately 1.5. Thus in the high-density experiments, small particles are also inhaled but they are not retained in contrast with what we observed in the low-density experiments with the same fish. Although small particles are ingested less efficiently, this selectivity is considered different from the results of high-density experiments (cf. Wright et al. 1983). This shift in size selectivity of bream most probably resulted from adjustment of the branchial sieve.

New Model of Particle Retention and Sieve Adjustment

From our observations we conclude the following: (1) the interarch slits are too wide for effective particle retention, and moreover, a mechanism of interdigitating gill rakers results in a nonhomogeneous filter system, e.g. a filter with different sized pores, in which the largest amount of water will go through the largest gaps (Hoogenboezem et al. 1990); (2) the morphology of the pharyngeal cavity, with the palatal organ as a roof and the branchial arches as a perforated floor, seems to be "designed" for water flow conduction through the channels; (3) food particles are captured in the described channels; and (5) the results of our feeding experiments indicate an adjustable filter system in bream; and (5) the movable lateral gill rakers and the associated muscles may accomplish the observed filter adjustment.

Mechanism of Particle Retention

We developed the following conception of the mechanism of particle retention and branchial sieve adjustment in bream as follows. Ingested water including zooplankton flows through the narrow slit between palatal organ and branchial arches. Large particles (>3 mm) are retained in this pharyngeal slit. From the curved form of the channels (arches I and II) the flow of water containing smaller food particles is expected to run mainly through the medial channels towards the interarch slit (Fig. 6). Retention of intermediate-sized particles (1–2 mm) occurs in the channels on the branchial arches. The smallest ingested particles (0.5–1.0 mm) are retained only in medial channels with reduced mesh size. Effective reduction of the channel diameter is assumed to be achieved by insertion of the movable lateral rakers, of the opposite gill arch, into these medial channels. The channel opening is reduced to half its size when the raker insertion is centrally in the opposing channel. The effective diameter is in fact even slightly smaller if the width of the raker tip is taken into consideration.

According to this hypothesis the following is expected: (1) the pharyngeal slit between the palatal organ and the branchial basket is kept narrow during feeding, causing a parallel current along the gill arches. This improves water conduction through the channels because the total surface of the arches with

FIG. 2. (Concluded) medial channels. Note the position of the prey (*Bosmina* sp.) between the walls of the channel and the place (asterisk) where the movable opposite raker is supposed to be during filtering.

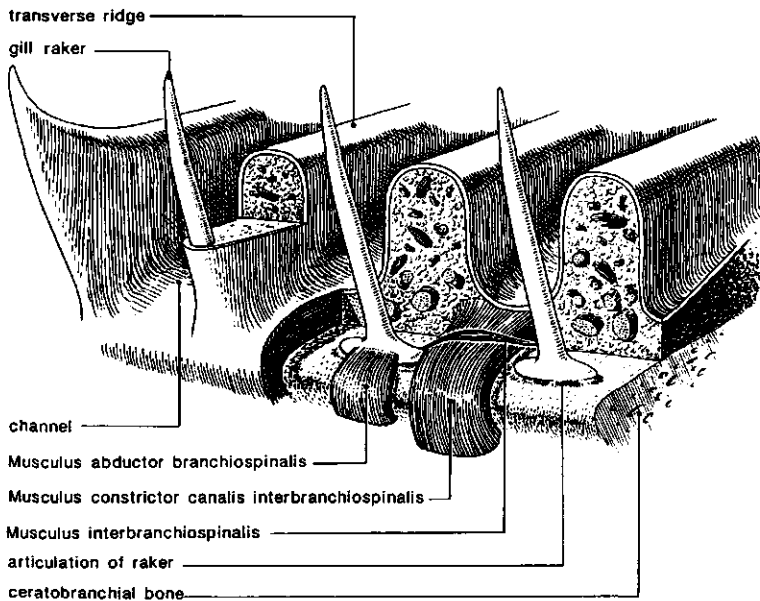

A scheme of lateral view

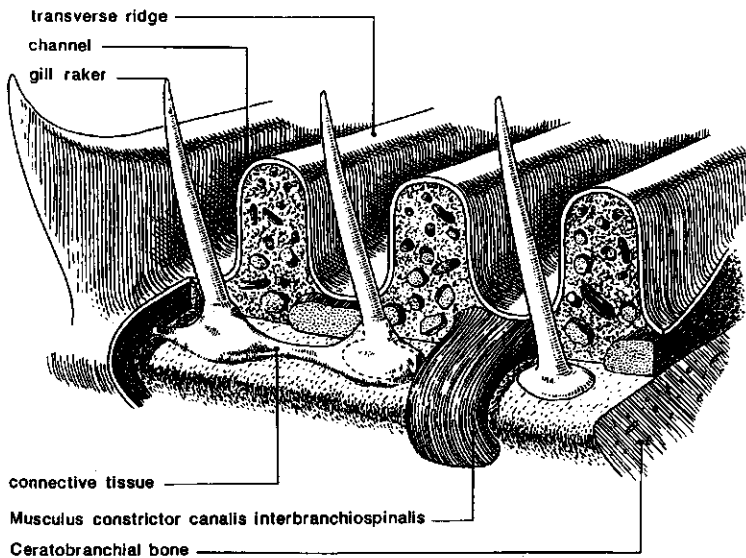

B scheme of medial view

FIG. 4. Scheme of the (A) lateral and (B) medial views of the gill arch indicating the positions of the gill rakers, muscles, and the connective tissue between gill-raker base and ceratobranchial bone.

Size selectivity of 20-cm bream

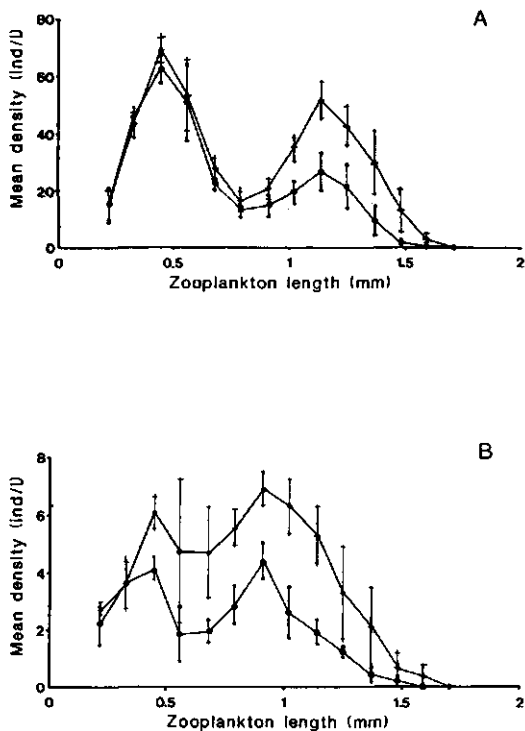

FIG. 5. Feeding experiments of bream (mean length 20.2 cm FL) foraging on living zooplankton. The mean densities of several experiments were plotted as a function of zooplankton size class. (A) Feeding at high prey density (mean = 416 ind/L \pm SE $n = 4$) at the start (t_0) (+) and after 2.0 h (t_1) (●). (B) Feeding at low prey density (mean = 51.3 ind/L \pm SE; $n = 3$) at the start (t_0) (+) after 2.16 h (t_1) (●).

channels far exceeds the area of the interarch slits; (2) food particles follow a path parallel to the arch and turn with a distinct angle (approximately 90°) into a channel where the particles are retained; (3) small particles are retained predominantly in the median channels because only these channels can be reduced in cross-sectional area by the movable rakers; (4) only two size ranges of food particles are ingested, one related to the channel diameter and the second to half the channel diameter; and (5) the width of the interarch slits may not exceed the length of the movable rakers.

Experimental Tests of the Model

Pharyngeal slit

According to the present model the vertical distance between the palatal organ and the branchial sieve is expected to be narrow during filtering. The variation of the pharyngeal slit was measured at several locations along the arch, from anterior to posterior (Fig. 7C and 7D, plots A-E). In a scene with chironomids as food items the maximal slit varies from 4.5 mm anteriorly to 3 mm posteriorly. While foraging on *D. pulex*, an even smaller maximal slit is observed (3 and 1.6 mm, respectively) (Fig. 7). The bream can open its pharyngeal slit considerably

wider, up to 14 mm anteriorly at arch 2 (mean slit 11 ± 1.5 mm SD). Such wide slits were observed when bream fed on *Limax* sp., a slug measuring approximately 20 mm long and 10 mm wide.

Path of food particles

Small food items were expected to follow a path along the gill arch and turn sharply (approximately 90°) into a channel where they would be retained. Such a path was followed using X-ray cine recordings of a marked bream foraging on marked *D. pulex*. Simultaneous video recordings showed that unmarked *Daphnia* were also inhaled, and no particle loss through the opercular slits was observed. The paths of 188 specimens of *D. pulex* during uptake and sieving have been studied in X-ray scenes. One hundred and forty-one prey specimens (75%) did not show a distinct angle in their path. The conglomerate of *Daphnia* and the iron sphere may be too large to enter the channel; the conglomerate is approximately 1 mm long, 1.5 mm wide, 0.4 mm thick. Retention probably occurred not in the channels, but in the pharyngeal slit between the palatal organ and the branchial arches (Fig. 8D). Carp similarly selects larger particles (Sibbing et al. 1986; Sibbing 1991b). Nevertheless, the paths of 47 (25%) of the prey particles showed the expected flexion clearly. Of these particles entering the channels, only 7 (15%) turned distinctly laterally and the rest, 40 (85%), turned sharply in the medial direction just before being retained in the channel. Some examples of these paths are plotted relative to the nearest marked gill arch (Fig. 8). Arriving dorsally near the sieve, the particles followed the branchial arch before turning into a channel (Fig. 8A-8C). As expected in a large filter area, compared with the relatively small volume of the buccal cavity, the velocity of marked particles decreased considerably when they reached the gill-arch area (mean velocity in buccal cavity 114.9 cm/s \pm 62.8 SD; $n = 25$; filter area 11.1 cm/s \pm 7.7 SD; $n = 29$). An example considered as pharyngeal slit retention is plotted in Fig. 8D. Two simultaneously ingested particles are seen to follow an arch and are retained without any curvature. In the trace in Fig. 8E, a particle above arch I suddenly turns laterally, up to 1.7 mm beside the branchial bone. Shortly after, it flows back in the mediocaudal direction, probably entering a medial channel to be retained at the medial edge of arch I.

Location of particles on the sieve

Zooplankton particles were found in the channels of the branchial sieve of 20-35 cm FL bream freshly collected from the lake. Because large amounts of mucus adhering to the gill arches often made tracing of food particles impossible, only fish lacking such large quantities of mucus were suitable for investigation. Therefore, only 23 fish were studied. In these specimens, 29 prey items were found in the channels. Of the 29 items, four *D. hyalina* and one *B. coregoni* were traced in lateral channels. Their lengths varied from 0.56 to 1.28 mm (mean length 1.03 mm \pm 0.41 SD; $n = 3$). Five times more specimens of *D. hyalina* and *B. coregoni*, varying from 0.36 to 1.6 mm (mean length 0.75 \pm 0.36 mm SD; $n = 24$), were found in the medial channels. The mean length of the particles found laterally is expected to be larger, but the low number of lateral retained prey precluded identification of statistically significant differences in prey size. Occasionally, particles were observed on the central area of the gill arch (mean length 0.67 \pm 0.27 mm SD; $n = 4$).

If water is divided equally over both lateral and medial channels, it is expected that (larger) zooplankters are found in equal

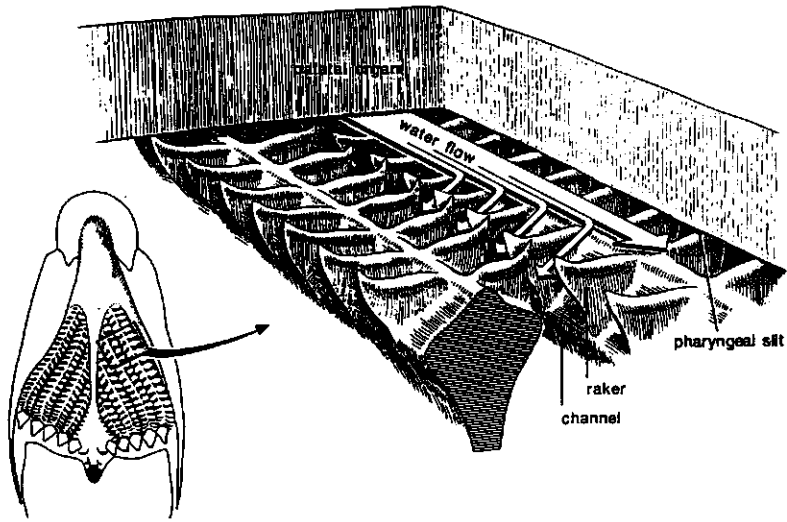

FIG. 6. Water flow (arrows) over the gill arch (right, arches I and II) and through the channels. Note the narrow pharyngeal slit; the water is forced to flow in a plane parallel to the arch and through the channels.

numbers laterally as well as medially (binomial distribution). However, we found a pattern significantly favouring the medial channels. Of 29 individual zooplankton traced in the channels, only 5 were found laterally. The lengths of the channels differ laterally and medially, especially in the first two arches. The mean asymmetry of the four gill arches was measured and resulted in different retention probabilities for particles laterally ($p = 0.56$) and medially ($p = 0.44$). According to a binomial distribution, with 29 prey items, the expected number for the medial channels (16.2 ± 2.7 SD) was significantly different from the observed (24) number (U -test: $U = 2.90$; $p = 0.0019$; $n = 29$) closely agrees with the percentage of marked *Daphnia* distinctly turning in the medial direction (85%) as observed in the X-ray cine recordings (see section on path of food particles).

Selectivity in feeding experiments

The feeding experiments (Fig. 5A and 5B) at high and low zooplankton density corroborate the two expected ranges of prey size. The size of ingested prey >0.9 mm is close to the diameter of the channels (0.82 mm) in 20-cm bream. The same fishes gulping at low food density retain all prey types >0.5 mm, coinciding with half of the channel diameter (0.41 mm).

Discussion

Three main aspects of the channel model (water flow, particle retention, and sieve adjustment) have been studied here. Our results support the validity of the model.

Water Flow

The architecture of the filter apparatus in bream appears to be designed to conduct water in a discrete direction. First, the palatal organ influences the flow distinctly by leaving only a narrow pharyngeal slit between the roof and floor. It was shown that only minor variations in slit width occurred (Fig. 7). Inges-

tion of larger prey induced clearly larger slits. During filter feeding the slit is considered small (1.6–3 mm) enough to conduct the water and particles parallel to the branchial arches into the channels.

Gill-arch movements have been measured in filter-feeding bream (Hoogenboezem et al. 1990). The interarch slits were wide relative to the daphnids ingested. Compared with the width of the gill arch, however, the interarch slits are relatively narrow. At maximal abduction of the gill arches the interarch slits occupy only 20% of the branchial surface. Thus, at least 80% of the surface of the sieve is occupied by the branchial arches. Consequently, the main bulk of water enters above the arches and will flow from the arch surface towards the interarch slits. The structure of the first arch is likely to conduct the water in the medial direction. The medial channels of the first arch are distinctly curved, from a longitudinal direction at the centre of the arch, towards a real transverse position at the medial end of the channel. Such a design would effectively conduct the water medially. Since the total area of the outlets of the medial channels is of the same order of magnitude as the area of the interarch slits, no major changes in the velocities of the streaming fluid will occur at this site. During filter feeding there may be, as in respiration (cf. Johansen 1977), a high resistance at the site of the gill filaments, when both functions are simultaneously executed. However, we do not know if this happens.

The elongated lateral gill rakers (first arch) are more or less paddle shaped and point more anteriorly than laterally in order to conduct the water medially. The well-developed lateral raker muscles in the first arch may serve in retaining such a spatial orientation during feeding.

The reconstructed paths of food items serve as indicators for flow directions in the branchial sieve. From particles small enough to enter the channels, 85% turned a medial direction and only 15% laterally. This confirms a mainly medial-directed flow over the sieve, as expected from morphological observations.

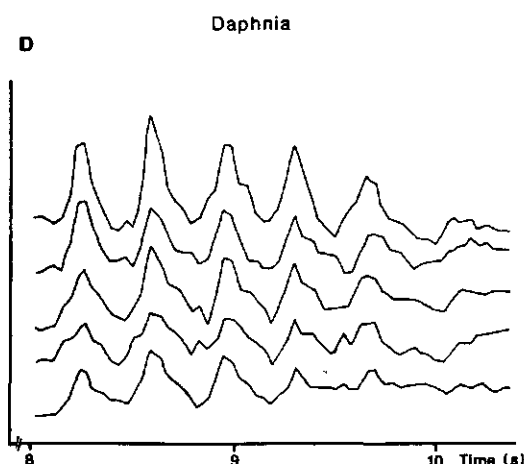
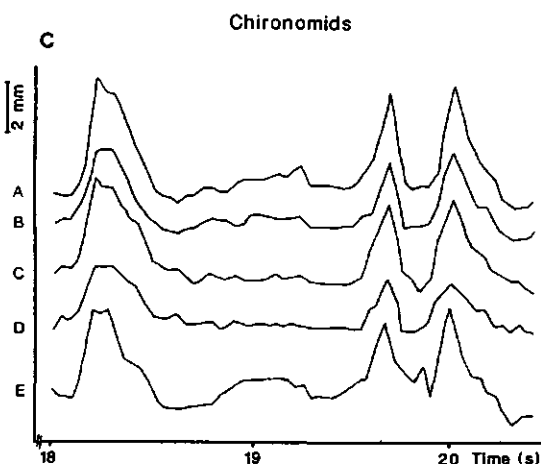
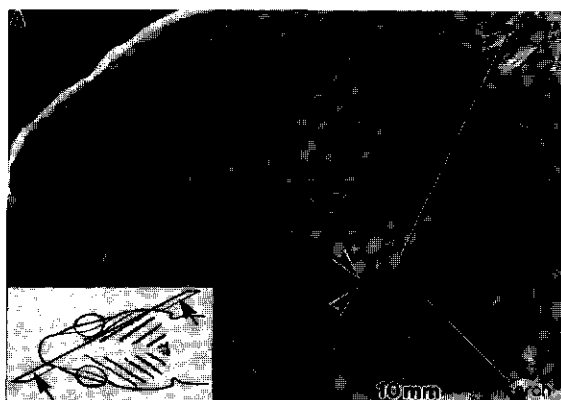

FIG. 7. Pharyngeal slit measurements in bream during feeding. (A) Section through the head of a bream parallel to the gill arch (see inset). Note the narrow slit between palatal organ and gill arch (arrowheads). (B) Positions (X-ray photograph) of platinum markers and the distances measured in an experimental fish (A–E). (C) Changes in the pharyngeal slit during feeding on chironomids (three snaps) and (D) daphnids (five snaps). Only changes in amplitude are plotted, not their absolute size, as a function of time. Note the irregular pattern while feeding on chironomids and the very regular pattern while foraging on *Daphnia*.

Particle Retention

The slit between branchial basket and palatal organ is also a retention site for larger particles (>2 mm). Sibbing et al. (1986) described such a retention mechanism in carp.

Drenner et al. (1987) conducted feeding experiments with *Tilapia galilaea*, feeding on a mixture of zooplankton and synthetic microspheres. Surgical removal of gill rakers and microbranchiospinae did not affect particle ingestion rates or selectivity. For the retention of larger particles (>0.5 mm) these results are not conclusive, since Drenner et al. (1987) did not include a description of the zooplankton decrease in these experiments. The largest particles they used (diameter 0.07 mm) were approximately 7 times smaller than the mean interraker distance (approximately 0.5 mm), while the space between two microbranchiospines was approximately 1.8 times the largest microsphere. This species may have a different retention mechanism for very small particles (<0.07 mm).

The lateral movable rakers of the first arch are distinctly the longest of the rakers in the sieve. Their tips probably reach to

the palatal organ to form a sieve which might prevent loss of larger (>1 mm) zooplankters through the slit between the operculum and the first gill arch. Although these rakers are longer than any other found in the sieve, they are shorter than those found in clupeids (Gibson 1988) and coregonids (Seghers 1975). The discrepancy between interraker distance and the mean size of ingested particles as found in *Coregonus clupeaformis* (Seghers 1975) is probably caused by two factors. First, experimental fish were particulate feeders, feeding by directing their snaps towards individual visually selected prey. Second, almost all available prey were larger than the interraker distance; thus even incidentally ingested small prey were still large enough to be retained. In our view the zooplankton distribution was not appropriate to determine the retention capability of this species. Fishes in both families often have extremely long rakers on the first arch; in this type of fish the food particles will be strained mainly through this sieve of elongated gill rakers. The narrow pharyngeal slit in cyprinids does not require very long rakers and the elongated rakers of the first arch only pre-

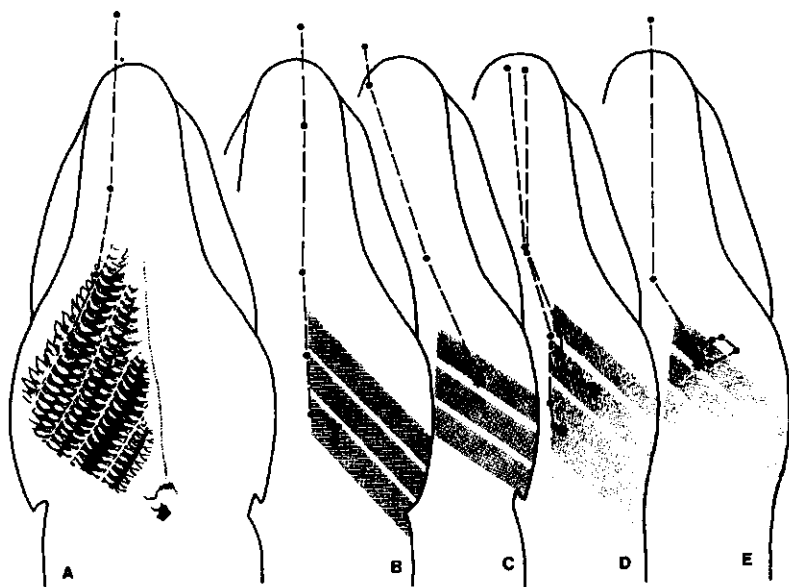

FIG. 8. Paths of marked food items (*Daphnia pulex*) in relation to the branchial sieve measured from X-ray cine recordings (see text for explanation). Solid circles represent subsequent film frames (A, 50 frames/s; B-E, 80 frames/s). Asterisks indicate the retention site of the particles. The position of the gill arches (shaded areas), reconstructed from gill-arch markers, is indicated for reference.

vent loss of large prey. The peculiar orbit depicted in Fig. 8E may show the effect of these rakers. The marked *Daphnia* only reached a maximum distance of 1.7 mm lateroanterior of the first arch, which is shorter than the mean length (2.41 ± 0.44 mm SD; $n = 27$) of the lateral gill raker of the first arch.

Small- and medium-sized cladocerans (0.36–1.6 mm) appeared to be retained in the channels, thus supporting the channel model of filtering.

Sieve Adjustment

Experimental conditions will influence the feeding mode, e.g. bream >15 cm are usually filter feeding at high food density, but at low density even large fish may feed as a particulate feeder (Lammens 1985; Lammens and Hoogenboezem 1991). Differences between these feeding modes involve the uptake of water and particles (Sibbing et al. 1986). In both cases the actual retention occurs after the prey have been inhaled. In our high-density feeding experiments, gulping bream inhaled but did not retain numerous small-bodied cladocerans. In the low-density trials, however, these small particles were inhaled and retained. This density-dependent selectivity is considered to indicate sieve adjustment. Two groups of particle sizes were ingested (Fig. 5), depending on density and size distribution of the food. At high density, fish retain particles >0.9 mm, but at low density they also retain particles >0.5 mm. The present channel model predicts two settings of the filter apparatus in bream. The first setting should be related to the channel diameter and the second is expected to be about half the channel diameter.

The smallest class of retained food items (0.5–1 mm) is assumed to be captured in diameter-reduced channels, although no direct observations of sieve adjustment by gill-raker activity are available. Channel reduction is probably achieved by inser-

tion of a movable lateral raker into a medial channel of the adjacent arch (Fig. 9). The presence and insertion of the musculus abductores branchiospinalis at only these lateral rakers and their flexible cushions, combined with the spindle-shaped raker bases, strongly suggest lateral abduction of the raker. Electrical stimulation of the lateral raker area in anaesthetized fish (W. Hoogenboezem, pers obs.) showed distinct lateral depression of the raker tips. In the paddlefish (*Polyodon spathula*), movable gill rakers were described by Imms (1904). As in bream, the raker muscles in paddlefish interconnect the outside of the gill raker and the cartilage of the branchial arch. Imms (1904) suggested that the gill-raker muscles pull the rakers outward. He further hypothesized that elastic fibres between the gill raker and the branchial arch serve as antagonists and reposition the raker after its movement. The function of the musculus interbranchiospinalis is still unclear; it may aid in fine longitudinal adjustment to point the raker tip exactly in the centre of the opposing channel, when channel and raker are not properly aligned. Mechanoreceptors at these sites have been demonstrated by De Graaf et al. (1987). The third muscle system, the musculus constrictor canalis interbranchiospinae (lateral and medial), may by its contraction change the shape or length of the transverse channels, which may cause distal translation of the bony raker.

The varying interarch slit, as measured from X-ray cine recordings (Hoogenboezem et al. 1990), has a range perfectly fitting the channel model (Fig. 9). At maximal abduction of the gill arches, e.g. 2.5-mm slit between arches 1 and 2, the tip of the depressed movable raker is just in the outlet of the opposite channel. During gill-arch abduction the raker penetrates further into the channel (Fig. 9). The maximal effective interarch slit during filter feeding is related to the length of the gill raker. wider slits (>2.5 mm between arches 1 and 2) cause a decrease

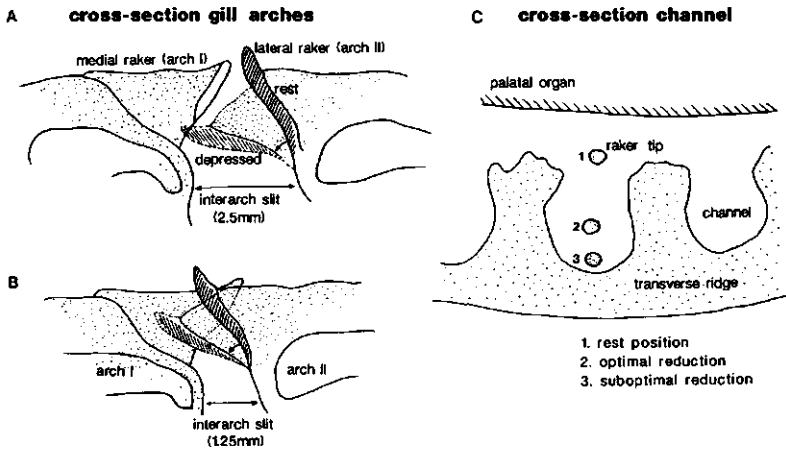

FIG. 9. Cross-sections through gill arches I and II (redrawn from photographs). (A) At interarch slit 2.5 mm, the (depressed) movable raker just reaches the outlet of the filter channel. (B) Minimal abducted situation. Over the whole compression phase, the raker can be kept in a fixed position relative to the channel, resulting in a constant mesh size during the sieve phase. (C) Possible raker-tip positions: 1, rest position of the raker not influencing the channel diameter; 2, raker reduces the channel to half its diameter; 3, the low position causes a heterogeneous filter with a narrow slit between the raker and channel bottom but large gaps between the raker and channel walls.

of retention ability, since the raker tip cannot be brought into the medial channel. Thus, effective retention in diameter-reduced channels is possible when the interarch slits do not exceed the movable raker length. Within these limitations, the channel filter-feeding model is independent of gill-arch movements, and a certain mesh size can be maintained during these actions. A constant mesh size during the compression phase of the oral cavity is important for effective retention, and for the effective use of the filter area as a whole. A filter with big holes will result in a major flow through these perforations and very little through the tinier meshes. When the model of interarch slits is considered, such a uniform filter is lacking (Hoogenboezem et al. 1990). In the present model the raker tip can also be inserted close to the bottom of the channel (Fig. 9). The area beneath the tip then represents a fine-meshed filter but the gaps on both sides of the tip remain large (approximately half the channel diameter). This results in a heterogeneous system within the channel. Particles even larger than half the channel diameter will escape through the enlarged gaps. Thus, to keep a more or less uniform mesh size, the raker is to be placed into the central area of the channel. Considering that channel diameters increase during the course of development (W. Hoogenboezem, pers. obs.), larger bream (>30 cm SL; channel diameter >1.27 mm) probably always feed with reduced channels on zooplankton.

The presence of mucus on the branchial sieve may implicate a "sticky filter" (Rubinstein and Koehl 1977). Changing size selectivity with changing zooplankton availabilities, however, cannot be explained with a sticky filter model. Besides, phytoplankton should then also be captured; however, there is no evidence for this, as determined by gut content analysis. Mucus may be a transport medium for small particles from the channels over the wide interarch slits to the chewing cavity and oesophagus. Two different types of oral mucus have been found in carp and related to intraoral food processing (c.f. Sibbing and Uribe 1985). Mucus also seems to play an important role

in preventing loss of small particles in bream (W. Hoogenboezem and J. G. M. van den Boogaart, in prep.).

Integration of functional-morphological and ecological knowledge and techniques allowed us to develop and test hypotheses on the filter mechanism of the bream. The channel model not only describes the mechanism of particle retention, but it also determines the fraction of the food resources available to bream. Future comparisons of potential food resources for coexisting cyprinids may give clues for the success of bream in European eutrophic waters.

Acknowledgements

We are indebted to Drs. J. Vijverberg (Oosterzee), R. D. Gulati, and O. van Tongeren (Nieuwersluis) for their critical remarks on the various manuscript drafts, to Bert van den Bergh and Trudi Machielsen (Wageningen) for their assistance in the muscle reconstructions, and to Annet Kroon and Yvette van Vugt (Wageningen) for collecting data. Two anonymous referees are acknowledged for their constructive comments and Dr. J. Daly for improving the English text. We also thank Mr. W. Valen who drew some of the illustrations. Dr. G. Hoedemaker and Mr. C. Pootjes (Academic Medical Centre, Amsterdam) are acknowledged for making a Tacarno 35-mm movie analyzer available. The investigation was supported by the Foundation for Fundamental Biological Research (BION), subsidized by The Netherlands Organization for Scientific Research (NWO), Project 811-437-241B.

References

- BUTEL, J. H. 1949. The structure and the mechanism of movement of the gill-filaments in teleostei. *Arch. Neerl. Zool.* 8: 1-22.
- DE GRAAF, P. J. F., C. M. BALLINTUN, AND F. W. MAAS. 1987. Mechanoreceptor activity in the gills of the carp. I: Gill filament and gill raker mechanoreceptors. *Respir. Physiol.* 69: 173-182.
- DRENNER, R. W., J. R. MUMMERT, F. DE NOYELLES, JR., AND D. KETTLE. 1984. Selective particle ingestion by a filter-feeding fish and its impact on phytoplankton community structure. *Limnol. Oceanogr.* 29: 941-948.

- DRENNER, R. W., J. R. STRICKLER, AND W. J. O'BRIEN. 1978. Capture probability: the role of zooplankton escape in selective feeding of zooplanktivorous fish. *J. Fish. Res. Board Can.* 35: 1370-1373.
- DRENNER, R. W., G. L. VINYARD, K. D. HAMBRIGHT, AND M. GOPHEN. 1987. Particle ingestion by *Tilapia galilaea* is not effected by removal of gill rakers and microbranchiospines. *Trans. Am. Fish. Soc.* 116: 272-276.
- GIBSON, R. N. 1988. Development, morphometry and particle retention capability of the gill rakers in the herring, *Clupea harengus* L. *J. Fish Biol.* 32: 949-962.
- GREENWOOD, P. H. 1953. Feeding mechanism of the cichlid fish, *Tilapia esculenta* Graham. *Nature (Lond.)* 172: 207-208.
- HOOGENBOEZEM, W., F. A. SIBBING, J. W. M. OSSE, J. G. M. VAN DEN BOOGAART, E. H. R. R. LAMMENS, AND A. TERLOUW. 1990. X-Ray measurements of gill-arch movements in filter feeding bream (*Abramis brama*, Cyprinidae). *J. Fish Biol.* 36: 47-58.
- HYATT, K. D. 1979. Feeding strategy. In W. S. Hoar, D. J. Randall, and J. R. Brett [ed.] *Fish physiology*. Vol. VIII. Academic Press, New York, NY.
- IMMS, A. D. 1904. Notes on the gill-rakers of the spoonbill sturgeon *Polyodon spathula*. *Proc. Zool. Soc. Lond.* 2: 22-35.
- JOHANSEN, K. 1977. Respiration and circulation. In A. G. Kluge [ed.] *Chordate structure and function*. 2nd ed. Collier MacMillan, New York, NY.
- KIRCHHOFF, H. 1958. Funktionell-anatomische Untersuchung des Viseralapparatus von *Clupea harengus* L. *Zool. Jb. Anat.* 76: 461-540.
- LAMMENS, E. H. R. R. 1984. A comparison between the feeding of white bream (*Blicca bjoerkna*) and bream (*Abramis brama*). *Verh. Int. Ver. Limnol.* 22: 886-890.
1985. A test of a model for planktivorous filter feeding bream *Abramis brama*. *Environ. Biol. Fishes* 13: 288-296.
- LAMMENS, E. H. R. R., J. GEURSEN, AND P. J. MACGILLAVRY. 1987. Diet shifts, feeding efficiency and coexistence of bream (*Abramis brama*) Roach (*Rutilus rutilus*) and white bream (*Blicca bjoerkna*) in hypertrophic lakes. *Proc. V. Cong. Eur. Ichtyol.* 153-162.
- LAMMENS, E. H. R. R., AND W. HOOGENBOEZEM. 1991. Diets and feeding behaviour. In I. J. Winfield and J. S. Nelson [ed.] *The biology of cyprinid fishes*. Chapman and Hall, London.
- MATTHES, H. M. 1963. A comparative study of the feeding mechanisms of some African cyprinidae (Pisces, Cypriniformes). *Bijdr. Dierkd. Amsterdam* 33:3-35.
- NORTHCOTT, M. E., AND M. C. M. BEVERIDGE. 1988. The development and structure of pharyngeal apparatus associated with filter feeding in tilapia (*Oreochromis niloticus*). *J. Zool. Lond.* 215: 133-149.
- ROMEIS, B. 1968. Mikroskopische technik. Munchen-Wien, Oldenbourg.
- RUBINSTEIN, D. L., AND M. A. R. KOEHL. 1977. The mechanism of filter-feeding: some theoretical considerations. *Am Nat.* 111: 981-994.
- SEGHERS, B. H. 1975. Role of gill rakers in size selective predation by lake whitefish, *Coregonus clupeaformis* (Mitchill). *Verh. Int. Ver. Limnol.* 19: 2401-2405.
- SIBBING, F. A. 1982. Pharyngeal mastication and food transport in carp (*Cyprinus carpio* L.): a cineradiographic and electromyographic study. *J. Morphol.* 172: 223-258.
1988. Specializations and limitations in the utilization of food resources by the carp, *Cyprinus carpio*: a study of oral food processing. *Environ. Biol. Fishes* 22: 161-178.
- 1991a. Food processing by mastication in fish. In J. F. V. Vincent and P. J. Lillford [ed.] *Feeding and texture in food*. S. E. B. Seminar Ser. 43.
- 1991b. Food capture and oral processing. In I. J. Winfield and J. S. Nelson [ed.] *The biology of cyprinid fishes*. Chapman and Hall, London.
- SIBBING, F. A., J. W. M. OSSE, AND A. TERLOUW. 1986. Food handling in the carp (*Cyprinus carpio*): its movement patterns, mechanisms and limitations. *J. Zool. Lond.* 210: 161-203.
- SIBBING, F. A., AND R. URIBE. 1985. Regional specializations in the oropharyngeal wall and food processing in the carp (*Cyprinus carpio* L.). *Neth. J. Zool.* 35(3): 377-422.
- WRIGHT, D. I., W. J. O'BRIEN, AND C. LUECKE. 1983. A new estimate of zooplankton retention by gill rakers and its ecological significance. *Trans. Am. Fish. Soc.* 112: 638-646.
- ZANDER, E. 1906. Das Kiemenfilter der Teleostei, eine morphophysiologische studie. *Wiss. Zool.* 84(4): 619-713.

A MODEL FOR SWITCHING BETWEEN PARTICULATE-FEEDING AND FILTER-FEEDING IN COMMON BREAM, Abramis brama

Wim Hoogenboezem^{***}, Eddy H.R.R. Lammens^{*}, Yvette van Vugt^{***} and Jan W.M. Osse^{**}.

Key words: Snap frequency, Zooplankton density, Buccal cavity, Swimming speed, Energy costs, Cyprinidae.

Synopsis

A model has been developed to describe the process of switching between particulate- and filter-feeding in common bream (Abramis brama) in relation to fish size and zooplankton density. The model assumes that the encounter rate of fish and zooplankton is determined by the zooplankton density and the swimming speed of the fish. However, if zooplankton density is so high as to allow at least one prey to be engulfed per random snap, the encounter rate is determined by the volume of the buccal cavity and by the zooplankton density, but is independent of swimming speed. The snapping frequency will be maximal at the time of switching, decreasing with increasing zooplankton density because of extra time needed for intra-oral prey handling. The model predicted switching from particulate- to filter-feeding only for bream > 15 cm standard length at zooplankton densities < 500 l⁻¹. The snap frequency of six sizes classes of bream (7.5, 10.4, 12.5, 15, 24 and 29.5 cm) was measured at varying densities of Daphnia. The model predictions for snap frequencies of all size classes corresponded to the highest values observed. The average of the observed snap frequencies was only 50% of the predicted values, probably because the calculated average distance between preys assumes an ideal swimming route of the fish and error-free vision for particulate-feeding whereas the handling time was ignored.

^{*} Limnological Institute, De Akkers 47, 8536 VD Oosterzee, The Netherlands

^{**} Department of Experimental Animal Morphology and Cell Biology, Agricultural University, Marijkeweg 40, 6709 PG Wageningen, The Netherlands

Introduction

The abundance of common bream, *Abramis brama* (L.), has strongly increased in The Netherlands due to eutrophication. An additional food resource is provided by the abundant planktonic crustaceans (Lammens et al. 1987; Loffler 1984). Lammens (1985) observed two feeding modes in bream: particulate-feeding (PF), i.e. visual selection of prey which are swallowed one by one, and filter-feeding (FF), i.e. several prey being engulfed by a series of undirected snaps (Jansen 1976, Lammens 1985, Lammens & Hoogenboezem 1991). In choosing its diet bream is confronted with alternatives at least three successive steps: (1) the place of foraging, i.e. benthic or pelagic; (2) the mode of feeding, it can decide between particulate- and filter-feeding; (3) the size and species of food organisms (Lammens & Hoogenboezem 1991). At each step the choice is probably determined by some optimality principle in which the energetic constraints are most important (Pyke 1984), although also the presence of predators may also exert an influence (Werner & Hall 1988). In the present study we are mainly interested in the second decision, that is, the switch between particulate- and filter-feeding of zooplanktivorous bream.

The switchover from particulate-feeding to filter-feeding has been observed in several other zooplanktivorous fish species (O'Connell 1972, Jansen 1976, Holanov & Tash 1978, Crowder & Binkowski 1983, Crowder 1985, Gibson & Ezzi 1985, Lazzaro 1987, Ehlinger 1989, Sibbing 1991) and was found to be determined by fish-size, density and size distribution of prey, and light conditions.

In this paper we develop a model to predict the switchover from particulate- to filter-feeding in bream, using buccal volume, swimming speed and inter-prey distance as the most important variables. The model also describes maximum feeding rates (snap frequencies) in ideal conditions, that is, when vision and prey-handling are not limiting and when preys consist of only one species with a little variation in size.

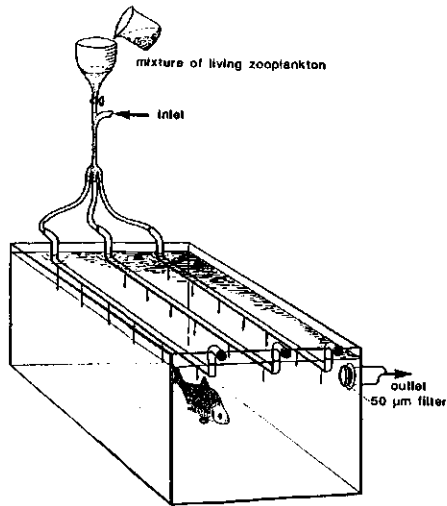

Fig. 1. Aquarium setup. Zooplankton is added to the tank via three PVC tubes through 2 mm holes. The prey density can be increased to a known level by adding zooplankton through the funnel; a continuous water current prevents conditioning of the fish to the added zooplankton.

Material and methods

Snap frequency

Feeding experiments were performed with six bream (7.5, 10.4; 12.5; 15; 24; 29.5 cm standard length (S.L.) obtained from Tjeukemeer, a shallow eutrophic lake in the North of The Netherlands. Because social interactions may influence the feeding behaviour in the experiments, only one fish was used per trial. Prior to the experiments, the fishes were kept in the laboratory for at least one month and before the experiment started the fish had been starved for 24-28 hours. The zooplankton density was zero when the experiment started and was raised every 2 or 4 minutes by adding known amounts of zooplankton using perforated plastic tubes (2 mm holes), to ensure a uniform distribution of zooplankton (Fig. 1); this was repeated 15-30 times. A continuous water flow of water through the system assured that the fish were not conditioned to the addition of zooplankton. A 50 μm plankton filter prevented the escape of prey through the outlet. For small fish (7.5-12.5 cm standard length), an aquarium of 25x25x10 cm was used, for

bream ≥ 15 cm an aquarium of 70x30x48 cm was used. The entire setup was surrounded by black plastic to reduce external disturbance of the fish during the experiment. Zooplankton was obtained from lakes and ponds and consisted predominantly of D. hyalina (mean length 1.14 mm) and D. pulex (mean length 1.29 mm). The density of zooplankton was corrected for feeding losses, which amounted to 10-20% at the beginning of the experiments in the small aquaria but less than 5% in the 100 l tanks.

Apart from the switching experiments in which the zooplankton density was raised, additional experiments were carried out in order to determine the effect of satiation and light on feeding mode and snap frequency (SF). Satiation was tested in an 8 hour experiment with a constant prey density of 300-400 l⁻¹ D. hyalina (mean length 1.22 mm) and a 24 cm bream. Snap frequency (SF) was determined during the whole period. To study the influence of light, the decrease of zooplankton was determined when a density of approximately 300 l⁻¹ was offered to three small bream (11-12 cm) or to one 29.5 cm bream in complete darkness. At the beginning and the end of the experiment (2 hours) the zooplankton density was determined by taking 0.5 litre samples using a perspex tube. The zooplankton was counted and measured.

Video recordings, with time registration, were used to analyze the number of snaps in relation to the zooplankton density and swimming speed of foraging bream. Time and distance were measured, when a fish swam parallel and close to the front window of the aquarium. This was necessary in order to reduce projection errors. We used relatively small aquaria to facilitate focussing on the mouth of the fish and the recording of separate snaps. Consequently the speed was measured over short distances (20-50 cm) and short periods (3-10, occasionally 25 seconds).

Buccal volumes

Buccal volume was measured according to the ellipse - method used by Drost & van den Boogaart (1986): simultaneous dorsoventral cine-recordings were made of four foraging bream (8.0, 23.3, 28.5 and 33.8 cm S.L.). Differences between maximal adduction and abduction of opercula were measured using enlarged film frames. Maximal adduction is measured using the last film frame prior to the snap, when no head expansion occurred. For maximal abduction the last film frame before the opening of the

opercula was used. The difference between these volume changes is assumed to be the volume of water intake during the snap.

The fish were trained for several weeks to feed under light conditions generated by six 500 W lamps, necessary for high speed filming. A Teledyne D.B.M. 54 camera, with Angenieux zoom obj. 10x12A, was used at film speeds of 48, 100 or 200 frames.s⁻¹, on Kodak Double X negative film (200 ASA).

Development of the model

The snap frequency of particulate-feeders is assumed to be determined by the encounter rate of the zooplankton, and thus predominantly determined by swimming speed and zooplankton density, when handling time and visibility are not limiting. However, when each random snap contains at least one item of prey, the fish is assumed to switch to filter-feeding with a maximal snapping frequency which will be constant when handling is not limiting.

Particulate-feeding: The model assumes that the encounter rate is largely determined by the average distance between preys animals and by the swimming speed of the fish. Snap frequency can be predicted if prey are visible and randomly distributed, and if the fish finds the optimal swimming route between prey animals, snapping at every non-evasive prey encountered.

The mean inter-prey distance (cm) is calculated from the zooplankton density (d in N.l⁻¹). The average volume around each prey is considered to be a cube with a side of A cm:

$$A = \sqrt[3]{1000 * d^{-1}} \text{ ml}$$

Each cube is surrounded by 26 similar cubes and therefore the average inter-prey distance D is

$$D = (6A + 8A\sqrt{3} + 12A\sqrt{2}) * (26^{-1}) \quad (\text{cm}).$$

Swimming from prey to prey at a mean speed of V cm s⁻¹ the fish will encounter V*D⁻¹ prey items per second. If every encountered prey is ingested, then:

$$\text{mean snap frequency} = V * D^{-1} \quad (\text{snaps.s}^{-1}).$$

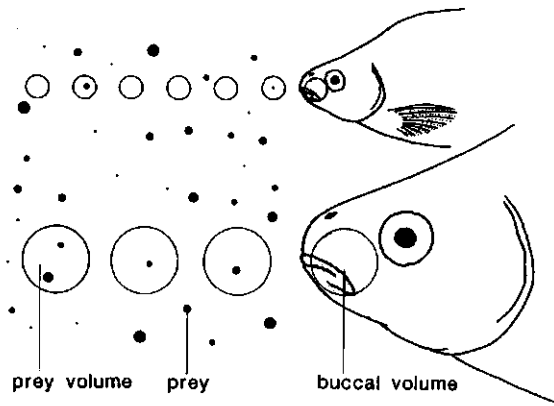

Fig. 2. Relation between buccal volume (cross-hatched circle), volume of water processed (open circle) and possible feeding mode. The buccal volume of small fish (top) is too small for them to engulf one prey in each random snap and therefore particulate-feeding will be most likely. Large bream (bottom) can ingest at least one prey per random snap and filter-feeding is most likely.

Filter-feeding: It is assumed that if each random snap is successful, that is, when the average volume surrounding each prey is equal to or smaller than the buccal volume, the snap frequency will be maximal (Fig. 2). When the zooplankton density is much higher than 1 per buccal volume the time needed for intra-oral handling of the prey may increase as well, slowing down the actual snap frequency.

Results

Observed snap frequencies

Maximal snap frequencies (SF) varied from 0.5 s⁻¹ in 7.5 cm bream up to 2 s⁻¹ in 24 cm bream (Fig. 3). In the small length classes SF increased in proportion to zooplankton density, whereas in the large length classes maximum SF was reached at a zooplankton density < 100 l⁻¹ and remained constant or gradually decreasing thereafter (Fig. 3). In large bream the variation in SF at zooplankton densities > 50 l⁻¹ was lower than in the small bream. When foraging, the smaller fish swam at relatively low speeds of about 1-2 cm.s⁻¹; they frequently stopped feeding and rested at the bottom of the tank or displayed bursts of activity. The larger fish swam at 5-7 cm.s⁻¹ and in a much more regular manner.

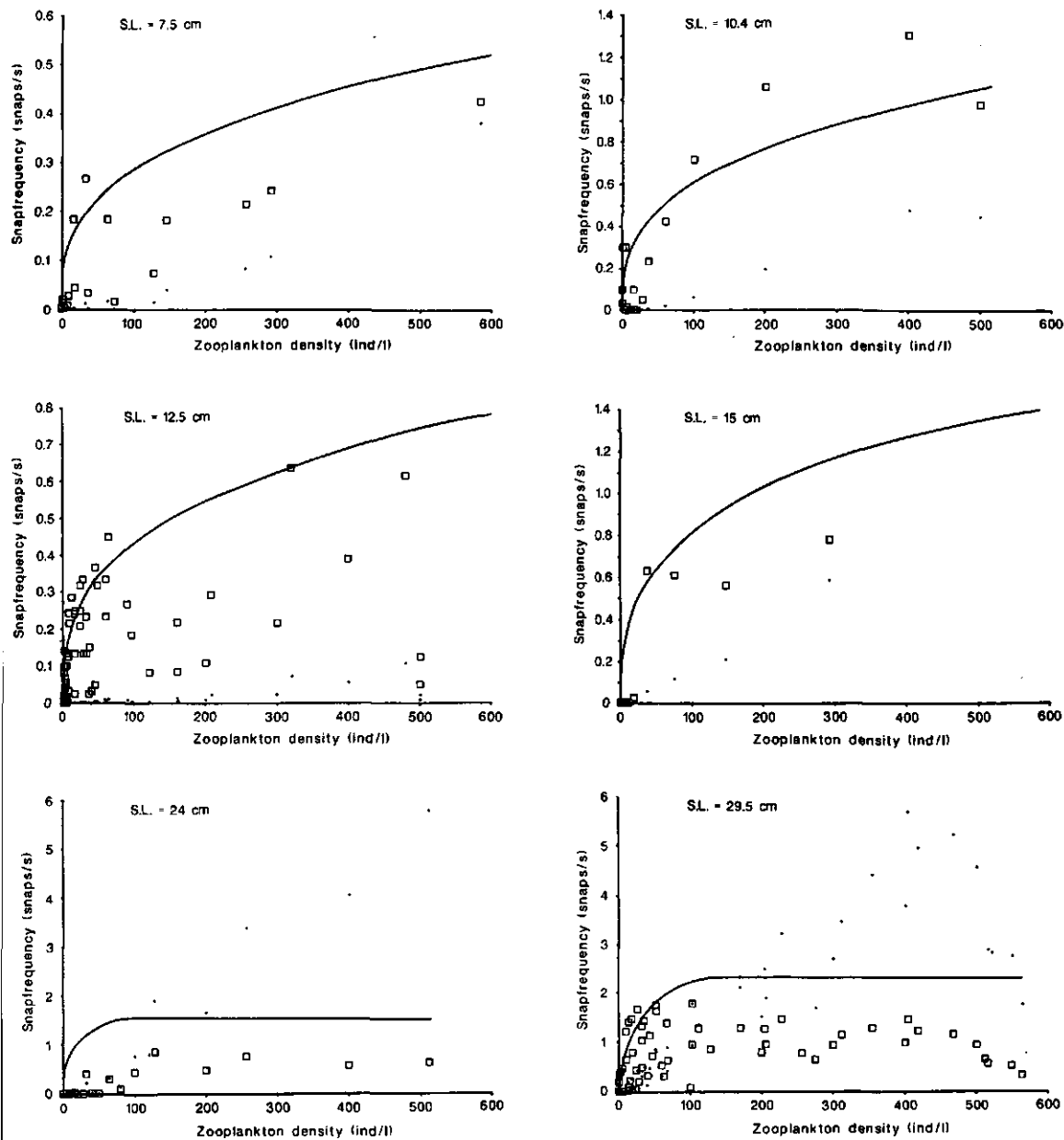

Fig. 3. Observed (open squares) and predicted snap frequencies (line) of six size-classes of bream (S.L. = standard length), at different *Daphnia* densities. Also indicated is the calculated number of prey items caught (dots) assuming strictly random snaps. The plateau of the curve in E and F indicates filter-feeding, with density independent snapping rate.

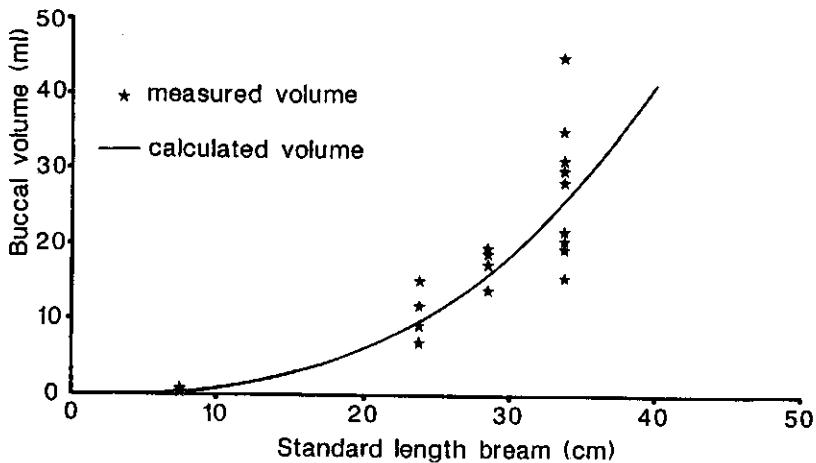

Fig. 4. Buccal volumes as measured during feeding in several size-classes of bream (*), and calculated (-) for all bream < 40 cm S.L.

Only the larger bream (24 and 29.5 cm) had a buccal volume sufficient large (9.5-16 ml, Fig. 4) to catch preys with random snaps at zooplankton densities $\geq 100 \text{ l}^{-1}$, and were usually filter-feeding. Particulate-feeding in large bream, was observed only when large conspicuous *Daphnia pulex* were present at low densities. However, the buccal volume of the smaller bream (0.3-2 ml, Fig. 4) allowed filtering only at densities $\geq 500 \text{ l}^{-1}$. Due to the more irregular feeding behaviour of small bream it was often difficult to observe which feeding mode was used. Usually, particulate-feeding fish make small upward movements with the head, whereas filter-feeding fish do not.

In the 8 hour experiment, the 24 cm bream foraged at a high and constant SF ($1.27 \pm 0.33 \text{ snap.s}^{-1}$; $n=21$ observations) for 7 hours. This value was not significantly different from the values found in the switching experiment for 24 cm bream at zooplankton densities of $300\text{-}400 \cdot \text{l}^{-1}$. (Fig. 3E). Thereafter its feeding rate dropped distinctly ($0.46 \pm 0.23 \text{ snap.s}^{-1}$ $n=6$) and the fish seemed satiated.

In complete darkness large bream (29.5 cm) reduced the zooplankton density from 262 to $158 \cdot \text{l}^{-1}$ in two hours in a 100 l tank (Fig. 5B), whereas three small bream (mean length 11.7 cm), under identical conditions, were not as efficient (Fig. 5A).

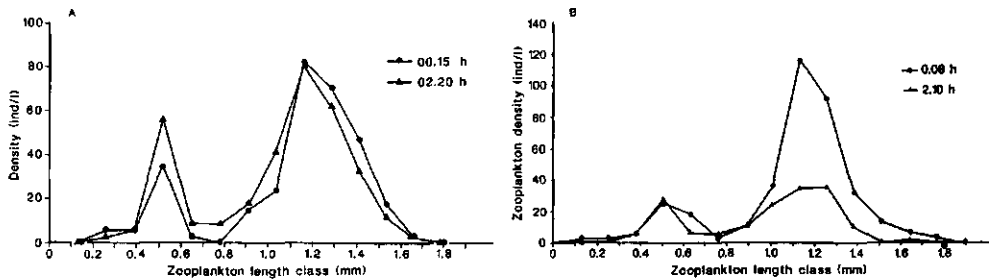

Fig. 5. Size distribution and density of zooplankton at the beginning and end of a 2 hour feeding experiment in total darkness for small (A) and large (B) bream.

Predicted snap frequencies

The average distance between the preys objects, the swimming speed, and the buccal volume of the fish were the most important variables of the model, whereas other possible variables were kept constant. The model predicted that large (24 and 29.5 cm) bream would switch to filter-feeding at ca. 100 and 60 zooplankters.l⁻¹, beyond which density they would maintain a constant or even decreasing SF, whereas smaller bream would not switch at all. The general shape of the model prediction predictions corresponded quite well with the observed values, but the predicted SF was almost two twice that actually observed (Fig. 3). The SF of the filter-feeding mode was derived from the maximum SF of the particulate-feeding mode. When the distance between the prey objects is so small that only handling time but not swimming speed is limiting, SF will remain constant or decrease. This was confirmed by the observed values. It seemed, however, that in large bream particulate-feeding was restricted only restricted to very low densities (24 cm bream) or it was not employed at all (29.5 cm). For the small bream the model predicted filter-feeding at zooplankton densities > 500 l⁻¹, the feeding experiments giving no evidence for filter-feeding at lower zooplankton densities. The model predictions corresponded to the maximum SF observed. Particularly the 7.5 cm bream showed large deviations at high zooplankton densities.

Bream of 11.7 cm S.L. did not feed in darkness, whereas 29.5 cm bream did (Fig. 5b). If the small bream were able to forage as particulate-feeders their SF would have

been ca. $1 \cdot s^{-1}$, corresponding to $7200 \cdot 3$ snaps in 2 hours and a decrease of zooplankton density by about $216 \cdot l^{-1}$. With the filter-feeding mode, 3 random snaps were needed for 1 prey which would have led to a decrease of $72 \cdot l^{-1}$ with the same SF, and 142 prey at the theoretically derived SF. Large bream did forage successfully in darkness, with a somewhat higher SF than was found in the switching experiment.

Discussion

Bream are able to feed on zooplankton during their whole lifespan (5 mm to 50 cm). Selectivity and feeding mode change in relation to the size of the fish and the density and size composition of the zooplankton (Lammens 1985, Lammens et al. 1987). Eutrophication in Dutch inland waters has stimulated the development of zooplankton up to densities of several hundreds per litre and has made zooplanktivorous feeding important for the formerly benthivorous fish (Loffler 1984, Lammens 1986). The branchial sieve plays an important part in the filter-feeding of larger bream (Hoogenboezem et al. 1990, Hoogenboezem et al. 1991). We have tried to model the switch-over from particulate- to filter-feeding and to determine the feeding intensity in relation to fish size and zooplankton density. Our feeding model differs from other feeding models as it describes two alternative feeding modes and the intensity of feeding, taking into account the size of the fish; however, it ignores feeding selectivity, which is the most important part of most feeding models (Werner & Hall 1974, Eggers 1977, O'Brien et al. 1976, Confer & Blades 1975, Wright & O'Brien 1984).

An important variable in our model is the volume of the buccal cavity. Most fish have to suck in some water surrounding the prey and this amount of water corresponds to, or is somewhat larger than, the volume created by head expansion (Van Leeuwen 1984, Drost & van den Boogaart 1986). Our hypothesis was that if the average volume of water surrounding an one individual prey is less than the buccal volume created by head expansion, the most profitable feeding mode will be by random snaps. At a density of $1 \cdot l^{-1}$ a 15 cm bream, in order to catch one prey object, can choose between 50 random snaps as a filter-feeder or 1 as a particulate-feeder to catch one prey. In this case the choice is quite easy, however, with increasing density at some point it will become more profitable to filter-feed at some point to begin filter-feeding. In our model we used an

arbitrary switching point of 1 prey per 1 snap, because we ignored the costs of searching at these high zooplankton densities. This proportion may be 1 to 2 or 1 to 3, if the costs for searching are higher than expected or if the costs for snapping are low. However, for bream exceeding 20 cm the prey is relatively so small that possibly the fish has problems locating it. The 29.5 cm bream did not or only sporadically, feed at low densities (Fig. 3F), although it ought to be rewarding to be a particulate-feeder under these conditions. The 24 cm bream showed approached its maximum SF at a zooplankton density of ca. 30 l^{-1} , which means that in the filter-feeding mode it takes 3 snaps for one prey. It is possible that for these fish particulate-feeding on small particles creates more problems than filter-feeding so that they prefer to do 3 blind snaps for 1 prey, instead of 1 'particulate' snap.

Although we realised that prey handling might be a limiting factor we could not quantify it. The handling of the prey occurs during 'closed protrusion movements' when the prey collected in the branchial sieve is detached and swallowed (Sibbing 1988). The closed protrusion movements are hard to quantify as they are difficult to distinguish from normal feeding movements when the mouth is opened and the upper jaw protruded. During benthic feeding these closed protrusion movements are clearly visible and occupy a large part of the foraging time (Lammens et al. 1987). Our ignoring of the handling time was probably largely responsible for the exaggerated model predictions. Another point related to the buccal cavity is that the calculated amount of water sucked in is a minimal estimate and that the real value may be higher because some water can flow through the buccal cavity when mouth and opercula are still open, especially during swimming (Muller & Osse 1984). In foraging trout the amount of water passing the mouth cavity in each strike far exceeded the volume of the buccal cavity (Van Leeuwen 1984). This implies that the real amount of water moved is probably higher and therefore filter-feeding can start at a lower density, than predicted from the calculated buccal volume.

The model also predicted a higher SF for the particulate-feeding mode than that observed. The model assumed a more or less ideal fish which sees all the prey objects, forages continuously, and is not limited by satiation or resting pauses. We assumed that swimming speed was constant during foraging and also that the swimming speed was not related to the zooplankton density or other factors. However, a fish does not swim from

prey to prey but follows a more or less straight line, so that the inter-prey distance experienced by the fish will be greater than the actual distance. At these high zooplankton densities it is probably much more profitable to swim in a straight line and to snap any prey encountered than to change direction continuously in order to take the shortest distance between preys items. At densities from 10 to 500 l⁻¹ the distance between preys items varies from 5 to 0.5 cm, which is much less than the length of the fish. As it seems almost impossible to determine the real encounter rate we therefore assumed an ideal fish finding an ideal swimming route. The swimming speed of *D. hyalina* and *D. pulex* is negligible compared to that of fish. Drenner et al. (1978) showed that cladocerans, contrary to copepods and *Chaoborus* larvae, do not have strong evasive abilities. Thus our model, does not take in account evasive behaviour of the prey, can only be used to predict the interactions between fish and cladocerans.

The main variables of our model allow good qualitative prediction of the switching behaviour in relation to the size of the fish and the density of the food organisms. The model is certainly not perfect, some variables, such as handling time, the actual distance between prey, and the real amount of water passing the buccal cavity per snap, have been ignored. By comparing observations with predicted SF we became more aware of the possible importance of the variables. If it were possible to determine the real amount of water per snap, the switching point could be estimated more accurately, and if it were possible to estimate the 'real' distance between prey the prediction of the number of snaps would also be more accurate.

Acknowledgements

We thank Koos Vijverberg, Nand Sibbing, Ramesh Gulati, Onno van Tongeren and Wolfgang Wieser for their critical remarks on the manuscript. We are also due to Peter McGillavry and Bert van den Bergh for their assistance during the feeding experiments and to Jos van den Boogaart and Karel Boekhorst, who prepared the figures. The investigation was supported by the Foundation for Fundamental Biological Research (BION), subsidized by The Netherlands Organization for Scientific Research (NWO), project 811-437-241B.

References cited

- Confer, J.L. & P.I. Blades. 1975. Omnivorous zooplankton and planktivorous fish. *Limnol. Oceanogr.* 20: 571-579.
- Crowder, L.B. & F.P. Binkowski. 1983. Foraging behaviours and the interaction of alewife, *Alosa pseudoharengus* and bloater, *Coregonus hoyi*. *Env. Biol. Fish.* 8: 105-113.
- Crowder, L.B. 1985. Optimal foraging and feeding mode shifts in fishes. *Env. Biol. Fish.* 12: 57-62.
- Drenner, R.W., J.R. Strickler & W.J. O'Brien. 1978. Capture probability: the role of zooplankton escape in the selective feeding of zooplanktivorous fish. *J. Fish. Res. Board. Can.* 35: 1370-1373.
- Drost, M.R & J.G.M. van den Boogaart. 1986. A simple method for measuring the changing volume of small biological objects, illustrated by studies of suction feeding by fish larvae and of shrinkage due to histological fixation. *J. Zool., Lond. (A)* 209: 239-249.
- Eggers, D.M. 1977. The nature of prey selection by planktivorous fish. *Ecology* 58: 46-59.
- Ehlinger, T.J. 1989. Foraging modes switches in the golden shiner (*Notemigonus crysoleucas*). *Can. J. Fish. Aquat. Sci.* 46: 1250-1254.
- Gibson, R.N. & I.A. Ezzi. 1985. Effect of particle concentration on filter- and particulate-feeding in herring *Clupea harengus*. *Marine Biology* 88, 109-116.
- Holanov, S.H. & J.C. Tash. 1978. Particulate- and filter-feeding in threadfin shad, *Dorosoma petense*, at different light intensities. *J. Fish Biol.* 13: 619-625.
- Hoogenboezem, W., F.A. Sibbing, J.W.M. Osse, J.G.M. van den Boogaart, E.H.R.R. Lammens & A. Terlouw. 1990. X-ray measurements of gill-arch movements in filter-feeding bream, *Abramis brama* (Cyprinidae). *J. Fish Biol.* 36: 47-58.
- Hoogenboezem, W., J.G.M. van den Boogaart, F.A. Sibbing, E.H.R.R. Lammens, A. Terlouw & J.W.M. Osse. 1991. A new model of particle retention and branchial sieve adjustment in filter-feeding bream (*Abramis brama* (L.) Cyprinidae). *Can J. Fish. Aquat. Sci.* 48: 7-18.
- Jansen, J. 1976. Feeding modes and prey selection in alewife (*Alosa pseudoharengus*). *J. Fish. Res. Board. Can.* 33:1972-1975.
- Lammens, E.H.R.R. 1985. A test of a model for planktivorous filter-feeding by bream, *Abramis brama*. *Env. Biol. fish.* 13: 288-296.
- Lammens, E.H.R.R. 1986. Interactions between fishes and the structure of fish communities in Dutch shallow, eutrophic lakes. Thesis Agricultural University, Wageningen, 100 pp.
- Lammens, E.H.R.R. & W. Hoogenboezem, 1991. Diets and feeding behaviour. In I.J. Winfield & J. Nelson (eds). *Cyprinid fishes: systematics, biology and exploitation*. Chapman & Hall., pp 253-376.
- Lammens, E.H.R.R., J. Geursen & P.J. McGillavry. 1987. Diet shifts, feeding efficiency and coexistence of bream (*Abramis brama*), roach (*Rutilus rutilus*), and white bream (*Blicca bjoerkna*) in hypertrophic lakes. *Proc. V. Cong. Eur. Ichthyol.* 153-162.

- Lazzaro, X. 1987. A review of planktivorous fishes: their evolution, feeding behaviours, selectivities and impacts. *Hydrobiologia* 146: 97-167.
- Leeuwen, J.L. van 1984. A quantitative study of flow in prey capture by rainbow trout Salmo gairdneri, with general considerations of the actinopterygian feeding mechanism. *Trans Zool. Soc., Lond.* 37: 171-227.
- Loffler, H. 1984. Zur Ökologie des Brachsen (Abramis brama (L.)) im Bodensee. *Schweiz. Z. Hydrol.* 46(1) 147-162.
- Muller, M. & J.W.M. Osse. 1984. Hydrodynamics of suction feeding in fish. *Trans. Zool. Soc. Lond.* 37: 51-135.
- O'Brien, W.J., N.A. Slade, and G.L. Vinyard. 1976. Apparent size as the determinant of prey selection by bluegill sunfish (Lepomis macrochirus). *Ecology* 57: 1304-1310.
- O'Connell, C.P. 1972. The interrelation of biting and filtering in the feeding activity of the northern anchovy (Engraulis mordax). *J. Fish. Res. Bd. Canada* 29: 285-293.
- Pyke, G.H. 1984. Optimal foraging theory: a critical review. *Ann. Rev. Ecol. Syst.* 15: 523-75.
- Sibbing, F. A. 1988. Specializations and limitations in the utilization of food resources by the carp, Cyprinus carpio a study of oral processing. *Env. Biol. Fishes* 22, 161-178.
- Sibbing, F.A. 1991. Food capture and oral processing. In I.J. Winfield & J. Nelson (eds). *Cyprinid fishes: systematics, biology and exploitation*. Chapman & Hall., pp 377-412.
- Werner, E.E., and D.J. Hall. 1974. Optimal foraging and the size selection of prey the bluegill sunfish (Lepomis macrochirus). *Ecology* 55: 1042-1052.
- Werner, E. E. and D. J. Hall. 1988. Ontogenetic habitat shifts in blue-gill: the foraging rate - predation risk trade-off. *Ecology* 69: 1352-1366.
- Wright, D.I., and W.J. O'Brien. 1984. The development and field test of a tactical model of the planktivorous feeding of white crappie (Pomoxis annularis). *Ecological Monographs* 54: 65-98.

PREY-SIZE SELECTIVITY AND SIEVE ADJUSTMENT IN FILTER-FEEDING BREAM (Abramis brama (L.), Cyprinidae)

Wim Hoogenboezem^{***}, Eddy H.R.R. Lammens^{*}, Peter J. MacGillavry^{*} and Ferdinand A. Sibbing^{**}.

Abstract

Sieve adjustment in filter-feeding bream (Abramis brama) was studied in feeding experiments using bream measuring ca 20 and 30 cm in standard length. The size-selective feeding observed in experiments was compared with predicted selectivity curves, derived from the channel width, total filtered volume and the retention probability of prey in the reduced or unreduced channels. The relation between retention probability of Daphnia of known length and mesh-size, was determined empirically in sieving experiments, using commercial sieves. The results obtained with 20 cm fish demonstrated that bream is able to adjust its filter in two distinct mesh-sizes. The relation between filter adjustment and zooplankton availability was not clear in all cases. The prey selectivity of large bream (> 30 cm) was in close accordance with the model prediction for filter-feeding with reduced channels.

Introduction

Micro-crustaceans form an important food resource for bream (Abramis brama) in eutrophic lakes. At sufficiently high zooplankton densities, all size classes of bream feed on zooplankton, although selectivity differs between length classes (Lammens, 1985; Lammens et al. 1987).

^{*} Limnological Institute Vijverhof Laboratory,
Rijksstraatweg 6, 3631 AC Nieuwersluis, The Netherlands

^{**} Agricultural University, Department of Experimental Animal Morphology and Cell Biology, Marijke weg 40, 6709 PG Wageningen, The Netherlands

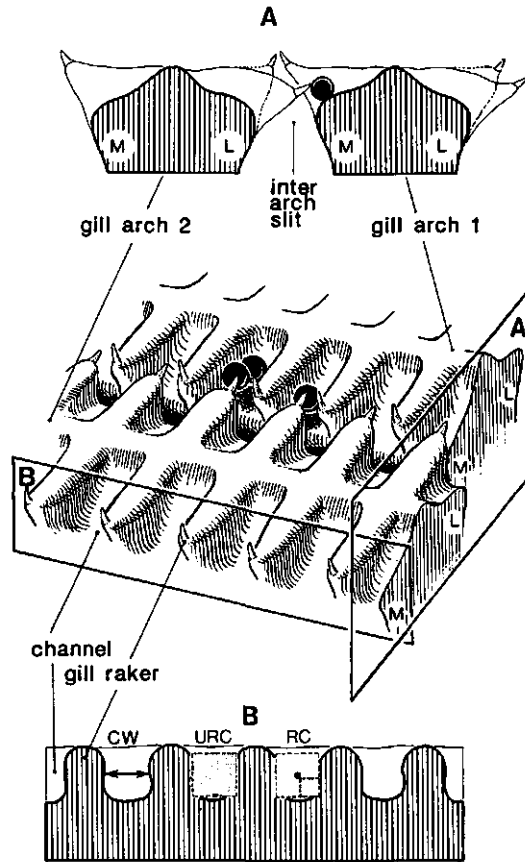

Fig. 1. Scheme of a part of two gill-arches of the branchial sieve of bream. Note the channels and the site where small (0.5-1.0 mm) particles (black spheres) are retained. Plane A: cross section through two adjacent gill-arches, indicating the lateral movable raker in rest position (dotted line) and the raker inserted into the adjacent channel (solid line). Plane B: a cross section through the channels: channel width (CW) was measured as indicated (arrow). URC = the mesh-size of the unreduced channel compared with the mesh of the commercial sieve. RC = the reduced mesh-size of the channel compared with a smaller mesh of the commercial sieve, the inserted raker-tip is indicated as a black dot.

Filter-feeding bream sieves randomly engulfed water, the selectivity is determined mainly by the mesh-size of the branchial sieve (Lammens & Hoogenboezem, 1991). Thus the occurrence of sieve adjustment in bream can be tested in filter-feeding specimens. In small bream or at low density selectivity may be influenced by the visual orientated particulate feeding mode (Jansen, 1976; Lammens, 1985; Hoogenboezem et al.

1991^b Sibbing, 1991). Some prey-species, such as copepods and *Chaoborus*-larvae, may influence selectivity by a strong evasive behaviour, while cladocerans do not escape from approaching predators (Drenner et al., 1978).

The mechanism of particle retention and the mesh-size of the branchial sieve in filter-feeding bream has been studied in detail. X-ray studies on the gill-arch movements of filter-feeding bream (Hoogenboezem et al., 1990) showed that a simple retention mechanism with interdigitating gill-rakers (cf. Sibbing, 1991) is not likely. A detailed analysis of the branchial sieve morphology indicated that particles are retained in channels on the upper surface of the branchial arches. Food particles were indeed found in these channels and X-ray movies showed the expected paths of particles during filter-feeding (Hoogenboezem et al. 1991^a).

Tiny muscles connected to the lateral gill-rakers will reduce the mesh-size by manoeuvring the raker-tip into the channel of the adjacent arch (Fig. 1). This mechanism enables bream to adjust its filter mesh to two sizes: the larger mesh-size represented by the unreduced channel (URC) and the smaller by a reduced channel (RC; Fig. 1), which is estimated to be about half the channel width. Evidence for actual sieve adjustment was gained from feeding experiments, which demonstrated that bream adjusted its mesh-size according to density and size distribution of the zooplankton (Hoogenboezem et al., 1991^b).

In this study the mechanism of sieve adjustment in bream can be tested quantitatively by comparing predicted selectivity curves, based upon the channel-model with experimental selectivity curves. The latter is obtained from feeding experiments conducted under filter-feeding conditions, with a non-evasive prey-type. Considerable deviations from the model predictions are expected if the fish uses the particulate-feeding mode and due to visual selection a disproportional number of large prey will be ingested.

Selectivity curves, predicted from the model, are based on the number and size distribution of the prey-items at the start of the experiment but also the mesh-size of the channels (URC or RC) and the buccal volume and snap-frequency of the experimental fish, are important. The empirical retention probability of each size-class of the prey in the branchial sieve was also used for the calculation.

Material and Methods

Sieving experiments and prediction of retention probability

The retention probability of cladocerans in relation to mesh-size was determined with commercial sieves (diameter 10 cm). One litre live zooplankton was poured over a sieve with known mesh-size (0.210 mm, 0.285 mm, 0.430 mm or 0.750 mm).

Thereafter the sieve was washed with 1 litre plankton free water. The filtrate was collected on a 0.060 mm sieve. Length of zooplankton was determined from both fractions. Cladoceran lengths were measured to the nearest 0.02 mm, using an ocular micrometer and were arranged in length classes of 0.11 mm.

The retention probability of each *Daphnia* length-class in the commercial sieve (P_{cs}) is calculated as the ratio between the number of daphnids retained/total number of daphnids. At isometric growth the P_{cs} will be determined by the proportion between *Daphnia*-size and mesh and therefore the ratio *Daphnia*-length/mesh-size (L/M -ratio) is assumed to determine the P_{cs} . The results of the sieve experiments are used to determine the L/M -ratio.

The mesh used in the sieving experiments has the form of a square while the channels in bream are rounded in section (Fig. 1). To determine the retention probability of a certain prey in the branchial sieve, the unreduced channel width (URC) was used as M in the L/M ratio (Fig. 1). The calculation of retention probability in reduced channels (RC) was corrected for the width of the inserted gill-raker tip (Fig. 1).

Channel diameter measurements

Channel diameters were measured in a series of 30 bream, ranging from 3 to 43 cm S.L. (standard length), caught in Tjeukemeer, a shallow, eutrophic lake in the north of The Netherlands. The captured bream, which were immediately preserved in formalin (10%), were used in the measurements after ca 14 days. The branchial sieves were dissected from the fish and measured, Van den Berg et al. (1991) showed shrinkage due to fixation is only ca 4%. In each gill-arch the mean width of the channel was measured in five channels, in the central area of the arch (Fig. 1).

Feeding experiments: the observed selectivity

Bream were caught in Tjeukemeer and acclimated in aquaria at 18 °C, for at least 6 weeks before the feeding experiments started. During this period bream of various length (18.0; 20.0; 21.6;21.8; 22.1; 23.5; 29.5; 30.0; 34.3; 34.5 cm, S.L.) were fed on live zooplankton. The experiments were conducted in aquaria (180 x 60 x 60 cm for bream 29.5 - 34.5 cm or 90 x 60 x 60 cm, for bream < 30 cm) each containing one bream. Zooplankton was collected with a hoopnet (125 or 250 µm mesh-size) from the lake and transported in buckets to the laboratory. From the freshly collected zooplankton the injured daphnids were removed in about 30 minutes. These daphnids had usually air between their valves and did not swim normally but floated on the surface. Only vital zooplankton was added to the experimental tank, its density and size distribution were determined by taking 12 or 20 (in the larger tank) water samples of ca 200 ml with a perspex tube (5 cm diameter, 40 cm length) with a stopper. The samples were filtered through an 0.060 mm sieve and the zooplankton was preserved in 4% formalin. The volume of sampled water was measured in a calibrated cylinder to the nearest 5 ml. The length of zooplankton was measured to the nearest 0.02 mm, excluding caudal spine and helmet, using an ocular micrometer. The zooplankters were grouped per species in successive length classes of 0.11 mm. The sampling procedure was repeated after a foraging time of 2-4 hours. Several feeding trials were carried out in complete darkness, to determine whether visual effects influenced the observed selectivity.

The observed selectivity (P_{obs}) of the experimental fishes was calculated per size-class as the ratio between the number of zooplankters before and after the experiment

(equation 1):
$$P_{obs} = \frac{N_0 - N_t}{N_0} \quad \text{(equation 1)}$$

Estimation of feeding efficiency and filtered volume

The decrease of zooplankton in the experimental tank, depends on: the water volume, zooplankton density, buccal volume of the fish, snap frequency (Hoogenboezem et al. 1991^b), foraging time, and the size dependent retention probability of prey-items in the branchial sieve. A filter-feeding bream takes series of snaps, each snap represents a certain volume of water containing prey-items. During the experiment the number of prey

decreases exponentially, depending on the mentioned variables. The expected number of prey-items remaining after the experiment can be calculated for each size class by equation 2:

$$N_t = N_0 * e^{-((BV/AQ) * SF * RF * t)} \quad (\text{equation 2})$$

- N_0 = Number of prey present in the tank, at $t=0$
- N_t = Number of prey in the tank after t seconds
- BV = Buccal volume (L)
- AQ = Aquarium volume (L)
- SF = Snap frequency (snaps/s)
- RF = Retention probability of prey in channel
- t = Duration of the experiment (s)

Since exact data for the snap frequency (SF) over the total experimental period were not available, the SF was derived from the decrease of the largest prey items which are 100% retained ($RF=1$) in the branchial sieve (equation 3).

$$\frac{\ln(N_t/N_0)}{-(BV/AQ) * t} = SF \text{ (snap * s}^{-1}\text{)} \quad (\text{equation 3})$$

The mean calculated snap frequency for larger prey ($RF=1$) is applied in equation 2 to calculate the number of prey, of each size-class, that should remain at the end of the experiment.

Substitution of the mean SF and other variables into equation 2 reveals the number of prey left, for each size classe, after the experiment. The retention probability in the branchial sieve (RF) is calculated for both unreduced (URC) and reduced (RC) channels, for all trials separately.

Calculations were made to determine the expected selectivity (equation 1) for unreduced (P_{urc}) and reduced (P_{rc}) channels, using the expected numbers of prey at the end of the experiments. The mean observed selectivity, for each size class, of several experiments was plotted in one figure together with the selectivity curves calculated from the model.

Results

Experiments with commercial sieves

The retention probability for *Daphnia* sp. having a length > 2.5 times the mesh-size (bar mesh) of the sieve is 100% ($P_{cs}=1$). Specimens of the same length as the mesh width ($L/M=1$) were hardly retained ($P_{cs} < 0.15$). Between L/M -ratio's 1.0 and 2.5 the probability of retention sharply increases (Fig. 2). The measured retention ratio is more or less a sigmoid curve, the ascending part of the curve fits closely to a linear function (Fig. 2). The linear relation was used to calculate the retention probability of prey-items in the experiments, using the length of the cladoceran and the channel width as variables in the L/M ratio.

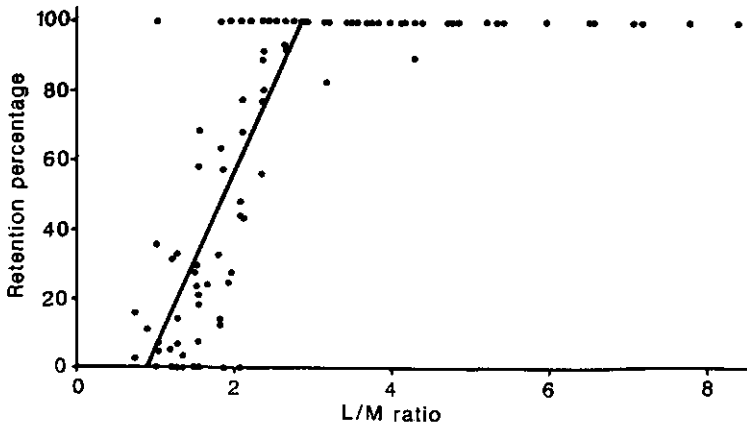

Fig. 2. Experimentally determined retention percentage (P_{cs}) of *Daphnia hyalina*, *D. cucullata* and *Ceriodaphnia pulchella*, plotted as a function of the ratio length/mesh-size (L/M). Linear regression over the (L/M) range 1 - 3.5 revealed an empirical retention function

$P_{cs} = 0.57*(L/M) - 0.55$, ($n = 89$; $R^2 = 0.70$), which was used in the model calculations.

Channel diameters

Based on the width of the inter-arch slits during feeding (Hoogenboezem et al. 1990), ca 90% of the water was estimated to flow through the first two slits. The slit between arch I and II is ca 31 mm long and 2.4 mm wide and represents ca 68% of the slit surface, at maximal abduction in a 31.5 cm bream. The slit between arches II and III is

slightly shorter (ca 30 mm) and distinctly less wide (0.86 mm) and is supposed to conduct only 22% of the water (Hoogenboezem et al. 1990; 1991). The widths of the medial channels in these slits are similar (1.26 and 1.28 mm resp., in a 31.0 cm bream).

In one experimental fish (31.0 cm S.L.) all channels in the left halve of the sieve were measured. Distinctly smaller channels were observed (arch I medial channels 0.64 mm; s.d. 0.19; n=7), especially in the area where the branchial arches (epi-branchial area) are connected to the skull. The channels in the central area are larger and more regular in width (arch I medial channel: 1.26 mm; s.d. 0.03; n=16). A decrease in channel width, central area, from the first arch towards the fourth arch (medial channel 0.70 mm; s.d. 0.16; n=10) was determined.

The channel width, measured in the central area of the gill-arch, in bream is linearly related to fish-size. A distinct linear relationship was observed (van den Berg et al. 1991) for the medial channels arch 1:

$$CW = (0.046 * S.L.) - 0.104 \quad (\text{S.L. in cm; } n=150; R^2 = 0.94).$$

In model calculations the calculated channel-width of the medial channels (arch I) was used, since ca 90% of the water will flow through slits with channels of this diameter.

Feeding experiments: the observed selectivity

The 18.0 - 23.5 cm bream was found to adjust its filter apparatus (Fig. 3A, 3B). In seven trials the density of cladocerans was as predicted for the reduced channel model and five experiments were closely to the unreduced channel model (URC). While two experiments were intermediate between the URC and RC model curves. Unfortunately the filter adjustment was not clearly related to the feeding conditions (Tab. 1).

For bream > 30 cm the retention curve derived from the model for particles in the unreduced channels is very low (Fig. 4), the largest prey items in the experiments have a retention probability of ca 0.2 in the URC model prediction. As expected all experiments using large bream (30.0 - 34.5 cm) indicate reduced channel foraging (Fig. 4). The mean P_{obs} fits the expected RC-curve very well. Some individual trials deviated from the RC-model curve, but the observed retention probability was still considerable higher than the URC-model curve.

Feeding experiments (21.8 cm S.L., n=2; 29.5 cm S.L., n=3) conducted in the dark generally show a pattern similar to the results obtained from experiments conducted in

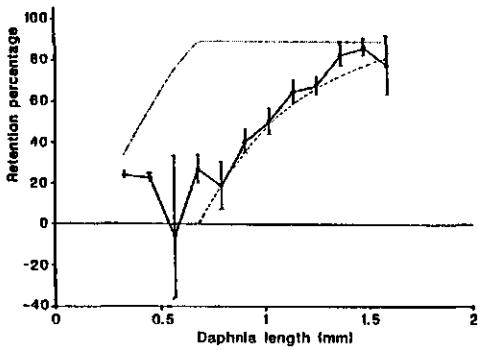

Fig. 3a

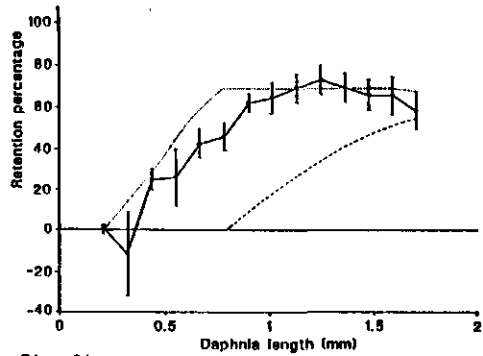

Fig. 3b

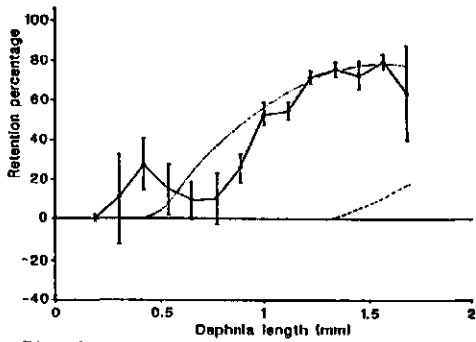

Fig. 4

density ind l ⁻¹	reduced chan.	unreduced chan.	inter- mediate
< 100	4	1	0
> 100	3	4	2

Tab. 1

Fig. 3A. Mean observed retention percentage (P_{obs}) \pm s.e. in 5 feeding-experiments of intermediate bream (18.0 - 23.5 cm S.L.), feeding on daphnids of different length classes, as a function of prey-length. The dotted line represents the curve predicted from the model for reduced (P_{RC}) and the dashed line represents the predicted curve for unreduced channels (P_{URC}). Note an observed retention (P_{obs}) similar as predicted from the model for unreduced channels.

Fig. 3B. Mean observed retention percentage (P_{obs}) \pm s.e. in 9 feeding-experiments of intermediate bream (18.0 - 23.5 cm S.L.), feeding on daphnids of different length classes, as a function of prey-length. The dotted line represents the curve predicted from the model for reduced (P_{RC}) and the dashed line represents the predicted curve for unreduced channels (P_{URC}). Note an observed retention similar as predicted from the model for reduced channels. This mean curve includes the two experiments which were intermediate between the model curves.

Fig. 4. Mean observed retention percentage (P_{obs}) \pm s.e. in 16 feeding-experiments of large bream (30.0 - 34.5 cm S.L.), feeding on daphnids of different length classes, as a function of prey-length. The dotted line represents the curve predicted from the model for reduced (P_{RC}) and the dashed line represents the predicted curve for unreduced channels (P_{URC}). Note an observed retention similar as predicted from the model for reduced channels.

Tab. 1. 14 feeding trials with 18.0 - 23.5 cm bream, the relation between food availability and sieve adjustment. At low density four bream were feeding with reduced and only one with unreduced channels. At high density four were feeding with unreduced and three with reduced channels, two trials showed an intermediate curve.

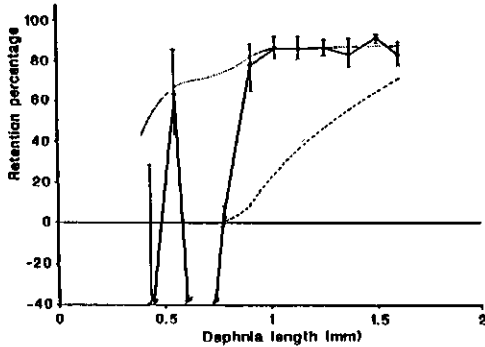

Fig. 5a

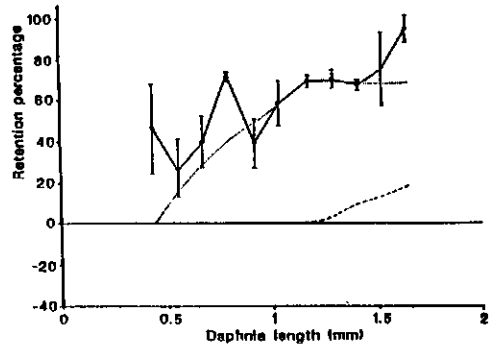

Fig. 5b

Fig. 5A. Mean observed retention percentage (P_{obs}) \pm s.e. in 2 feeding-experiments of intermediate bream (21.8 cm S.L.) conducted in complete darkness, feeding on daphnids of different length classes, as a function of prey-length. The dotted line represents the curve predicted from the model for reduced (P_{RC}) and the dashed line represents the predicted curve for unreduced channels (P_{URC}). Note an observed retention similar as predicted from the model for reduced channels.

Fig. 5B. Mean observed retention percentage (P_{obs}) \pm s.e. in 3 feeding-experiments of large bream (29.5 cm S.L.), conducted in complete darkness, feeding on daphnids of different length classes, as a function of prey-length. The dotted line represents the curve predicted from the model for reduced (P_{RC}) and the dashed line represents the predicted curve for unreduced channels (P_{URC}). Note an observed retention similar as predicted from the model for reduced channels.

light. The mean curve of observed P_{obs} closely fits the models prediction for reduced channels (Fig. 5A; 5B). The mean retention curve for the 29.5 cm fish was slightly higher than the predicted.

Discussion

The retention probability of particles in a sieve depends on at least three factors: a) the mesh-size and homogeneity of the sieve (Boyd, 1976; Wright, et al. , 1983; Drenner et al. 1984; Gibson, 1988); b) the size and shape of the particles (Wright, 1983; Gibson, 1988); and c) the orientation of the particle when approaching the mesh of the sieve.

The homogeneity of the sieve expressed as a cumulative frequency of different inter-raker distances, may serve as a retention probability curve (Boyd 1976). It assumes a proportional flow of water through every part of the sieve, but this is not necessarily the

case in bream. In the branchial sieve of bream the size distribution of the channels appeared to be related to the position on the arch. Only a few (6-8 per arch) distinctly smaller channels are placed in the upper (epi-branchial) part of each arch, they are partly or completely concealed by the large cushion-like palatal organ (cf. Sibbing & Uribe, 1985) and it is very improbable that a proportional part of the water will flow through these channels. The channels lying in the horizontal part of the branchial sieve show only minor variation in diameter and therefore a constant mesh-size, for each fish, was used in the model calculations. Moreover, the mesh-size was taken from an area where the major part of the water is filtered (medial channel arch I).

The orientation of approaching particles cannot be quantified, since it is impossible to know the orientation of each particle. Due to this uncertainty it is expected that a particle has a retention probability rather than a fixed value. Both Gibson (1988) and Wright et al. (1983) were unable to determine an appropriate measure of the prey items to estimate reliably the retention probability. In this study the empirically determined P_{∞} by means of the L/M-ratio appeared to be useful. From the present results the channel width, or reduced channel width, seems to be a suitable measure for the mesh-size of the branchial sieve.

Predictable value of the channel model

Intermediate bream (18.0 - 23.5 cm) was supposed to adjust its filter-apparatus, depending on the zooplankton density (Hoogenboezem et. al. 1991a). Bream of this size appeared to be able to adjust its filter according to the channel model. Several feeding trials showed URC-feeding and also distinct RC-feeding trails were observed. In two experiments, however, the position of observed retention curve is clearly between those of URC and RC model curves. The zooplankton depletion during the experiment may be responsible for this shift. The relation to availability of prey is not always conclusive for the sieve adjustment and remains provisional unpredictable. Also the fact that 20 cm bream does not always feed with reduced channels remains to be explained. Such a strategy would increase the number of retained prey-items per unit of time. Filtering with reduced channels may increase resistance of the sieve, demanding more energy; and feeding at high prey density may increase the handling time to an unfavourable level. As

bream envelopes the strained zooplankton in mucus in bream (Hoogenboezem & v.d. Boogaart, in prep.); the handling time may be limited by the mucus production.

Since channel width increases with body size, the channel width can become too wide for effective retention of cladocerans in large (>30 cm) bream. Bream of this size possess channels >1.2 mm, too large for URC-feeding, which was confirmed by the feeding experiments where all fishes fed with reduced channels. Consequently bream of 40 cm or larger is probably unable to feed on zooplankton efficiently. This may explain why in Tjeukemeer, where the density of large daphnids (>1.4 mm) is usually low (Vijverberg & Richter, 1982; Lammens et al 1985; Vijverberg et al. 1990) and alternative benthic prey is scarce, bream rarely exceeds 40 cm in length.

The retention probability in the branchial sieve of bream appeared to be reasonably predictable by calculations based on the channel model. The present results confirm the predictions from the channel model, but the mechanism that triggers the adjustment of filter is not yet clear. It is likely that detailed measurements of prey-size distribution in gut contents of bream, collected in the field, which have been foraging under more constant (known) food supply may give clues on the conditions for the different sieve adjustments in filter-feeding bream of intermediate size.

In conclusion; the combination of the functional morphology of the branchial sieve system supplied with aquarium experiments, has provided us with enough evidence for the hypothesis that the enormous expansion of the population size of bream in our eutrophic waters may be due to the efficient system of particle retention in bream.

Acknowledgements

We thank Jan W.M. Osse (Wageningen), Koos Vijverberg (Nieuwersluis) and Jos G.M. van den Boogaart (Wageningen) for their helpful suggestions to improve the manuscript. Jos G.M. van den Boogaart is acknowledged for preparing the figures. The investigation was supported by the Foundation for Fundamental Biological Research (BION), subsidized by the Netherlands Organization for Scientific Research (NWO Project 811-437-241B).

Literature

- van den Berg, C., F.A. Sibbing, J.W.M. Osse & W. Hoogenboezem. 1991. Structure, development and function of the branchial sieve of bream, Abramis brama, white bream, Blicca bjoerkna and roach, Rutilus rutilus. Environ. Biol. Fish. 000-000.
- Boyd, C.M., (1976). Selection of particle sizes by filter-feeding copepods: a plea for reason. Limn. & Oceanogr. 21:175-180
- Drenner, R.W., J.R. Strickler & W.J. O'Brien. 1978. Capture probability: the role of zooplankton escape in the selective feeding of zooplanktivorous fish. J. Fish. Res. Board. Can. 35: 1370-1373.
- Gibson, R.N. 1988. Development, morphometry and particle retention capability of the gill rakers in the herring, Clupea harengus L. J. Fish Biol. 32: 949-962.
- Hoogenboezem W., F.A. Sibbing, J.W.M. Osse, J.G.M. van den Boogaart, E.H.R.R. Lammens and A. Terlouw. 1990. X-ray measurements of gill-arch movements in filter feeding bream (Abramis brama, Cyprinidae). J. Fish Biol. 36: 47-58.
- Hoogenboezem, W., J.G.M. van den Boogaart, F.A. Sibbing, E.H.R.R. Lammens, A. terlouw & J.W.M. Osse. 1991^a. A new model of particle retention and branchial sieve adjustment in filter-feeding bream (Abramis brama (L.) Cyprinidae). Can J. Fish. Aquat. Sci. 48: 7-18.
- Hoogenboezem, W., E.H.R.R. Lammens, Y. van Vugt and J.W.M. Osse. 1991^b. A model for switching between particulate-feeding and filter-feeding in the common bream, Abramis brama. Environmental biology of fishes 000-000
- Hoogenboezem, W. & J.G.M. van den Boogaart (in prep.), The role of oro-pharyngeal mucus in filter-feeding bream (Abramis brama).
- Jansen, J. 1976. Feeding modes and prey selection in alewife (Alosa pseudoharengus). J. Fish. Res. Board. Can. 33: 1972-1975.
- Lammens, E.H.R.R. 1985. A test of a model for planktivorous filter-feeding bream Abramis brama. Env. Biol. Fish 13: 288-296.
- Lammens, E.H.H.R., H.W. de Nie & J. Vijverberg. 1985. Resource partitioning and nich shifts of bream (Abramis brama) and eel (Aguilla anguilla) mediated by predation of smelt (Osmerus eperlanus) on Daphnia hyalina. Can. J. Fish. Aquat. Sci. 42: 1342-1351.
- Lammens, E.H.R.R., J. Geursen and P.J. MacGillivray, (1987). Diet shifts, feeding efficiency and coexistence of bream (Abramis brama, roach (Rutilus rutilus) and white bream (Blicca bjoerkna) in hypertrophic lakes. Proc. Vth Congress Europ. Ichthyol. Stockholm 1985: 153-162.
- Lammens, E.H.R.R. and W. Hoogenboezem. 1991. Diets and feeding behaviour. in: Cyprinid fishes: systematics, biology and exploitation. Chapman & Hall., pp 253-376.
- Sibbing, F.A. & R. Uribe, 1985. Regional specialisations of the oropharyngeal wall and foodprocessing in the carp (Cyprinus carpio L.). Neth. J. Zool. 35:3 77-422.

- Sibbing, F.A. 1991. Food capture and oral processing. In: Cyprinid fishes: systematics, biology and exploitation. Chapman & Hall., pp 377-412.
- Vijverberg, J. & A.F. Richter 1982. Population dynamics and production of Daphnia hyalina Leydig and Daphnia cucullata Sars in Tjeukemeer. Hydrobiologia 95: 235-259.
- Vijverberg, J., M. Boersma, W.L.T. van Densen, W. Hoogenboezem, E.H.H.R. Lammens & W.M. Mooij. 1990. Seasonal variation in the interactions between piscivorous fish, planktivorous fish and zooplankton in a shallow eutrophic lake. Hydrobiologia 207: 279-286.
- Wright, D.I., O'Brien, W.J., and Luecke, C., 1983. A new estimate of zooplankton retention by gill rakers and its ecological significance. Tran. Am. Fish. Soc. 112: 638-646.

MUCUS IN FILTER-FEEDING OF BREAM (Abramis brama)

W. Hoogenboezem^{***} and J.G.M. van den Boogaart^{*}

Abstract

In a large number of freshly caught bream (Abramis brama) mucus boluses were found in their oro-pharyngeal cavity. This mucus appears to play an important role in aggregation and transport of food particles from the branchial sieve towards the esophagus. This contrasts with the traditional role of mucus in fish viz. the reduction of water flow resistance, protection of the underlying epithelium and retention. Mucus boluses containing up to 900 zooplankters have been isolated from the pharyngeal cavity of bream and from these the capacity and selectivity of the filtering system have been calculated. Using light microscopy and special staining methods we found different types of mucus cells in the oro-pharyngeal wall of bream, increasing in number from anterior to posterior. Based on our increasing knowledge of branchial sieving, we hypothesized the role of mucus for filter feeding in bream: small particles are retained mechanically in the branchial sieve, become enveloped in mucus and act as sticky particles. During recollection from the branchial sieve following closed protrusion, the sticky particles form a mucus bolus, which is stored posteriorly in the branchial chamber. After several of these cycles over a time span of several minutes the bolus is swallowed.

Introduction

Bream (Abramis brama), a common cyprinid in Dutch eutrophic waters, forages effectively on zooplankton during its entire lifespan (Lammens, 1985; Lammens et al.

^{*} Agricultural University, Dept. of Experimental Animal Morphology and Cell Biology, Marijkeweg 40, 6709 PG Wageningen, The Netherlands

^{**} Limnological Institute, Vijverhof Laboratory, Rijksstraatweg 6, 3631 AC Nieuwersluis, The Netherlands

1987; Lammens and Hoogenboezem, 1991). Relatively large specimens (up to 30 cm fork length F.L.) are able to retain even small cladocerans (>0.5 mm) in the channels of the branchial sieve (Hoogenboezem et al., 1990; 1991). Retained food particles have to be transported from the branchial sieve towards the esophagus. The particles may easily be lost through the large inter-arch slits (Hoogenboezem et al., 1990; Van den Berg et al., 1991), if nothing prevents this. The presence of zooplankton embedded in mucus in the oro-pharyngeal cavity of bream points to its importance in the processing of retained zooplankton. Therefore we describe in this study the types and distribution of mucus producing cells in the branchial sieve of bream, mechanisms of mucus release and the role of mucus in collecting and transport of captured particles from the branchial sieve system of bream.

In various ways mucus is involved in the biology of a wide variety of organisms (c.f. Sibbing and Uribe, 1985). It forms a barrier to foreign bodies and pathogens, to chemical or electrical gradients and it protects the underlying epithelium from mechanical damage. Also it might reduce friction and change boundary layers during locomotion and transport. Mucus also aids in entrapment and transport of particles e.g. in foodgathering of many invertebrates (i.e. bivalves, tunicates, cnidaria etc.). In tracheal systems of mammals, for example mucus is involved in particle entrapment.

The role and structure of mucus cells on the skin of fish has received considerable attention (references in: Sibbing and Uribe, 1985). The latter authors also describe the characteristics of oro-pharyngeal mucus. They noted distinct differences in size, shape, position and contents of mucus cells in the oral epithelium of carp (Cyprinus carpio), which all secrete acid mucus. A large sacciform type of mucus cell contains sulphomucines and a smaller pyriform cell type contains sialomucines. Sibbing and Uribe found that in carp (Cyprinus carpio) the sialomucine producing cells are found all over the oro-pharyngeal cavity. They predominate in the buccal cavity, playing a possible role in reducing water flow resistance and the boundary layer. They peak at the entrance of the pharyngeal cavity, where larger particles are trapped between the roof and the floor. Here they form a mechanical barrier to damages of the epithelium. The sulphomucine producing cells predominate in the posterior pharyngeal region, serving transport and aggregation into a sulphomucine mucus bolus of foodparticles just before swallowing.

However, the role of mucus in filterfeeding of fish is still obscure. Drenner et al. (1982) report the presence of mucus bound zooplankton in the gizzard shad (Dorosoma cepedianum) but no details on numbers or frequency of this observation are available. This early observation also lacks information on its possible role. Several other authors proposed mechanisms for particle retention by means of mucus (Greenwood, 1953; Matthes, 1963; Northcott and Beveridge, 1988; Beveridge et al., 1989). Sanderson et al. (1991) endoscopically observed small aggregations of food particles and mucus in blackfish (Orthodon microlepidotus) but it is not clear whether these aggregations were a result of a retention function of the mucus or performed a role in transporting the retained particles.

Materials and methods

Bream (Abramis brama) were collected by trawling (net, mesh-size 5.5 mm) from different lakes in Friesland in the north of the Netherlands. At the same time water samples were taken at different places in the lakes using a 5-L Friedinger sampler (c.f. Lammens et al., 1985) to estimate density and size distribution of the zooplankton in the different lakes. Bream were measured (fork length, F.L.), selected (40 cm > F.L. > 10 cm) and screened for the presence of mucus boluses in the oro-pharyngeal cavity. Preserved and fresh branchial baskets were used to measure the dimensions of the total branchial sieve.

Collection of slime boluses

The mucus boluses were collected either by washing them out of the mouth cavity of live fish by using an artificial back flow of water (Fig. 1) or they were collected from the buccal cavity of freshly killed bream after dissection. The volume of the boluses was measured in water to the nearest ml. using a narrow calibrated glass cylinder. Afterwards the boluses were either fixed in 4% formaldehyde solution or stored frozen at -20°C.

Calculation of filter capacity and selectivity

After partly dissolving the mucus by gently stirring in 4% potassium hydroxide solution, the zooplankton in the mucus boluses, as well as in the water samples, were

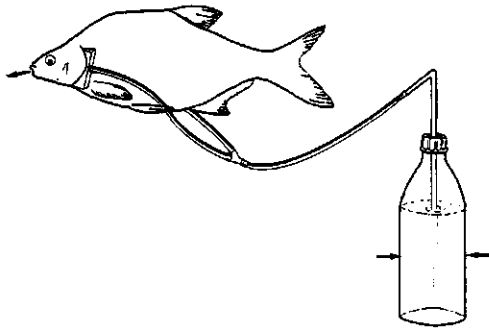

Fig 1. *Collection of mucus boluses from live bream using a back flow of water. The squeeze bottle is compressed to generate a flow of water through the opercular slits and the pharyngeal cavity and outwards through the mouth. This was performed directly after catching.*

identified, measured and counted. The capacity (i.e. the filtered volume of water to retain the zooplankton) and the selectivity of the fish could be calculated because the distribution of zooplankton in the lake is random (De Nie et al., 1980), bream > 15 cm F.L. are filter feeders and the retention of the larger particles (depending on the size of the fish; Hoogenboezem et al., submitted) is 100%. Furthermore the possible effect of visual selection is neglected.

Histology of the oro-pharyngeal cavity

The branchial baskets and palatal organs of some of the freshly captured bream were preserved in Bouin's fluid (Romeis, 1969). Standard procedures were used for histological study (cf. Hoogenboezem et al., 1991a). Sections (5 μm) were cut along the axis of the branchial arches with the palatal organ in its original position just above. From series of five successive sections every first section was stained after Crossmon (Romeis, 1969) for a general picture, to make a 3-D-reconstruction of the total filter apparatus and to measure its surface dimensions. Each second section was stained with Periodic Acid Schiff's (PAS) reagents (McManus et al., 1963) to reveal both acid and neutral mucus-producing cells. Acid mucopolysaccharides and glycoproteins were identified by a positive reaction in staining each third section with Alcian Blue (AB) at pH 2.5 (McManus et al., 1963). A histochemical reaction with High Iron Diamine (HID) on every fourth section

(Spicer, 1965) further distinguished acid sulphomucines (positive staining) from acid sialomucines (negative staining). Subsequent staining with both AB and HID on each fifth section allowed a comparison with the results of the individual dyes.

The size and volume of the different types of mucus producing cells was measured according to the method of Drost and Van den Boogaart (1986) with successive sections of 50 different cells of each cell type. Individual cells were traced although neighbouring sections of the same cell were differently stained. The density (cells/mm²) of the different types of mucus-producing cells was estimated in every tenth slide throughout the entire oro-pharyngeal cavity, taking the size of the different cell types and the thickness of the sections into account.

Histology of mucus boluses

Some of the preserved slime boluses were prepared for histological study. The boluses were placed in small bottles to which an inlet and an outlet tube was constructed. The boluses were carefully rinsed by flowing distilled water slowly for one day through the tubes. In the same way the material was dehydrated by perfusion of ethanol 96%, and impregnated with Technovit solution (Kulzer, Technovit 7100) without hardener. After 24 hours the boluses were carefully placed in a teflon mould, containing Technovit solution with hardener. 1 μm and 5 μm sections were cut on a LKB microtome with a glass knife. The sections were mounted on slides and stained after Crossmon and with toluidine blue, PAS and HID according the standard procedures only with two to three times longer incubation periods.

Results

Occurrence and volume of mucus boluses

From April to November 1988 several hundreds of bream have been caught and screened for the presence of mucus boluses in the oro-pharyngeal cavity. The boluses were most abundant in the spring and summer season coinciding with the period of high zooplankton densities and high temperatures. (Figs. 2a, b and c).

In the first week of June 1988 143 bream were caught in lake Tjeukemeer, of which 20 were smaller than 15 cm F.L., 79 were between 15 and 30 cm F.L. and 44 were larger

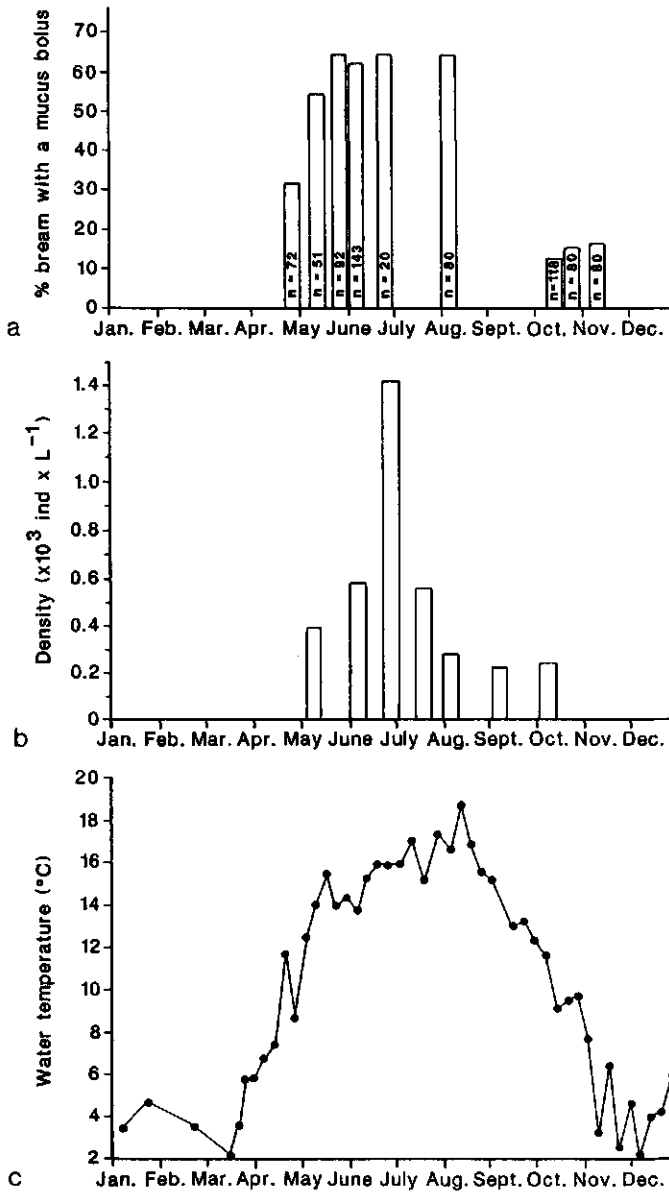
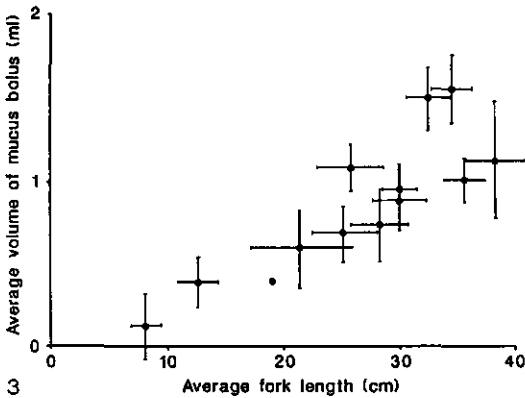

Fig 2a. The percentage of bream, caught at different periods in 1988, which had a mucus bolus in the mouth cavity. n = total number of bream caught on this date.

Fig. 2b. Total zooplankton density (ind. L⁻¹) in the lake in 1988. During the summer season high densities are found, during the winter season no sampling took place.

Fig. 2c. Weekly water temperatures of lake Tjeukemeer during 1988.

than 30 cm F.L. (Tab. 1). From the first group all fish had a mucus bolus, the average volume being 0.23 ml. In the intermediate group 65% possessed a bolus, with an average volume of 0.75 ml and in 63% of the largest fish a mucus bolus was found with an average volume 1,14 ml (Tab. 1 and Fig. 3). In all cases in which the isolated mucus was a distinct bolus, zooplankton was found inside the bolus. If all cases in which mucus was isolated are considered, only 77% contained zooplankters.



tab.1

Fork Length (FL,cm)	Number of fish	% with a bolus	Av. volume of bolus (ml)
< 15	20	100	0.23
15 < FL < 30	79	65	0.75
> 30	44	63	1.14

Fig. 3. Mean fork length (F.L.) versus average bolus volume of bream caught in June 1988 in lake Tjeukemeer. Bars indicate the standard deviation.

Tab. 1. Occurrence and size of mucus boluses among freshly caught bream (first week of June 1988).

The shape of the mucus boluses varies. On the ventral surface the imprints of the branchial arches were occasionally observed. In most cases these boluses were found posteriorly in the pharyngeal cavity, covering the fourth and fifth gill-arch, or a sheet of mucus was covering the entire branchial basket. Due to the soft nature of the boluses their exact dimensions cannot be given.

Contents of the mucus boluses

The mucus boluses usually contained cladocerans (*Daphnia spec.*, *Bosmina spec.* and *Chydorus sphaericus*). Technovit microtome sections (1 μ m) of a mucus bolus showed that each individual food-particle was enveloped by a thin mucus layer or primary envelope, and again, groups of such primary envelopes are embedded in a thin mucus layer or secondary envelope (Figs. 4a and b) and so on. Thus a bolus is a conglomerate

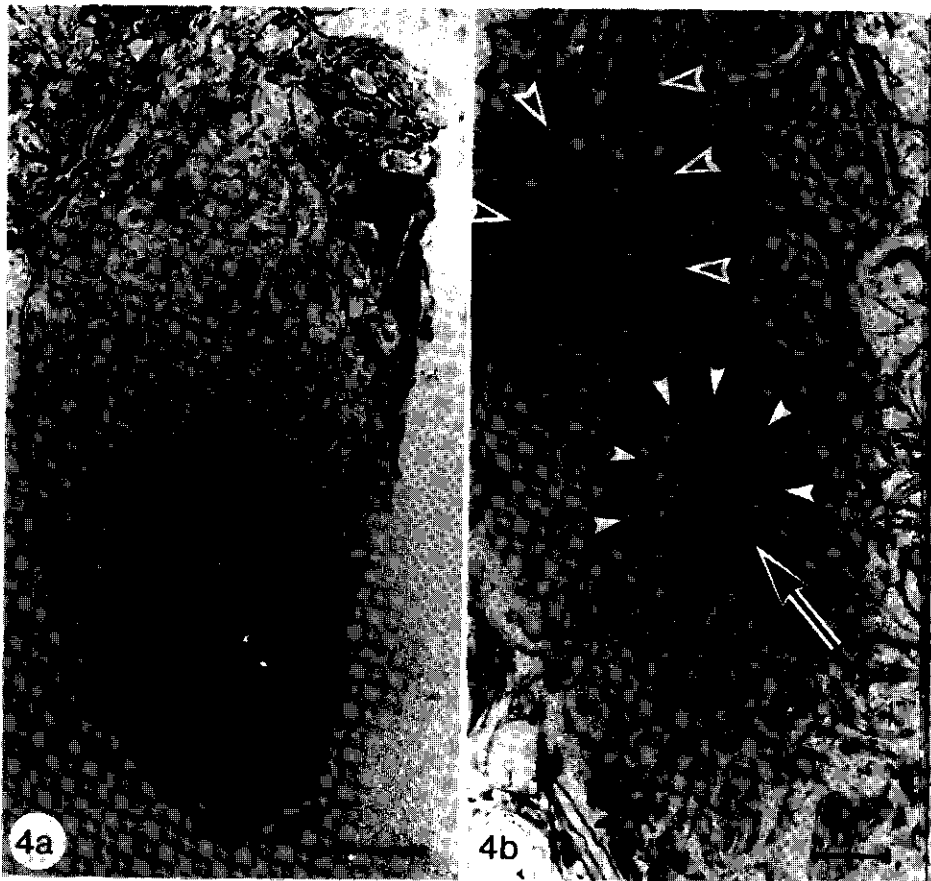

Fig. 4a. Section (1 μ m) through a mucus bolus stained with toluidine blue. Large numbers of cladocerans are enveloped in mucus. Scale bar indicates 1 mm.

Fig. 4b. Magnification of some cladocerans, enveloped in mucus. Arrow indicates an individual cladoceran of about 0.5 mm length. Scale bar indicates 0.2 mm. Note the primary and secondary envelopes of mucus.

of small mucus envelopes. Hardly any algae were found in the isolated mucus, in spite of their abundance in the eutrophic lakes.

Mucus is not only used during pelagic feeding. A trawl in lake Langweerder Wielen in September 1988 yielded 12 bream with a mucus bolus of which 11 appeared to contain benthic material. One bream > 30 cm from lake Tjeukemeer caught in June 1988 had a bolus containing ca 50 small chironomid larvae (Einfeldia spec., Polypedillum spec., Cladotanitarsus spec. and Procladius spec.), which has to be a result of benthic feeding.

Boluses apparently formed during benthic feeding contained also benthic cladocerans (*Alona*, *Leydigia*), sand and debris (0.5 mm < particle size < 2 mm). Apparently also in benthic feeding the foodparticles are enveloped in mucus prior to transport.

Mucus boluses and the seasonal activities of bream

For each bream caught in the first week of June, (when zooplankton density was high: *Daphnia spec.* 125 ind.L⁻¹ and *Bosmina spec.* 530 ind.L⁻¹.) we calculated the retention percentage for zooplankters that are smaller than the mesh size of the sieve. The retention ratios for the small cladocerans in the group of bream > 15 cm F.L. (which use random filter feeding at these densities), show two distinct groups. One with a high retention percentage (average 77% (± 11.9 SD)) and one group with a low retention percentage (average 24% (± 8.5 SD)) (see Tab. 2). Fish < 15 cm F.L. use predominantly particulate feeding (Hoogenboezem et al., 1991b).

No systematic differences were found in contents and morphology of the slime boluses collected from live bream by backwashing and those isolated from dissected bream.

Morphometry of the branchial sieve

For a bream of 32.5 cm fork length, the surface area of the branchial basket including the area of the palatal organ, was 2,750 mm², as calculated from 3D reconstruction of 5 μ m sections. The density of sulphomucine cells increased from anterior (<500/mm²) to posterior (>20,000/mm²) on each ceratobranchial and on the palatal organ above these arches (Fig. 5a and b). The density of the sialomucine cells hardly changes over the total area of the branchial sieve. In the posterior central sieve area (i.e. arches 4, postlingual organ and the corresponding area on the palatal organ just above) a very high mucus cell density (occasionally > 40,000 cells/mm²) was observed, mostly sulphomucine cells.

On gill arch 2, 3 and 4 the density of both mucus cell types is significantly higher on the medial side of each arch than on its lateral side (Mann-Whitney U-test, $p < 0.01$; arch 2: $U=268.5$, $n=19$; arch 3: $U=171.5$, $n=15$; arch 4: $U=134.0$, $n=13$). There is no significant difference in lateral and medial density of mucus cells on the first gill arch ($U=203$, $n=21$) (Fig. 6).

The ratio of the total available volume of sulphomucines and sialomucines in the branchial sieve area is 9:1. The average volume of mucus per cell, reconstructed from serial sections, are 2.7 picoliter (n=50) for sulphomucine and 1.4 picoliter (n=50) for sialomucine. This gives a total inner-cell-slime volume in the anterior part (70%) of the four gill arches (where individual mucus cells were easy to identify) of 27.4 μ l for sulphomucine (number of cells 10.2*10⁶) and 3.12 μ l for sialomucine (number of cells 2.27*10⁶).

Fork length (cm)	Mesh size (MS) of the branchial sieve (mm)	Number of cladocerans found in the bolus >MS	Number of cladocerans found in the bolus <MS	Retention % for cladocerans <MS	Most probable feeding mode
14.5	0.51	0	2		Undefined
16.0	0.57	0	0		
20.5	0.77	0	3		
22.0	0.83	0	0		
25.0	0.96	0	0		
28.5	1.11	0	9		
10.0	0.32	6	0	0	Particulate intake
10.5	0.34	8	0	0	
11.0	0.36	12	1	6	
11.5	0.38	19	2	8	
12.0	0.40	15	24	106	
12.5	0.42	3	0	0	
A					Gulping with low retention for cladocerans < MS Average 24 %
16.0	0.57	44	36	18	
16.0	0.57	25	20	18	
19.5	0.72	89	141	24	
20.5	0.77	4	10	34	
21.0	0.79	95	305	41	
28.0	1.09	77	312	19	
32.0	1.26	37	449	19	
34.0	1.35	1	24	22	
B					Gulping with high retention for cladocerans < MS Average 77 %
15.0	0.53	8	32	100	
16.0	0.57	4	12	67	
16.5	0.60	106	430	77	
18.0	0.66	71	311	76	
19.5	0.72	154	737	71	
33.0	1.30	3	170	70	

Tab. 2. Bolus contents and retention of bream caught in June 1988. Of 26 bream 6 had a volume of mucus without or with hardly any cladocerans. 6 bream were smaller than 15 cm F.L. and supposed to forage by particulate feeding. 8 Specimen (A) were considered to have foraged in the filterfeeding mode, using unreduced channels (URC) resulting in a low retention for cladocerans < their mesh size. 6 Bream (B) have been filterfeeding with reduced channels (RC) resulting in a high retention for cladocerans < their mesh size (the terms URC and RC are explained in Hoogenboezem et. al, submitted). The mesh size (MS) of the sieve of bream is calculated with the formula: $MS = -0.1115 + 0.004286 * FL$ (Van den Berg et al., in press). The retention % for cladocerans < mesh size is calculated with the formula:

$$Ret. \% = 100 \% * (nsb * LDI) / (nlb * LDs)$$

nsb=number of small cladocerans in the bolus

nlb=number of large cladocerans in the bolus

LDs=Lake Density of small cladocerans

LDI=Lake Density of large cladocerans

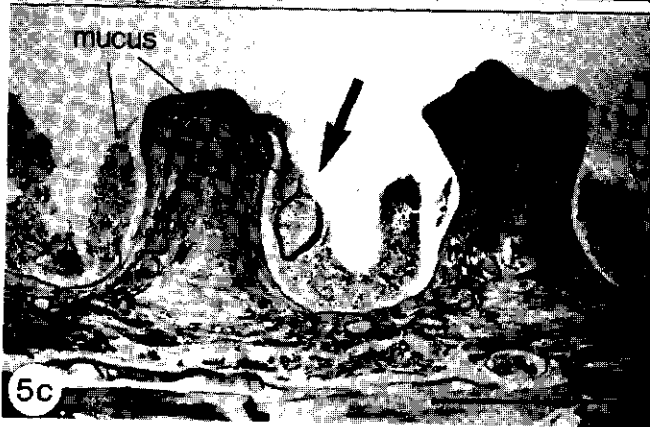
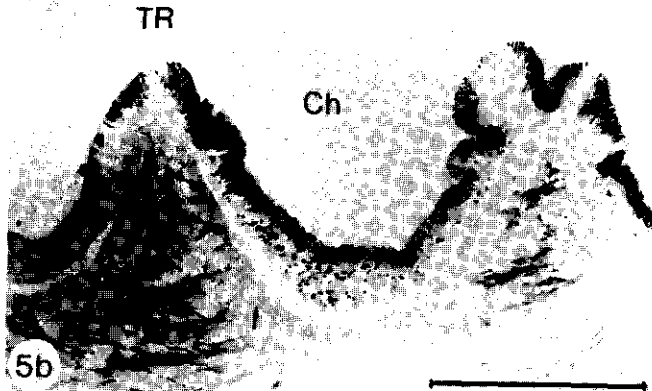

Fig. 5a. Sagittal section (5 μ m) of gill arch 2 and palatal organ of a 30 cm F.L. bream. Mucus cells are stained with HID and AB (small dark spots, tissue is not counterstained). A=anterior, P=posterior, PO=palatal organ, GA=gill arch, Ch=channel, TR=transverse ridge, PS=pharyngeal slit. Note the high density of mucus cells in the wall of the channels and in the opposed palatal organ area. Scale bar indicates 10 mm.

Fig. 5b. Detail of Fig. 5a. Scale bar indicates 1 mm.

Fig. 5c. Section of a 26 cm F.L. bream comparable to Fig. 5b, stained after Crossmon. Note the cladoceran (arrow, i.e. *Bosmina spec.*) in the channel wrapped in mucus. Scale bar indicates 1 mm.

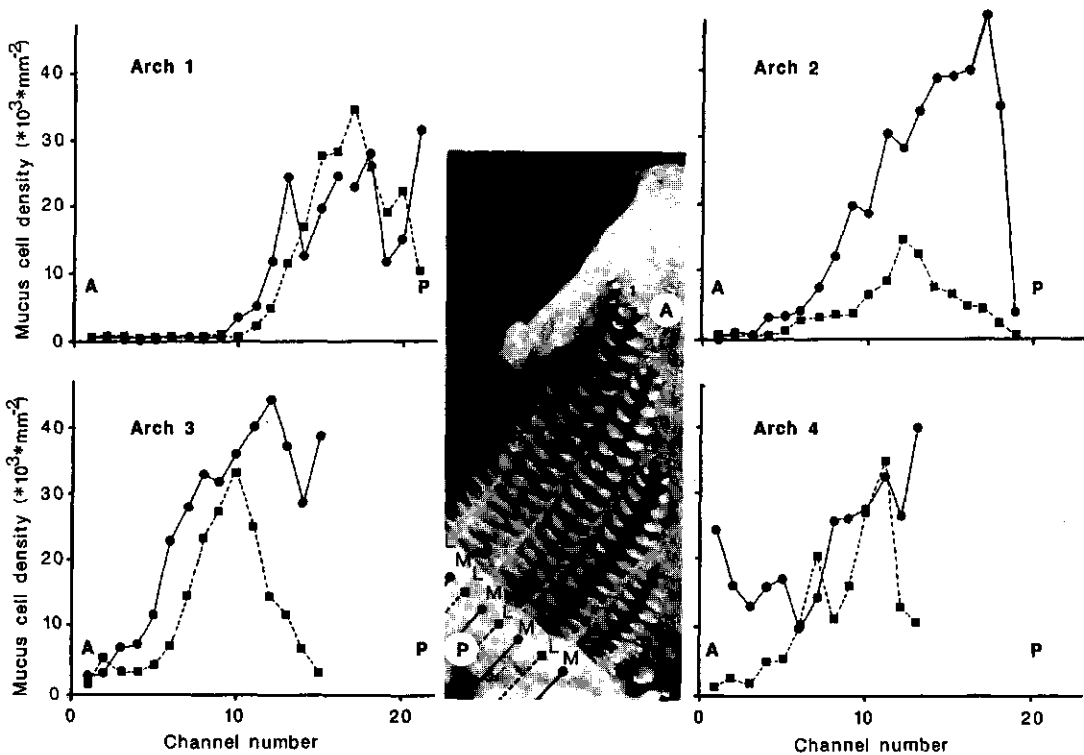

Fig. 6. Density of mucus producing cells found in different parts of the branchial sieve of a bream of 30 cm. The densities are determined in the subsequent channels on the four gill arches (1 - 4). Only the channels which have an opposite channel on the same gill arch are plotted. Note the distinct increase in density posteriorly on the branchial sieve and also the higher numbers on the medial side of each gill arch compared to lateral. A = anterior, P = posterior, l = lateral, m = medial.

Discussion

The role of mucus in the filter feeding process of fishes has been discussed by several authors, most of them consider mucus important for retention. Greenwood (1953) observed a discrepancy between the coarse architecture of the branchial sieve and the tiny phytoplankton organisms (*Melosira spec.*) ingested by *Tilapia esculenta*. Greenwood suggests that these small particles would be entangled in a copious mucus supply, secreted from the epithelium of the buccal and pharyngeal cavity. The mucus-food aggregate is prevented from escaping through the opercular slits by the gill rakers and is transported

posteriorly. Mucus is supposed to be involved here in both particle retention and transport, however it is not clear whether Greenwood actually observed these aggregates. Matthes (1963) described a possible mucus retention mechanism for Labeo, an African cyprinid genus. Thorough mixing in the buccal cavity of tiny food particles (e.g. diatoms) with mucus, should serve aggregation in larger complexes prior to filtering out through the branchial sieve. No special transport or storage function is attributed to the mucus here. These hypothesis have not been tested experimentally.

In view of the distribution of the clavate mucus cells on the gill arches Northcott and Beveridge (1988) assume that in Oreochromis niloticus, mucus forms a net-like structure between the arches and this net should act as the actual sieve. The fry (40-60 mm) of this species appeared to forage effectively on suspended bacteria (Chromatobacterium violaceum). Beveridge et al. (1989) assume that the highly negatively charged mucus facilitates flocculation and entrapment of these very small particles. These studies indeed suggest a special role for mucus in filter feeding, although they lack direct evidence such as presence of mucus-particle aggregates or mucus boluses.

From the interesting endoscopic observation (Sanderson et al., 1991) of mucus-bound particles in live blackfish (Orthodon microlepidotus) it can not be concluded whether the particles were retained in mucus or if they were transported to the esophagus following mechanical-retention.

Sibbing and Uribe (1985) and Sibbing et al. (1986) were, as far as are aware, the first who suggested different roles of different mucus types in the feeding process of carp (Cyprinus carpio). The role of lubrication, reduction of water flow resistance and protection of the epithelium was attributed to the sialomucines, whereas the sulphomucines apart from lubrication and protection play a role in trapping and aggregation of food particles. They based their hypothesis on a combination of detailed histological and feeding mechanism analysis.

The presence of mucus bond zooplankton in bream demonstrates that mucus fulfills a prominent role in its feeding process. The question remains what the actual function of mucus is. Rubinstein and Koehl (1977) consider that a sticky filter surface may function as a retention mechanism, which is unlikely in bream, since the changing selectivity of bream at different food circumstances (Lammens, 1985; Hoogenboezem et al., 1991a) cannot be explained by the mechanism of a sticky filter. Furthermore the contents of the

analysed mucus boluses showed a different selectivity for small cladocerans between fishes (e.g. 24% and 77%; Tab. 2). Also planktonic algae were absent in the bolus, whereas huge numbers of algae were present in the environment, and benthic feeding bream had hardly any debris particles smaller than the mesh size of their sieve in their boluses.

Most probably the mucus serves to transport relative small particles from the retention site in the channels to the oesophagus.

Model

We hypothesize the role of mucus in filter feeding of bream in three steps: 1. wrapping, 2. accumulating and 3. storage and transport.

Water containing food particles is engulfed, and the particles are retained mechanically in the channels of the gill-arches (Hoogenboezem et al., 1991a), without interference of mucus.

1. **Wrapping.** The contact between particle and channel surface stimulates mucine secretion around the prey, wrapping it in a primary mucus sheet. Now the mucus enveloped particles are supposed to behave as sticky particles, ready to be manipulated and transported.
2. **Accumulating.** After a number of gulps, when clogging starts to impede the filter action and reduce its capacity per unit time, these sticky particles are flushed back from the sieve to the mouth cavity by a closed protrusion movement: During closed protrusion the buccal cavity is expanded while the lips are kept closed, causing a water flow from the open opercular slits into the oral cavity in anterior direction (Sibbing, 1986, 1991). During compression of the buccal cavity different particles wrapped in a primary sheet of mucus stick together here and form a small mucus bolus, which is transported to the posterior part of the pharyngeal chamber (between palatal and postlingual organ) and sticks to the abundant mucus in that area or to a previously formed bolus. This again will stimulate mucine secretion in this area so the total aggregate is enveloped in mucus once again (second sheet).
3. **Storage and transport.** For several of these wrapping and accumulating cycles the bolus remains stored in the central posterior area of the pharyngeal cavity and will grow larger. By muscular peristalsis of the palatal and postlingual organ the large

bolus is transported effectively towards the esophagus. Through pharyngeal jaw movement also squeezing of the particles will occur. The bolus will be swallowed subsequently (c.f. Sibbing et al., 1986).

Evidence for 1. is provided by microscopical observations of the technovit slides of a mucus bolus, which show that each single prey-item in the bolus is enveloped in mucus (Figs. 4a and b) and by the microscopic observation of a section of a gill arch with a zooplankter wrapped in mucus in a channel (Fig 5c). The first step of this model is consistent with an adjustable filter system (Hoogenboezem et al., 1990; 1991a), where channels are supposed to be the retention site of the prey, and particularly the medial channels for the small prey. The higher mucus cell density in the medial channels, as observed in this study (Fig. 6), is in correspondence with and an important additional support for this. Retained particles may stimulate these cells to discharge the mucus by direct contact. Discharge of mucus may also be aided by muscle activity. The cushionlike structure of the raker contains a complex network of muscle-fibers; the musculus constrictor canalis interbranchiospinalis (Hoogenboezem et al., 1991a). Contraction of this muscle may increase mucus discharge forming a mucus web, e.g. prior to closed protrusion movements.

The second step in the process agrees with the distinct subunits in the bolus, seen microscopically. The enormous density of mucus cells in the posterior part of the pharyngeal cavity produces the mucus required for accumulation, growth and storage of small aggregates of this material in this area. Frequent closed protrusion movements during filterfeeding (also in carp, c.f. Sibbing et al., 1986: Fig 4a) further support these ideas.

The third step is confirmed by the fact that foraging bream stores strained zooplankton for quite some time in the pharyngeal cavity. Particle counts per bolus revealed up to 150 prey-items larger than the mesh size of a 19.5 cm bream (Tab. 2), which means that a volume of 1.05 l of water should have been filtered. Bream of this length is able to process ca 4.5 ml water per snap (Mouth volume = $6 \cdot 10^{-6} \cdot F.L.^3$, Hoogenboezem et al., 1991b), thus over 220 snaps were taken to collect and retain these particles from the environment. The snap frequency of bream of this size class is estimated on ca 1.2 snaps/s (Hoogenboezem et al., 1991b), therefore it took over three minutes to constitute

this bolus. Since bolus formation requires several minutes, the actual volume and contents of the bolus of a fish caught at a certain moment may vary from a low to a maximal value. The ratio between large and small prey-items is not necessarily influenced in this time span, assuming random filter feeding.

Video recordings of foraging bream in an aquarium containing a zooplankton composition comparable with the lake, revealed closed protrusion movements about every 10 seconds, which is also confirmed by earlier X-ray experiments of bream foraging on high zooplankton density ($> 100 \text{ ind L}^{-1}$) (Hoogenboezem et al., 1990). We therefore must address the question whether mucine production is high enough to produce a sufficient volume of mucus every 10 seconds.

The volumes of inner cell mucines in bream were between 1.4 and 2.7 picoliter. According to Verdugo (1984) mucines have a swell ratio of 10^2 - 10^3 . Sheehan and Carlstedt (1984) report that a concentration of mucin of 0.5 mg/ml is sufficient to start physical entanglement (i.e. mucin molecules start to interpenetrate to form a mucus web). A single cell in the mammalian respiratory tracts is able to produce 9-18 nl mucus per minute (Widdicombe, 1988) which means at least a production of 9-18 picoliter mucine per cell per minute. So if we use this number and a swell factor of 10^3 for the mucus cells of bream, the total production of mucines in bream can be calculated. The number of mucus producing cells in the anterior 70% of the pharyngeal sieve (i.e. the actual retention site; about 2000 mm^2) is sufficient to produce a continuous mucus layer of 35 μm thick over this area every 10 seconds! The actual inner cell volume of mucus cells in bream is probably underestimated since measurements were carried out on fixed material causing a shrinkage of ca 30% (Drost and Van den Boogaart, 1986), on the other hand mucine production in poikilotherm fish will be lower compared to homoiotherm mammals. Still, we believe that the above mentioned production is sufficient for the explanation of the described mechanism.

All the above data fit the picture of a fish retaining small food particles, later covering them with mucus and accumulating these aggregates in greater lumps prior to deglutition. This mucus based food aggregation mechanism is convergent with filtering systems found in early agnath vertebrates (Lessertisseur and Robineau, 1969) and in recent cephalochordates. Apparently the abundance of small but highly nutritive particles in the

water column provide such an important source, that new mechanisms have evolved to harvest them. In bream, maybe in cyprinids in general, the combination of the use of mucus with an adjustable branchial filter provides a successful way to expand as a species in man-made eutrophic environments.

Acknowledgements

We thank J.W.M. Osse, F.A. Sibbing (Wageningen) and E.H.R.R. Lammens, J. Vijverberg (Oosterzee) for their stimulating discussions and critical remarks on the manuscript. B. v.d. Bergh and T. Machielsen are kindly acknowledged for their help in collecting ecological and histological data. The investigation was supported by the Foundation for Fundamental Biological Research (BION), which is subsidized by The Netherlands Organization for Scientific Research (NWO), project 811-437-241B.

Literature

- Beveridge M.C.M., M. Begum, G.N. Frerichs and S. Millar. 1989. The ingestion of bacteria in suspension by the Tilapia Oreochromis niloticus. Aquaculture, 81: 373-378.
- De Nie H.W., H.J. Bromley and J. Vijverberg. 1980. Distribution patterns of zooplankton in Tjeukemeer. The Netherlands J. of Plankton Res. 2(4): 317-334.
- Drenner R.W., W.J. O'Brien and J.R. Mummert. 1982. Filter-feeding rates of Gizzard Shad. Trans. Am. Fish. Soc., 111: 210-215.
- Drost M.A. and J.G.M. van den Boogaart. 1986. A simple method for measuring the changing volume of small biological objects, illustrated studies of suction feeding by fish larvae and the shrinking due to histological fixation. J. Zool. Lond. (A) 209: 239-249.
- Greenwood, P.H. 1953. Feeding mechanism in Cichlid fish, Tilapia esculenta Graham. Nature Lond. 172: 207-208.
- Hoogenboezem W., F.A. Sibbing, J.W.M. Osse, J.G.M. van den Boogaart, E.H.R.R. Lammens and A. Terlouw. 1990. X-ray measurements of gill-arch movements in filter feeding bream (Abramis brama, Cyprinidae). J. Fish Biol. 36: 47-58.
- Hoogenboezem, W., J.G.M. van den Boogaart, F.A. Sibbing, E.H.R.R. Lammens, A. Terlouw and J.W.M. Osse. 1991 (a). A new model of particle retention and branchial sieve adjustment in filter-feeding bream (Abramis brama, Cyprinidae). Can. J. Fish. Aquat. Sci. 48: 7-18.

- Hoogenboezem, W., E.H.R.R. Lammens, Y. van Vugt and J.W.M. Osse 1991 (b). A model for switching between particulate-feeding and filter-feeding in the common bream, Abramis brama. Env. Biol. Fish. in press.
- Hoogenboezem, W., E.H.R.R. Lammens, P.J. MacGillavry and F.A. Sibbing. (Submitted). Prey-size selectivity and sieve adjustment in filter-feeding bream (Abramis brama (L.), Cyprinidae).
- Lammens, E.H.R.R. 1985. A test of a model for zooplanktivorous filter-feeding by bream (Abramis brama). Env. Biol. Fish. 13: 288-296.
- Lammens, E.H.R.R. and W. Hoogenboezem. 1991. Diets and feeding behavior. In: Winfield I.J. and J. Nelson (ed.) Cyprinid fishes. Systematics, biology and exploitation. Chapman and Hall, London. 353-377.
- Lammens, E.H.R.R., J. Geursen, and P.J. McGillavry. 1987. Diet shifts, feeding efficiency and coexistence of bream (Abramis brama), roach (Rutilus rutilus) and white bream (Blicca bjoerkna) in hypertrophic lakes. Proc. V Cong. Eur. Ichthyol. 153-162.
- Lammens, E.H.R.R., H.W. de Nie, J. Vijverberg and W.L.T. van Densen. 1985. Resource partitioning and niche shifts of bream (Abramis brama) and eel (Anguilla anguilla) mediated by predation of smelt (Osmerus eperlanus) on Daphnia hyalina. Can. J. Fish. Aqat. Sci. 42: 1342-1351.
- Lessertisseur, J., and D. Robineau. 1969. Le mode d'alimentation des premieres vertebres et l'origine des machchoirs. 494e Reunion des naturalistes du museum. 83-121.
- Matthes, H.M. 1963. A comparative study of the feeding mechanisms of some African Cyprinidae (Pisces, Cypriniformes). Bijdr. Dierk. Amsterdam 333: 3-35.
- McManus, J.F.A. and R.W. Mowry. 1963. Staining methods. Histologic and histochemical. Hoeber, New York.
- Northcott, M.E. and M.C.M. Beveridge. 1988. Development and structure of the pharyngeal apparatus associated with filter feeding in tilapias (Oreochromis niloticus). J. Zool. Lond. 215: 133-149.
- Romeis, B. 1968. Mikroskopische techniek. Munchen-Wien, Oldenburg.
- Rubinstein, D.L. and M.A.R. Koehl. 1977. The mechanism of filter-feeding: some theoretical considerations. Am. Nat. 11: 981-994.
- Sanderson, S.L., J.J. Cech, Jr., and M.R. Patterson. 1991. Fluid dynamics in suspension-feeding blackfish. Science 251: 1346-1348.
- Sheehan, J.K. and I. Carlstedt. 1984. Hydrodynamic properties of human cervical-mucus glycoproteins in 6M-guanidinium chloride. Biochem. J. 217: 90-101.
- Sibbing, F.A. 1991. Food capture and oral processing. In: Winfield I.J. and J.S. Nelson (ed.) Cyprinid fishes Systematics, biology and exploitation. Chapman and Hall, London. 377-413.
- Sibbing, F.A., J.W.M. Osse and A. Terlouw. 1986. Food handling in the carp (Cyprinus carpio): its movement patterns, mechanisms and limitations. J. Zool. Lond. (A)210: 161-203.
- Sibbing F.A. and R. Uribe. 1985. Regional specializations in the oropharyngeal wall and food processing in carp (Cyprinus carpio). Neth. J. Zool. 35(3): 377-422.

- Spicer, S.S. 1965. Diamine methods for differentiating mucosubstances histochemically. *J. Histochem Cytochem.* 13: 211-234.
- Van den Berg, C., F.A. Sibbing, J.W.M. Osse and W. Hoogenboezem. 1991. Structure, development and function of the branchial sieve of bream (*Abramis brama*), white bream (*Blicca bjoerkna*) and roach (*Rutilus rutilus*). *Env. Biol. Fish.* in press.
- Verdugo, P. 1984. Mucus and Mucosa. *Ciba Found. Symp.* 109: 212-225. Pitman, London.
- Widdicombe, J.G. 1988. Methods for collecting and measuring mucus from specific sources. In: Braga, P.C. and L.A. Allegra (ed.). *Methods in brochial mucology.* Raven Press, New York.

DANKWOORD

Allen die hebben bijgedragen aan het tot stand komen van dit proefschrift dank ik hartelijk voor hun enthousiaste hulp en voor de prettige wijze van samenwerking:

Mijn ouders dank ik voor hun stimulerende belangstelling voor mijn studie en werk.

Mijn promotor Jan Osse dank ik voor de grondige discussies over de mogelijke werking van de kieuwzeef en de biologie van brasems maar ook voor de "doorkijk" naar een breder verband. Jouw kritische beschouwing van de verkregen resultaten hebben ertoe bijgedragen dat er nu een wezenlijk inzicht is in de werking van de kieuwzeef bij de brasem. Laten we hopen dat het van "beton" zal blijken.

Eddy Lammens, jouw nooit verminderende enthousiasme en hulp voor dit onderwerp maakte het werk tot een uitdaging en stimuleerde telkens weer tot verder onderzoek. Nand Sibbing, ik heb dankbaar gebruik gemaakt van jouw uitgebreide kennis en ervaring op het gebied van de analyse van röntgenfilms, een belangrijk deel van dit werk.

Jos van den Boogaart, jouw hulp is van grote waarde voor het onderzoek geweest. De inventieve wijze waarop jij in veel gevallen een praktische oplossing voor onze problemen vond heeft het uiteindelijk resultaat gunstig beïnvloed en aanzienlijk versneld.

Peter McGillavry, jou bedank ik voor het geduld waarmee jij de bijna eindeloze hoeveelheid monsters, zo zorgvuldig en betrouwbaar hebt afgewerkt.

Koos Vijverberg, jouw stimulerende betrokkenheid bij mijn werk en jouw commentaren bij de manuscripten heb ik zeer gewaardeerd.

Annet Kroon, mijn voorganger in dit project, heeft een goed gedocumenteerde verzameling gegevens van voedsel-proeven en röntgenfilms voor mij achter gelaten, waarvan ik dankbaar gebruik heb gemaakt.

Arie Terlouw, bedankt voor je vakkundige hulp bij het opnemen van de röntgenfilms.

Bert van de Bergh heeft voor zijn doctoraal-onderzoek aan het slijm onderzoek gewerkt en de spier-reconstructies.

Yvette van Vugt heeft tijdens haar studenten onderwerp de mond-volumina en de kanaaldiameters van verschillende brasems gemeten.

Trudy Machielsen heeft voor haar afstudeeropdracht de verdeling van slijmcellen bij brasem bepaald en gezorgd voor een goed bruikbare serie histologische coupes van de kieuwzeef.

Onno v. Tongeren, Ramesh Gulati hebben waardevolle commentaren geleverd op verscheidene manuscripten.

Wim Valen heeft met veel vakmanschap een aantal prachtige illustraties gemaakt.

Riet en David van Cittert, bedankt dat ik bij jullie mocht logeren.

Wolf Mooij, Maarten Boersma, Aafje en Theo Landman, Bauke Vlink, Hans Hoogveld, Koos Swart en de andere collega's van het Limnologisch Instituut. Coen v.d. Berg, Rie Akster, Mees Muller, Sjo Koumans en de overige collega's van de sectie functionele morfologie. Tineke van Cittert, tijdens mijn soms langdurige afwezigheid heb jij de zorg van het huishouden en de kinderen, ondanks je eigen werk, geheel op je genomen, waardoor ik me volledig aan het werk kon wijden. Ook Daphne en Remco hebben hun bijdrage geleverd door de rust te geven tijdens de vele "vrije-uren" die voor dit werk nodig bleken. Als blijk van dank hiervoor wil ik het proefschrift aan Tineke, Daphne en Remco opdragen.

CURRICULUM VITAE

Wim Hoogenboezem werd op 30 juli 1950 te Rotterdam geboren. Na de lagere school werkte hij van 1965 tot 1977 achtereenvolgens als chemisch laborant bij Handels Laboratorium v/h Dr. A. Verweij te Rotterdam, als amanuensis voor biologie, scheikunde en bodemkunde bij de hogere- en middelbare landbouwschool te Dordrecht en bij het Centraal Diergeneeskundig Instituut te Rotterdam als bacteriologisch- en zoölogisch laborant.

In 1973 behaalde hij het MAVO IV diploma, in 1977 gevolgd door het atheneum B diploma, aan de Rotterdamse Avondscholengemeenschap. In dat jaar werd een begin gemaakt aan de biologiestudie aan de Universiteit van Leiden. Het kandidaatsexamen werd in 1981 behaald. In de doctoraalstudie stond de zoölogie centraal, zoals blijkt uit de gekozen doctoraal-onderwerpen:

- 1) Taxonomische studie aan de zoogdieren van Nieuw Guinea, o.l.v. dr. C Smeenk, Rijksmuseum van Natuurlijke Historie.
- 2) Functioneel morfologisch onderzoek naar de verspreiding van de smaakknoppen bij verschillende Oost Afrikaanse cichliden, o.l.v. dr. C.D.N. Barel, zoölogisch laboratorium.
- 3) Een onderzoek naar de ontwikkeling en fluctuaties van het zoöplankton in de Mwanza golf (Victoria meer) en de voedselselectie van een dominante zoöplanktivore karperachtige (Rastrineobola argenteus) in dat gebied, o.l.v. drs. F. Witte, zoölogisch laboratorium.

Het doctoraal diploma werd in 1985 behaald. In juli 1986 werd gestart met het BION-project dat het onderwerp vormt van dit proefschrift.

Sinds mei 1990 is hij werkzaam als chef biologisch laboratorium bij de NV provinciaal waterleiding bedrijf Noord-Holland.