

## Clean Vector Technology for Marker-free Transgenic Ornamentals

F.A. Krens, K.T.B. Pelgrom, J.G. Schaart, A.P.M. den Nijs and G.J.A. Rouwendal  
BU Biodiversity and Breeding  
Plant Research International  
P.O. Box 16  
6700 AA Wageningen  
The Netherlands

**Keywords:** Gene transfer, excision, recombination, safe GMOs, apple, strawberry, lily, *Chrysanthemum*

### Abstract

**Marker-free transgenic crops confer several advantages over transgenic crops equipped with e.g. genes coding for antibiotic resistance. Firstly, the European Union encourages notifiers for introductions of GMOs in the environment to “avoid or minimize the inclusion of superfluous transgenes or sequences” and it promotes the use of clean vector systems. Secondly, the number of selection genes allowing the preferential growth of transformed cells and tissues is limited and often a gene transfer protocol for a specific crop or even a cultivar depends on the use of one specific selectable marker gene. Hence, stacking of genes within the same transgenic line is difficult once a selectable marker gene has been introduced. If these marker genes can be removed, the subsequent introduction of the next gene-of-interest is greatly facilitated. At Plant Research International a system has been developed for specific elimination of any introduced DNA/gene sequences using site-specific recombination combined with selection for successful removal using a negative selection system. Completely marker-free transgenic plants have been obtained using a model vector, both in an efficient transformation system (strawberry) as well as in a non-efficient transformation system (apple). Frequencies were more than adequate. Presently, A versatile vector set providing a choice of several selectable markers and carrying a multiple cloning site for receiving cassettes of the gene-of-interest is available for application in, amongst others, ornamental crops.**

### BACKGROUND

Genetically modified (GM) food products are looked upon with a certain degree of mistrust by the majority of European consumers. Almost 50 % of the consumers think that GM food is less safe for human consumption than non-GM food products. 33 % is not sure. Only 20 % of the consumers know that there is no scientific basis to these doubts on food safety. While on the one hand players in the food production chain, such as breeding companies, growers/farmers and biotechnology firms, are convinced of the technical and economic benefits, the consumers on the other hand perceive risks to human health, to the environment and to biodiversity. In the USA and other countries around the globe, e.g. Argentina, Canada, China, and India, GM crops are more and more implemented in agriculture, however, the European input in research and development of GM crops has been reduced from 1998 on. This de-facto moratorium on the introduction of new GM crops has been in force since 1999. As a consequence of this, 51 % of the European Small and Medium Enterprises (SMEs) at present do not use genetic engineering approaches, but most of them indicated that there has been a change in their strategy in the last few years abandoning GM related R&D projects.

Recently in July 2003, the ban on import of GM food products has been lifted by the European Union (EU) with the proviso, that all products containing more than 0.9 % of EU-approved GM material have to be labelled. Also, the European Parliament has formulated guidelines based on their desire to provide the European consumers with a choice to either accept or avoid the consumption of any GM or GM-derived food products. For this, completely separated production and processing chains will have to be

set up. In practice, this might turn out to be too expensive for the industry presenting yet another barrier to the implementation of GM food in Europe. Another consequence of this EU policy is the negative impact it has on imports of food from the USA and the reluctance of developing countries to grow GM crops out of fear to reduce their export possibilities to the EU.

In order to change the perception of the EU consumers it might not be advisable to force GM crops and food upon them by enforcing official WTO rules and by too much pressure by the USA. Instead, consumers should regain confidence and trust in their scientists and government organizations. This can only be achieved by communicating clearly the benefits of particular GM crops and by highlighting the relevance of these crops to the individual consumer. Consumers should be able to relate to the goals of the modification and to the way followed to achieve these goals. If applicable, it should be explained that alternatives do not really exist or are less beneficial than the GM approach. Next to this, technical solutions to some of the concerns that consumers expressed are sought by science and can be applied.

In a 'Guidance Document for the risk assessment of GM plants and derived food and feed' by the Joint Working Group on Novel Foods and GMOs prepared for the EU recommendations encompass amongst others the encouragement of notifiers to develop GM crops in which only DNA essential to the desired modification is introduced, e.g. clean vector technology. Overall, three principle ways are identified:

- avoid or minimize the inclusion of superfluous transgenes or sequences;
- avoid or minimize superfluous expression of the transgene;
- avoid or minimize the dispersal of transgenes in the environment.

Plant Research International (PRI) has extended this view to all GM-crops including ornamentals and added to this list the preferential use of gene sequences or promoters which are species- or at least plant-derived. This combined with PRI's own clean vector system and transparent communication on PRI arguments why and when to use GM technology will hopefully contribute to a broader public acceptance of genetic modification of plants.

## **CLEAN VECTOR TECHNOLOGY**

Clean vector technology aims to produce GM plants with only the gene-of-interest as newly introduced gene function, so without any superfluous gene sequences. Primarily, the goal is to avoid the use or the continued presence of antibiotic resistance genes as selectable markers. Four approaches to achieve this can be followed.

### **A. No Selectable Marker**

Here, GM plants are produced by *Agrobacterium* inoculation followed by regeneration of shoots without the use of a selectable agent. This will lead to a (great) number of plants, the majority of which are non-transgenic. However, depending on the regeneration and gene transfer frequencies, some plantlets will be transgenic and they will have to be identified, e.g. by a dedicated PCR screening on DNA of several sets of pooled plants. A prerequisite is a regeneration/transformation protocol of high efficiency. So far, this method is limited to model species and a low number of specific crop cultivars, e.g. in potato.

### **B. Cotransformation**

In this system the selectable marker gene is physically separated from the gene-of-interest. This can be on different T-DNAs residing on the same or on separate binary vector(s). The separate binary vectors can be present in the same or in separate *Agrobacterium* strains. The two T-DNAs should become integrated in two genetically unlinked loci. After selection for the GM plants by growth on antibiotic or herbicide containing media subsequent segregation after sexual crossing of resistant regenerants should result in GM plants equipped only with the gene-of-interest. A prerequisite here is that the crop can be sexually propagated without losing too many traits or cultivar identity and this within a reasonable time frame. For vegetatively propagated crops or crops with a very long sexual cycle, such as tulip or

apple, this approach is less feasible.

### C. **Non-Antibiotic-Based Selection**

The most well known example in this respect is, of course, herbicide tolerance. However, also in this case there might be aspects linked to it that can be considered undesired by certain consumer groups. An alternative system that was developed recently is based on metabolic processes, more particularly on the carbohydrate metabolism. The phospho mannose isomerase (PMI) system is based on the fact that plant cells in tissue culture cannot metabolise mannose and therefore, cannot grow on medium with this compound as a sole source of carbon. By providing GM cells with a gene converting mannose into fructose this barrier is overcome and GM plantlets can be obtained. As a consequence, however, they then still carry this bacterium-derived selectable marker gene at a stage where it is actually no longer needed, i.e. in crop cultivation.

### D. **Excision by Recombination**

In this approach selectable marker genes or rather any unwanted (or no longer wanted) gene sequence, can be physically removed from the GM cells or regenerated GM plants. Necessary is a recombinase enzyme working on two specific recombination sites. All of this has to be introduced into the primary transformants, next to the gene-of-interest and the selectable marker gene. Placing everything, which has to be removed ultimately, between the recombination sites ensures that in the final GM plant product only the gene-of-interest remains. Control over the recombinase activity is essential. This can be achieved by regulating or inducing expression of the recombinase gene or by inducing recombinase enzyme activity. Problems related to this technique are leakiness of the recombinase regulation, effectiveness of the induction process and recovery of 100 % homogeneous recombined GM plants. Using a negative selection marker for transgenic, non-recombined cells or plantlets can cover this last aspect. This means that the prolonged presence of the negative selection gene will lead to cell death or an easily identifiable aberrant phenotype. Only the desired marker-free plants survive or will look normal.

The induced expression of a recombinase gene (Cre) is reported by Zuo et al. (2001), where a promoter is used comprising an estrogen receptor-based transactivator. Ebinuma et al. (1997) used the *ipt* gene as a phenotypical negative selection marker, the presence of which results in an aberrant phenotype. At Plant Research International we use a synthetic copy of the recombinase (R) gene of *Zygosaccharomyces rouxii*, which is fused to the ligand binding domain (LBD) of a corticosteroid receptor. The R gene is continuously expressed, but the protein is inactive due to the translational fusion to LBD. Activity can be re-established by treatment with dexamethason (DEX). A dual positive-negative selectable marker consisting of a fusion between the *nptII* gene (positive) and the *codA* gene (negative) are also a part of the PRI system. The *nptII* gene provides the cell with the competence to grow on medium supplemented with e.g. the antibiotic kanamycin, i.e. positive selection. The cytosine deaminase (*codA*) gene product converts fluorocytosine (FC; non-toxic) into the toxic fluorouracil (FU), hence cells carrying this gene will die on medium with FC, i.e. negative selection. As stated earlier all of these elements are placed between the two Rs recombination sites.

The steps required for the production of marker-free GM plants are:

- 1) Inoculation of explants with *Agrobacterium* carrying the appropriate vectors as binary plasmids, according to established protocols.
- 2) Selection of transgenic material by growth on antibiotic containing media, again according to existing protocols.
- 3) Induction of recombinase activity by applying a DEX treatment.
- 4) Selection for marker-free plantlets by applying regeneration protocols in the presence of FC as a negative selectable agent for non-successful recombination events.
- 5) A thorough molecular characterization of the end products should confirm the transgenic and marker-free nature of the plants produced.

In Fig. 1 a model vector, pRCNG, is presented showing all the aforementioned elements. In addition it contains the GUS coding region without a promoter. One Rs site is present between the R gene and the 35S promoter driving its expression. Upon recombination the 35S promoter is combined with the *gus* gene leading to GUS positive staining as a confirmation of the recombination event. An copy of the *hpt* gene outside the Rs sites in this model vector allows further use of positive selection when required.

The model construct has been successfully applied in potato, strawberry and apple (Schaart et al.). The first two represent efficient transformation systems and the latter being much more recalcitrant. So far, the system of recombinase activity inhibition and induction by DEX did not prove to be 100 % effective. However, combined with the existing protocols and tissue culture/regeneration expertise in the crops tested, it easily led to many homogeneous marker-free GM plants, indicating that 100 % effectiveness is not required.

A 'standard' vector (Fig. 2) has been assembled with all and only the elements needed, now including promoter-driven R expression between the Rs sites and a multiple cloning site (MCS) outside them allowing introduction of any gene (expression) cassette leading to the trait of choice. At present, we are testing the efficiency of these new vectors based on the 'standard'. In apple, a gene conferring scab resistance derived from barley was equipped with the rubisco promoter of *Chrysanthemum* for application in our marker-free system; in strawberry a strawberry disease-resistance gene was combined with a strawberry tissue-specific promoter. For ornamental crops, new standard vectors are being made, e.g. containing the dual positive-negative selectable marker under control of the rubisco promoter of chrysanthemum for application in this crop. In another example the vector contains a dual positive-negative selectable marker based on a fusion between the *hpt* gene (hygromycin resistance, positive) and the *codA* gene (negative) for application within bulbous ornamental crops such as lily and gladiolus.

This concurs with the Plant Research International strategy for the production of a new generation of GM crops: marker-free, containing preferably a combination of a plant (or species) derived promoter and a plant (or species) derived gene (see earlier). This, we sincerely hope, will lead to a broader acceptance of these crops by a majority of the public, although it is acknowledged that this approach represents merely a technical solution to some of the objections, and not an answer to every issue raised by consumers at the moment.

Plant Research International is willing to enter into collaborations with interested parties to apply the system on specific crops of interest.

### Literature Cited

- Ebunima, H., Sugita, K., Matsunaga, E. and Yamakado, M. 1997. Selection of marker-free transgenic plants using the isopentenyl transferase gene. Proc. Natl. Acad. Sci. USA 94: 2117-2121.
- Graff, G.D. and Newcomb, J. February 2003. Agricultural Biotechnology at the Crossroads. Part I: The changing structure of the industry., Bio Economic Research Associates, Cambridge, USA.
- Guidance Document for the Risk Assessment of Genetically Modified Plants and Derived Food and Feed. By The Joint Working Group on Novel Foods and GMOs, European Commission Health & Consumer Protection Directorate-General. March 2003.
- Menrad, K. and Menrad, M. March 2003. Anticipating commercial introduction of new GMOs in the (enlarged) European Union. Results of a written survey among companies and research institutes. Fraunhofer Institute for Systems and Innovation Research, Karlsruhe, Germany.
- Schaart J.G., Krens, F.A., Pelgrom, K.T.B. and Rouwendal, G.J.A. Efficient production of marker-free transgenic strawberry plants using inducible R/RS site specific recombination and a hybrid positive-negative selectable marker gene. Manuscript in preparation.
- Zuo J., Niu, Q.-W., Möller, S.G., and Chua, N.-H. 2001. Chemical-regulated, site-specific

DNA excision in transgenic plants. Nature Biotechnol. 19: 157-161.

**Figures**

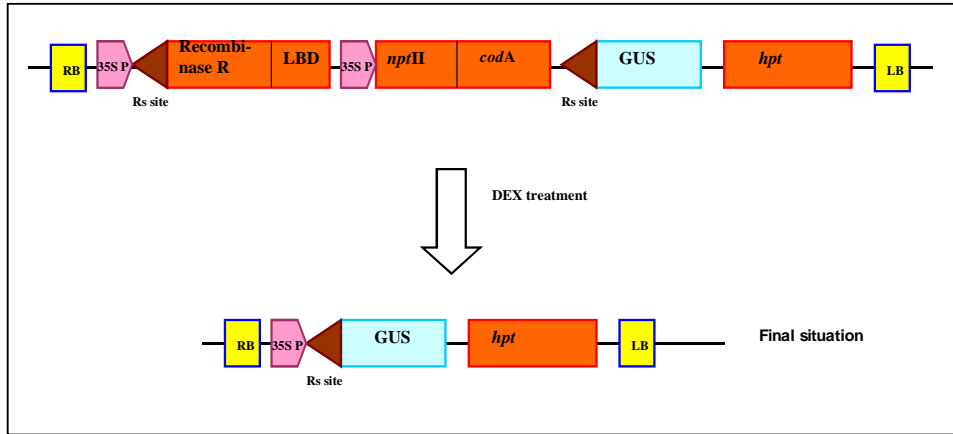

Fig. 1. The pRCNG modelvector

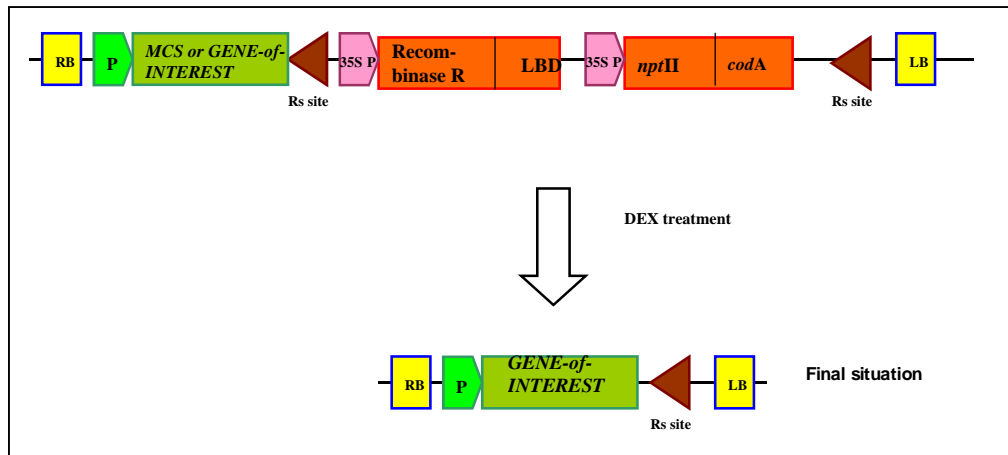

Fig. 2. The standard MF-vector (MF=marker-free)