

RIVO-Netherlands Institute for Fisheries Research

P.O. Box 68	Centre for Shellfish Research
NL 1970 AB Ymuiden	P.O. Box 77
The Netherlands	NL 4400 AB Yerseke
Phone: +31 255 564646	The Netherlands
Fax: +31 255 564644	Phone: +31 113 672300
E-mail: fisheriesresearch.asg@wur.nl	Fax: +31 113 573477
Internet: www.rivo.wageningen-ur.nl	

Report

Number: C022/05

Dioxins in Food and Feed – Reference Methods and New Certified Reference Materials (DIFFERENCE)

S.P.J. van Leeuwen, L. Goeyens, J. van Loco, S. Carbonnelle, I. van Overmeire, H. Beernaert, R. van Cleuvenbergen, G. Schoeters, E. Björklund, S. Sparring, M. Abalos, E. Abad, J. Rivera, J. Santos, W. Traag, R. Hoogenboom, P. Haglund, K. Wiberg, von Holst, A. Maquet, A.-L. Pasini, D. Fraise, G. Becher, P. Korytar, P. Leonards and J. de Boer

Commissioned by: European Community
'Competitive and Sustainable Growth' Programme (1998-2002)
Brussels
Belgium

Project number: 3.41.12260.04

Contract number: G6RD-CTR-2001-000572

Approved by: Prof. dr. J. de Boer
Head of Environment and Food Safety

Signature: _____

Date: May 2005

Number of copies:	5
Number of pages:	75
Number of tables:	21
Number of figures:	26
Number of annexes:	45

Since the first of June 1999 the foundation DLO (Agricultural Research Department) is no longer part of the Ministry of Agriculture, Nature and Food Quality. We are registered in trade register of the Chamber of Commerce Amsterdam no. 34135929 VAT no. NL 811383696B04.

The management of the RIVO-Netherlands Institute for Fisheries Research accepts no responsibility for the follow-up damage as well as detriment originating from the application of operational results, or other data acquired from the RIVO-Netherlands Institute for Fisheries Research from third party risks in connection with this application.

This report is drafted at the request of the commissioner indicated above and is his property. Nothing from this report may be reproduced and/or published by print, photoprint microfilm or any other means without the previous written consent from the commissioner of the study.

FINAL TECHNICAL REPORT**CONTRACT N° : G6RD-CT-2001-00623****PROJECT N° : GRD1-2001-40002****ACRONYM : DIFFERENCE****TITLE : Dioxins in Food and Feed – Reference Methods and New Certified Reference Materials****PROJECT CO-ORDINATOR : dr. J. de Boer (RIVO)****PARTNERS :**

**Netherlands Institute for Fisheries Research
Scientific Institute of Public Health
Centre Analyses et Recherche de Substances Organiques
Flemish Institute for Technological Research
Lund University Consejo Superior de Investigaciones Cientificas
State Institute of Quality Control of Agricultural Products
European Commission
Umeå University**

REPORTING PERIOD: FROM 01-02-2002 TO 31-01-2005

PROJECT START DATE : 01-02-2002 DURATION : 36 months**Date of issue of this report : 30-04-2005**

Project funded by the European Community under the 'Competitive and Sustainable Growth' Programme (1998-2002)

Table of Contents

Table of Contents	3
2. Executive publishable summary	5
3. Objectives of the project	9
4. Scientific and Technical description of the results.....	10
4.1 Work package 1: Materials	10
4.1.1 Task 1. Selection of the materials	10
4.1.2 Task 2. Preparation of the materials.....	13
4.1.2.1 Candidate CRMs	14
4.1.2.2. Materials used in WP-3	16
4.1.3 Task 3. Report on the production of the materials.	17
4.1.4 Conclusions.....	18
4.2 Work package 2: Homogeneity and Stability studies	18
4.2.1 Task 4. Homogeneity of 5 candidate CRMs.....	18
4.2.2 Task 5. Stability 5 candidate CRMs.....	19
4.2.3 Task 6. Report homogeneity and stability study	21
4.2.4 Conclusions.....	21
4.3 Work package 3: Method development	22
4.3.1 Task 7. CALUX optimisation.....	22
4.3.2 Task 8. Ah-PCR development and optimisation.....	24
4.3.3 Task 9. GCxGC development and optimisation	24
4.3.4 Task 10. LRMS(/MS) optimisation.....	29
4.3.5 Task 11. HRMS optimisation	34
4.3.6 Task 12. Interlaboratory tests	34
4.3.7 Task 13. Report on performance of developed methods.....	38
4.3.8 Cost evaluation of techniques	38
4.3.9 Conclusions.....	41
4.4 Work package 4: Test certification.....	43
4.4.1 Task 14. Preparation of protocols and T 15 Instruction of participants.....	43
4.4.2 Task 16. Analyses interlaboratory study	43
4.4.3 Task17. Statistical evaluation	43
4.4.3.1 Discussion of the overall performance	43
4.4.3.2 Evaluation of the PCDD/F-TEQ determination by GCxGC-ECD, GC-LRMS/MS and CALUX46	
4.4.3.3 Evaluation of the total TEQ determination	47

4.4.4 Task 18. Evaluation meetings	49
4.4.5 Task 19. Report feasibility certification.....	50
4.4.6 Recommendations for a future certification study	50
4.4.7 Conclusions	50
4.5 Work package 5: Extraction and clean-up methods	51
4.5.1. Design of the study and partners involved.....	51
4.5.2 Task 20. Development and optimization of SFE.	51
4.5.3 Task 21. Development and optimization of MAE.	53
4.5.4 Task 22. Development and optimization of ASE.	54
4.5.5 Conclusion	59
4.6 Work package 6: Standardisation	59
4.6.1 Task 24. Validation protocol	59
4.6.2 Task 25. Standardisation of methods	59
4.6.3 Task 26. Report on standardisation	60
4.6. 4 Conclusions	60
4.7 Work package 7: Dissemination	60
4.7.1 Task 27. Scientific publications, platform presentations and posters.....	61
4.7.2 Task 28. Workshop	65
4.7.3 Task 29. Video/DVD preparation	66
4.7.4 Task 31. Training course.....	66
4.7.5 Task 31. Web-site	67
4.7.6 Task 32. Other exploitation activities	67
4.7.7 Conclusions	67
4.8 Work package 8: Coordination	68
4.8.1 Task 33. Technological Implementation Plan.....	68
4.8.2 Task 34. Final report.....	68
4.8.3 Task 35. Management	68
5. List of deliverables	69
6. Comparison of initially planned activities and work actually accomplished	71
7. Management and co-ordination aspects	72
8. Results and Conclusions	72
9. Acknowledgements	72
10. References	72
Annexes overview.....	74
Annexes overview.....	74

2. Executive publishable summary

The European research project DIFFERENCE (“Dioxins in Food and Feed – Reference methods and New Certified Reference Materials”) was focussed on the development of an alternative methods for analysis of polychlorinated dibenzodioxins (PCDDs), dibenzofurans (PCDFs) and dioxin-like polychlorinated biphenyls (dl-PCBs) using comprehensive multi-dimensional gas chromatography (GC×GC), gas chromatography combined with low resolution ion-trap mass spectrometry (GC-LRMS/MS), the CALUX bioassay and an Ah-PCR technique. GC combined with high resolution mass spectrometry (HRMS) was used as a reference method in all comparisons. Given the need for a regular monitoring of PCDD/Fs and PCBs in Europe, which was further enhanced by the implementation of the maximum residue values for PCDD/Fs in food and animal feed per 1 July 2002, and the relatively high costs of GC-HRMS instrumentation and the limited capacity for HRMS analyses in European laboratories, cheaper, faster, but reliable methods are badly needed. The method development part included a developmental phase, a validation phase and a standardisation phase. In addition to the method development, attention was also paid to alternative extraction and clean-up methods. Finally, the DIFFERENCE project also included a feasibility study on the preparation and certification of five reference materials. This part was included because no certified reference materials (CRMs) exist at the moment that cover all PCBs, PCDDs and PCDFs included in the European legislation.

More specifically, the above mentioned objectives can be subdivided in:

1. Identification and selection of food and feed matrices in view of dioxin/PCB contamination and description of these matrices for use as test materials
2. Assessment of the feasibility of the preparation of these materials as CRMs by the preparation of test batches, including homogeneity and stability studies
3. Assessment of the measurement capability and quality of laboratories to certify the candidate CRMs
4. Optimisation of bio-analytical and chemical screening methods for dioxin and PCB analysis.
The methods included are:
 - a) GC×GC-ECD (or MS)
 - b) GC – LR MS(/MS)
 - c) CALUX bioassay
 - d) Ah-PCR assay
5. Validation and standardisation of the developed and optimised screening methods, including the extraction and clean-up methods
6. Development, optimisation and validation of extraction and clean-up methods for dioxin and PCB analysis and combination of these methods with the developed screening methods or with a GC-HRMS method. The methods included are:
 - a) Accelerated Solvent Extraction (ASE)
 - b) Microwave Assisted Extraction (MAE)
 - c) Supercritical Fluid Extraction (SFE)

Furthermore, the dissemination of the results is an important objective in order to inform the scientific audience as well as policy makers on the results of the project.

The objectives are translated into specific tasks, deliverables and milestones. The results will be discussed task by task in the next chapter.

The DIFFERENCE project was split into seven workpackages (WPs):

- 1) Selection of test materials
- 2) Homogeneity and stability tests
- 3) Development and validation of alternative methods
- 4) Feasibility study on preparation and certification of reference materials
- 5) Development of alternative extraction and clean-up methods
- 6) Standardisation of the developed alternative methods
- 7) Dissemination of results and coordination

Selection of test materials (WP 1)

WP1 was split into three tasks:

- 1) Selection of test materials

- 2) Preparation of these materials
- 3) Report on the preparation

The selected materials for the feasibility study on certification were: a fish tissue (herring), pork, milk, fish oil and a compound feed. The first three materials were canned, the fish oil was ampouled and the compound feed was packed in plastic screw-cap jars. In addition, a large number of test materials for WP3 including a series of PCB and PCDD/F standard solutions, blanks, and solutions with possible interfering compounds were prepared.

Homogeneity and stability tests (WP 2)

The homogeneity and stability tests revealed no specific problems that could hinder the certification of reference materials for the PCBs and PCDD/Fs which are currently included in the European legislation for food and feed. All preparations went smoothly. Some homogeneity problems were identified for the canned milk. These can be solved by using a milk powder instead of canned milk as a candidate CRM.

Development and validation of alternative methods (WP 3)

The strategy of the DIFFERENCE project was to start from four different alternative techniques for the determination of dl-PCBs and PCDD/Fs, hoping that at least one of them would turn out to be suitable to serve as an alternative method for GC-HRMS. That technique should then be combined with the improved extraction and clean-up to speed up the analysis and further reduce analysis costs in that way. The results of WP 3 have surpassed the expectations. Three out of the four methods have successfully been developed and validated.

CALUX may be considered as a valuable screening method that can be used in times of crisis for a large number of samples to indicate if those samples are below, around of above the EU MRLs. A correction for recovery is essential to obtain reliable results. Quantitative total-TEQ values may also be produced by this method, but due to the variability of those data the use of CALUX in that way is not recommended at the current MRLs and action limits. When considering *only* PCDD/Fs and non-ortho PCBs the quantitative data produced by CALUX are of better quality. If a fractionation of the extracts, resulting in a PCDD/F + non-ortho PCB fraction, a mono-ortho PCB fraction and a bulk PCB fraction is applied, a CALUX analysis of the PCDD/F + mono-ortho PCB fraction may result in reproducible quantitative data. However, CALUX results of mono-ortho PCBs have a too high variability.

GC-LRMS/MS may be used as a reliable routine method that will produce congener-specific data. Excellent results have been achieved in the various interlaboratory studies and the feasibility study on certification. However, a few critical observations have to be made. During the project basically one laboratory has worked on this technique. The results were very good, but until now they have not been confirmed by other laboratories. It may well be that only the specific type of GC-MS/MS used produces good results whereas other types may not deliver such results. Further investigations are needed in this field. Furthermore, a highly experienced operator is needed to ensure good results and the maintenance of the MS and particularly of the ion-source may be time-consuming because frequent cleaning of the ion-source may be required regularly.

Finally, GCxGC-ECD or GCxGC-ToF-MS emerged as another viable routine method for dl-PCBs and PCDD/F measurement. No doubt for environmental samples, and for food and feed materials in which dioxins and dl-PCBs occur at higher concentrations (around or above the MRLs in fatty fish, fish oil), GCxGC is able to serve as an excellent routine method and alternative for HRMS. When dioxin and dl-PCB concentrations occur at low levels, i.e. lower than the MRLs and action levels, or in low fat samples such as fish, compound feeds, and meat, it may still serve as a screening method. However, a lot of time is needed to integrate the chromatograms, adjusting the baseline, comparing relative retention times, etc. Better software will help to speed up these processes at lower concentrations, but some identification problems may remain in the near future for relatively clean materials. GCxGC-ToF-MS is not so much more sensitive than GCxGC-ECD. However, the peak shapes are better because the peaks do not suffer from the relatively large cell volume of the micro-ECD that causes peak tailing, and the additional information from the mass spectra helps to identify the target compounds at low concentrations. In that sense, GCxGC-ToF-MS is an improvement compared to GCxGC-ECD, but obviously the instrument is considerably more expensive. The work on GCxGC has created a lot of off-spin from this project. In addition to the application for dioxin analysis, this technique can be used in many applications in which complex mixtures need to be analysed. Excellent chromatograms have been achieved for other contaminant mixtures such as toxaphene, chlorinated paraffins, polychlorinated naphthalenes, brominated flame retardants and many others. Also, these contaminants can be separated from each other enabling a multi-component analysis. In

that way GCxGC is invaluable. It is expected that many environmental and food-safety laboratories in Europe and world-wide will implement this technique in their methods. Other applications of GCxGC have been seen in the oil industry and e.g. in the separation of fatty acids.

Apart from a judgement on the scientific quality of the results of the alternative methods, DIFFERENCE has also addressed the economical aspects of the methods. An evaluation of costs of investment, manpower, analysis time etc. has been made for all methods developed including the new extraction and clean-up techniques. The most important observations are: i) A major gain in time and costs is achieved by the application of the ASE technique in combination with a fat retainer, and, possibly, in combination with a small carbon cell. This approach saves 2-3 days work of a technician per series of 10-15 samples. It can be used in combination with GC-HRMS, GCxGC-ECD or -ToF-MS, GC-LRMS/MS, and CALUX; ii) In times of crises with many samples to be screened for the presence of dioxins and/or dl-PCBs CALUX is a rapid and useful method which cannot be beaten at the moment by any other method. However, it is not recommended to use CALUX for quantitative purposes (unless for PCDD/Fs only), but just to detect dioxins and/or dl-PCBs around or above the MRLs or to confirm the absence of these contaminants; iii) GC-LRMS/MS is much cheaper than GC-HRMS in investment in instrumentation and in maintenance costs; there is not so much reduction of man hours compared to GC-HRMS; iv) also, GCxGC-ECD is considerably cheaper in investment in instrumentation than GC-HRMS. However, for low level samples the time needed for the interpretation of the chromatograms is, for the time being, considerably longer than in GC-HRMS. Better software may help to reduce the amount of time needed. For environmental samples, and for more fatty food and feed samples with concentrations at levels around the MRLs or higher, this method is excellent. GCxGC-ToF-MS is a proper alternative that delivers more structural information. However, the instrument costs are relatively high, although not as high as that of a GC-HRMS.

A screening fourth method that was studied, was based on an Ah-PCR analysis. It was taken into consideration at a point where the project had already started, and is still under development. It is not excluded that this technique may finally also result in a suitable alternative screening method. The research on this technique was further delayed by managerial problems, such as the move of the partner's laboratory during the first phase of the project.

Feasibility study on the preparation and certification of materials for PCBs and PCDD/Fs (WP 4)

The certification feasibility included a lot of work for the fifteen participating laboratories, but resulted in good perspectives for a final certification. This part of the project also showed that it was possible to use the alternative techniques GC-LRMS/MS and GCxGC-ECD for certification, in addition to GC-HRMS. It is hoped that European funds will now be made available through the IRMM to prepare and certify the planned CRMs.

Alternative extraction and clean-up methods (WP5)

The WP on alternative extraction and clean-up methods has focussed on the development of pressurized liquid extraction (PLE), also called accelerated solvent extraction (ASE). It appeared that this technique is to be preferred to supercritical fluid extraction (SFE) and microwave assisted extraction (MAE). In particular the addition of a fat retainer to the extraction cell is a major step forward because in that way one or more clean-up steps have become redundant and valuable technician time is gained. A further improvement is the inclusion of a carbon column into the extraction cell. The planar target compounds (non-ortho PCBs and PCDD/Fs) are eluted from the carbon column by back flushing. In that way it is even possible to do the extraction within about 15 minutes, concentrate the extract and, without any further clean-up go to the GC/MS, GCxGC or CALUX assay for analysis of the extract. Per series of 10-15 samples, this saves about 3 days work of a technician. The gain in time achieved in this way is considered as the most successful result of this project.

Standardisation (WP6)

The WP on standardisation of the developed methods was planned at the end of the DIFFERENCE project. This part could not be finalised within the time-frame of the project, as was foreseen already in the project planning phase. The activities that have been carried out already are the collection of data, method descriptions, and conditions, and of results of interlaboratory studies carried out within DIFFERENCE. Also, contacts have been made with the CEN, technical working group 275. CEN has responded positively on the proposal to standardize the developed methods, as well as the reference method (GC-HRMS). However, due to the substantial variation in the results of the CALUX assay, it may be difficult to standardise this assay within CEN. Further work on the standardisation

will be carried out in the near future within CEN. This will possibly require considerable efforts on a voluntary basis by the DIFFERENCE participants. It would, therefore, be convenient to find funding for those activities, e.g. through a follow-up of DIFFERENCE to ensure the finalisation of this part of the work.

Dissemination and coordination (WP7)

The DIFFERENCE group has worked together as a very good team. A combined DIAC and DIFFERENCE website was set up (<http://www.dioxins.nl>). The web-site was regularly visited (on average 1,000 hits per month). In collaboration with the DIAC project four newsletters were prepared and distributed world-wide to more than 1,000 addresses.

A large number of scientific papers have been published or are in press or submitted. Special issues of *Talanta* (2004) and *Trends Anal. Chem.* (2005 or 2006) have been or will be devoted to the DIFFERENCE project. Many presentations have been given by the various partners and the coordinator, in particular at the Dioxin symposia in Boston (2003), Berlin (2004) and will be given in Toronto (2005). In January 2005 a final workshop was successfully organized in Brussels. Two training courses on CALUX and GCxGC have been given to representatives of other European laboratories.

Conclusions

The DIFFERENCE project was born at a time when GC-HRMS was the only available technique for dioxin analysis. The CALUX assay was available as a not very well validated screening technique. GCxGC was very much in its infancy and LRMS did not seem to be suitable due to its low sensitivity, in particular for 2,3,7,8-TCDD. Extraction and clean-up were all done in the traditional way. Now, almost five years later, there exists a much faster, reliable extraction and clean-up method, there is a validated CALUX screening method, and there are two methods that can be used as a routine method for PCDD/Fs and dl-PCB analysis: GCxGC and GC-LRMS. Finally there is a good basis for the certification of reference materials of food and feed materials for the analysis of PCDD/Fs, and dl-PCBs included in the European MRLs for food and feed in five different materials, and a standardisation process within CEN will be started for the two routine methods as well as for GC-HRMS. As mentioned above, these results have surpassed the expectations.

Nevertheless, a number of critical remarks should be made as well. GCxGC-ECD has proven to be a useful method, but is still time-consuming when used for samples with low levels of dioxins and dl-PCBs. Further work on software development and on improvement of the sensitivity will be needed. GCxGC-ToF-MS is a better alternative, but much more expensive. GC-LRMS/MS has produced very good results in this project, but basically only one laboratory has worked on this method. It should be investigated if the method is robust enough when used in other laboratories and if other brands of instruments would meet the same standards. For several reasons time was too short to develop the Ah-PCR technique sufficiently as an alternative to the CALUX assay. More time is needed to study and improve this alternative, which is promising provided the effect of interferences can be reduced. Over the last five years other assays or techniques for contaminant or toxin analysis have been developed. Some of these seem to have enough potential to serve as an alternative rapid method for dioxin analysis. It may be worthwhile to test a selection of those new techniques. The standardisation process within CEN will require a considerable amount of time and efforts from the DIFFERENCE partners. If no funds are raised for this work, it would have to be done on a voluntary basis, making the process rather vulnerable. There are five candidate CRMs, but presently, funding seems to be lacking to initiate their final production and certification. If this situation would remain, a great part of the R&D of this project would be in vain and valuable tax money would be wasted. Finally, there is a clear need for training of European laboratory staff in the new techniques. There is a particular interest in that in the new EU member states. All together there seems to be enough arguments to justify a continuation of this successful project for another period of ca. 3 years.

3. Objectives of the project

There are two main objectives in the DIFFERENCE project, which are i) the development, optimisation and validation of **alternative methods for dioxin analysis** which allow a reliable, simple and low-cost determination of dioxins and (dioxin-like) PCBs. This includes the optimisation and validation of new extraction and clean-up procedures that enable rapid and simple extraction and clean-up of samples, and ii)

the **feasibility testing of the production and certification of five high quality certified reference materials** for dioxins, furans, dioxin-like PCBs and indicator PCBs in food and animal feed.

More specifically, the above mentioned objectives can be subdivided in:

7. Identification and selection of food and feed matrices in view of dioxin/PCB contamination and description of these matrices for the purpose of:
8. Assessment of the feasibility of the preparation of these materials as CRMs by the preparation of test batches, including homogeneity and stability studies
9. Assessment of the measurement capability and quality of laboratories to certify the candidate CRMs
10. Optimisation of bio-analytical and chemical screening methods for dioxin and PCB analysis. The methods included are:
 - a) GCxGC-ECD (or MS)
 - b) GC – Low Resolution MS(/MS) (GC-LRMS/MS)
 - c) CALUX bioassay
 - d) Ah-PCR assay
11. Validation and standardisation of the developed and optimised screening methods, including the extraction and clean-up methods
12. Development, optimisation and validation of extraction and clean-up methods for dioxin and PCB analysis and combination of these methods with the developed screening methods or with a GC-HRMS method. The methods included are:
 - a) Accelerated Solvent Extraction (ASE),
 - b) Microwave Assisted Extraction (MAE),
 - c) Supercritical Fluid Extraction (SFE)

Furthermore, the dissemination of the results is an important objective in order to inform the scientific audience as well as policy makers on the results of the project. Dissemination of the knowledge built-up in the project takes place by publications in international journals and presentations at international symposia and via a web-site. In addition, dissemination takes place through a workshop in collaboration with the DIAC project to inform potential users about the results of the project. A film has been produced for dissemination of the project's results to the scientific community and policy makers. Finally, in collaboration with the DIAC project, representatives from European food control laboratories have been invited to get a 'hands-on' training for the analyses of dioxins with the new developed techniques.

The objectives are translated into specific tasks, deliverables and milestones. The results will be discussed task by task in the next chapter. An overview of the deliverables and milestones can be found in Annex 1. WP-8 **Minutes of kick-off meeting**

4. Scientific and Technical description of the results

Overview of the technical state of research and comparison of achieved and stated objectives

The focus in the first year was on the preparation of the materials for WPs-2, 3 and 4. Furthermore, a main goal was to develop and optimise the screening methods for the analysis of dioxins and dl-PCBs. The chemo-analytical techniques focussed on the detection and quantification of the seventeen 2,3,7,8-substituted PCDD/Fs and twelve dioxin-like PCBs (Table 1), to enable the calculation of the TCDD Toxic Equivalency (TEQ) value required by current and future European legislation. The bio-analytical techniques focused on the selective detection of the total-TEQ value and the reduction of the influence of other co-extracted compounds on the total-TEQ detection. Furthermore, three extraction techniques were optimized for the extraction of dioxins and dl-PCBs from various food and feed matrices.

The focus in the second year was on the evaluation of i) validation of the screening methods and a selected extraction method for analysis of dioxins and dl-PCBs according to a detailed validation protocol (WP-3) and ii) the homogeneity and stability study of the candidate CRMs.

The third year focused on the test certification of the candidate CRMs, the finalization of the stability study and dissemination of the results obtained in the project by means of a film, by scientific publications, standardization of protocols and by the organization of a training and workshop.

The following paragraphs describe the design of the study, the partners involved, the results and discussion, conclusions, and milestones and deliverables for each work package and task.

Table 1. Studied PCDD/Fs and PCBs

PCDDs	PCDFs	dioxin-like PCBs
2,3,7,8-TCDD	2,3,7,8-TCDF	3,3',4,4'-TCB
1,2,3,7,8-PcCDD	1,2,3,7,8-PcCDF	3,4,4',5'-TCB
1,2,3,4,7,8-HxCDD	2,3,4,7,8-PcCDF	3,3',4,4',5'-PeCB
1,2,3,6,7,8-HxCDD	1,2,3,4,7,8-HxCDF	3,3',4,4',5,5'-HxCB
1,2,3,7,8,9-HxCDD	1,2,3,6,7,8-HxCDF	2,3,3',4,4'-PeCB
1,2,3,4,6,7,8-HpCDD	2,3,4,6,7,8-HxCDF	2,3,4,4',5'-PeCB
OCDD	1,2,3,7,8,9-HxCDF	2,3,4,4',5'-PeCB
	1,2,3,4,6,7,8-HpCDF	2',3,4,4',5'-PeCB
	1,2,3,4,7,8,9-HpCDF	2,3,3',4,4',5'-HxCB
	OCDF	2,3,3',4,4',5'-HxB
		2,3',4,4',5,5'-HxCB
		2,3,3',4,4',5,5'-HpCB

4.1 Work package 1: Materials

The objective of WP 1 is the preparation of suitable materials which have been used in the rest of the study. The WP can be sub-divided in two parts: i) the preparation of five test materials which served in the feasibility study on the certification (WP 4), and ii) the selection and preparation of a number of other test materials which have been used in WP 3 for the development and optimisation of the screening methods and in WP 5 for the optimisation of the extraction and clean-up techniques. In addition, a number of standard solutions of dioxins, dl-PCBs and indicator PCBs have been prepared to be used in the WPs 3, 4 and 5. This work package is split into three tasks: Task 1. Selection of the required materials, Task 2 the preparation of the materials, and T3 the preparation of a report on the materials.

4.1.1 Task 1. Selection of the materials

The kick-off meeting was held at the Holiday Inn Seaport Beach hotel in IJmuiden at 4-7 February 2002. During that meeting, the EU representatives Dr. F. Verstraete, H&CP DG, EU, Brussels, Belgium and Dr. S. Bøwadt, M&T research DG, EU, Brussels, Belgium provided information on the background of the call for this specific proposal. The work programme and planning of the project were discussed and agreed upon.

During the discussion of WP-1 the requirements of the materials was discussed including availability through the partners. A scheme with selected materials for WP-2/4 and WP-3 were produced and included in the minutes of the kick-off meeting (Annex 1) and are given below in the Table 2 and

Table 3.

Table 2. Details of the WP-2/4 candidate CRMs

Candidate CRMs	Volume (ml) or mass (g)	Concentration range	Preparation and packaging
Milk (powder)	Container of 250-500 ml (at least 10 g fat)	2-3 pg PCDD/F-TEQ/g fat	NIZO*
Pork	Tin of ca. 70 gram	Ca. 1 pg PCDD/F-TEQ/g fat. Ca. 200 µg/kg Σ indicator PCBs	ID**, feed experiment (packing by RIVO)
Fish (herring or salmon)	Tin of ca. 70 gram	Ca. 4 pg PCDD/F+PCB-TEQ/g product	RIVO
Fish oil	Ampoule of ca. 5 ml	Ca. 5 pg PCDD/F+PCB -TEQ/g fat	Nutreco (packing by RIVO)
Compound based feed	Glass jar of ca. 100 g	Ca. 0.5 pg PCDD/F-TEQ/g product (upperbound)	Nutreco

* NIZO: Netherlands Institute for Dairy Research

** ID: Institute for Animal Health

Table 3. Materials used in round 1 to 3 for the evaluation of the screening techniques (WP-3).

Material number	Container	Material	Volume/weight	Solvent
1	Ampoule	Blank solvent	1 ml	DMSO
2	Ampoule	Standard 2,3,7,8-TCDD: 0.04 ng-TEQ/ml	1 ml	DMSO
3	Ampoule	Standard 2,3,7,8-TCDD: 0.1 ng-TEQ/ml	1 ml	DMSO
4	Ampoule	Standard 2,3,7,8-TCDD: 0.4 ng-TEQ/ml	1 ml	DMSO
5	Ampoule	Standard 2,3,7,8-TCDD: 1.6 ng-TEQ/ml	1 ml	DMSO
6	Ampoule	Standard 2,3,7,8-TCDD: 6.25 ng-TEQ/ml	1 ml	DMSO
7	Ampoule	Blank solvent	1 ml	nonane
8	Ampoule	Standard 2,3,7,8-TCDD: 0.1 ng-TEQ/ml	1 ml	nonane
9	Ampoule	Standard 2,3,7,8-TCDD: 0.5 ng-TEQ/ml	1 ml	nonane
10	Ampoule	Standard 2,3,7,8-TCDD: 5 ng-TEQ/ml	1 ml	nonane
11	Ampoule	Standard 2,3,7,8-TCDD: 50 ng-TEQ/ml	1 ml	nonane
12	Ampoule	Standard 2,3,7,8-TCDD: 100 ng-TEQ/ml	1 ml	nonane
13	Ampoule	Standard 2,3,7,8-TCDD: 200 ng-TEQ/ml	1 ml	nonane
14	Ampoule	Quality Control Sample (QCS), 3 pg dioxin and 3 pg PCB-TEQ/g oil	5g	veg. oil
15	Glass jar	Milk sample	250 ml	na
16	Ampoule	Fish oil (herring, close to 4 pg dioxin-TEQ/g oil)	7 ml	na
17	Ampoule	Clean fish extract of fatty fish (fat removed), equivalent of 5 g fat intake	5ml	Pentane
18	Ampoule	Blank vegetable oil	5g	veg. oil
19	Ampoule	Veg. oil + 0.2 pg dioxin- and 0.2 pg PCB-TEQ/g oil	5g	veg. oil
20	Ampoule	Veg. oil + 0.75 pg dioxin- and 0.75 pg PCB-TEQ/g oil	5g	veg. oil
21	Ampoule	Veg. oil + 1.5 pg dioxin- and 1.5 pg PCB-TEQ/g oil	5g	veg. oil
22	Ampoule	Veg. oil + 3.0 pg dioxin- and 3.0 pg PCB-TEQ/g oil (QC-OIL)	5g	veg. oil
23	Ampoule	Veg. oil + 6.0 pg dioxin- and 6.0 pg PCB-TEQ/g oil	5g	veg. oil
24	Ampoule	Veg. oil (see mat. 22) + PCB-spike (200 ng/g oil)	5g	veg. oil
25	Ampoule	Veg. oil (see mat. 22) + PCN-spike (10 ng/g oil)	5g	veg. oil
26	Ampoule	Veg. oil (see mat. 22) + PCDE-spike (20 ng/g oil)	5g	veg. oil
27	Ampoule	Veg. oil + 3.0 pg dioxin- and 3.0 pg PCB-TEQ/g oil (QCO)	5g	na
28	Tin	Herring tissue	70 g	na
29	Tin	Chicken from RIKILT feed experiment	70g	na
30	Glass jar	Feed additive (Sepiolitic clay)	100 g	na
31	Glass jar	Egg from RIKILT feed experiment	100g	na
32	Tin	Pork tissue	70 g	na
33	Plastic jar	Compound feed from RIKILT feed experiment	100 g	na

The finally selected and produced materials have been reported in a combined report on task T3 Report on the production of test materials and Task 13 Report on performance of developed methods (Annex 6 and Annex 16).

4.1.2 Task 2. Preparation of the materials.

The selection and the preparation of the materials was carried under coordination of the Netherlands Institute for Fisheries Research (RIVO). Two sets of materials had to be prepared: one set candidate certified reference materials (CRMs) to be used in WPs-2 and 4 and one set of materials that would be used for the optimisation and validation of the screening techniques (WP-3 and WP-6).

4.1.2.1 Candidate CRMs

Five candidate CRMs have been prepared,. Fish, pork and milk represent food matrices whereas fish oil and feed represent feed ingredients and feed matrices. The target level of dioxins in these candidate CRMs was chosen at the MRLs laid down in the EC regulations on food and feed (EC 2001; EC 2001). For dl-PCBs, the target level (relative to the target level of dioxins) was based on data from either literature or results from monitoring programmes. The levels are shown in Table 4.

Table 4. Target levels of dioxins, dl-PCBs and indicator PCBs in the candidate CRMs

Code	Material	Dioxins (pg TEQ/g fat)	dl-PCBs (pg TEQ/g fat)	Ind.-PCBs
DIFF-01	Fish	4*	4*	background
DIFF-02	Pork	1	0.5	200 µg/g fat
DIFF-03	Milk	3	3	background
DIFF-04	Fish oil	6	6	background
DIFF-05	Feed	0.75*	0.75*	background

* pg TEQ/g ww

DIFF-01 (Herring)

The preparation of the herring material was carried out by RIVO. Herring originating from the North Sea (52.30 N, 02.00 E) was filleted until sixty kilograms of herring fillet remained. The fillets were frozen until further treatment. After de-freezing, the complete volume of meat from herring was minced using a mincer (Finis Machinefabriek, Ulf) in combination with a Fryma mill equipped with toothed rotary knives (Fryma Maschinen AG, Rheinfelden, Switzerland) to a final size of 3.5 mm². Two batches of ca. 25 kg herring mince were separately frozen for further treatment. Subsequently, batches of ca. 25 kg sample were homogenised for three minutes, after adding 0.02% butylhydroxytoluene (BHT), in a Stephan cutter (Stephan Machines, Almelo, The Netherlands), type UMM/SK25 (made in 1979). Coated tins (Eurocan Food, Mechelen, Belgium, volume ca. 75 ml) were filled to the brim with herring homogenate (ca. 65 grams) using a manual dosing machine (machinenfabrik Engler, Vienna, Switzerland). The tins were sealed by a Lanico TVM 335 sealing machine (Thomassen and Drijver, Deventer, The Netherlands). The tins were sterilised in a Muvero-Mat sterilizer (type 90E) for 45 minutes at 122 °C (pressure 1.4 bar, heating-time: 90 minutes, cooling time: 20 minutes). The homogenisation, tinning and sterilisation of the two batches took place at 16 and 25 April 2002. Ca. 600 tins of wet sterilised material are produced. The tins have been stored at RIVO at room temperature until dispatch to subsequent users (WP 2 and 4).

DIFF-02 (Pork)

Contaminated pork meat was not available from a stock and therefore it was decided to conduct a feeding experiment with contaminated feed. For this purpose, feed has been contaminated with spiked vegetable oil (spiked with dioxins, dl-PCBs and the indicator PCBs). The congener profile in the spiked oil was obtained from pork samples from a Dutch routine monitoring program on pork fat. The feeding experiment was conducted at the Institute for Animal Science and Health (ID-Lelystad, Lelystad, The Netherlands). Two pigs of ca. 70 kg each were fed during one week with 28 kg of regular pig feed to which 93.8 g of contaminated oil was added. After one week, the weight increased to 75.6 and 75.8 kg, resulting in 43.6 and 43.8 kg mixture of meat, fat and skin. The fat has been analysed by RIKILT and contained 15 pg-dioxin-TEQ/g fat and 6.7 pg PCB-TEQ/g. As the target level was 1 pg dioxin-TEQ/g fat, the contaminated pork has been diluted 15 times (on a fat weight basis) with regular non-contaminated pork meat from a butcher. The pork homogenate has been tinned and sterilised following the procedure mentioned above for the herring sample. The tins have been stored at RIVO at room temperature until dispatch to subsequent users (WPs 2 and 4).

DIFF-03 (Milk)

Contaminated milk with dioxins at a target level of 3 pg dioxin-TEQ/g fat (MRL) was not available in France, Belgium or The Netherlands because generally background levels are 2-5 fold below the MRL. Therefore, it was decided to spike a milk sample with dioxins and dl-PCBs using a congener profile obtained from a Dutch routine monitoring programme. It was assumed that the milk contained 0.6 pg dioxin-TEQ/g fat (Dutch background level). The spiked amount was 2.4 pg dioxin-TEQ/g fat to obtain a concentration at MRL level. dl-PCBs were spiked at the same concentrations.

At the kick-off meeting it was agreed to try to produce tins of sterilised whole milk instead of milk powder as the first approach resemble every day routine the best. Until now there was no evidence that sterilised whole milk samples would remain biologically and physically stable for a long period

(>5 years). The results of the stability test (WP-2) should show if this approach would be feasible. If the milk would not be stable, the alternative approach would be to produce milk powder instead of sterilised milk as had been proved by the CRMs BCR 188, 533 and 534 (pesticides and dioxins in milk powder).

The production of the milk sample was carried out at 5 September 2002 in the pilot plant of a subcontractor (NIZO Food Research, Ede, The Netherlands). The whole milk was pasteurised using 74 °C on a APV pasteuriser for 10 seconds. The contaminants were added to 100 kg of the milk and after 20 min of stirring, the milk was again pasteurised on a Stork tube pasteuriser at 74°C for 10 seconds. Subsequently, the milk was homogenised at 200 bar and 50°C using an M.G. homogenisator. Ca. 75 kg of milk was used to fill the tins of 150 ml manually with 100 g milk. The sterilisation of the first batch of closed tins took place at 122+/-°C (monitored with a thermocouple) for 20 minutes at 11 rotations per minute in a Stock sterilisator. Due to a headspace of ca. 50 ml in the closed tins, the tins imploded during the sterilisation process resulting in the loss of the first batch. Therefore, it was decided to fill the remaining tins with 150 g milk. The sterilisation under the same conditions was completed without any problem.

The subcontractor performed a stability test by storing the sterilised milk at 30°C for 7 days. After this period, bacterial growth on a PCMA plate (plate milk count agar) was determined after 3 days of incubation. No microbiological growth was found and therefore the samples are sterile. The tins were stored at 4°C at RIVO until dispatch to subsequent users (WPs 2 and 4).

Table 5.Characteristics of milk prior to sterilisation

Lipid content (%)	Protein content (%)	Lactose content (%)	Enterobacteriaceae count (Kve/ml)	Total bacterial count (Kve/ml)
4.00	3.39	4.43	<10	<10

DIFF-04 (Fish oil)

The fish oil sample was produced from a crude fish oil sample which was obtained as a remainder of a project on the upgrading herring by-products (Aidos, van de Padt et al. 2001). The herring was caught in June 1999, West of the Shetland Islands (60.40° N/03.00 W). The oil was filtered over 0.45 µm paper filter (Schleicher & Schuell) to remove solid particles. After decapping by the flame of a gas burner, the amber coloured ampoules were filled with fish oil using a HIRSCHMANN Laborette 2-10 ml dispenser. While filling the ampoules, the fish oil was heated to 40°C and constantly stirred to homogenise the oil and to prevent crystallisation of the larger triglycerides. The ampoules were closed directly after filling by flame sealing. After closing the ampoules, the weight was determined and written on the label in order to trace possible losses oils due to leaks in the glass. The ampoules were stored at RIVO at room temperature until dispatch to subsequent users (WPs 2 and 4).

DIFF-05 (Compound feed)

Compound feed was prepared by a subcontractor (Nutreco Maasweide Laboratory Services, Boxmeer, The Netherlands). Salmon oil was chosen as the lipid source in the compound feed.

The salmon oil was obtained from an oil trading company (A. Smit & Zoon bv., Amersfoort, The Netherlands) and contained dioxins at a level of 3.24 pg TEQ/g oil. The target level in the feed 0.75 pg dioxin-TEQ/g ww. Therefore, the fish oil needed to be spiked with additional dioxins (6.76 pg TEQ/g fat) up to a level of 10 pg/g fat. The dl-PCBs were spiked with the same amount. At 12 July 2002, 200 kg of a typical pig feed was prepared. The fat content was adjusted from normally 1% to 5.5% in order to introduce sufficient fat and contaminants in the feed. The following ingredients were mixed in relative amounts: barley (0.8%); wheat bran sharps (3.0%); wheat gluten feed meal (10.0%); soya oil cake 48 (15.9%); palm pernel flakes (6.0%); canola grist RE<38 (12.0%); tapioca 66 (40%); beet pulp <10 sui (4%), spiked salmon oil (5.5%); chalk 1 (0.6%); mixing salt 1 (0.2%); lysine 1 (0.3%); vitamin mix pig-37 (0.2%) and melasse (2.0%). After thorough mixing of the ingredients, the feed homogenate was pelleted at 1.2 bar at a pellet size of 3.5 mm. The feed was packed in plastic containers (container of polyvinylchloride, cap of polypropylene and white inlay of polyethylene foam) at amounts of 140 gram per container. The subcontractor determined the moisture and fat content in 5 containers of the complete batch. The fat content was 6.5±0.08% and the moisture content was 10.6±0.08%, which indicates that the feed is homogeneous. However, the homogeneity was also determined by analysing dioxins, dl-PCBs and indicator PCBs in WP-2. The fat content is 1% higher than the added amount of fish oil. This will most likely be caused by the extracted traces of lipids from the other ingredients.

Ca. 1700 containers were produced. 600 containers of feed were stored at RIVO at -20°C to prevent possible degradation of the feed, whereas the remaining 1200 containers were stored at

room temperature (due to limited freezer space). The containers required for the homogeneity and stability testing and for the test certification (WP-4) have been taken from the -20°C stock.

4.1.2.2. Materials used in WP-3

For the validation of the screening methods several materials were produced for round 1, 2 and 3 of the validation scheme.

All solvent and oil based materials were ampouled. The amber coloured ampoules (Nederlandse Ampullen Fabriek, Nijmegen, The Netherlands) were used without prior cleaning, which has been demonstrated to be a safe approach for PCBs and other POPs for the QUASIMEME interlaboratory studies (de Boer, van der Meer et al. 1994).

Material 1 is pure DMSO solvent (Acros, Geel, Belgium). Materials 2 to 6 have been produced by diluting gravimetrically a standard of 2,3,7,8-TCDD in DMSO (Cambridge Isotope Laboratories, Andover, MA, USA) with DMSO. Material 7 is pure nonane (Merck, Darmstadt, Germany). Materials 8 to 13 have been produced by diluting gravimetrically a standard of 2,3,7,8-TCDD (Wellington, Guelph, Ontario, Canada) with nonane.

Material 14 is a vegetable oil (corn oil) which has been purchased in a local super market in the Netherlands (Deka Markt, IJmuiden). Prior to spiking, the levels of dioxins and dl-PCBs have been determined in the oil by RIKILT – Institute for Food Safety, Wageningen, The Netherlands. The spiking profile was based on a profile of PCDD/Fs and dl-PCBs in herring. A commercial mixture containing all WHO dioxins and furans was used and additionally 2,3,4,7,8-PeCDF, 1,2,3,4,6,7,8-HpCDF, OCDF, 1,2,3,4,6,7,8-HpCDD and OCDD (all obtained from Wellington Laboratories, Guelph, Ontario, Canada) were spiked to resemble the herring profile. The non-ortho PCBs (PCB 77, 81, 126 and 169) were all individually spiked and the mono-ortho PCBs were spiked using a standard solution, obtained from RIKILT (containing the PCBs 105, 114, 118, 123, 156, 157, 169 and 189), with additional spiking of PCB 105, 118 and 156 (Ultra Scientific, North Kingstown, RI, USA) Information on the purity of the standards can be found in van Loco et al. (2004). The spiked milk sample (material 15) was produced by spiking dioxin and dl-PCB congeners to 20 litres of sterilized whole milk which had been purchased from a local supermarket in The Netherlands (Deka Markt, IJmuiden). The spiking-profile of the dioxins and dl-PCBs was obtained from Dutch raw milk monitoring data (RIKILT). All 17 WHO congeners were spiked at a basis level using a standard solution containing all congeners (Wellington, Canada). Furthermore, the following individual congeners were added to approach the milk congener profile: 2,3,4,7,8-PeCDF, OCDF, 1,2,3,4,6,7,8-HpCDD, OCDD. The WHO-non-ortho PCBs were spiked from standard solutions of the individual congeners (obtained from RIKILT). The mono-ortho PCBs were spiked using a mixture of these PCBs (RIKILT standard solution). Furthermore, the indicator PCBs (PCB 28, 101, 118, 138, 153 and 180 (all obtained from Ultra Scientific, North Kingstown, RI, USA) had been added to the milk for the homogeneity study. To enable quantification, spiked levels were higher than based monitoring data. Due to this fact, PCB 118 had been added twice: once as a mono-ortho in the RIKILT standard solution and again as an indicator PCB at higher level. Therefore, the second addition resulted in a somewhat unbalanced mono-ortho PCB TEQ and the total TEQ with PCB 118 being the predominant congener (with a concentration of 4.7 pg TEQ/g fat for PCB-118 on a total of 5.1 pg PCB TEQ/g fat). The crude fish oil sample (material 16) was obtained as a remainder of a project on the upgrading herring by-products (e.g. heads) (Aidos 2002). The herring was caught in May 2000, West of the Shetland Islands (60.50° N/03.00 W). The oil was filtered over 0.45 µm paper filter (Schleicher & Schuell, Dassel-Relliehausen, Germany) to remove solid particles and subsequently ampouled.

The clean fish extract (CFE) (material 17) was produced by extracting a pooled eel sample from several Dutch freshwater locations. After extraction, portions of 5 g fat were cleaned over acidic silica columns (48 g silica per column). The solvent was evaporated and the residue was redissolved in n-heptane (Promochem, Wesel, Germany, Picograde purity). 25 ampoules were produced containing 5 ml of clean fish extract (CFE) which is equivalent to 4 g of fat.

The blank vegetable oil (material 18) is of the same origin as material 14 but without spiking the dioxins and the dl-PCBs. The spiked vegetable oils (materials 19-23) were prepared by analogy with material 14. Their spiking levels are given in

Table 3. The materials 24, 25 and 26 have also been prepared from material 14. An in-house standard solution of 29 PCBs (including the mono-ortho PCBs 105, 118 and 156) was spiked to the required level of 200 ng/g oil (material 24). Material 25 was prepared by additional spiking of polychlorinated naphthalene's (PCN) 27, 28, 36, 52, 54, 67, 68, 71, 53, 66, 73 and 74 (Wellington Laboratories, Guelph, Ontario, Canada) to a total level of 10 ng/g oil. Material 26 was prepared by spiking it with a polychlorinated diphenyl ether (PCDE) standard solution (Cambridge Isotope Laboratories, Andover, MA, USA). The standard contained native and ¹³C-labeled mono-decaCDEs at a level of 20 ng/g oil (sum of all PCDEs). The QCO (QCO; material 27) is the completely identical material (from the same batch) as material 14 and 22 from round 1 and 2.

The pork tissue (material 28) was obtained by a pig feeding experiment that was conducted to produce contaminated pork meat. For this purpose, feed was contaminated with spiked vegetable oil (spiked with dioxins, furans, dl-PCBs and the indicator PCBs). The congener profile in the spiked oil was obtained from pork samples from a Dutch routine monitoring program on pork fat. A vegetable oil, spiked with PCDD/Fs (obtained from RIKILT) was diluted to the required concentration using vegetable oil purchased from a local super market (Deka Markt, IJmuiden, The Netherlands). The non-ortho PCB (NO-PCB) were spiked from a commercial standard solution obtained from Wellington Laboratories, Guelph, Ontario, Canada. PCB 77 and 81 were additionally spiked from individual standard solutions to obtain the required profile. The mono ortho PCBs and the indicator PCBs (Ultra Scientific, North Kingstown, RI, USA) were spiked from individual standard solutions. The feeding experiment was conducted at the Institute for Animal Science and Health (ID-Lelystad, Lelystad, The Netherlands). Two pigs of ca. 70 kg each were fed during one week with 28 kg of regular pig feed to which 93.8 g of contaminated oil was added. After one week, the weight increased to 75.6 and 75.8 kg, resulting in 43.6 and 43.8 kg mixture of meat, fat and skin. The fat has been analysed by RIKILT and contained 15 pg dioxin-TEQ/g fat and 6.7 pg PCB-TEQ/g fat. 2.3 kg contaminated meat (containing 12% fat) was mixed with 22.7 kg of normal background contaminated meat (de Noordhollandse vleeshal, Heemskerk, The Netherlands, containing 28.2% fat), resulting in a 25 fold dilution of the contaminated meat (on a fat weight basis). The mincing, homogenization and tinning procedures are performed in the same way as for the DIFF-01 material (see above).

The chicken type materials (materials 29, 31 and 33) were obtained from a chicken feeding experiment (conducted at the Institute for Animal Science and Health, ID-Lelystad, Lelystad, The Netherlands on behalf of RIKILT) in which hens were fed with contaminated feed in order to study the carry-over of PCDD/Fs and dl-PCBs from feed to tissue (fat) and eggs. Details can be found elsewhere (Traag, Kan et al. 2003). Briefly, PCDD/Fs and dl-PCBs were spiked to soy oil. By dilution with 'blank' (background contaminated) soy oil, different levels were obtained which were mixed with the remaining feed ingredients. The naturally contaminated feed was fed to the hens and contaminated eggs were collected during the feeding experiment. The naturally contaminated meat was obtained after slaughtering of the hens during and after the experiment.

For round 3, the homogenized compound feed (material 33) was packed in plastic (PP) 150 ml containers with PP lids. Concerning the egg material (31), a mixture of egg yolk and white was thoroughly homogenized and amber glass bottles were filled with ca 40 ml egg yolk and white homogenate. Alumina foil prevented direct contact between the plastic lid and the material. The samples were stored at -20°C. The extractable fat content (by Soxhlet) of the mixture is 10.1%. Concerning the chicken tissue material (29), after removal of residual feathers and bones, the hen tissue and fat were minced, homogenized and tinned according to the procedure described below. The tins were filled from an icing bag instead of a dosing machine. The extractable fat content (determined by Soxhlet extraction) was 6.3%.

The sepiolite was chosen as a mineral clay which is often applied as a feed additive. Since the caolinitic clay contamination incident, sepiolitic clay replaced caolinitic clay. Four bottles of ca. 0.5 kg of sepiolite were obtained from a commercial production plant (Tolsa S.A., Madrid, Spain). Amber glass 50 ml bottles were filled with ca 45 g of the manually homogenized sepiolite. The bottles were closed with a plastic lid (a piece of alumina foil covered the lid inside to prevent contact between the material and the lid).

The herring tissue (material 32) preparation was carried out by RIVO. Herring originating from the North Sea was filleted until ca 5 kg of herring fillet remained. The fillets were frozen until further treatment. After thawing, the material was minced, homogenized and canned as described earlier (DIFF-01 material).

4.1.3 Task 3. Report on the production of the materials.

The preparation of the materials for WP-2/4 has been reported in the progress report of year 1 (Annex 3). Furthermore, the preparation of the materials has been described in the final report of the

test certification (WP-4) (Annex 4). The preparation of the materials for WP-3 has also been reported in the progress reports of year 1 (Annex 3). Furthermore, the results of WP-3, round 1 and 2 have been reported by J. van Loco (IPH) and S.P.J. van Leeuwen (RIVO), which includes the results on the preparation of the materials (Annex 6) Finally, the results of the preparation of the materials for WP-3, the homogeneity tests of these materials (WP-2) and the validation rounds 1 and 2 of WP-3 have been combined in a scientific publication (Van Loco, Van Leeuwen et al. 2004) in a special volume of *Talanta* (guest editor L. Goeyens, IPH) on the analysis of dioxins and dl-PCBs (Annex 7). The results of WP-3 round 3 and WP-4 will also be submitted for scientific publication, including the details on the preparation of the materials (WP-1).

4.1.4 Conclusions

The materials for WP-3 and WP-5 as well as for WP-2 and 4 have been produced by RIVO and sub-contractors. The materials have successfully been applied in the WP's mentioned above. The results of WP-2 round 1 and 2 have been reported in progress reports, separate reports and in a scientific publication. Two scientific publications will be submitted which will include the results of WP-1.

Partners involved

RIVO was the coordinator of this WP. Fish tissue, chicken and pork have been prepared at RIVO's technical facilities.. The cleaned extracts, standard solutions and spiked vegetable oils have been prepared at RIVO's laboratories, including the ampouling of these materials.

The chicken type materials were provided free of charge by RIKILT and were packed by RIVO. RIVO has been in close contact with the sub-contractors NIZO Food Research (milk sample), ID-Lelystad (contaminated pork meat) and Nutreco (animal feed).

The transportation of materials for WP-3 and 5 was organised by RIVO.

Milestones and deliverables

Milestone no. 1 and 2 (see Annex 2) and deliverable no. 1 and 2, have been completed (see Annex 2).

4.2 Work package 2: Homogeneity and Stability studies

The objective of this work package is to determine the homogeneity and the stability of the 5 produced materials.

Within WP-1 the following 5 candidate CRMs have been prepared:

- Diff 01: Fish (herring) tissue
- Diff 02: Pork meat,
- Diff 03: Milk,
- Diff 04: Herring oil,
- Diff 05: Compound feed.

A homogeneity study of these materials was carried out to assess if the material would be homogeneous, which means that the matrix compounds (e.g. protein, moisture and lipids) as well as the target compounds (dioxins, dl-PCBs and indicator PCBs) have been distributed homogeneously over the individual lots at a certain sample intake. The contribution of variance in the certified value due to possible inhomogeneity should be minimised to obtain a fit for purpose CRM.

A stability study was carried out to assess the stability of the target compounds (and matrix) at various storage conditions in order to arrive at optimal storage conditions for the CRMs. The target compounds persist in biological tissues and the environment, which implies that most compounds are very stable. In the European CHRONO project, two CRMs have been produced that showed good stability of the target compounds (PCBs and dl-PCBs) over ca. two years in herring and chub (van Leeuwen, de Boer et al. 2002; van Leeuwen, de Boer et al. 2002). Therefore, it was anticipated that this study would show similar stability results.

4.2.1 Task 4. Homogeneity of 5 candidate CRMs

Design of the study and partners involved

The homogeneity study was based on the ISO and European Commission guidelines (35 2001; EC 2002). The homogeneity study has been performed according to the 15 by 5 principle meaning that the between lot homogeneity is tested by analysis of target compounds in 15 randomly selected lots from the complete produced batch. The within-lot homogeneity is tested by analysis of 5 replicate samplings from a single lot. For pork, fish tissue and fish oil a homogenate of 5 lots has been used

for the within-lot homogeneity test because the low levels in the sample material required a sample intake as large as the complete contents of one lot.

Statistical analysis of the data shows if i) the variance within a lot is similar to the variance between lots and if ii) the variance is sufficiently low to enable a use of the materials in the test certification.

The samples have been prepared by RIVO and external contractors. The homogeneity study of the materials Diff 03 and Diff 05 was performed by VITO in Belgium. The CSIC in Spain carried out the homogeneity study of the reference materials Diff 01, Diff 02 and Diff 04. The laboratories are accredited according to ISO 17025 and have shown their competence in a large number of world-wide interlaboratory studies.

Results and discussion

The results of the homogeneity tests have been reported in full detail in a report comprising the results of the homogeneity and stability results (task 6, Annex 8). Therefore, these results will not extensively be discussed here.

Briefly, the 5 candidate CRMs have been tested for their homogeneity by analysis of the dioxins and (dl-)PCBs. A summary of the results (U_{hom}) is shown in Table 5.

Table 5. Summary of homogeneity results of the candidate CRMs

Material	Code	$U_{\text{hom, dioxins}} (\%)*$	$U_{\text{hom, (dl)PCBs}} (\%)*$
Herring	DIFF 01	3.9-12.8	2.8-8.1
Pork	DIFF 02	4.7-20.5	5.1-9.6
Milk	DIFF 03	6.0-16.5	1.6-7.9
Fish oil	DIFF-04	1.8-10	1.6-7.1
Compound feed	DIFF 05	0.8-11.1	0.6-7.6

* Based on U_{hom} and not taking into account U_{hom} . Results close to the LOQ have not been included.

Generally, the uncertainty due to inhomogeneity (u_{hom}) was larger for the dioxins than for the dl-PCBs or the indicator-PCBs. This reflects the larger variance of the results obtained at the very low ($\mu\text{g/g}$) levels of dioxins in these samples and does, therefore, not point to a larger uncertainty.

Based on the data of the (dl-)PCBs, the materials produced are homogeneous and suitable for use in a (feasibility) study for certification of CRMs. Therefore, it is recommended to perform future homogeneity testing in real CRMs based on the analysis of the dl-PCBs only. This will provide the required information on the homogeneity but at lower costs.

The pork material shows somewhat elevated U_{hom} which might be caused by a slight inhomogeneity of the material. For future production of a pork material, care should be taken for an even more careful homogenisation of the material prior to canning. Concerning the milk material, a separation of phases had occurred in the tins: a paste-like fatty substance was found on the lid of the tin, resulting in an inhomogeneity of the sample. Additional experiments were carried out to determine a suitable rehomogenisation procedure applicable for the laboratories participating in the test certification. A simple procedure (including ultrasonic treatment of the sample) was found sufficient to rehomogenise the sample prior to sub-sampling. For the future production of a milk CRM it should be considered if a freeze dried sample is easier to work with at laboratories that should use the milk CRM.

4.2.2 Task 5. Stability 5 candidate CRMs

Design of the study and partners involved

The stability study of the 5 candidate CRMs has been performed by CARSO. The CARSO laboratory is accredited according to ISO 17025 and has proven its competence in earlier projects on the production of environmental CRMs for dioxins and dl-PCBs.

The stability study of the five reference materials was performed by CARSO in France according to ISO and the European Commission principles on the production of CRMs (35 2001; EC 2002). Five replicates of each material have been stored at temperatures of -20 (reference temperature), 5, 20 and 45°C. The storage times were $t= 0, 3$ (short term stability study, 45°C only), 6, 12 and 18 months. Details on storage times and temperatures can be found in Annex 8, Table IX and X. After storage time, the 5 replicates of each T,t-combination (including 5 replicates stored at -20°C) were analysed. The average results for T,t-combination (including the standard deviation of the results) is compared to the reference temperature results according to the following equation:

$$R_{(T^{\circ}\text{C}, \text{time})} = X_{(T^{\circ}\text{C}, \text{time})} / X_{(-20^{\circ}\text{C}, \text{time})}$$

X = mean value of the n measurements

T°C = storage temperature

time = time of storage

Results and discussion

Combination of the results at different storage times and temperatures leads to the below shown typical stability graph. All results and discussion can be found in full detail in Annex 8.

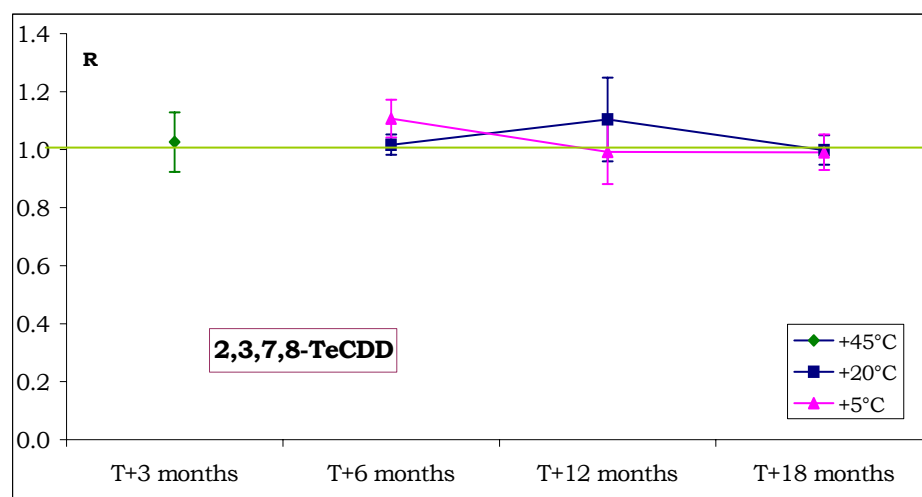

Figure 1. Stability graph of 2,3,7,8-TCDD in whole milk.

This example shows a good stability of the 2,3,7,8-TCDD over the tested period of time as R is close to 1. Also at an elevated temperature (45°C), the short term stability experiment (t=3 months) reveals good stability of the target compound in the milk sample. Generally, all materials show good stability with R values between 0.8 and 1.2 at every storage time and temperature. This shows that it is feasible to produce materials which are stable under the storage conditions applied in this study. Therefore, no problems with stability of the target compounds in the matrix are expected with storage over a longer period of time.

Some of the variation observed can be due to analytical difficulties when analysing these materials. First of all, the samples have been analysed at the moment their storage time had passed, which means that analysis have been performed at 4 moments in time (t=3, 6, 12 and 18 months). Analysing samples at different moments in time is called 'reproducibility conditions' and may generate additional variance to the results as well as a fluctuating accuracy because the analytical methods may perform slightly differently at each moment. The developed isochronic approach (Lamberty, Schimmel et al. 1998) has the advantage of analysis under repeatability conditions thereby reducing the analytical variance. Furthermore, for milk and compound feed, at the reference temperature (-20°C) at 3 and 12 months only 1 replicate was analysed resulting in an additional error source. Finally, the herring material showed a somewhat remarkable stability development at (12 and) 18 months (see Figure 2). At 20°C, 18 months, the R increases for the majority of dioxins, dl-PCBs and the indicator-PCBs to levels (considerably) larger than 1. This phenomenon was not observed in an earlier produced comparable material (herring, certified for PCBs) within the CHRONO project (van Leeuwen, de Boer et al. 2002). The fact that the majority of the compounds show the same trend indicates that the reason for this phenomenon might be an analytical error (at the extraction phase) rather than instability of these compounds in this matrix. Some compounds, however, do not follow the same trend: OCDF, 1,2,3,6,7,8-HxCDF, (2,3,7,8-TCDF), PCB 28, 101, 105 and 52, 114 and 123 (negative trend). Therefore, an analytical error cannot completely explain the problem. On the other hand, it is unlikely that the target compounds are produced at a temperature of 20°C. Therefore, this phenomenon will need further exploration in a future certification of a fish material.

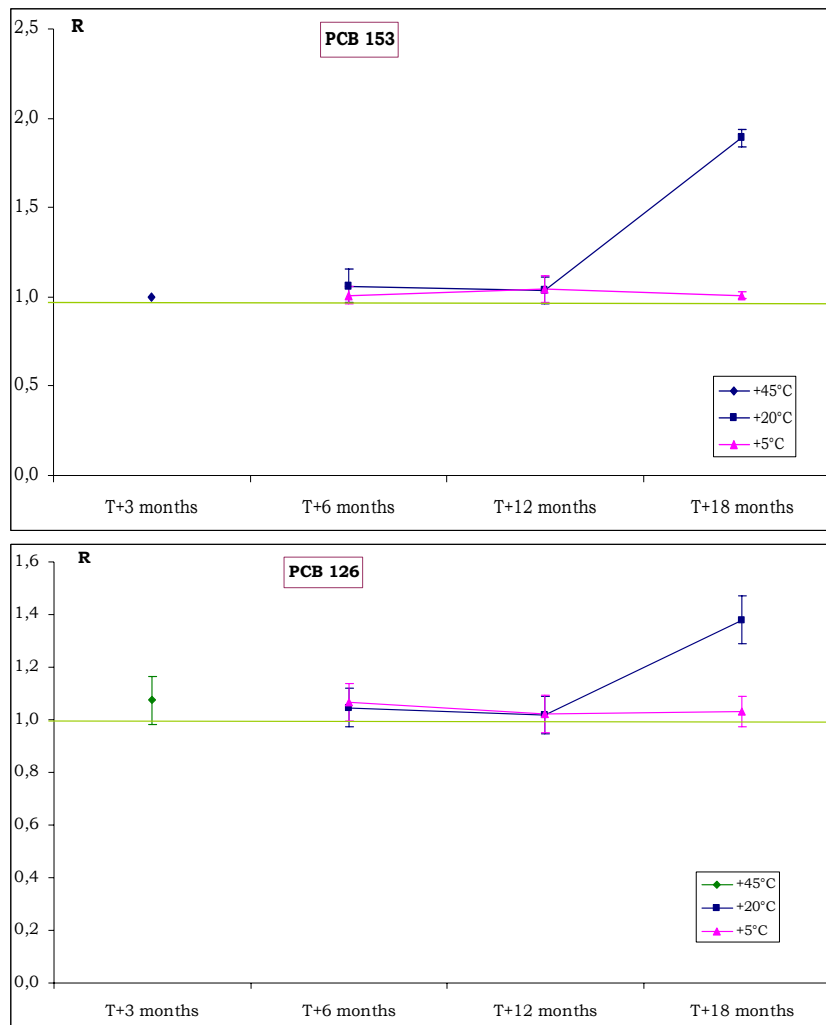

Figure 2. Stability of PCB 153 and PCB126 in herring

4.2.3 Task 6. Report homogeneity and stability study

The final report on the homogeneity studies and stability studies has been composed by CARSO, VITO, CSIC and RIVO, and can be found in Annex 8. The progress on the homogeneity and stability studies has also been reported in the various progress meetings.

4.2.4 Conclusions

The results show that the produced materials are homogeneous and are suitable for the use in the test certification (WP-4). The variance due to inhomogeneity is smaller for the PCBs than for the dioxins, which is mainly due to increased analytical variance at the very low dioxin levels. Therefore, for future certification, it is recommended to test the homogeneity solely based on the analysis of PCBs.

The liquid milk sample required a rehomogenisation step prior to subsampling, in order to dissolve the fatty solids in the liquid phase.

The results of the stability study show that the target compounds are stable in all materials at all temperature-time combinations. For the herring material at 18 months, 20°C storage, increased R-values are observed which can be due to i) an analytical error or ii) stability problems. A future certification project should pay attention to this result.

This work package showed that, in principle, homogeneous and stable materials can be produced, although some material types require special attention.

Milestones and deliverables

The following milestones (see Annex 2) have been met: M3 Homogeneity study completed and M4 Stability study completed. Deliverable D3 Report on homogeneity and stability study has been finalised.

4.3 Work package 3: Method development

The objective of this work package was the optimisation and validation of bio-analytical (CALUX and Ah-PCR) and chemical (GCxGC and GC-LRMS) screening methods and the assessment of priority validation parameters of the TEQ determinations using screening methodologies.

The optimisation of the various techniques focuses on dioxins because EU legislation on maximum levels in food and feed is now in place (EC 2001; EC 2002). However, as inclusion of dI-PCBs in legislation was expected by the end of 2004, dI-PCBs and the indicator PCBs are included in the optimisation and validation of the screening methods.

Table 6 gives an overview of the performance criteria aimed for the methods included in this project in order to fulfil the regulatory requirements. MRLs have only been set for dioxins in food and feed (EC 2001; EC 2002). The performance criteria for screening techniques are based on the Commission Directive 2002/69/EC (EC 2002).

The optimisation and method validation (subdivided in three rounds of interlaboratory tests) strongly links to the validation and standardisation work in WP-6.

Table 6. European performance criteria for screening techniques in food and feed (dir. 2002/69/EC)

Matrix	MRL	Action limit	Limit of detection**	CV	Rate false negatives
				(%)	(%)
	PCDD/Fs* (pg-TEQ/g fat)				
Fish oil***	6	4	1.2	30	<1
Compound feed	0.75	0.5	0.15	30	<1
Fish	4****	2.7	0.8	30	<1
Pork fat	1	0.66	0.2	30	<1
Milk	3	2	0.6	30	<1

* Currently, no EU legislation exists for dioxin-like PCBs. This is expected by the end of 2004.

** Defined as 1/5th of the MRL level

*** Intended for use in feed production

**** On wet weight basis

4.3.1 Task 7. CALUX optimisation

Design of the study and partners involved

CALUX has been developed in the 1990's and is routinely applied by IPH, VITO and RIKILT.

The optimisation of the CALUX method (performed by RIKILT, IPH and VITO) focussed on the following issues:

- Improvement of the method accuracy by reduction signal induction by interfering compounds (agonists) and by decreasing the effect of compounds that can reduce the signal obtained from the target compounds (antagonists).
- Calibration of the method
- Influence of DMSO solvent on the final result
- Application of recovery correction
- Sample preparation

Both the two commercially available CALUX cell lines, rat based (from BDS, Amsterdam, The Netherlands) used by RIKILT and VITO and mouse based (from XDS, USA) used by IPH, are included in the consortium and are evaluated in the optimisation and the three rounds of interlaboratory tests.

Results and discussion

Initially, CALUX users (i.e. RIKILT, VITO, IPH) exchanged information on their laboratory facilities and approaches at the kick-off meeting in IJmuiden (4-7 February 2002) and a separate CALUX meeting at VITO (Geel) took place at 15 March 2002. The discussion in these meetings focussed on:

- sample preparation (extraction solvents, vacuum drying) and
- exposition and detection (numbers of cells per well, numbers of wells per plate, induction factors, models of calibration).

Another meeting took place at IPH (Brussels) on 28 March 2003. The participants discussed about the results of the pre-round and round 1. The discussions covered the different ways of purification and the differences between the REP values. The minutes of that specific meeting are attached as Annex 9. A fourth meeting took place in Brussels (8 June 2004) to compare the working conditions of the different groups.

Preceding the three validation (interlaboratory) rounds presented in Task 12, a preliminary "testing" period was inserted in view of optimising and validating the different CALUX methods that are used in the interlaboratory tests. The two rounds of that study have been finalised; different standard solutions, feedstuff, salmon, butter were analysed by the different laboratories and the results were evaluated. These results are discussed under task 12.

The CALUX results of the PCB fraction are lower compared with GC-HRMS. This can be explained by the differences between CALUX relative potency (REP) and WHO-TEQ. The REPs for the CALUX are sometimes lower and in other cases higher than the TEF values. The results of the WP-3 round 2 were recalculated using the CALUX REPs. In Table 7 the results are compared with the theoretical values of the spikes. This clearly shows that CALUX overestimates the dioxin-fraction by a factor of ca. 1.5 compared to the theoretical spiking values, whereas the dl-PCB fraction was underestimated by a factor of 3. In this case, where the TEQ concentrations are similar for dioxins and dl-PCBs, the total of dioxins and dl-PCBs is underestimated by CALUX (ca. 15-20%). However, in samples where TEQ concentrations of dioxins and dl-PCBs are not equal, this can lead to a different under/overestimation of the TEQ compared to GC-HRMS data.

Table 7. Comparison of the spiking levels of WP-2 round 2 vegetable oils compared to the theoretical (predicted) CALUX response.

Spiking level (pg TEQ/g lw)	CALUX response/spiking level	Dioxins	dl-PCBs	Total
0.20	CALUX (pg calux TEQ/g lw)	0.26	0.06	0.32
	Spike (pg TEQ/g lw)	0.17	0.19	0.37
0.75	CALUX (pg calux TEQ/g lw)	0.99	0.23	1.23
	Spike (pg TEQ/g lw)	0.68	0.74	1.42
1.50	CALUX (pg calux TEQ/g lw)	1.97	0.46	2.44
	Spike (pg TEQ/g lw)	1.34	1.48	2.82
3.00	CALUX (pg calux TEQ/g lw)	3.86	0.91	4.77
	Spike (pg TEQ/g lw)	2.62	2.89	5.52
6.00	CALUX (pg calux TEQ/g lw)	7.71	1.82	9.53
	Spike (pg TEQ/g lw)	5.24	5.78	11.01

These results are presented in the following publication (Annex 10):

Sophie Carbonnelle, Joris Van Loco, Ilse Van Overmeire, Isabelle Windal, Nathalie Van Wouwe, Stefan Van Leeuwen, Leo Goeyens, Importance of REP values when comparing the CALUX bioassay results with chemoanalyses results. Example with spiked vegetable oils. *Talanta* 63: 1255-1259, 2004.

To correct the results in the same way for all the laboratories, it was decided to analyse a reference sample in the same time as the samples for the WP4.

Conclusions on the CALUX method

CALUX results can be higher compared to GC-HRMS due to the signal induction by matrix compounds and other contaminants with dioxin-like activity.

The signals of dl-PCBs produced by CALUX are lower than those produced by GC-HRMS. This can be explained by the differences between CALUX REPs and WHO-TEQs. To solve this problem, a control sample should be used for correction. This approach is applied by RIKILT, whereas the IPH laboratory separates the dioxins from the PCBs and only takes the dioxin fraction into account (when dioxins need to be reported).

4.3.2 Task 8. Ah-PCR development and optimisation.

The DELFIA-test which was initially included in the project proposal appeared to be not suitable for the detection of dioxins and dioxin-like PCBs. Therefore, the study of that test has been replaced by a study on the Ah-Polymerase Chain Reaction (PCR) technique of the same manufacturer (Hybrizyme Corporation, Raleigh, USA). Detection is based on DNA real-time amplification and fluorescence detection. This technique has the advantage that no cell-lines (and related lab infrastructure) are needed for detection.

The work on this new method is carried out by JRC-Institute for Reference Materials and Measurements (IRMM) in Geel. The responsible persons and laboratory moved during the course of the project (originally, the work was performed at the Joint Research Centre (JRC), Ispra, Italy), resulting in a serious delay in the method development and optimisation. Furthermore there were some initial problems obtaining Ah-PCR kits from the supplier. For these reasons, this part of method development within the DIFFERENCE project was very limited. The method has therefore not been optimised completely yet and could not be included in the interlaboratory studies (Task 12) and the WP-4 test certification.

Some of the work carried out comprised:

1. Testing regression of the calibration curve using TCDD standards in methanol and DMSO.
2. The PCR efficiency has been tested and was found 300%, whereas theoretically, it cannot be higher than 100%. The reason for this is not yet understood.
3. Blank study; the signal is amplified by interferences from the reagent blank.

The effects of 2 and 3 overestimate the concentration, which increases the risk of false positive results.

More details of the method development results can be found in the presentations of mr Maquet (JRC-IRMM, Geel, Belgium). A report will be written on the results obtained.

4.3.3 Task 9. GCxGC development and optimisation

Design of the study and partners involved

The optimisation of the GCxGC technique is carried out in collaboration with the DIAC project. The optimisation of the technique has focused on (1) the choice of the best modulator system and (2) the best column combination for the first and second dimension. The method development and optimisation took place in year 1 and 2 of the project. During these experiments, ECD was used as the detection technique.

RIVO has purchased a time of flight-MS (ToF-MS, Tempus from Thermo Finnigan, Hemel Hempstead, Herts, UK) for detection (after GCxGC separation) of the target compounds in the DIFFERENCE and DIAC projects. The goal of the experiments was to evaluate the potential of this recently introduced, less expensive MS technique. ToF-MS had been shown to be very suitable in GCxGC due to its high acquisition rate and documented low-pg level detection. This instrument is the first instrument worldwide that is equipped with an electron capture negative ionisation (ECNI) source. However, after initial tests, the ECNI source did not work properly. Therefore, the instrument has been repaired several times and finally, after substantial delays, it was decided that RIVO would receive a new and a more sensitive ECNI source. This machine was installed in autumn 2004 at RIVO's laboratory. These problems have caused that GCxGC could not be fully validated until now. Nevertheless, some experiments with GC-ToF-MS have been performed. Temporarily, the instrument was run in the one-dimensional GC mode (GC-ToF-MS) as the modulator was not incorporated in the system yet. As an alternative to the temporarily unavailable GC-ToF-MS, experiments have been performed to explore the potential of fast scanning quadrupole MS (qMS) as a detection technique for GCxGC. Recently, fast-scanning quadrupole MS (qMS) low cost instruments (Clarus 500 from Perkin Elmer, Shelton, CT, USA) were introduced on the market. The electronic development of quadrupole instruments has been improved substantially, and the scan speed of these instruments has increased dramatically. Because of the lower investment compared to, for instance a high resolution or a ToF-MS instrument, its possibilities as a detector for GCxGC were evaluated in this project. The instrument had an electron-capture negative ion (ECNI) option which is highly desirable for the analysis of halogenated compounds.

In order to decide if GC-ToF-MS or GCxGC-qMS are alternatives for the standard GC-HRMS system, various analytical parameters were evaluated in collaboration with the DIAC project. The GC-ToF-MS was run in the electron impact (EI) mode, whereas the Perkin Elmer qMS which was run in both EI and ECNI mode. Linearity and signal stability, and the limit of detection were studied. Due to the fact

that the limit of detection is influenced by the modulation frequency, this parameter was determined for typical settings of 4-5 heart cuts per first dimension peak.

Results and discussion

The modulators that have been evaluated included the moving thermal desorption (Sweeper) system and cryogenic systems like the loop-CO₂/N₂ modulator (ZOEX, Linclon, Nebraska, USA). The limits of detection (LOD) for the cryogenic system, using μ -ECD, is approximately 40-200 fg absolute (2 μ l injection) for TCDD and dioxin-like PCBs.

Several column combinations have been studied by RIVO and Umeå University. It can be concluded that the combination DBXLB-LC50 is the best one regarding PCB and PCDD/F separation and separation from matrix components. Table 8 presents an overview of the column combinations and the quality of the separation of dioxins and dl-PCBs.

Table 8. Overview of the column combinations and their performance in the separation of dioxins and dl-PCBs.

1 st column	2 nd column	Partner	Comment
DBXLB	LC50	Umeå	Good separation
	VF23		Hard to separate target compounds from matrix components.
DB1	LC50		Good separation, but some coelutions.
HT5	LC50		More modulated bleed in 1 st dimension.
DBXLB	HT8		Poor separation.
LC50	DB1		Very high bleed in 1 st dimension.
DB1	007-65HT	RIVO	Coelution with matrix components
	VF-23		Coelution with matrix components
	LC-50		Wrap around (too long retention times for dioxins in 2 nd dimension)
	Supelcowax-10		Decomposition of OCDF and a heptaCDF
	HT-8		Poor separation of standard mixture
	007-210		Poor separation of standard mixture
	BPX-50		Poor separation of standard mixture
	OV-1701		Poor separation of standard mixture
HT-5	007-65HT		Good separation of a standard mixture
DB-Dioxin	-		Too much bleeding for use in GCxGC

The LC-50 column gives a good separation of a standard and also from matrix interferences. In some cases, the retention times become too long in the second dimension resulting in wrap around. This may be improved after further optimisation. It is expected that a narrow bore LC-50 column can further improve the separation. However, currently such a column is not commercially available and could therefore not be tested in this project.

The results of the optimisations and the conclusions on the performance of the various modulators and on the GCxGC technique in general are presented in various publications Annex 11 to Annex 14.

The work of RIVO and Lund University has also been presented at the Dioxin 2003 congress in Boston, USA and both presenters (C. Danielsson and P. Korytar) were selected for the group of best six student presentations and nominated for a student award. C. Danielsson has won the award (Figure 3).



Figure 3. Conny Danielsson showing the student award he has won for his lecture at Dioxin 2003 in Boston, USA, 2003.

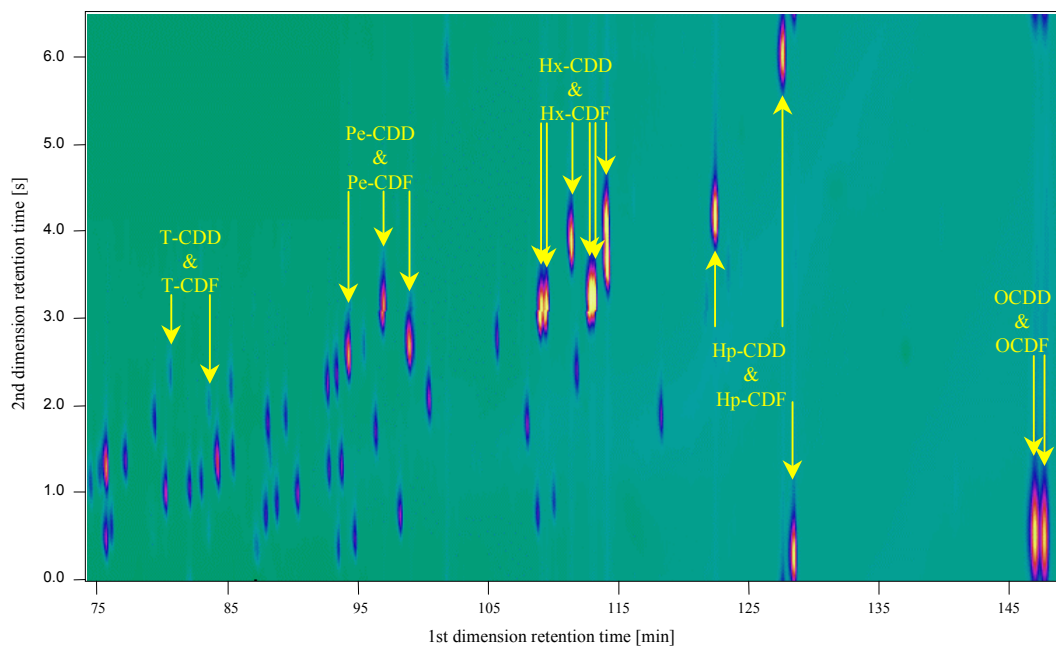

Figure 4. Separation of a mixture of 90 PCBs (partly visible) and 17 WHO dioxins and furans by GCxGC/ECD on a HP-1 – HT-8 column combination. Details can be found in (Korytar, Leonards et

Although the progress in the development of the GCxGC technique has been substantial until now, problems have been identified as well. The most serious, but hopefully temporal problem is that of the time needed for interpretation and integration of chromatograms. Software is currently being developed at several places in the world and test versions have already been used in the DIFFERENCE and DIAC groups. It is expected that the first robust, ready-to-use versions will become available in the next few years.

Secondly, the sensitivity of the micro-ECD may not be sufficient for a proper detection of dioxins in some samples with concentrations below the EU MRLs (at the so-called action limits).

GCxGC-Single quadrupole MS and Time-of-Flight MS

The LODs obtained for PCDD/Fs and PCBs are summarized in Table 9. The LODs obtained by the Thermo Finnigan ToF-MS in EI mode were of 2-6 pg. These LODs are 100-1,000 fold higher than the desired values at the low fg level. It is expected that the LODs for the Thermo Finnigan instrument

will be improved when the GCxGC modulator is installed due to the peak-focusing effect. It should be added that the detector technology of multi-channel plates is improving year after year, which also will help to improve the LODs in the near future. A recent publication by Focant et al. (Focant, Reiner et al. 2004) confirms the above statement. The cited group reported an LOD in the 0.1-0.5 pg range for the latest state-of-the-art GCxGC-ToF-MS Leco instrument. These LODs are in the range according to the EU Directives 2002/69 and 2002/70. Another option to improve the LOD is the use of chemical ionisation (ECNI). Indeed, using GC-ToF-MS the LODs for the PeCDD/Fs, HxCDD/F, HpCDD/Fs, OCDD/F the LOD were improved (Table 9). The LODs for these compounds range between 300 and 500 fg. However, for TCDD and TCDF no improvement between EI and ECNI mode was observed. Using the GCxGC modulator and ToF-MS in the ECNI mode further improved the LOD. The LODs were similar to the LODs of the qMS technique. The application of GCxGC-ToF-MS in ECNI mode is shown in Figure 5, in which a feed extract of round 3 is shown. The TIC-chromatogram shows many peaks, but the selected ion-chromatograms show clearly the HxCDF and HpCDFs. TCDD and TCDF could also be identified in this sample.

Table 9: Limits of detection (fg) of PCDD/Fs and PCBs for GCxGC-ToF-MS and GCxGC- qMS for EI or ECNI mode. Results of GCxGC-ToF-MS in EI mode (Leco) were taken from the DIAC project.

Component	GCxGC-ToF-MS in EI mode (Leco)	GC-ToF-MS in EI mode (Thermo)	GC-ToF-MS in ECNI mode (Thermo)	GCxGC-qMS in ECNI mode (PE)	GCxGC-ToF-MS in ECNI mode (Thermo)
Non-ortho CBs	11000-15000	3000-4000	n/a	n/a	n/a
Mono-ortho CBs	8000-10000	2000	n/a	n/a	n/a
TCDD	10000	3000	3000	710	800
PeCDD	30000	4000	500	40	100
HxCDDs	25000	4000	300	20-50	50
HpCDDs	23000	3000	300	70	50
OCDD	40000	6000	1000	430	500
TCDF	10000	3000	1000	100	
PeCDFs	22000-30000	2000-3000	500	10-30	100
HxCDFs	18000-22000	3000	300	10-100	20
HpCDFs	22000-30000	3000-6000	300	10-50	20
OCDF	40000	4000	500	110	100

n/a: not analysed.

In conclusion, unless better detectors become available for ToF-MS or chemical ionisation can be used, GCxGC-ToF-MS can only be used for detection/confirmation/identification at relatively high PCDD/F and non-ortho CB levels such as found in environmental samples, e.g. sewage sludge, sediment and fatty biota.

An important parameter for a detector of GCxGC is the scan speed which should be high enough for quantitative analysis. The Perkin Elmer instrument is able to obtain a scan speed up to 90 Hz for a single ion. In the scan mode good-quality mass spectra covering a range 300 Da were obtained at an acquisition rate of 23 Hz. There was no extra peak broadening by the use of ECNI compared to EI mode.

The LOD was evaluated under two sets of parameters. It was attempted to have an as broad as possible view, that is using the widest possible mass range, while still acquiring fast enough to catch the fast peaks. The Perkin-Elmer system that had the ECNI option showed LODs that were required for most priority PCDD/Fs (Table 9). Here, however, there were two exceptions, OCDD and 2,3,7,8-TCDD, for which the ECNI mechanism does not provide enough sensitivity (LODs of 450 and 710 fg, respectively). This means that further work is needed before the present technique can be recommended as a replacement for GC-HRMS in dioxin analysis.

Conclusions on the GCxGC development and optimisation

Both ToF-MS systems in EI mode show too high LODs for the analysis of PCDD/Fs in food and feed samples. The ECNI option of one of the ToF-MS systems may be able to reach the required limits but more research is necessary to improve the sensitivity for OCDD and 2,3,7,8-TCDD. The present qMS

systems are suitable as detector for GCxGC. However, only the system with the ECNI option acquired LODs close to the required levels. qMS systems without ECNI can be used to analyse more contaminated samples, such as sewage sludge or sediment. Further improvement is needed to make this technique suitable for food analysis.

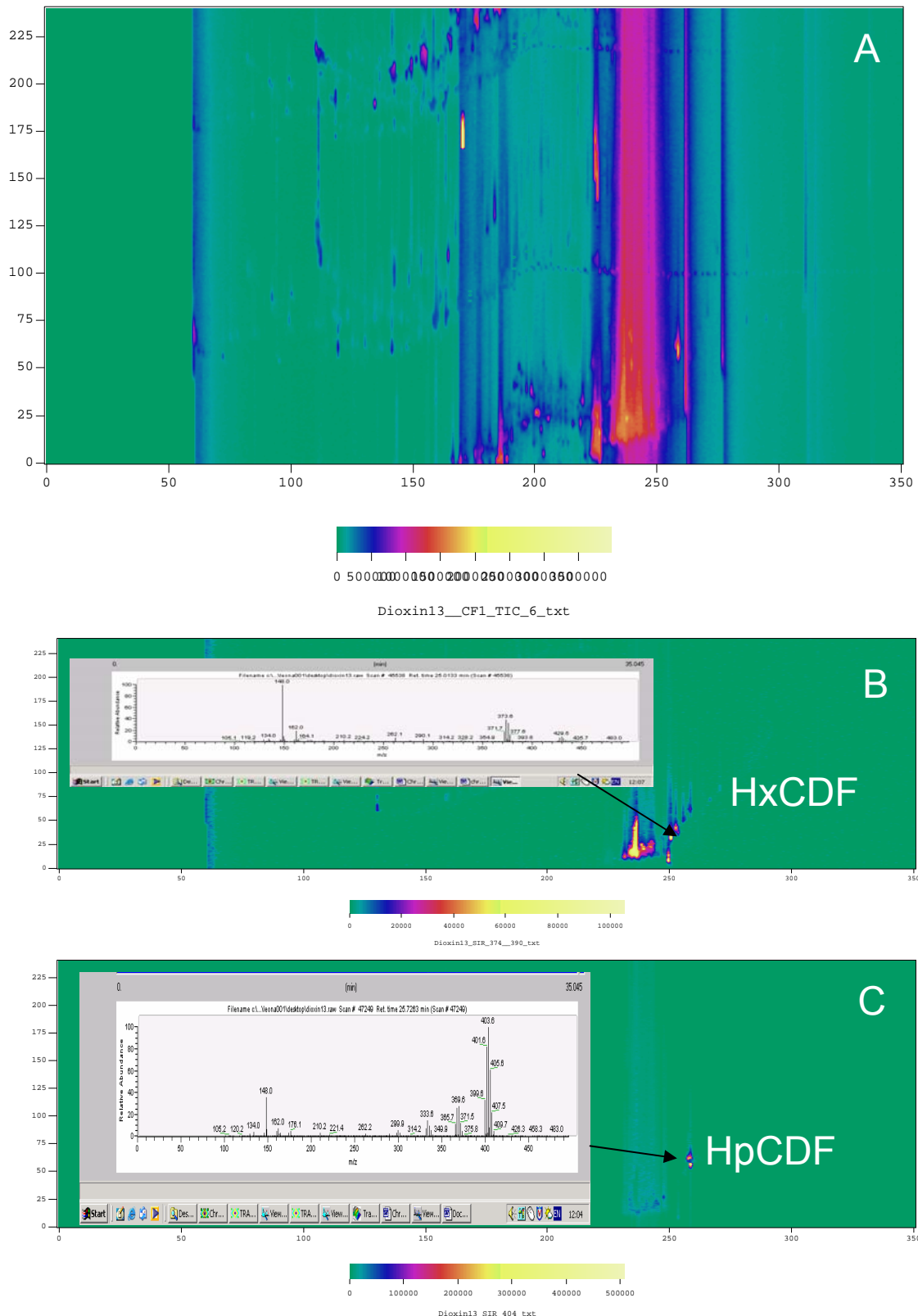

Figure 5. GCxGC-ToF-MS chromatogram of a compound feed extract of WP-3 round 3. A: TIC-chromatogram, B: selected ion chromatogram (m/z 374), marked are the HxCDFs and in the insert

the mass spectrum of one of the HxCDFs, C: selected ion chromatogram (m/z 408), marked are the HpCDFs and in the insert the mass spectrum of one of the HpCDFs.

4.3.4 Task 10. LRMS/MS optimisation

Design of the experiments and partners involved

At the laboratory of sub-contractor University of Barcelona, the development and optimisation of the GC-LRMS/MS method was accomplished during the first 4 months of the project. The research on the ion-trap MS/MS comprised the optimisation of the following MS/MS parameters:

- selection of precursors ions
- m/z width of the precursor ion isolation window
- isolation time
- fragmentation of precursor ions and storage of the product ions
- resonant excitation RF voltage
- maximum excitation energy (q value)
- selection of the characteristic product ions

The laboratory of sub-contractor University of Barcelona collaborated closely with CSIC in Barcelona. The latter performed the extraction and clean-up of all samples (WP-3, WP-4) that have been analysed by GC-LRMS/MS.

Furthermore, at RIKILT, experiments have taken place in order to evaluate large volume injection (LVI) in combination with single quadrupole MS. Initial experiments showed that the separation power of the quadrupole MS was insufficient for a selective quantification of the target compounds due to interferences. No further research has been carried out on the GC-LVI-MS method.

Results and discussion

The development and optimisation of the GC-LRMS/MS method was accomplished during the first 4 months of the project. The instrument used to perform all experiments was the GCQ/Polaris GC-MS from ThermoFinnigan with an ion-trap analyser.

The following instrumental tandem MS parameters, of which some affect the isolation of precursor ion and others affect its excitation and fragmentation, have been optimised according to the DoW:

- *Isolation of the Precursor ions*: the most abundance ion of the molecular cluster ions for each homologue group was selected as precursor ion. The following parameters were sequentially optimised:
 - *Isolation window width*: Different isolation windows ranged from ± 4 m/z to ± 0.5 m/z around of each precursor ion were studied. The best selectivity and relatively high sensitivity was achieved using ± 1 m/z as a compromise.
 - *Isolation time*: This parameter was studied between 2 and 12 ms, allowing the optimal conditions at 10 ms.
- *Fragmentation of precursor ions and storage of the product ions*: the following parameters which affect the fragmentation of the precursor ions and the stabilization of the product ions were optimised:
 - *Resonant excitation RF voltage*: The fragmentation of the different precursor ions corresponding to each homologue group was optimised in order to obtain the maximum abundance of the product ions. For this purpose, RF voltages ranged from 0.1 to 2 V were studied. The optimum values obtained for PCDD/Fs are mentioned in

Table 10 and dioxin-like PCBs (Table 11). The two product ions from each precursor ion corresponding to the loss of two chlorine atoms for dioxin-like PCBs and COCl fragment for PCDD/Fs were selected for quantification.

- *Excitation time*: The time required to obtain maximum fragmentation was also optimised between 5 and 20 ms, allowing the optimum value for all target compounds at 15 ms.
- *Maximum excitation energy (q value)*: Finally, the best conditions for fragmentation was obtained with q value of 0.45 which corresponding to high energy.

Table 10. Precursor ions, excitation RF voltage and product ions selected for MS/MS analysis of PCDD/Fs.

Target compounds	Precursor ion		Excitation RF Voltage (V)	Product ion	
	Ion	m/z		m/z	M/z
T4CDDs	M+2	321.9	1.3	256.9	258.9
¹³ C ₁₂ -T4CDDs	M+2	333.9	1.3	267.9	269.9
P5CDDs	M+2	355.9	1.3	290.9	292.9
¹³ C ₁₂ -P5CDDs	M+2	367.9	1.3	301.9	303.9
H6CDDs	M+2	389.8	1.6	324.8	326.8
¹³ C ₁₂ -H6CDDs	M+2	401.9	1.6	335.9	337.9
H7CDDs	M+2	423.8	1.7	358.8	360.8
¹³ C ₁₂ -H7CDDs	M+2	435.8	1.7	369.8	371.8
O8CDDs	M+4	459.7	1.7	394.7	396.7
¹³ C ₁₂ -OCDs	M+4	471.8	1.7	405.8	407.8
³⁷ Cl-2,3,7,8-T4CDD ⁽¹⁾	M	327.9	1.3	262.9	-
T4CDFs	M+2	305.9	1.4	240.9	242.9
¹³ C ₁₂ -T4CDFs	M+2	317.9	1.4	251.9	253.9
P5CDFs	M+2	339.9	1.5	274.9	276.9
¹³ C ₁₂ -P5CDFs	M+2	351.9	1.5	285.9	287.9
H6CDFs	M+2	373.8	1.6	308.8	310.8
¹³ C ₁₂ -H6CDFs	M+2	385.9	1.6	319.9	321.9
H7CDFs	M+2	407.8	1.7	342.8	344.8
¹³ C ₁₂ -H7CDFs	M+2	419.8	1.7	353.8	355.8
O8CDFs	M+4	443.7	1.9	378.7	380.7

⁽¹⁾ It is used to measure the efficiency of the clean-up process (US EPA method 1613)

Table 11. Precursor ions, excitation RF voltage and product ions selected for MS/MS analysis of dioxin-like PCBs.

Target compounds	Precursor ion		Excitation RF Voltage (V)	Product ion	
	Ion	m/z		m/z	m/z
CB-77,81	M+2	291.9	1.4	219.9	221.9
¹³ C ₁₂ -CB-77,81, (70)	M+2	304.0	1.4	232.9	255.9
CB-126,123,118,114,105	M+2	325.9	1.4	253.9	255.9
¹³ C ₁₂ -CB-126,123,118,114,105, (111)	M+2	337.9	1.4	265.9	267.9
CB-169,167,156,157	M+2	359.8	1.4	287.8	289.8
¹³ C ₁₂ -CB-169,167,156,157, (138)	M+2	371.9	1.4	299.9	301.9
CB-189	M+2	393.8	1.4	321.8	323.8
¹³ C ₁₂ -CB-189, (170)	M+2	405.8	1.5	333.8	335.8

Other MS parameters such as source temperature (210°C), multiplier gain (10⁵, with 1750V) and maximum ionisation time (25 ms) or damping gas, were previously optimised to the MS/MS parameters. The chromatographic separation of the target compounds was carried out on a DB-5ms (Agilent) fused silica column (60 m x 0.25 mm I.D., 0.25 µm film thickness). The optimisations were initially performed using standard solutions of PCDD/Fs, non-ortho-PCBs and mono-ortho-PCBs. After optimisation, the developed methods were evaluated using reference materials such as CARP-1

(NRC, Canada) and BCR-719 (EU), and analysing food and feed samples such as eel, milk, fish oil, which were also used for other optimisation I DIFFERENCE. The same samples were also analysed by GC-HRMS. The results obtained with both methods, LRMS/MS and HRMS, agreed with the certified values (see Table 12).

In order to determine the suitability of GC-LRMS/MS for the analysis of PCDD/Fs and dI-PCBs in food samples, the subcontractor participated (WP3) in three interlaboratory rounds following the validation protocol of task 12. These results will be discussed under Task 12. Below some results of round 1 are shown, including 1) six standard solutions, containing TCDD at a different levels, and a blank (injected in duplicate); 2) a vegetable oil spiked with PCDD/Fs and dioxin-like PCBs (single analysis); 3) a clean fish extract (analysed in duplicate); 4) milk and fish oil samples (analysed six fold in three different runs). The standards and the samples were also analysed by GC-HRMS, in order to be able to compare the results of the developed screening methods to those obtained with the reference method. The results obtained with the two methods are summarised in Table 13.

Table 12. Analysis of PCDD/Fs in the fish CARP-1 (NRC reference material)

Compound	Concentration (pg · g ⁻¹)		Certification value Mean ± s.d.
	GC-LRMS/MS	GC-HRMS	
2,3,7,8-TCDF	12.7	11.3	11.9 ± 2.7
1,2,3,7,8-PCDF	6.9	9.04	5.0 ± 2.0
2,3,7,8-TCDD	7.1	7.02	6.6 ± 0.6
1,2,3,7,8-PCDD	5.1	4.47	4.4 ± 1.1
1,2,3,4,7,8-HxCDD	1.2	1.60	1.9 ± 0.7
1,2,3,6,7,8-HxCDD	5.9	5.38	5.6 ± 1.3
1,2,3,7,8,9-HxCDD	0.9	0.71	0.7 ± 0.4
1,2,3,4,6,7,8-HpCDD	8.2	8.49	6.5 ± 1.8
OCDD	8.0	12.35	6.3 ± 1.9

Table 13. Upperbound results of first round validation (task 12)

Sample	GC-LRMS/MS		GC-HRMS	
	Repetition 1	Repetition 2	Repetition 1	Repetition 2
(ng / mL)				
Standard A	0.139	0.125	0.155	0.128
Standard B	0.421	0.475	0.464	0.477
Standard C	4.48	4.02	4.27	3.94
Standard D	49.1	45.6	46.4	45.98
Standard E	87.2	91.5	85.83	88.03
Standard F	178	188.2	181.29	189.86
(pg total WHO-TEQ / g)				
QCS (Vegetable oil)	2.94+2.88*		2.536+2.965	
Clean fish extract	7.65+20.73	7.86+20.64	6.845+21.862	7.379+21.789
(pg total WHO-TEQ / g fat)				
Milk	Run 1	3.9+7.44	3.63+6.95	3.268+7.019
	Run 2	4.28+7.04	4.09+6.47	3.649+5.659
	Run 3	3.7+7.28	3.92+6.28	3.004+6.326
Fish Oil	Run 1	4.05+4.01	4.13+5.01	3.878+3.537
	Run 2	4.39+4.8	4.6+4.96	5.046+4.093
	Run 3	3.93+4.95	4.51+5.12	5.23+3.862

* First value is related to PCDD/F content and second value is related to PCB content

Table 14. Lowerbound results of first round validation (WP 6)

Sample	GC-LRMS/MS		GC-HRMS		
	Repetition 1	Repetition 2	Repetition 1	Repetition 2	
(ng / mL)					
Standard A	0.139	0.125	0.155	0.128	
Standard B	0.421	0.475	0.464	0.477	
Standard C	4.48	4.02	4.27	3.94	
Standard D	49.1	45.6	46.4	45.98	
Standard E	87.2	91.5	85.83	88.03	
Standard F	178	188.2	181.29	189.86	
(pg total WHO-TEQ / g)					
QCS (Vegetable oil)	2.7+2.88*		2.53+2.965		
Clean fish extract	7.32+20.73	7.56+20.64	6.806+21.862	7.271+21.789	
(pg total WHO-TEQ / g fat)					
Milk	Run 1	3.65+7.44	3.37+6.95	3.268+7.019	3.399+7.420
	Run 2	4.03+7.04	3.84+6.47	3.649+5.659	4.042+5.845
	Run 3	3.45+7.28	3.66+6.28	3.004+6.326	3.202+4.847
Fish Oil	Run 1	3.61+4.01	3.69+5.01	3.810+3.537	4.416+4.946
	Run 2	4.13+4.8	4.34+4.96	4.920+4.093	4.784+4.259
	Run 3	3.68+4.95	4.26+5.12	5.195+3.862	4.831+4.345

* First value is related to PCDD/F content and second value is related to PCB content

The results obtained in the first interlaboratory round was presented at the Dioxin 2003 congress which took place in Boston, USA (Annex 15).

Conclusions on the GC-LRMS/MS optimisation

Based on these results, the following conclusions for the method performance of GC-LRMS/MS can be drawn :

- GC-LRMS/MS using an ion-trap mass analyser is an attractive method for the determination of PCDD/Fs and dioxin-like PCBs at relatively low cost compared with GC-HRMS.
- Low detection limits (0.6-0.9 pg g⁻¹), good repeatability (RSD%, 5-12%) and high selectivity were obtained with MS/MS, avoiding the potential interferences of other related compounds such as PCBs, PCDEs and PCNs.
- For vegetable oil, a limit of detection of 0.26 pg of WHO-TEQ/g was obtained which is 3-folds lower than the EU-MRL.
- An important reduction of the sensitivity of the GC-LRMS/MS technique is found for insufficiently cleaned extracts. In order to minimise this detection problem, an exhaustive quality control programme of the instrument is recommended.

4.3.5 Task 11. HRMS optimisation

At the kick-off meeting it was decided to put minimal efforts into the GC-HRMS detection technique because this technique, the reference technique throughout the project, was already thoroughly tested and validated. It was believed that the sensitivity could not be further improved. Sensitivity improvements should rather be obtained from improved extraction and clean-up, which will be discussed under work package 5.

4.3.6 Task 12. Interlaboratory tests

The objective of this task was to test the performance of the optimised screening techniques for the purpose of the analysis of dioxins and dioxin-like PCBs.

Design of the study and partners involved

A validation scheme has been included in the DoW. The scheme has slightly been adopted from 4 to 3 rounds at the kick-off meeting resulting in an improved scheme that allows more time per round without sacrificing quality of the validation study. A validation protocol has been prepared by IPH (see Annex 5), which was used as a guideline in the validation study. The validation scheme is shown in Table 15. The partners that have been involved in the validation study are mentioned in Table 16.

Table 15. Validation protocol of bioanalytical and chemical analytical screening methods

ROUND 1	ROUND 2	ROUND 3
Standard A (1x2-fold)	Blank vegetable oil (4x1-fold)	Quality control sample
Standard B (1x2-fold)	Vegetable oil + spike 0.2 pg dioxin TEQ/g and 0.2 pg PCB TEQ/g (4x1-fold)	3pg dioxin + 3pg PCB TEQ/g
Standard C (1x2-fold)	Vegetable oil + spike 0.75 pg dioxin TEQ/g and 0.75 pg PCB TEQ/g (4x1-fold)	Cereal based feed (2-fold)
Standard D (1x2-fold)	Vegetable oil + spike 1.5 pg dioxin TEQ/g and 1.5 pg PCB TEQ/g (4x1-fold)	Chicken (2-fold)
Quality control sample 3pg dioxin + 3pg PCB TEQ/g	Vegetable oil + spike 3 pg dioxin TEQ/g and 3 pg PCB TEQ/g (4x1-fold)	Vegetable feed (2-fold)
Clean fish extract (2-fold)	Vegetable oil + spike 6 pg dioxin TEQ/g and 6 pg PCB TEQ/g (4x1-fold)	Egg (2-fold)
Fish oil (3x2-fold)	Vegetable oil + 3pg dioxin TEQ/g + 3 pg PCB TEQ/g + PCB-spike (4x1-fold)	Fish tissue (3x2-fold)
Milk (3x2-fold)	Vegetable oil + 3pg dioxin TEQ/g + 3 pg PCB TEQ/g + PCN spike (4x1-fold)	Pork (3x2-fold)
	Vegetable oil + 3pg dioxin TEQ/g + 3 pg PCB TEQ/g + PCDE spike (4x1-fold)	

Table 16. Participating laboratories in the validation interlaboratory studies.

Technique	Participating laboratory
CALUX	IPH, RIKILT, VITO
GC-LRMS/MS	University of Barcelona (sub-contractor)
GCxGC-ECD	RIVO, University of Umeå
ASE & CALUX	University of Lund (ASE) & RIKILT (CALUX)
ASE & HRMS	University of Lund (ASE) & University of Umea (GC-HRMS)
GC-HRMS (reference technique)	RIKILT, University of Umeå, VITO

Results and discussion

The results have extensively been discussed in the reports that have been produced on rounds 1 and 2 (Annex 6) and on round 3 (Annex 16). Therefore, the results will not further be discussed in this section. As an example, the results of chicken compound feed are given below.

The chicken compound feed samples were analysed in duplicate in 3 different analytical runs with different equipment and operators whenever feasible. The results are summarized in

Table 17. The CV_w is below the required 30% for all the labs.

The not for recovery corrected CALUX results underestimate the total TEQ concentration of the feed sample. The results of the CALUX labs (labs A, D, E and H) are more than 50% lower than the median of the GC-HRMS results. Consequently, the SSZ-scores of the CALUX labs are unsatisfactory (Figure 6). Applying recovery correction improves the total TEQ results of these labs (A* and E*), since the SSZ-scores for CALUX* are satisfactory. The results of the GC-LRMS/MS and GCxGC-ECD are all satisfactory. The results of the ASE + GC-HRMS (see WP 5) show a significant larger variation than the GC-HRMS results. Their SSZ-scores are still satisfactory.

Table 17. Chicken compound feed validation data.

Lab	Method	n	Mean concentration (ng total TEQ/kg)	Bias	CV _r	CV _w	CV _R
A	CALUX	6	0.730	-55.6%	12.0%	13.0%	50.3%
D	CALUX	6	0.262	-84.1%	9.6%	9.6%	
E	CALUX	6	0.740	-55.0%	17.4%	22.9%	
A*	CALUX*	6	1.043	-36.6%	12.0%	12.8%	42.9%
E*	CALUX*	6	1.895	15.2%	13.7%	13.7%	
C	GC-HRMS	6	1.642	-0.2%	1.1%	1.1%	14.5%
F	GC-HRMS	6	1.716	4.3%	3.4%	3.6%	
J	GC-HRMS	6	1.302	-20.9%	1.0%	4.2%	
I	GCxGC-ECD	6	1.863	13.3%	2.9	4.6	54.6%
K	GCxGC-ECD	1	1.415	-14.0%	-	-	
G	GC-LRMS/MS	6	1.741	5.8%	4.9%	5.3%	-
H	ASE+CALUX	6	0.475	-70.7%	6.9%	23.4%	-
B	ASE+GC-HRMS	6	1.733	5.4%	2.8%	19.3%	-

The chemical screening methods (GC-LRMS/MS and GCxGC-ECD) and the GC-HRMS reference method report the total TEQ concentration in the sample as a combination of the TEQ value of the 17 dioxin congeners and of the 12 dl-PCB congeners. The TEQ results of the dioxin and dl-PCB congeners are summarized in Table 18. The results of the dioxin fraction do not deviate more than 12% from the consensus value, which is the median of the GC-HRMS results. However, the results of the dl-PCB fraction are more dispersed, even for the GC-HRMS data. The data reported by GC-HRMS lab J differ substantially from the data reported by the other GC-HRMS labs. This underestimation is systematic and is observed in all the samples analyzed in round 3.

Table 18. Results of the dioxin and dl-PCB fraction for the chicken feed sample.

Lab	Method	n	Dioxin		PCB	
			Mean concentration (ng TEQ/kg)	Bias	Mean concentration (ng TEQ/kg)	Bias
F	GC-HRMS	6	0.84	3%	0.87	5%
C	GC-HRMS	6	0.81	-1%	0.84	1%
J	GC-HRMS	6	0.80	-2%	0.50	-40%
I	GCxGC-ECD	6	0.92	12%	0.95	14%
K	GCxGC-ECD	1	0.83	2%	0.58	-30%
G	GC-LRMS/MS	6	0.90	10%	0.84	2%
B	ASE+GC-HRMS	6	0.86	5%	0.73	-12%

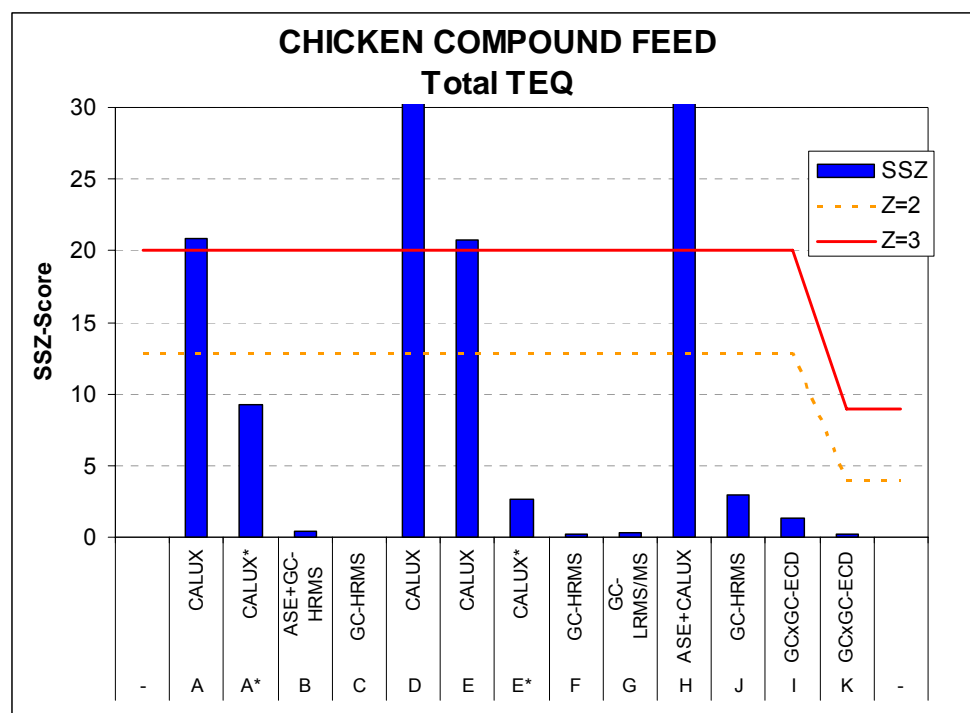

Figure 6. The SSZ-scores (total TEQ) of the repeated analysis of the Chicken Compound Feed sample.

The SSZ-score for the dioxin and dl-PCB results are given in Figure 6. The results are all categorized as satisfactory. It is noted that the SSZ-score for the dl-PCB results of lab J is considerable larger than for the other labs.

4.3.7 Task 13. Report on performance of developed methods

Two reports have been prepared comprising the results of rounds 1 and 2 (Annex 6) and on round 3 (Annex 16). Therefore, the reports will not further be discussed in this section. A publication has been produced on round 1 and 2 that has been published in a special volume of Talanta on the analysis of dioxins and dl-PCBs (Annex 7). Furthermore, the results of the validation have been presented at the Dioxin 2003 conference (Boston, USA) (Annex 17) and the Dioxin 2004 conference (Berlin, Germany) (Annex 18).

4.3.8 Cost evaluation of techniques

The aim of the project is to develop alternative techniques for the detection of dioxins and (dl-)PCBs. In order to become complementary to the reference technique GC-HRMS, the developed techniques should enable i) low-cost, ii) rapid and iii) simple determination of the target compounds.

The costs per technique have been evaluated to determine if the analysis is cheaper compared to the reference technique. The following techniques have been included in the evaluation:

- Existing techniques
 - Soxhlet / ASE extraction
 - Multilayer clean-up
 - Carbon fractionation
 - Fluid Management System combined clean-up and fractionation
 - GC-HRMS detection
- DIFFERENCE developed techniques
 - Selective ASE combined extraction, clean-up and fractionation
 - GC-LRMS/MS
 - GCxGC-ECD
 - CALUX

The costs per technique are calculated on the basis of labour (in manhours) in each step of analysis, consumable use and costs, the costs involved with instrument investment and depreciation and instrument maintenance costs (service costs). Labour costs were calculated based on an hourly rate of €75/hr for a technician only, thereby omitting effects of geographical differences in wages.

Differences in wages can influence results as wages generally are lower in Southern Europe compared to Northern Europe. Some costs have not been included because of lack of data or due to the complexity of the calculations. Excluded are:

- Downtime of instruments
- General laboratory equipment (e.g. centrifuge or turbopap)
- General laboratory consumables (e.g. gasses)
- Scientist labour (only technician)
- Costs of Quality Assurance
- Cost of calibrants

However, some information is available on these items and will be discussed below.

Various laboratories have submitted their costs and labour data, which was initially based on a limited number of sample analysis per month. The data presented below is recalculated to arrive at an estimation for the analysis of 100 samples per month under routine conditions. In total, the data of five GC-HRMS laboratories were obtained, whereas the cost estimation for the other techniques is based on a lower number of laboratories. For GC-HRMS the *range* of costs among laboratories can be determined whereas this is less feasible for e.g. GCxGC-ECD for which only the data of one laboratory was obtained.

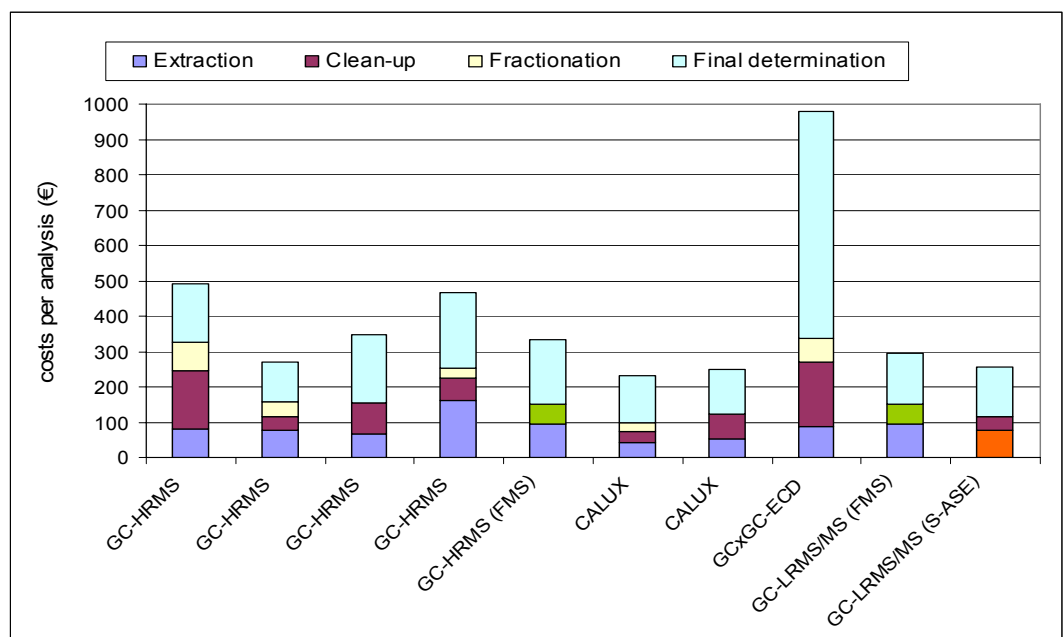

Figure 7. Costs per analysis (dioxins and dl-PCBs) for different techniques, subdivided costs per stage of analysis. The green bars represent the use the Fluid Management System combined clean-up and fractionation. The orange bar represents the use of selective ASE (including within-cell carbon fractionation).

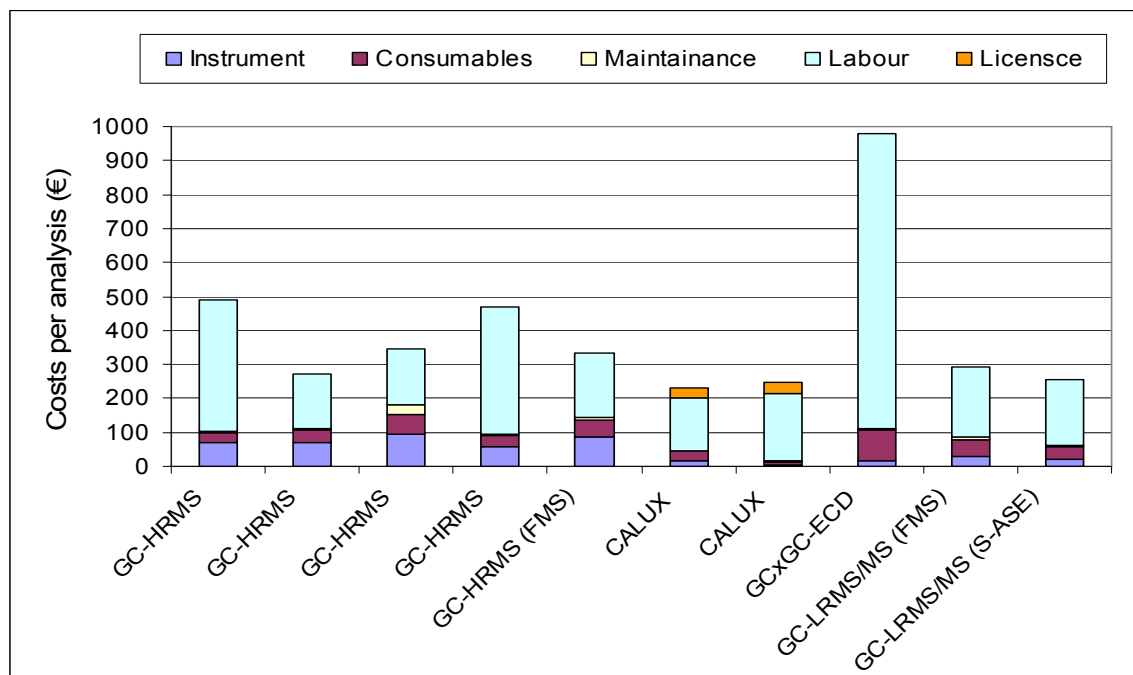

Figure 8. Costs per analysis for different techniques, subdivided in cost items. The orange bar represents the license costs for the application of CALUX.

Figure 7 and Figure 8 show the analysis costs. The costs for GC-HRMS analysis are between ca €275 to €500 per sample. This is much lower compared to the prices normally quoted for this kind of analysis which can range from €1000 to €1500. The reason for this large difference is not completely clear, but can partly be explained by the fact that scientist labour and general laboratory costs and calibrants are not included. Costs for QA add another 20-40% to the price taking into account that in every series a blank and reference material (shewhart control chart for accuracy check) should be analysed.

The latter will presumably add another 25-40% to the costs. It should be noted that the information was obtained from research laboratories rather than routine laboratories. Laboratories that operate under routine conditions have optimised their analysis costs in various ways. They have atomised a considerable part of the process, thereby reducing the amount of costly labour. In this way, routine laboratories can offer a sample analysis for a price of €600 (dr. P. Behnisch, personal communication), being considerably lower than the prices offered by research laboratories.

The costs for the techniques developed within DIFFERENCE are lower than the GC-HRMS costs or at the low end of the range GC-HRMS laboratories. CALUX analysis cost around €240, GC-LRMS/MS costs around €250-350 and GCxGC-ECD cost around €900. The latter is more expensive than the reference technique. This is mainly due to the currently labour intensive integration of chromatograms which takes much time due to the low levels in food samples and the integration software. Manufacturers are rapidly developing software which will lead to easier integration of chromatograms and reduction of the labour involved. On the other hand, environmental samples with higher contamination levels are easier to integrate, thereby reducing the amount of labour involved in the final stage.

Costs for calibrants only determine 1-3% of the analysis price.

Instrument costs are highest for GC-HRMS. Per analysis, this will cost around €50 for the GC-HRMS depreciation only. Also the costs for the Fluid Management System is considerable: the instrument costs are about €20 per sample and the consumable costs are around €80 per sample. However, since considerably less labour costs are involved, the overall costs for clean-up and fractionation using this technique is lower compared to the conventional techniques.

A big step forward is obtained by ASE extraction in combination with within-cell clean-up. With this approach ready-to-inject extracts are obtained for costs around €120, whereas for the classical extraction and clean-up techniques, these costs are around €150-300. A further advantage is that the time required for selective-ASE is just a few hours of preparation of the samples and extraction cells in the laboratory, whereas for the classical strategies normally at least 4 days are required to perform these steps. This makes selective ASE a strong alternative for routine analysis as well as in times of crisis.

Final remarks

The cost for a GC-HRMS analysis can be in the same range compared with e.g. GC-LRMS, based on the calculations above. Therefore, it may seem that the purchase and use of a GC-HRMS is preferred over other techniques. However, the investment of a GC-HRMS is much higher (€350000-400000) compared to GC-Ion trap MS/MS (€60000), making it more difficult for laboratories to purchase, for financial reasons.

CALUX is slightly cheaper than GC-HRMS and has the main advantage that in times of crisis, this screening method can easily be scaled up because the clean-up and determination are rather simple and easy to perform. Therefore, when a high throughput is required, this method complements the reference technique. A small drawback of CALUX is the license costs which determine 13% of the analysis cost.

Finally, the ASE instrument requires an investment of ca €60000. The investment is easily earned back as one can cut dramatically on labour costs.

4.3.9 Conclusions

Table 19 shows an overview of the results of round 1 and 2.

Table 19. Overview of the performance of the different techniques

Parameter	GC-HRMS	CALUX	GC-LRMS/MS	GCxGC-ECD
Goodness-of-fit	++	+	++	+
Repeatability	++	+	++	+
Reproducibility	++	+/-	++	+
Accuracy	++	+/-	++	+/-
Detection capability	+	+/-	++	+/-
Selectivity	++	+/-	++	+

CALUX

The CALUX results of round 1 and 2 were promising, taken into account that the results of the CALUX technique were not corrected for recovery, while the results obtained by the GC-labs were all corrected for recovery by the use of internal standards or isotopic dilution. The repeatability of the CALUX technique is around 15% for the milk and the fish oil samples. The intermediate precision is higher (up to 38%). The CALUX technique is an excellent screening technique provided the labs can find a way to correct for the recovery and can control and possibly further reduce the variation. It should be mentioned that a reduced variation will automatically lead to a much lower minimum detectable value. Lab E has already an MDV (= 0.9 pg TEQ/g oil) close to the MDV of one of the GC-HRMS labs. A second issue that should be addressed by the CALUX labs is the sensitivity of the method for dl-PCBs. The low REP values for the dl-PCBs cause an underestimation of the PCB-TEQ. In round 3 it was observed that the CALUX results, when not corrected for recovery, mostly underestimate the total TEQ concentration in the samples. Applying recovery correction results in a better correlation with the GC-HRMS results. However, it should be stressed that even with recovery correction the results from CALUX deviate sometimes substantially from the GC-HRMS results. The within-lab reproducibility CV's for the CALUX labs which applied recovery correction are mostly below the required 30%.

GC-LRMS/MS

In rounds 1 and 2 excellent results were reported for the GC-LRMS/MS method. Based on these results, this method is a good alternative routine method for the analysis of dioxins and PCBs. The results obtained with this technique were as accurate as the results reported by the labs using GC-HRMS. The repeatability and the intermediate precision of the method is below 7%. The MDV is below 0.36 pgTEQ/g oil. However, this conclusion is only based on the results of one lab. In addition, the time needed to interpret the results has not been evaluated yet. The responsible laboratory has indicated that due to applying expert judgment at low concentrations, the data evaluation part was sometimes rather time-consuming.

The results of the GC-LRMS/MS screening technique in round 3 were satisfactory. The variation for all the samples is smaller than 6%. The bias (for total TEQ) of GC-LRMS/MS is small.

GCxGC-ECD

Lab I* has produced mostly satisfactory Z-scores with GCxGC-ECD. The MDV of this lab is below 1,4 pg TEQ/g oil. However, the GCxGC-ECD results reported by lab K were not that good. It should also be mentioned that the initial results submitted by lab I (note that I* are the corrected results of I) tend to overestimate the dioxin concentration in the samples. This is in particular caused by the somewhat higher LODs which play an important role in the upperbound calculation. Their weight in this upperbound calculation is relatively higher than in an upperbound calculation with GC-HRMS. Due to the software quality (better GCxGC software quality is being developed at the moment) and the sensitivity problems of the μ -ECD, the data evaluation is extremely time consuming at the moment. As soon as a reliable automatic integration could be applied, the GCxGC technique will become more interesting for use for the dioxin analysis. At higher dioxin levels, such as in environmental samples, it is already now feasible to apply this technique.

The results of the GCxGC-ECD screening technique in round 3 were satisfactory. The within-lab CV's for the GCxGC-ECD labs are below the required 30%. A more pronounced bias is observed for GCxGC-ECD. The differences between the laboratories for the dioxin-TEQ and PCB-TEQ values are larger than for the total TEQ.

Two other screening techniques for dioxins and dl-PCBs, GC-LRMS/LVI and the Ah-PCR technique, were also included in this project. However, it was impossible to construct a dose response curve with the data submitted for GC-LRMS/LVI. The Ah-PCR is still being developed and no data for rounds 1 and 2 could be reported.

Cost evaluation

On a routine basis (100 samples/month), the costs for a GC-HRMS analysis is surprisingly lower than normally quoted in the market. The GC-HRMS costs vary from ca €280 to €500. The CALUX costs are below €250, whereas GC-LRMS/MS is around €350. GCxGC-ECD is currently rather expensive (€1000), mainly due to the complexity of the software. It is expected that this situation will improve over the next few years resulting in a decrease of labour costs during the integration of the chromatograms.

A considerable improvement is obtained with selective-ASE, which combines extraction, clean-up and fractionation within one cell, thereby reducing the labour costs as well as time needed for performing these steps. It is a rather simple technique that requires limited instrumentation. This technique can deliver ready-to-analyse extracts for each final determination technique, thereby further reducing analysis costs.

In terms of investment, GC-HRMS requires a 5-6 fold investment compared to GC-LRMS/MS. Furthermore, it requires more laboratory space than a bench-top GC-LRMS/MS.

CALUX is a very valuable screening technique that is complementary to the reference technique. In times of crisis, when high throughputs are required, CALUX can easily scale up to meet the increased demands.

Selective-ASE combined with GC-LRMS/MS is a strong combination for those laboratories that cannot afford to buy a GC-HRMS. Selective-ASE in combination with CALUX is a strong combination for those laboratories that would like to run a screening technique or in times of crisis.

Milestones and deliverables

The following milestones and deliverables have been met:

D8	Validation protocol
D4	Report on screening method performance
M5	Start of method development
M6	Method developed and optimised
M7	Start of interlaboratory study
M8	End of first interlaboratory study
M9	Interlaboratory study completed

4.4 Work package 4: Test certification

The objective of WP-4 was to assess the feasibility of the certification of new reference materials for dioxins and PCBs in food and feed.

The specific objectives of WP4 were:

- to conduct an interlaboratory study on PCDD/Fs, dioxin-like PCBs and indicator PCBs in the five proposed materials, with 10-15 expert laboratories applying the GC-HRMS (gas chromatography - high resolution mass spectrometry) confirmatory technique for analysis of PCDD/Fs and dioxin-like PCBs, and evaluate whether a sufficient level of agreement between the laboratories can be reached to make a future certification project likely to succeed for the whole range of analytes;
- to further assess the performance characteristics of some chemical and bioanalytical screening techniques, by including them in the interlaboratory study, and investigate their capability to serve in a certification project.

4.4.1 Task 14. Preparation of protocols and T 15 Instruction of participants

After the final selection of the participants and the preparation of a draft protocol and reporting forms, an introductory meeting was organised (CSIC, Barcelona, Spain, 9-10 October 2003) to inform the participants, discuss the protocol and reporting forms, and agree upon practical aspects such as the time frame and quantity of sample needed. In view of the amount of analytical work to be performed, it was decided to organise the actual interlaboratory study in two rounds; in addition this created the possibility to eliminate shortcomings in the protocol, reporting forms and/or analytical methods prior to the second round.

In the protocol designed for the interlaboratory study and discussed with the participants prior to the experimental work, particular attention was given to the following subjects:

- number and independency of replicate determinations;
- compounds and materials to be analysed;
- storing conditions of materials upon receipt;
- guidelines for taking representative subsamples;
- calibration (purity of standards, use of internal standards, working range);
- traceability of data obtained;
- determination of recovery and extraction efficiency;
- determination of the procedure blank;
- determination of matrix characteristics such as the lipid content or dry matter content;
- deadline and reporting instructions.

Detailed forms, based on Word and Excel tables, were prepared to facilitate the reporting and subsequent data collection by the coordinator.

During the technical meeting after the 1st round, some modifications to the protocol and reporting forms were agreed upon, and incorporated in an adapted version for the 2nd round. Both versions of the protocol, and an example of the reporting forms, are included as Annex of the report on the feasibility of certification Annex 4.

4.4.2 Task 16. Analyses interlaboratory study

During the 2nd half of 2003 and 2004, the participating laboratories have analysed the samples according to the protocols discussed above.

4.4.3 Task 17. Statistical evaluation

4.4.3.1 Discussion of the overall performance

In Table 20 an overview of the overall performance in this feasibility study is presented; analytes were classified according to type of compound, and further according to the relative uncertainty (U_{rel}) of the consensus value. The following conclusions can be drawn:

- in general somewhat smaller relative uncertainties were obtained for milk and compound feed than for the other matrices;
- the worst comparability was observed for pork tissue, which also was the only material in which no consensus value could be reached for one of the important congeners with regard to TEQ contribution (PCB 126);

- a similar level of comparability was reached for the wet fish tissue and the fish oil;
- overall, for 65% of the parameters the half-width of the 95% confidence interval was less than 10% of the mass fraction, and for 80% of the parameters less than 15% of the mass fraction;
- even though for some congeners only a “less than” value could be proposed, this hardly has any effect on the calculated TEQ values (difference between upper and lower bound TEQ is less than 2%).

Table 20. Overall performance, according to group of compounds and relative uncertainty of the consensus values

	fish tissue DIFF-01	pork tissue DIFF-02	whole milk DIFF-03	fish oil DIFF-04	compound feed DIFF-05
# PCDD/F congeners					
Urel ≤ 5%	1	2	4		
5% < Urel ≤ 10%	5	4	12	8	10
10% < Urel ≤ 15%	6	4		2	5
15% < Urel ≤ 20%	1	3			
Urel > 20%		1		2	
indicative value	1	2	1	1	2
“less than” value	3	1		4	
# DL-PCB congeners					
Urel ≤ 5%	1		3	2	2
5% < Urel ≤ 10%	8	7	6	7	7
10% < Urel ≤ 15%	1	2	2	2	
15% < Urel ≤ 20%	1				
Urel > 20%	1	1			1
indicative value		2	1		2
“less than” value				1	
# indic PCB congeners					
Urel ≤ 5%	2		1	2	2
5% < Urel ≤ 10%	4	5	3	3	3
10% < Urel ≤ 15%		1		1	
15% < Urel ≤ 20%					
Urel > 20%					
indicative value			2		
“less than” value					1

The relative uncertainties on a congener basis are graphically shown in Figure 9 to Figure 11. Indicative or “less than” values, or relatively large uncertainties ($U_{rel} > 15\%$), are observed more than once for the following congeners (ranked according to decreasing number of such values):

- O_8 CDD and O_8 CDF
- 1,2,3,4,6,7,8- H_7 CDD, 1,2,3,7,8,9- H_6 CDF, PCB 114 and PCB 123
- 1,2,3,4,6,7,8- H_7 CDF, 1,2,3,4,7,8,9- H_7 CDF and PCB 28

These congeners consequently may be regarded as the most demanding for certification. Likely technical reasons are the very low concentration of some of these compounds (especially when compared to others from the same compound group) as well as higher sample contamination risks.

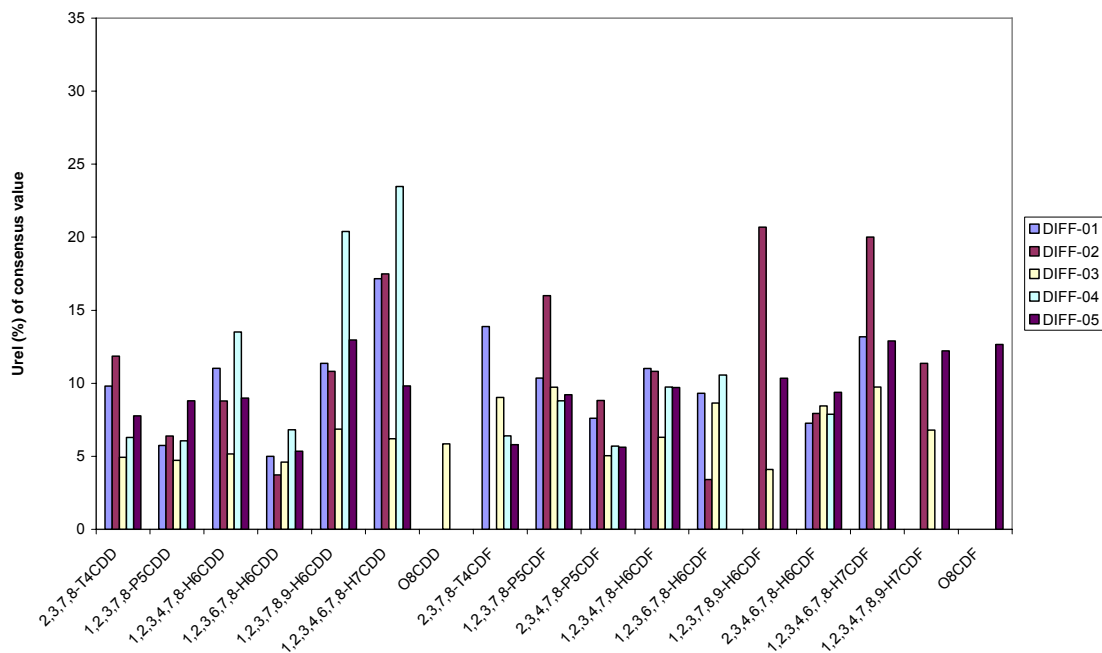

Figure 9. Relative uncertainties of the consensus values for PCDD/F congeners

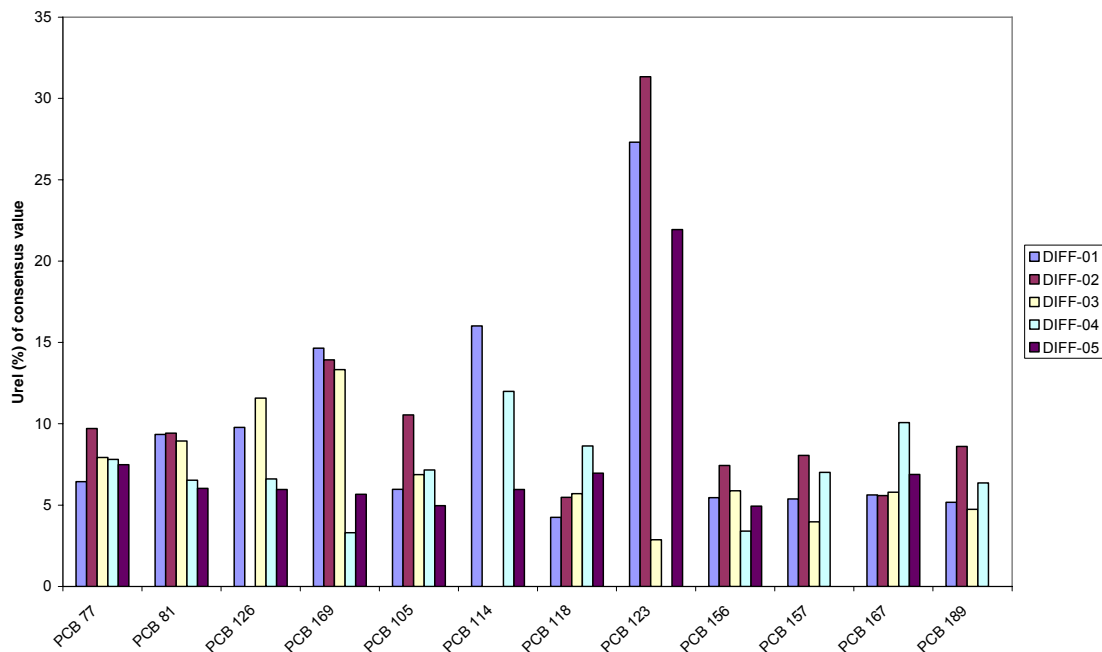

Figure 10. Relative uncertainties of the consensus values for dioxin-like PCB congeners

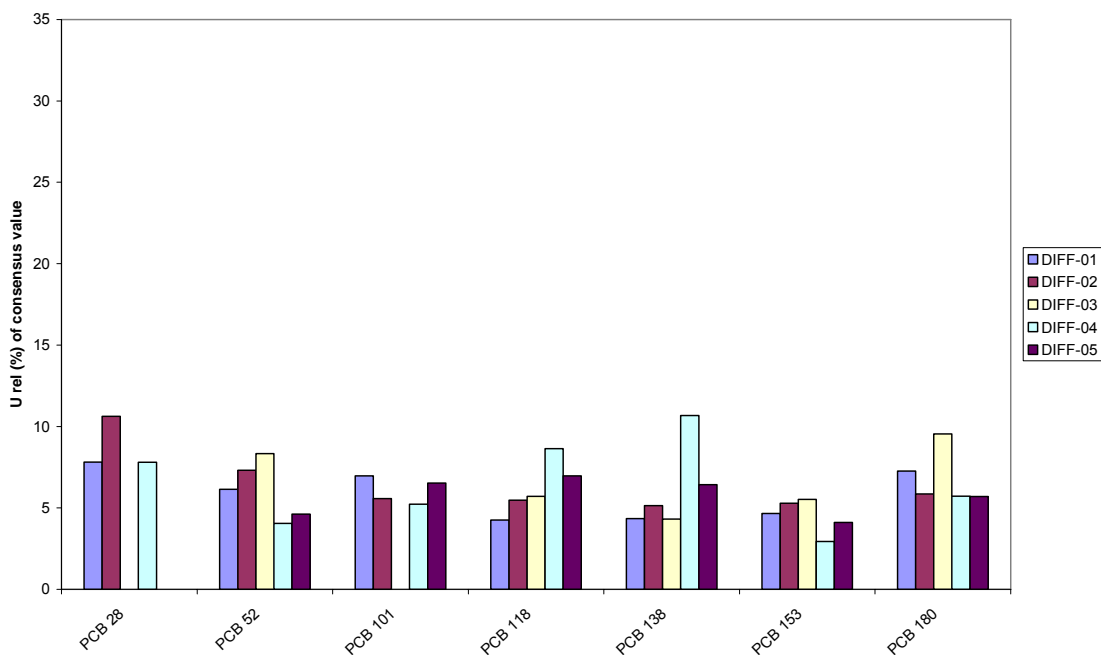

Figure 11. Relative uncertainties of the consensus values for indicator PCB congeners

4.4.3.2 Evaluation of the PCDD/F-TEQ determination by GCxGC-ECD, GC-LRMS/MS and CALUX

All labs applying the GC-HRMS confirmatory method apparently comply with the criteria in the EC regulation, with exception of a few labs for fish/pork tissue. There were doubts about the extraction procedure applied by these labs, and their data have not been used for the calculation of the consensus values.

The biases observed for the various screening techniques are summarized in Figure 12.

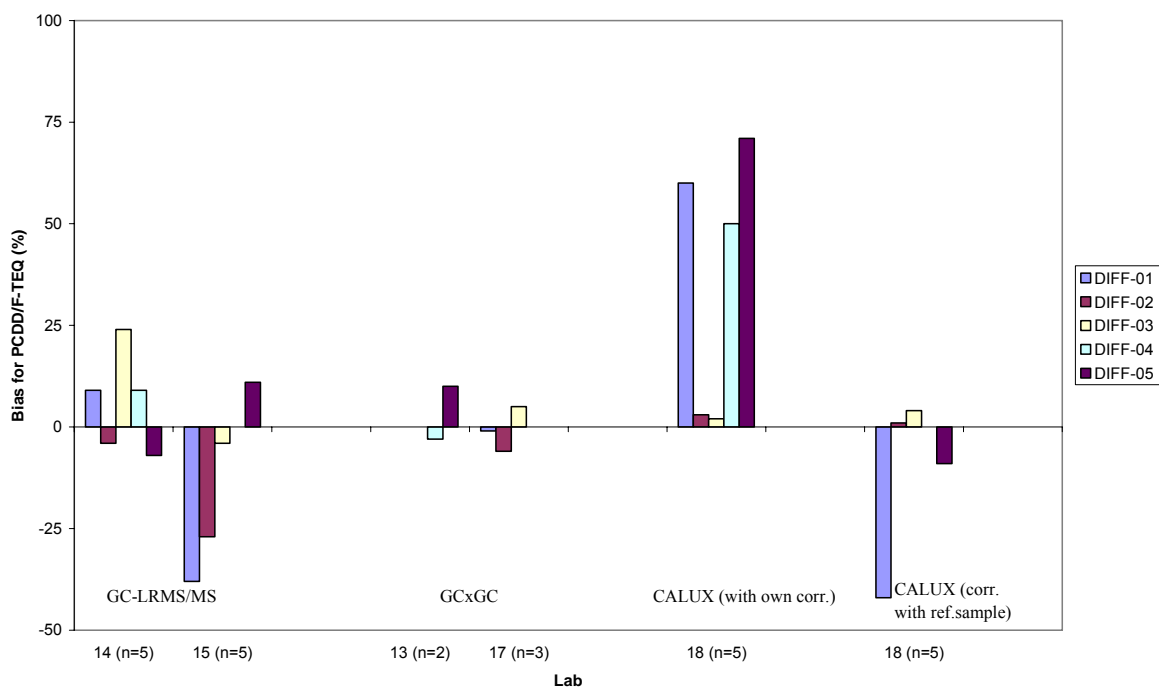

Figure 12. Bias for PCDD/F-TEQ obtained with various screening methods. The labnumbers are mentioned on the x-axis (together with the number of repetitions).

It can be concluded that the chemical screening techniques GC-LRMS/MS and GCxGC (with ECD or TOFMS detection) yield very good PCDD/F-TEQ estimates. Only one of the CALUX labs determined the PCDD/F fraction separately; when using a reference sample to correct for recovery, it also obtains very good biases except for fish tissue, where apparently some overcorrection occurred. The usual approach for recovery correction by this lab, based on scintillation counting of a ^{14}C -TCDD spike to a separate sample which undergoes the extraction and purification procedure, provided correct results for milk and pork tissue, but a ca. 50% overestimation of the PCDD/F-TEQ of the other materials.

Figure 13 shows the within-lab precision observed for the various screening techniques. Only in one case (GCxGC-TOF) the limit set for screening methods is slightly exceeded. The GC-LRMS/MS technique is able to achieve a similar precision as the confirmatory method, but the performance may strongly depend on the working conditions of the lab. On an overall basis, there is no clear relation between the within-lab precision and the matrix analysed.

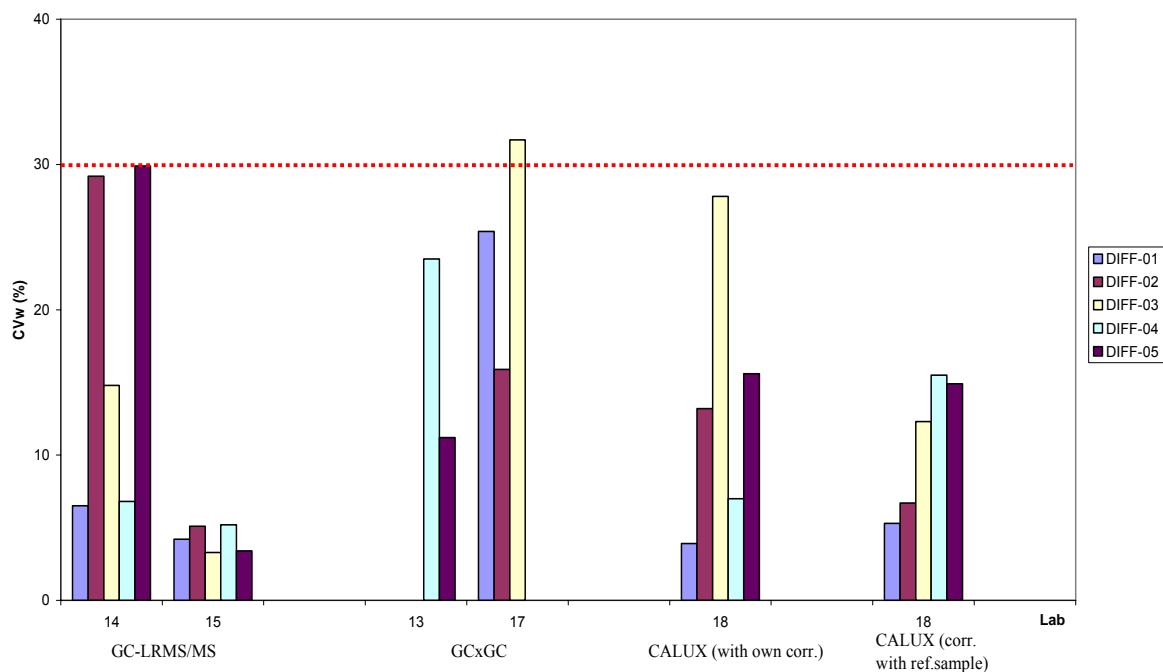

Figure 13. Within-lab precision for PCDD/F-TEQ obtained with various screening methods

4.4.3.3 Evaluation of the total TEQ determination

For the total TEQ determination by GC-HRMS, the same conclusions about compliance with the criteria in the EC regulation can be drawn as for the PCDD/F-TEQ determination. In this feasibility study, the within-lab precision for the total TEQ by GC-HRMS generally was slightly better than for the PCDD/F-TEQ (Figure 14).

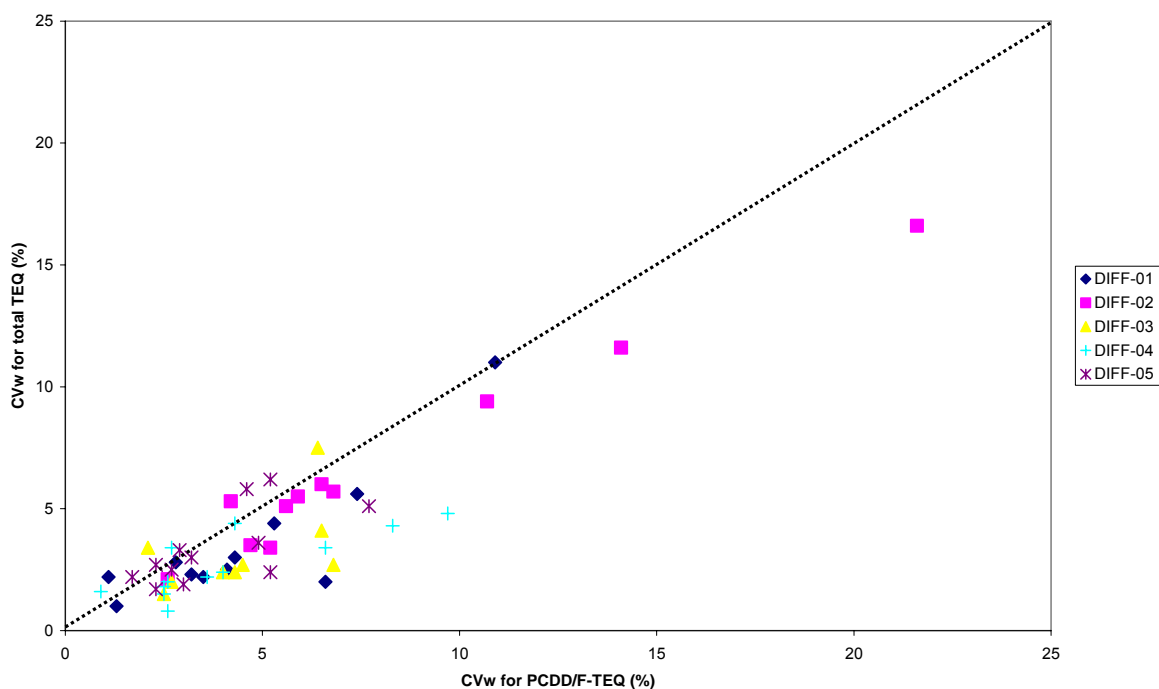

Figure 14. Within-lab precision by GC-HRMS for total TEQ vs. PCDD/F-TEQ

The biases observed for the various screening techniques are summarized in Figure 15.

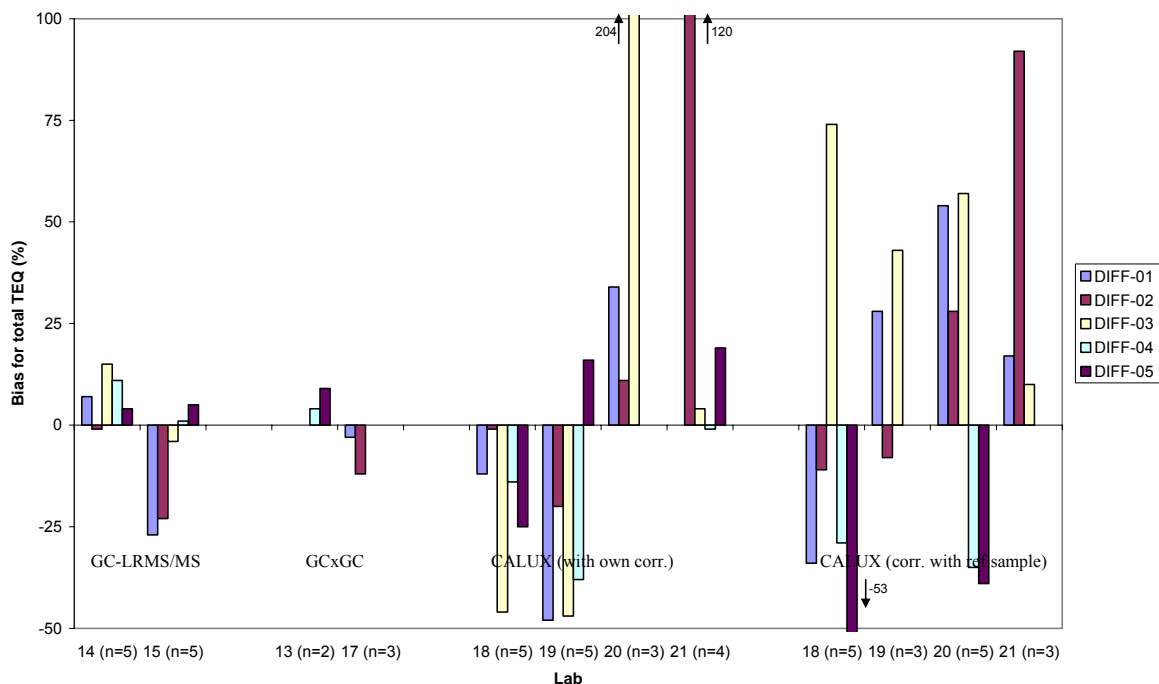

Figure 15. Bias for total TEQ obtained with various screening methods

Similarly as for the PCDD/F-TEQ, the chemical screening techniques GC-LRMS/MS and GCxGC (with ECD or TOFMS detection) yield very good total TEQ estimates, taking into account that the underestimation by lab 15 for fish and pork tissue is not due to limitations of the instrumental technique (cf. evaluation of PCDD/F-TEQ determination).

The biases observed for the CALUX bioassay appear highly variable. Lab 18 tends to get negatively biased total TEQ estimates after its usual recovery correction based on samples spiked with ¹⁴C-

TCDD, and the alternative correction approach based on a reference sample doesn't improve the performance. Lab 19 applied two different approaches for the own correction, based on a TCDD standard solution for DIFF-04 and -05 and a spiked beef fat for DIFF-01 to -03; in the latter case also the difference between the WHO-TEFs and the CALUX response factors for the various congeners was taken into account. This results for most materials in negatively biased TEQ estimates; when the recovery correction is based on the reference samples provided, the bias generally seems to improve but some overcorrection may occur. Lab 20 underestimated the total TEQ in the 1st round of the study (DIFF-04 and -05), whereas in the 2nd round a positive bias was obtained after each of both correction approaches. Lab 21, whose usual recovery correction is based on analysis of in-house reference samples, obtained quite small biases for all materials except for the pork tissue; the latter seems related to a high blank contribution. It may be concluded that with the CALUX bioassay an acceptable bias can be obtained; however, to improve and assure the comparability of data, further standardisation of the method (including recovery correction) and the availability of suitable reference materials (whose matrix and congener profile match those of the samples analysed) seem to be needed.

Figure 16 shows the within-lab precision observed for the various screening techniques. Only for CALUX the limit set for screening methods is exceeded in some cases. When the recovery correction is based on a reference sample, also CALUX complies with the target CV level (the only remaining nonconformity is probably related to an occasional blank problem). The GC-LRMS/MS technique is able to achieve a similar precision as the confirmatory method, but the performance may strongly depend on the working conditions of the lab. Also the within-lab CV for total TEQ estimates by GCxGC methods remains well below the 30% limit for all the matrices investigated in this feasibility study.

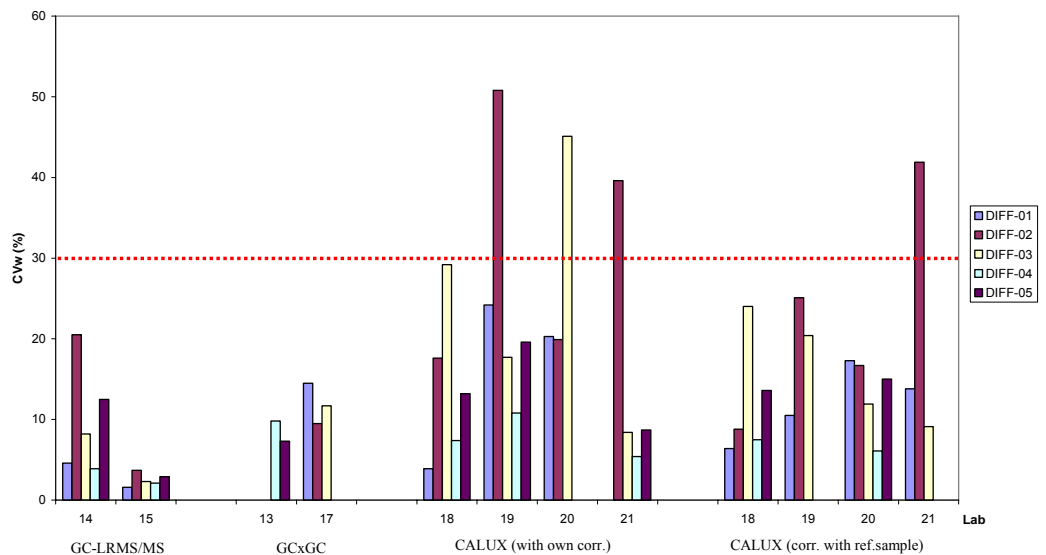

Figure 16. Within-lab precision for the various screening techniques

4.4.4 Task 18. Evaluation meetings

During evaluation meetings attended by representatives of the participating laboratories, the analytical methods used and the results of the interlaboratory study were discussed to confirm the reliability and verify the traceability of the data. These meetings were organised on April 15-16 2004 (Antwerp, Belgium) and November 15-16, 2004 (Brussels, Belgium).

In view of the Directives 2002/69/EC and 2002/70/EC, it was agreed upon that the consensus values and their uncertainties for PCDD/Fs and dioxin-like PCBs in the candidate CRMs should rely only on results obtained with the reference method GC-HRMS. Data obtained by screening techniques were used to further evaluate the performance of these techniques.

4.4.5 Task 19. Report feasibility certification

The report including the results and the discussion can be found in Annex 4.

4.4.6 Recommendations for a future certification study

This feasibility study has demonstrated that the participating group of expert laboratories should be able to reach fit-for-purpose uncertainties in a future interlaboratory certification trial, and this for most - if not all - of the 35 compounds of interest. A comprehensive protocol agreed upon prior to the measurements and a thorough technical discussion of the methods and results afterwards, must be considered critical factors to make a certification succeed. In the protocol, it is recommended to pay particular attention to the following points:

- the independency of the replicate analyses : depending on the compromise taken, part of the random errors of a typical determination may not be reflected by the within-lab RSDs (resulting in an increased risk of outlying variances), and also lab means may become affected by additional small systematic errors (resulting in an increased risk for outlying lab means at the 0.05 significance level);
- the extraction efficiency from wet tissues (fish, pork, ...): this feasibility study indicates that apolar solvents may not always completely extract the analytes from the matrix, even when recoveries for internal standards and the amount of fat extracted do not suggest any problem;
- the procedure blanks: because of the ultratrace level at which some of the analytes are present in food and feed, the procedure blank is nonnegligible in many labs; it should be carefully quantified to enable a reliable correction, and a limit on the contribution of the procedure blank to the result is recommended;
- the chromatographic separation : on the currently used GC columns, it is likely that some analytes cannot be sufficiently resolved from other analytes or coeluting compounds to enable an accurate peak integration; some critical pairs are the 1,2,3,4,7,8/1,2,3,6,7,8-H₆CDD and H₆CDF isomers, PCB 118/123, PCB 167/128, PCB 28/31, PCB 138/163; however, also for other congeners (e.g. PCB 114) possible coelution has been noticed in this feasibility study; the recovery of internal standards : for GC-HRMS, the Directives 2002/69/EC and 2002/70/EC have set 60-120% limits to the recovery (with an exception for PCDD/F congeners which together contribute less than 10% to the PCDD/F-TEQ); the results of this feasibility study suggest that particularly the lower limit cannot easily be met when multi-step cleanup schemes are applied, but that recoveries somewhat below 60% generally do not affect the reliability of results for food and feed samples; the amount of internal standards added and the spiking method (conditioning, ...) may be more important factors.

4.4.7 Conclusions

- The feasibility study showed that it is feasible to certify the five materials (milk, pork, fish tissue, fish oil and compound feed). This conclusion is based on the fact that for a considerable number of PCDD/F, dl-PCB and ndl-PCBs congeners satisfactory narrow 95% confidence intervals could be achieved using the GC-HRMS data only.
- In some cases, no consensus value could be determined. This could be due to e.g. very low levels (< LOQ values) or an interference (e.g. for PCB 123). For some congeners only a "less than" value could be proposed.
- An upperbound and lowerbound TEQ value could be determined based on the consensus values. No uncertainty has been determined due to the complex nature of calculation of this uncertainty.
- GCxGC-ECD and GC-LRMS/MS generated accurate data which is comparable to the GC-HRMS data. The data meets in nearly all cases the EU criteria laid down in (EC 2002) and (EC, 2002). This confirms the conclusions drawn in WP-3. For CALUX the within-lab precision bias were more substantial and in some cases did not meet the EU criteria. However, recovery correction could considerably improve the results.

Partners involved

VITO was responsible for WP-4. The other partners (RIVO, RIKILT, IIQAB-CSIC, CARSO, IPH, Umea University, Lund University and subcontractor UB) have been participating in the interlaboratory study (task 16) and have analysed the candidate CRMs. Besides the partners, external laboratories participated in this study by using their in-house GC-HRMS, CALUX, GCxGC-ECD and GC-LRMS/MS methods, thereby enlarging the dataset of the different methods.

Milestones and deliverables

The following milestones and deliverables have been met:

- D6 Report on feasibility of certification
- M9 Interlaboratory study completed

4.5 Work package 5: Extraction and clean-up methods

The objective of WP 5 was to develop and optimize an automated standard extraction and clean-up methodology starting from the test of three different techniques: Supercritical Fluid extraction (SFE), Microwave-Assisted Extraction (MAE) and Accelerated Solvent Extraction (ASE). All three techniques have been evaluated as described in the objectives, but already at an early stage, it was discovered that ASE was the superior technique, and most efforts were therefore made to develop and standardize this methodology.

The aim was to standardize at least one methodology, which should be capable of quantitatively extracting all PCBs, dioxins, and furanes from different matrix types. The aim of standardizing a new extraction/ clean-up methodology was to provide European dioxin laboratories with a less solvent consuming, faster, simpler and, in addition, more cost-effective method, requiring less man power but with increased sample throughput. The aim was fulfilled since the developed selective ASE method is suitable for standardization as was demonstrated in interlaboratory tests, which are discussed below

4.5.1. Design of the study and partners involved

1. The first part of the study was devoted to optimize the extraction conditions for the different techniques. Partners Lund University and Umeå University evaluated the SFE technique, partners Lund University and JRC-IRMM evaluated the MAE technique, and partners Lund University and JRC-IRMM evaluated the ASE technique. At a later stage, Lund University and Umeå University got involved in the development of a more sophisticated ASE approach, based on an idea originating from the Umeå University laboratory.
- 2a. The second part of the study dealt with automated clean-up methodologies. Partners Lund University and Umeå University evaluated SFE, while all partners evaluated ASE. At a later stage, Lund University and Umeå University got involved in the development of a more sophisticated ASE approach, based on an idea originating from the Umeå University laboratory. For MAE, on-line clean-up approaches are not possible.
- 2b. Performance characteristics of ASE and SFE were evaluated using different well-known matrices as well as external reference materials.
3. ASE combined with GC-HRMS and combined with CALUX was evaluated in the interlaboratory studies of WP-3. Furthermore, the performance of ASE was tested in WP-4 (test certification). Neither SFE nor MAE was evaluated in WP-3 or 4 (for ASE was the most promising method).

Results and discussion

4.5.2 Task 20. Development and optimization of SFE.

This technique offers a great deal of selectivity but at the same time requires a relatively extensive optimization in order to be successful. After some initial experiments within the DIFFERENCE project, SFE was not given priority mainly because there is a lack of good commercial instruments. Some of the most useful methods developed previously had been utilizing a Hewlett-Packard 7680T, but this instrument has been withdrawn from the market. A second reason for not focusing on SFE was that the cell volumes of the available SFE instrument are too small to allow extraction of sufficient materials of low contaminated matrices. Even so, it was decided that the consortium should spend some time on demonstrating the potential and selectivity of SFE. Two different extraction strategies were therefore evaluated.

l). The first method was based on a selective extraction of PCBs and dioxins, leaving the fat behind in the extractions cell. This was accomplished by the utilization of a fat retainer such as basic alumina in the extraction cell. This fat retainer allows for the analytes to be extracted in a fat-free "window", and the size of this window depends on the amount fat in relation to the amount of fat retainer in the cell. In Task 20, a previously developed method was evaluated where all PCBs and dioxins were collected on the same solid-phase trap (van Bavel, Jaremo et al. 1996). In this case, the trap was packed with a combination of octadecyl silica and active carbon. By doing so, the collected analytes could be group-separated on the trap and each fraction could be directly injected with no further sample clean-up needed. The packing of the extraction cell in this investigation is shown in Figure 17.

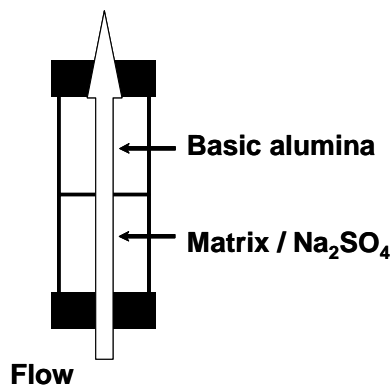

Figure 17. Packing of the extraction cell in the investigation of SFE with on-line fat removal and trapping of PCBs and dioxins on a combined octadecyl-silica / active carbon trap according to van Bavel et al (1996).

The results from the evaluation of this methodology are shown in Figure 18 in which the concentrations obtained for PCBs and dioxins in a number of matrices such as fishmeal, and fish oils are compared to previously obtained reference values.

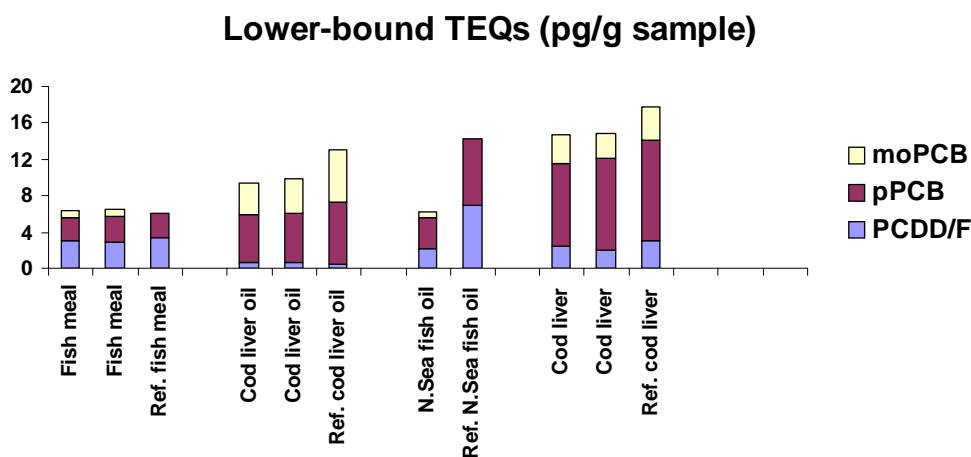

Figure 18. Comparison of PCB and dioxin concentrations obtained with the packing procedure in Figure 1, using a combined octadecyl-silica / active carbon trap according to van Bavel et al (1996), and previously obtained reference values. GC-HRMS was used for quantification.

These new “DIFFERENCE-concentrations” are in good agreement with previous reference data. It demonstrates the strength of SFE for certain types of highly contaminated matrices, producing extracts that are directly ready for analysis without further clean-up when on-line fat removal is combined with trap packing materials such as active carbon. It also verified the feasibility of the already existing method presented by van Bavel *et al.* (1996) for these matrix types.

II). The second developed method in Task 20 performed a simultaneous extraction of both indicator-PCBs and fat, which were collected on a home-built prolonged solid-phase trap, packed with Florisil. Thereafter, the PCBs were selectively eluted with n-heptane followed by elution of the fat using a combination of n-heptane/acetone. This allowed for a simultaneous fat and PCB determination in the same sample. The elution profiles of PCBs and fat on the prolonged solid-phase trap, extracted from a spiked pork meat, is seen in Figure 19.

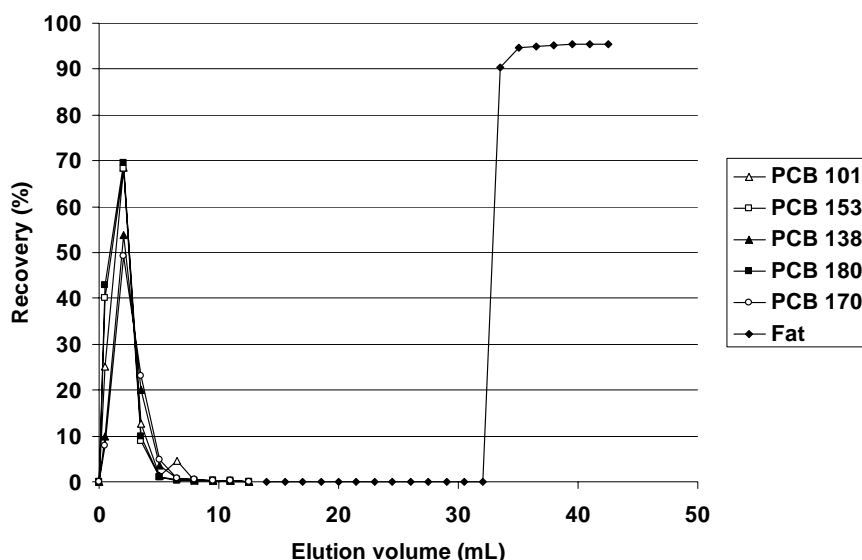

Figure 19. Elution profile of PCBs and fat from a prolonged solid phase trap packed with Florisil. The analytes were extracted from spiked pork meat at 100°C for 60 min, 275 bar. Trap elution of PCBs was performed with 30 mL n-heptane and of fat with 15 mL n-heptane/acetone (1:1 v/v). GC-ECD was used for quantification.

The PCB recoveries were about 95% and the fat recovery of triglycerides (extractable lipids) was also quantitative. A similar method was developed for fishmeal, which required somewhat harsher extraction conditions to recover all fat. The main goal of these exercises was to develop a single method capable of determining concentrations of indicator-PCBs and fat with a minimum of sample handling. However, since major focus was given to ASE already at an early stage of the project, the research has instead resulted in two different methods and scientific papers, one for pork fat and similar matrices (Ahlström, Westbom et al. 2005) and one for fish matrices Supercritical fluid extraction of PCBs and fat from fish matrices with on-line separation on a long solid phase trap (Sporring and Björklund Manuscript) which both are in the manuscript stage. None of the developed methods was evaluated in the interlaboratory tests.

4.5.3 Task 21. Development and optimization of MAE.

The main merit of MAE is the possibility of performing many extractions simultaneously. Unfortunately, the selectivity is rather poor as the amount of co-extracted fat is hard to remove by using fat retainers. Consequently, external clean-up steps are required. The reason for MAE being unsuitable for on-line clean-up approaches is that MAE performs batch type extractions while SFE and ASE utilize dynamic extraction steps with flowing solvents. Even so, MAE can perform many extractions per unit time and this was the rationale behind the work initiated to optimize a method under Task 21. It is also advantageous that there are a number of commercial instruments on the market.

It was decided to use an experimental design to find the optimal extraction conditions for indicator-PCBs. However, before choosing starting values, a thorough literature study was performed and a number of parameters were listed as being important. A total of 22 experiments were performed in the design to investigate the influence of temperature, time, solvent volume, and sample size. Three different matrices were investigated (fishmeal, feed for poultry and vegetable feedstuff) resulting in some 66 extractions. The final evaluation of this data set revealed problems in accuracy, and some attempts were done to perform additional clean-up of extracts and to retake a few experiments, but without success. Recently it was revealed that the accuracy problem was revealed that the accuracy problem was only present in first part of the data set, while the second halves of experiments were fine. Based on the second data set it could be concluded that also MAE works for extracting PCBs from feed matrices, and a short communication has just been submitted to *Chromatographia* (Ahlström, Sparring et al. 2005) (Annex 19). The results from extracting seven indicator PCBs from three feed matrices can be seen in Figure 20.

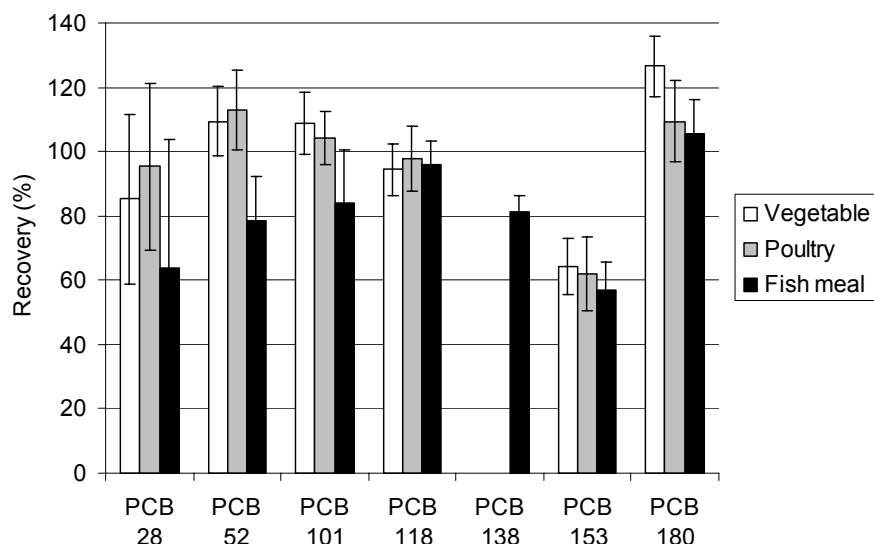

Figure 20. Recoveries of PCBs extracted from vegetable cattle feed, feed for poultry and fishmeal using *n*-heptane/acetone (1:1, v/v) at 75°C for 15 min. Error bars indicates RSDs (n=6). PCB 138 was excluded from vegetable cattle feed and feed for poultry since no certified value exists for this congener. GC-ECD was used for quantification.

Even so, the lack of possibilities of performing on-line clean-up led to that this technique was abandoned in favour of the very promising ASE technique.

4.5.4 Task 22. Development and optimization of ASE.

This technique is today one of the most potent ones for obtaining fast and quantitative extractions of PCBs and dioxins in food and feed. Furthermore, there are good and well-supported instrumentations commercially available. Therefore, most research activities have been devoted to develop methods utilizing this technique as part of DIFFERENCE in order to streamline the sample preparation step. Three different extraction strategies have been evaluated.

I) The initial method was a non-selective extraction of indicator-PCBs, where all fat and pollutants were extracted simultaneously. Consequently, the extracts required clean-up prior to analysis. Since there was a limited amount of information available in the literature regarding extraction conditions, a statistical design was performed with a total of 24 experiments. This revealed the influence of temperature, solvent and flush volume on the extraction efficiency. Three different matrices were investigated (fishmeal, feed for poultry and vegetable feedstuff) resulting in 72 extractions. Based on these results a method was suggested for non-selective extractions.

Non-selective ASE method:

100°C 100 bar n-Heptane 5 min 2 cycles 60% Flush volume

Details of this method, and its development, can be found in a recently accepted manuscript that will be published in *Chromatographia* in April 2005 (von Holst, Müller et al. 2005) (Annex 20).

II) The second method studied is a selective method for extracting PCBs and dioxins, in which the pollutants are extracted while the fat is trapped in the extraction cell by applying a fat retainer. This method was based on previous research articles in combination with the results obtained during the development of the non-selective ASE method above. The developed method was tested on several certified reference materials and the proposed method was very similar to the non-selective method:

Selective ASE method:

100°C 100 bar n-Heptane 5 min 2 cycles 60% Flush volume
 Fat retainer : Sulphuric acid Fat-to-Fat Retainer Ratio (FFR): 0.025

Details about this method, and how it was developed, can be found in a recently published paper in *Journal of Chromatography A* 2004 (Sparring and Bjorklund 2004) (Annex 21) and in a manuscript that is in a late stage of preparation (Sparring and Bjorklund). The packing of the extraction cell in this method is shown in Figure 21.

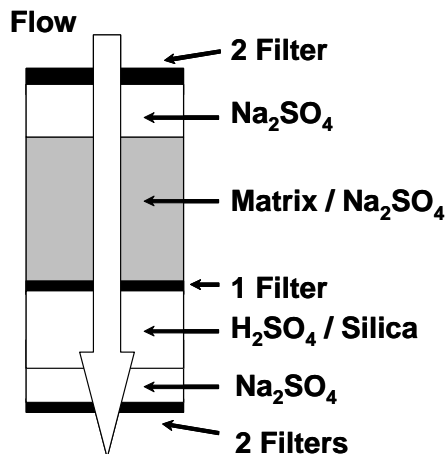

Figure 21. Packing of the extraction cell in the selective ASE method with on-line fat removal using sulphuric acid impregnated silica according to Sporrying et al. (2004).

The results from the evaluation of this selective extraction methodology are shown in Figure 22, in which the concentrations obtained for PCBs and dioxins in vegetable oil and fish oils using pressurized liquid extraction (PLE) with in-line fat removal are compared to concentrations obtained after classical extraction.

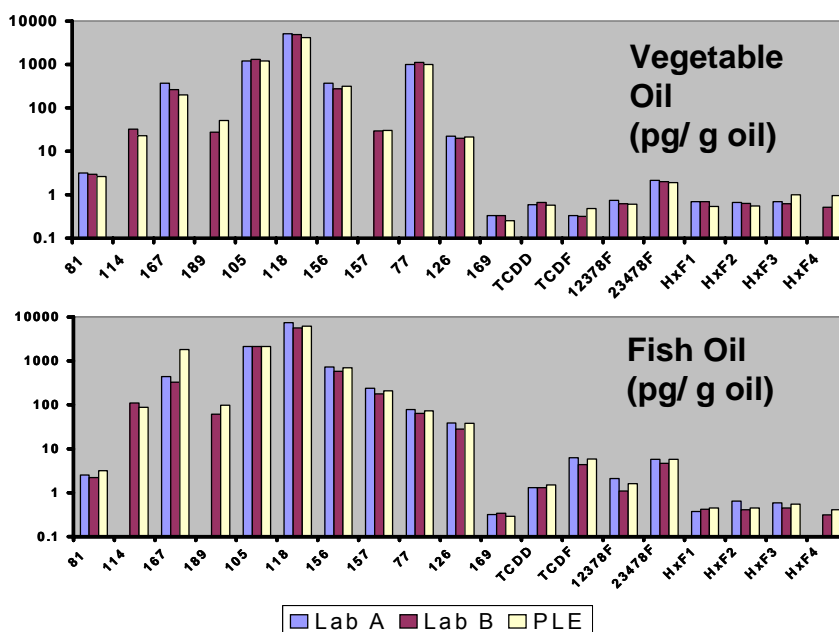

Figure 22. Comparison of PCB and dioxin concentrations obtained with the packing procedure in Figure 20 using selective PLE with on-line fat removal by sulphuric acid impregnated silica (PLE) and concentrations obtained with conventional dioxin analyses using classical extraction procedures (Lab A and Lab B). In all cases GC-HRMS was used for quantification.

The data presented in Figure 22 were part of the interlaboratory study rounds 1 and 2, which are discussed in more detail in (Van Loco, Van Leeuwen et al. 2004),. In that paper, it was concluded that the selective ASE method is a valid alternative extraction and clean-up procedure, comparable to but much faster than classical techniques. The reason for this is that the fat free extracts could be analyzed on HRMS after fractionation and only a minimal additional sample clean-up. The extracts could also be directly subjected to the CALUX assay. In both cases could the ASE results not be statistically distinguished from the classical extraction methods. However, in round 3 it was observed that the within-lab reproducibility CV's of the ASE+GC-HRMS method (extraction and clean-up followed

by GC-HRMS analysis) for pork tissue and chicken feed samples were significantly higher than the CV's of the GC-HRMS method with a classical extraction and clean-up procedure. Still, they were below 30%. Part of this is related to an unidentified carry-over effect somewhere along the sample preparation chain for these particular samples. Unfortunately, no time was available to find the source of this variation. During round 3, questionable Z-scores were observed for the chicken and herring sample. There are very strong indications that this is an effect of insufficient water removal in the sample preparation step of the tissues since too little sodium sulphate was used in the homogenisation procedure in order to save space in the extraction cells. Consequently, the *n*-heptane could not penetrate the wet matrices properly, causing bad recoveries. New samples have been extracted with appropriate amounts of sodium sulphate present. The final results from these experiments are underway, probably demonstrating the feasibility of the developed ASE method also for these matrices. The egg samples were not extracted since liquids are not suitable for extraction in ASE as it requires large amounts of sodium sulphate to keep it in the cell. Extraction of the sepiolithic clay sample was not successful, which is not surprising since pure alkanes are not strong enough solvents to remove analytes from active sites in these types of matrices. Consequently, no data were reported for egg and sepiolithic clay. However applying conventional ASE with appropriate solvents at high temperature is still a valid alternative to replace the extraction step such as Soxhlet, even though on-line clean-up approaches then are not so simple to achieve.

At a late stage of the DIFFERENCE project, an even more sophisticated extraction strategy for PCBs and dioxins was developed based on an idea originating from Umeå University. In this case, special inserts were placed in 34 mL extraction cells to perform shape-selective, fractionated extraction procedures inside the cells. The inserts were designed and produced in-house, and they allowed a small carbon column to be integrated into the extraction cell according to Figure 23.

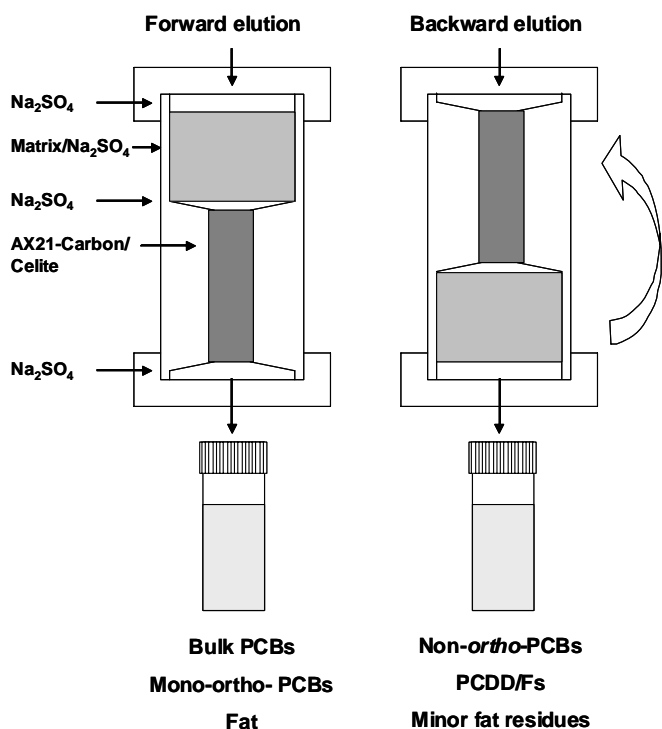

Figure 23. Shape-selective extraction/fractionation using special inserts packed with active carbon. Extractions were performed on Dionex system ASE300 using 34 mL cells at 100°C with different solvents.

The ultimate goal was to extract and fractionate the samples within the ASE-cell, whereby bulk PCBs and mono-*ortho* PCBs were aimed to be collected in forward elution and non-*ortho* PCBs and PCDD/Fs in backward elution. The first experiment was carried out with spiked fish oil, and it showed that the non-*ortho* PCBs eluted too early, already during forward elution, which presumably was caused by a too small carbon column (see Error! Reference source not found. below). Forward elution consisted of two fractions. Fraction 1, where only *n*-heptane was used, extracting most of the

fat, the bulk PCBs, the mono-*ortho* PCBs and some non-*ortho* PCBs, while fraction 2 consisted of DCM/*n*-heptane (1:1 v/v), extracting the remaining of the non-*ortho* PCBs. In backward elution a third fraction was used consisting of toluene, extracting the PCDD/Fs after the cell had been turned upside down in the system.

By using these special inserts, traditional carbon column fractionation of the extract was not necessary anymore. To determine the PCDD/F content of the samples, only a small miniaturized multilayer silica column clean up of the toluene fraction in backward elution was required after the ASE prior to detection. Although these initial experiments did not fractionate all analytes according to our intention, this method is still useful as a routine screening method for the analysis of dioxin-TEQs. When extracting a naturally contaminated fish meal and spiked fish oil, the toluene fraction in backward elution could successfully be analysed by the CALUX bioassay resulting in dioxin TEQs equivalent to those obtained by GC-HRMS and CALUX after traditional extraction and clean-up. This is shown in Figure 24, which is part of a recently accepted scientific paper within DIFFERENCE by Nording et al. (Nording, Sporning et al. 2005) (Annex 22). Thus, the integrated ASE-carbon fractionation in combination with a CALUX bioassay shows great potential for a fast and cost-efficient estimate of dioxin-TEQs.

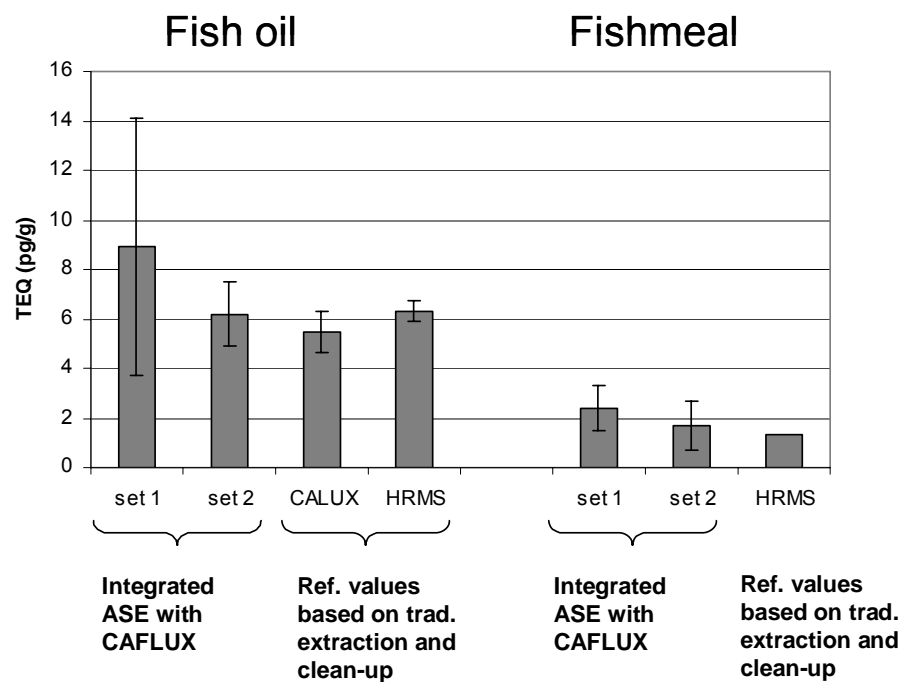

Figure 24. Dioxin content (pg TEQ/g sample) in fish oil and fishmeal determined with different methods. Set 1 and set 2 refer to analyses based on extractions with ASE followed by CALUX ($n = 3$). The CALUX and HRMS values (lower bound TEQs) for the fish oil were produced within the EU DIFFERENCE project based on traditional extraction and clean-up procedures ($n = 6$). For the fishmeal, the HRMS values (lower bound TEQs) are based on traditional extraction and clean-up procedures ($n = 1$) performed at Environmental Chemistry, Umeå University. Error bars correspond to one standard deviation ($n = 3$). Data from Nording et al. (2005).

Since the initial cell-inserts that were made for the 34 mL cells did not provide sufficient shape-selective fractionation, new inserts were produced for the 66 mL cells according to Figure 25.

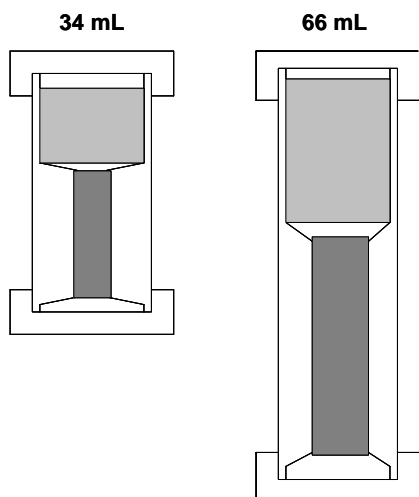

Figure 25. Comparison of inserts for the initially used 34 mL cells and the more recent 66 mL cells. Packing of the cells are identical to that presented in Figure 23.

These new inserts allowed for a larger amount of active carbon to be added to the cells, and after a series of optimisation rounds, this enlarged carbon trap resulted in a proper separation of the different fractions of a corn oil sample as shown in Figure 26.

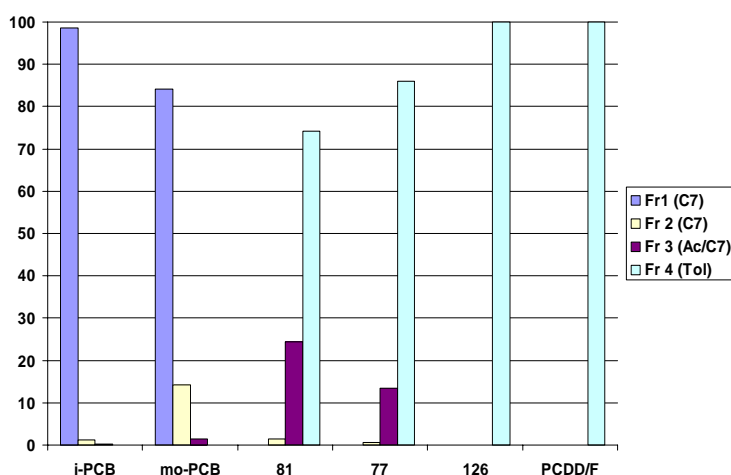

Figure 26. Distribution of PCBs and dioxins in the different fractions using the new insert for 66 mL cells according to Figure 13. Packing of the cells are identical to those presented in Figure 21. Extractions were performed on a Dionex system ASE300 at 100°C with three different solvents. Fraction 1: *n*-heptane (1 cycle), fraction 2: *n*-heptane (1 cycle), fraction 3: acetone/*n*-heptane (1 cycle, Ac/*n*-heptane, 1:1, v/v) and fraction 4: toluene (4 cycles), after the cell has been turned upside down to create a back flush. Each extraction lasted for 5 minutes.

With this set-up, 100% of the indicator-PCBs eluted in forward elution in fraction 1 and 2 together with >98% of the mono-*ortho*-PCBs. At the same time, >98% of the non-*ortho*-PCBs eluted in fraction 3 (forward elution) and 4 (backward elution), as the dioxins did. In the future, only two fractions will be collected as pictured in Figure 26; the first including two cycles of *n*-heptane (forward elution), and the second including one cycle of acetone/*n*-heptane (forward elution) and a number of cycles of toluene (backward elution). The acetone/*n*-heptane is needed for extraction of the minor portion of polar lipids (if any), and thus both fractions needs to be included in the fat determination. The next step is to carry out a validation of this new methodology. However, this will not be achieved within the frame of the DIFFERENCE-project.

4.5.5 Conclusion

Task 20. Development and optimization of SFE.

Already at an early stage of the project, it was known that SFE was not the most promising technique, but it was still decided by the consortium to demonstrate some of the potential and selectivity of SFE. This was achieved by verifying the applicability of the previously developed method by van Bavel et al. (1996) for PCBs and dioxins in highly contaminated matrices utilizing on-line fat removal combined with solid-phase trapping on octadecyl silica/ active carbon. The second approach of a simultaneous extraction/fractionation of indicator-PCBs and fat on a prolonged solid-phase trap packed with Florisil was also shown to be useful. Both methods resulted in extracts that could be analyzed without any additional sample clean-up causing a substantial decrease of the overall time spent on sample preparation. In case better suited instrumentation would become available in the future, SFE might still be a competitive technique.

Task 21. Development and optimization of MAE.

The strength of MAE is simultaneous extraction that can be carried out with commercially available equipment. However, on-line clean-up is not possible in these batch types of static extractions, and therefore, a separate clean-up is required. Since ASE was shown to be a very promising technique it was concluded that more research activities were not justified.

Task 22. Development and optimization of ASE.

The ASE (PLE) technique has provided two useful and competitive methods within the DIFFERENCE-project. The selective extraction procedure using sulphuric acid impregnated silica is a good alternative to classical extraction and clean-up methodologies as was demonstrated in an international validation study. This method provides lipid-free extracts. Only a separate carbon-fractionation together with a miniaturised sample clean-up has to be performed in addition to prepare ready-to-inject dioxin and PCB extracts. The shape-selective extraction fractionation combining PLE with integrated carbon fractionation together with a CALUX bioassay shows great potential for a fast and cost-efficient estimate of dioxin-TEQs. The results suggest that the quality criteria on screening methods for the control of PCDD/Fs in foodstuffs, which have been laid down in EU Commission Directive 2002/69 /EC, can be met. This would be a very useful tool in new cases of food and feed contamination as well as for routine control of a large number of samples at lowered costs. Finally, the latest contribution with larger cell-sizes with integrated carbon-fractionation is a major technical step forward since it allows for a combined shape-selective extraction and fractionation resulting in a cost-efficient and high throughput extraction clean-up procedure, which is fully according to the objectives in the DoW.

Milestones and deliverables

The following milestones and deliverables have been performed:

- D7. Report on extraction and clean-up methods
- M10. Start of extraction/clean-up study

4.6 Work package 6: Standardisation

The objective of WP-6 is to standardise the methods that are developed within WP-3 (detection techniques) and WP-5 (extraction). Furthermore, the implementation of the new methods can be stimulated by contacts through international certification bodies like CEN.

4.6.1 Task 24. Validation protocol

The methods that have been developed and optimised within WP-3 and WP-5 are subjected to an extensive validation protocol. The methods are tested for linearity, limit of detection, accuracy, robustness etc. GC-HRMS serves as the reference method throughout the validation. The results of the validation are statistically evaluated according to international protocols.

The validation protocol, which is subdivided in three rounds, can be found in Annex 6.

4.6.2 Task 25. Standardisation of methods

At an early stage in the project, contacts have been established with CEN for exploration of the standardisation of the methods that have been developed, optimised and validated within this project. At a later stage in the DIFFERENCE project, the results of the validation showed that standardisation of methods is feasible.

Currently, the activities on the standardisation are ongoing (and will continue after finalisation of the project). The CEN Committee is very interested in the presentation of a proposal concerning the screening and confirmatory methods for the determination of PCDD/Fs and dl-PCBs in feed and foodstuffs. A meeting of the technical Committee TC/275 will happen on 2-3 June 2005 at Berlin. During this meeting, there is an opportunity to present and to discuss the standardisation protocol for the methods CALUX, GC x GC – ECD and GC – LRMS and the reference method GC – HRMS. Partners will supply standardised information on their methods which will be joined by the WP-leader resulting in a standardisation protocol for discussion in the CEN technical Committee TC/275. For that purpose, the partners are requested to deliver the information on their methods in a standardised form (Annex 23). In the meantime, a proposal for a protocol has been prepared by the WP-leader (Annex 24) which will be discussed with the partners involved. After reviewing of the proposal, a finalised version will be sent to the CEN Technical Committee TC/275 for discussion.

4.6.3 Task 26. Report on standardisation

The work within this work package will continue after finalisation of the project. The report of the work performed consists of the protocol that will be submitted for the CEN Technical Committee TC/275 meeting of 2-3 June 2005.

4.6.4 Conclusions

A proposal is being prepared for discussion at the international standardisation body CEN. This proposal includes analysis protocols using the following techniques CALUX, GC x GC – ECD and GC – LRMS and the reference method GC – HRMS. The proposal will be discussed at the Technical Committee TC/275 (2-3 June 2005).

Activities on the standardisation will continue after finalisation of the project.

Partners involved

The work on the standardisation has been carried out mainly by IPH. The partners provide their detailed method information for inclusion in the protocol.

Milestones and deliverables

M12. Standardisation of methods completed

4.7 Work package 7: Dissemination

The objective of this WP is to disseminate the knowledge generated in the project to a broad (scientific) audience and to policy makers. Dissemination took place through:

- web-site
- newsletter
- flyer
- logo
- scientific publications and presentations
- workshop for training laboratory staff
- video/DVD for education and promotion purposes

The DIFFERENCE project has a strong relation to the DIAC project and therefore it was decided to collaborate closely with the DIAC project in the dissemination of both projects by the web-site, logo and newsletter. The **logo** of the DIFFERENCE project and DIAC projects show similarities in design. From the artist point of view, the two blue and red circles represent the substituted fenyl groups which are connected by the centre circle representing the bonds between the two fenyl rings. The logo is used on the web-site, newsletters, presentations and internal communication within the consortium. The logo and web-site have been developed by the sub-contractor Frisse Wind (Amsterdam, The Netherlands).

4.7.1 Task 27. Scientific publications, platform presentations and posters

- Abalos, M. *et al.*, Ion trap MS/MS vs. HRMS for the analysis of PCDD/Fs and dioxin-like-PCBs in food samples, *Organoh. Comp.* 60 (2003): 452-455, 2003.
- Ahlström, L.-H., Westbom, R., Sporning, S., Björklund, E. Utilization of a supercritical fluid extractor coupled on-line to a prolonged solid phase trap for simultaneous extraction and separation of PCBs and lipids from a model fat sample and meat reference material, *manuscript*.
- Ahlström, L.-H., S. Sporning, C. von Holst, E. Björklund, Microwave-Assisted Extraction of Seven Selected Polychlorinated Biphenyls from Feed Samples, *Chromatographia*, submitted
- Björklund, E., Sporning, S. New strategies for extraction and clean-up of persistent organic pollutants from food and feed samples using pressurized liquid extraction, *Trends in Anal. Chem.*, 2005, *Submitted*.
- Carbonnelle, S., Joris Van Loco, Ilse Van Overmeire, Isabelle Windal, Nathalie Van Wouwe, Stefan Van Leeuwen, Leo Goeyens, Importance of REP values when comparing the CALUX bioassay results with chemoanalyses results. Example with spiked vegetable oils. *Talanta* 63 (2004): 1255-1259.
- Sophie Carbonnelle, Joris Van Loco, Rudy Van Cleuvenbergen, Stefan Van Leeuwen, Ilse Van Overmeire, Isabelle Windal, Nathalie Van Wouwe, Leo Goeyens, Comparison of the results obtained by CALUX bioassay and GC-HRMS for different matrices, *Organoh. Comp.* 66 (2004): 326-330.
- Danielsson C., Wiberg K., Korytár P., de Boer J. and Haglund P. Trace analysis of PCDD/Fs and WHO PCBs in food and feed using comprehensive two-dimensional gas chromatography (GCxGC). *Organoh. Comp.* 60 (2003): 395-398.
- Danielsson C., Wiberg K., Korytár P., Bergek S., Brinkman U.A.Th, Haglund P. Trace analysis of polychlorinated dibenzo-*p*-dioxins, dibenzofurans and WHO polychlorinated biphenyls in food using comprehensive two-dimensional gas chromatography. *J. Chromatogr. A*, in press.
- Haglund P, Danielsson C, Harju M, Marriott P. "Effects of temperature and flow regulated carbon dioxide cooling in longitudinally modulated cryogenic systems for comprehensive two-dimensional gas chromatography". *J. Chromatogr. A*, 962 (2002), 127-134.
- Haglund P., Wiberg K., Danielsson C., Nording M., Björklund E., Sporning S. "Hyphenated techniques for dioxin analysis: LC-LC-GC-ECD, GCxGC-ECD, and selective PLE with GC-HRMS or bioanalytical detection". *Organohalogen Compounds* 66 (2004), 376-383.
- Harju M, Danielsson C, Haglund P. Comprehensive two-dimensional gas chromatography of the 209 PCBs". *J. Chromatogr. A*, 1019 (2003), 111-126.
- von Holst, C., Müller, A., Serano, F., Sporning, S., Björklund, E. Optimisation of pressurized liquid extraction for the determination of seven selected polychlorinated biphenyls in feed samples, *Chromatographia* (2005), in press.
- P. Korytar, C. Danielsson, P.E.G. Leonards, P. Haglund, J. de Boer, U.A.Th Brinkman. Separation of seventeen 2,3,7,8-substituted polychlorinated dibenzo-*p*-dioxins and dibenzofurans and 12 dioxin-like polychlorinated biphenyls by comprehensive two-dimensional gas chromatography with electron-capture detection, *J. Chromatogr. A*, 1038 (2004), 189-199
- Korytár P., Parera J., Leonards, P.E.G., de Boer J., Brinkman U.A.Th. A quadrupole mass spectrometer operating in electron capture negative ion mode as detector for comprehensive two-dimensional gas chromatography. *J. Chromatogr. A*, 1067 (2005) 255-264
- Korytár P, Leonards, P.E.G., de Boer, J. and Brinkman U A Th., High-resolution separation of polychlorinated biphenyls by comprehensive two-dimensional gas chromatography, *J. Chromatogr. A*, (2002), 958:203-218.
- Korytar, P. *et al.*, GCxGC method development for the analysis of seventeen 2,3,7,8- substituted dioxins, furans and twelve dioxin-like PCBs *Organoh. Comp.* 60 (2003): 355-358.
- Kristenson E.M, Korytár P, Danielsson C, Kallio M, Brandt M, Mäkelä J, Vreuls R, Beens J, Brinkman U A Th., Evaluation of modulators and electron-capture detectors for comprehensive two-dimensional GC of halogenated organic compounds, *J. Chromatogr. A*, 1019 (2003):65-77.
- Van Leeuwen, S.P.J., van Cleuvenbergen, R. and de Boer, WP-4, Trends in Analytical Chemistry, manuscript
- Van Leeuwen, S.P.J., J. van Loco, J. de Boer, DIFFERENCE: Optimisation and validation of screening techniques for the analysis of dioxins and dioxin-like PCBs in food and feed and the production of certified reference materials, *Organohalogen Compounds* 60-65 (2003)
- Van Loco, J., S. Van Leeuwen, P. Roos, S. Carbonelle and H. Beernaert, The International Validation of Bio and Chemical Analytical Screening Methods for Dioxins and Dioxin-like PCBs: The Difference Project Round 1 and 2, *Talanta*. 63 (2004):1169-1182.

- Van Loco, J., S.P.J. van Leeuwen, S. Carbonelle, L. Goeyens, H. Beernaert, The international validation of Chemical and Biological Screening Methods for dioxins and dl-PCB's: The DIFFERENCE Project round 3. *Organohalogen compounds* 66 (2004) 318-325
- Malavia, J., Abalos, M., Santos, F.J., Abad, E., Rivera, J., Galceran, M. T., Ion-trap MS/MS vs. HRMS for the analysis of PCDDs/Fs and dioxin-like PCBs in food samples. *Organoh. Comp.* 60 (2003): 452-455.
- Malavia, J., Abalos, M., Santos, F.J., Abad, E., Rivera, J., Galceran, M. T. Evaluation of tandem mass spectrometry based on ion-trap analyser (ITMS) for the analysis of PCDD/Fs and dioxin-like PCBs in food samples. *Anal. Chem. (Submitted)*.
- Malavia, J., Abalos, M., Santos, F.J., Abad, E., Rivera, J., Galceran, M. T. Gas chromatography ion trap tandem mass spectrometry for the analysis of PCDD/Fs and dioxin-like PCBs in vegetable oil samples. *J. Chromatogr. A, (Submitted)* (2005)
- Malavia, J., Abalos, M., Santos, F.J., Abad, E., Rivera, J., Galceran, M. T. Comparison of GC-HRMS and GC-LRMS/MS as a routine method for the determination of dioxins in food and feed. *Trends in Anal. Chem. (in preparation)* (2005)
- Nording, M., Sporning, S., Björklund, E., Wiberg, K., Haglund, P. Efficient screening of dioxins in food and feed using shape-selective pressurized liquid extraction and cell-based bioassay analysis, *Organoh. Comp.* 66 (2004): 617-622.
- Nording, M., Sporning, S., Wiberg, K., Björklund, E., Haglund, P. Monitoring of dioxins in food and feedingstuffs using accelerated solvent extraction with a novel integrated carbon fractionation cell in combination with a CAFLUX bioassay, *Anal. Bioanal.Chem.*, (2005) *in press*.
- Parera, J., P. Korytár, J. Diaz Ferrero, J. de Boer, P.E.G. Leonards. Comprehensive multidimensional gas chromatography coupled to low resolution quadrupole mass spectrometer for the analysis of PCDDs, PCDFs and PCBs. *Organoh.. Comp.*, 66 (2004) 272-277.
- Santos, F.J., Maliva, J., Abalos, M., Abad, E., Rivera, J. and Galceran, M.T.. Ion trap tandem mass spectrometry: a reliable technique for the analysis of PCDD/Fs and dioxin-like PCBs in food and feed samples. *Organohalogen compounds* 66 (2004) 238-243
- Sparr Eskilsson, C., Sporning, S., Björklund, E. Fast and selective analytical procedures for determination of persistent organic pollutants in food and feed utilizing recent extraction techniques, In: *Modern extraction techniques for food and agricultural samples*, Ed., American Chemical Society, ACS Press, (2005), submitted.
- Sporring, S., Wiberg, K., Björklund, E., Haglund, P. Combined extraction/clean-up strategies for fast determination of PCDD/Fs and WHO-PCBs in food and feed samples using accelerated solvent extraction, *Organoh. Comp.* 60 (2003):1-4
- Sporring, S., Björklund, E. Selective accelerated solvent extraction of PCBs from food and feed samples, *Organoh. Comp.*, 60 (2003):53-56
- Sporring, S., Björklund, E. Selective accelerated solvent extraction of PCBs from fat-containing food and feed samples – influence of cell dimensions, solvent type, temperature and flush volume, *J. Chromatogr. A.*, 1040 (2004):155-161.
- Sporring, S., Björklund, E., Selective pressurized liquid extraction of polychlorinated biphenyls from fat-containing food and feed samples – effects of high lipid amounts and lipid type on fat retention in large volume cells, *manuscript*.
- Sporring, S., Björklund, E. Supercritical fluid extraction of PCBs and fat from fish matrices with on-line separation on a long solid phase trap, *manuscript*.

Platform presentations and posters

- Abalos, M. *et al.*, Ion trap MS/MS vs. HRMS for the analysis of PCDD/Fs and dioxin-like-PCBs in food samples, Dioxin 2003, Boston, USA, August 2003, poster presentation.
- Björklund, E. *et al.*, Combined extraction and clean-up in ASE for the analysis of PCBs and dioxins in food and feed samples, ESAC 2003, Executive Seminars in Analytical Chemistry, Copenhagen, Denmark, April 2003, invited lecture.
- de Boer, J. Developments in methods for the analysis of organic contaminants in fish, , invited lecture, 100 Years ANFACO-CECOPESCA, Viogo, Spain, 19 April 2004
- de Boer, J., Progress of the EU projects DIFFERENCE and DIAC. International Council for Exploration of the Sea (ICES), Berlin, March 2002, oral.
- de Boer, J. Oral. " GCxGC-ECD as an alternative technique for the analysis of dioxins and PCBs in European food control laboratories". 26th international symposium on capillary chromatography and electrophoresis. 19-23 May 2003, Las Vegas, Nevada, USA.

- de Boer, J. Peter Korytar, Pim E.G. Leonards, Stefan P.J. van Leeuwen. 23rd International Symposium on Halogenated Organic & Persistent Organic Pollutants (Dioxin 2003), Boston, USA, August 24-29, 2003.
- de Boer, J., P. Korytár. Invited lecture. Developments in Multi-dimensional GC Techniques for the Determination of Organic Environmental Pollutants. July 2004, South-African National Chemical Convention, Pretoria, South Africa.
- Bordajandi, L.R., P. Korytár, M.J. González, J. de Boer. Comprehensive Two-Dimensional Gas Chromatography for the Determination of Chiral PCBs in Food Samples. 1st International Symposium on Comprehensive Multidimensional Gas Chromatography, March 6-7, 2003, Volendam, The Netherlands.
- Carbannelle, S., Van Loco, J., Van Cleuvenbergen, R., Van Leeuwen, S., Van Overmeire, I., Windal, I., Van Wouwe, N., Goeyens, L., Comparison of the results obtained by CALUX bioassay and GC-HRMS for different matrices, Dioxin 2004, Berlin, Germany, September 2004, poster presentation
- Danielsson* C, Wiberg K, Bergek S, Harju M, Korytár P, de Boer J, Haglund P., Trace analysis of PCDD/Fs and WHO PCBs in food and feed using comprehensive two dimensional gas chromatography (GCxGC), Dioxin 2003, Boston, USA, August 2003, oral.
- Danielsson C, Haglund P. On the separation of 17 toxic congeners of PCDD/Fs and the dioxin-like PCBs using comprehensive two-dimensional gas chromatography. Miljökemiskt vintermöte (Environmental Chemistry Winter Meeting). 12-14 March 2003, Storlien, Sweden, oral.
- Danielsson C, Wiberg K, Haglund P. Poster presentation. "Separation and quantification of 2378-PCDD/Fs and WHO-PCBs using comprehensive two-dimensional gas chromatography". GCxGC '03 – First international symposium on Comprehensive Multidimensional Gas Chromatography, 6-7 March 2003, Volendam, The Netherlands.
- Haglund P, Danielsson C, Harju M, Wiberg K. Oral presentation. "GCxGC av PCB och PCDD/F". Miljökemiskt vintermöte (Nordic Environmental Chemistry Winter Meeting). 12-14 March 2003, Storlien, Sweden.
- Haglund P, Harju M. Oral. "GC-MS or GCxGC?". 25th international symposium on capillary chromatography and electrophoresis, 13-17 May 2002, Riva del Garda, Italy.
- Haglund P, Danielsson C, Harju M. GCxGC of polychlorinated biphenyls, dibenzofurans and dibenzo-p-dioxins. GCxGC '03 – First international symposium on Comprehensive Multidimensional Gas Chromatography. 6-7 March 2003, Volendam, The Netherlands, oral presentation.
- Haglund P, Complete dioxin analyses at low cost – utopia or reality?. Miljökemiskt vintermöte (Environmental Chemistry Winter Meeting). 12-14 March 2003, Storlien, Sweden, oral.
- Haglund, P. *et al.*, Combined extraction/clean-up strategies for fast determination of PCDD/Fs and WHO-PCBs in food and feed samples using accelerated solvent extraction, Dioxin 2003, Boston, USA, August 2003, oral.
- Haglund P, GCxGC TOFMS Applications. 26th International Symposium on Capillary Chromatography. 19-23 May 2003, Las Vegas, USA, oral
- Haglund P., Wiberg K., Danielsson C., Nording M., Sparring S., Björlund E. Hyphenated techniques for dioxin analysis: LC-LC-GC-ECD, GCxGC-ECD, and selective PLE with GC-HRMS or bioanalytical detection, Dioxin 2004, Berlin, Germany, September 2004, oral.
- Haglund P*. Just how good can GCxGC-ECD become for trace-level dioxin and dioxin-like PCB analysis?. 2nd International Symposium on Comprehensive Multi-Dimensional Chromatography (GCxGC). 31 August – 3 September 2004, Atlanta, GA, USA, oral.
- Korytar, P. *et al.*, GCxGC method development for the analysis of seventeen 2,3,7,8- substituted dioxins, furans and twelve dioxin-like PCBs, Dioxin 2003, Boston, USA, August 2003, oral .
- Korytár, P., J. Parera, P.E.G. Leonards, J. de Boer, U.A.Th. Brinkman. Group separation of organohalogenated contaminants by GCxGC. Dioxin 2004, 24th International Symposium on Halogenated Environmental Organic Pollutants and POPs, oral, September 6-10, 2004, Berlin, Germany.
- Korytar, P., L. van Stee, P.E.G. Leonards, J. de Boer, U.A.Th. Brinkman. Analysis of complex mixtures of organohalogenated compounds by comprehensive two-dimensional gas chromatography (GCxGC). Poster presentation, 25th International Symposium on Capillary Chromatography, Riva del Garda, Italy, May 13-17, 2002.
- Korytár, P., A. Covaci, P.E.G. Leonards, J. de Boer, U.A.Th. Brinkman. GCxGC separation of 2,3,7,8-substituted dioxins, furans, and dioxin-like biphenyls from other possibly interfering organohalogenated compounds. Poster presentation, 27th International Symposium on Capillary Chromatography, May 31 – June 4, 2004, Riva del Garda, Italy.

- Korytar, P., Leo L.P. van Stee, E. Maria Kristenson, Luisa R. Bordajandi, Pim E.G. Leonards, Jacob de Boer, Udo A.Th. Brinkman. Modulator selection for comprehensive multi-dimensional GC of dioxins and PCBs. GCxGC '03 – First international symposium on Comprehensive Multidimensional Gas Chromatography, 6-7 March 2003, Volendam, The Netherlands. See Annex 14
- Korytár, P., P.E.G. Leonards, J. de Boer, U.A.Th. Brinkman. Analysis of analysis of polychlorinated dibenzo-p-dioxins, dibenzofurans and dioxin-like polychlorinated biphenyls by comprehensive two-dimensional gas chromatography. Oral, 12th International Symposium, Advances and Applications of Chromatography in Industry, June 29 – July 1, 2004, Bratislava, Slovak Republic.
- Kristenson, E. Maria, Peter Korytar, René J.J. Vreuls, Jan Beens, Udo A.Th. Brinkman. Evaluation and comparison of different modulators in GCxGC for the analysis of organohalogenated compounds. Invited lecture, Analitika 2002, Stellenbosch, South Afrika 2002. Results were also presented (oral) at First International Symposium on Comprehensive Multidimensional Chromatography, Volendam, the Netherlands 2003.
- Malavia, J., Abalos, M., Santos, F.J., Abad, E., Rivera, J., Galceran, M. T, Ion-trap MS/MS vs. HRMS for the analysis of PCDDs/Fs and dioxin-like PCBs in food samples. Dioxin 2003, Boston, USA, August 2003, poster presentation.
- Malavia, J., Abalos, M., Santos, F.J., Abad, E., Rivera, J., Galceran, M. T, Evaluation of gas chromatography-ion trap tandem mass spectrometry for the analysis of PCDD/Fs and dioxin-like PCBs in food samples. 3rd Scientific Meeting of the Spanish Society of Chromatography and Related Techniques, Almería, Spain, November 2003, oral.
- Malavia, J., Abalos, M., Santos, F.J., Abad, E., Rivera, J., Galceran, M. T, GC-Ion trap tandem mass spectrometry as alternative to GC-HRMS for the analysis of PCDDs/Fs and Dioxin-like PCBs. Eighth International Symposium on Hyphenated Techniques in Chromatography and Hyphenated Chromatographic Analyzers (HTC-8), Bruges, Belgium, February 2004, poster presentation.
- Malavia, J., Abalos, M., Santos, F.J., Abad, E., Rivera, J., Galceran, M. T, Ion-trap tandem mass spectrometry: a reliable technique for the analysis of PCDD/Fs and dioxin-like PCBs in food and feed samples. Dioxin 2004, Berlin, Germany, September 2004, poster presentation.
- Malavia, J., Abalos, M., Santos, F.J., Abad, E., Rivera, J., Galceran, M. T, GC-MS/MS con trampa de iones: una técnica adecuada para el análisis de PCDD/Fs y Dioxin-like PCBs en alimentos. II Reunión de Espectrometría de Masas (II-REM Barcelona, Spain, November 2004, poster presentation.
- van Leeuwen, S.P.J. *et al.*, DIFFERENCE: optimization and validation of screening methods for the analysis of dioxins and dioxin-like PCBs in food and feed and the production of certified reference materials, Dioxin 2003, Boston, USA, August 2003, oral.
- van Leeuwen, S.P.J., J. van Loco, P. Korytar and J. de Boer, Optimisation and validation of screening methods for the analysis of dioxins and dioxin-like PCBs in food and feed - "DIFFERENCE", Oral, 1st International Symposium on Recent Advances in Food Analysis, 5-7 November 2003, Prague, Czech Republic
- Nording M., Sporning S., Wiberg K., Björklund E., Haglund P. Efficient screening of dioxins in food and feed using shape-selective pressurized liquid extraction and cell based bioassay analysis. Dioxin 2004, Berlin, Germany, September 2004, oral.
- Nording M, Sporning S, Wiberg K, Björklund E, Haglund P. Screening of dioxins with PLE and analysis with a cell-based bioassay. Nätverket Renare mark, höstmöte (Network Cleaner Soil, autumn meeting), 26-27 October 2004, Linköping, Sweden. poster presentation.
- Parera, J., P. Korytár, J. Diaz Ferrero, J. de Boer, P.E.G. Leonards. Comprehensive multidimensional gas chromatography coupled to low resolution quadrupole mass spectrometer for the analysis of PCDDs, PCDFs and PCBs. Poster presentation, Dioxin 2004, 24th International Symposium on Halogenated Environmental Organic Pollutants and POPs, September 6-10, 2004, Berlin, Germany.
- Parera, J., P.Korytár, F.J. Santos, M.T. Galceran, P.E.G. Leonards, J. de Boer, U.A.Th. Brinkman. Comprehensive multi-dimensional gas chromatography for the characterisation of polychlorinated n-alkanes. Oral, 4th Scientific Meeting of the Spanish Society of Chromatography and Related Techniques, October 5-7, 2004, Madrid, Spain.
- Sporring, S. *et al.*, Selective accelerated solvent extraction of PCBs from food and feed samples, Dioxin 2003, Boston, USA, August 2003, poster presentation
- Sporring S., Wiberg K., Björklund E., Haglund P. On-line ASE extraction and fractionating of polychlorinated dibenzo-dioxins (PCDDs), polychlorinated dibenzo-furans (PCDFs) and dioxin-like PCBs (WHO-PCBs) in feed samples, 27th International Conference on Capillary Chromatography, Riva del Garda, Italy, May, 2004.

- Sporring, S. *et al.*, Selective accelerated solvent extraction of PCBs from food and feed samples, DanSAK8, 8th Danish Symposium in Analytical Chemistry. KVL, Copenhagen, Denmark, August 2004, poster presentation.
- Sporring, S. *et al.*, Accelerated solvent extraction of PCBs, polychlorinated dibenzo-dioxins, and polychlorinated dibenzo-furans in food and feed Samples. DanSAK8, 8th Danish Symposium in Analytical Chemistry. KVL, Copenhagen, Denmark, August 2004, oral.
- Sporring S, Wiberg K, Björklund E, Haglund P. Oral presentation. "Combined extraction / clean-up strategies for fast determination of PCDD/Fs and WHO-PCBs in food and feed samples using accelerated solvent extraction" . Oral, 23rd International Symposium on Halogenated Environmental Organic Pollutants and POPs, 25-29 August 2003, Boston, MS, USA.

* Mikael Harju, Conny Danielsson and Peter Haglund won the John B. Phillips award at the 2nd International Symposium on Comprehensive Multi-Dimensional Chromatography. Conny Danielsson has also won a student award for his work and presentation on the work on detection of dioxins and dioxin-like PCBs with GCxGC, and Peter Korytar was nominated for this award on his work on column selections for GCxGC. These prizes clearly show the attention and the appreciation of the scientific community for the quality of this project.

4.7.2 Task 28. Workshop

The final workshop at which the results of DIAC and DIFFERENCE have been presented, was held at 13 January 2005 in Hotel Carrefour in Brussels. An invitation, including the program of the workshop (Annex 25) has been sent by e-mail to over 1000 persons (EU and national government representatives, scientists, food and feed producing companies etc.). Ca 70 persons, including several EU representatives and the external expert panel, attended the workshop. The program is shown below. All participants received a folder including abstracts of the lectures, the participants list, the brochure and newsletters as well as a copy of the film "A world of DIFFERENCE". A CD with all presentations was sent to all participants afterwards.

9.00-9.30 Registration and coffee

9.30 Welcome

Dr. Jacob de Boer, Netherlands Institute for Fisheries Research, IJmuiden, The Netherlands

9.40 The need for increased capacity in monitoring of dioxins and dioxin-like PCBs in Europe

Dr. Frans Verstraete, DG Sanco, EU, Brussels, Belgium

10.10 Presentation of the film "A world of DIFFERENCE"

10.40 Coffee break

11.10 The potential of comprehensive GCxGC-ECD

Dr. Peter Haglund, Umeå University, Umeå, Sweden

11.35 GC-LRMS/MS as an alternative for GC-HRMS

Dr. Xavier Santos, University of Barcelona, Barcelona, Spain

11.55 The application of CALUX as a screening technique

Prof. dr. Leo Goeyens, Scientific Institute of Public Health, Brussels, Belgium

12.20 Reduced extraction and clean-up time by using accelerated solvent extraction (ASE)

Dr. Erland Björklund, Lund University, Lund, Sweden

12.45 Lunch

14.00 Performance of the alternative techniques compared to GC-HighRes MS

Dr Joris van Looco, Scientific Institute for Public Health, Brussels, Belgium

14.25 Cost evaluation of the alternative methods

Mr. Stefan van Leeuwen, Netherlands Institute for Fisheries Research, IJmuiden, The Netherlands

14.45 Candidate Reference Materials

Dr. Rudy van Cleuvenbergen, VITO, Mol, Belgium

15.05 Expectations of application of the alternative techniques in a routine dioxin laboratory

Mr. Wim Traag, RIKILT, Wageningen, The Netherlands

15.25 Coffee break

15.45 Introduction of the discussion: Future developments (GCXGC software, standardisation in CEN, etc.)

Dr. Jacob de Boer (Netherlands Institute for Fisheries Research, The Netherlands)

16.00 Discussion

16.30 Closure of the meeting and drinks

4.7.3 Task 29. Video/DVD preparation

The production of the film has started after the first meeting (26-27 June 2003) with mr. T. McInnes of Callisto productions in collaboration with RIVO. Furthermore, a production schedule has been produced. Production meetings have taken place at the following dates 25/26 June 2003 (Aberdeen), 10/11 September 2003 (at RIVO) and 10 May 2004 (at RIVO). The actual filming at RIKILT, RIVO and some other places (supermarket and waste incinerator) has taken place from 27 September to 1 October 2004. At 29 September, prof. dr. U. A. Th. Brinkman, dr. F. Verstraete, mr. W.A. Traag, prof. dr. J. de Boer and prof. dr. F.X.R. van Leeuwen were interviewed in front of the camera. The day after, a large number of scenes were recorded with ms. Kate Sanderson (a UK news presenter) as presenter. After the shooting, the post production phase started. The editing was done in Glasgow (29, 30 November 2004) together with J. de Boer and S. van Leeuwen (RIVO). The film production was finalised and 1500 copies of the CD (Annex 28) were made and arrived at RIVO around mid January 2005.

The film has been presented at the DIFFERENCE/DIAC workshop of 13 January 2005 in Brussels. Furthermore, the CD has been sent to a suite of international contacts. The coordinator received various positive responses at the workshop and through e-mails from contacts that received the CD by post (Annex 28).

4.7.4 Task 31. Training course

A training course has been organised for representatives of food control laboratories. Laboratories selected were from 15 EU countries excluding the countries that were already involved as partner in the DIFFERENCE project and the new member states (Table 21). Some additional participants were also interested in the trainings and it was decided that they could participate, but on their own expense. Trainees could choose between CALUX, GC-LRMS/MS and GCxGC-ECD training.

Table 21. Participants of the CALUX, GCxGC-ECD and GC-LRMS/MS training.

Participant	Institute	City	Country	Training
Arvid Fromberg	Danish Inst. Food & Veterinary Research	Soborg	Denmark	GCxGC
Renate Tritschler	Chemisches und Veterinäruntersuchungsamt	Freiburg	Germany	CALUX
Paulo Antunes			Portugal	GCxGC
Igor Fochi		Rome	Italy	LRMS/MS
Jaana Koistinen	National Public Health Institute	Kuopio	Finland	LRMS/MS
Philip Bersuder*	CEFAS	Burnham on Crouch	UK	LRMS/MS
Pierrick Fevrier	State Laboratory Chemisches und Veterinäruntersuchungsamt	Dublin	Ireland	LRMS/MS
Alexander Kotz*	Veterinäruntersuchungsamt	Freiburg	Germany	CALUX

* Participation on own expenses.

The training for the CALUX method has been performed by RIKILT at their laboratories on 27/28 January 2005. The training of the GCxGC-ECD method took place on 27/28 January 2005 at the

RIVO laboratory. The training of the GC-LRMS/MS method was initially also planned in January – March 2005. However, due to problems with the GC-LRMS/MS instrumentation and moving the laboratories of the subcontractor University of Barcelona, the training has not taken place. Alternatively, in the near future possibilities for training of the GC-LRMS/MS participants, together with representatives of the 10 new member states will be explored. Possibly, EU DG Enlargement can provide financial compensation for that training. Initial contacts with DG Enlargement were positive but follow-up on this is required.

4.7.5 Task 31. Web-site

The web-site has been produced in the early stages of the project (see overview of deliverables). The web-sites of DIAC and DIFFERENCE are accessible via www.dioxins.nl. The web-site shows the consortium, the aims of the project, work packages and planning, background information on techniques, obtained results, relevant literature and possibilities to contact the coordinator and to receive the newsletter every six months. After the initial establishment, the web-site has been updated regularly. The web-site is regularly visited (circa 1,000 hits per month). Visitor statistics show visitors from North America, Europe and Asia. 85% of the visitors visit the web-site by coincidence (via different search engines like 'Google' etc.) and left the website within 1 minute. However, the remaining 15% stayed 2-60 minutes at the web-site indicating that they were attracted by the information shown. The web-site will be maintained to at least 31 December 2006 to ensure an ongoing broad dissemination of the two projects.

A special password protected section was only accessible to the partners and the scientific EU officer. At this section of the website all relevant files of the project including presentations, results, progress reports and minutes of meetings could be found.

4.7.6 Task 32. Other exploitation activities

Four **newsletters** have been produced during the project. The newsletters have been sent by e-mail to an address list of ca. 1,200 persons. Furthermore, glossy prints of the newsletter were handed out at meetings and congresses. The newsletters can be found in the Annex 29-Annex 32.

A **brochure** has been produced mentioning backgrounds, objectives, the workplan and the consortium (Annex 33). The brochure has been distributed at meetings and congresses.

4.7.7 Conclusions

Throughout the project, the objectives of the project and the results have actively been disseminated to a wide audience by means of a web-site, brochure, 4 newsletters, training, a workshop, a film, and by scientific publications in peer viewed journals and platform presentations and posters at conferences. This has generated awareness in the scientific world of the existence of the project and its results. In many cases positive responses were obtained from colleagues and from policy makers. DG SANCO (dr. F. Verstraete) has played an active role in the dissemination and he is gratefully acknowledged for his support to the project.

Partners involved

The dissemination has been coordinated by RIVO. RIKILT has assisted with the preparation of the film and with the CALUX training. Furthermore, various partners have actively disseminated their results by scientific publications in peer viewed journals and by platform presentations and posters at conferences.

External contractor Frisse Wind was responsible for the design of the logo and the web-site (which they also have built and implemented).

Milestones and deliverables

The following milestones have been finalised:

- M14 Video/DVD completed
- M15 Installation of web-site
- M17 Organisation of training course
- M19 Submission of scientific publications

The following deliverables have been delivered:

- D12 Video/DVD
- D13 Trainings course
- D14 Workshop
- D15a-d 4 newsletters

D16 Scientific publications

4.8 Work package 8: Coordination

The management of the project is discussed in chapter 5 Management and coordination aspects.

4.8.1 Task 33. Technological Implementation Plan

A draft Technological Implementation Plan (TIP) has been prepared prior to the mid-term meeting, which has been discussed at the dissemination workshop by dr. G. Vekenis (6 October 2003). Based on that meeting and the discussions, dr. Vekenis has written a DIFFERENCE expertise report that can be found in Annex 34.

The Technological Implementation Plan (TIP) can be found in Annex 34 and Annex 35. The implementation of the methods developed and validated will take place through protocols that have been produced within WP-5 in collaboration with technical committee TC/275 of CEN. The acceptance of use of the new methods in food control laboratories is enhanced through the contact with dr. F. Verstraete (DG Health and consumer protection). It is expected that, within future EU guidelines on analysis of dioxins and dl-PCBs, criteria will be laid down for acceptance of data produced by the new methods.

Furthermore, the implementation of the methods is facilitated by the dissemination of the results to a broad scientific community (WP-7).

Concerning the CRMs contacts have been established with JRC-IRMM (Geel, Belgium) for discussion of the production of CRMs for food and feed. At 16 June 2004, dr. H. Emons and dr. F. Ulberth were visited at IRMM. In these discussions, it became clear that the budgets for production of CRMs is very limited and that new materials for dioxins, dl-PCBs and ndl-PCBs are currently not included in the IRMM priorities. It is therefore expected that the materials will not become available in the next 5 years. This will negatively influence the implementation of EU strategy on monitoring of dioxins and (dl) PCBs in food and feed.

4.8.2 Task 34. Final report

No further details

4.8.3 Task 35. Management

The management and the partners involved is discussed in more detail in chapter 8.

Milestones and deliverables

The following deliverables and milestones have been met:

	Mid-term assessment report
M13	TIP completed
MT1-MT6	Progress meetings held

5. List of deliverables

Table 12 shows the deliverables and timetable for the different work packages as provided in the original technical annex, and the actual deliverables.

Table 12: Overview deliverables

Overview of Deliverables originally planned and actual work				
Delivery no.	DOW Deadline	Actual delivery date	Original delivery	Actual work performed
D15a	28/02/2002	12/04/2003	Newsletter 1	Has been written, see Annex 29
D8	30/04/2002	26/11/2002	Validation protocol	Has been prepared, see Annex 5.
D1	31/07/2002	31/03/2003	5 + 8 test materials, 6 sets of test solutions	The materials have been prepared and used within WP-3 and WP-4. Details on the materials produced can be found in Annex 6 and Annex 16.
D2	30/10/2002	22/05/2003	Report on feasibility of material preparation	The materials have been produced. Details on the production has been discussed in this report.
D15b	31/01/2003	19/12/2003	Newsletter 2	Has been written, see Annex 30
D7	31/01/2005		Report on extraction and clean-up methods	Has been written as a part of the progress reports and this final report
D4	31-7-2004 (rnd 3)	23-12-2003 (rnd 1 and 2) 21-03-2005 (rnd 3)	Report on screening method performance	One report on round 1 and 2 has been prepared and one report on round 3 has been prepared, see Annex 6 and Annex 16
D5	31/07/2003	08/10/2003	Protocols for interlaboratory studies	Protocols have been prepared and discussed at the workshop (see D14). They can be found as annexes in the report on feasibility of certification, see Annex 4.
	30/09/2003	23/12/2003	Mid-term assessment report	The assessment has taken place and the report has been written, see Annex 43.
D12	31/01/2005	15/01/2005	Instruction Video/DVD	A CD containing a promotional film has been produced. See Annex 28.
D15c	31/01/2004	07/07/2003	Newsletter 3	Has been written, see Annex 31.
D3	31-7-2004 (hom), 31-1-2005 (stab)	23-03-2005	Report on homogeneity and stability study	All experiments have been carried out and the results have been compiled in a report, see Annex 8.
D10	31/01/2005	24-09-2003 (draft TIP)	TIP	Has been prepared, see Annex 35.
D9	31/01/2005	21-03-2005 and 05-04-2005	Report on standardisation methods	Contacts have been established with CEN and currently a proposal for standardization is being prepared for discussion at CEN TC/275, see Annex 24
D14	31/10/2004	13 January 2005	Workshop	The workshop has taken place and ca. 70 persons attended the meeting. The agenda can be found in Annex 25 .
D13	13 and 14-01-2005	27/28-01-2005	Training course	Has taken place for CALUX and GCxGC. Due to organizational problems, the GC-LRMS/MS course could not (yet) take place.
D6	31/01/2005	28-04-2005	Report on feasibility of certification	Has been written, see Annex 4.
D16	31/01/2005	Various	Scientific publications	Various scientific publications have been written, see paragraph 4.7.1. and the annexes of this report
D15d	31/01/2005		Newsletter 4	Has been written, see Annex 32
Overview of Deliverables originally planned and actual work				

Delivery no.	DOW Deadline	Actual delivery date	Original delivery	Actual work performed
D15a	28/02/2002	12/04/2003	Newsletter 1	Has been written, see Annex 29
D8	30/04/2002	26/11/2002	Validation protocol	Has been prepared, see Annex 5.
D1	31/07/2002	31/03/2003	5 + 8 test materials, 6 sets of test solutions	The materials have been prepared and used within WP-3 and WP-4. Details on the materials produced can be found in Annex 6 and Annex 16.

6. Comparison of initially planned activities and work actually accomplished

An overview of the milestones planned and work actually accomplished is presented in Table 13.

Overview of milestones originally planned and actual work				
Mile stone no.	Actual milestone date	DOW deadline	Original decision criteria for assessment (Techn. annex)	Brief description of milestone objective (original/description t echnical annex)
M5	15/02/2002	31/03/2002	Start of method development	Method development has started
M10	15/02/2002	31/03/2002	Start of extraction/clean-up study	Study has been started
M15	01/04/2002	31/03/2002	Installation of website	The web-site has been developed and will be maintained after the project
M1	15/03/2002	30/04/2002	List of selected materials	Part of minutes kick-off meeting, see Annex 1.
M2	31/03/2003	31/07/2002	Materials canned and sterilised/freeze-dried/ampouled	Work has been performed and finalized, see this report (WP-1 materials) and Annex 6, Annex 7 and Annex 16.
M3	23-03-2005	31/03/2004	Homogeneity study completed	Work has been performed and a final report has been written, see Annex 8.
M11	31-10-2004	30/04/2003	Study on extraction/clean-up completed	The work has been finalized and the report is integrated in this final report. Details can also be found in various scientific publications listed under WP-7 and in the annexes.
M6	01/04/2004 and 21-03-2005	31/07/2003	Methods developed and optimised	The methods have been developed and optimized, although further optimizations can improve e.g. CALUX and Ah-PCR techniques. The validation results can be found in Annex 6, Annex 7 and Annex 16.
M7	9 and 10-10-2003	31/07/2003	Start of interlaboratory study	Interlaboratory study has taken place.
M13	30-04-2005	31/10/2003	TIP completed	TIP completed, see Annex 35.
M8	15 and 16 April 2004	31/01/2004	End of first interlaboratory study	The first interlaboratory study has been performed and reported.
M14	15-01-2005	31/01/2004	Video/DVD completed	The CD containing the film 'A world of DIFFERENCE' has been produced, see Annex 28.
M4	31-01-2005	31/03/2004	Stability study completed	The work has been performed and reported, see Annex 8.
M12	30-04-2005	31/07/2004	Standardisation of methods completed	The standardization is still ongoing through contacts with CEN. This will continue after the finalization of the project.
M9	16/17-11-2004	31/10/2004	Interlaboratory study completed	The first interlaboratory study has been performed and reported.
M16	13-01-2005	31/10/2004	Organisation of workshop	The workshop has taken place and ca. 70 persons attended the meeting. The agenda can be found in Annex 25.
M17	27/28-01-2005	30/11/2004	Organisation of training course	Has taken place for CALUX and GCxGC. Due to organizational problems, the GC-LRMS/MS course could not (yet) take place.
M19	Various dates	31/01/2005	Submission of scientific papers	Various scientific publications have been written, see paragraph 4.7.1. and the annexes of this report

7. Management and co-ordination aspects

The overall coordination of the project was carried out by RIVO (prof. dr. J. de Boer and mr. S. van Leeuwen), whereas the coordination within the work packages was left to the WP-leaders. The delivery dates of some of the deliverables mentioned in the DoW was adjusted after discussion with the partners and the scientific officer (SO) (see Annex 1). For example, the design of the validation protocol of WP-3 was changed from 4 rounds (in the DoW) to 3 rounds to allow the partners to invest more time in method optimisation between the rounds. This has improved the quality of the work carried out in this WP. The reporting of results was delayed in some cases compared to the dates mentioned in the DoW (e.g. mid term assessment report), but this has not negatively influenced the progress of the project.

The project has successfully carried out all the deliverables mentioned in the DoW and Annex 2. The only exception to this is the optimisation and validation of the Ah-PCR technique, which was considerably delayed because the responsible laboratory and scientists have been moved from Ispra (Italy) to JRC-IRMM, Geel, Belgium. Therefore, the Ah-PCR technique is not fully validated at this stage.

Progress and other meetings

Besides the kick-off meeting, five progress meetings took place (for dates and venues see Annex 1). The mid-term meeting was combined with the 3rd progress meeting and the workshop of WP-4 for instruction of the participants. No final meeting took place as the finalising issues of the project were discussed at the 5th progress meeting, at the workshop (13 January 2005) and through e-mail communication with the partners. Minutes of the kick-off, progress and mid term meetings can be found in Annex 1, Annex 36 to Annex 41.

Two progress reports have been delivered. The 1st progress report was prepared containing the results of year 1 (Annex 3) and the 2nd progress report contained the results of the 2nd year of the project. (Annex 42).

Meetings with the expert panel

An external expert panel, consisting of dr. F. Verstraete, dr. R. Malisch, dr. B. van Bavel and dr. P. Behnisch has advised two times the project group. The first time was at the 2nd progress meeting (Brussels, Belgium, February 2003) and the second time was at the 4th progress meeting (Antwerp, Belgium, April 2004). Generally, the expert panel was very positive about the progress of the project and the achievements being made. Also, they have made recommendations to the project consortium, which can be found in the minutes of the meetings (see Annex 44 and Annex 45). The project group has paid attention to these remarks in the course of the project.

Finally, the panel has attended the Workshop of 13 January 2005, Brussels, Belgium.

8. Results and Conclusions

The conclusions on the technical achievements have been discussed in chapter 4 at the end of every work package. Furthermore, general, overall conclusions have been drawn in the executive summary. For that reason, no further conclusions are drawn here.

9. Acknowledgements

We would like to thank the members of the external expert team (dr. F. Verstraete, dr. R. Malisch, dr. B. van Bavel and dr. P. Behnisch) for their advice and fruitful discussions. Furthermore, prof. U.A.Th. Brinkman and ir. L.G.M.Th. Tuinstra are acknowledged for their contributions to the project. Finally, prof. dr. G. Becher is acknowledged for his advice throughout the course of the project.

10. References

- ISO Guide 35, I. G. (2001). Certification of reference materials - general and statistical principles, 3rd ed., draft 2. Geneva, International Organization for Standardization.
- Ahlström, L.-H., S. Sporning, et al. (2005). "Microwave-Assisted Extraction of Seven Selected Polychlorinated Biphenyls from Feed Samples." *Chromatographia*, submitted.
- Ahlström, L.-H., R. Westbom, et al. (2005). "Utilization of a supercritical fluid extractor coupled on-line to a prolonged solid phase trap for simultaneous extraction and separation of PCBs and lipids from a model fat sample and meat reference material." *Chromatographia* Submitted.
- Aidos, I. (2002). Production of High-Quality Fish Oil from Herring Byproducts. Dept. Agrotechnology and Food Sciences. Wageningen, Wageningen University: 203.

- Aidos, I., A. van de Padt, et al. (2001). "Upgrading of Maatjes Herring Byproducts: production of crude fish oil." *Journal of agriculture and food chemistry* 49(8): 3697-3704.
- de Boer, J., J. van der Meer, et al. (1994). "Determination of chlorobiphenyls in cleaned-up seal blubber and marine sediment extracts: interlaboratory study." *Journal of AOAC International* 77(6): 1411-1422.
- EC (2001). "Council regulation (EC) No 2375/2001 of 29 November 2001 amending Commission Regulation No 466/2001 setting maximum levels for certain contaminants in foodstuffs." *Official Journal of the European Communities*(L321/1).
- EC (2002). "BCR information - Guidelines for feasibility studies on certified reference materials." Directorate-General for research EUR 20574 EN.
- EC (2002). "Commission Directive 2002/69/EC laying down the sampling methods and the methods of analysis for the official control of dioxins and the determination of dioxin-like PCBs in foodstuffs." *Official Journal of the European Communities*(L209/5).
- EC (2002). "Commission Directive 2002/70/EC of 26 July 2002 establishing requirements for the determination of levels of dioxins and dioxin-like PCBs in feedingstuffs." *Official Journal of the European Communities*(L209/15).
- EC (2002). "Council Directive 2001/102/EC of 27 November 2002 amending Directive 1999/29/EC on undesirable substances and products in animal nutrition." *Official Journal of the European Communities*(L6/45).
- Focant, J. F., E. J. Reiner, et al. (2004). "Measurement of PCDDs, PCDFs, and non-ortho-PCBs by comprehensive two-dimensional gas chromatography-isotope dilution time-of-flight mass spectrometry (GC x GC-IDTOFMS)." *Talanta* 63(5): 1231-1240.
- Korytar, P., P. E. G. Leonards, et al. (2002). "High-resolution separation of polychlorinated biphenyls by comprehensive two-dimensional gas chromatography." *Journal Of Chromatography A*. Jun 958(1-2): 203-218.
- Lamberty, A., H. Schimmel, et al. (1998). "The study of the stability of reference materials by isochronous measurements." *Fresenius journal of analytical chemistry* 360: 359-361.
- Nording, M., S. Sparring, et al. (2005). "Monitoring dioxins in food and feedstuffs using accelerated solvent extraction with a novel integrated carbon fractionation cell in combination with a CAFLUX bioassay." *Analytical and Bioanalytical Chemistry* 381(7): 1472-1475.
- Sparring, S. and E. Bjorklund "Selective pressurized liquid extraction of polychlorinated biphenyls from fat-containing food and feed samples - effects of high lipid amounts and lipid type on fat retention in large volume cells." Manuscript.
- Sparring, S. and E. Bjorklund (2004). "Selective pressurized liquid extraction of polychlorinated biphenyls from fat-containing food and feed samples - Influence of cell dimensions, solvent type, temperature and flush volume." *Journal of Chromatography A* 1040(2): 155-161.
- Sparring, S. and E. Björklund (Manuscript). "Supercritical fluid extraction of PCBs and fat from fish matrices with on-line separation on a long solid phase trap."
- Traag, W. A., K. Kan, et al. (2003). "Carry-over of dioxins and PCBs from feed to eggs at low contamination levels." *Organohalogen Compounds* 61: 381-384.
- van Bavel, B., M. Jaremo, et al. (1996). "Development of a Solid Phase Carbon Trap for Simultaneous Determination of PCDDs, PCDFs, PCBs, and Pesticides in Environmental Samples Using SFE-LC." *Analytical chemistry* 68: 1279-1283.
- van Leeuwen, S. P. J., J. de Boer, et al. (2002). The certification of the contents (mass fractions) of polychlorobiphenyls IUPAC No 28, 52, 101, 118, 128, 138, 149, 153, 156, 170 and 180 in canned fresh herring (*Clupea harengus*) - BCR 718. Brussels, European Commission.
- van Leeuwen, S. P. J., J. de Boer, et al. (2002). The certification of the contents (mass fractions) of polychlorobiphenyls IUPAC No 77, 81, 126 and 169 in fresh canned fresh chub (*Squalius cephalus*) - BCR 719. Brussels, European Commission.
- Van Loco, J., S. P. J. Van Leeuwen, et al. (2004). "The international validation of bio- and chemical-analytical screening methods for dioxins and dioxin-like PCBs: the DIFFERENCE project rounds 1 and 2." *Talanta* 63(5): 1169-1182.
- von Holst, C., A. Müller, et al. (2005). "Optimisation of pressurized liquid extraction for the determination of seven selected polychlorinated biphenyls in feed samples." *Chromatographia* 61: 391-396.

Annexes overview

- Annex 1. WP-8 Minutes of kick-off meeting
- Annex 2. WP-8 Overview of milestones and deliverables of the project
- Annex 3. WP-8 Progress report year 1
- Annex 4. WP-4 Feasibility of certification of new reference materials for dioxins and PCBs in food and feed - Final report DIFFERENCE WP4
- Annex 5. WP-6 protocol: Validation and standardization of the bioanalytical and chemical analytical screening methods
- Annex 6. WP-3 Validation and standardisation of the bioanalytical and chemical analytical screening methods, Final report WP-3 round 1 and 2, J. Van Loco, S. Van Leeuwen, P. Roos and H. Beernaert
- Annex 7. WP-7 Van Loco, J., et al., The international validation of bio- and chemical- analytical screening methods for dioxins and dioxin-like PCBs: the DIFFERENCE project rounds 1 and 2. *Talanta*, 2004. 63(5): p. 1169-1182.
- Annex 8. WP-2 Final report of WP-2, Homogeneity and stability studies
- Annex 9. WP-3 Minutes of CALUX optimisation meeting at IPH, Brussels 28 March 2003
- Annex 10. WP-7 Sophie Carboneille, Joris Van Loco, Ilse Van Overmeire, Isabelle Windal, Nathalie Van Wouwe, Stefan Van Leeuwen, Leo Goeyens, Importance of REP values when comparing the CALUX bioassay results with chemoanalyses results. Example with spiked vegetable oils. *Talanta* 63: 1255-1259, 2004.
- Annex 11. WP-7 Korytár P, Leonard, P.E.G., de Boer, J. and Brinkman U A Th. *Journal of Chromatography A*, 958:203-218, 2002
- Annex 12. WP-7 Kristenson E.M, Korytár P, Danielsson C, Kallio M, Brandt M, Mäkelä J, Vreuls R, Beens J, Brinkman U A Th. *Journal of Chromatography A*, 1019:65-77, 2003
- Annex 13. WP-7 Danielsson C., Wiberg K., Korytár P., de Boer J. and Haglund P. Trace analysis of PCDD/Fs and WHO PCBs in food and feed using comprehensive two-dimensional gas chromatography (GCxGC). *Organoh. Comp.* 60: 395-398, 2003
- Annex 14. WP-7 Korytar *et al.*, GCxGC method development for the analysis of seventeen 2,3,7,8-substituted dioxins, furans and twelve dioxin-like PCBs *Organoh. Comp.* 60: 355-358, 2003.
- Annex 15. WP-7 Abalos, M. *et al.*, Ion trap MS/MS vs. HRMS for the analysis of PCDD/Fs and dioxin-like-PCBs in food samples, *Organoh. Comp.* 60: 452-455, 2003.
- Annex 16. WP-3 The international validation of Chemical and Biological Screening Methods for dioxins and dl-PCB's: The DIFFERENCE Project round 3, J. Van Loco, S.P.J Van Leeuwen and H. Beernaert
- Annex 17. WP-7 van Leeuwen S.P.J., Van Loco J, de Boer J, *Organohalogen compounds* 60 (2003)
- Annex 18. WP-7 Van Loco J, van Leeuwen S.P.J., Carboneille, S., Goeyens, L. Beernaert, H., The International validation of chemical and biological screening methods for dioxins and dl-PCBs: the DIFFERENCE project round 3, *Organohalogen Compounds*, Vol 66
- Annex 19. WP-7 Ahlström, L.-H., S. Sparring, C. von Holst, E. Björklund, Microwave-Assisted Extraction of Seven Selected Polychlorinated Biphenyls from Feed Samples, *Chromatographia*, submitted
- Annex 20. WP-7 von Holst, C., A. Müller, et al. (2005). "Optimisation of pressurized liquid extraction for the determination of seven selected polychlorinated biphenyls in feed samples." *Chromatographia* 61: 391-396.
- Annex 21. WP-7 Sparring, S. and E. Bjorklund (2004). "Selective pressurized liquid extraction of polychlorinated biphenyls from fat-containing food and feed samples - Influence of cell dimensions, solvent type, temperature and flush volume." *Journal of Chromatography A* 1040(2): 155-161.
- Annex 22. WP-7 Nording, M., S. Sparring, et al. (2005). "Monitoring dioxins in food and feedstuffs using accelerated solvent extraction with a novel integrated carbon fractionation cell in combination with a CAFLUX bioassay." *Analytical and Bioanalytical Chemistry* 381(7): 1472-1475.
- Annex 23. WP-6. Method details request form for the determination of dioxins and dl-PCBs in food and feed
- Annex 24. WP-6 Proposal for standardisation protocol for discussion with CEN technical committee TC/275.

-
- Annex 25. WP-7 Workshop Announcement - Alternative Techniques for the Analysis of Dioxins and Dioxin-like PCBs in Food and Feed, 13 January 2005, Hotel Carrefour de l'Europe, Brussels, Belgium
 - Annex 26. WP-7 Final film script "A world of DIFFERENCE"
 - Annex 27. WP-7 Final production schedule "A world of DIFFERENCE"
 - Annex 28. WP-7 CD film "A world of DIFFERENCE"
 - Annex 29. WP-7 Newsletter 1
 - Annex 30. WP-7 Newsletter 2
 - Annex 31. WP-7 Newsletter 3
 - Annex 32. WP-7 Newsletter 4
 - Annex 33. WP-7 Brochure of the DIFFERENCE project
 - Annex 34. WP-8 DIFFERENCE expertise report
 - Annex 35. WP-8 Technological Implementation Plan
 - Annex 36. WP-8 Minutes of 1st progress meeting
 - Annex 37. WP-8 Minutes of 2nd progress meeting
 - Annex 38. WP-8 Minutes of 3rd progress meeting
 - Annex 39. WP-8 Minutes of 4th progress meeting
 - Annex 40. WP-8 Minutes of 5th progress meeting
 - Annex 41. WP-8 Minutes of mid-term meeting
 - Annex 42. WP-8 Progress report year 2.
 - Annex 43. WP-8 Mid-term report
 - Annex 44. WP-8 Minutes first external expert panel meeting
 - Annex 45. WP-8 Minutes second external expert panel meeting