

Farmers, seeds and varieties

Supporting informal seed supply in Ethiopia

The following organizations are partners in the compilation of this publication:



The Ethiopian Seed Enterprise (ESE) has the mission to deliver high quality seeds of cereals, fruits, vegetables, forages, spices and other crops to farmers and other end users on commercial basis, by multiplying and processing seeds from breeder seeds acquired from the national research centers and import from abroad, helping to enhance the production and productivity of the agricultural sector in Ethiopia. P.O. Box 2453, Addis Ababa, Ethiopia.



The International Centre for Agricultural Research in Dry Areas (ICARDA) is part of the Consultative Group on International Agricultural Research (CGIAR). ICARDA's research provides global benefits of poverty alleviation through productivity improvements integrated with sustainable natural-resource management practices. P.O. Box 5466, Aleppo, Syrian Arab Republic; www.icarda.cgiar.org



Wageningen International of Wageningen University and Research Centre aims through its Capacity Development and Institutional Change Programme to empower individuals and organizations with the capacities for learning, innovation and institutional change to create a sustainable future. P.O. Box 88, 6700 AB Wageningen, The Netherlands; www.cdic.wur.nl

The publication is financed by:



The Netherlands Organization for International Cooperation in Higher Education (Nuffic) through the Netherlands Fellowship Programmes (Project: NFP/ETH/05/32). Nuffic strives to be the intermediary between the education community of the Netherlands and the international community. P.O. Box 29777, 2502 LT The Hague, The Netherlands; www.nuffic.nl

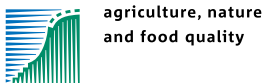

The Dutch Ministry of Agriculture, Nature and Food Quality (LNV) through the Policy Support Cluster International Cooperation. P.O. Box 20401, 2500 EK The Hague, The Netherlands; www.minlnv.nl

Edited by Marja H. Thijssen, Zewdie Bishaw, Abdurahman Beshir
and Walter S. de Boef

Farmers, seeds and varieties

Supporting informal seed supply in Ethiopia

Wageningen International, 2008

Citation:

Thijssen, M.H., Z. Bishaw, A. Beshir and W.S. de Boef, 2008 (Eds.). Farmers, seeds and varieties: supporting informal seed supply in Ethiopia. Wageningen, Wageningen International. 348 p.

Published by:

Wageningen International, Programme for Capacity Development and Institutional Change, Wageningen University and Research Centre
Address: P.O. Box 88, 6700 AA Wageningen, The Netherlands
Internet: www.cdic.wur.nl

Readers are encouraged to quote, reproduce, disseminate and translate materials from this book. Due acknowledgment, with full reference to the article's authors and book publisher, is requested.

ISBN: 978-90-8585-215-5

English editor: Clare McGregor, <http://thinkinenglish.eu>

Cover design: Martin Jansen, Wageningen UR, Communication Services

Cover photos: Sean Gladwell, Marja H. Thijssen, Scott Black and Juha-Pekka Kervinen

Printing: Tailormade, Buren

The views and opinions expressed in the papers are those of the authors and do not necessarily reflect the views of the editors and their organizations.

Contents

Preface	9
<i>Getahun Alemu</i>	
Acknowledgements	11
Editors	13
Contributing authors	15
Introduction	21
1 Context and concepts	
1.1 The status of the Ethiopian seed industry	23
<i>Zewdie Bishaw, Yonas Sablu and Belay Simane</i>	
1.2 The farmer-based seed production and marketing scheme: lessons learnt	33
<i>Yonas Sablu, Belay Simane and Zewdie Bishaw</i>	
1.3 A system perspective for linking farmers and professionals supporting farmers' practices in seed supply	47
<i>Walter S. de Boef and Zewdie Bishaw</i>	
1.4 Participatory and learning-oriented approaches	54
<i>Walter S. de Boef, Marja H. Thijssen, Cecile Kusters and Karèn S. Verboosel</i>	
1.5 Seed professionals starting to approach informal seed supply through a learning and action oriented training programme	63
<i>Marja H. Thijssen, Abdurahman Beshir, Zewdie Bishaw, Anthony J.G. van Gastel, and Walter S. de Boef</i>	
1.6 Robust seed systems: integrating a genetic resource conservation and sustainable livelihood perspective in strategies supporting informal seed supply	73
<i>Johannes M.M. Engels, Jean Marie Byakweli Vianney, Hannes Dempewolf and Walter S. de Boef</i>	
2 Supporting informal seed supply	
2.1 Supporting farmers in maintaining and selecting seeds of local varieties	87
<i>Conny Almekinders and Niels P. Louwaars</i>	
2.2 Supporting farmers' practices in seed processing and storage	96
<i>Niels P. Louwaars and Conny Almekinders</i>	
2.3 Community seed banks: experiences from Tigray in Ethiopia	100
<i>Trygve Berg and Fetien Abay</i>	

2.4	Community seed banks: experiences from Nepal <i>Pitambar Shrestha, Bhuvon Sthapit, Pratap Shrestha, Madhusudhan Upadhyay and Mahanaryan Yadav</i>	103
2.5	Seed relief intervention and resilience of local seed systems under stress: the case of Humbo woreda in Southern Ethiopia <i>Asrat Asfaw, Anbes Tenaye and Endrias Geta</i>	109
2.6	Reaching farmers in remote areas with improved bean varieties: lessons from Uganda <i>Losira Nasirumbi, Jean Claude Rubyogo, Michael Ugen, Annet Namayanja and Gabriel Luyima</i>	113
2.7	Smallholder farmers' participation in legume seed supply in Kenya <i>Mary W.K. Mburu, Richard B. Jones, Said N. Silim, Fred Ogana, George A. Odingo and Johnson W. Irungu</i>	119
3	Conservation and use of farmers' varieties	
3.1	Agrobiodiversity, conservation strategies and informal seed supply <i>Walter S. de Boef</i>	125
3.2	Informal seed systems and on-farm conservation of local varieties <i>Bhuvon Sthapit, Ram Rana, Pashupati Chaudhary, Bimal Baniya and Pratap Shrestha</i>	133
3.3	Genetic diversity and informal seed systems in Ethiopia <i>Girma Balcha and Tesema Tanto</i>	137
3.4	Conservation of genetic diversity and supporting informal seed supply in Ethiopia <i>Girma Balcha and Tesema Tanto</i>	141
3.5	Role of community gene/seedbanks in the conservation and use of crop genetic resources in Ethiopia <i>Johannes M.M. Engels, Severin Polreich and M. Ehsan Dulloo</i>	149
3.6	Mobilizing and empowering communities in biodiversity management <i>Bhuvon Sthapit, Pratap Shrestha, Abishkar Subedi, Pitambar Shrestha, Madhusudan Upadhyay and Pablo Eyzaguirre</i>	160
3.7	Practices supporting community management of farmers' varieties <i>Bhuvon Sthapit, Abishkar Subedi, Pitambar Shrestha, Pashupati Chaudhary, Pratap Shrestha and Madhusudan Upadhyay</i>	166
3.8	On-farm conservation of farmer varieties: selected experiences in Asia <i>Arma Bertuso, Hans Smolders and Bert Visser</i>	171

4	Participatory crop improvement and supporting informal seed supply	
4.1	Participatory crop improvement and informal seed supply: general introduction <i>Walter S. de Boef and Juliana Bernardi Ogliari</i>	177
4.2	Opportunities for participatory crop improvement and supporting informal seed supply in Oromia region, Ethiopia <i>Adugna Wakjira, Gemechu Keneni, Musa Jarso and Bulcha Weyessa</i>	185
4.3	Participatory varietal evaluation and breeding of the common bean in the Southern region of Ethiopia <i>Asrat Asfaw</i>	192
4.4	Participatory varietal selection of barley in the highlands of Tigray in Northern Ethiopia <i>Fetien Abay and Asmund Bjørnstad</i>	198
4.5	Working with farmer research committees in participatory bean breeding in Honduras <i>Sally Humphries, Omar Gallardo, José Jiménez, Fredy Sierra and the Association of CLALS of Yorito, Victoria and Sulaco</i>	207
4.6	Farmer field schools supporting farmer-led participatory plant breeding: some Asian experiences <i>Hans Smolders, Arma Bertuso and Bert Visser</i>	216
5	Small-scale and community enterprises: increasing local availability of seed and enhancing farmers' access to it	
5.1	Supporting the development of small to medium-scale seed enterprises in sub-Saharan Africa <i>John F. MacRobert</i>	225
5.2	Business principles for the establishment of a viable small-scale seed enterprise <i>Anthony J.G. van Gastel, Zewdie Bishaw and Bill R. Gregg</i>	231
5.3	Village-based seed enterprises in Afghanistan <i>Zewdie Bishaw, Anthony J.G. van Gastel, Abdoul Aziz Niane and Koffi Amegbeto</i>	240
5.4	Farmer seed enterprises in Uganda <i>Soniia David</i>	245
5.5	Small-scale farmers' rice seed enterprises in Bangladesh <i>Heleen Bos, Conny Almekinders and Kazji Borhan Amin Raj</i>	255
5.6	Community-based seed production groups in Chitwan, Nepal <i>Krishna P. Devkota, Mahendra P. Tripathi, Krishna D. Joshi, Pratap K. Shrestha and John R. Witcombe</i>	263

6	Initial experiences supporting the establishment of community-based and small-scale seed enterprises in Ethiopia	271
6.1	Cooperative community-based seed enterprises in Hararghe, Ethiopia: strategy and first lessons learnt <i>Osman E. Ibrahim</i>	272
6.2	Avola Goshiye Community-based Seed Enterprise in Yilmana Densa woreda, Amhara region <i>Amelework Beyene, Alem Yalew, Abebew Assefa and Yimam Tessema</i>	282
6.3	Erer Union Seed Producers and Marketing Cooperative, Gimbichu District, Oromia region <i>Shemsu Baissa, Imiru Mijana, Eshetu Sisay, Demissie Mitiku, Ali Adem, Tadesse Wube and Zenebe W/Silase</i>	287
6.4	Wamura-Sako Small-scale Farmers Seed Producers' Group in Dendi woreda, central west Oromia region <i>Messele Shimels, Assefa Senbeta, Hagos Gidey, Goshime Tekle, Fikere Mulugeta, Adugna Kefeni and Girma Chemedo</i>	292
6.5	Wamole farmers' cooperative for maize seed production in Boricha woreda, SNNPR <i>Tesfaye Tadesse, Tefera Zeray, Mata Gedebo, Abebe Tilahu and Solomon Benor</i>	297
6.6	Felegeweni and Mekan community-based seed enterprises in Atsibi Womberta and Endamehoni district, Tigray region <i>Tadesse Teweldebrhan, Beyene Dimitsu, Muez Teare and Woldehanariat Assefa</i>	301
7	Creating enabling policy frameworks for supporting informal seed supply	
7.1	Seed policies: enabling support to informal seed systems <i>Niels P. Louwaars and Johannes M.M. Engels</i>	307
7.2	Seed policies and regulations and informal seed supply in Ethiopia <i>Belay Simane</i>	312
7.3	International dimensions of plant variety protection and informal seed supply in Ethiopia <i>Robert J. Lewis-Lettington</i>	316
7.4	Biodiversity and genetic resource access laws and informal seed supply with specific reference to Ethiopia <i>Robert J. Lewis-Lettington</i>	323
7.5	Opportunities for policy development supporting informal seed supply of local crops and varieties in Ethiopia <i>Walter S. de Boef and Anthony J.G. van Gastel</i>	332
	References	337

Preface

Agriculture is the mainstay of the Ethiopian economy, substantially contributing to rural employment, foreign export markets, raw materials for industry, and the GDP. However, the agricultural sector is largely characterized by small-scale subsistence farming and low productivity. This low productivity is detrimental to the economic development and growth of the country. The Government of Ethiopia therefore puts great emphasis on increasing the production and productivity of small-scale farmers.

Low productivity is partly due to limited use of improved varieties and associated technologies, so the availability and use of improved varieties and seeds play an important role in this endeavor. The annual potential seed requirement is estimated to be more than 150,000 tons, but the formal sector supply does not exceed 20,000 tons, of which 80-90% comes from the Ethiopian Seed Enterprise (ESE). The ESE, under the supervision of the Ministry of Agriculture and Rural Development, is expected to support the rural development strategy, and the improvement of the seed supply to smallholder farmers in particular, by filling the gap for economically important crop varieties.

However, due to various limitations, including Ethiopia's immense diversity in agro-ecology, the ESE has fallen far short of satisfying the seed requirements of the nation, and alternative seed delivery systems have been designed to tackle the shortfall through farmer-based seed production. Over the last three years, the ESE has taken over responsibility for the farmer-based seed production and marketing scheme. So far the scheme has accounted for more than 30% of the ESE's total seed production, and it is expected to expand significantly in the coming years. According to the five year plan, more emphasis will be given to basic seed production, so as to support the regional states and public and private sector companies in facilitating certified seed production. Priority will be given to crops that are important for food self sufficiency.

The farmer-based seed production scheme is the cornerstone of our efforts to fill the gap between the demand for seed and the supply. This huge task also requires the participation of the major stakeholders from both the federal and the regional states. Cognizant of this, the ESE and its partners, Wageningen International, The Netherlands and the International Center for Agricultural Research in the Dry Areas, Syria, developed and implemented a project entitled 'The improvement of farmer-based seed production scheme and revitalizing informal seed supply of local crops and varieties in Ethiopia'. The tailor-made training programme followed a multi-stakeholder process approach, engaging participants representing various stakeholders in a process of learning and action research. The focus was on the use of participatory approaches in the improvement of farmer seed production to revitalize informal seed supply, and the establishment of sustainable small-scale seed enterprises.

The one-year programme went through several stages, starting with the training of a core group of participants from various federal and regional institutions (acquiring knowledge and integrating theory with practice). This was followed by a diagnosis of regional seed systems and the design of alternative schemes (translating

knowledge into action), the presentation and discussion of these with stakeholders in regional state workshops, and the implementation of the first farmer-based seed activities. In addition, a national seed policy workshop addressed the rationalization of policy and regulatory frameworks. The programme ended with a regional experience-sharing workshop in which participants presented experiences of farmer-based approaches from Ethiopia, Africa and Asia, related to genetic resources conservation, participatory crop improvement and local seed supply.

This book blends these very diverse experiences from IARCs, NARS and NGOs, and presents them in a concise format. We hope it will be useful for policy makers, researchers, seed sector professionals, development agents and NGOs working to develop farmer-based seed production.

I would like to thank Nuffic and the Dutch Ministry of Agriculture, Nature and Food Quality for their financial support, and the contributors and the editorial team for bringing the project to a successful conclusion.

Getahun Alemu
General Manager ESE, Addis Ababa

Acknowledgements

This book has been a collaborative effort and we would like to thank all the people and organizations that contributed to it. First of all, we would like to thank all the authors for their high quality contributions to this book. We believe that this collection of papers, presenting a diversity of concepts, perspectives, strategies and approaches, offers a highly valuable resource for professionals working to support local seed supply in Ethiopia and beyond.

We also specifically wish to thank the participants of the tailor-made training programme on the improvement of farmer-based seed production and revitalizing informal seed supply of local crops and varieties in Ethiopia, and their organizations who allowed them to participate in the intensive one-year programme, and supported them throughout. The openness of the participants to new strategies and approaches, to working closely together with new partners, their new professionalism in working with farmers, and their commitment made the training a success. The book reports on various aspects of the training, and presents their experiences.

We are very grateful to the team of knowledgeable resource persons and facilitators from Ethiopia and abroad that contributed their experiences to the training and their papers to the book. We thank the Ethiopian Seed Enterprise, the Ministry of Agriculture and Rural Development, the Institute of Biodiversity Conservation, the Southern Agricultural Research Institute, Mekele University, Addis Ababa University, the International Wheat and Maize Improvement Center, Bioversity International, and the Association for Strengthening Agricultural Research in Eastern and Central Africa for their inputs.

We gratefully acknowledge the ESE management, Ato Getahun Alemu, Ato Getachew Desta, and all other ESE staff who have supported the intensive training programme in all its activities.

We would like to thank Clare McGregor for the great job done on the English editing; Karèn Verhoosel for her assistance in the compilation of the book; Martin Jansen for the beautiful cover design.

We would like to thank the Netherlands Organization for International Cooperation in Higher Education (Nuffic) for financing the tailor-made training through the Netherlands Fellowship Programme, and the Dutch Ministry of Agriculture, Nature and Food Quality for sponsoring the publication of this book through the Policy Support Cluster International Cooperation.

And last but not least, we want to thank the farmers that have been involved in the training for their interest, their enthusiasm and their commitment to the pilot activities.

Wageningen, 10 April 2008

Marja H. Thijssen, Zewdie Bisban, Abdurahman Beshir and Walter S. de Boef

Editors

Marja Helen Thijssen was trained as a plant breeder and biotechnologist. She has been working with Wageningen International since 1997, in the area of agrobiodiversity conservation and management, crop improvement and seed sector development. Her interests are participatory and multi-stakeholder approaches in these areas. Her work in capacity building includes the design, coordination and implementation of training programmes in a range of projects around the world. Marja acted as a coordinator, trainer and facilitator in the training on farmer-based seed production and revitalizing informal seed supply of local crops and varieties in Ethiopia.

Zewdie Bishaw is a seed technologist by training. As head of the Seed Unit at ICARDA he is responsible for strengthening the national seed delivery systems in the ICARDA mandate regions. In his work he is particularly interested in seed policy and regulation, seed enterprise development, local/informal seed systems, seed security and human resource development. He worked at Awassa College of Agriculture and the Ethiopian Seed Corporation (now the Ethiopian Seed Enterprise) before joining ICARDA in Syria in 1989. Zewdie acted as a coordinator, facilitator and trainer in the Ethiopian training programme.

Abdurahman Beshir is a plant scientist by training and has been working in different positions at the Ethiopian Seed Enterprise since 1996, addressing plant protection, seed quality control, seed technology and crop improvement. He has a broad experience of farmer-based seed production in Ethiopia, and of training in this topic. His special interests are technology generation and dissemination, seed business development, and seed and food security related issues. Abdurahman was the national coordinator of the training programme in Ethiopia. He currently studies plant breeding/biotechnology at the University of the Free State in Bloemfontein, South Africa.

Walter Simon de Boef is visiting professor at the Federal University of Santa Catarina in Florianopolis, Brazil. He has a background in communication and innovation studies. His research and teaching activities address participatory approaches to plant genetic resources management, plant breeding and seed supply. He is also associated with Wageningen International as a consultant and trainer in projects around the world supporting community focused approaches in this field. Walter acted as trainer and facilitator in the Ethiopian training programme.

Contributing authors

- Abdoul Aziz Niane, Seed Production Manager, Seed Unit, International Centre for Agriculture in Dry Areas (ICARDA), Aleppo, Syria, a.niane@cgair.org
- Abdurahman Beshir, Breeder, Ethiopian Seed Enterprise (ESE), Addis Ababa, Ethiopia, abdurahmanb@gmail.com
- Abebe Tilahu, Seed Quality Control Center head, Bureau for Agriculture and Rural Development (BoARD), SNNPR, Ethiopia, abetibma@yahoo.com
- Abebew Assefa, Expert, Bureau of Agriculture and Rural Development (BoARD), Amhara, Ethiopia, bbwasefa@yahoo.com
- Abishkar Subedi, Programme officer, Local Initiatives for Biodiversity, Research and Development (LI-BIRD), Pokhara, Nepal, abishkar@libird.org/abishkar@hotmail.com
- Adugna Kefeni, Agronomist, Sasakawa Global 2000 (SG 2000), Ethiopia, tesg2000@ethionet.et
- Adugna Wakjira, Researcher, Holetta Research Center (HARC), Ethiopian Institute for Agricultural Research (EIAR), Addis Ababa, Ethiopia, adugnawg@yahoo.com
- Alem Yalew, Department head, Bureau of Agriculture and Rural Development (BoARD), Amhara, Ethiopia, alemyalew@yahoo.com
- Ali Adem, Seed production and crop protection head, Ethiopian Seed Enterprise (ESE), Addis Ababa, Ethiopia, aliademy@yahoo.com
- Amelework Beyene, Researcher, Amhara Regional Agricultural Research Institute (ARARI), Bahir Dar, Ethiopia, amele_g@yahoo.com
- Anbes Tenaye, Researcher, Southern Agricultural Research Institute (SARI), Awassa, Ethiopia, anbes2003@yahoo.com
- Annet Namayanja, Plant breeder, National Agricultural Research Organization (NARO)/ Uganda, National Banana Research Programme (UNBRP)/ National Crops Resources Research Institute (NaCRRI), Namulonge, Uganda, annetnama@yahoo.com
- Anthony J.G. van Gastel, Private consultant, Terherne, The Netherlands, tonyvangastel@gmail.com
- Arma Bertuso, Co-coordinator, Participatory Enhancement of Diversity of Genetic Resources in Asia (PEDIGREA), Laguna, Los Banos, The Philippines, armabertuso@yahoo.com
- Asmund Bjørnstad, Professor, Norwegian University of Life Sciences (NORAGRIC), Ås, Norway, asmund.bjornstad@umb.no
- Asrat Asfaw, Researcher, Southern Agricultural Research Institute (SARI), Awassa, Ethiopia, asratasfaw@yahoo.co.uk

Assefa Senbeta, Seed production and extension section head, Ethiopian Seed Enterprise (ESE), Wollega, Oromia, Ethiopia, assefaalito@yahoo.com

Association of CIALS Yorito, Victoria and Sulaco, Farmer-researchers and farmer-breeders, Yorito, Yoro, Honduras, asocialhondurena@yahoo.es

Belay Simane, Associate professor, Institute of Development Research, Addis Ababa University, Ethiopia, belaysimane@ethionet.et

Bert Visser, Director, Centre for Genetic Resources (CGN), Wageningen, The Netherlands, bert.visser@wur.nl

Beyene Dimitsu, Crop Research Director, Tigray Agricultural Research Institute (TARI), Mekele, Tigray, Ethiopia, demtsu@yahoo.com

Bhuwon Sthapit, Scientist In-situ crop conservation, Bioversity International, Pokhara, Nepal, b.sthapit@cgiar.org

Bill R. Gregg, Private Seed Industry Development Consultant, Starkville, Mississippi, USA, billgregg1@bellsouth.net

Bimal Baniya, Researcher, Nepal Agricultural Research Council (NARC), Khumaltar, Lalitpur, Nepal, baniyabk@hotmail.com

Bulcha Weyessa, Researcher, Holetta Research Center (HARC), Ethiopian Institute for Agricultural Research (EIAR), Addis Ababa, Ethiopia, bulcha_woyessa@yahoo.com

Cecile Kusters, Trainer/Consultant, Wageningen International, Wageningen UR, Wageningen, The Netherlands, cecile.kusters@wur.nl

Conny Almekinders, Associate professor, Wageningen University, Technology and Agrarian Development Chair Group, Wageningen, The Netherlands, conny.almekinders@wur.nl

Demissie Mitiku, Breeder, Ethiopian Institute for Agricultural Research (EIAR), Oromia, Ethiopia, demissie05@yahoo.com

Ehsan M. Dullo, Project Coordinator, Conservation of Agricultural Biodiversity, Bioversity International, Rome, Italy, e.dullo@cgiar.org

Endrias Geta, Researcher, Southern Agricultural Research Institute (SARI), Awassa, Ethiopia, endriasgetab@yahoo.com

Eshetu Sisay, Seed production and Extension division head, Ethiopian Seed Enterprise (ESE), Assela, Oromia, Ethiopia

Fetien Abay, Associate professor, Mekelle University, Mekelle, Tigray, Ethiopia, fetien.abay@yahoo.com

Fikre Mulugeta, Seed expert, Food and Agriculture Organization (FAO), Assela, Ethiopia, fikre62002@yahoo.com

Fred Ogana, Country Director, TechnoServe, Nairobi, Kenya, fogana@technoserve.or.ke

Fredy R. Sierra, Administrative manager, Foundation for Participatory Research with Honduran Farmers (FIPAH), La Ceiba, Atlántida Honduras, fipah@metro-red.hn

Gabriel Luyima, Technician, National Agricultural Research Organization (NARO)/ Uganda, National Banana Research Programme (UNBRP)/ National Crops Resources Research Institute (NaCRRI), Namulonge, Uganda, luyimagabriel@yahoo.com

Gemechu Keneni, Researcher, Holetta Research Center (HARC), Ethiopian Institute for Agricultural Research (EIAR), Addis Ababa, Ethiopia, gemechukeneni@yahoo.com

George A. Odingo, Agriculture Marketing Officer, Catholic Relief Services, Nairobi, Kenya, godingo@crskenya.org

Girma Balcha, Director General, Institute for Biodiversity Conservation (IBC), Addis Ababa, Ethiopia, dg-ibc@ethionet.et

Girma Chemedo, Farm manager, Oromia Agricultural Research Institute (OARI), Bako, Ethiopia, d.kumssa2003@yahoo.com

Goshime Tekle, Agricultural Input Inspection Expert, Ministry of Agricultural Rural Development (MoARD), Addis Ababa, Ethiopia, goshmeabel@yahoo.com

Hagos Gidey, Technician, Institute of Biodiversity Conservation (IBC), Addis Ababa, Ethiopia, hagoshiz@yahoo.com

Hannes Dempewolf, PhD student, University of British Columbia, Vancouver, Canada, h.dempewolf@gmx.de

Hans Smolders, Private consultant, Siriconsult, Zeewolde, The Netherlands, h.smolders@siriconsult.nl

Heleen Bos, Private Consultant, Aguadulce, Spain, heleen.bos@telefonica.net

Imiru Mijana, Team leader, Bureau of Agriculture and Rural Development (BoARD), Oromia, Ethiopia, bogale.tole@yahoo.com

Jean Claude Rubyogo, Seed Systems Specialist, International Center for Tropical Agriculture (CIAT)/ Pan-Africa Bean Research Alliance (PABRA), Lilongwe, Malawi, j.c.rubyogo@cgiar.org

Jean Marie Byakweli Vianney, Seed and PGR advisor, Institut des Sciences Agronomiques du Rwanda (ISAR), Belgian Technical Cooperation, Kigali, Rwanda, jmbyakweli@yahoo.com

Johannes M.M. Engels, Senior Scientist, Bioversity International, Rome, Italy, j.engels@cgiar.org

John F. MacRobert, Seed Systems Specialist, International Centre for Maize and Wheat Improvement (CIMMYT), Harare, Zimbabwe, j.macrobot@cgiar.org

John R. Witcombe, Senior Research Fellow, Center for Arid Zones Studies (CAZS) Natural Resources, University of Wales, Bangor, Gwynedd, United Kingdom, j.r.witcombe@bangor.ac.uk

Johnson W. Irungu, Agriculture Unit Manager, Catholic Relief Services, Nairobi, Kenya, jirungu@crskenya.org

José A. Jiménez, Senior researcher, Foundation for Participatory Research with Honduran Farmers (FIPAH), Yorito, Yoro Honduras, joseji_57@yahoo.com

Juliana Bernardi Ogliari, Professor, Federal University of Santa Catarina (UFSC), Florianópolis, Brazil, jbogliar@cca.ufsc.br

Karèn S. Verhoosel, Trainer/Consultant, Wageningen International, Wageningen UR, Wageningen, The Netherlands, karen.verhoosel@wur.nl

Kazi Borhan Amin Raj, Managing Director, Seba Limited Bangladesh, Dhaka, Bangladesh, raj@sebalimited.com

Koffi Amegbeto, Seed Economist, Seed Unit, International Centre for Agriculture in Dry Areas (ICARDA), Aleppo, Syria, k.amegbeto@cgiar.org

Krishna D. Joshi, Research Coordinator, Center for Arid Zones Studies (CAZS-NR) Regional Office for South Asia, Kathmandu, Nepal, kdjoshi@mos.com.np

Krishna P. Devkota, Senior Programme Officer, Local Initiatives for Biodiversity, Research and Development (LI-BIRD), Pokhara, Nepal, kdevkota@uni-bonn.de/kdgorkha@yahoo.com

Losira Nasirumbi, Socio-economist/Researcher, National Agricultural Research Organization (NARO)/ Uganda, National Banana Research Programme (UNBRP)/ National Crops Resources Research Institute (NaCRRI), Namulonge, Uganda, nasirumbil@yahoo.com

Madhusudhan Upadhyay, National project coordinator, Nepal Agricultural Research Council (NARC), Khumaltar, Lalitpur, Nepal, iscc_nepal2@wlink.com.np

Mahanaryan Yadav, Chairperson/Farmer, Agriculture Development and Conservation and Society, Kachorwa, Bara, Nepal

Mahendra P. Tripathi, Project officer, Local Initiatives for Biodiversity, Research and Development (LI-BIRD), Pokhara, Nepal, mptripathi@gnet.com.np

Marja H. Thijssen, Trainer/Consultant, Wageningen International, Wageningen UR, Wageningen, The Netherlands, marja.thijssen@wur.nl

Mary W.K. Mburu, Project Manager (Lucrative Legume Project), The International Crops Research Institute for the Semi-Arid Tropics (ICRISAT), Nairobi, Kenya, m.w.mburu@cgiar.org

Mata Gedebo, Seed production & Extension section head, Ethiopian Seed Enterprise (ESE), Awassa, Ethiopia

Messele Shimels, Senior Market Study, Ethiopian Seed Enterprise (ESE), Addis Ababa, Ethiopia, mestasew@yahoo.com

Michael A. Ugen, Principal Research Officer (Agronomist), National Agricultural Research Organization (NARO)/ Uganda, National Banana Research Programme (UNBRP)/ National Crops Resources Research Institute (NaCRRI), Namulonge, Uganda, michaelugen@yahoo.com/m.ugen@naro-ug.org

Muez Teare, Agronomist, Bureau of Agriculture and Rural Development (BoARD), Mekele, Tigray, Ethiopia, mueztg@yahoo.com

Musa Jarso, Researcher, Holetta Research Center (HARC), Ethiopian Institute for Agricultural Research (EIAR), Addis Ababa, Ethiopia, mjarso@yahoo.com

Niels Louwaars, Senior Scientist Biopolicies, Wageningen International/ Center for Genetic Resources (CGN), Wageningen, The Netherlands, niels.louwaars@wur.nl

Omar Gallardo, Regional coordinator Otoro, Foundation for Participatory Research with Honduran Farmers (FIPAH), Otoro, Intibucá, Honduras, oogallardo76@yahoo.com

Osman E. Ibrahim, Chief Technical Advisor, Seed Security project FAO, Addis Ababa, Ethiopia, osmanibra@softhome.net

Pablo Eyzaguirre, Senior Scientist, Bioversity International, Rome, Italy, p.eyzaguirre@cgiar.org

Pashupati Chaudhary, Scientist Biology department, University of Massachusetts Boston, Boston, USA, pashupati.chaudhary@umb.edu

Pitamber Shrestha, Project officer, Local Initiatives for Biodiversity, Research and Development (LI-BIRD), Pokhara, Nepal, pitamber97@hotmail.com/pitambar@libird.org

Pratap Shrestha, Executive Director, Local Initiatives for Biodiversity, Research and Development (LI-BIRD), Pokhara, Nepal, pshrestha@libird.org

Ram Rana, Senior Programme Officer, Local Initiatives for Biodiversity, Research and Development (LI-BIRD), at present: Researcher, University of Reading, Reading, United Kingdom, r.b.rana@reading.ac.uk

Richard B. Jones, Assistant Director, International Crops Research Institute for the Semi-Arid Tropics (ICRISAT), Eastern and Southern Africa, Kenya

Robert J. Lewis-Lettington, Genetic Resource Policy Initiative (GRPI) Coordinator, Bioversity International, Nairobi, Kenya, r.lettington@cgiar.org

Said N. Silim, Regional Director, International Crops Research Institute for the Semi-Arid Tropics (ICRISAT), Eastern and Southern Africa, Nairobi, Kenya, s.silim@cgiar.org

Sally Humphries, Associate professor, University of Guelph, Guelph, Ontario, Canada, shumphri@uoguelph.ca

Severin Polreich, Phd student, Georg-August-University Göttingen, Institute for Crop & Animal Production in the Tropics, Göttingen, Germany, sepolreich@yahoo.com

Shemsu Baissa, Seed Quality Control Division Head, Ethiopian Seed Enterprise (ESE), Bale, Oromia, Ethiopia, shemsuba@yahoo.com

Solomon Benor, Lecturer and Researcher, Hawassa University, Awassa, Ethiopia, solomonbenor@yahoo.com

Soniia David, Extension specialist, Sustainable Tree Crops Programme (STCP), International Institute for Tropical Agriculture (IITA), Accra, Ghana, s.david@cgiar.org

Tadesse Teweldebrhan, Center manager, Ethiopian Seed Enterprise (ESE), Mekelle, Tigray, Ethiopia, tadetewe@yahoo.com

Tadesse Wube, Agricultural Input Development & Study Expert, Ministry of Agricultural Rural Development (MoARD), Addis Ababa, Ethiopia, tadesse_w@yahoo.com

Tefera Zera, Agronomist, Bureau of Agriculture and Rural Development (BoARD), SNNPR, Awassa, Ethiopia, teff_99@yahoo.uk

Tesfaye Tadesse, Researcher, Southern Agricultural Research Institute (SARI), Awassa, Ethiopia, tesfayet2@yahoo.com

Tessema Tanto, Researcher, Institute for Biodiversity Conservation (IBC), Addis Ababa, Ethiopia, tesemat@yahoo.com

Trygve Berg, Associate professor, Norwegian University of Life Sciences (NORAGRIC), Ås, Norway, trygve.berg@umb.no

Walter S. de Boef, Consultant/Trainer, Wageningen International, Wageningen UR, Wageningen, The Netherlands/ Visiting professor, Federal University of Santa Catarina (UFSC), Florianópolis, Brazil, wboef@tulipane.com

Woldehawariat Assefa, Input regional team leader, Bureau of Agriculture and Rural Development (BoARD), Mekelle, Tigray, Ethiopia, wassefafesseha@yahoo.com

Yimam Tessema, Manager, Private Seed Company, Bahir Dar, Ethiopia

Yonas Sahlu, Head Seed Quality Control Service, Ethiopian Seed Enterprise (ESE), Addis Ababa, Ethiopia, sahlu_yonas@yahoo.com

Zenebe W/Silase, Seed production and extension section head, Ethiopian Seed Enterprise (ESE), Bale, Oromia, Ethiopia, e.s.e@ethionet.et

Zewdie Bishaw, Head Seed Unit, International Centre for Agriculture in Dry Areas (ICARDA), Aleppo, Syria, z.bishaw@cgiar.org

Introduction

Ethiopia, located in the Greater Horn of Africa, has an estimated area of 112 million ha, of which 65% is suitable for arable agriculture. At present 15% of the area is cultivated for the production of major food crops. About 85% of its 70 million people are dependent on agriculture for their livelihoods. The Government of Ethiopia gives high priority to increasing the agricultural production and productivity in order to ensure food security, improve rural livelihoods and promote industrial development and growth. In this context, a well functioning seed system, providing the farmers with improved seeds of varieties of their choice is of paramount importance.

In Ethiopia, as in many other countries in sub-Saharan Africa, the informal seed system is still the dominant system for seed supply: it is the system in which farmers select their crops and varieties, produce their own seeds, and/or locally exchange and purchase seeds. The proportion of seed supplied by the formal seed system is estimated to be around 10%. Ethiopia's rich diversity in crops and varieties is vital for sustaining the livelihoods of subsistence farmers in the country's diverse, complex and risk-prone environments; yet for some important crops the area covered with improved varieties is estimated to be less than 5%. There is a continuous process of exchange between the formal and informal systems, in information, in technology and, above all, in germplasm.

Objectives of the book

This book addresses strategies and approaches through which professionals can support informal seed supply. These professionals work in seed sector development, crop improvement and genetic resources management, or more generally in research and extension. The book also presents strategies for linking the support of informal seed supply with the conservation and use of the huge genetic resource base of crops and local varieties.

The book is an output of the tailor-made training on the improvement of farmer-based seed production and revitalization of the informal seed supply of local crops and varieties in Ethiopia. The papers were written by the trainers, resource persons and participants of the one-year training programme. A number of additional papers cover interesting case studies and the experiences of experts in other regions of the world. In this book we try to document and share the learning process of the training. The lessons learnt may be inputs in the further upscaling of approaches and strategies in supporting informal seed supply. We hope that the experiences will serve as an input in the discussions on the strategies and approaches for seed sector development, with the formal and the informal seed systems recognized for their own strengths and their complementarities. We hope that the book will contribute to the seed policy discussion, enabling the creation of policy regulatory frameworks that recognize farmers' complex reality and the role of the informal seed system in seed supply, and stimulate formal sector organizations to get involve in activities

supporting informal seed supply. We hope that the book will be of use to professionals in Ethiopia and beyond.

Outline of the book

The book consists of seven chapters which address informal seed supply from different perspectives. Generally, each chapter introduces one or two concepts and strategies, followed by related case studies from Ethiopia and relevant experiences in other countries of sub-Saharan Africa and of the world.

The book starts with a general chapter, presenting the status and organization of the Ethiopian seed sector, a systems perspective on formal and informal seed supply, participatory and learning-oriented approaches, and the training programme on supporting informal seed supply. The chapter also offers a synthesizing concept which integrates all the strategies described in the book: the concept of robust seed systems. Chapter 2 primarily targets supporting farmers' management of seeds, or the informal seed system. This concerns often technical interventions enhancing seed quality and/or farmers' access to quality seed of improved or desired local varieties. Chapter 3 adopts a conservation point of view on approaching seed supply, focusing clearly on promoting the use of local varieties and crops. Chapter 4 highlights participatory approaches in crop research and plant breeding; seed primarily appears as the tool for disseminating improved or farmers' preferred local varieties. Chapter 5 addresses approaches to establishing small-scale or community-based seed producer groups or enterprises; Chapter 6 presents initial efforts to establish such seed enterprises and production groups in Ethiopia. This strategy focuses on organizing farmers and takes a market/business approach to increasing seed availability and enhancing seed access. Finally, Chapter 7 outlines opportunities to enable the design of policy frameworks that support informal seed supply.

1 Context and concepts

1.1 The status of the Ethiopian seed industry¹

Zewdie Bishaw, Yonas Sahlu and Belay Simane

Ethiopian agriculture is characterized by subsistence farming and small landholdings. Per capita, landholdings are smaller in high potential areas inhabited by the majority of farmers than in areas of lower potential. The national average for annual crops is only 0.8 ha (Table 1.1). Individual plots are fragmented into several smaller parcels with an average of three parcels per holding. Most farmers in the northern and central highlands own even smaller areas and grow diverse crops and varieties.^{2,3}

Table 1.1 Area and land holdings of farmers in Ethiopia⁴

<i>Land use</i>	<i>Area (ha)</i>	<i>Area (%)</i>	<i>No of holders</i>	<i>Average area per holder (ha)</i>	<i>Average area per parcel (ha)</i>
Annual crops	8,193,391	74.2	10,151,839	0.81	0.3
Perennial crops	667,768	6.0	5,805,161	0.12	0.09
Pastures	957,856	8.7	3,723,319	0.26	0.2
Fallow	839,949	7.6	3,278,341	0.26	0.19
Wood lands	87,053	0.8	1,486,960	0.06	0.05
Others	301,232	2.7	10,226,668	0.03	0.05
Total	11,047,249	100	10,758,597	1.03	0.31

The use of improved seeds is at very low levels. In 2002, improved seeds were used in less than 3% of the total cultivated area (Table 1.2). The Ethiopian Seed Enterprise (ESE), a public enterprise which is the main provider of seeds in the country, supplies less than 20,000 tons of seed per year. For smallholder farmers, the biggest constraints are high seed prices and late delivery, exacerbated by poor rural infrastructure making it hard to reach farmers in remote and isolated villages. Access to and use of seeds are critical factors for the ability of smallholder farmers to increase agricultural production and productivity, ensuring food security and improving livelihoods. This section presents the general context of seed supply to smallholders and subsistence farmers in Ethiopia. It describes the formal seed system through its history, stakeholders and structure, and examines its performance in contributing to seed availability and access. The section also briefly sketches the background of the informal seed system, and concludes by sharing some key issues requiring attention if we are to succeed in enhancing seed availability and access in Ethiopia.

Table 1.2 Area planted with improved seeds and fertilizers in Ethiopia (2005/2006)

<i>Crops</i>	<i>Total area (ha)</i>	<i>Area covered with</i>			
		<i>Improved seeds</i>		<i>Fertilizers</i>	
		<i>Area (ha)</i>	<i>%</i>	<i>Area (ha)</i>	<i>%</i>
Cereals	8,463,080	335,369	4.0	4,330,710	51.2
Pulses	1,378,939	5,025	0.4	274,915	19.9
Oil crops	740,847	4,056	0.6	76210	10.3
Vegetables	95,194	559	0.6	66,349	69.7
Root crops	188,917	2114	1.1	118,229	62.6
Others (temporary)	97,677	102	0.1	32,814	33.6
Total	10,964,654	347,225	3.2	4,899,227	44.7

Source: Central Statistics Authority, 2007.

The formal seed system

The formal seed system aims to supply adequate amounts of seed of high quality, at the right time and place, and at reasonable prices. Currently the share of the formal seed system is estimated to be about 10-20% while the rest (80-90%) is covered by the informal system.

Historical background

In Ethiopia, the formal seed system started five decades ago as an ad hoc extension activity by academic and crop research institutions. In 1942, Jimma Agricultural College (then Jimma Agricultural School) was the first to start improved seed production and distribution. As early as 1954, the Alemaya College of Agriculture (now Alemaya University of Agriculture) used to distribute seed to farmers, and the Institute of Agricultural Research (now Ethiopian Institute of Agricultural Research) followed suit when it was established in 1966. Later on, the Chillalo Agricultural Development Unit began to produce and supply seed to serve farmers in Chilalo 'awraja' and later Arsi region and its surroundings. Meanwhile, in the late sixties and early seventies, many private large-scale commercial farms flourished, which were eventually nationalized by the government. And in some parts of the country, the government established new state farms, based on socialist principles. Consequently, farmers' producers' cooperatives were also organized and farmers' resettlement projects were launched by the government.

These developments led to increased demand for modern agricultural inputs, particularly improved seeds. While provision of other agricultural inputs from local and foreign sources was possible, improved seed supply was lacking as there was no organized system in the country until the government established the Ethiopian Seed Enterprise (ESE; then the Ethiopian Seed Corporation) in 1979. Initially, the ESE was given responsibility for supplying seed to the entire farming community through local production or imports from abroad. Although its activities were largely skewed to the state farms and cooperatives at the expense of small farmers, the establishment of the ESE did lead to the advent of an organized seed production and supply system. Since then, the ESE has remained the main seed producer and supplier in the formal sector.

National seed policy and regulatory frameworks

It should be noted that the national seed policy and regulatory frameworks were realigned with rural development policies and strategies issued by the government in 2001. This section gives the highlights, and Section 7.2 provides details in relation to the informal seed sector.

National seed policy

The first National Seed Industry Policy was issued by the government in 1992, focusing on the following key areas: (i) plant genetic resources conservation and development; (ii) crop variety development, testing and release; (iii) seed production and supply; (iv) seed import and export; and (v) reserve seed stock.

The main objectives set by the policy are to:

- Ensure the plant genetic resources collection, conservation, evaluation and use by the national research and development programs;
- Enhance and streamline variety development, evaluation, release, registration and maintenance;
- Develop an effective system for producing and supplying high quality seeds of important crops to satisfy the national seed requirements;
- Encourage the participation of farmers in germplasm conservation as well as in seed production and supply systems;
- Create a functional and efficient organizational setup to facilitate collaborative linkage and coordination in the seed industry;
- Regulate seed quality standards, import and export, seed trade, quarantine and other seed-related issues.

Seed regulatory frameworks

Several proclamations were issued to legally enforce and implement various activities underlined in the national seed industry policy. They included the Plant Protection Decree (No. 56/1971), the Plant Quarantine Regulation (No. 4/1992), the Plant Breeders' Rights Proclamation (No. 481/2006), and the Access to Genetic Resources and Community Knowledge and Community Rights Proclamation (No. 482/2006). The most important of them all was the National Seed Proclamation No. 206/2000, which aimed at: (i) creating a legal framework for the protection of the interests, and control, of the users, originators, processors, wholesalers and retailers of plant seeds; (ii) designating government agencies which support, advise and control individuals/organizations engaged in the production, processing, import, export, sale and distribution of quality seeds; and (iii) promoting the use of quality seed through a smooth, effective and quick supply system.

Moreover, major stakeholders were also reconstituted into new legal entities through various proclamations and regulations including the EIAR (Proclamation No. 79/1997), the Institute of Biodiversity Conservation (IBC, Proclamation No. 120/1998) and the ESE (Regulation No. 154/1993). In 2004, Proclamation No. 380/2004 gave MoARD the authority to supervise all government organs dealing with seed regulation, seed production and seed distribution.

Stakeholders and roles

The formal seed sector comprises both public and private organizations, including the Institute of Biodiversity Conservation (IBC), the Ethiopian Institute for Agricultural Research (EIAR), Regional Agricultural Research Institutes (RARIs: research organizations operating within the regional states), Universities, the Ethiopian Seed Enterprise (ESE), Pioneer Hybrid Seed Ethiopia (PHSE), several small-to-medium scale private seed farms and the farmers. Other relevant stakeholders are the Ministry of Agriculture and Rural Development (MoARD), the Bureaus of Agriculture and Rural Development (BoARDs: the regional state extension bodies), farmers' cooperative unions (FCUs) and NGOs. Table 1.3 shows the key stakeholders in the formal seed sector. However, it should be noted that the MoARD is being reorganized where the main responsibilities and activities will be retained, but are realigned within new coordination offices or organizational units of the Ministry.

Table 1.3 The formal seed system and its stakeholders

<i>Seed system components</i>	<i>Involved stakeholders</i>	<i>Regulatory stakeholders</i>	<i>Regulatory measures</i>
Plant breeding	EIAR, RARIs and universities		
Variety release	National Variety Release Committee	MoARD	Distinctiveness, uniformity and stability, uniqueness, value for cultivation
Breeder seed production	EIAR, RARIs and universities		
Pre-basic seed production	EIAR, RARIs, universities and ESE		
Basic seed production	ESE and private seed companies	MoARD	Seed quality assurance
Certified seed production	ESE, private seed farms, farmer based seed production	MoARD	Seed quality assurance
Farmer based seed production	ESE, BoARD, NGOs and farmers		
Use of seed for grain production	Farmers	Ethiopian Grain Trade Agency	Grain quality

Variety development has long been the sole responsibility of the EIAR. Since research decentralization, RARIs have increasingly been commissioned to develop varieties suitable for their regions. Moreover, agricultural universities and colleges are contributing to variety research and development. The variety release mechanism is still controlled at a federal level.

The EIAR and the RARIs produce breeder seed and parental lines; the EIAR and the ESE are responsible for pre-basic and basic seed supply. The ESE is the major seed producer in the formal seed system, and owns four seed farms where it produces largely pre-basic and basic seeds of different crop varieties (Table 1.4). These

farms, however, could not produce all the required early generation seed, due to limitations in crop adaptation. Therefore, the EIAR fills the gap in the supply through its regional branches, which better represent the various agro-ecologies. The shortage of pre-basic and basic seed has continued to pose problems in the seed industry. The role of private seed companies is still limited to the production of hybrid maize seed, while the ESE is the main public sector seed producer and supplier of other crops and varieties. BoARDs and some NGOs help small farmers with informal seed production and supply. Emergency seed programs are usually implemented by NGOs and relief agencies.

Table 1.4 Ethiopian Seed Enterprise's seed production farms

<i>Seed farm</i>	<i>Location</i>	<i>Area (ha)</i>	<i>Altitude (m)</i>	<i>Average rainfall (mm)</i>	<i>Main crops</i>
Gonde Eteya BSF	Arsi	400	2150	800	Highland
Shallo BSF	W. Arsi	1018	1700	842	Low - medium land
Kunzila BSF	W. Gojam	509	1800	NA	Low - medium land
Ardayta Seed F	Arsi	3116	2500	812	Highland

MoARD is an umbrella organization which coordinates and leads the various activities of the seed industry. The main tasks of MoARD's various departments include the national seed policy, variety registration and release, seed import/export, seed certification, quarantine and extension. Previously, the responsibility for official seed quality control and certification was given to the now defunct National Seed Industry Agency (NSIA). To date, it is handled by the Agricultural Inputs Quality Control Department of MoARD, which is now being restructured. BoARDs in regional states and FCUs play a vital role in seed distribution while credit is offered by various financial institutions through FCUs. The FCU's share in seed supply to small farmers is now growing very rapidly. At present the role of private seed dealers is very limited. Seed companies distribute seed through selected local private dealers. The current big shortfall in hybrid seed supply triggers several fraudulent practices. The linkages among the seed industry stakeholders are not strong, although there are some forums which bring them together occasionally. Forums created by organizations for variety release and research, extension, and the farmers' advisory council demand stakeholders' active participation in exchanges of information and experiences in these areas.

Seed production facilities

The formal seed sector has built up its seed processing capacity over the past two and a half decades. Currently there are more seed processing facilities than are needed in the sector, whereas storage and transport facilities are very limited. Most of the facilities are owned by the ESE but are not located strategically for serving small farmers throughout the country (Table 1.4 and 1.5). Besides the ESE, Pioneer Hi-Bred Seeds Ethiopia owns a seed processing plant with an annual capacity of 6,000 tons and a seed storage facility of 2000 tons – both located in Addis Ababa.

Seed quality assurance

Seed quality assurance was the first concern of the formal seed production sector. The seed quality assurance department was established within the ESE structure from the outset, and many staff were trained, both in-country and abroad. Although it was not legally sanctioned, the ESE developed, adopted and abided by internal field and laboratory quality standards. The ESE operates a central seed testing laboratory at headquarters and five mini laboratories attached to seed processing plants and storage facilities located in different regions (Table 1.5). ESE has kept its internal seed quality assurance activities even after the introduction of formal seed certification under the MoARD. Remarkable progress has been recorded in improving the seed quality since the early days when seed users identified problems of physical purity (inert matter, broken seeds) and varietal purity. The ESE has now strengthened its internal quality assurance and improved the quality of the seed it produced.

Table 1.5 Seed processing, storage and laboratory facilities in Ethiopia

<i>Institute/ location</i>	<i>Seed processing (tons)</i>		<i>Seed testing laboratory (samples tested/year)</i>	<i>Storage (tons)</i>
	<i>Per hour</i>	<i>Seed processed/year</i>		
<i>ESE</i>				
Addis Ababa	-	-	5,000	-
Asela	3.0	24,192	2,500	5,000
Koffele	3.0	24,192	2,500	3,700
Awassa	5.0	40,320	2,500	4,300
Nekempte	2.5	20,160	2,500	5,000
Mobiles (4)	7.0	12,960	-	-
Assassa	-	-	-	4,000
Dodola	-	-	-	4,000
Kombolcha	-	-	-	2,000
Robe	-	-	-	4,000
Bahrdar	2.0	16,128	2,500	4,000
Gonde	-	-	-	1,500
Sub-total	-	137,952	17,500	39,600
<i>Pioneer</i>				
Addis Ababa		6,000		2,000
Total		143,952		41,000

The Agricultural Inputs Quality Control Department of MoARD uses its main seed testing laboratory located in Addis Ababa and 10 mini seed testing laboratories located in different zones (Ambo, Asela, Axum, Dessie, Durame, Durbete, Gondar, Markos, Mekele and Wolayta) for seed certification purposes. The mini seed laboratories and the central laboratory have a combined capacity to test 25,000 samples per year. Currently limited testing capacity makes it impossible to fulfil the requirement that all seed be certified. Decentralizing seed quality assurance by using these laboratories may help to address this problem.

Performance of the formal seed system

After almost three decades of operation, the formal sector could not adequately satisfy the seed demand of the vast majority of the nation's farmers who are smallholders and subsistence farmers. The ESE remains the major public sector seed producer and supplier in the country. Although the government allowed any legal domestic entity to access varieties developed by the public institutions, the role of private seed companies did not expand as expected. There are very few private companies, and they are exclusively engaged in hybrid maize seed production. The involvement of foreign companies is low: Pioneer Hi-Bred Seeds Ethiopia's share in the hybrid maize seed market is limited.

Table 1.6 Annual seed sales by the Ethiopian Seed Enterprise (2000-2007)

<i>Crop</i>	<i>Annual seed sales (quintals)</i>							
	2000	2001	2002	2003	2004	2005	2006	2007
Wheat	125286	55605	7934	91393	138913	64234	115886	75006
Barley	427	375	535	1580	4198	3710	10022	6355
Teff	3784	973	509	1620	1329	2072	3529	5816
Maize	71198	54767	25682	59124	50204	48792	46650	54747
Sorghum	-	11	63	-	95	443	140	278
Millet	-	-	-	-	12	37	26	234
Haricot bean	156	376	884	2300	2170	2486	4370	2238
Faba bean	25	152	66	315	495	1076	2231	2720
Field pea	120	38	85	247	2230	3269	796	1388
Soybean	112	145	-	-	157	30	812	1705
Lentil	-	4	57	31	327	7293	1883	664
Chickpea	67	254	106	207	358	2158	2208	1346
Linseed	158	65	170	337	670	497	586	289
Rapeseed	210	19	20	23	407	126	49	707
Sesame	-	-	-	-	438	339	486	67
Cotton	-	-	-	-	6936	8	238	179
Total	201,543	112,784	36,111	157,177	208,951	136,721	189,993	153,809
Area coverage by CS ¹	383,550	260,948	112,328	308,071	350,418	272,727	304,047	312,336
Potential seed demand ²	1,328.9	1,532.9	1,303.5	1,331.6	1,438.3	1,719.6	1,713.4	1,769.4
CS coverage ³	15.2	7.4	2.8	11.8	14.5	15.9	11.1	8.7

Notes: 1 quintal = 100 kg; CS = certified seed; Potential seed demand is computed using primary data from the National Statistical Bulletins (2000-2007); ¹ Area coverage in ha; ² Potential seed demand * 10³ q; ³ CS coverage in %. Source: ESE, Marketing Department.

The ESE seed cleaning and selling centres are not located strategically for serving small farmers in potential crop production areas. Rather they are situated near state farms where most of the seed is produced and used. This situation also led to weak seed marketing, which hindered the enterprise's development, whether directly or indirectly. A recent sales record of the enterprise shows that the annual seed sales seldom reach 200,000 quintals (Table 1.6).

Table 1.7 Crop varieties and certified seed production by the ESE (2003-2006)

<i>Crop</i>	<i>No. of varieties released (since 1994)</i>	<i>No. of varieties produced (2003-06)</i>	<i>Average area for seed production (ha)</i>	<i>Major dominant variety</i>	<i>% share of area for seed production</i>	<i>Year of release</i>
Bread wheat	27	17	3562	HAR 1685	37.3	1995
Durum wheat	22	10	121.7	Kilinto	33.8	1994
Maize (H)	7	7	1293.1	BH 660	49.7	1993
Maize (OP)	12	4	891.7	Katumani	73.4	1974
Teff	18	5	766.7	Cross 37	52.7	1984
F. Barley	17	3	552.7	HB 42	63.3	1984
M. Barley	2	4	323.3	Holker	60.8	1979
H. beans	3	8	502.1	A. Melka	44.3	1998/99
Faba bean	11	5	361.7	CS 20DK	55.7	1977
Chickpea	6	4	190.1	Arreerti	62.6	1999/00
Field pea	17	4	179.6	Tegegnech	89.0	1993/94
Lentil	6	1	172.3	Alemaya 98	100.0	1997/98
Mustard	5	1	552.0	Y. Dodola	100.0	1984
Linseed	5	5	190.4	CI 1525	39.0	1986
Total	158	78	9658.4			

Source: ESE and Crop Variety Register Issue No. 9.

Many relief and development efforts have been aimed at helping to make improved seed available within the small farming communities. NGOs have often undertaken emergency seed distribution, especially during severe drought years, and many continue to do so.* Such activities have often not been well planned, however, and have proved unsatisfactory in solving seed supply problems.

Formal seed production was not systematically organized until the ESE acquired the first two basic seed farms in 1989. This made it possible to introduce a generation system into seed production and helped in defining the roles of other stakeholders in the seed industry. During the last eight years, the ESE's seed sales have been dominated by wheat and maize, which account for more than 90% of sales (Table 1.7). There are many reasons why seed sales were skewed to these two crops. First, they are major food crops and are needed in larger quantities in the country. Second, international agricultural research organizations have supported their improvement, resulting in the development of many superior varieties (Table 1.8). Third, the higher productivity encouraged farmers to adopt and produce these varieties, replacing other crops such as barley and sorghum.

* Asrat Asfaw, Anbese Tenaye and Endrias Geta describe the impact of such seed relief operations on the informal seed system in Section 2.5.

Table 1.8 List of varieties released and currently available for seed production

<i>Crop</i>		<i>Agro-ecology</i>			<i>Total</i>
		<i>Irrigated</i>	<i>High rainfall</i>	<i>Low rainfall</i>	
Cereals	Bread wheat	1	34	--	35
	Durum wheat	--	26	--	26
	Malt barley	--	8	--	8
	Food barley	--	21	--	21
	Teff	--	18	7	25
	Maize (hybrids)	--	15	--	15
	Maize (OPVs)	--	11	7	18
	Sorghum	--	17	4	21
	Finger Millet	--	4	--	4
	Sub-total	1	154	18	173
Legumes	Faba bean	--	17	--	17
	Field pea	--	23	--	23
	Chickpea	--	7	--	7
	Lentil	--	8	--	8
	Haricot bean	--	21	--	21
	Sub-total	--	76	--	76
Oilseeds ¹	Linseed	--	8	--	8
	Rape seed	--	8	--	8
	Sesame	--	10	--	10
	Soya bean	--	9	--	9
	Ground nut	--	13	--	13
	Sub-total		48		48
Vegetables	Pepper	--	6	--	6
	Tomato	10	--	--	10
	Onion	--	4	--	4
	Potato	--	22	--	22
	Sub-total	10	32	--	42
Fibres	Cotton ²	13	13	--	13
	Grand total	24	323	18	352

Notes: ¹Soya bean and peanut are usually considered as oilseed crops;

²Suitable for both irrigated and rain-fed agriculture.

The informal seed system

Ethiopia is known for its agro-ecological and biological diversity. Ethiopian farmers have a long tradition of settled agriculture contributing to the evolution and maintenance of the country's rich agrobiodiversity, and to a well entrenched informal seed system. Farmers use centuries-old strategies, including the improvement of farmer-saved seeds, farmer-to-farmer seed exchange, and farmer-managed seed production. The seed production-distribution chain in the informal seed system is short and simple, without any regulation. Although the formal seed sector started some five decades ago, it still remains limited to a few major crop varieties developed by agricultural research. As a result, the informal sector remains the major supplier of seed of improved and local varieties for many crops grown by small-scale farmers. At

present, the formal sector meets on average less than 10% of the country's potential seed demand. Some attempts have been made to improve seed supply by working with farmers through contractual seed production with Farmers' Producers Cooperatives and through farmer-based seed production and marketing units (set up first by the NSIA and lately by the ESE and regional BoARDS).^{*} Improving farmer-based seed production schemes and revitalizing informal seed supply for local crops and varieties is crucial for the development of the seed sector in the country. Supporting the informal seed sector will help to maintain genetic resources and to increase productivity so as to attain food security and improve farmers' livelihoods.

Constraints faced within the seed sector

In assessing the performance and structure of the Ethiopian seed industry, we can identify two groups of constraints: policy/regulatory and technical constraints.

Policy and regulatory constraints

The national seed policy and relevant laws and regulations have not been revisited and amended to keep up with new developments in the industry. A number of articles need to be amended, particularly with regard to seed quality standards, which are very high for some crops. The Seed Law No. 206/2000 demands conformity with these standards for any commercial seed. It proved impossible to achieve such standards at the current stage of development in the seed sector. This concern was noted by the responsible agency but no practical action is taken yet.

Another major constraint is the inefficiency of the executing agencies. There are serious problems in implementation, although the seed sector has now better legal frameworks. Repeated restructuring of the executing agencies left the responsibilities shared among various departments of the MoARD, which is now being reorganized. This weakened the enforcement and serious fraudulent practices were reported by some suppliers. It is important that the quality assurance is strengthened so as to enforce the seed laws and prevent malpractices which have very serious repercussions for the agricultural sector.

Technical constraints

The shortage of varieties and their limited stability is a serious technical constraint. Few crop varieties are available for less favourable, drought-prone environments. Varieties maintained by farmers lack varietal stability. Many wheat and maize varieties quickly became susceptible to major diseases (e.g. rust in wheat). This has caused disappointment among farming communities who have adopted new varieties. An additional constraint relates to seed extension and popularization, which is inadequate. Variety popularization and seed promotion by various organizations is low in proportion to the vast number of farming communities in Ethiopia. Many improved varieties are not known by farmers, and seed production in the formal sector is

^{*} Yonas Sahlu, Belay Simane and Zewdie Bishaw describe and analyse the farmer-based seed production and marketing programme, providing important insights into its efforts in Section 1.2.

restricted to a very few varieties. Meanwhile, the private sector's participation in the seed industry is negligible and is currently limited to hybrid maize.

Appropriate action needs to be taken to address the various constraints and promote private sector participation. Land scarcity results in problems for contract seed multiplication. The ESE and other seed producers find it difficult to expand seed production as desired because suitable and experienced state farms have switched to growing more profitable crops, and there is limited early generation seed available. The amounts of breeder, pre-basic and basic seed produced by the EIAR and the ESE fall far short to satisfy the existing certified seed production scheme. Commercial seed companies cannot perform well without adequate supplies of basic seed. Advanced seed technology training and seed related research are limited; both issues are critical to efforts to solve outstanding problems in seed production and supply.

1.2 The farmer-based seed production and marketing scheme: lessons learnt

Yonas Sahlu, Belay Simane and Zewdie Bishaw

Background on availability and access to seeds

In order to prioritize the increased use of seeds of improved varieties and to attain fast and sustainable agricultural development in the country, the Ethiopian Government has identified improving the efficiency of the seed system as the most effective means of meeting the Millennium Development Goals.⁵ A seed marketing study of November 2000 commissioned by the Ethiopian Seed Enterprise (ESE) indicated that the potential size of the certified seed market in the country ranges from 0.75 to 1.0 million quintals per year. On the other hand, the current size of the penetrated market is about 0.2 million quintals per year.⁶ Clearly this difference between demand and supply means that the formal seed sector cannot ensure farmers easy access to seeds of improved varieties. About 60-70% of seed used by Ethiopian smallholders' farmers is saved on-farm, and the remaining 20-30% is borrowed or purchased locally. The share of improved seed is only around 10%.

Over the period 2000-2006, the ESE sold an aggregate average of 15,105 tons of certified seed per year. The total annual seed production over the period ranged from 3,611 tons (2002) to 20,895 tons (2004) (See Table 1.6 in Section 1.1). The seed supply market in Ethiopia is dominated by wheat and maize, which account for about 90%. The share of wheat remains stable while that of maize is increasing. Table 1.6 in the previous section provides more detailed information on the ESE's seed sales. The present demand estimation method used by the Agricultural Inputs Marketing Department of the Ministry of Agricultural Research Development (MoARD) is no more than an expert estimate. Prospective users are not normally contacted in advance to get a better understanding of demand and plan seed production and supply accordingly. The existing seed market is more supply-oriented than demand-driven.

This section shares experiences of working with farmers in seed production and marketing. It elaborates the methodology used for increasing the quantity of seed available and farmers' access to seeds of improved varieties through the Farmer Based Seed Production and Marketing Scheme, as implemented on a large scale in Ethiopia since 1997. The section explains the justification and background for working with this approach, shares experiences from several regions, and in conclusion outlines some constraints and opportunities for the future linking the formal and informal systems of seed supply with this approach.

PASDEP and seed supply

The Plan for Accelerated and Sustainable Development to End Poverty (PASDEP)⁵ aims to support the farmers' private initiatives and supports the shift to diversification and commercialization in agriculture. It is realized in PASDEP that, 'parallel to this shift to commercialized agriculture, improvement of pro-poor subsistence farming still needs to take place as the main welfare improvement for several million households which still depend on achieving higher yields of basic food grains'.⁵ PASDEP aims to attain 20 million tons of food grain production by the end of its five-year period, and projects that the area under improved varieties of field crops will reach 4.6 million ha. With this in mind, the total production of improved seeds for the main field food crops such as the major cereals, food legumes and oilseeds will need to reach about 55,400 tons.

Achieving these targets requires a concerted effort by all stakeholders to promote both the formal and informal seed systems in the country. In addition to technical and financial support, all stakeholders see the importance of revisiting the seed policy and regulations and the existing setups, in order to establish a sustainable seed value chain system. The key problems faced are (i) high production and distribution costs related to consistently low levels of effective demand, and to the high cost of transport from centralized seed production facilities to rural areas; (ii) a relatively narrow range of crops/varieties that do not meet smallholder needs; (iii) inconsistent seed quality; and (iv) limited capacity to enforce and harmonize the seed policy and legislations. Given the critical role that improved varieties play in increasing agricultural production, a key question is how to facilitate the development of a seed system that is capable of generating, producing and distributing new crop varieties that meet the needs of all farmers, in a cost-effective way. Farmer-based seed production and marketing was given priority in the approach so as to increase farmers' access to seed.

Definition of farmer-based seed production

The term 'farmer-based seed production and marketing' implies farmers' ownership of the enterprise, and their responsibility for independently operating it with commercial intent. In this section, however, farmer-based seed production is used more loosely to describe any form of seed production and supply conducted with or by farmers, with great differences in scope and ownership. Within the Ethiopian context, several approaches are used by stakeholders involving farmers in local seed production, including genetic resources conservation, crop improvement, variety popularization

and seed supply. These include local landrace seed production for distribution in drought-affected areas; landrace improvement, seed production and dissemination to repatriate farmer varieties; research-based seed production and dissemination to popularize released varieties; contractual seed production by the formal sector; and the establishment of local 'business oriented' seed enterprises managed by farmers/communities. To date, various initiatives with different names but similar approaches have been implemented by federal and regional organizations and donor agencies. The dissimilar names used are misleading and at times confusing because clarity on the role of implementing agencies and farmers' ownership of the operations is often lacking.*

Local landrace multiplication for drought prone areas

In the mid 1980s, a pilot project on Strategic Area Seed Reserves was initiated in response to recurrent droughts in the country. The project was initiated through a partnership of the ESE, the IBC, the MoARD and Oxfam, and implemented in selected areas in North Shoa and South Wollo zones. Local land races were identified, collected, characterized, multiplied and stored for distribution to farmers as seed relief in times of drought. The project evolved into a farmer-based germplasm conservation, enhancement, seed production and use programme.⁷ The project covered three areas: (i) on-farm improvement of landraces by mass selection; (ii) on-farm development and maintenance of elite landrace selections; and (iii) on-farm seed production and distribution.†

Farmer-Based Seed Production and Marketing Scheme

Within the context elaborated above, the government introduced a Farmer-Based Seed Production and Marketing Scheme (FBSPMS). It had two main objectives: (i) to produce seed of crops which are less mechanized and less profitable for seed production on state farms, and (ii) to produce and distribute seed within the farming community to avoid transporting it from distant regions.

First experiences with contract seed production

The ESE's contractual seed multiplication with large-scale state farms was effective because the state farms are well equipped with farm machinery and have skilled manpower. However, the state farms could not multiply all the crop varieties required by smallholder farmers due to the low level of mechanization of some of these crops. In the 1980s, the ESE started contractual seed multiplication with smallholder farmers through Producers' Cooperatives (PCs). Seed production with PCs was based on contractual agreements and quality assurance programmes. The contractual seed multiplication was easy to implement because PCs were legally organized and the

* Johannes Engels, Jean Marie Byakweli Vianney, Hannes Dempewolf and Walter de Boef place the array of initiatives mentioned within a broader context of robust seed systems in which ownership is mentioned as one of the key concepts (Section 1.6).

† See Section 3.4 by Girma Balcha and Tesema Tanto for similar in situ conservation, enhancement, seed production and/or utilization activities in selected areas of Ethiopia.

agreements were binding. PCs took full responsibility for honouring the contract for seed multiplied by members. PC members also merged their plots to form larger clusters, making seed multiplication easier. Harvested seed was stored at PC premises until seed sampling and testing were completed.

The seed produced was transported to ESE centres, cleaned, graded, packaged and sold to farmers and seed users throughout the country. The main crops handled were teff in the North West and durum wheat in the central parts of the country. Such activities were also favourable for smallholder farmers, who organized themselves into cooperatives since this assured easy access to improved crop varieties and free supplies of packaging materials from the ESE. The activity was discontinued in the early 1990s. Similarly, the national genebank also carried out some seed multiplication with smallholder farmers, to conserve local varieties.*

Early years of FBSPMS operation (1997-2001)

In 1997, the former National Seed Industry Agency (NSIA) started a nation-wide Farmer-Based Seed Production and Marketing Scheme (FBSPMS), implemented in collaboration with the Regional Agricultural Bureaus through a five-year technical assistance project financed by the World Bank. The objective was to organize and support groups of farmers in sustainable seed production and income generation by providing materials and inputs through a revolving fund, training of farmers and extension workers, and small-scale seed cleaning facilities. Production increased during the scheme's period of operation. Many farmers participated and the crops covered diversified (Table 1.9). The premium price offered for seed and the provision of packing materials, inputs and credits made it attractive for farmers to participate in seed multiplication. The scheme was carried out in seven regions (Amhara, Benshangul Gumuz, Gambella, Harari, Oromia, SNNPR, and Tigray).

The plan was to produce, process and market 144,000 tons of seeds of improved varieties during the fifth year, with 15,000 farmers involved. It strengthened the development of seed supply for self pollinated cereals in the country. The seeds produced were processed to commercially accepted standards and sold to nearby farmers. The FBSPMS provided training in seed production technology for development agents and supervisors (1800), seed quality control technicians (331), trainers (98), machinery operators (50), and – most significantly – farmer seed producers (31,000). Thirty mobile seed cleaning machines with an average capacity of 1.5 tons/hour were distributed to different regions over the project period. These machines were provided free of charge, with the exception of Oromia region, where the seed cleaners were administered by co-operatives at a minimal charge. In addition, threshers (40), shellers (19), double cabin pickups (7), and motorcycles (90) were provided to support the FBSPMS.⁸

* See also Section 3.4 by Girma Balcha and Tesema Tanto describing the role of community gene/seed banks contributing to the conservation of local crops and varieties.

Table 1.9 FBSPMS seed production under the NSIA (1998-2001)

<i>Crops</i>	<i>Years</i>				<i>Total</i>
	<i>1998</i>	<i>1999</i>	<i>2000</i>	<i>2001</i>	
	<i>Area (ha)</i>				
Cereals	735	2,687	6,853	7,976	20,081
Legumes	-	43	229	381	653
Oilseeds	-	-	10	67	77
Vegetables	2	17	95	30	143
Forages	5	22	13	-	40
Total	741	2,769	7,200	8,454	20,994
	<i>Production (tons)</i>				
Cereals	1,079	5,745	15,050	14,309	36,189
Legumes	-	26	244	417	687
Oilseeds	-	-	12	44	56
Vegetables	8	36	825	60	931
Forages	-	6	13	-	18
Total	1,087	5,812	16,144	14,830	37,872

Within the NSIA structure, seed marketing was the responsibility of the Regional Agricultural Bureaus (RABs, now BoARDs), farmers' cooperatives and commercial trading companies. The NSIA performance assessment report showed that a considerable proportion of seed produced (as much as 50%) was directly used as grain/food or sold in local markets.⁹ There were several constraints which included: (i) ineffective sales promotion and marketing; (ii) low seed price paid to farmers; (iii) few sales centres and no retailers; and (iv) low quality of seeds offered for sale. Although the report did not indicate the amount of RAB seed sales, it is assumed that some of the seed purchased was not sold and remained in store for years. The report also indicates that the role of RABs declined sharply: they purchased about 26% of the seed multiplied in 2001 (Table 1.10).

Table 1.10 FBSPMS - Analysis of production and use of seed produced (1998-2001)

<i>Year</i>	<i>Produced (tons)</i>	<i>Utilization (tons)</i>					<i>Sold in market</i>
		<i>Purchased by RABs</i>	<i>Farmers exchange</i>	<i>Seed saved</i>	<i>Used as seed (%)</i>	<i>Used as food</i>	
1998	92	40	16	5	66.3	13	18
1999	233	106	30	12	63.5	47	38
2000	456	208	62	23	64.2	90	73
2001	655	170	57	33	39.6	157	238
Total	1436	524	165	73	233.6	307	367

Note: based on a survey with a sample of 404 farmers conducted by the NSIA.

Current structure and organization

In 2002, the responsibility for the FBSPMS was officially transferred from the NSIA to the ESE. Similar schemes are being implemented in Amhara and Oromia regions (Figure 1.1) under the supervision of the Regional Bureaus of Agricultural and Rural Development (BoARDs). In general terms, the ESE and BoARD use the following approach in the execution of the scheme:

- *Pre-planning*: Seed production follows variety popularization and extension activities. The approach adopted includes: (i) variety demonstration and farmers' field days; (ii) evaluation of crop varieties distributed and/or demonstrated; and (iii) training seed users and information exchange. Smallholder farmers get opportunities to choose the variety they intend to multiply, which also encourages them to retain as much seed as possible after they produce them. This practice addresses the criticism that farmers have little choice in participation and decision making in the FBSPMS.¹⁰
- *Planning seed production*: This component is incorporated with the following considerations: (i) data from varietal demonstration plots, field days and information exchange forums; (ii) trends in varietal preference from past records of seed sales; and (iii) availability of seed (basic and/or certified seed) for further multiplication.
- *Selecting seed production sites*: Woredas are selected based on the availability of suitable land, willingness to undertake contract seed multiplication, accessibility by road and availability of storage facilities. The willingness of Woreda Agricultural and Rural Development (WoARD) Offices to assist in seed production activities is also considered. Farmers who could afford to buy inputs or who are eligible for credits to purchase inputs were selected for contract seed multiplication.
- *Seed multiplication contract*: The contract agreement is signed both by the ESE and individual farmers, stipulating their obligations. The ESE provides technical advice and supplies basic or certified seed for multiplication, as well as raw seed packaging materials. It is also responsible for procuring seed produced as long as it fulfils the standards agreed upon by both parties. Seed procurement prices are determined on the basis of a grain market survey conducted within a 25 km radius, usually between mid November to mid February on specific dates set jointly by the ESE, farmers and WoARD. A premium of 15% of the grain price based on the results of the survey is added to the seed price as an incentive.
- *Monitoring seed production*: Monitoring involves stakeholders such as the WoARD Offices, farmers' cooperatives and Development Agents (DAs) at village level. Involving WoARD is very important for the success of the scheme as it has a major developmental role.

Scheme operations in the regions

Initially, the NSIA implemented its FBSPMS through RABs. The Amhara and Oromia regional BoARDs continue their involvement in FBSPMS, following slightly different strategies and approaches in implementation. The scheme covers four zones and 20 woredas in Amhara region and seven zones and 34 woredas in Oromia region,

as shown in Figure 1.1. Below we describe the FBSMS in Amhara and Oromia, as executed through BoARDS, and those in other regions, executed by the ESE.*

Amhara Bureau of Agriculture and Rural Development

In 1997, a collaborative rural development programme was started by Amhara National Regional State (ANRS) in collaboration with the Swedish International Development Agency (SIDA), with the overall objective of establishing sustainable agricultural production to improve farmers' livelihoods through access to quality seed by: (i) strengthening the informal seed supply through establishment of a woreda (district)-based seed multiplication and supply scheme; (ii) stimulating the private sector to participate in seed production and marketing; and (iii) improving procedures and regional facilities for seed quality assurance. In its activities it includes the organization of woreda-based small-scale seed production, processing, storage, marketing, quality control and rural credit. From its start, the programme is business-oriented as it includes market research and the preparation of business plans for seed production, processing, storage and distribution. At present, the Amhara BoARD coordinates the scheme in collaboration with SIDA and the Organization for Rehabilitation and Development in Amhara region. The activities are located in 20 woredas in East Gojam (8), North Gondar (3), North Wollo (2) and South Wollo (7) zones, and though their coverage is not very wide, they do include both high and low potential areas (Figure 1.1). Amhara BoARD coordinates all technical matters while the role of the other two agencies is largely limited to financial support which covers training, seed purchase, and seed processing machines. The regional agricultural research institute and the regional cooperative promotion bureaus are partners in the scheme and supply basic seed and assist in identifying cooperatives for seed marketing, respectively.

The amount of seed produced fell far short of the huge demand as the amount of seed collected, processed and sold was very low (Table 1.11). The scheme had problems in raw seed purchases and clean seed sales. Farmers exchanged the seed produced on contract instead of returning it. The premiums paid were not attractive for farmers because market surveys to fix prices were conducted when grain prices were at their lowest in the season. Moreover, marketing was poorly organized and many cooperatives suffered losses from low seed sales and excessive carryover stock that could not be sold as seed. This forced many cooperatives to abandon seed sales and they almost stopped raw seed purchase in 2007. The scheme is now declining and the regional government preferred to opt to support FBSPMS operated by the ESE.

* Ibrahim Osman shares in Section 6.1 the structure for supporting community-based seed enterprises adopted by the FAO and its partners in Oromia region.

Figure 1.1 FBSPMS operational areas coordinated by Amhara BoARD and Oromia BoARD

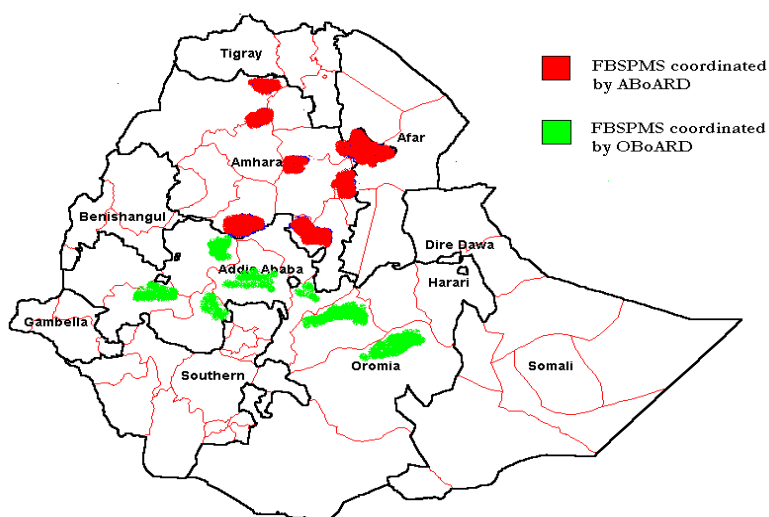

Table 1.11 FBSPMS seed production under BoARD in Amhara region (2004-2007)

Crop	Amount of seed (tons)				Total
	2004	2005	2006	2007	
Wheat	175	632	607	125	1,538
Teff	8	196	129	-	333
Barley	1	-	-	-	1
Faba bean	1	-	6	27	34
Chickpea	-	10	-	-	10
Haricot bean	-	-	57	15	72
Soybean	-	-	49	114	163
Ground nut	-	-	5	15	20
Total	185	838	853	296	2,171

Source: Amhara BoARD

Oromia Bureau of Agriculture and Rural Development

In 2003, Oromia BoARD started the FBSPMS to address existing seed shortages and meet the needs of an ambitious plan to double crop production in the region. Initially the bureau tried to implement the scheme extensively throughout the region. However, due to several technical and logistic problems it reduced the activities to potential areas from the third season of its operation. Since then the scheme was limited to eight zones and 34 woredas, which were identified as potentially surplus grain producing areas (Figure 1.1). This includes Arsi (7), Bale (4), East Shoa (5), North Shoa (6), West Shoa (5), South West Shoa (4) and Horoguduru Wollega (3).

The way the scheme was implemented in Oromia differed slightly from the way it was done in Amhara. Farmer Cooperative Unions (FCUs) provided basic/certified seed and other inputs on cash or credit directly to farmers. Field operations and quality assurance were monitored by a technical committee established at woreda level and including development agents (DAs). To a limited extent, the scheme also used the seed testing laboratories established by the NSIA at Ambo and Asela. However, the laboratories were few in number and were not well equipped with manpower and facilities. Therefore, Oromia BoARD tested only seed lots that were expected to have quality problems.

Seed purchasing and cleaning were entirely the responsibility of the unions using machines provided by the NSIA. Setting premiums was done quite differently from the approach in other similar schemes handled by the ESE or Amhara BoARD. Fixed premiums were paid over the grain prices at harvest time at the rate of 40 ETB/quintal for basic seed and 30 ETB/quintal for certified seed. The cooperatives already have experience of distributing seed from the ESE. The unions were responsible for seed sales and distribution, with assistance from Oromia BoARD. They distributed the seed they processed along with seed bought from the ESE. Any seed not used within the vicinity was sold to other parts of the Oromia region.

Table 1.12 Analysis of production and sales of seed produced by the FBSPMS under BoARD in Oromia region (2005-2006)

<i>Crop</i>	<i>2005</i>			<i>2006</i>		
	<i>Production (tons)</i>	<i>Sales (tons)</i>	<i>Efficiency %</i>	<i>Production (tons)</i>	<i>Sales (tons)</i>	<i>Efficiency %</i>
Wheat	13,344	3,314	24.8	11,990	1,342	11.2
Barely	3,227	894	27.7	2,354	102	4.3
Triticale	147	89	60.3	1,146	11	1.0
Teff	552	296	48.8	762	140	18.4
Maize	-	-	-	9	120	100
Sorghum	61	11	17.9	83	4	5.3
Millet	12	0	0	2	0	0
Faba bean	139	16	11.8	22	7	34.0
Field pea	28	11	37.6	83	21	25.1
Chickpea	1,145	625	54.6	2,242	88	3.9
Lentil	653	0	0	224	71	31.7
Haricot bean	499	0	0	254	0	0
Soybean	-	-	-	59	3	4.8
Ground nut	22	148	100	86	0	0
Linseed	15	7	45.7	5	0	0
Sesame	178	2	1.2	75	0	0
Rape seed	4	0	0	-	-	-
Potato	83	36	44.0	43	0	0
Vegetables	5	48	100	192	0	0
Total	20,113	5,466	27.2	19,631	1,909	9.7

Note: Vegetables are garlic, onion and pepper; Source: Oromia BoARD

In Oromia seed production was easier than it was in Amhara because the average plot area is larger, which enables many farmers to participate in the scheme. However, as in the case of the NSIA and Amhara BoARD, seed marketing was weak and the amount of clean seed sold was very low, and also declined in 2005 and 2006 (Table 1.12). However, the Oromia region continued with the scheme in the face of several problems that remain unresolved.

Ethiopian Seed Enterprise in Amhara, Oromia, SNNPR and Tigray

In 2002, the ESE took responsibility for the scheme, which was treated as a formal sector operation. A tremendous effort was made, especially to upgrade the quality of the seed produced through the scheme to meet national standards. The ESE introduced a flexible pricing policy in which a 15% premium was paid on the current grain price. The ESE also supplied basic seed at lower prices and allowed farmers to keep 10% of the seed produced for planting next season. The ESE collected seed either directly from farmer premises or from nearby villages using its own transport. Some seed was cleaned using mobile machines and distributed back to other farmers in the area where it was produced. However, most of the seed was transported to the ESE regional centres for processing and sale elsewhere. The number of participating farmers increased over the years from 695 in 2002 to 2,541 in 2003 and 6,679 in 2004. In 2006, the share of seed produced by the farmer based production programme reached about 35% of the total certified seed production by the ESE (Table 1.13).

Table 1.13 ESE FBSPMS seed production (2002 - 2006)

Region	2002		2003		2004	
	Area (ha)	Production (tons)	Area (ha)	Production (tons)	Area (ha)	Production (tons)
Amhara	73	111	317	576	1,639	1,558
Oromia	124	172	557	1,160	1,459	1,399
SNNPR	46	80	125	157	1,349	1,283
Tigray	20	33	265	411	727	691
Total	263	3,96	1,264	2,304	5,174	4,932

Region	2005		2006	
	Area (ha)	Production (tons)	Area (ha)	Production (tons)
Amhara	559	1,118	890	2,119
Oromia	1,221	2,258	1,330	1,855
SNNPR	611	1,005	622	1,176
Tigray	1,709	2,027	1,565	2,544
Total	4,100	6,408	4,407	7,694

Note: SNNPR = South Nations, Nationalities and Peoples Region;
Source: ESE annual reports

Seed marketing was the major challenge for the NSIA and it continues to be so for the ESE. Under the NSIA, the RABs were unwilling to purchase seed for marketing. In the case of the ESE, farmers refused to sell back the seed multiplied, partly due to confidence and demand for quality seed produced under ESE supervision. At least, the ESE was better placed for marketing than the RABs since it could sell the seed produced irrespective of where it had been multiplied, whereas RABs were obliged to sell the seed within the area of multiplication. Farmers showed little interest in buying seed multiplied within their vicinities because they could get the same seed from fellow farmers through informal exchange or local purchase. Clearly, the farmers' informal seed exchange system should be taken into account when marketing seed within farming communities.

Achievements and constraints

Despite many difficulties, the FBSPMS has accomplished several achievements: (i) the creation of awareness of the importance of improved varieties and seeds among stakeholders; (ii) the fast introduction, adoption and diffusion of new crop varieties; (iii) the increased availability, access and use of seeds; and (iv) the transfer of relevant knowledge about seed production to farming communities. The ESE has specifically addressed the issue of seed quality; as a result many farmers have improved their seed production and storage practices, which also contribute to quality grain production. The main achievement of the FBSPMS handled by the ESE can be considered the fast introduction of improved varieties and knowledge about seed handling to different farming communities. However, there are also critical technical, administrative and policy problems. We describe briefly the major concerns currently faced implementing the FBSPMS.

Farm sizes and locations

Seed production in a more formal setting such as FBSPMS requires larger plots planted with similar crops and varieties. Farmers usually have small fragmented landholdings and plant diverse crops and varieties. Clustering fragmented small plots was difficult. Due to land scarcity, most farmers were reluctant to maintain the required isolation distances, causing problems of variety contamination.

Poor accessibility and communication

Seed production requires continuous monitoring, particularly when it is done by smallholder farmers with limited experience. In most areas, poor road infrastructure hindered close supervision and frequent communication with farmers. Seed fields were not verified and the seed produced was not certified due to the limited capacity of the certifying agency. Thus the ESE took sole responsibility for quality assurance, which demanded a lot of resources.

Maintaining cropping history

To avoid mechanical admixture, farmers were advised to keep proper records of the cropping history of their fields. Unfortunately, most farmers did not do this properly

because of land fragmentation and multiple cropping systems. Roguing was not carried out either, because farmers were afraid of possible crop damage.

Use of high seed rates

During planting, farmers used higher seed rates to compensate for poor land preparation and seed loss. Lower plant densities were expected, especially in seed multiplication plots of modern varieties due to low emergence if seed is planted deep in the soil. Farmers tended to overplant the production fields with their own seed, which caused problematic admixtures.

Seed quality assurance

Quality assurance of seed produced by the FBSPMS is an important issue. The Agricultural Inputs Quality Control Department of the MoARD is responsible for official seed certification. The department is not well equipped with manpower and facilities for inspecting the FBSPMS fields. In view of the poor rural infrastructure and weak certification scheme, it is not feasible to conduct official inspections of numerous fragmented seed fields within the framework of the formal seed system. The ESE therefore sampled and tested the seed produced before procurement. Since there were large numbers of seed lots harvested from many different plots, this was a lot of work and, besides requiring temporary storage space, it took a lot of time and delayed procurement (Table 1.14). The delays in seed testing combined with grain price fluctuations meant repeated market surveys to set the premium price. Physical purity tests have not yet been standardized and testing was only done by visual examination by field inspectors.

Table 1.14 Sampling intensity of seed produced by the FBSPMS (Bahr Dar Center, 2005)

<i>Crop</i>	<i>Quantity of seed (tons)</i>	<i>Number of samples</i>	<i>Sampling intensity (quintal/sample)</i>	<i>ISTA maximum lot size (tons)</i>
Wheat	299	121	25	25
Teff	2	7	3	10
Faba bean	7	10	7	40
Sesame	80	20	40	10

Note: 1 quintal = 100 kg;

Source: Bahr Dar Regional Center, ESE unpublished annual report, 2005.

Low seed procurement

The ESE annual reports (2003-2006) show that only 46% of seed produced was procured, largely because farmers were not willing to sell back the seed multiplied on contract (Table 1.15). Instead, farmers exchanged, sold or gave seed to fellow farmers for planting purposes. This seriously disrupted the ESE's production plans.

Table 1.15 Analysis of seed production and purchase from the FBSPMS by the ESE (2003–2005)

<i>Year</i>	<i>Raw seed produced (tons)</i>	<i>Raw seed for sale to ESE* (tons)</i>	<i>Raw seed purchased by ESE (tons)</i>	<i>% purchased by ESE</i>
2003	2,304	2,074	1,071	51.6
2004	4,932	4,439	2,386	53.8
2005	6,408	5,767	2,269	39.3
2006	7,694	6,925	3,089	44.6
Total	21,338	19,205	8,815	45.9

Note: *Amount of seed available after 10% retention by farmers;
Source: ESE, unpublished report.

Dispute settlement

The ESE and farmers signed agreements to facilitate smooth operation. However, the agreements were considered non-binding, especially by the farmers. WoARD and woreda administrators arbitrated in cases of disputes. None of the disputes have been resolved through such arbitration.

Competition between seed and grain sales

Since the contract agreement was non-binding, farmers were tempted to sell the seed they produce to a third party offering a higher price than the market price at harvest time. Grain merchants, grain exporters and flour mills competed for grain markets and disrupted the seed production scheme.

Policy issues

When the Ethiopian Seed Proclamation 206/2000 was enacted, the FBSPMS had already been operational for two years, without any binding agreements between implementing agencies and participating farmers. However, the proclamation required that any seed lot for sale should conform to national seed quality standards. The ESE considered the FBSPMS as formal sector operations; the seed produced should meet the quality standards set by the proclamation. Nevertheless, it proved difficult to realize the requirements and the law was not amended to include the FBSPMS.

Sustainability of the scheme and emerging issues

In the previous paragraph, a number of the most critical problems encountered have been presented and discussed. The sustainability of the FBSPMS as an intervention, particularly regarding subsidies, profitability, seed quality and market is an important issue. In the ESE's operation of the scheme, farmer-based seed production can be considered part of the formal system but it is facing difficulties as such.

One modification was the introduction of flexible premium payments for the raw seed. ESE used to add 15% of premium price on the current grain price when buying raw seed from contract seed growing farmers. It also supplied basic seed for multiplication at prices of certified seed and allowed the seed multipliers to keep 10% of the seed they produced for the next season or to exchange with other farmers, in

an effort to help the informal diffusion of improved varieties and seeds within the locality. ESE used to collect the seed from the farmers' providing transport free of charge. After processing, the seed was distributed at a reasonable price back to other farmers in the areas where it was originally produced.

In the 2004 crop season, there was a sharp increase both in seed production area and the amount of seed produced (Table 1.13). The number of participating farmers in the seed production increased from 695 farmers in 2002 to 6,679 farmers in 2004.¹ In 2005, the share of the seed produced by the FBSPMS was about 25% of the total certified seed production by the ESE.

The FBSPMS was coordinated by different organizations without due consideration for practical implementation methods. This resulted in several problems when the scheme became operational. For example, the ESE considered it as a formal sector operation whereas others considered it as a semi-formal or informal sector scheme. The most important step towards strengthening the long-term viability and performance of the scheme would be to create a framework for its operation. In particular, this would resolve the issue of the legal basis for quality assurance.

Seed marketing posed a critical problem which was due to the nature of the scheme itself. For example, the scheme produced, processed and sold the seed within the same locality where farmers usually had back door access to the same seed through exchange or gifts from fellow farmers who grew it on contract. Though differences in this modality exist among regions, in reality all farmer-based seed production operations are nothing more than contractual seed production with farmer groups. A clear strategy needs to be developed to address seed marketing and promotion in order to make the operation viable and sustainable.

Past experiences of the ESE showed that the scheme was legally deficient in terms of seed quality assurance issues. The scheme did not fit into the existing policy and regulatory framework. Many seed quality concerns were not addressed when the system was applied. The ESE tried to apply quality assurance measures to seed produced by small farmers, though the practice was costly and inefficient. It may be necessary to lower the standards for seed produced by the FBSPMS.*

The FBSPMS should continue to address the seed requirements of smallholder farmers. Seed enterprises may deal with small farmers who own relatively larger plots, so as to facilitate seed multiplication. The recent upsurge of willingness on the part of small-scale farmers to offer their small plots for clustering into larger plots for seed multiplication in Amhara region is an excellent opportunity to solve many problems associated with small and fragmented seed multiplication plots. This development is also expected to help with organizing farmers into seed producer groups, which could eventually develop into village-based small-scale seed enterprises. Farmers in other regions should be encouraged to do the same. It is also advisable to follow the strategy of Oromia BoARD in selecting zones and woredas that are potentially fertile and suitable for seed multiplication, in order to meet the large seed demand in the country.

* In Section 7.5 Walter de Boef and Anthony van Gastel report how a broad range of stakeholders and policy makers address this issue of quality assurance supporting farmer-based seed supply and small scale/community seed enterprises through relaxing frameworks.

Given the constraints listed above, it becomes imperative to seek alternative ways of organizing the scheme to make it viable and sustainable. It is critical to transform the scheme so that it is entirely operated and managed by the farmers themselves, whereas the role of governmental and non-governmental organizations should be limited to helping farmers to organize themselves to form locally operated independent small-scale seed enterprises.* It should be treated as a scheme that could fill the gap in seed demand and complement both the formal and the informal systems. FAO's approach of Cooperative Community-Based Seed Enterprises (CCBSE) may be helpful in this organizational process; a step towards this approach would be to restructure the FBSPMS so that it becomes more business-oriented and community based.† CBSPM could also be a useful approach to meeting the need for improved seed through linkages with the formal system. First, it motivates farmers to organize themselves as a group for sustainable production and income generation. Secondly, it assists in building regional seed supply capacity by producing and distributing the required varieties to farmers in good time and at affordable prices. And thirdly, it encourages and creates a basis for private investors to enter into the seed business, thus transforming the community-based groups into community-based enterprises.

It is also necessary to share experiences among the different organizations which dealt with the issue of making sustainable seed available to the vast majority of smallholder farmers. Moreover, almost all stakeholders in the FBSPMS incorporated the decisive role of farmers' cooperatives into key operations such as seed processing and marketing. Many of the cooperatives and their unions were still too young to shoulder such major responsibilities. More emphasis should be laid on organizing specialized seed marketing cooperatives, which could be used as transitional organizations in the development of farmers' small-scale seed enterprises.

1.3 A system perspective for linking farmers and professionals supporting farmers practices in seed supply

Walter S. de Boef and Zewdie Bishaw

Crop improvement, from traditional plant selection by farmers to conventional plant breeding by professional breeders, has always played a central role in agricultural development. However, it is widely recognised that modern crop improvement in recent decades has brought both successes and failures. Improved varieties of the

* Various sections in Chapter 5 elaborate mechanisms for setting up and sharing experiences of working with community-based or small-scale seed enterprises.

† Ibrahim Osman and colleagues share in Section 6.1 the structure for supporting community based seed enterprises adopted by the FAO and its partners in Oromia.

major food crops have been particularly successful in the more favourable and uniform agricultural areas, for example in the irrigated rice systems in Asia. In these areas, farmers replaced their local varieties with a few genetically uniform improved varieties. When adopting improved varieties they also increased the application of chemical inputs. The combination of a reduced crop genetic diversity coupled with increased application of fertilizers and chemical crop protection has made these systems vulnerable and in many cases unsustainable.

In the less favourable marginal and heterogeneous areas, farmers manage an important assortment of crops and varieties. In some areas, farmers adopted improved varieties for one or more crops to partially replace local varieties – sometimes even increasing the number of varieties grown. In other areas, particularly the most marginal and heterogeneous ones, improved varieties have not brought any significant gain at all. So far, farmers in these environments have hardly benefited from agricultural development.

At the same time, the global political and legislative framework is increasingly obstructing the free availability, access to and use of genetic diversity, and farmers' and communities' practices in the management and use of this diversity. The interests behind the developments of biotechnology, patenting, and commercialization of genetic resources are different from those that aim at the local development of farmers and communities.

Pioneering farmers, researchers and development workers are looking for alternative methods of crop improvement and seed supply that restore diversity in the farming systems. They aim to reduce vulnerability against pests and diseases, to reduce excessive use of polluting inputs, to ensure sustainable production to meet multiple uses of the household, and to keep options open for unexpected environmental changes and market demands.

This section presents a system perspective that helps us to understand the complex institutional and practical relations between organizations and professionals within the agricultural research and development system, and farmers and their communities in crop development. We take this general perspective, in which seed supply is one of the components of this research and development system, and part of farmers' management of crop diversity.

The informal and formal systems

In the figure below we illustrate the use and management of crops, varieties and seeds (Fig. 1.2). We use a model in which the starting point is the farmers' system, often referred to as the 'informal seed system'. We distinguish this from what takes place within 'institutionalized' research and development system, which we describe as the 'formal seed system'. The two-system model is a simplification of reality, which is much more complex in actual practice. The system varies in space (spatial) and over time (temporal) based on agro-ecology, farming systems, crops, varieties and seeds. It can even vary for instance between the rich and poor farmers in a community, or between different crops within a household, for example where maize may be part of the formal system whereas pulses are primarily part of the informal system.

The complex nature of reality is the reason why we use a model to identify opportunities, organizations and professionals in the formal seed system to enhance farmers' practices and management within the informal system, or where farmers can use their skills and practices to enhance the performance and impact on agricultural development of the formal seed system. In others words, we use the model to identify opportunities for participatory approaches to crop improvement and seed supply.

The informal seed system

Farmers have always been - and still are - the principal managers of agrobiodiversity, crops, varieties and seeds. Farmers select crops (usually a diversity of species), varieties (a diversity of genetic variation within species) and seeds (diversity within a variety) for planting or replanting (Fig. 1.2).

Fig. 1.2 Formal and informal system of management of plant genetic resources or seed

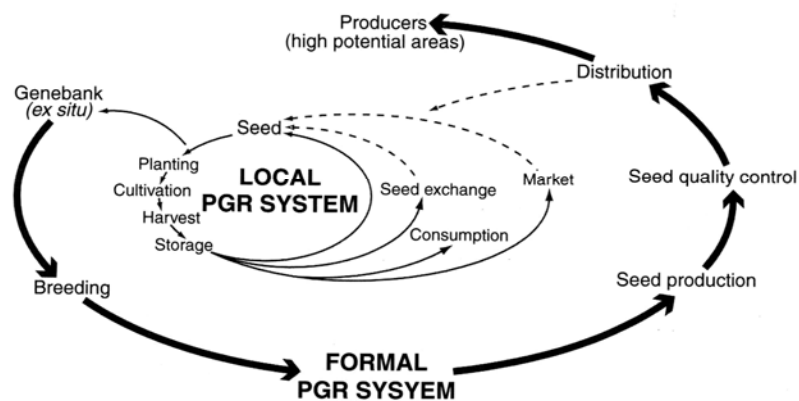

Farmers produce their own seeds, are involved in crop improvement (selection of varieties and seeds) and maintain genetic diversity. In other words, they manage the plant genetic resources in an integrated way and for different purposes. Farmers' selection, in combination with natural processes such as genetic mutations, crossing between varieties and wild relatives and the influence of the natural environment, form a system of continuous crop evolution. The system has resulted in domesticated and cultivated varieties of a wide range of crop species. The local system is based within one farm or community, but through exchange of seed of different varieties, its scale can range in kilometres across national borders or natural barriers. However, by its very nature the main level of operation is at the community level.

The formal seed system

The institutions involved in the conservation of genetic resources (genebanks), improvement (breeding programmes) and seed supply (seed programmes) together form a formal seed system that runs parallel to the informal system (Fig. 1.2). The formal seed system evolved following the rediscovery of 'genes' and 'genetics' and

with the increase in knowledge about manipulating the characters of plants through selection and crossing. Breeding became a specialized activity, taking place in research stations and carried out by breeders/researchers. Genebanks were set up as institutions to collect and maintain genetic resources to readily supply them to breeders. Seed programmes were designed to enhance the adoption and diffusion of breeders' varieties to the farmers in the form of quality seed. This led to the development of a chain-wise operation and vertically organized institutional system, which had clear mandates and was less integrated than the informal system. This system successfully supported agricultural development in Europe and Northern America, where uniformity is promoted at the expense of diversity and conservation. The same model was used as a 'blueprint' for agricultural development in the South. In this 'blueprint' the role of farmers in crop improvement, seed production and conservation is totally ignored. Through access to a global pool of germplasm and improved materials by breeders, the formal sector became dominant over the informal system, operating at more regional and national levels, and increasingly at a global level.

The mismatch

The informal and formal seed systems can be considered as two parallel, but separately operating systems. Actually, there are at least two nodes of contact between the two systems. The first point of contact is through the collection missions organized by genebanks to those areas where farmers are still growing many traditional varieties and/or to areas rich in wild relatives. The second point of contact is the distribution of seed of improved varieties by the institutional system to the farmers.

The conventional mandate of seed programmes is to supply seeds of improved varieties, i.e. the products of the breeding programmes. However, as mentioned earlier, the institutional system has not been very effective where the agro-ecological environment is more variable, and the needs and preferences of farmers more diverse. First, these improved varieties were often unattractive for farmers because of the mismatch between breeding programmes and the farmers' diverse needs. This was reflected in farmers' perception of the varieties: In some situations they were only acceptable when accompanied by subsidized inputs. Second, the conventional seed programmes were also handicapped by the often good quality seed produced and saved by and exchanged among farmers. Most farmers do not have incentives to buy new seeds, unless they have lost their seed, want to try new varieties, grow hybrids or vegetables. Particularly with regard to self-pollinating and vegetatively propagated crops, seed programmes have over-estimated farmers' interest in regularly purchasing commercial seed. Third, the remoteness of the agricultural production areas further increased the difficulties for seed supply from the institutional sector. Given these constraints, it is not surprising that seed programmes, which were copies of the 'western blueprint', were usually only successful when targeting favourable environments and commercial crops, but were ineffective when targeting less favourable environments and subsistence food crops.

Conservation versus development?

The value of conserving the genetic diversity that is still cultivated in the traditional systems is undisputed. It is becoming increasingly clear that farmers will always have a need for genetic diversity in order to cope with environmental variations, changing market conditions and to keep future options open - both in high and low potential areas. The challenge is to combine development with maintenance of genetic diversity. The Green Revolution introduced improved varieties which replaced a wide range of local materials, often reducing the number of varieties planted. For most breeders this is an accepted 'trade-off'. Selection of the best variety leads to the elimination of several others that perform less well. The selection of the best genotype in a variety (or elimination of the undesirable ones) reduces genetic diversity in a landrace. Because of this, many consider that the maintenance of genetic diversity cannot be combined with crop improvement. The reality may be different, however. Particularly in environments where conditions vary within a field, from field to field or over the seasons, the genotype or variety that performs best may not be the same one in all situations.

Uniformity versus diversity

Farmers' varietal choice is influenced by ecological (adaptation), economic (marketing) and cultural (local use) factors. Perceptions and preferences of varieties differ between commercial and subsistence farmers. The former are more likely to prefer varieties with higher yields and productivity whereas the latter may prefer diverse varieties with more stable yields and multiple uses. In situations where commercial agriculture predominates and farmers are linked to markets, they are much more inclined to increase production and productivity by intensifying agriculture through using purchased inputs like fertilizers, pesticides, etc to maximize profitability. Moreover, the mechanization, intensification and commercialization of agriculture require uniform varieties for farm operation and industrial processing. Similarly, with a view to economies of scale, seed programmes also prefer few varieties with wider adaptability and high demand over many varieties with limited markets. Therefore, in commercial agriculture the potential yield and industrial quality are the criteria for choosing varieties for production.

In contrast, subsistence farmers practise complex patterns of farming which may involve the cultivation of many crops and varieties on the available land, with the primary objective of meeting household food requirements throughout the year while still having some marketable surplus, if possible, to meet additional expenditures. The main aim is to maximize the use of land and available resources for better returns and security, and to minimize the risks associated with farming. The diversification of crops and varieties is the main way in which farmers attempt to stabilize their production and income. Small farmers' perception of varieties is different from that of many plant breeders and commercial farmers. Besides yield, factors like grain quality for local food/beverages, storability, suitability for intercropping and the use and value of crop residues may all influence farmers' varietal choices.¹¹ Small farmers perceive that local landraces are more adaptable to their agro-ecology, give stable

yields and good grain quality, perform better under low input and poor soil conditions, and are suitable for the preparation of traditional foods.²

Commercial farming, then, relies on a few varieties and promotes uniformity and productivity at the expense of conservation. Traditional farming, on the other hand, depends on and promotes diversity, in order to minimize risks.

Both systems have their proper functions

A closer analysis of the informal and the formal seed system make clear that both have their weaknesses and strengths. Actually, they are complementary. The formal system has plenty of opportunities to support the informal seed system.¹² But history teaches us that this support is not effective if it is offered as standard packages and not adapted to the location-specific conditions and preferences. Contributions in this issue show the potential of decentralized approaches, building on participation of farmers and NGOs.

Support to farmers' practices and management

Better linkages between informal and formal systems offer many opportunities to combine the strengths of both. Several examples show that such linkages increase the availability of and access to seeds which provide farmers with adequate crop genetic diversity. Such activities also increase the effectiveness of the formal system since they lead to more adequately addressing farmers' needs.

Use of seed that is produced on farm or obtained from relatives, friends or other informal channels is still by far the most important seed source for agriculture in developing countries, and is still important in more industrialized agricultural countries as well. Eighty percent of all seed in developing countries is estimated to be on farm produced seed. Of course, the percentage varies widely between crops. It tends for instance to be high in wheat, a self-pollinating crop of which the seed stores relatively well. In crops like beans or groundnut, percentages are much lower, due to limitations of plant diseases and local storage facilities. In maize, a cross-pollinating crop, it depends very much on the availability and adoption of hybrid or improved open pollinated varieties.

Although the majority of seed for planting comes from farm-saved or locally exchanged seed, there is very limited knowledge on the effect of local storage conditions and management on seed quality. Understanding these limitations would help us formulate better solutions, by for instance aiming at improved storage practices or seed health management practices.*

Another important area of support relates to variety maintenance, i.e. seed production and selection practices that aim to maintain the variety characteristics and genetic potential through positive and negative mass selection.[†] Such support activities are particularly useful for landraces: seed from these varieties is usually not available

* In Section 2.1 Conny Almekinders and Niels P. Louwaars address farmers' capacities and skills in maintaining and selecting varieties.

† In Section 2.2 Niels P. Louwaars and Conny Almekinders address ways to support farmers producing quality seeds.

from formal sources and quite often mass selection can improve yields from landraces. For example, in Ethiopia an average yield increase of 5% per year through mass selection by farmers has been reported.¹³

Another important element of the local system is the seed exchange among farmers. Seed exchange and spontaneous crossings between varieties and between cultivated relatives and wild progenitors are important mechanisms that ‘feed’ the local pool of genes with new materials and characteristics, and keep it dynamic and diverse. In the Andes, seed fairs are traditionally important events for facilitating this seed exchange among farmers and communities. This is an example of a local mechanism ensuring access to a diversity of seeds and varieties.*

The original development of landraces from wild species by farmers’ selection, also referred to as crop domestication, illustrates that local crop improvement is an effective system of variety development. However, the weakness of informal systems is also apparent in their geographical isolation. Even though practices in seed management are illustrated widely, the genetic significance of seed management practices in terms of varietal identity and patterns of genetic diversity found in local varieties can not be easily proven. A study in many countries covering multiple crops systems could not prove such direct relations between seed systems and crop diversity in agro-ecosystem.¹⁴ The informal seed system is a dynamic system, with important genetic variation within and between landraces; it is also a system in which the introduction of new exotic materials or genes is usually restricted. In fact, for such introductions, it primarily relies on linkages with the formal seed system, for example for the introduction of resistance genes that are not available in the local gene pool. But, as Ceccarelli and Grando¹⁵ note, the introduction of varieties bred by breeders into a centralized breeding system does not give optimal results. Participatory approaches to crop improvement are promising alternatives which combine the farmers’ knowledge and capacity with the breeders’ expertise and access to materials.† The expectation is that if a variety of choices is offered to farmers, then different selections will be made by different farmers in different environments.

The challenge for the conservation of crop genetic diversity

Opportunities exist to support the agricultural development of small-scale farming, without eradicating the diversity that farmers have, and which they apparently need. Farming households need genetic diversity for a range of reasons: to meet their consumption and marketing needs; to cope with climate change, modifications in soil health and market changes; and to keep their options open. With increased market integration, small-scale farmers tend to specialize and practise less crop diversity. Simultaneously, cultural traditions erode. Since many cultural traditions are related to a rich use of biodiversity, support to the maintenance of local knowledge and cultural heritage can offer important opportunities for the sustainable management of genetic and other resources.

* In Section 3.7 Bhuwon Sthapit and colleagues elaborate practices including seed fairs supporting community biodiversity management.

† See various sections in Chapter 4 addressing participatory crop improvement.

Activities such as the organization of local seed banks support and improve the farmers' access to a diversity of seeds.* Seed fairs play a similar role: they enable farmers to find seeds that they may have lost through crop failure or otherwise.† These activities contribute to the in situ maintenance of genetic diversity or community agrobiodiversity management‡ by addressing seed security. Participatory crop improvement also contributes to the maintenance of genetic diversity, as well as to community or farmer management of agrobiodiversity. At the same time, these activities support rural and community development.

The outstanding challenge is to move from a situation characterized by innovative, but relatively isolated project activities by professionals and farmers to a situation in which these approaches are upscaled and become 'formalized' practice in national and international formal and informal institutions. This is not an easy challenge and requires above all flexibility and willingness on the part of professionals in the government agencies and NGOs to collaborate with farmers and other institutional actors. Policy and regulatory frameworks that by their very nature exclusively target the formal system need to be reviewed and rationalized so that they become frameworks that enable rather than impede the support of informal seed systems.

1.4 Participatory and learning-oriented approaches[§]

*Walter S. de Boef, Marja H. Thijssen, Cecile Kusters and
Karèn S. Verhoosel*

In the area of seed sector development, challenges exist that cannot be dealt with by carrying out the more formal types of research, in which professionals develop the research agenda and are primarily responsible for research implementation. Complex problems that formal research cannot solve alone and that require input from various stakeholders (e.g. government, NGOs, private sector, civil society) demand a more participatory and learning-oriented approach to the design and implementation of the research strategy. Stimulating the participation of the relevant stakeholders in the

* In Section 2.4 Pitamber Shrestha and colleagues describe their experiences working with community seed banks in Nepal.

† In Section 3.7 Bhuwon Sthapit and colleagues elaborate practices supporting community biodiversity management.

‡ In Section 3.6 Bhuwon Sthapit and colleagues elaborate community biodiversity management as a conservation strategy.

§ This section is adapted from the introductory section in De Boef, W.S. and M.H. Thijssen, 2007: Participatory tools working with crops, varieties and seeds. A guide for professionals applying participatory approaches in agrobiodiversity management, plant breeding and seed sector development. Wageningen, Wageningen International.

different stages of research will result in more relevant, effective and sustainable impact to the challenges that will be addressed. There should be participation from the start, when the problem is defined, and right through the implementation. There should also be continuous monitoring and evaluation of the participatory process: this is the key to facilitating community and multi-stakeholder learning.

This section provides a brief background sketch of participatory and learning-orientated approaches to diagnosis and research, as well as some background to the implementation of projects in the area of supporting informal seed supply. The section provides a framework in which tools for conducting a participatory diagnosis can be applied. We would like to emphasize that “participation is not just a matter of applying participatory tools but goes with a change in attitude that is truly participatory”. A vision of the kind of change one wants to achieve through the participatory process is crucial. It can ensure that participatory processes do not result in just technical solutions; the factor of social learning – farmers’, communities’ and/or stakeholders’ ability to solve shared problems – becomes the main result. Without this focus on social learning, the application of participatory tools can have adverse effects that may be difficult to adjust.

In this section, we discuss what we mean by participation. This is based on our own experiences as trainers and facilitators, complemented by the ideas of innovators who have inspired us and many others to create participatory learning and action environments that facilitate an impact-orientated research approach to empowerment and development. We elaborate how concepts of participation have developed over time, outline some underlying principles and offer some guidelines on how participatory learning and change processes can be facilitated.

Participation – background

Participation is about empowerment.¹⁶ In the late 1970s and 1980s, development organizations began realising the problems of non-adoption or limited impact caused by top-down and linear development approaches. Since the early 1990s, donor and development agencies have put their weight behind the promotion of participatory development. “Participation includes people’s involvement in decision-making processes, in implementing programmes, their sharing in the benefits of development programmes and their involvement in efforts to evaluate such programmes”.¹⁷

Participation can serve two broad purposes. Firstly, participation can be considered an instrument, i.e. a process by which development initiatives can be more effectively implemented. Participatory methods and tools can be used to incorporate people’s ideas in the development plans, and development or research activities. Secondly, participation can be considered a goal in itself, i.e. empowering the people by helping them to acquire skills, knowledge and experience to take greater responsibility (ownership) for their development.

Many arguments exist that support the use of participatory and learning-orientated approaches, while others highlight their shortcomings.¹⁸ Arguments in favour draw attention to outputs such as empowerment of the disadvantaged. When they recognize local knowledge in addressing local problems, development interventions and research processes may become more effective. Communities and stakeholders

become the focus of development and research processes, and responsibilities are delegated. This may increase the target group's ownership of the research and development processes, increasing the sustainability and impact of activities. Emphasizing stratified actions, thus targeting specific groups, may improve the status of disadvantaged groups such as indigenous people, women and the elderly.

Frequently mentioned shortcomings of participatory research and development processes include the fact that they take up a lot of time – for both professionals and rural people – and require large financial investments. In situations of poverty, participation can be perceived as a luxury and only emerges upon securing poor peoples' livelihood. If they are not properly embedded, participatory processes may unbalance existing social, political and cultural relationships within communities and among stakeholders. They are perceived to be driven by “ideological eagerness” and less concerned with securing direct benefits for poor people. Lastly, some consider them to shift the burden of driving the development process onto the poor or disadvantaged and onto local governments. Reflecting upon these pros and cons, it is essential to place the participatory processes within the wider socio-economic and political context. If we do this, we will surely obtain a differentiated picture of the goals and outcomes of participatory processes in different contexts.

When we analyse the division of roles and responsibilities among rural people and professionals we can distinguish different degrees of participation within participatory research and development processes. Such analysis provides a more comprehensible perspective, and also reflects the power relations involved in decision making on for example the direction of the development and research process, its implementation, and the allocation of available resources (human, physical, biological and/or financial). Table 1.16 describes seven types of participation.

Table 1.16 Typology of participation^{19,20}

<i>Typology</i>	<i>Components of each type</i>
A Passive participation	People participate by being told what is going to happen or what has already happened. People's responses are not taken into account. Shared information belongs to external professionals.
B Participation resulting in information transfer	People participate by answering questions posed by extractive researchers and conservationists using questionnaire surveys or similar approaches, for example to identify selection criteria for plant breeding. People do not have an opportunity to influence proceedings, as findings, research or project design are neither shared nor checked for accuracy.
C Participation by consultation	People participate by being consulted and external agents listen to views, for example to identify breeding objectives and variety recommendation domains. External agents define both problems and solutions, and may modify these in the light of people's responses. Such a consultative process does not concede any share in decision-making and professionals are under no obligation to take on board people's views.

<i>Typology</i>	<i>Components of each type</i>
D Participation for material incentives	People participate by providing resources, for example labour or land, in return for food, cash or other material incentives (seeds, fertilizers). Much on-farm testing and maintenance of varieties or accessions fall into this category as rural people provide the resources but are not involved in experimentation.
E Functional participation	People participate by forming groups to meet predetermined objectives related to the project, which may involve the development or promotion of externally initiated organizations. Such involvement is not observed during the early stages of project cycles or planning, but rather after major decisions have been taken. These institutions tend to rely on external initiators and facilitators, but may become self-dependent.
F Interactive participation	People participate in joint analysis, which leads to action plans, formulation of new local groups or strengthening of existing ones. Researchers use interdisciplinary methodologies that seek multiple perspectives and make use of systematic and learning processes. Learning groups take control over local decisions, and in this way people have a stake in the maintenance and further evolution of jointly created structures and practices.
G Self-mobilization	People participate by taking initiatives to change systems independently of external institutions. Such self-initiated mobilization and collective action may or may not challenge inequitable distribution of wealth and power.

Participation – multi-stakeholder setting

When participation is practised in research activities, local people should not be considered the only beneficiaries; other parties that may play a significant role in implementing the ideas from research may benefit too. These stakeholders may include extension services, NGOs, the business sector and even policy makers. It is important to consider which of the stakeholders to involve during the consecutive steps of the participatory process: (i) setting the research agenda; (ii) carrying out the diagnosis and research; (iii) deciding on research and development options; (iv) implementing and learning applying these options; (v) continuously monitoring and evaluating the impact of these options and the development process on the original setting and the people's livelihood.

In order to increase the impact, one needs to understand which stakeholder to involve at what point in the chain of events constituting the participatory process. Within such a multi-stakeholder setting, the process goes beyond peoples' (e.g. farmers') participation at local level, and a multi-stakeholder process (MSP) emerges. The design of MSPs needs to be well-structured and facilitated. Guiding questions become: "Who plays what role and why? What is the common goal and what individual gains can be made in the process?" A practical tool supporting MSP is a stakeholder analysis. This helps us answer questions such as: "What are the characteristics of stakeholders? What types of problems do they face in e.g. service

delivery? What can they offer to the project? What do they want to gain from it? And what are relations among the stakeholders like?” Insight into the possible stakeholder contributions and commitments to a participatory process creates the transparency needed for the conceptualization of a project. This process involves a diversity of stakeholders and requires facilitation that deals with complex relationships and structures of power. The key to effective facilitation is to create an atmosphere in which stakeholders are able and willing to join forces to create a shared learning environment. The facilitator plays a crucial role in assuming, and being accepted in, a leadership position within the multi-stakeholder process. It is essential that the facilitator has the skills and knowledge for leading groups in learning, participation, MSPs, conflict management, team work, etc.

Participatory learning and action

There are many different participatory methods, developed in various contexts and for a diversity of purposes. The first generation of methods were called Rapid Rural Appraisal (RRA) and Participatory Rural Appraisal (PRA). Since the 1990s, participatory methodologies have expanded and spread, and their focus has shifted from appraisal and analysis to planning, action, and monitoring and evaluation. Increasingly, they were applied in urban as well as rural settings. The focus shifted from applications in the field addressing technical and management issues to applications in organizations, addressing institutional issues as well. Their applications broadened from a few sectors in the rural and agricultural domain to many others such as nature management, health care and education. The topics addressed changed from ‘safe’ technological problems to sensitive, difficult and dangerous socio-environmental and ‘political’ issues. The first practitioners were NGOs; now these methods are applied within government departments, international donor agencies and within academic research performed by research institutions and universities. This move also contributed to the formation of a critical body of theory, whereas the original concept was founded on practice. From its region of origin in South Asia, participatory methods moved around the South and are now increasingly used in the North. They have evolved from methods into processes facilitating professional, institutional and policy development, and in this context attention has shifted from behaviour and attitudes to personal change and relationships. These gradual changes and what we have learned from them – above all the realization that good practice is empowering – led to a new name for the methodology. The term Participatory Learning and Action (PLA) is now widely used (often interchangeably with others, including PRA); this is the term we use in this section. PLA stands for “a growing family of approaches, methods, attitudes, behaviours and relationships that aim to enable and empower people, aim to share, analyse and enhance their knowledge of life and conditions, and aim to plan, act, monitor, evaluate and reflect”.¹⁶ Good PLA is about empowerment.

Principles of participation

We distinguish certain principles that support participatory methods and processes. The first of these is critical self-awareness and responsibility on the part of

facilitators: facilitators need to be conscious about attitudes, behaviour and relationships, to embrace and learn from error and doubt, to try continuously to do better, to build their own learning and improvements to the methods applied into every experience, and to take personal responsibility. Critical to this principle is changing behaviour and attitudes, abandoning dominating ones in favour of facilitating, gaining rapport, asking (often 'disadvantaged') people to teach us, respecting them, having confidence that they can do it, handing over the stick, empowering and enabling them to conduct their own analysis. The second principle is a commitment to equity, and to empowering those who are marginalized, excluded and deprived: the poor, or women and children. The third principle recognizes and celebrates diversity, i.e. offsetting biases (spatial, project, person - gender, elite, seasonal, professional, courtesy) and facilitating a culture of sharing of information, methods, field experiences and learning among NGOs, government and local people. The fourth and final principle relates to the facilitation and enhancement of participants' capacities for joint or social learning. Methods need to be flexible, exploratory, interactive and inventive if they are to facilitate rapid progressive learning. They need to include role reversals, i.e. learning from, with and by local people, eliciting and using their criteria and categories. They should include appropriate triangulation through using dissimilar methods, sources and disciplines, and a range of informants in various places, and through cross-checking to get closer to the truth through successive approximations, while always aiming for 'optimal ignorance' and 'appropriate imprecision'. This means not finding out more than is needed, not measuring more accurately than needed, and not trying to measure what does not need to be measured. We are trained to measure things, but often trends, scores or rankings are all that are required. Visualization techniques are used in meetings to ease the communication between professionals and rural participants, and also to stimulate dialogue amongst all the participants. These techniques include various formats such as tables or matrices, maps, flow charts and diagrams. The facilitator guides the participants through a series of methodological stages. The group dynamics that emerge in such a meeting give more trustworthy results than those which are obtained through individual interviews.²⁰

A blend of these methodological learning components characterizes a systematic process of social and joint learning (the fourth principle) engaged in by the stakeholders through joint analysis and interaction. It is important to reflect upon the various interpretations of reality and solutions for problems, and thus to support the emergence of multiple perspectives. This contributes to group learning processes in which group analysis and interaction are strategies to deal with this complexity. As far as possible, methods and approaches should be designed or adapted to the local situation, preferably by the stakeholders involved, enhancing their ownership. The process of joint analysis and dialogue helps to define changes which would bring about improvement, and to motivate people to take action to implement the changes.

These principles provide guidance when working with a farmer family, families within a community, and other stakeholders in a participatory learning and action process. In processes involving more participants (which is in fact always the case) it is important to consider these principles because of the diversity of participants

involved. This also means diversity in thinking about the importance of participation, the meaning of participation and ways of achieving empowerment. Working on the basis of these principles, which will demand investments of time, will increase the impact of the process and its results.

Facilitating participatory learning and change processes

Facilitation is critical in the participatory approach. The role of the professional is to guide the process; in all matters, decisions should be left to the group involved. This is often difficult as professionals such as researchers and extension workers are trained in transferring technology, telling the farmer how to do things, and making the farmer listen instead of talk. In participatory diagnosis and research, the information flow is reversed. It should be realised that this requires not just a change of attitude of the professional. Farmers and rural people may also be used to being told what to do and therefore may be reluctant to move into another mode of communication. Transparency and clear explanations of the objectives of the meeting will help both parties to start communicating in a different way.

Box 1.1 Robert Chambers' tips for being a successful facilitator²¹

- Look, listen and learn. Facilitate. Don't dominate. Don't interrupt. When people are mapping, modelling or diagramming, let them get on with it. When people are thinking or discussing before replying, give them time to think or discuss. (This sounds easy. It is not. We tend to be habitual interrupters. Is it precisely those who are the cleverest, important and articulate among us who are also most disabled, finding it hardest to keep our mouths shut?) So Listen, Learn, Facilitate. Don't Dominate! Don't Interrupt!
- Embrace error. We all make mistakes, and do things badly sometimes. Never mind. Don't hide it. Share it. When things go wrong, it is a chance to learn. Say 'Aha. That was a mess. Good. Now what can we learn from it?'
- Ask yourself - who is being met and heard, and what is being seen, and where and why; and who is not being met and heard, and what is not being seen, and where and why?
- Relax. Don't rush. Allow unplanned time to walk and wander around.
- Meet people when it suits them, and when they can be at ease, not when it suits us. This applies even more strongly to women than to men. Participatory methods often take time, and women tend to have many obligations demanding their attention. Sometimes the best times for them are the worst times for us – a couple of hours after dark, or sometimes early in the morning. Ask them! Compromises are often needed, but it is a good discipline, and good for rapport, to try to meet at their best times rather than ours; and don't force discussions to go on for too long. Stop before people are too tired.
- Ask open-ended questions. Use six helpers: who, what, where, when, why, how?
- Allow more time than expected for team interaction (I have never yet got this right) and for changing the agenda.
- Enjoy! It is often interesting, and often fun.

Facilitating experts and stakeholders may have a position as outsiders; they are researchers and/or practitioners who are not members of the community or group with whom they interact. For local people, they may act as catalysts to decide what to do with the information and analysis generated. Outsiders may also choose to further

analyse the findings generated by participatory learning and action or multistakeholder processes, to influence policy-making processes. If local people feel that such support is needed, the facilitating organization needs to commit itself to assist and monitor those actions that people have decided on.

The role of the professional has therefore changed from that of an “expert” to that of a “facilitator” The “qualities of a facilitator” need to be both dynamic and receptive; facilitation becomes a balancing act! Listening skills are an important quality. The attitude of the facilitator is crucial to success, and much more important than his or her ability to apply participatory tools. In summary, Robert Chambers provides a number of practical tips for facilitators; these are presented in Box 1.1.

Facilitating learning in participatory processes

Within PLA, learning is seen as ‘reflecting on experience to identify how a situation or future actions could be improved and then using the knowledge to actually make improvements’. This can be individual or group-based, within a project or programme, at organizational level or within a wider societal context. What is important is to ensure that each individual shares his or her thoughts and that others can learn from this. Jointly, a comprehensive picture is created.

Figure 1.3 Kolb’s experiential learning cycle²²

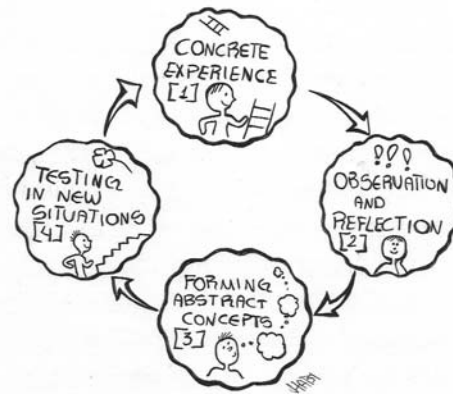

In the early 1970s, David Kolb and his colleague Ronald Fry at the Weatherhead School of Management developed “The Experiential Learning Model”.²² This model is composed of four elements: (i) concrete experience, (ii) observation and reflection of that experience, (iii) formation of abstract concepts based upon the reflection, and (iv) testing new concepts. The next step in the model is to repeat the four elements. Kolb and Fry indicated that deeper learning runs through a cycle of concrete experiences, reflective observation, abstract conceptualization and active experimentation (Figure 1.3). Applying lessons learned in future actions provides the basis for another cycle of learning. For example, when carrying out research one must first analyse and reflect on what are the issues at stake (reflective observation), e.g. context and problems encountered in the production of seed of a certain crop in a

specified locality. Once all the relevant information is collected one can start conceptualizing what this means, e.g. how the methods used by farmers to process and store seeds of that particular crop can be improved under the particular conditions (abstract conceptualization). This can then be tried out (active experimentation) to see if it really works, e.g. various experiments to find solutions to problems encountered in processing and storing seeds. Whilst undertaking this experimentation, one may discover new information or try out new ways of working (concrete experiences) that lead to better results, for example that the processing and storage needs to be differentiated for seeds of local and modern varieties of the crop. This needs to be reflected on, conceptualized etc. Basically learning is a continuous process of undergoing Kolb's learning cycle (Figure 1.3). This can be stimulated by using different tools/methods in different situations, e.g. problem tree analysis can be used before and after a particular project for the purpose of evaluation and thus reflecting on the changes over time and deciding what should be done in the future. Or a matrix can be used to make a decision about which crop varieties can best be introduced in a community; and a Venn diagram can be used for deciding which local organizations can facilitate learning and which other (outsider) organizations can support the participatory learning process.

Participatory tools

There are many tools which can support both professionals and local people in understanding and learning about informal seed supply systems. In their guidebook, De Boef and Thijssen provide an outline of these tools.²³ They are not prescriptive, but provide options one can draw from. Creativity is important for adapting the tools to the context so they can be used for field-based visualization, interviewing and group work. The common theme is the promotion of interactive learning, sharing knowledge, and flexible, yet structured analysis. Which tools should you use in a diagnosis aiming to increase your understanding, or that of farmer communities, about such topics as informal seed supply, dealing with farmers' problems in seed selection, storage or processing, or what type of varieties they prefer. What type of tool (map, matrix or any other) should you use, with whom, and in which sequence? The answers to these questions depend very much on the setting and the objectives of the exercise. While designing and applying tools, it is important to take into account that they can continuously be adapted and modified. We would like to conclude by emphasizing what we consider a critical point: that for a successful learning and action process through using these tools, facilitators should remember that behaviour and attitudes are more important than the methods and tools used.

1.5 Seed professionals starting to approach informal seed supply through a learning and action oriented training programme

*Marja H. Thijssen, Abdurahman Beshir, Zewdie Bishaw,
Anthony J.G. van Gastel, and Walter S. de Boef*

Ethiopia is characterized by a huge diversity in agro-ecosystems, crops and varieties. Agriculture is dominated by small-scale farming and the informal seed system, in which farmers select their crops and varieties, produce their own seeds, or locally exchange and purchase seeds, is supplying around 90% of the seeds.* Through improving the efficiency of the seed system, the Ethiopian Government aims to increase agricultural production and productivity, ensuring food security and improving the livelihoods of small-scale farmers.⁵ The Ethiopian Seed Enterprise (ESE) is the main provider of seeds in the formal system.[†] With the Farmer-Based Seed Production and Marketing Scheme (FBSPMS) the ESE involves farmers in contractual on-farm seed production; in 2005 about 25% of the certified seed produced by the ESE was produced through the FBSPMS. [‡] Currently, the ESE is looking for ways to increase the efficiency and sustainability of the scheme and farmers' seed production.

From October 2006 to October 2007, the ESE and its partners in the FBSPMS, and the Capacity Development and Institutional Change Programme of Wageningen International (of Wageningen University and Research Centre: Wageningen UR) and the Seed Unit of the International Centre for Agricultural Research in the Dry Areas (ICARDA) worked together in a tailor-made training programme addressing informal seed supply in Ethiopia. With the programme, the ESE and its partners, i.e. the Bureau of Agriculture and Rural Development (BoARD), federal and regional research organizations, the Ministry of Agriculture and Rural Development (MoARD), the Institute of Biodiversity Conservation (IBC) and national universities, intended to strengthen their capacities in the application and utilization of participatory approaches supporting seed supply and introducing a genetic resource focus into their work. The aim was to address better, through the use of participatory approaches, the seed needs of small-scale and resource-poor farmers in Ethiopia. This section outlines the structure of the training programme and its different activities, and describes the main achievements and lessons learnt. Other chapters present the first outputs of the training programme on the establishment of community-based or small-scale seed

* See Section 1.3 by Walter de Boef and Zewdie Bishaw on formal and informal seed systems.

[†] See Section 1.1 by Zewdie Bishaw, Yonas Sahlu and Belay Simane on the status of the Ethiopian seed industry and the role of the ESE in the formal seed sector.

[‡] In Section 1.2, Yonas Sahlu, Belay Simane and Zewdie Bishaw provide more details on the functioning of the FBSPMS.

enterprises,* opportunities for policy development supporting informal seed supply of local crops and varieties as a result of the training programmes policy workshop,† and opportunities for further supporting informal seed supply in Ethiopia.‡

Objectives of the programme

The overall objective of the training programme was to enhance informal seed supply, while targeting poverty reduction and the improvement of the livelihood of small-scale farmers. With this objective, the programme aimed to develop informal seed supply pilot projects in four regions, addressing the three areas: (i) enhancing the performance of the formal seed sector (research, extension, seed agencies) using strategies to support the informal seed sector; (ii) enhancing the performance of the informal sector through strengthening and establishing farmer organizations and community-based and small-scale seed enterprises; and (iii) enhancing the linkage between seed supply and the use and conservation of genetic diversity. Key strategies in achieving the above objective and contributing to the three focal areas were the following: (i) a participatory approach enforcing linkages between farmers and seed professionals; (ii) a multi-stakeholder approach enforcing linkages between diverse stakeholders involved in seed sector development; (iii) a regional and location specific approach bringing together stakeholders within identified regions and locations; and (iv) a learning and action approach, in which the regional teams participate in the training programme and at the same time are engaged in action to develop and implement a local informal seed supply project with the characteristics described above.

Training partners and participants

The training programme was organized by Wageningen International and ICARDA's Seed Unit. Professionals from these two organizations coordinated and facilitated the training activities, together with the national programme coordinator from the ESE. They were supported by a team of Ethiopian resource persons from the ESE, the Southern Agricultural Research Institute (SARI), and Mekelle University. Depending on the focus of the specific training activity, additional resource persons, representing Ethiopian organizations like the MoARD, the IBC, and Addis Ababa University, or international organizations like the International Wheat and Maize Improvement Centre (CIMMYT), Bioversity International, and the Association for Strengthening Agricultural Research in Eastern and Central Africa (ASARECA) contributed to the training.

* See Section 6.2 to 6.6 in which the regional teams from Amhara, Oromia, Southern and Tigray regions present their plans of and first results with the establishment of community-based and small-scale seed enterprises.

† See Section 7.5 by Walter de Boef and Anthony van Gastel presenting the outcomes of a workshop within the framework of the training programme addressing policy issues.

‡ See Section 1.6 by Johannes Engels and colleagues, linking all experiences presented in this book with a 'robust seed system' perspective.

The participants of the training were representatives from the broad range of stakeholders involved in seed supply in Ethiopia, including the ESE, the regional BoARD, Federal and Regional Agricultural Research Institutes, the MoARD, universities and NGOs. Participants worked in five regional teams from Amhara, Oromia (two teams), Tigray, and the Southern Nations, Nationalities and Peoples Region (“Southern team”).

Training approach

In the programme, Wageningen International and the ICARDA Seed Unit introduced a multi-stakeholder (MSP) process approach, engaging the participants in learning and action research on the use of participatory approaches in improving farmer-based seed production and revitalizing informal seed supply of local crops and varieties. Wageningen International and ICARDA staff, together with the international and Ethiopian resource persons, formed an interdisciplinary team that facilitated the learning process and guided the participants through the three steps of the MSP model interventions of planning, acting, reflecting, and again planning. The model was applied throughout the different training activities over the whole one-year period of the training. The basic approach was to translate the theory and concepts, case studies and field exercises provided by the trainers and resource persons into the participants’ actual working situations. In this way, Wageningen International, ICARDA Seed Unit and partner organizations aimed at building a new professionalism that could guarantee the sustainability of the programme and the overall effectiveness of formal sector agencies’ support to farmer-based seed production and informal seed supply.

Structure of the training programme

The programme consisted of seven training components: (1) a training workshop on participatory approaches in supporting seed supply and genetic resources management, (2) a training workshop on practical aspects of seeds and seed enterprise development, (3) a regional participatory seed system analysis, (4) a design and planning workshop, (5) regional workshops (four) in Amhara, Oromia, Southern and Tigray region, (6) a national seed policy workshop, and (7) an Eastern Africa regional workshop concluding the training programme. The following paragraphs provide more details on the different training activities.

Phase 1: training workshops – integrating theory and practice

The first workshop addressed participatory tools, informal seed supply and genetic diversity. The one-week training was held at Hawassa University – College of Agriculture in October 2006. The workshop started with an analysis of the achievements and limitations of the FBSPMS, and the participants’ expectations of the one-year training. In a series of sessions, the training workshop addressed participatory approaches to seed supply and related topics, e.g. formal and informal seed systems, community biodiversity management, participatory varietal selection and participatory plant breeding, community seed banks and informal seed supply. The programme integrated theory and concepts with case studies, and practising using the tools for participatory seed system analysis served as a preparation for field work. The

teams of participants practised by conducting a participatory field diagnosis in two locations in the Southern and Oromia regions, identifying problems in the informal seed system and genetic resource management. The results of the problem assessment were analysed and presented. Subsequently, the teams worked on the first phase of the design of action plans for a participatory seed system analysis in their own regions, with the aim of identifying the needs and options for the support of the informal seed supply. The way the workshop was set up, with concepts and theory addressed the first three days, followed by two days of field diagnosis, and concluding with one day of design, enabled the participants to go through three learning cycles, addressing the same topics in three different ways.

The second workshop addressed technical aspects and business approaches in informal seed supply. The one-week workshop immediately followed the first workshop and was implemented at Hawassa University – College of Agriculture in October, 2006. The training workshop focused more on the technical and institutional aspects of seed production and marketing, and business approaches supporting informal seed supply. The format of the workshop was similar to that of the first workshop, with three days addressing theory and concepts, two days of field study and one day of design. After the theoretical part of the first three days, the participants went to the field for a marketing survey, exploring with various stakeholders the options for establishing community-based and small-scale seed enterprises. The results of the field work were analysed and presented. The technical and seed enterprise development aspects were inserted in the design of the regional action plans as elaborated in workshop 1; action plans were discussed and again improved.

Phase 2: Diagnosis of seed systems and seed demand survey – translating knowledge into action

The participatory seed system analysis was implemented in the different regions in the period November 2006 – January 2007. After the two workshops, the teams returned to their work, institutions and regions. Within their organizations they discussed the plans for the participatory seed system analysis. They informed the local authorities and partner organizations on the training programme and their plans for the field diagnosis. With resources provided by the training programme and with technical and institutional support by four members of the Ethiopian resource persons' team, the regional teams conducted the seed system analysis. A report, written according to a specific format and submitted before training workshop 3, served as a tool for coordinating the training programme by monitoring and evaluating the progress within the different regional teams. For the teams it served as a basis for designing pilot projects to support informal seed supply in their regions in workshop 3. The reports addressed the following issues: the location of the diagnosis; the farming and production system of the area; the formal and informal seed system of the region; the methodology of the diagnosis, the diagnosis results (related to genetic diversity, crops and varieties used, changes in use of crops and varieties over time, seed sources, seed exchange systems, seed quality issues, seed storage, etc.); the results of the seed demand survey and business plan; and a tentative plan for a pilot project on the support of local seed supply. The five reports were evaluated by a team of international resource persons based on a number of criteria.

Phase 3: Diagnosis report and programme design – designing interventions to support informal seed supply

The four-day workshop was organized in Addis Ababa in February 2007. The workshop united the five regional teams, four members of the Ethiopian resource persons' team, a resource person from ASARECA, and Wageningen International and ICARDA coordinators/facilitators. In the first two days, the results of the participatory seed system analysis and the seed demand survey and business plans were presented and discussed, giving an insight into the problems and constraints for the support of informal seed supply in their regions. The teams had brought all the materials generated in the diagnosis, which were shown in a poster exhibition. Experiences in the regions were extensively discussed and compared, and improved where necessary, and preliminary conclusions were drawn. Through an analysis of the strengths, weaknesses, opportunities and treats (SWOT analysis) in seed supply in the different regions, coping strategies were identified and discussed. In the following two days, the regional teams, guided by the facilitators and resource persons, conducted a planning exercise to design a provisional plan for informal seed supply pilot projects in the regions. On the last day of the workshop, the plans were presented and discussed, including the planning for workshops in the four regions.

Phase 4: Regional workshops – engaging stakeholders in informal seed supply and the conservation of genetic diversity

Two-day workshops (for the Amhara, Southern and Tigray regional teams) and a three-day workshop (for the two Oromia teams combined) were organized in March and April 2007. The workshops were facilitated by the participants of the regional teams, supported by four members of the Ethiopian resource persons' team and coached by Wageningen International and ICARDA coordinators/facilitators. The participants in the workshops were representatives of all seed sector stakeholders in the different regions, including the ESE, the BoARD, the EIAR, the Regional Agricultural Research Institutes (RARIs), the MoARD, the Woreda Administration, Farmers Unions and Cooperatives, Farmers' Organizations and NGOs. The regional workshops aimed to contribute to the development of informal seed supply projects in the regions. Besides raising awareness among regional stakeholders on informal seed supply and the relevance of addressing genetic diversity when supporting seed supply, the workshop served to share the experiences and discuss the outcomes of the participatory seed system analysis, as well as to discuss and adapt the design for the establishment of community-based or small-scale seed enterprises with regional stakeholders. Together with the stakeholders, a regional vision on the support of local seed supply was developed and stakeholders' responsibilities in seed supply, and possible contributions and commitments to a joint pilot project were discussed.

Phase 5: Seed policy workshop – rationalization of policy and regulatory frameworks

The two-day workshop was organized in July 2007 in Addis Ababa. The general objective of the workshop was to address policy and regulatory frameworks related to genetic diversity and informal seed supply, contributing to: (i) raising awareness among stakeholders on informal seed supply and relevant seed policies; (ii) facilitating

sharing of experience among stakeholders active in the seed and genetic resource policy arena; (iii) analysing and discussing the bottlenecks within the current seed and genetic resource policies and regulations; and (iv) determining opportunities for the development/re-adjustment of seed and genetic resource policies and regulations. Two representatives of each regional team participated in the workshop. Two days before the workshop, the five teams came together to identify the main constraints on supporting local seed supply which result from current policy and regulatory frameworks. With this identification they set the agenda for the discussions of the workshop, in which key stakeholders representing relevant institutions at both the federal (MoARD, IBC, EIAR, ESE) and regional government levels (BoARD, RARIs and Cooperative Promotion Agencies), NGOs and international projects joined. The workshop addressed: variety release, plant variety protection and informal seed supply; seed regulations and informal seed supply; and biodiversity and genetic resource access laws and informal seed supply. The participants defined recommendations for seed policies and regulations that facilitate the support of informal seed supply.* After the workshop, the representatives of the regional teams had one more day for evaluation and further planning.

Phase 6: Eastern Africa regional workshop – sharing the experience within the wider region

The training was concluded with a last one-week workshop organized in Adama in October 2007. In this event the participants of the five regional teams, most of the resource persons that were involved in the training, additional representatives of seed sector stakeholders in Ethiopia, representatives of seed sector development projects and programmes from Kenya, Tanzania, and Uganda (three teams), and seed sector specialists from a range of other international organizations discussed the outcomes of the training programme and compared them with other experiences in the region. The main objective of the workshop was to facilitate a process of learning in the five regions and discuss ways to implement the approach as developed in the training programme on a wider scale.

Achievements and lessons learnt

This paragraph describes the main achievements and lessons learnt from the training programme, in the three focal areas it addressed: (i) enhancing the performance of the formal seed sector to better support the informal seed sector; (ii) the establishment of community-based and small-scale seed enterprises; and (iii) linking seed supply and the use and conservation of genetic diversity.

Enhancing the performance of the formal sector to better support the informal sector – institutional aspects

The participants of the training programme represented Ethiopia's major seed sector stakeholders from the formal sector in research, extension and seed supply. The multi-stakeholder approach, the regional and location-specific approach, and the learning

* See Chapter 7.5 by Walter de Boef and Anthony van Gastel in which they share the outcomes of the policy workshop.

and action approach through which participants were engaged with their regional teams in the implementation of field activities, all contributed to strengthened working relationships between organizations. Participants saw this improved collaboration, not only within, but also between regions, as one of the major achievements of the training programme. The fact that the first seed crops were already in the field within the one-year span of the training programme shows the participants' motivation and the support they got from their organizations.

The participatory approach of the training programme – addressed in theory in the training workshops, but also in practice through activities like the participatory seed system analysis, the regional workshops, and the implementation of the first farmers' seed production activities – reinforced the link between seed professionals and the farmers of their region. The participants indicated that through the training programmes they came to appreciate the farmers' seed system, and found new ways of working together with farmers. Participants showed a new professionalism.

The ESE was the national coordinating agency leading the training programme, and it joined and assisted the regional teams in all their efforts. In future activities related to the support of informal seed supply and farmers' seed production, the lead and the main responsibilities will be with the regional BoARDs. The deputy heads of the BoARDs of the different regions have indicated their interest in and commitment to supporting the informal sector, recognizing its role in seed supply, food production, food security and poverty alleviation. The ESE has indicated its interest in staying involved in a more facilitating role. This will be a new role, going beyond the ESE's original mandate in seed supply, but fitting within its public function as a national public organization.

The training programme tried to work through the existing formal institutional structures, with the federal and regional formal seed sector organizations. MoARD approved and supported the approach of the training project. Though it is often more difficult to work through existing formal structures than to set up an additional parallel structure, it will usually lead to greater impact and sustainability, which are essential when trying to upscale pilot projects.

An important topic that needs to be addressed here is the existing seed policy and the accompanying legal and regulatory framework – which currently tend to support formal seed production. In the policy workshop, the training programme participants and other stakeholders at federal and regional level drafted a number of recommendations for designing a conducive seed policy, and stimulating formal sector organizations to support informal seed production.* Recommendations include the decentralization of the variety release system, the decentralization of seed quality control, and the development of a mechanism to support production based on 'quality declared seed'.

* See Section 7.5 by Walter de Boef and Anthony van Gastel with the recommendations related to policy development supporting informal seed supply.

Enhancing the performance of the formal sector to better support the informal sector – strategies and activities

The training programme participants indicated that through the training they gained a lot of knowledge about the informal seed system and of possibilities to support it, which is extremely relevant for their current jobs, and will be taken into consideration in future work assignments. Within the training programme, the regional teams aimed to focus on the establishment of community-based or small-scale seed enterprises. These are not the only strategies for supporting informal seed supply in its germplasm base, the production of quality seed, seed availability and distribution, and sharing of knowledge and information about seed (as indicators for a healthy seed system).^{*} Other possible strategies have been described in several chapters of this book. It is important to choose the right strategy in supporting informal seed supply, and to base it on the objectives and on a proper participatory seed system analysis. In Section 1.6, the different strategies are characterized in relation to their contribution to a ‘robust seed system’, according to the five concepts of: (i) agricultural biodiversity, (ii) community-based organization of activities, (iii) autonomy or self reliance, (iv) dynamism and flexibility, and (v) creating synergies. † The authors stress that gaining experience with one strategy may allow farmers to switch to another strategy. For example, they may move from community-based seed production to the establishment of a small-scale seed enterprise with a key group of farmers – an approach that is more guided by business principles.

The establishment of community-based and small-scale seed enterprises

All five teams have started with the implementation of pilot seed production activities, based on the needs and opportunities, as identified in the participatory seed system analysis and the seed demand survey. The plans and the first results, the constraints on their efforts, as well as opportunities identified for continuing with this approach are presented in Chapter 6.[‡] From the experiences of the teams, a number of lessons can be drawn, which we summarize here.

One of the main lessons is that establishing a small-scale seed enterprise is not without risks. Steps that can reduce the risks include: proper analysis and business planning; proper organization of the farmers; a diverse portfolio of crops and varieties; and linking up with sources of new varieties on the one hand, and with the market on the other.

Before large-scale implementation, a complete business plan (a plan for 3-5 years, including a break even analysis, a what if analysis, etc.[§]) is essential. The farmers – as the most important stakeholders – need to be involved in the development of the business plan, and the planning of seed production activities. Some of the ‘enterprises’

^{*} In Section 3.2 Bhuwon Sthapit and colleagues characterize a healthy seed system.

[†] See Section 1.6 by Johannes Engels and colleagues.

[‡] See Section 6.2 to 6.6 for the first results of the regional teams of the tailor-made training with the establishment of community-based and small-scale seed enterprises.

[§] See Section 5.2 by Anthony van Gastel, Zewdie Bishaw and Bill Gregg on business principles for the establishment of viable small-scale seed enterprises.

are still no more than farmer-based seed production units; but these may evolve to real small-scale seed enterprises in the future.

In the pilot activities, the teams worked with large farmer groups. These are difficult to organize and manage. It is recommended to start seed production activities with smaller groups. The farmers should be carefully selected, considering land holdings, capability and motivation for seed production. Farmers should be organized within legal structures, and shareholder agreements should be established.

Based on the seed system analysis and the demand survey, the teams identified crops and varieties for the small-scale enterprises. Only one group considered local varieties, while most dealt with few crops or varieties. To reduce the risks of the enterprise, a diverse crop and variety portfolio, including higher value crops, is essential to ensure the viability of the business. On the one hand, self-pollinated crops have small profit margins and risky markets; on the other hand, the production of maize hybrid seed of varieties in high demand (like BH540), is technically complicated and not without risk. New varieties may be introduced through linkages with variety development programmes. Alternatively, the introduction of a local variety improvement scheme (simple selection and value adding) may be considered.

For most of the teams there is a need to further elaborate the marketing strategies, to determine how to get the seed into the “mobility zone” of the farmers. Contracts with marketing agents and with the processing industry (e.g. for potato) offer an opportunity for an ensured seed market.

Linking seed supply and the use and conservation of genetic diversity

Ethiopia is very diverse in its agro-ecology, and rich in its crop and genetic diversity. Most farmers grow local varieties for several reasons,* including the fact that improved varieties are not available for a number of crops. Efforts to support informal seed supply may at the same time address the conservation of crop and genetic diversity. In the participatory seed system analysis, the regional teams identified preferences for local varieties in a number of cases, whereas in other cases improved varieties were clearly in high demand. The local varieties were included in the portfolio of the community-based or small-scale seed enterprise. And the teams considered a number of practices that support the conservation of genetic diversity and informal seed supply, such as diversity fairs and diversity blocks.† They are working on these alongside the more commercial seed enterprise approach.

When a small-scale seed enterprise aims to become a profitable seed business, it will not consider unprofitable crops and varieties. But if one adopts a livelihood perspective instead of a business perspective on supporting informal seed supply, the maintenance and use of diversity, one of the coping strategies of small-scale farmers in Ethiopia, becomes a key starting point.‡ The design of the training programme was

* See Section 3.3 by Girma Balcha and Tesema Tanto on genetic diversity and informal seed systems in Ethiopia.

† See Section 3.7 by Bhuwon Sthapit and colleagues on practices supporting community management of farmers’ varieties.

‡ See Section 1.6 by Johannes Engels and colleagues on the robust seed system perspective.

based on the achievements and constraints of the FBSPMS; the participants of the training programme are professionals working in the formal seed sector. This explains the business orientation of the pilot activities, i.e. going from farmer-based seed production to the establishment of small-scale seed enterprises. The strengthened collaboration between the stakeholders may allow for more work on community-based approaches in the future, i.e. moving from the strategy of farmer-based seed production to community-based seed production, and from there to the establishment of community-based seed enterprises, and perhaps community seed groups. The latter are completely embedded in the informal seed system, with a strong focus on the maintenance and use of crop and genetic diversity.*

Conclusions

Through its multi-stakeholder approach, the tailor-made training has not only enhanced the individual capacities of a cadre of professionals, but has also enforced collaboration between institutions, and helped them to address regional and national problems collectively, and to garner support from policy makers and senior managers for farmer-based seed production and informal seed supply. Based on the initial positive results, and despite some disappointments, the regional teams and their organizations (with the BoARD and the RARIs as the main implementing agencies) and many of the farmers involved in the pilot activities are all convinced that the community-based and small-scale seed enterprise approach is valuable for improving farmers' access to seeds. The lessons learnt will be reviewed in each region. Additional lessons can be learnt from other experiences documented in this book. We hope that the fruitful collaborations started at the regional and federal level, the enthusiasm and commitment expressed by all the stakeholders, and the initial positive experiences, will provide a basis for improving, elaborating and upscaling the initiatives started in the tailor-made training programme. All with the aim of improving the availability and access to seeds and varieties, and thereby improving the livelihoods of small-scale farmers in Ethiopia.

* See as an example of community-based seed production groups Section 5.6 by Krishna Devkota and colleagues.

1.6 Robust seed systems: integrating a genetic resource conservation and sustainable livelihood perspective in strategies supporting informal seed supply

Johannes M.M. Engels, Jean Marie Byakweli Vianney, Hannes Dempewolf and Walter S. de Boef

Informal seed supply is still the dominant system in Ethiopia, as in many other developing nations in sub-Saharan Africa. In 2002, the area covered by improved varieties reached up to 3% of the total cultivated area in Ethiopia,²⁴ and the formal seed system's share in this coverage is estimated to be about 10-20%. The informal seed supply is thus widespread; it is embedded in cultural, traditional, social, economic and even administrative structures. The formal seed sector, on the other hand, comes up against various limitations in trying to support farmers' seed supply, and its own way of operating often leads it to ignore opportunities to tap into the strength of the informal system.* In this section we do not want to take a position in favour of either the formal or the informal system; we consider them complementary and recognize the importance of both, and particularly of finding ways of linking them in their work on increasing seed security.

One distinguishing characteristic of the formal system is that it focuses on just a few crops and the provision of a limited assortment of varieties. This conflicts with a common livelihood strategy of farmers in complex, diverse and risk-prone environments, who use a diversity of crops and manage genetic diversity within varieties. Local varieties, and in the context of Ethiopia, 'local' crops, are considered critical, and part of farmers' livelihood strategies aiming for food security.

An issue with great relevance to a discussion of seed sector development is the fact that the agricultural sector in Ethiopia and many other sub-Saharan countries predominantly consists of subsistence farmer households and households practising very limited cash crop cultivation. Whether or not this group of farmers have the option to purchase 'formal' seed or 'formal varieties' is a key issue. The size of their land may be too limited to guarantee sufficient food; they may not be able to maintain their own seed stock and may be forced to seek seed or 'seed grains' in the market, reducing their options for choosing varieties.²⁴ If they cultivate cash crops, they may be interested in buying quality 'formal seed of improved varieties' for those crops, while continuing to use farm-grown seed or seed and varieties obtained through informal channels for their subsistence crops. The nature of subsistence farmers and their dominance in the sector has been ignored in the design of seed supply and crop improvement interventions. The question remains whether it is a conscious decision on the part of farmers when they choose between using farm-saved or 'informal' seeds, or purchasing 'formal' seeds and varieties. The answer to this question is extremely relevant to defining seed sector development strategies.

* See Section 1.1 and 1.2 by Yonas Sahlu, Zewdie Bishaw and Belay Simane.

In the current section, we construct a perspective, linking the following three dimensions:

- How to strengthen informal seed supply?
- How to strengthen farmers' or community organizations engaged in seed supply?
- How to link these with a focus on the use of diversity at the crop and variety level as components of farmers' and communities' livelihood strategies?

This last question emphasizes the use of diversity rather than specific support to farmers or communities in the conservation of local crops and varieties. We support a 'diversity for development' rather than 'conservation of diversity' ethic. In our approach to seed supply, we take a position that covers all the angles discussed in this book - the seed, conservation, breeding and seed business angles. Our aim is to integrate all these in an approach to strengthening farmer or community organizations, and to promote the use of a diversity of crops and varieties.

Robust seed system: terminology

We use 'diversity for development' as a starting point for supporting seed systems and farmer organizations. By doing so, we aim to remain close to farmers' livelihoods in countries with diverse agro-ecologies, crops and varieties. We consider this orientation a prerequisite for building a strong seed system. We also opt for diversity because we want to challenge major efforts that are being made in the seed sector, which tend to focus on few crops and varieties, and to take a business rather than a livelihood approach. A diversity orientation in seed supply creates options instead of dependencies; whereas seed interventions that focus on few crops and (improved) varieties tend to result in farmers becoming dependent on formal and commercial structures.

As a term for linking livelihood, diversity and seed supply, we propose '*robust seed systems*'. The term 'robust' refers to the concept of '*resilience*', linking ecological and social systems in natural resource and ecosystem management.²⁵ Generally speaking, robust systems are able to respond to changes in ecology, society and economy; they are 'dynamic' rather than 'static'. Such systems are 'flexible' and 'in flux' but at the same time 'stable' in providing services and desired outputs. This capacity to respond to change while contributing to the stability in livelihoods can be considered an attribute of resilience: defined by various authors with an adaptive approach to managing complex socio-ecological systems.^{25,26} We emphasize robustness at individual farmer household or local community level (livelihood and food security) rather than at national (i.e. food security) or global (i.e. climate change) levels, but without undermining such higher level aims or contributions to change. Robustness refers to farmers' or communities' options for responding to those changes in their local setting, whatever the changes in their agro-ecological and farming conditions, community or local economy and market conditions may be. An example of robustness was the quick response in the informal seed system of Rwanda, which managed to adapt after the severe political unrest in the mid 1990s by incorporating introduced or re-introduced germplasm (seed aid) at the community level. Likewise,

community seed banks in Tigray* were established to increase seed security (robustness of community seed structures) in time of war and drought.

We approach the term ‘seed system’ in an inclusive and holistic fashion and step beyond the division into formal and informal systems. The seed system includes the efforts of both the formal and the informal sectors, and the range of interactions that take place in conservation, crop improvement and seed supply. Moreover, these interactions include participatory approaches to crop research and experimentation. Such research addresses not only the technical aspects of the availability of and access to seeds and varieties, but also the livelihood of poor farmers’ households, the social-economic structure of their communities, and even the relevant national policies. Such integration in support to seed systems has been described by various authors.^{14,27,28,29} In this book Bhuwon Sthapit and colleagues link seed systems, participatory plant breeding, agrobiodiversity, and community management of agrobiodiversity.† Their perspective comes closest to our concept of a robust system, integrating seed systems, diversity, participatory approaches and, critical and often ignored, the emphasis on community or farmer organizations contributing to socio-economic and institutionally sustainable outcomes.

Robust seed system: characterization

This perspective incorporates five key concepts as components of robust seed systems. The concepts are highlighted in Figure 1.4. The first component is ‘*agricultural biodiversity*’, which features at four levels. The first level is diversity among and within *agro-ecosystems*, characterized by multiple crops and varieties grown in several systems, local inputs and less dependency on one source for one product. This level is critical in relation to seed systems, because it will create less dependency on single or few – often non-available – inputs, and because it is associated with locally specific agro-ecological processes (rainfall pattern, soil fertility, pollination). The second level of diversity is the *diversity of crops and their wild relatives*. This level of diversity varies greatly from crop to crop, with more genetic diversity involved in centres of diversity for a given crop. It includes crop-weed complexes (e.g. cultivated and weedy sorghum types) as well as crop-wild relative complexes. When crops and their related species are found together in the same field, geneflow from the weedy or wild species into the cultivated crop can occur, thus increasing genetic diversity. The third level concerns *diversity among and within varieties*, which is the variation from populations of wild crop relatives to cultivated modern varieties. The genetic diversity within varieties allows the farmers to create a genetic buffer against running complete crop failures, allowing the varieties to adapt to changing conditions. We consider a fourth level of agricultural biodiversity – the *farmers’ or traditional knowledge and practices* related to crops, varieties and agricultural production systems. The inclusion of farmers’ or traditional knowledge is critical, but it is often forgotten when developing strategies for the conservation and use of genetic resources.

* See Section 2.3 by Trygve Berg and Fetien Abay.

† See Section 3.6 by Bhuwon Sthapit and colleagues.

Figure 1.4 Graphic representation of the robust seed system and its attributes

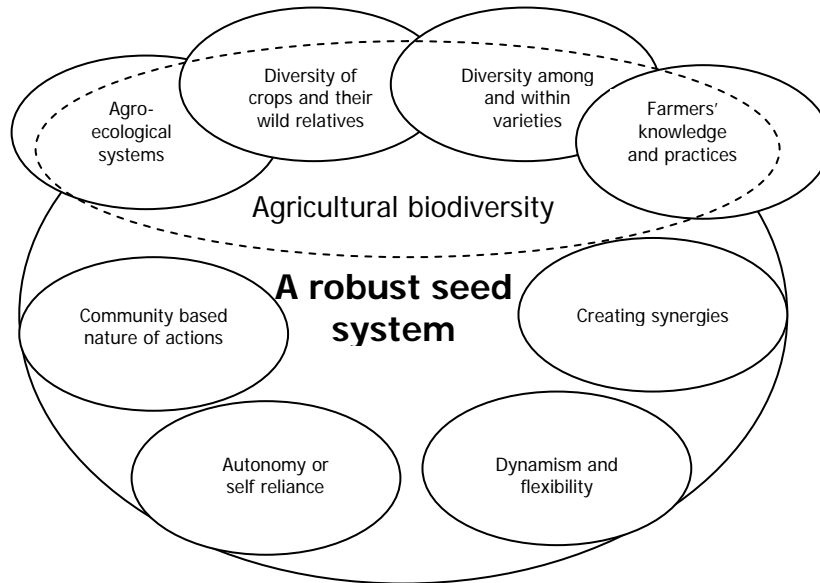

With the second component of the perspective defining robust seed systems, we stress the importance of *'community-based' organization of activities*. This component follows logically from our focus on agricultural biodiversity, as a community focus will stress local agro-ecologies, local crops and local varieties (i.e. diversity) as well as associated knowledge and practices. The seed systems should be embedded in local organizations and should be community-based in the sense that they should not depend or be made dependent on 'external' developments and technologies. The key issue here is farmers' ownership over the knowledge, resources and technologies, and respect for what they and/or their communities want to do with these. Within this context it is important to realize that communities and individual farmers often play an important role as 'evolutionary forces' in the context of genetic diversity, crop development and domestication – as has been demonstrated recently in the case of maize in Mexico.³⁰

The third component is *'autonomy or self reliance'*: this follows logically from the component emphasizing a community-based orientation of activities and organization, and means avoiding creating dependencies upon formal or any other systems. This entails autonomy in securing needed germplasm, in keeping and sharing traditional skills and knowledge associated with the seed systems, and in being able always to keep some strategic stock even in hard situations (war, drought, floods, etc.). In the informal system, it means counting on local social networks rather than depending on markets, commercial channels, public agencies and donors. Our position has more to do with ethical considerations than with creating controllable circumstances such as those envisaged in the debates on access and benefit sharing and farmers' rights. This concept has implications for the design of interventions strengthening seed systems, in

terms of the types of input, the choice of crops, and t varieties, and also in terms of the ways in which technology is designed and disseminated. With our inclusive approach to seed systems, we realize that this autonomy may primarily be achieved through the creation of enabling policies rather than through more technical or practical interventions.

The fourth component of robust seed systems is *'dynamism and flexibility'*. Here we follow the school of thought that says that seed systems need to respond to changes in agro-ecology and cropping patterns, be able to adapt to changes in society and organizations, and embrace economic opportunities. Our approach to dynamism in seed systems and interventions is to strengthen them in such a way that the system can incorporate new technologies and germplasm, and will evolve. Similarly, our approach to flexibility is to avoid trapping systems into rigid legal and policy frameworks (or even traditional structures) that could impede their dynamism and capacity to adapt to change. 'Dynamism and flexibility' are attributes of resilience that are inherent in the robustness of seed systems, thus contributing to stability in continuously changing and uncertain conditions.

The fifth and final concept which we believe is important when considering robust seed systems is what we refer to as *'creating synergies'*. The issue is linked to the discussion on strategies that support farmer seed supply, following either formal, informal or integrated pathways. Synergies can be realized through market channels and government interventions such as variety release, material transfer and information sharing, strategic provision of credit, and policy measures. This component means facilitating knowledge and material flows between the formal and informal systems, and also linking geographically distant 'informal systems'. An example can be given of the potential roles of national genebanks in this process. They are ideally positioned to facilitate links between distant parts of the country and/or with the rest of the world through providing farming communities with access to genetic resources and related information, or providing them from their own collections. In this function of providing access, community seedbanks can play a critical intermediary role.*

Linking the perspective to experiences in supporting seed systems

The robust seed systems perspective is powerful because it has the potential to assess the sustainability of a range of efforts supporting seed supply. We use the perspective to discuss interventions supporting informal seed supply, farmer and/or community organizations, and enterprises in seed supply, participatory plant breeding and conservation, as proposed and presented by many authors in this book. Herewith, we try to build a synthesis that integrates the aspects of agricultural diversity, participation, farmer and community organization, linking conservation to development, and supporting availability of and access to seeds and varieties.

The strategies for approaching seed supply presented in the book vary with the original objectives of the organizations – and often the donors - involved. Cases presented in Chapter 2 primarily target supporting farmers' management of seeds or

* See Section 3.5 by Jan Engels, Severin Polreich and Ehsan Dulloo.

supporting the informal seed system. Here we are dealing with often technical interventions enhancing seed quality and/or farmers' access to quality seed of improved or desired local varieties. In Chapter 3, cases are based on a conservation point of view on approaching seed supply. The focus on conservation appears clearly in the definition of the strategies, with their focus on local varieties and crops. Cases in Chapter 4 highlight participatory approaches in crop research and plant breeding, in which seed supply appears primarily as a tool for disseminating the results, i.e. improved or farmers' preferred varieties. Chapter 5 presents approaches to the establishment of small-scale or community-based seed producer groups or enterprises, while Chapter 6 presents initial efforts to establish such seed enterprises and production groups in Ethiopia. This strategy focuses on organizing farmers and takes a market/business approach to increasing seed availability and enhancing seed access. The experiences described in the book show that many of these efforts address one or two dimensions only. With the robust seed system perspective, we aim to take an integrated and holistic approach towards seed sector development while strengthening farmer or community organizations, and promoting the use of a diversity of crops and varieties with the overall aim of supporting farmers' sustainable livelihoods.

Continuum of strategies supporting seed supply

In order to assess the strategies with the 'robust seed system perspective', we placed them in a continuum, and used the book's case studies as reference. The assessment is guided by the perspective's five attributes: the four dimensions of agricultural biodiversity; community activities and organization; autonomy/self reliance; dynamism and flexibility; and creating synergies. Note that some of the cases would fit in more than one of the strategies; we have allocated them to one of the strategies to illustrate what we perceive, with components of robust seed systems in mind. The presented strategies cover a continuum from community-based organizations to commercial enterprises, from strategies strongly associated with the formal sector to those that are entirely embedded in informal structures. Table 1.17 summarizes this assessment.

Farmer management of local varieties: This strategy is chiefly motivated by objectives of conservation and farmer empowerment. A key objective of the organizations involved is to strengthen and establish community organizations that maintain and use, but also control, access to their genetic resources. They therefore focus on the availability of and access to seeds of local varieties. The book presents efforts of NGOs to support farmer management of local varieties in some South East Asian countries.*

Community management of local and improved varieties: The principle aim is to support communities in assuming responsibility for the management of agrobiodiversity. A process of farmer and community awareness raising and capacity building is central to this, but an additional indirect output is *in situ* conservation, within a dynamic approach to conservation. This strategy advances agrobiodiversity with a strong emphasis on creating and supporting community institutions, thus including many

* See Section 4.6 by Hans Smolders, Arma Bertuso and Bert Visser.

aspects of supporting informal seed supply. The book includes experiences of developing this strategy in Nepal and describes various projects in South East Asia.*

Community gene/seedbanks: Within a national framework for the conservation of genetic resources, community gene/seedbanks are local institutions in which communities take responsibility for the conservation of specific local varieties. The community gene/seedbanks have been established in various locations throughout Ethiopia with the support of the Institute for Biodiversity Conservation. The banks serve as a back-up system where farmers can obtain small quantities of seeds of local varieties, thereby strengthening the ‘conservation component’ of the informal seed system at the community or even national level. Because the banks work with small quantities, they do not contribute to local seed security in a quantitative sense, but in a qualitative one, by securing access to local varieties. The community/seed banks are founded to support the continued cultivation of local varieties and thereby contribute to *in situ* conservation on-farm. In this book, you will find experiences of working with this strategy in Ethiopia, and an account of its contribution to conservation, its institutional sustainability, and the opportunity it afforded for providing an interface between centralized and decentralized conservation activities.†

Community seedbanks: As a strategy for combating seed insecurity in times of risk (drought, famine or war), community seedbanks have been established in various countries. Their key objective is to establish community institutions that contribute to local level seed security, taking responsibility for the seed supply. By focusing on use, the strategy applied in the case studies from Tigray and Nepal‡ differs from the one applied in the community gene/seedbanks in Ethiopia. The seedbanks are more community-based institutions; we consider them more sustainable institutions. Conservation is achieved rather as a secondary than a primary output.

Farmer-based seed production: This strategy is applied when public, private or non-governmental organizations involved in seed supply work with farmers in the production of certified and/or quality declared seed of a set of varieties identified by those organizations. The relation between the ‘formal’ seed organization and farmers is defined by its contractual basis; farmers provide services producing seeds according to compulsory ‘formal’ standards required for certification or quality assurance. The seed organization may work with individuals or small groups, not necessarily organized through community organizations. The Farmer-Based Seed Production and Marketing Scheme as implemented by the Ethiopian Seed Enterprise (ESE) is a large-scale and prominent example of the strategy, unique in sub-Saharan Africa. Farmers receive training and through joining the scheme, in which seed becomes a commodity, they enter the business called seed production.§ What is critical, from a ‘robust seed

* See Section 3.6 by Bhuwon Sthapit and colleagues; and Section 3.8 by Arma Bertuso, Hans Smolders and Bert Visser.

† See Section 3.4 by Girma Balcha and Tesema Tanto; and Section 3.5 by Jan Engels, Severin Polreich and Ehsan Dulloo.

‡ See Section 2.3 by Trygve Berg and Fetien Abay; and Section 2.4 by Pitambar Shresta and colleagues.

§ See Section 1.2 by Yonas Sahlu, Zewdie Bishaw and Belay Simane.

system' perspective, is that this strategy 'formalizes' farmers' seed production and integrates farmers within the formal system. Through its formal setting (controlled by regulations), such a scheme works only with released improved varieties. The range of varieties and crops is limited, due to regulations, but also for logistical reasons. An important indirect output supporting the informal seed system is that farmers receive training and become skilled in seed production, albeit according to formal system standards and protocols. This approach indirectly facilitates initial interactions between informal and formal systems because farmers' access to knowledge, skills and germplasm is increased, and can be incorporated into the informal system. During such operations, the formal seed organization may obtain a better understanding of the functioning of the informal system.

Village-/community-/farmer group-based seed production: This strategy builds upon the previous one, however, with an important difference that seed organizations work through community organizations and not with individual farmers or farmer groups. In some cases, the strategy operates primarily within the formal system with only formally released improved varieties; in other cases it works in a collaborative manner, through testing identified varieties, organizing multiplication and facilitating dissemination of new, pipeline or even local varieties. Various sections of this book share experiences of working with diverse variants of this strategy. A first approach can be described as working in a decentralized mode contributing to seed security and increasing farmer communities' access to improved materials. Examples described in this book are village-based seed production in Afghanistan and the support for farmers producing seed of modern bean varieties in Uganda.* A second approach is establishing seed producer groups that evolve from farmer research groups, as described for farmers groups in Honduras, Central America.† Similar to research groups are those groups that evolve from working with participatory varietal selection and move on to the logical next step of seed production, or even make production of these new varieties their business. Researchers and breeders are supporting such farmer seed producer groups as a means to disseminate seeds of improved or pipeline varieties since no formal channels are effectively disseminating their breeding results.‡ A subsequent effort is the support of farmers groups' involvement in seed production as a means to increase local availability of improved varieties. The book shares a case study of farmer groups in Kenya, using an enterprise model to produce legume seed to contribute to seed and food security.§ The initial efforts of the team in the Amhara region supporting potato and maize hybrid seed production comes nearest to this strategy, as do efforts by the team in the Southern region, working with an irrigation cooperative to start hybrid maize production. The potato, wheat and field pea seed

* See Section 5.3 by Zewdie Bishaw and Antony van Gastel; and Section 2.6 by Losira Nasirumbi and colleagues.

† See Section 4.5 by Sally Humphries and colleagues.

‡ See Section 4.3 by Asrat Asfaw; and Section 4.4 by Fetiem Abay and Åsmund Bjørnstad.

§ See Section 2.7 by Mary Mburu and colleagues.

production efforts of the team in Tigray also use this approach.* Because of the technical requirements for hybrid maize and seed potato production, farmers' groups and cooperatives depend heavily on the technological inputs and assistance of service providers, resulting in a rather 'formal' approach towards farmer seed production.

Farmers' or small-scale seed enterprises are organizations that operate independently from the formal sector institutions. They operate within an existing cooperative structure, or are established as new small-scale enterprises. What is critical is that they are established according to business principles.† These enterprises work with a specific group of farmers: see successful experiences from Uganda, Bangladesh and Nepal documented in this book.‡ This strategy is interesting as seed enterprises can be instrumental in the dissemination of varieties produced through participatory varietal selection and plant breeding. However, it is critical to this strategy that the organizations are established with groups of individual farmers, so that they are less embedded in community structures, with implications for their institutional sustainability.

Community-based seed enterprises as a strategy combine a community-based with an entrepreneurial approach to seed production. Examples of this strategy in the book are the experiences of the FAO, and the efforts of the two Oromia teams working with farmers' groups and cooperatives as seed production enterprises.§ In the choice of crops and varieties, such community enterprises work with a range of varieties and crops, including local varieties. They are embedded in existing community structures or institutions, and are also more inclusive, seeking to include farmer households from various socio-economic strata. Their community focus is important: the scale of operation is local, and their main aim is to contribute to local seed security, rather than being driven solely by economic forces. It should be realised that even though enterprises established according to this strategy could be community-based, gradually they may develop with a key group of farmers into small-scale seed enterprises driven by business principles rather than local seed security. The two case studies from Bangladesh and Nepal show this dynamism in the type of business orientation. **

* See Section 6.2 by Amelework Beyene, Alem Yalew and Abebew Assefa; Section 6.5 by Tesfaye Tadese and colleagues; and Section 6.6 by Tadese Teweldebrhan and colleagues.

† See Section 5.2 by Anthony van Gastel, Zewdie Bishaw and Bill Gregg.

‡ See Section 5.4 by Soniya David; Section 5.5 Heleen Bos, Conny Almekinders and Kazi Borhan Amin Raj; and Section 5.6 by Krishna Devkota and colleagues.

§ See Section 6.1 by Osman Ibrahim; Section 6.3 by Shemsu Baissa and colleagues; and Section 6.4 by Messele Shimels and Assefa Senbeta.

** See Section 5.5 by Heleen Bos, Conny Almekinders and Kazi Borhan Amin Raj (Bangladesh) and Section 5.6 by Krishna Devkota and colleagues (Nepal)

Table 1.17 Assessment of various strategies supporting informal seed supply based on the Robust Seed System perspective

<i>Strategies supporting informal seed supply and type of organization</i>	<i>Assessment of strategies contributing to robust seed systems</i>			
	<i>Agricultural biodiversity</i>			
	<i>Agro-ecological systems</i>	<i>Crop species</i>	<i>Varieties</i>	<i>Traditional knowledge and practices</i>
Farmer management of local varieties	Local specific context	In principle all local crops	Local varieties	'Informal' – traditional – participatory
Community management of local and improved varieties	Idem	Idem	Local and improved varieties	Idem
Community gene/seedbanks	Idem	Idem	Local varieties and genebank accessions	'Informal' and 'formal' conservation
Community seedbanks	Idem	Idem	Local and improved varieties	'Informal' – traditional – participatory
Farm-based seed production	Seed production wide scale	Few crops	Few released improved varieties	'Formal' procedures and setting
Village/community/farmer group based production	Local specific context	Local staple and cash crops	Released, improved and local varieties	'Semi-formal' participatory – local
Farmers' or small-scale seed enterprises	Market defined	Econ. viable food and cash crops	Released and mainly improved varieties	'Semi-formal' – business – local
Community-based seed enterprises	Local market defined	Econ. viable and local crops	Released, improved and local varieties	'Semi-formal' – business – Local

Table 1.17 Continued

<i>Strategies supporting informal seed supply and type of organization</i>	<i>Assessment of strategies contributing to robust seed systems</i>			
	<i>Community based</i>	<i>Autonomy self reliance</i>	<i>Dynamic</i>	<i>Creating synergies</i>
Farmer management of local varieties	Individual farmers	Autonomous – local decision making and empowerment	Locally dynamic and specificity – limited external access	Informal – empowerment is objective
Community management of local and improved varieties	Community management	Idem	Idem	Idem
Community gene/seedbanks	Idem	Autonomous linked to conservation agency	Less dynamic - institution within conservation setting	Formal supporting informal
Community seedbanks	Idem	Autonomous – local decision making and empowerment	Locally dynamic – linking access to use	Informal structure and institution
Farm-based seed production	Individual farmers, groups or cooperatives	Contractual arrangement with public/private seed company/ programme	Little dynamic by economies of scale	Formal structure
Village/community/ farmer group based seed production	Community or farmer groups within community	Dependency for basic seed and technology from seed programme, NGOs	Locally dynamic, however with primary focus on few crops	Formal structure in informal setting
Farmers' or small-scale seed enterprises	Small limited groups within community	Semi-autonomous as enterprise – dependent on varieties and technologies	Business dynamic within larger economic setting	Informal – business – local structure
Community-based seed enterprises	Community management	Idem	Business dynamic within local setting	Informal – business and community

Conclusions

The robust seed system perspective has been useful for analysing the diversity of strategies presented in this book in the context of livelihood strategies, emphasizing the role of both diversity and seeds for development. However, one should realize that the perspective is only a social construct, a way of looking at activities and creating an organized view of a complex 'reality'. This reality is formed by the five components we have included in the perspective.

What we learned is that there is no one way to enhance access to and increase the availability of seeds and varieties. A range of initiatives support the seed sector, with varying attributes and implications for the seed system at large. The perspective illustrates that interventions are often based on one perspective (either business, dissemination of modern varieties, participatory varietal selection or conservation of local varieties) while the livelihood and rural people's food security is far more complex and requires the integration of these perspectives. We found that the integrative robust system captures better the complex reality and multiple dimensions at work, and facilitates synergy. It also reveals the deficiencies in interventions which take a simplistic or single oriented approach to increasing seed security. The perspective could be a guide to what type or sequence of interventions to plan and undertake. For example, how to move from farmer seed production toward community or village seed production and management, and from a focus on working with farmer seed production of released varieties of a few crops towards community seed producer groups or enterprises working with improved and local varieties of a wide range crops. Ways of gradually developing seed production schemes can be identified, linking components such as agrobiodiversity to community empowerment, stimulating dynamism and flexibility and seeking synergies in formal and informal structures. The resulting integrated approach appears to work towards more institutionally sustainable outcomes, thereby contributing to increasing seed security for diverse situations with the ultimate aim of increasing long-term food security at local and national levels, or even increasing the 'robustness' of those systems so that they are able to respond adequately to an unpredictable future.

Another conclusion is that conservation and development are not contradictory or conflicting objectives when they are properly managed. Interventions in the seed sector and beyond (breeding, conservation itself) can be assessed by their implications for genetic and crop diversity. Strategies that simultaneously support conservation and development can be identified. This aspect really goes to the heart of genetic resource conservation, combining in a livelihood oriented approach *in situ* and *ex situ* conservation strategies.

The robust seed system perspective demonstrates how to support subsistence agriculture and farmers' and community organizations' access to crop and genetic diversity through seed. Working through community and locally based (informal) structures appears the most sustainable way of managing genetic diversity in a production system and thus conserving it, i.e. contributing to the *in situ* conservation of genetic resources 'without freezing development'. What requires attention is the aspect of monitoring, i.e. when development starts to take place at the expense of crop and genetic diversity, genetic resources programmes will have to get involved in activities ranging from raising farmers' awareness of the genetic erosion to collecting and maintaining the threatened material in a genebank.

The perspective shows that taking a business oriented approach may result in partial rather than general seed security; it may exclude predominantly subsistence farmers from benefiting from the interventions, even though they are often considered a key target group. In some cases, these interventions may cause further disparity among members of communities, when seed interventions are embedded

within development frameworks, so there is cause for concern about the social impacts of using a business model. This does not mean that it is not a viable strategy; it may be most appropriate in situations where farmers do have resources or are required to purchase seed, or where for example NGOs purchase seed for relief. In situations involving subsistence farmers and specific crops and varieties for which no commercial seed market exists, informal networks and community structures for seed dissemination and exchange need to be enforced instead.

We have elaborated on the robust seed system as an inclusive perspective. Rather than aiming at a balance between the two systems (or absorption of one by the other), we enforce levels of integration, despite the normative dominance of the formal system. However, we emphasize the potential of the informal system and enhance the services it provides to seed security. Consequently, a demand emerges to enhance the capacity of stakeholders in using participatory approaches that will result in better integration and strengthen the informal system.

The perspectives illustrate how, especially in sub-Saharan Africa, communities of small-scale farmers or even subsistence farmers play key roles in managing diversity and contributing to seed and food security within a context of global challenges such as 'climate change' and 'globalization'. The occurrence of frequent floods and persistent drought in Africa is threatening food and seed security with their impact on the informal seed system (genetic diversity, impoverishment, social conflicts, etc). Increasing global food grain prices have an impact on local grain and seed markets. Do we now have options and alternatives? Globalization leads governments to pursue policies aiming at imposing the formal seed or commercial system as the single way of dealing with seed supply, thereby destroying the informal seed system. What is the future of communities that are not equal to these forces? Some other questions that come to mind include: Are communities of subsistence farmers the most vulnerable institutions in a globalizing and changing world environment or would they, because of their autonomy, be more robust? Is genetic diversity that is being managed within the informal seed system by empowered communities of subsistence farmers actually treasured by them or under threat?

When it is realized that the use and maintenance of a diversity of crops and varieties contribute to the empowerment of subsistence farming communities, and that they simultaneously contribute to development, the relevance of the robust seed system perspective becomes clear. It is the responsibility of research, conservation, extension and seed institutions and their professionals and policymakers to embrace these local institutions and organizations and seek proactive approaches that contribute to community empowerment.

2 Supporting informal seed supply

2.1 Supporting farmers in maintaining and selecting seeds of local varieties*

Conny Almekinders and Niels P. Louwaars

Maintenance and selection are important activities in crop improvement programmes. It is often assumed that variety maintenance and crop improvement are specialized activities that can only be performed by trained breeders. However, farmers too practise such activities, which are a critical part of the informal seed system for maintaining and improving local or adopted improved varieties. Methods of seed production practised within the formal setting can provide ways of enhancing the 'genetic quality' of seed produced by farmers within the informal seed system. This section presents some basic background and describes some techniques of variety maintenance and selection which may be used when supporting farmers' seed production.

Options for selection

Selection is an important aspect of seed production. Selection is done to:

- Improve seed vigour by selecting well-developed plants and plump seeds only (physiological and analytical quality);
- Reduce disease incidence by discarding obviously diseased plants or seeds (sanitary quality);
- Maintain the genetic quality of the variety (varietal identity);
- Continually adapt the variety to changing growing conditions; and
- Obtain better varieties.

There are different selection methods, realized during different phases of seed production. Before planting, in reverse order, these are:

1. Selecting healthy and 'true-to-type' seeds from the stored grain, i.e. seeds that resemble those of the mother crop and do not show obvious disease symptoms.
2. Selecting after harvesting, but before threshing and storage. This is a common method in maize and sorghum, where the best-looking ears and heads are kept

* This section is adapted from: Almekinders, C.J.M. and N.P. Louwaars, 1999. Farmers' seed production. New approaches and practices. London, Intermediate Technology Publications: pp. 119-131.

separately for seed. An advantage is that for small amounts of selected seed, drying and storage conditions can be given more attention.

3. Selecting while harvesting a particular field or part of the field that performs well. The selected portion is harvested separately for seed. The advantage is that seeds from well-developed plants with few disease symptoms are expected to be more vigorous and healthy.
4. Picking of individual plants just before the harvesting of the whole field. The advantage over method 3 is that it is also possible to select for the genetic composition of the variety.
5. Marking of particularly healthy and good looking individual plants during the season, e.g. by tying a ribbon around the stem of the selected plant, and harvesting separately (positive mass selection). At the same time, clear off-type or diseased plants may be removed from the field (negative mass selection). Compared with method 4, this allows for selection based on characteristics that are no longer visible at the end of the season, e.g. susceptibility to leaf diseases.
6. Selecting a field for seed production, separate from the crop production field, taking into account some isolation distance. Combining this practice with the roguing of off-type and diseased plants during the season can increase the selection pressure.
7. Performing a specialized selection procedure to maintain or purify the variety (see following section on variety maintenance).
8. Selecting a totally different environment for seed production, e.g. producing seed potatoes at a higher altitude to reduce disease pressures, and producing ware potatoes in the valleys.

These options are listed in order of specialization, and in order of efficiency in terms of genetic selection. The options divide into two types: in options 1 to 5, seed production is part of the crop production process, while in options 6 to 8 it is specialized and separate from crop cultivation.

In the first option, selection does not necessarily relate to plant characteristics and therefore carries a risk of genetic degeneration of the variety. For example, when some trailing beans are mixed with seed of a pure bush type variety with similar seed characteristics, the numbers of trailing plants will increase with time because the trailing plants produce more pods. Seed selection before planting can however be helpful for sorting out obviously poorly developed or diseased seeds, e.g. brown-spotted bean seeds affected by fungus or viral disease.

Options 6, 7 or 8 may be useful in very special cases, i.e. where uniform varieties are needed or where disease pressures are high. In large scale seed production this is by far the most preferable option, but in common agricultural practice this is only done in very specific situations.

Ordinary farmers generally perform selection methods 1, 2, 3, or 4, or a combination of them. There are, however cases in which farmers have developed more sophisticated seed production and selection practices. This happens for example where farm conditions are particularly suitable for seed production, or where particular farmers or farmer groups have a special interest in producing superior

quality seeds. In many situations, options 3 and 5 offer interesting opportunities to improve seed quality.

One effective refinement of options 4 and 5 is a method known as ‘grid selection’, in which plants are selected in relation to neighbouring plants. This means selecting plants that compare well with the neighbouring ones, rather than taking all the plants from a possibly more fertile part of the field. A good farmer will select outstanding plants from all corners of his field by comparing each plant with its neighbours.

Seed cleaning and removing diseased plants from the field is another form of selection. Even though such selection for non-genetic seed quality is important, selection is more commonly associated with variety maintenance or improvement. It is, however, important to realize that any selection for non-genetic seed quality may – perhaps unintentionally – affect the genetic quality of the seed. So the effects of selection can be unpredictable, and the effects of farmers’ selection methods can be detrimental (see Box 2.1).

Box 2.1 The effects of selection

- Early in the season, when vegetable prices are high, farmers are tempted to sell their vegetable beans. Only at the end of the season do they start thinking about seed for the following season. Some pods which develop late are left on the plant to produce seeds. Such plants may have contracted all kinds of diseases, some of which may be seed-transmitted. Moreover, the last seeds on a plant are commonly smaller, producing less vigorous plants.
- It has been observed that tomato and melon growers may sell their best-looking fruits in the vegetable market at a premium price, while oddly shaped fruits are eaten or used for seed. If the malformation of the fruit is genetic, such methods increase the chances of producing more poor quality fruits in the next season.
- Farmers often have particular early maturing varieties that provide food for the hunger season, i.e. the period before the harvesting of the main food crops. They are under severe pressure to use such early varieties for food rather than for seed. In early maturing maize crops, the earliest cobs are commonly picked for cooking, roasting or selling. This is likely to result in the maturity period of this variety getting gradually delayed. Similarly, early maturing bean varieties such as ‘Mesi Moja’ in Kenya (one month) and ‘saca pobre’ in Costa Rica may be lost completely where the temptation is to consume or sell the whole early crop.

Variety maintenance

Maintenance of diversity

Farmers generally select in their fields and in their seed stores, thereby preventing natural selection from introducing weedy characteristics into the crop, such as shattering seeds, weedy plant architecture and other characteristics that may be positive for plant survival, but negative for crop production. Variety maintenance is thus an important aspect of seed supply.

Maintenance of local varieties is a dynamic process whereby the farmer often selects on the basis of a particular diversity within the variety which is characteristic for that particular landrace. This is different from modern plant breeders who have an idio-type, or ideal plant type, in mind: a strategy which leads to uniformity. In practice, farmers do not maintain the variety in a strict sense. They maintain the variety's major features, but at the same time they can continually adapt the variety to changing conditions, e.g. a gradual decrease in rainfall or soil fertility, or to specific changes in the market. The genetic diversity which is present in landraces gives the farmer the opportunity to respond to such changes, and such selection within a genetically diverse variety does not necessarily lead to marked changes.

When cereal farmers pick individual ears for seed before harvesting the food crop, they often take a wide range of samples, thus maintaining the diversity of their local variety. This remains the basic principle, and they rarely select only the very best looking and very similar ears, although they may discard obviously weak and diseased plants, thus exerting some selection pressure. Another example is women bean farmers in Rwanda, who have been observed to intentionally mix differently coloured seeds to arrive at well balanced varietal mixtures for planting in different plots of their farm: mixtures for good soils, for shaded plots, etc. They could easily select single coloured seeds which are likely to result in more uniform crops, but the diversity offers a buffer against various possible uncertainties during the coming season, such as disease outbreaks, drought etc. Maize farmers maintain their varieties by choosing the average ears, and not the large ones. The latter method would necessarily lead to changes, not only of ear size, but also of other characteristics (Box 2.2).

Box 2.2 Poor selection in formal systems: KWCA maize in Uganda

Kawanda Composite maize became very popular in Uganda upon its release in the early seventies. Poor selection during a number of years caused considerable changes in the variety that made it far less adapted to local conditions. Selection method 2 was applied over a number of generations. Large ears from a specially planted field were selected for maintaining the variety. Plant characteristics were not taken into account. The result was that after a number of years the average plant height and the maturity period had increased, and the number of ears had decreased to 1. That the crop had changed in appearance can easily be explained by the selection method. Plants with large, good looking cobs generally have one cob per plant, whereas plants with two slightly smaller cobs may have a higher yield. Similarly, plants with large cobs are very competitive: they must have intercepted more sunlight than their neighbouring plants: they were taller, and they remained green longer. The result was that the increased maturity period made it difficult to grow two crops per year and to get the harvesting done during a dry season. Tallness caused lodging problems at the end of the season. One cob per plant was considered inferior to two cobs. It took a number of years of very specialized selection procedures to re-select KWCA to look more like the original variety.

Selection of landraces is more effectively done using methods 1 to 5. Methods 6 and 7 are particularly aimed at strict selection, i.e. increasing the uniformity of a variety that is too heterogeneous. This should be done with great caution, with clearly defined

objectives, and carrying out regular adaptation and yield stability tests. Too strong selection leads to genetic narrowing down of the variety, which may reduce yield stability and potential due to inbreeding depression (in cross-fertilizing crops).

Support to farmers in the maintenance of heterogeneous varieties should therefore be given with caution. It involves creating awareness about which types should be considered off-types (i.e. not belonging to the landrace), and removing such plants from the field, preferably before flowering. Selecting within a variety to adapt it intentionally to changing conditions or new needs is discussed in Chapter 4.*

Maintenance of uniformity

Selection is a different process for a modern (uniform) variety, where the aim is usually to avoid genetic degeneration, i.e. to maintain or to re-select the original variety. Regular selection is necessary in order to avoid the accumulation of off-types, which may not be optimally adapted to the conditions. Simple selection includes roguing of obviously off-type plants in the field, preferably before flowering of the crop, or during several rounds both before and after flowering (negative mass selection). Alternatively, a positive mass selection picks the best (true-to-type) plants out of a field, and then multiplies their seeds. With relatively pure varieties, this is effective and is enough to keep a variety sufficiently pure. Positive mass selection for uniformity in modern varieties of cross-fertilized crops is described in the section on cross-fertilizing crops.

When a good variety has become mixed during subsequent seasons of reproduction, it may be necessary to use method 6 to re-select the original variety. This may look like a very laborious and specialized task, but it can be a very effective way to assist farmers to improve their seed. Basic selection schemes are presented here in order to guide such specialist selection. A distinction has to be made between vegetatively propagated, self-fertilizing crops, semi-cross fertilizing crops, and cross-fertilizing crops. All these methods need separate fields to avoid unwanted cross-pollination, and close attention should be paid to avoiding inbreeding depression in cross-fertilized crops.

Self-fertilizing crops

When only little heterogeneity is observed in a uniform variety, simple mass selection can be used to maintain the variety. Mass selection can be done by removing the off-type plants (negative mass selection), or by positively selecting the preferred plants (positive mass selection); see Box 2.3 for an example from cowpea and sesame varieties.

When a uniform variety of a self-fertilizing crop shows considerable variation in the field, a so called pure line or ear-to-row selection can be performed. The latter name makes the method clear:

1. True-to-type ears (cereals like wheat or finger millet) or plants (pulses like beans or chickpeas) are selected and harvested separately.

* See various sections in Chapter 4 on participatory crop improvement and supporting informal seed supply.

2. The seeds from each plant are then planted together in separate rows or small plots.
3. If the mother plant was genetically pure, the row planted will be very uniform. If the mother plant was not pure, the row will show segregation, i.e. clear differences between the plants within a row. In this case the whole row should be eliminated.
4. Only rows which are uniform and definitely true to the variety are harvested for seed.
5. The seeds from the uniform-looking rows can be bulked.
6. If an extra cycle of selection is still needed for more uniformity, the seeds from the different uniform rows are kept separately. They can be planted in blocks in the following season. The blocks will be larger than in the preceding season, allowing more precise evaluation. Blocks which are not uniform are eliminated.
7. Selected blocks are bulk harvested and multiplied for distribution to the farmers.
8. It is strongly advised not to keep only one uniform row or block for further multiplication. This particular row may have invisible faults, such as poor resistance to a disease that is not very prevalent during that particular season. It is better to select 10 or more similar-looking rows. Moreover, this favours a more rapid multiplication.

When different modern varieties of a particular crop have to be maintained in the same field, some rows should be planted around each selection block, separating the different varieties. These rows should not be harvested for seed, because some cross-fertilization or mechanical admixture may occur even in self-fertilizing crops.

Box 2.3 Recuperation of degenerated seeds of cowpea and sesame

Seeds of local varieties of cowpeas (self-fertilized) and sesame (semi-cross fertilized) have been grown with success for many years. Because of poor maintenance, the varieties have become too diverse: the variation in plant height among the plants increased after the introduction of some modern varieties of the crop in the area. The result is that the shorter plants do not develop sufficiently, they contract various fungus diseases, and the produce is of very poor quality.

The applied strategy for regeneration is to regain the original local variety by exerting a low selection pressure within the variety. One possible method would be to remove plants which are too tall or too short (negative mass selection); another option would be to select average size plants (positive mass selection). Inbreeding depression should not be feared in these crops, but the original level of diversity should be attained, so selecting a sufficiently large number of plants is a must.

If the original variety was already very diverse in plant height before the introduction of modern varieties, negative mass selection can be used. This removes the extremely tall and small types and maintains the original diversity. If the original variety was rather uniform in plant height and there was little variation in the degenerated variety, positive mass selection can be applied, and selection of a few plants of similar heights will provide the basis for further multiplication.

Vegetatively propagated crops

From a genetic point of view, variety maintenance of vegetatively propagated crops is easy. Single plant selection, alone or in combination with 'ear-to-row' multiplication, will eliminate off-types very effectively. The main problem of maintaining varieties (clones) of vegetatively propagated crops is to keep the stock free from diseases. Very strict selection for disease free plants in rows can be effective, assuming that measures are taken to avoid the spread of diseases within the selection field. This can be done by planting other crops between the lines or by early spraying with fungicide. Regular spraying of systemic insecticides against the spread of insect-transmitted viral diseases can be useful when applied in large areas.

A variety may be completely infested with viral diseases. If healthy plants cannot be found, it may be possible to eliminate the disease through tissue culture in a research station. This is a costly exercise which is only useful if there is some guarantee that re-infection with the disease in the field can be avoided. If the chances of re-infection are high, the best option may be a large-scale multiplication scheme in a 'clean' environment. Plants can then be distributed to replace all infested materials in a particular area (e.g. virus-infested cassava).

Cross-fertilizing crops

Maintenance selection of cross-fertilizing crop varieties is more complicated than that of self-fertilizing varieties. The main difference is that a cross-fertilizing variety may suffer from 'inbreeding depression', when it becomes too uniform. Also, selecting a small number of plants may result in genetic drift, i.e. a gradual shift in some characteristics of the variety. This means that selection does have its limitations: too strong selection will result in a gradual reduction in yield. A second problem is that apparently healthy plants may have been fertilized by very poor plants, so that although selection of their seeds multiplies the good characteristics of the mother plant, it also multiplies the poor characteristics of the pollinators. The simplest procedure is mass selection for which three methods exist:

1. In negative mass selection, off-types or bad-looking plants are eliminated; the harvest from the rest of the plants can be used as seed.
2. In positive mass selection, the best plants are selected for seed production.
3. In stratified mass selection or grid selection, seed is selected from plants distributed equally in the field, and plants which compare well with their neighbours are selected for seed. This method reduces the risk that differences in field conditions (soil fertility, irrigation) result in selection of plants from only one side of the field.

When using the latter method, one should guard against selecting too few plants, to decrease the risk of inbreeding depression or drift, which would be counterproductive. Many farmers use or are taught the principles of stratified mass selection as a means to support farmers' seed production. See an example of farmers practising stratified mass selection in Box 2.4.

Box 2.4 Farmers practising stratified mass selection in Brazil

Farmers in the municipality of Anchieta, Brazil, practise stratified mass selection in seed production, crop improvement and maintenance of local maize varieties. The seed production area is usually divided into equal areas with rows of 5 to 10 meters. In each row, farmers identify an equal number of plants considering the best exemplars, representing the variety (for maintenance and seed production) or the best performing individual plants (for crop improvement). A common practice is to plant a variety in an area of at least 800 m² or 3000 plants, of which 400 are selected. At this density, farmers collect one ear every two meters in a row, thus maintaining the variety without any loss of variability, while selecting the best plants according to their preferences. Agronomic characteristics taken into consideration include plant height, ear position, ear diameter, diseases and pests. Harvesting is followed by selection at home.

For variety maintenance, the procedure is as follows: From the 400 ears selected in the field, 200 ears are selected using the criteria of grain type, ear appearance, colour, weight, healthy appearance, etc. The ears are kept in the husk, and further dried in the shed for 45 days before the seeds are removed from the ears. From each of the 200 ears, 18 grains are taken from the central part and germinated. If the germination rate is 85%, then 3060 plants will be grown the next season. In addition, farmers maintain another duplicate seed lot of 18 grains per ear. This is to secure the variety in case of crop loss during the next season. The maintained grains can be used for seed production. Farmers within the Local Maize Variety Producer Association in Anchieta (ASSO) maintain a range of local varieties, while at the same time engaging in commercial seed production of their local varieties. Some farmers in this group are also involved in farm-based breeding, and in participatory plant breeding projects with formal institutions.

A more advanced maintenance procedure is the following form of ear-to-row selection:

1. Select at least 200-500 healthy-looking ears (maize, pearl millet) or heads (sunflower), i.e. those which are well developed and have all the typical characteristics of the variety, but are not necessarily the biggest.
2. Plant rows with the seeds of each plant. These rows may consist of 10 to 50 plants (so called half sibs) depending on the available field size.
3. Remove the poor-looking rows, preferably before flowering.
4. Remove the most irregular rows, preferably before flowering, and harvest the other rows and bulk the seed.
5. Select the best plants or ears within the good rows to start a new selection cycle.

This selection is quite 'soft' and will be effective when executed for a number of seasons.

When a variety has been very 'contaminated' because of many years of production without selection, or a problem with isolation, the above procedure may be refined through two methods: the remnant seed method and the full sib selection. The remnant seed method is an ear-to-row selection. Seed is harvested from selected healthy and true-to-type plants; seeds of individual plants are kept separately. Only half the amount of seed harvested from a plant is sown in rows. If a row looks uniform, the seed that has been saved is bulked with seed saved from other rows. During the first stage, part of every ear or plant is kept in store because the plants of

the selected lines in the field may be pollinated by neighbouring (non-selected) lines, which considerably reduces the selection efficiency. When the rows are planted, some seed from each plant/ear/head is kept in properly labelled bags and stored. In the field, off-types may remain in the rows, but poor plants are labelled during several selection rounds over the season. Only the best half sib lines (at least 50!!) are selected. The remnant seed is taken from the store, bulked and planted the following season. If less than 50 are selected, there is a serious risk of inbreeding and thus of reduced yields.

During full sib selection, two good looking plants may be artificially crossed. This is relatively easy with maize, but very difficult in many other crops. The crossed ears then provide the seed for the rows for selection (whether or not the remnant seed method is used). When a variety has become relatively pure, these selected lines may then be planted in the middle of a field planted with seed of a mixture of the selected heads. In the case of maize, the plants in the rows are detasseled in order to allow the surrounding plants to fertilize the selected ones. This reduces the risk of inbreeding and protects the selections from pollen blown in from other fields. Full sib 'rows' should be selected for the main characteristics of the variety and for uniformity. They should not be selected for yield because heterosis may 'blur' the observation.

It is virtually impossible to maintain different varieties of cross-fertilizing crops in the same field. The isolation distance between the fields has to be large in order to prevent pollen from one variety contaminating another. Planting tall crops between two varieties may reduce this risk in wind-pollinated crops (e.g. tall elephant grass surrounding maize selection plots), but this does not work for insect-pollinated crops (sunflower, radish, cabbage). In some conditions it is possible to stagger the planting of different varieties: planting the different varieties at different times prevents them flowering at the same time. If conditions permit, however, it is much safer to concentrate on one variety in one year and on another in the following year.

Semi-cross fertilizing crops

Selection of semi-cross fertilizing crops does have to take crossing behaviour into account, but these crops generally do not suffer from inbreeding depression. This means that maintenance selection looks like the method used for self-fertilizing crops (ear-to-row) when the important characters can be observed before flowering, i.e. before poor plants can contaminate the selected ones. When important characteristics cannot be observed before harvesting (e.g. seed colour in sesame) the remnant seed method presented above for cross-pollinators can be followed, to increase efficiency. There is no need to observe the minimum number of selected plants in this type of crops, because inbreeding depression is less likely. As with self-fertilized crops, however, selection of less than 10 plants should be avoided.

Conclusions

Farmers apply very different types of selection in their crops as part of their seed production processes. Varying levels of selection pressures and use of diverse criteria over many generations have resulted in the farmers' varieties that we know today. Maintaining the positive traits and improving on less desirable ones are important

objectives in local seed management, which may benefit from various methods of maintenance selection derived from the formal seed system. The resources and knowledge of farmers, and their priorities with regard to their varieties largely determine which methods are most appropriate for their conditions.

2.2 Supporting farmers' practices in seed processing and storage*

Niels P. Louwaars and Conny Almekinders

Post harvest operations and storage methods have strong effects on seed quality. This section introduces general aspects of these operations, such as handling, seed drying, cleaning, treatment and the effects of temperature, moisture, and insects on the potential loss of seed quality during seed storage. These aspects can be taken into account when assessing and seeking ways to support farmers' methods of seed processing and storage.

Harvesting

Harvesting should be well timed to allow quick drying of the seed, and to avoid important losses due to shattering or field infestation of storage insects (e.g. weevils in maize, bruchids in faba bean). Farmers often delay harvesting because of the peak labour needs at the end of the season, and because drying of the crop on the plants reduces the need for drying floors. Harvesting and threshing have to be done with much care to avoid damaging the seed. Threshing when the seed is over-dried may cause the seed to crack, while threshing wet seed may cause (internal) damage and create subsequent germination and vigour problems.

Processing

Processing is the first post-harvest activity in farmers' seed management. It includes activities such as handling (transporting/receiving), seed drying, cleaning and treating.

Drying

Seed should be dried quickly, but high temperatures can damage the seed. Sun-drying can normally be completed in a few days. For some crops, such as maize or sesame, special racks or cribs are used to improve the ventilation and speed up drying. If seed is dried on the floor, regular turning will improve the balanced drying of the seed lot and avoid mould growth at the bottom of the layer. In humid climates, seed drying can be a serious problem. If harvesting cannot be done during a dry season, small scale wood-fuelled dryers can be used. These require a considerable investment and

* This section is adapted from Almekinders, C.J.M. and N.P. Louwaars, 1999. Farmers' seed production. New approaches and practices. London, Intermediate Technology Publications: pp. 112-118.

experience has to be obtained to avoid over-heating of the seed. The effect of high temperature is most damaging when the moisture content of the seed is high.

Cleaning

Seed cleaning has a dual purpose: it removes non-crop seed materials from the harvested material, such as straw, stones and weed seeds, thus reducing the bulk to be stored; and it also selects the seeds on the basis of physical characteristics such as size, shape, density and colour, thus removing small and shrivelled seeds and improving the seed quality.

For most crops, seed cleaning is no different to the cleaning of food grain for consumption, so that local methods for cleaning food grain are well suited for seed cleaning. Such methods include winnowing, sieving and hand-picking. Winnowing removes the light particles like straw and dust, and it can be used to remove seeds with a low density (low weight per volume: empty or 'soft' seeds). Sieving selects the seed on the basis of shape and size. Hand-picking is used to remove diseased and discoloured seeds. See Box 2.5 for an example of how seed selection and cleaning may positively affect on-farm seed production.

Box 2.5 Improving on-farm seed production of millets

An NGO operating in West Africa collected some samples of millet during a diagnostic survey in a low rainfall area. Unlike modern varieties, the traditional millet varieties were well adapted to the length of the growing season and the farmers' culinary preferences, but plant stands in the field were very variable. The collected samples were analysed. The proportion of small and damaged seeds was considerable. After removing these seeds, two samples of 200 seeds from each collected seed lot were germinated: one sample using a test called the 'rolled towel test', and the other using a calabash containing moist sand.

Results of the analysis were discussed with the farmers from whom the seed had been collected. Farmers showed an interest in carrying out the simple seed testing in a calabash filled with moist sand. Individual farmers and NGO technicians also decided to mark out a 20 x 20 m seed plot in the centre of their field where they thinned the millet to one plant per mound and removed diseased plants. At harvest they used the criteria of colour and vigour to select plants for seed which were disease free, high tillering, and had many medium to large heads. Utilizing the harvested seed and the sieving method, farmers realized a 30% yield increase in the following year. Other farmers were informed through group meetings where the individual farmers were invited to relate their experiences. In 1992, 50 farmers in 5 villages produced 850 kg of seed.

When (women) farmers pick their bean seeds just before planting, they can easily remove discolored seed due to disease infection. The chief limitation of hand-sorting seeds is, however, the time it takes. Relatively small seed-cleaning machines (0.5 t/hr) are available, but their cost and their dependence on electricity are prohibitive in many cases, and such an investment should be considered very carefully for the relatively small quantities and time period involved (compared to grain).

Treatment

After cleaning, the seed may or may not be treated, depending on the local need to control plant pests. Chemical seed treatment has become routine practice for many crop seeds in formal seed systems, and increasingly also in farmers' seed production, and is seen as offering the cheapest, safest and most efficient form of plant protection. Farmers often use chemicals in powder form, first diluted in water and then mixed with seed manually on tarpaulins using shovels. However, the main constraints for seed treatment include problems related to: availability; methods and rates of application; safety precautions; lack of adequate equipment and knowledge. Good extension programmes for seed treatment would help farmers to use chemical treatments more effectively, targeting the organisms and reducing costs and environmental pollution. It would also be helpful to provide hand operated or mobile seed cleaners, and to make sure that seed is bagged in clean bags without insects or leftover seeds from the previous harvest. To avoid mistakes, seed bags must be labelled.

Storage

The main enemies in seed storage are high temperature and moisture, which affect the maintenance of seed quality in storage. Table 2.1 gives approximate periods that seeds of a number of crops can be stored under given seed moisture conditions. Additionally, high temperature and moisture favour the development of insects, bacteria and fungi. Table 2.1 can be read as follows. When pearl millet seed with a germination percentage (viability) of 90% is stored during a rainy season (high humidity of the air, e.g. 75% and 24°C) the viability will drop to 70% within two months. If however, the seeds can be packed in a moisture-proof container after thorough drying just after harvesting, resulting in a humidity of 45% inside the bag, they will still be viable after 13 months of storage (first column). A similar result could also be obtained by reducing the storage temperature to 8°C (but this is impractical under farmers' conditions).

Storage structures and practices should also protect the seed against damage by rodents. Storage structures for food grain are often designed for the same purpose. Temperature can be difficult to manipulate, beyond such measures as avoiding stored seed being exposed to direct sunlight or to heat under a corrugated iron roof. Traditional storage structures, such as those using mud walls or underground spaces, are often well-designed and provide efficient isolation to keep temperatures moderately low.

Ideally, airtight containers are used to store well-dried seed. This is feasible for small quantities of vegetable seeds, but not for bulky field crop seeds. For vegetables, various glass jars are used, such as soda bottles sealed with candle wax. In some countries, 50 kg bags of laminated polythene/aluminium foil are available; in other areas, multi-layer polythene-lined oil drums are used. Airtight containers also solve possible insect problems because the insects suffocate as soon as the oxygen in the container is used up. This process can be speeded up by making sure the containers are well filled, or by filling any remaining space with inert materials such as sand or ashes to reduce the volume of air and restrict the movement of insects. Projects in

which small low-cost aluminium tanks were designed and locally produced have successfully improved maize seed storage in Central America and other places.

Table 2.1 Storage ability of different crop seeds

<i>Crop</i>	<i>Length of safe storage at 24°C (months)¹</i>		<i>Maximum temperature for one year storage (°C)</i>	
	<i>RH=45%</i>	<i>RH=75%</i>	<i>RH=45%</i>	<i>RH=75%</i>
Barley	19	2	27	10
Pearl millet	13	2	24	8
Rice	13	3	24	11
Wheat	6	1	20	0
Rape	28	4	29	15
Pea	37	3	32	15
Bean	67	12	37	15
Cowpea	39	4	33	14
Broad bean	70	15	36	25
Groundnut	11	1	23	-
Soybean	17	2	26	10
Cabbage	23	4	30	17
Onion	13	1	23	10
Lettuce	35	3	30	15

¹ Calculated with the 'Seedlife' programme, developed by Plant Research International, (Wageningen, the Netherlands). The following conditions are assumed: germination before storage 90%, germination after storage 70%, no insect damage.

It is extremely important that seed in airtight containers is dried very well before the container is closed, especially when the storage season is warm and humid. Some respiration will occur, thus increasing the relative humidity (RH) in the container. This problem can be reduced by placing layers of fresh charcoal in the container, separated from the seed by newspapers. The charcoal absorbs the humidity. In most cases however, seeds have to be stored in ordinary gunny bags or in bulk. In this case, good storage conditions are very important: cool, dry and free from insects or rodents.

The storage of the seed also needs to be safe from theft, and from fire and other calamities. Grain stores are generally rather well protected from rain and rodents (e.g. setting rat traps at the poles under the store). Hollowed-out gourds are sometimes inverted over hanging seed ears to provide protection against rodents. In Mali, small amounts of cucurbit seed are protected by mixing them with cattle dung or mud and plastering the cake formed onto a mud wall under a roof.

Seed is also often stored in the house for even better protection and for safety. An exceptional storage method is the hidden underground store used in some parts of Ethiopia and the Middle East. These stores have proven safe even after displacement of farmers during civil unrest. Storing seed ears in the kitchen hanging in the smoke of the fire is not only a safe place, but also keeps the seed dry and reduces insect and disease damage.

Generally, farmers have local knowledge of treatments for protecting seed during storage using ash, sand and plant extracts, for example. Mixing beans with ash is reported to reduce damage by bruchids and other insects. The ash damages the cuticle of the insects, causing them to dehydrate. Ash should be added in sufficient quantities: 25-50% by volume is recommended, and the addition of lime and diatomaceous soils improves the effectiveness of the protection.³¹ Vegetable oils, such as for example soya oil, can be used as a dressing to reduce insect damage. Damage by bruchid and *Acanthoscelides* is reduced by mixing 5-10 ml of vegetable oil to 1 kg of beans.³¹ In Northern Ghana cowpeas are mixed with shea butter oil and left in the sun as protection against bruchids.³²

Various plants and plant extracts are used in different parts of the world, such as crushed seeds or leaves of neem, eucalyptus or lantana. It must be borne in mind however, that natural substances may be as toxic as chemical biocides and should also be treated with care. For insect control, application of chemicals can be very effective.

2.3 Community seed banks: experiences from Tigray in Ethiopia

Trygve Berg and Fetien Abay

Community Seed Banks (CSBs) were set up in Tigray in northern Ethiopia during times of war. CSBs were first developed in 1988 as a response to hardship and famine, and from 1991 they were seen as instruments of post war recovery. During the 1990s, with the situation gradually returning to normal, government services entered agricultural development. They provided farmers with 'packages' of improved seeds and fertilizers. Since then, government seed supply services have changed and the influence of the private seed sector has grown.

Traditional seed selection is in decline in many communities in Ethiopia, and not all farmers have physical or economic access to certified seed. Therefore, alternative approach towards seed supply offered by the CSB deserves careful examination.* In this section, we aim to respond to a number of questions aimed at assessing the impact of CSBs on the informal seed system. Our leading questions are: Is it possible through CSBs to revive and strengthen farmers' culture of seed selection? Could CSBs and a revived culture help to improve the quality of the seeds that farmers use? And could CSBs contribute to seed security and to improving the livelihood of the poorer households?

The beginning of seed banks: a community response

Collaboration and community action are common features of adaptation to crisis, including famine survival strategies. The idea of organizing seed banks emerged from

* See also Section 2.4 by Pitambar Shrestha and colleagues on community seed banks in Nepal.

community meetings in Tigray after the famine of 1984/85. People had noticed that some farmers managed the crisis better than others, in spite of equal exposure to the disaster. The farmers that could cope better happened to be known as good seed selectors; the quality of their seeds could therefore explain the differences in ability of dealing with the crisis. The seed banks mobilized the best seed selectors and used their selection skills to supply poorer farmers with good quality seeds.

Design and operation of the community seed banks

The CSBs in Tigray were established by REST, the Relief Society of Tigray. They were supported by the Development Fund and operations started in 1989. They were organized at *woreda* (district) level and operated at *tabia* (local) levels; each seed bank was governed by a seed bank committee. The committee was chaired by the representative of the local assembly. Both local seed selectors and professional agriculturalists were member of the committee. Together they identified farms with quality seed of the most popular varieties and bought seed in large quantities. They made use of the best traditional methods of seed storage and managed to keep the purchased seed well in separate stores. At a later stage, central seed bank stores were constructed. The CSB bought selected seeds for market prices at the time of harvest and distributed seeds to the needy farmers on favourable credit terms at the time of planting. Loan takers had to pay back in cash after harvest, at a low interest rate. The idea was to recover the money that had been spent and use it for the purchase of new supplies of selected seeds for the following year. The interest was meant to cover operational costs, so that the initial capital could be maintained as a revolving fund. With the maintenance of a revolving fund, the seed banks functioned economically as credit institutions; they put the real capital, the seeds, into effective circulation. However, losses occurred in years of drought and crop failure, so the donors had to replenish the capital from time to time.

Seed quality and crop performance

During interviews with farmers, they expressed an awareness that crop performance depends on good seed selection. When asked what would happen if they stopped selecting seeds, farmers unanimously responded that the seed quality would gradually become poorer and that yields would diminish. Farmers do have the capacity to maintain the quality of the varieties. Research in the area identified selectors and non-selectors. As a group, selectors produced better in terms of both crop yield and household food security.³³ Areas where farmers depend on saving their own seed, their consciousness of the importance of seed selection practices affects crop performance positively.

Farmers' seed selection practices*

It is difficult to give an account of who the seed selectors are and how they work. Only a few farmers carefully conduct seed selection. The most common method is

* For more background on selection practices, see Section 2.1 by Conny Almekinders and Niels P. Louwaars.

simple mass selection, which tends to lead to the most fertile patches of the farm. Chosen plants may be vigorous and with physiologically well-developed seeds, but those plants may not be genetically different from the field average. However, some farmers practise more systematic and sometimes surprisingly sophisticated forms of mass selection. One example of a more systematic approach is known locally as *mingas*, meaning ‘making king’: a system of two-year cycles of selection that is mainly applied to wheat and barley. In the first year of the cycle, individual plants are carefully selected from all over the field. Those seeds are bulked and planted for multiplication on the most fertile land available, which is also given manure and special attention. The same field is bulk harvested without selection. The next year the seed is planted in the larger fields, selection is performed and the procedure is repeated. Another practice is not to look for the best overall plants, but for those which are vigorous relative to surrounding plants. This procedure resembles the ‘grid selection’ described earlier in Section 2.1. These more systematic and intensive forms of mass selection ensure continuous adaptation of varieties when conditions change. Seed selectors have found that their selected seeds are more responsive to the better growing conditions on terraced fields and fertilized land. These experiences confirm that traditional seed selectors can provide seeds of better quality than the average quality of local seeds, and that the benefits of such farmer-selected seeds can be extended by means of CSBs.

Using seed selectors’ skills in supporting seed supply

The seed bank activities in Tigray have convinced farmers of the importance of seed selection. An increasing number of farmers are now practising some kind of selection. In a *woreda* where the seed bank had been closed, farmers told us that most of them started their own seed selection when the seed bank stopped. A practice encountered in many developing countries is that although farmers do grow modern varieties, predominantly of their main staples, seed replacement rates are low. Farmers are used to recycling their seeds. Varieties may become mixed and may lose their distinctive characteristics. With inadequate capacity to solve the problem through large-scale distribution of certified seed, variety rehabilitation through support to local seed selection could be seen as an alternative. With proper instructions and support, farmers can rehabilitate ‘degraded’ varieties in just a couple of crop seasons. Farmer seed selectors are usually open to sharing knowledge and seeds with others. They are eager to learn from their own experience and through discussions with other farmers and outsiders. They are not mere custodians of culture and tradition. They are generally more open to innovation and change than non-selectors in the same communities. They could be points of connection for the introduction of new varieties, ideas and skills, and could help distribute improved seeds in the communities.

Community seed banks and genetic resources conservation

The CSBs were established in times of hardship and famine, based on local initiatives. Farmers identified the problems and possible solutions that would make use of their own genetic resources, and knowledge and skills that existed in their communities.

Professionals working for local NGOs were involved in the organization, and foreign donors provided the capital. The CSBs opened a channel through which new varieties, good quality seed, technologies and skills could be introduced.

The CSBs have contributed to the survival of landraces by keeping them viable and competitive. The genetic resource base is maintained in communities where the seed banks are operating. Since the seed banks operated independently at several local levels, the set of varieties offered differed from one seed bank to the next, adding up to very high numbers of varieties per district or zone. Various studies indicate that no genetic erosion is taking place in areas where the seed banks have been operational.

Farmers' Rights are defined by the FAO as 'rights arising from the past, present and future contributions of farmers in conserving, improving, and making available plant genetic resources, particularly those in the centres of origin/diversity'. CSBs provide a strong case for Farmers' Rights, contributing to the conservation and use of landraces, as a living, dynamic and vibrant feature of current farmer activities. Those who fight for Farmers' Rights against the strong forces of monopolization of seeds through patent systems may see an excellent case and find strong arguments for Farmers' Rights in the activities of CSBs.

The future

Based on our experience and years of following the CSBs in Tigray, we find it important to strengthen the CSB capacity to multiply seed on farmers' fields. We would also encourage the involvement of private investors, farmers, and support the promotion of joint ventures/cooperatives in seed production and marketing. It is essential to associate seed production and marketing with applied plant breeding and seed research. We need to document existing potentials and introduce variability for demanded traits or crops. We foresee that the CSBs will survive if they can provide the seeds that are needed and demanded, and if they can be operated as commercially viable enterprises.

2.4 Community seed banks: experiences from Nepal*

*Pitambar Shrestha, Bhuwon Sthapit, Pratap Shrestha,
Madhusudhan Upadhyay and Mahanaryan Yadav*

Nepal, situated in the Central Himalayas, is a country of both physiographic and climatic contrasts. It is divided into five ecological regions – high Himalayas, high mountains, middle mountains, *Sivalik* (between *Tarai* and mountains) and *Tarai* (lowland). The climatic conditions range from tropical in the south to freezing alpine

* This section is adapted from Sthapit, B.R., P.K. Shrestha and M.P. Upadhyay (Eds.), 2006. Good practices: On-farm management of agricultural biodiversity in Nepal. Kathmandu, NARC, LI-BIRD, IPGRI and IDRC.

in the north. Extreme variations in altitude, topography and climate and a long agricultural tradition have contributed to an immense genetic diversity in the form of traditional crop varieties.

About 81% of the people rely on agriculture for their livelihood. Landholdings are small and fragmented, usually less than one hectare per household with 5.6 people per household. The economy is largely based on intensive use of natural resources which has resulted in environmental problems. Farmers are vulnerable to natural disasters like drought and floods which cause erosion of plant genetic resources. The challenge for the government of Nepal is to create incentives for maintaining a biodiversity that benefits farmers today as well as tomorrow.

Description of the site

Kachorwa is a small village of 914 households in the Bara district. It is located in the central *Tarai* region on the low-lying, flat and fertile Indo-Gangetic plain. The agro-ecosystem is sub-tropical with an altitude of 80-100m ASL and an annual rainfall of 1515 mm. Rice is the most important staple crop, and is rich in intra-specific diversity. Its production is semi-commercial and dominated by modern varieties; few farmers grow local varieties. Farmers in the area have ample access to inputs, modern varieties and technologies, and have good market opportunities. The pressure on farmers who grow local varieties is considerably high. Local varieties are fading away with the preference for high yielding modern varieties.

With high technological intervention and easy access to inputs, farmers in Kachorwa are replacing traditional local rice varieties with popular modern varieties with strong market demand.³⁴ Of the 33 local rice varieties inventoried in 1998, only 14 could be found on-farm in 2003. The number of growers of local varieties decreased from 68% to 32%; and the total area occupied by local rice varieties decreased from 17% to 3%. Because of this alarming situation, staff of a research and conservation NGO encouraged farmers to establish a community seed bank with the aim of conserving the local varieties within the community, through improving access to local variety seed and supporting the community-based seed system.*

What is a community seed bank?

Community seed banks (CSBs) are established to conserve local varieties through a farmer-led on-farm conservation approach. In the CSB, seeds of local crop germplasm are collected, together with important associated knowledge and information. Seeds are regenerated or multiplied and distributed to farmers upon request. CSBs are locally managed and therefore provide easy access to and control over planting materials. The local varieties continue to evolve and adapt to the local agro-ecological habitats. Thus, the overall purposes of community seed banks are to:

- Establish a local contact point for local seeds and associated knowledge and information;
- Improve access to farmers' seeds of local varieties at the community level;

* See also Section 2.3 by Trygve Berg and Fetien Abay on community seed banks in Tigray, Ethiopia

- Document knowledge of traditional varieties and maintain small amounts of seeds; and
- Promote on-farm conservation through community-based conservation actions.

Methodology

A CSB is a community-managed approach that expands local practices from the household to the community level. Establishment and success of a CSB is dependent upon the interest and level of awareness of the local community on the importance of agrobiodiversity. The following steps and processes were employed for the establishment of the CSB in Kachorwa village.

1. *Community sensitization*: Genetic erosion of local varieties was taking place due to high technological intervention, high access to inputs and frequent natural disasters like floods and drought. A community biodiversity register was established and a diversity fair* was held, and they confirmed the alarming rate of genetic erosion at Kachorwa village. The farmers realized the need for conservation of local rice varieties.

2. *Strengthening local institutions*: Empowerment of farmers and community-based institutions were considered as key to successfully implementing the CSB approach. Community members were organized in a local institution and trained on group management as well as CSB management. Topics addressed were conceptual and practical aspects of seed handling and storage, including the maintenance of a community biodiversity register, multiplication practices of traditional seed, and maintenance of small quantities of seed in traditional seed storage structures. The users of the CSB were advised on seed quality maintenance and seed return during seed distribution and before harvest.

3. *Development of rules and regulations*: Based on community interest rules and regulations regarding the mechanism for seed collection, regeneration, quality control and distribution were formulated, and roles and responsibilities of CSB members in seed management were defined. To increase sustainability, decisions were made in accordance with the local context, customs and values.

4. *Construction of seed storage facilities*: Traditionally, farmers store seed in local seed storage structures such as *Mor* (made of rice straw), *Ghaila* (made of mud), *Kothi* (made of mud and bamboo), *Chaintha* and *Mouna* (made of bamboo). For the CSB similar storage structures were used, which means that no ‘external’ technical knowledge was needed to build and maintain the facilities. Contributions from local people were encouraged in order to build ownership and make management of the CSB locally sustainable.

* In Section 3.7, Bhuwon Sthapit and colleagues provide detailed information on the diversity fair and biodiversity register when describing various practices supporting community management of biodiversity.

5. *Collection of local seeds:* The CSB project identified and collected rare, endangered and threatened local rice varieties through the community biodiversity register and diversity fair. The local varieties that were grown by just a few households in small plots were carefully collected from the individual custodians. CSB members also collected traditional vegetables and other crop species from nodal farmers, neighbours, relatives and neighbouring villages.

6. *Development of options for livelihood and income generation:* A community biodiversity management fund was created to develop options for livelihood and income generation and link this with local varieties conservation. The fund was equivalent to US\$ 1050 with 33% cash contribution from the community and the remaining percentage added from a conservation project. Loans for income generation activities were provided to 25 members each year at low interest rates (12% per annum) giving priority to the poorest members of the group. One of the rules of the fund was that the members who took loans from the fund had to grow at least two preferred local varieties in a small area of their farmland (rice was compulsory, plus one other crop of choice, e.g. pigeon pea, sponge gourd or finger millet).

7. *Monitoring the impacts of CSB interventions:* The primary objective of the CSB was to conserve local varieties by creating easy access to seed and planting materials for the farmers. The indicators used for monitoring this were: a) number of farmers who saved seed for subsequent years amongst the users, b) number of farmers who distributed the seed to neighbours, relatives or other interested farmers, c) amount of money earned by farmers from the community biodiversity management fund, d) number of farmers who actually followed the rules of growing at least two crop local varieties, and e) perception of the farmers of the presence of the community seed bank in their village.

Benefits of the community seed bank

CSBs have great potential utility in areas with (i) high technological intervention, (ii) high access to inputs, and (iii) frequent natural disasters like floods and droughts. In areas with high technological intervention and with easy access to inputs farmers are more likely to neglect local varieties. In areas with frequent natural disasters, landraces are at a high risk of loss due to events like floods, etc. In these areas, CSBs can provide a viable option for conserving local varieties. What is more, local varieties are better adapted to their often marginalized environments than modern varieties. CSBs can provide a constant supply of seeds of local varieties for these environments. The benefits of having a CSB as experienced in Kachorwa village of Nepal are mentioned below.

Local seed security and on-farm conservation of local varieties

The CSB initiated at Kachorwa village is a leading example of sustainable local seed security, promoting conservation of local crop diversity on-farm. After its establishment, the number of local varieties and the overall diversity in the village have increased (see Table 2.2) and seed of local varieties has become more accessible and abundant. For the farmers of Kachorwa, the options for the choice of varieties for marginal growing environments have increased. The community seed bank has employed different on-farm seed conservation strategies: (i) providing seed to the farmers following the traditional loan system, (ii) providing seed to the community biodiversity fund users, (iii) maintaining diversity blocks of each crop and landrace, and (iv) keeping remnant stock to avoid risk of loss from natural disasters. It is important to note that the CSB collects seed grown by farmers at farmers' fields, allowing both human and natural selection.

Table 2.2 Status of local seeds conserved at the community seed bank in Kachorwa, Nepal

<i>Crop</i>	<i>Number of additional local varieties collected each year</i>				<i>Total</i>
	<i>2003</i>	<i>2004</i>	<i>2005</i>	<i>2006</i>	
Rice	19	18	17	9	63
Finger millet	2	-	-	-	2
Sponge gourd	5	-	-	-	5
Pigeon pea	2	-	-	-	2
Total	28	18	17	9	72

Table 2.3 Recipients of seed from the CSB in Kachorwa, Nepal (2003-05)

<i>Year</i>	<i>Number of farmers of different socio-economic category</i>				<i>Number of local varieties</i>	<i>Seed qty. (kg)</i>
	<i>Rich</i>	<i>Medium</i>	<i>Poor</i>	<i>Total</i>		
2005	17 (20%)	37 (42%)	33 (38%)	87	23	198
2004	6 (17%)	14 (40%)	15 (43%)	35	13	69
2003	5 (12%)	19 (48%)	16 (40%)	40	11	87

Easy access to seed of local varieties

The CSB is a contact point for accessing local seed and associated knowledge. CSB members have collected local crop germplasm and important associated knowledge. Collected seeds are stored, regenerated or multiplied and distributed to fulfil farmers' seed requirements for their diverse agro-ecologies and to promote on-farm conservation. Seeds are locally maintained and managed, providing easy access to and control by farmers, allowing traditional exchange of seed and knowledge, and enhancing sustainable management of local resources. The CSB has given priority for seed access to women group members and resource-poor farmers who are not able to save or purchase seeds due to small land holdings. Preliminary results showed that 38-43% of poor farmers have received seed of 11 to 23 local varieties during the period from 2003 to 2005. In 2003, 40 farmers used the CSB as a seed source; the number

was 87 in 2005. The seed quantity increased from 87 kg in 2003 to 198 kg in 2005 (Table 2.3).

Empowerment of farmers through on-farm conservation

The CSB in Kachorwa village is an integral part of a community-led agricultural biodiversity conservation approach which strengthened the conservation capacity of farmers. The local institution was established to manage the CSB and other community-based conservation and development activities. Farmers have established a community biodiversity register of cereal crops, vegetables, fruits and medicinal plants, through which the extent and distribution of local variety diversity is analysed, traditional and local knowledge is documented and seed production and distribution of rare and endangered local varieties is planned. The CSB is systematically managed to counter the loss of local varieties through seed collection, regeneration and distribution, and setting rules for CSB use. Six women groups were formed, along with groups of nodal and other farmers, for seed collection, regeneration and the organization of diversity fairs. CSB members continuously maintain diversity blocks of all local varieties collected, which are used to produce adequate quantities of seed for distribution. Seed drying, cleaning, and storage in traditional seed storage structures is conducted by the members of the local institution on both a paid and a voluntary basis. They conduct germination tests before seed distribution, and only seed with adequate levels of germination is distributed. This initiative has increased the capacity of farmers and has empowered them to conserve and use their own agricultural biodiversity on-farm.

Conclusion

As a community owned and managed activity, with integrated additional activities like local financial resource mobilization, the creation of a conservation fund, and other income generating activities, the CSB was found to be effective and sustainable. This approach both serves the conservation of local varieties and provides seed security to the farming community, by increasing access to genetic materials. The CSB can be managed locally with a minimum of external financial and technical support and can be integrated with other community development activities. The CSB addresses all aspects of a healthy seed system and, by allowing the evolutionary process of crop improvement to continue on-farm, increases the stability and resilience of the local agro-ecosystem. Creation of a knowledge base and community empowerment are the driving forces for the success of the CSB. However, collaboration with plant breeding programmes and agricultural research and development agencies still needs to be initiated. Such linkages can make the CSB more dynamic, allowing the introduction of new diversity that can be integrated with the existing agricultural biodiversity instead of replacing it.

2.5 Seed relief intervention and resilience of local seed systems under stress: the case of Humbo woreda in Southern Ethiopia

Asrat Asfaw, Anbes Tenaye and Endrias Geta

Ethiopia has received food and seed aid several times over the last three decades. One of the major recipients of seed aid in the past was the Southern Nations, Nationalities and Peoples Regional State (SNNPRS) in general and ‘Humbo-wolayta’ *woreda* in particular. A continuous flow of seed aid can offer opportunities and at the same time present constraints for agricultural stability. In order to anticipate future directions, it is relevant to understand the trends and the effects of seed aid on farming communities, and to assess why seed insecurity appears to persist. This section provides a short overview of long-term seed aid practices in SNNPRS and raises concerns about current practices.

Overview of seed relief interventions

In Africa, seed relief has become a routine component of the emergency efforts since the 1990s, with around US\$ 10 million spent on the procurement of seed for emergency projects.³⁵ Free seed provision to Ethiopian farmers was started during the rehabilitation programmes in the aftermath of the 1984/85 famine. For example, the Christian Relief and Development Association distributed 5,980 tons of seeds worth ETB 5.1 million. The assistance mainly focused on supplying seeds and farm tools to the agricultural households affected by stress, to help them produce their own food for short-term agricultural resilience. The process was framed as ‘developmental seed aid’.

In SNNPRS, seed assistance probably dates back to the 1984/85 famine when many areas of the present day regional state were affected by drought. Since 1984/85, recurrent drought has become a common phenomenon in many parts of the region, making crop production unstable and more dependent on external assistance. Humanitarian assistance by many governmental and non-governmental organizations (GOs and NGOs) in the region includes the delivery of seed and agricultural implements.

Provision of emergency seed aid in Humbo was probably started in 1992/93* when it was under the administration of the former zone of North Omo in SNNPRS. Accordingly, the zone implemented an emergency seed aid project to the tune of nearly ETB 2.7 million. Drought and flooding triggered seed aid; heavy rain resulted in flooding in one part of the zone while the other part remained drought-ridden. In 1997, there was another big crisis in North Omo zone due to bad weather caused by ‘El Nino’. The zonal office of agriculture obtained nearly ETB 1.5 million in 1985 for emergency seed aid operations. The largest share (nearly ETB 64,156), was disbursed to the Humbo *woreda* for seed procurement. Nearly 8 million sweet potato cuttings of

* Personal communication with experts of the North Omo Agricultural Development Office.

a local variety were distributed to 950 drought victim households. In addition, 56 households received 350 kg of seed of improved maize varieties and 50 kg of local maize varieties. Having become an integral part of the relief interventions, seed relief now constitutes a source of new seed for farmers in the area.

Seed systems under stress

Farmers may obtain seeds as planting materials from different sources, and presumably use different channels and exchange mechanisms in normal and in stress situations. Farmers' seed source in normal situations is mostly their own stock from the previous harvest. However, some households are seed secure and others are semi-secure or insecure, i.e. sometimes or always run short of seed. The importance of farmer-based seed sources and channels may decrease with increasing drought occurrence, insecurity and poverty. For many farming households, the problem of seed availability and/or access is more profound in stress situations. Seed insecurity can be classified as acute or chronic.³⁶ Acute seed insecurity is brought on by distinct, short duration events (food, drought, civil strife, etc.) that often affect a broad range of the population causing a total failure to plant in a single season, loss of a harvest, or one-time loss of seed stocks in storage. Chronic seed insecurity is independent of acute stress or disaster, and may be found among populations that have been marginalized in several ways, i.e. they are economically/socially marginal (poor, with little land and labour), ecologically marginal (e.g. subject to repeated drought, farming on degraded land), and politically marginal (in insecure areas, or on land with uncertain tenure arrangements).

Studies of seed systems in stress situations reveal that farmers' seed sourcing involves several social networks and actors. Farmers have access to and use seed from several sources of varying degrees of importance depending on the context. The farmer-based seed sources are represented by their own saving, friends/relatives, other farmers within and outside the community, and local markets. Generally, farmer-based seed sources do not totally collapse under disaster, and farmers can often access seed for at least some key crops from local farmer-based sources during crisis.^{35,37}

Analysis of seed systems in crisis situations

In relation to crisis situations, two kinds of seed system analysis have been practised, i.e. a priori and a posteriori intervention assessments. A Priori intervention assessments have been restricted to rapidly calculating seed needs so as to provide an injection of relief seed. The relief seed calculations mostly draw from crop loss assessment works. A Posteriori intervention assessments have usually been a single season exercise to calculate the delivery of outputs achieved. Rarely has an intervention analysis asked the fundamental question of whether the aid enhanced immediate agricultural resilience. Even more rarely has follow-up examined the systemic causes that prompted the delivery of seed aid in the first place.

A seed system assessment was therefore conducted in Humbo in 2006. The assessment consisted of focus-group discussions with aid implementing agencies and detailed household survey among aid recipient farmers. Both qualitative and

quantitative data were collected. Focus-group discussions involved key informants from government aid practitioners at regional, zonal and *woreda* levels, from the Bureau of Agriculture and Rural Development (BoARD), and from NGO aid practitioners based at Wolayta-Humbo (World Vision, Concern Worldwide, International Medical Corps, etc). Household surveys involved 113 farmers, eliciting their experience with seed aid, the crops and varieties used in recent seed aid events, all other seed sources used in that season, and their reflections on seed aid practice and its impact on the village's seed system.

The results of the household survey indicated that even under stress situations, farmers have access to seed from several sources (Table 2.4). The seed from relief aid covered up to 57% of aid crop 1 and 78% of aid crop 2 planted by farmers in the area. Farmer-based seed sources, i.e. own savings (home stocks) and local markets for aid crop 1 and local markets for aid crop 2 were important sources of seeds for planting, following relief seed aid. Other sources like gifts, exchange and seeds from the formal seed sector through the extension programme played a very small role.

Table 2.4 Seed sources (%) for emergency seed aid crops in Humbo *woreda* (2006)

<i>Sources</i>	<i>Aid crop-1</i>	<i>Aid crop-2</i>	<i>Both</i>
Seed aid	57	78	61
Own stocks	20	4	17
Local market	19	11	17
Gifts	2	0	2
Exchange	0.3	2	0.7
Extension (BoARD)	3	5	3

Source: Seed survey conducted in Humbo district in 2006

Discussions with key informants from GOs and NGOs, and the detailed household survey highlighted the fact that relief agencies used many types of crops, varieties and seed sources during relief delivery. During crises, seed aid providers sourced seed from local markets (local farmers and traders if there was a seed fair), research centres, national bids (bulk purchase for direct seed distribution), private seed enterprises, cooperatives and the public seed sector. The wide range of seed sources is an indicator of seed availability in times of crisis. The seed aid providers used both modern and farmer varieties (Table 2.5). For maize, an open pollinated modern variety was usually used. In case of sweet potato, though there was some controversy, the variety was considered to be a farmer variety (traditional or 'creolized' modern variety). In the case of other crops, both modern and farmer varieties were used depending on seed availability.

In the Humbo context, emergency seed delivery substantially helped meet the seed needs of the farmers (Table 2.6). The contribution of aid as a seed source varied from 42% for maize to 100% for sorghum. The present result deviates from the findings of others,^{35,37} who reported that the aid made a relatively minor contribution towards meeting the seed needs of the stress-affected farming communities. This may be due to recent changes in the seed aid implementation process, i.e. a shift from mass

targeting to more accurate targeting, which resulted in reaching the neediest farmers who lack access to other seed sources in times of crisis.

Conclusions

The way farmers secure access to seed in normal and in stress situations may differ depending on their biophysical and socio-economic contexts. Under normal situations, farmer-based seed sources, mostly own savings and local markets, are the major sources for planting. Under stress situations, farmers get access to seed in a number of ways. Relief seed provision contributes to meeting the seed needs of the farming community, but does not replace other seed sources. Seed aid has been evolving into one of the major seed sources in recent years. Local markets also play an important role as seed sources under stress situations.

Table 2.5 Percentage of modern and farmers' crop varieties used during seed aid provision at Humbo *woreda*

<i>Crops</i>	<i>% of modern varieties*</i>
Teff	54
Maize	100
Sorghum	50
Chickpea	39
Common bean	20
Sweet potato	0
Cotton	27

Note: *The remaining percentage is covered by farmers' varieties

Source: Seed survey conducted in Humbo district in 2006

Table 2.6 Seed relief contribution to seed needs for different crops at Humbo *woreda*

<i>Aid crops</i>	<i>Seed aid as % of total planted</i>
Teff	95
Maize	42
Sorghum	100
Chick pea	85
Common bean	90
Sweet potato	51
Average	60

Source: Seed survey conducted in Humbo district in 2006

Seed provision to farmers in Humbo is of two kinds: developmental seed aid and emergency seed aid. Developmental seed aid includes popularization and demonstration of improved crop production technologies, taking seed as the core element to improve the livelihood of the people in marginal food insecure environments. Chronically food insecure households are the main beneficiaries of

developmental seed aid initiatives. Emergency seed aid includes mass distribution of seeds to a large number of farmers affected by short-term natural calamities like drought and flood. Drought is the major trigger of emergency seed interventions in Humbo.

Seeds are delivered by seed aid practitioners in Humbo through direct seed distribution, seed fairs and vouchers. The study revealed that no seed need assessment has been conducted as such and no organized periodic monitoring and evaluation of seed aid distributed to farmers has taken place. Instead pre- and post-harvest crop assessments are used as a means of evaluating field performances. Seed aid has both positive and negative impacts on agricultural stability. Both farmers and practitioners agree that seed aid positively contributes to agricultural stability by providing new varieties and crops. On the other hand, there is a shared concern about the danger of seed aid creating a dependency syndrome and eroding a long-existing tradition of seed selection and conservation. About 25 percent of the farmers interviewed during a survey assessing the impact of seed aid in Humbo explicitly indicated that their tradition of seed keeping has been affected by continued supply of seed through aid. For many practitioners, seed assistance to vulnerable populations is based on the notion that communities affected by catastrophes like drought should have basic seed as soon as possible so as to speed up the process of agricultural recovery. However, attention should be paid to basing the seed relief on actual seed need assessments and to delivering that seed to farmers as quickly as possible.

2.6 Reaching farmers in remote areas with improved bean varieties: lessons from Uganda

*Losira Nasirumbi, Jean Claude Rubyogo, Michael Ugen,
Annet Namayanja and Gabriel Luyima*

Introduction

Beans (*Phaseolus vulgaris* L.) are an important food and cash crop in Uganda. The crop is predominantly produced with low external inputs by small-scale farmers. In 2005, the area under beans was estimated at about 899,000 ha with annual production of 549,000 tons and an estimated grain yield of 617 kg/ha.³⁸ In recent years, farmers are increasingly looking for improved varieties which meet specified or differentiated bean market demands and/or varieties which are adapted to ever changing agro-ecosystems, e.g. decreasing soil fertility or increasing problems of pests and diseases. The Uganda National Bean Programme (UNBP) has released a considerable number of varieties adapted to both wider and specific agro-ecologies. The challenge was to ensure that these varieties become known and accessible to end users.

Beans are a predominantly self-pollinated crop; this allows farmers to reuse seeds from their harvest without worrying about genetic deterioration. However, this situation deters commercial seed companies from investing in the production and

marketing of bean seeds of improved varieties. Uganda has six seed companies, but their annual bean seed supply represents only about 6% of the total national requirement. Major customers are GO and NGO relief agencies carrying out humanitarian operations within Uganda and neighbouring countries. Knowing the limitations of the formal seed sector, researchers and other development partners have become interested in finding more efficient and sustainable approaches to increasing the availability and accessibility of seed of improved and preferred bean varieties. This strategy combines the strengths of participatory variety selection (PVS)* and decentralized, farm-based seed production and supply. This section shares experiences of the Uganda National Bean Research Programme with applying this combined approach.

Demand for improved bean varieties

The demand for specific bean varieties by farmers has increased for two main reasons. First, bean consumers and the market are increasingly looking for specific varieties which meet preferences such as short cooking time, taste or colour. These high value traits are embedded in the varieties' genetic make-up. Secondly, the intensive use of agro-ecosystems leads to a decreased soil fertility, higher disease and pest pressure, etc. This situation has compelled farmers to look for varieties that tolerate these conditions or offer an acceptable yield with minimum inputs. To respond to the challenges, the UNBP embarked on research geared to meeting these demands and developing varieties with a wider or more specific adaptation, and varieties that meet specific preferences. The released varieties include K132, NABE 2, NABE 4, NABE 11, NABE 12C, NABE 13 and NABE 14.

Seed supply of improved varieties

Formal seed sector

Despite the increased demand, the commercial seed sector supplies a limited quantity of bean seeds. In 2005, the sector supplied about 3,600 tons of certified seed, which represented less than 6% of the national requirement. The commercial seed sector's clients were not small-scale farmers but relief agencies buying seed in bulk. More often, these agencies operated in neighbouring countries. This limited supply is related to the severe market constraints that make multiplication and supply of this self-pollinating crop commercially unattractive; once farmers have got hold of new varieties, they re-use their seeds.³⁹ Farmers rarely express a need to replenish their seed stock unless a disaster occurs or a new variety appears. Furthermore, the formal sector mainly supplies two varieties (K132 and NABE 4) which are the most preferred by the bean consumers. There is a long time lag between the release of a variety and its popularization. The UNBP and other players should take steps to popularize the varieties before commercial seed companies start to produce their seeds. Even though the commercial sector supplies only small quantities of seed, it does play a major role

* See Chapter 4 for more background on participatory variety selection.

in the dissemination of stocks of seeds of specific varieties among farmers and subsequently in the local market.

Steps towards an integrated approach

To diversify and complement existing efforts and strengthen links in the technology development and transfer process, the UNBP established a partnership with various NGOs, local government and farmers' organizations. The multi-stakeholder partnership facilitates local production and dissemination of newly released bean varieties. It involves activities which are shared among stakeholders based on their strengths (see Table 2.7).

Table 2.7 Stakeholders analysis: promotion of improved bean varieties in Uganda

<i>Stakeholder</i>	<i>Focused roles and responsibilities</i>
Uganda National Bean Research Programme (UNBP)	<ul style="list-style-type: none"> • Variety development • Production of breeder/foundation seed • Provision of information on new varieties • Support for seed production skills and knowledge enhancement
CIAT ¹ /PABRA ² and Bean Networks (ECABRN ³)	<ul style="list-style-type: none"> • Provision of potentially promising germplasm to UNBP • Support for skills and knowledge enhancement related to seed system strengthening/business skills • Support and backstopping in monitoring and evaluation
Local extension services (government, NGOs, community-based organizations and farmer associations)	<ul style="list-style-type: none"> • Decentralized testing of varieties • Decentralized seed production • Community mobilization • Local skills building (e.g. in enhancing seed quality) • development of variety promotional materials • Development and/or translation of training manuals in local languages
Farmers (individual/groups)	<ul style="list-style-type: none"> • Testing of the potential genotypes • Carrying out local seed production and supply/marketing of locally preferred genotypes
Local seed traders	<ul style="list-style-type: none"> • Linking local seed producers with wider bean seed markets, and moving varieties beyond local zones

Notes: ¹ CIAT: International Centre for Tropical Agriculture; ² PABRA: Pan Africa Bean Research Alliance; ³ ECABRN: East Central Africa Bean Research Network

The joint activities include:⁴⁰

- An assessment of farmers' needs through participatory interactions;
- A search for suitable varieties to address these needs;
- On-farm participatory variety assessments, involving farmer groups and local extension service providers;
- The involvement of individual farmers, farmers groups and other users in the selection of appropriate varieties;

- An examination of the existing seed systems, exploring the possibilities for strengthening them and for fostering new linkages;
- The dissemination of research-derived (or ‘improved’) varieties through these newly integrated seed channels;
- Strengthening of farmers’ skills in pre-and post harvest bean management;
- Strengthening of local actors’ capacities to sustain the intervention and improve dissemination; and
- The promotion of the research for development alliance by focusing on the comparative advantages of each partner and supporting a co-learning process.

Elements of the process for establishing decentralized seed systems

Generally, the process is initiated through a series of consultations among partners. Planning and review workshops are organized at district and sub-county levels to strengthen the partnership and linkages. The meetings involve representatives of the key partners and external stakeholders. These partners play a very instrumental role in expanding project activities to other areas.

UNBP carried out ‘training of trainers’ on pre- and post harvest management (agronomy, pest and disease control, seed post harvest handling, seed marketing, group dynamics, management etc.) at district and sub-county levels. In 2005/2006, training workshops were held in various districts, enabling a total of 105 participants to share their experiences. The partners involved also trained farmer groups that they work with. Sub-county training sessions are farm-based to facilitate both female and male farmer participation, and more importantly, to enhance trainees’ practical skills. Partner organizations continued strengthening the capacities of seed producers and their group members.

To increase the popularization of improved bean technologies, promotional activities have been carried out. Farmers have been exposed not only to improved production technologies, but also to bean production management technologies, through participatory demonstrations, field days, exposure/exchange visits, participation in agricultural shows and promotional materials. For instance in 2005, participatory varietal selection type trials with released bean varieties (bush and climbers) were set up in farmers’ fields in 66 sites in three districts. In collaboration with the districts’ extension services and other local partner organizations, local seed producers were responsible for the plots. During field days, beans programme scientist, technicians, community members, district officials and other partner NGOs visited the trials.

Linking participatory variety selection to seed multiplication

Exposing farmers to new varieties increased their experimental capacities with regard to varietal selection. Farmers are able to identify best bean varieties suitable for the different crop seasons and uses (market, households etc.). A farmer from the Tusitukirewamu seed producers group in Mpigi district indicated that his group preferred NABE 4 because of its drought, pest and disease tolerance. The variety’s observed qualities were its cooking time, taste, soft seed skin and large grain size, which are preferred in the local area and market. Farmers decided to engage produce

and supply this variety. Farmers obtained access to the climbing bean variety NABE 12C and were happy with its grain qualities (consumption and market attributes) and yield. However, they indicated that staking materials would be a major problem in the production. Other farmers who usually preferred planting only small seeded varieties were surprised with the performance of the large seeded varieties in the demonstrations. They selected NABE 4, NABE 5, K132 and NABE 12C because of their yields and resistance to diseases, pests and drought. Farmers started to produce large seeded varieties, but with improved agronomic practices such as timely planting, use of rows and mono-cropping.

Local seed production

Once preferred genotypes were identified by the farmers, partner organizations secured foundation seed of those varieties from the UNBP. The intervention in the three districts involved 89 seed producers from nine groups who were able to produce and supply 71,872 kg of farmer seeds of acceptable quality, largely of eight selected bean varieties (K131, K132, NABE 1, NABE 2, NABE 4, NABE 6, NABE 11 and RWR 719) over a period of four years (2003A – 2006B). Yet the formal seed sector supplied only two varieties, i.e. K132 and NABE 4. Bean seed production activities were carried out collectively or individually under the leadership and management of elected leaders. The groups established an internal monitoring and evaluation system to ensure proper implementation of group activities. Farmer seed producers sold seeds to other farmers within the communities and to any interested group or institution within and sometimes beyond their district. Using an average purchase of 6.0 kg of seeds per household as recorded from farmer seed producers, the amount of seeds marketed in the three districts may have reached almost 12,000 households in four years. It was observed that when a variety was still new, the seed was sold at one and half times the grain price. Once the variety became widely grown, farmers got seed from the local market at grain price. Since farmer seed producer groups became involved in participatory variety selection, varieties that responded to site specificities and local farmers' preferences have also been produced and made available to farmers.

Benefits from farmer-based seed production

The impact of the programme ranges from knowledge and skills enhancement to improved incomes. Farmer seed producers expressed their satisfaction with the intervention. Through the sale of seeds, farmers were able to generate income. This considerably improved the livelihoods of the resource-constrained farmers and facilitated the development of other rural agro-enterprises as farmers have invested the revenues into other businesses. For instance Mrs. Aidah Abia, Chairperson of the Balla Women and Youth Bean Seed Producers group stated that bean seed production has changed her life. She emphasized that her income increased through the sale of beans, allowing her to send the children to school, meet medical expenses and purchase household items such as paraffin and soap. Mr. Michael Adeka Ogweo, a member of the Balla Women and Youth Seed Producers' Association used the proceeds of bean seed sales to purchase bricks, cement and pay labour for the construction of a permanent house. His counterpart from the same group, Mr. David

Abila, was pleased with the performance of the seed producers group and says “Bean production enabled us to increase incomes. I have purchased a piece of land and bought ox plough and oxen for land preparation” Mr. and Mrs. Etyak Benedict of the Momot Atwero Beans Seed Producers’ Association, were happy with the benefits they derived from the sale of bean seed as a group. They started building a permanent house to replace the grass-thatched house they had lived in for years. Mrs. Mary Kasangaki of the Akollo Women group was happy as she could now send her children to school, in addition to purchasing two goats which gave birth to five. Other achievements include the availability of beans for consumption throughout the year, purchase of pigs and goats of improved breeds, building stores and improvements in sanitation. The purchase and use of oxen and ox ploughs greatly reduced labour needs in land preparation and planting, further contributing to increased bean productivity.

Lessons learned

Small-scale farmers were willing to pay a premium price for seed of new bean varieties of their choices; however, the seed prices could not cover the actual costs of production and delivery under a formal centralized system. Similar findings were also observed in the Great Lakes region.⁴¹ Considering that PVS preceded the farmer-based (decentralized) seed systems, this process gave farmers a chance to increase the availability of seeds of the varieties of their choice – which were often site specific. Since formal and farmer-based seed production target dissimilar markets and supply distinct varieties, it is useful to engage both formal and decentralized systems because they are complementary and together reach more farmers. It may be necessary to repeat seed supply over several seasons in the same localities before a new variety is fully established within the local seed networks and markets and accessible to many farmers as grain. PVS coupled to variety demonstration gave farmers information about varieties (number of days to maturity, resistance to disease, yield, cooking time relative to popular varieties and other important characteristics). This gave confidence to seed producers who informed other farmers, becoming local extension agents. Engaging partner organizations in the decentralized seed production reduced the costs of dissemination and the work load of researchers. The time lag between variety release and farmers having access to its seeds was reduced considerably. The approach also created a learning opportunity for partners and a possibility for scaling up in other areas of their interventions. Lessons learned from this scheme, which served as a pilot in three districts in particular, showed how to engage other partners in the scaling up of the activities. A similar scheme will be used in the other 20 districts where requests for comparable interventions have been made. Decentralized seed production and supply provided an opportunity not only to make quality seeds of improved and preferred bean varieties more accessible in the targeted communities, but also to enhance the socio-economic welfare of seed producers. The wider impact on communities is yet to be determined.

2.7 Smallholder farmers' participation in legume seed supply in Kenya*

Mary W.K. Mburu, Richard B. Jones, Said N. Sillim, Fred Ogana, George A. Odingo and Johnson W. Irungu

Reliable production of high quality legumes requires a regular supply of quality seed. Most smallholder farmers rely on informal seed supplies (own-saved seed, purchases from local markets or donations from friends and relatives) of inconsistent quality and of old varieties. This results in the production of mixed grades of inconsistent grain quality, limiting farmers' ability to target high-value niche markets. The limited development of commercial seed supply systems to market improved high quality seed of legume crops grown by smallholder farmers is a consequence of the low effective demand for seed. Private investment in new seeds, production methods and post-harvest systems is unlikely to come before the market is prepared to pay for these products and services. But introducing the market to new products and standards is difficult without adequate levels of production.

Legumes in Kenya are traditionally grown as subsistence crops; seed supply is primarily through the informal sector. They are characterized by low yields and subsequently low volumes of marketable surpluses are produced, making commercialization difficult. There are several production-related constraints which include the use of disease-susceptible and low quality seed, and poor crop management practices. Capacity building of producers, traders and processors and increased availability of high-yielding disease-tolerant varieties with traits acceptable to both farmer and the market is pivotal for sustained production.

Pilot scale research by the International Crops Research Institute for the Semi-Arid Tropics (ICRISAT) indicates that farmers are willing to pay for small packs of high quality seed.⁴² Smallholder farmers can produce high quality seed provided they have access to initial seed stocks and are trained in seed production practices and internal quality control. Development of local seed companies that can produce and market high quality seed at affordable prices offers a viable alternative to informal seed supply of orphan crops. ICRISAT has developed pigeon pea, groundnut and chickpea varieties with desirable market traits that are tolerant to both the most prevalent diseases and drought. In addition to providing improved germplasm, ICRISAT was responsible for developing a sustainable seed supply system and building the capacity of farmers for improved crop husbandry.

The objective of the Lucrative Legumes Project (LLP) was to address identified constraints from production through to market, and to develop a seed supply system capable of sustaining innovation beyond the life of the project. The project, which was funded by the United States Department of Agriculture (USDA), ran from 2005 to 2007 and was implemented by TechnoServe (TNS) in partnership with Catholic Relief

*The financial support to the Lucrative Legumes Project by USDA is gratefully acknowledged.

Services (CRS), and ICRISAT. Individual partners collaborated with a range of private and public institutions.

Project implementation area

The project was implemented in five districts in Western Kenya within the Lake Victoria basin (Siaya, Busia, Teso, Homa Bay, Suba, and Bomet) and four districts in Eastern Kenya (Machakos, Makueni, Kitui, and Mbeere). The project involved over 17,800 farmers (65% of them women), formed into 679 farmer groups. Figure 2.1 shows the project area.

Figure 2.1 Map of Kenya showing project area



Groundnut and pigeon pea are important crops in western and eastern Kenya respectively while chickpea is grown in Bomet and parts of Mbeere. Eastern Kenya produces 99 % of the country's pigeon pea (190,000 t) grain while Western Kenya (Nyanza and Western provinces) produces 59% of the national groundnut crop. Chickpea fits easily in the maize-based production systems of Mbeere and Bomet as a rotation crop that grows on residual soil moisture. Kenya is a net importer of chick pea; hence its promotion would take advantage of both local and export markets. Poverty levels are high (40-70%); over 50% of the households live below the poverty line in the target districts. Soils are infertile and most farms are low in soil organic matter, nitrogen and phosphorous. Legumes are mainly intercropped with cereals (maize or sorghum) with no external fertilizer inputs on small-sized farms (<2 ha). Collective action was the strategy used for seed distribution, capacity building and marketing with existing smallholder farmer groups. In the implementation process,

the project partners adopted a participatory multi-institutional and multisectoral approach, with several collaborators from public and private sector institutions.

Seed supply system model

The seed supply system used in the project for groundnuts is summarized in Figure 2.2. It includes farmers and their institutions i.e. groups and marketing associations, seed companies and research institutes (i.e. ICRISAT, Kenya Agricultural Research Institute) and quality regulatory bodies (i.e. Kenya Plant Health Inspectorate Services). The objective of the system is to create a demand-driven seed supply chain from the breeding and seed maintenance (by ICRISAT, Malawi) to a commercial seed company marketing certified seed to farmers through the Kenya Smallholder Farmer Investment Company (KESFIC), who in turn market seed to producer marketing groups (PMGs). KESFIC maintains two supply channels, one for seed and one for grain (not shown), which supply second and third generation seed to farmers. After this, fresh seed is once again purchased from the commercial seed company and the cycle is repeated. Groundnut is a bulky perishable crop with a low seed multiplication rate that makes it relatively unattractive for commercial seed companies, but if farmers are to access high-value markets there needs to be a system for renewing seed stocks – and changing varieties as these are developed by research – on a regular basis. The model developed combines elements of improved informal seed production for later seed generations with a formal system for earlier generations. A similar seed supply system model is used in the groundnut sector in Malawi.

Figure 2.2 Project seed supply system model

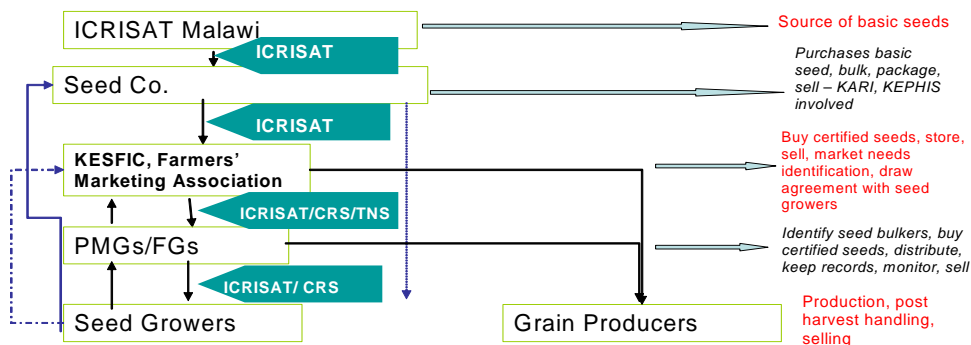

Notes: KESFIC: Kenya Smallholder Farmers Investment Company; PMGs: Producer Marketing Groups; FGs: Farmer Groups; CRS: Catholic Relief Services; TNS: TechnoServe; KARI: Kenya Agricultural Research Institute, KEPHIS: Kenya Plant Health Inspectorate.

Project outcomes

The Lucrative Legumes Project mobilized over 17,000 farmers and supplied improved legume seed to all of them over a period of two years. In turn, these farmers loaned, donated or sold the seed to non-participating farmers: a spill-over effect. The project trained over 50% of the participating farmers who demonstrated good crop

husbandry practices, value addition, group management and marketing. The farmers trained in seed production practices were contracted by a seed company to produce seed commercially. The groups were also trained in group management, which was appreciated, but the impact of the training is yet to be documented. Additionally, 11 postgraduate students participated in various aspects of crop productivity and marketing research. The farmers were able to collectively market their produce at competitive prices. They were also directly linked to grain traders. Table 2.8 presents a number of constraints and opportunities that were identified in the project.

Table 2.8 Constraints and opportunities identified in the project

<i>Constraints</i>	<i>Opportunities</i>
<ul style="list-style-type: none"> • Inadequate seed supply – small quantities of high quality seed initially available from ICRISAT and seed company; • Unreasonable farmer price expectation; • Poor distinction between grain and seed among farmers in the informal sector; • Inadequate grain volumes to sell through formal marketing channels due to home consumption; • Documentation of actual production and marketed produce difficult because farmers withhold information; • High illiteracy levels among the farmer group; members poor at record keeping; • Seed consumption as food limits expansion – however improves household food supply and saves on purchase; • Terminal drought or excessive rain necessitates fresh injection of fresh seed; • Technological limitation i.e. few groundnut shellers; • Farmers lack of patience especially when payments are delayed and when formal collective marketing is done • Short project duration – hard to consolidate the gains when the project suddenly ends; 	<ul style="list-style-type: none"> • Seed strategically distributed to “expert” seed farmers selected by each group, for multiplication under project supervision; • The seed can spread through the informal supply network among group members; • Need to train farmers on market forces and expose them to markets – through visits; • Develop or link farmers to commercial seed companies to produce certified seed; • Farmers are ready to pay more for seed if packed in small quantities and sold through formal channels; • Increase production at household level to increase volumes by increasing productivity through using improved technologies; • Develop monitoring and evaluation strategies right at the onset of the production process i.e. provide farmer-group owned record book coupled with on-farm yield assessment; • Train farmers to keep simple records; • Seed availability: capacity building can contribute to increased production at household level to increase volumes; • Commercial companies would have business opportunity; • Business opportunity to develop and market shellers and to do shelling as a business (entrepreneur identified); • Mentor and link entrepreneur to farmers and their associations; • Link farmer producer institutions to credit providers to enable payment on delivery; • Solicit donor funding to continue activities; • Link groups with public and private institutions for continued service delivery.

The way forward

An increased awareness exists among farmers of the performance of improved legume varieties. They are willing to purchase seed, which presents an opportunity for the commercialization of legume seed. The commercialization process requires interaction between the public and private sectors to formulate enabling policies for the informal seed sector, which accounts for the bulk of legume seed distribution. However a need remains to train farmers to understand business ethics, especially contractual agreements. The development of marketable legume seed, appropriate production and processing technology, and a knowledge base requires consistent investment in crop improvement research, capacity building and information distribution systems. A need exists for favourable policy and infrastructural support to improve productivity and promote the competitive commercialization of legumes.

3 Conservation and use of farmers' varieties

3.1 Agrobiodiversity, conservation strategies and informal seed supply

Walter S. de Boef

Agrobiodiversity and its conservation are highly relevant to informal seed systems, simply because these systems maintain a large amount of local crop genetic diversity. The first section of this chapter introduces biodiversity and agrobiodiversity as concepts, outlines various conservation strategies and relates these to linking formal and informal seed systems. The section elaborates how interventions in crop development (plant breeding, seed supply) can contribute to the conservation strategy referred to as 'farmer/community agrobiodiversity management' when they focus on informal seed systems and farmers' use of local varieties. Interventions which take this approach go beyond a conservation ethic to a diversity-oriented one that stimulates the dynamic use of genetic diversity and promotes the adaptive capacities of agricultural systems.

Biodiversity

During the last few decades we have begun to realise that we are losing the wealth of living forms on our planet, and that we cannot foresee what the consequences of this loss will be. Particularly in agriculture, this biodiversity is partly shaped by human activities, as we use and further develop the biological resources that we encounter. In the course of these processes, biodiversity has always evolved with continuous gains and losses. The difference now is that we realise that the balance has turned negative.

Three levels of biodiversity are generally distinguished: genetic diversity, species diversity, and ecosystems or landscape diversity. Genetic diversity can be found at the basic unit of inheritance, the DNA. It is found in the chromosomes and controls the genetic identity of all living individual organisms. Genetic diversity refers to the variety of genes in all organisms from human beings to crops, fungi and viruses. Species are organisms that are closely related, are one distinct morphological unit, and mate to produce offspring. Species diversity therefore refers to the diversity among species: different plants in a forest, fungi in the soil, fish in the river, and plant species in the garden. Ecosystem diversity is both the sum and product of the other two levels of diversity. The diversity of species and different populations within species constitute a natural community that has developed or evolved in a physical (dry, cold, wet, hot, fragile, poor or rich) environment. The scale of ecosystem diversity is important as

one square meter in a forest can be considered an ecosystem, but so can the entire Rift Valley or Indian Ocean. Ecosystem diversity is thus a relative term: it is the diversity among systems. It places that one square meter in the forest in its broader environment, and puts the Rift Valley or the Indian Ocean in the ecosystem that we call the Earth.

Biodiversity in agriculture

These terms were developed in the field of ecology, which studies the relations between the different levels of diversity. The three levels can also be applied to biological diversity in agriculture, where we can distinguish between: varietal and other genetic diversity, crop, animal and other species diversity, and farming systems or agro-ecosystems diversity.

Genetic diversity in agriculture encompasses the many varieties of crops and breeds of animals, and can be very specific (e.g. a sweet potato variety with a very specific taste and use). Genetic diversity can be distinguished using different scales. It can refer to a population or group of varieties within a species; it can be a genetic pool or population in a certain crop (e.g. an early maturing local maize variety). Species diversity in agriculture relates to the different species that we use in agriculture, covering crops, animals and fungi. But it can also mean the diversity of crops found on one farm, the diversity of cereal crops as a category, or the diversity of all food crops. So different scales apply here too. A farming system can mean one farm or an entire region. A farm in the Ethiopian Highlands has a very different level of diversity to that of the rift valley in the Awassa region or a polder in the Netherlands.

One element very strongly distinguishes agrobiodiversity from natural biodiversity. Agriculture is a way for humankind to use its natural biological and physical resources to feed itself, to cure, to construct shelter, to make clothing, and to generate income. The role of humans – farmers – in the development of diversity in agriculture is very important. Many different agro-ecosystems, crops and varieties can be found all over the world. It is not only the natural conditions which have contributed to this diversity; human diversity has contributed enormously too. Some people therefore consider human diversity, with social and cultural elements, to be a fourth level of diversity, which encompasses farmers' knowledge and practices regarding how to grow crops, their medicinal purposes, etc.

Loss of natural biodiversity

Biodiversity has never been and never will be static; it fluctuates as evolution adds new species, and extinction takes them away. Evolution and extinction are natural processes; they are the responses of populations of organisms to changes in their physical and biological environment. Change is, in a very real sense, a basic fact of life. However, the loss due to environmental changes occurring today is different in origin, order and magnitude to those recorded before. The current loss has several causes including the following:

- Direct destruction, conversion, or degradation of ecosystems result in the loss of complexes of different species;

- Over-exploitation, habitat disturbance, pollution, and the introduction of exotic species accelerate the loss of individual species within ecosystems;
- Selection pressures arising directly and indirectly from human activities can result in the loss of genetic variability;
- Exploitation, pollution or regional climate change may eliminate some genetically different parts of a population yet not cause extinction of the entire species though a part of its genetic variation;
- The accelerating rate of habitat destruction, particularly in tropical forests.

Loss of biodiversity in agriculture

Similar processes erode the biodiversity in agriculture as in nature, with humans playing a prominent role. However, humans can also play a more direct role in the maintenance of agrobiodiversity, to which they are a very active contributor. Loss of biodiversity in agriculture takes place at the three levels. Farming and agro-ecosystems change; crops are abandoned or marginalised. Most prominent in agriculture is the process we call genetic erosion, or the loss of genetic diversity.

The process of replacement of local, indigenous, traditional varieties or landraces by modern, high-yielding varieties is often equated with the loss of genes, and is called genetic erosion. However, the agricultural processes must be examined with respect to the loss of genes, gene combinations, or allelic forms. Gene replacement occurs when local varieties are replaced by introduced ones. Genetic erosion can be seen in two forms: genic or allelic erosion and genomic erosion. Replacement of landraces by new ones within a crop causes a dramatic change; there is complete replacement for those alleles which differ between the local and the new one. The replaced alleles are lost or eroded if they are not conserved, maintained or used elsewhere. Also lost is the specific combination of genes that occur in the replaced variety.⁴³

Apart from the physical loss of allelic forms, gene combinations, genes or local or farmers' varieties, knowledge about specific crops and varieties is threatened by a similar process of erosion. The development of modern agriculture leads to globalization of agricultural practices, eroding local skills for managing and using specific crops or varieties. Monica Opole⁴⁴ from Kenya in Africa refers to women in the rural area of her country who now send their daughters to school where they learn how to grow tomatoes and cabbage to be good modern mothers and farmers. Yet the mothers have started to realise that they are no longer taught about indigenous leafy vegetables, so that knowledge about important plants which are plentiful on and around the farm is gradually lost – and not only the knowledge of the species, but also the knowledge of their special medicinal and culinary properties, and ways of processing and preparing them.

Another form of genetic erosion occurs at the intermediary level in between agriculture and nature. In centres of origin and evolution, most crops still have related wild and weedy species. Where crops are grown in the direct environment of these non-domesticated species, some introgression may occur. The maize-teosinte complex in Mexico is an example of a system in which a wild relative grows in the neighbourhood of the crop. Various researchers have investigated this interaction,

looking for specific characteristics of the local maize varieties which may originate from the wild teosinte plants. Through modern plant breeding and biotechnology, all related plants to a crop species may be a source of important traits for breeding in the future. Due to destruction of specific habitats, such wild relatives of important crops may disappear.

Conservation strategies

Writers on biological conservation define it as the effort to maintain the diversity of living organisms, their habitats and the interrelationships between organisms and their environment.⁴⁵ These authors stress that conservation is not just about individual plant and animal species, but also includes all aspects of biodiversity which form ecosystems. Conservation practices in recent years can best be identified by approaching biodiversity either from the ecosystem or from the genetic perspective. In nature conservation, interest is mainly focused on conservation at the habitat and ecosystem level, while for agricultural biodiversity, the main focus has been on conserving genetic diversity. Less progress has been made in the development of an overall system for genetic conservation that approaches biodiversity at the three levels, and also covers the human component in agrobiodiversity.

Conservation of crop genetic resources has been approached through two ultimately complementary strategies which approach biodiversity from the ecosystem and from the genetic level. The two strategies are differentiated according to where the conservation activity takes place. *Ex situ* conservation means the conservation of components of biological diversity outside their natural habitat, while *in situ* conservation means the conservation of ecosystems and natural habitats and the maintenance and recovery of viable populations of species in their natural surroundings and, in the case of domesticated and cultivated species, in the surroundings where they have developed their distinctive properties.⁴⁶

Ex situ conservation

Ex situ conservation of plant genetic resources is effectuated through genebanks, which store samples of seeds or other plant materials under controlled conditions of temperature and humidity, mostly in refrigerators and deep freezers for medium (4° C) to long term (-20° C) storage. The aim is to conserve as much as possible of the existing genetic diversity, ensuring its availability for future generations. Materials are collected through plant exploration and are briefly described (passport data) before being stored. The techniques for *ex situ* conservation are generally considered appropriate for the conservation of crops, crop relatives and wild species. The conservation of germplasm in field genebanks is another version of the *ex situ* strategy. It involves collecting of material from one location and transfer and planting of the material in a second site. It is usually the answer for the seeds of species such as rubber, coffee, banana, cassava, sweet potato and yam, which cannot be dried and frozen without loss of viability.

Over the past few decades, genebanks have proved vulnerable to several problems, including failing infrastructure (electricity cuts), under-funding and political instability. There are very sad stories of, for example, the genebank of the Rice

Research Station in Sierra Leone in West Africa, which was deliberately destroyed by bandits. In many genebanks the germination rate of accessions now falls well below the internationally agreed acceptable level of 85%. This is the case, for example, with the famous collection of the genebank of the Vavilov Institute in Saint Petersburg in Russia.

An important characteristic of genebanks is that they ‘freeze’ evolution or local crop development because genotypes are taken from their original environment and are no longer subject to the continuing adaptation to changing environment conditions and farmer selection. If properly stored, genebank accessions can be reproduced with little change after a long period of conservation. Yet, if the same population had been allowed to survive *in situ* or on the farm where it was collected, it might have undergone considerable evolution or crop development. *Ex situ* conservation also misses elements which may be essential for the future because the germplasm in farmers’ fields co-evolves with diseases and pests, changing farming systems and climatic conditions.⁴⁷

The information on accessions in genebanks is rather limited or inaccurate. The quality of the material stored is not only dependent on its viability but also on the availability of information on the material being stored. Passport data rarely include characteristics described by farmers or refer to the ecological conditions from which the material originates. Plant explorers often spend only a few minutes on each sample they collect. There is no time to chat with farmers and record their knowledge. The bond between the farmers or users’ knowledge and the biological material is thus broken.

Genebanks have also been criticized in the global debate on property rights in relation to genetic materials. For local communities, *ex situ* genetic resource collections are effectively extinct. Material kept in the genebank is made available to plant breeders and researchers, but not to the farmers and communities it came from.

Another issue related to property rights is the question of whose property the material is. According to the Convention on Biological Diversity,⁴⁶ national states have the sovereign rights over biological resources. This may be in direct conflict with the interests of local communities. They may choose to maintain their germplasm themselves or to give them to governmental genebanks under a black box agreement. In such an arrangement, the material is stored in the formal storage facility, while documentation remains with the owner, and material can only be taken out with their authorization. Such arrangements have developed to counterbalance the rise of intellectual property rights over genetic materials. It is alien to most open mechanisms of seed variety exchange in informal seed systems.

In situ conservation

In situ conservation as defined above aims at leaving species in their natural habitat, allowing adaptation and evolution to continue. This strategy has been adapted from those used in nature conservation. In the conservation of agricultural biodiversity, *in situ* conservation is specifically used to conserve semi-wild species or the wild relatives of crop species. In theory, it is particularly appropriate for habitats that are under

threat. These habitats can be natural, but may also have a clear human management component.

An example of such human involvement in *in situ* conservation is the conservation of grasslands or pastures. *In situ* conservation may imply that the grazing intensity of such pasture is managed in such a way that certain populations of wild species remain. Stopping grazing could cause other more competitive species to erode the target species. The GEF project on *in situ* conservation in Turkey aims to establish gene management zones or genetic reserves in areas that are rich in the targeted wild species related to the crops. This project works on the conservation of wild wheat species, for example, and its methods include controlled grazing, mowing or fire management to discourage perennial species, especially perennial grasses, from displacing the annual wild wheat relatives.⁴⁸ Another example of *in situ* conservation is the national coffee conservation programme of the Biodiversity Institute in Ethiopia. A special effort is being made to conserve the semi-cultivated coffee by small-scale farmers in areas, where forest coffee occurs spontaneously. This complements field collections now being maintained in a field genebank.⁴⁹

Conservation by farmers or farmer management

Another approach associated with *in situ* conservation entails the conservation of local varieties by farmers. In farmer management of genetic resources, the farming system or agro-ecosystem is considered the habitat where the genetic diversity originates from. People from conservation programmes tend only to consider such farming systems as important if the crop developed in that habitat (the centre of origin), as in the earlier mentioned definition of the Convention on Biological Diversity for *in situ* conservation. This approach was the subject of discussion in the 1990s, and has been recognized by the CBD and the FAO. It recognizes the role that farmers play in complementing *ex situ* conservation strategies. It is evident that maize has its origin in Mexico and Guatemala, but this does not mean that local diversity developed in the Horn of Africa or Brazil is irrelevant. This conservation strategy emphasizes the maintenance and continued use of this diversity. The same counts for example for bean and cassava diversity (both with an origin in South America) that is encountered in Africa: the conservation and use of this diversity by African farmers is valued and supported by this strategy.

Farmer management of genetic resources involves the maintenance of crop varieties or cropping systems by farmers within local agricultural systems. On many farms, especially in marginal production environments, local varieties or landraces are sown and harvested; each season the farmers keep some of the harvested seed for re-sowing. Thus the local variety is continuously grown in the specific production environment of the farmers. It is highly adapted to the local environment and is likely to contain locally adapted alleles. On-farm conservation has been a concept developed by conservationists rather than an objective of farmers. It is therefore important in this context that farmers become more active in the process of crop development. Hardon and De Boef⁵⁰ conceptualized local crop development as the complex of maintenance, utilization and improvement of crop genetic diversity by farmers; it is a continuous and dynamic process in which farmers manage crop diversity within

specific agro-ecological and socio-economic environments. Elements of local crop development are exchange of varieties, their maintenance and utilization, their enhancement and seed multiplication, processing and storage. It is built on farmers' knowledge and capacity to innovate with germplasm and seeds.

Conservation by farmers builds on the dynamics of local crop development, which anchor it in space and time. Different components of the seed system (e.g. seed source, seed flow, seed production, farmer selection, seed processing and storage) can (but do not necessarily) contribute to gene flow, migration, selection, mutation, and recombination. They constitute examples of adaptive processes that contribute to viable agricultural systems, and their contribution is highly context-dependent.¹⁴ We have to realize that farmers' management within the informal seed system changes continuously, like the biodiversity or the genetic diversity itself; this dynamic is the critical point within this 'conservation strategy'. Here lies the relevance of interventions in the name of conservation strategies to this book about farmers' dynamic use and conservation of local varieties. De Boef and Bishaw* clarify this linkage of the informal system to the formal system of conservation, plant breeding, multiplication, marketing and legislation. In one way or another, the formal system can contribute to the informal seed system through direct interaction. If an element of conservation and utilization of genetic diversity plays an important role in such interactions, it can contribute to the conservation or management by farmers of agrobiodiversity.

Linkages to contribute to farmers' use and conservation of agrobiodiversity

Improving the quality of seeds, supporting the diffusion of local varieties, and stimulating seed exchange: all such activities contribute to the informal system, and may play an important role in farmers' conservation of agrobiodiversity. It should however be realized that these activities may also lead to variety displacement or genetic erosion, which is inherent to the dynamic nature of the informal seed system. It is important to realize that they may all contribute to the strategy referred to as conservation by farmers, as long as utilization of genetic diversity by farmers is kept in focus. In this way, participatory plant breeding and supporting informal seed supply activities may be far more effective contributions than anything conservationists can do alone.

These contributions to conservation by farmers can take place in different ways. Their activities can be primarily to monitor the changes to genetic diversity in the informal system, but can also include direct interventions or collaborative actions. In pursuing the conservation and continued use of agrobiodiversity or local genetic diversity, the following options for linking the formal to the informal system and vice versa can be considered:

- Restoring and reintroducing local varieties to rural communities, aiming to increase access of farmers to both their indigenous and exotic germplasm. The

* Walter de Boef and Zewdie Bishaw elaborate the system perspective on formal and informal seed supply in Section 1.3.

Ethiopian Biodiversity Conservation Institute is involved in such activities, restoring indigenous germplasm to the original communities.*

- Supporting and strengthening existing local seedbanks or those farmers or communities that have a traditional role in maintaining a higher degree of diversity in their community^{†‡}.
- Participatory varietal selection: this is another example of a conservation action with a strong association with variety improvement. In participatory varietal selection, the question emerges of who controls the enhancement: the conservationists or farmers? And with what goals? Crop improvement, continued adaptation or conservation? If the local seed system is taken as a basis, the farmer should be a crucial and decision-making player in this activity.[§]
- Addressing the shortage of information from farmers on their germplasm management, in documentation and information systems of genebanks. Documentation of indigenous knowledge, for example in community biodiversity registers, requires special attention as it will enhance the quality of the collections. Few methods are available for data collection, processing and management for indigenous knowledge about agrobiodiversity. This issue broadens the field of agrobiodiversity management across the boundaries of the biological sciences into the social sciences.

Geneticists and conservationists have an important role in monitoring the dynamics of local management of agrobiodiversity and assessing the impact of interventions by the formal seed system on the informal one. As farmers may adopt other varieties, stimulated by market forces or government policies, or as diseases may wipe out certain landraces, immediate interventions to collect genetic materials may prove necessary. This specific monitoring role is not unlike that of conservation biologists working on the *in situ* conservation of wild habitats. Where conservation biologists monitor ecological processes, the focus in management on-farm is the agro-ecological processes of local crop development.

Enhanced linkages between the formal and informal seed system can contribute considerably to the conservation and utilization of biodiversity in agriculture at the farm level. The current book takes the informal seed system as the starting point for the development of interventions to enhance the availability of and access to seed of

* Girma Balcha and Tesema Tanto describe the efforts of the IBC to support informal seed supply through re-introduction in Section 3.4; Johannes Engels, Severin Polreich and Ehsan Dulloo further elaborate on the effectiveness on community genebanks and seedbanks in contributing to the conservation of genetic resources in Section 3.5.

† Fetien Abay and Trygve Berg describe the efforts to support community seedbanks in Tigray in Section 2.3.

‡ Pitambar Shresta and colleagues describe a project supporting the establishment of community seedbanks contributing to community biodiversity management in Nepal in Section 2.4.

§ Various sections in Chapter 4 address the linkage between participatory plant breeding and varietal selection, and supporting informal seed supply and community management of local varieties.

both improved and local varieties. This position is a starting point for the implementation of the conservation strategy known as farmer management or community management of agrobiodiversity, and referred to by conservationists as *in situ* conservation on-farm. With the current focus on seed systems and participatory approaches, farmer or community management are the preferred terms, as they indicate that we are not only dealing with a single conservation action like putting seeds in a freezer, but that we need to address issues of agrobiodiversity at agro-ecosystem or landscape, species, genetic and human levels – all at the same time. This approach emphasizes, firstly, working closely together with farmers and communities, and, secondly, taking a diversity oriented approach including other crop development activities such as supporting farmer seed management. The approach incorporates conservation or diversity goals into all interactions between the formal and informal system, thereby integrating a diversity orientation into crop development and seed sector development.²⁹ Not only does the approach contribute to agrobiodiversity conservation, it also takes away a root of the problem in stimulating agrobiodiversity use as a way to create a more sustainable agriculture. The efforts reported in this book, which places informal seed supply within the wider perspective of crop development, merge conservation-oriented and seed sector development-oriented approaches to form a diversity-oriented approach to agricultural, rural and regional development.

3.2 Informal seed systems and on-farm conservation of local varieties

Bhuwon Sthapit, Ram Rana, Pashupati Chaudhary, Bimal Baniya and Pratap Shrestha

The immense genetic diversity of traditional farming systems is the product of human innovation and experimentation. Farmers throughout the world continue to maintain and manage substantial diversity in agricultural production systems. Traditional crop varieties are an important element of this diversity and constitute a key resource maintained and used by poor farmers in difficult production environments. Most rural farming communities in developing countries continue to use informal sources of seed and vegetative planting material. Either they save their own seed or they obtain seed from relatives, neighbours and local markets that are independent of the formal certified seed sector. This informal system of seed supply is an integral and traditional part of social customs and practices. Because of this social foundation, it is important to the conservation of crop genetic diversity on-farm. In this section, we discuss various components of the seed system, such as seed source, seed flow, seed production, farmer seed selection and storage. Secondly, we relate these components to the way farmer seed management shapes the genetic structure of crop variety populations in farmers' fields. We identify a range of stress factors that influence the

informal seed systems, and explore how these factors affect them as systems for maintaining and using crop genetic diversity.

The conceptual framework of seed systems

Seed systems are defined as the ways in which farmers produce, select, save and acquire seeds. In line with this, Conny Almekinders, Walter de Boef and colleagues^{51,*} discuss seed systems in terms of the seed flows through production systems and the roles of both formal and informal sector institutions and farmers in these flows. Shawn McGuire⁵² studied a seed system that constitutes the various processes involved in seed provision, selection and seed storage. Weltzien and Vom Brocke⁵³ use a more farmer-oriented framework for understanding the function of a seed system; they suggested that seed systems have to fulfil a series of functions so that healthy viable seed of the preferred variety is available to farmers at the right time, under reasonable conditions and in ways that ensure choice of seed that land and labour resources can use optimally. A healthy seed system includes four important components: (i) it maintains a germplasm base that provides diversity, flexibility and a base for selection; (ii) it produces quality seed for production (free of seed-borne disease; high germination and vigour), (iii) it ensures seed availability and distribution (seed sources, social networks, markets), and (iv) it involves sharing of knowledge and information about seed (growing methods, utilization, knowledge of new materials). Toby Hodgkin and Devra Jarvis¹⁴ take a holistic view of a healthy seed system: it should have properties of stability, resilience, diversity, efficiency and equity. Following the model described in Section 3.1, both the formal and informal seed systems are recognized. In many countries in the world, the formal seed sector plays an important role in seed provision of improved varieties, whereas traditional varieties are generally distributed through informal systems. Even seeds of varieties developed by the formal sector are often maintained and distributed in the informal system. The informal seed system plays a central role in the provision of planting materials in developing countries; in Nepal more than 97% of the seed of the main staple, rice, was purchased from the informal sector in 1999-2000.⁵⁴

Farmer seed system and on-farm conservation

In the case of Nepal, large numbers of farmers practise a traditional form of seed management. Farmers use a wide range of criteria and practices in seed selection and management, which affects the local level of crop genetic diversity. One important example of how the seed flow affects varietal diversity is the farmers' decision on whether to save seed from their own harvest or to obtain it from other sources. In the municipality of Kachorwa in Nepal, 32% farmers save their own seed and 68% farmers use outside sources. In another municipality, Begnas, 44% farmers save their own seed, 54% depend upon relatives and neighbours and 2% farmers use other outside sources. In the municipality of Talium, 79% farmers depend on their own saved seed, 19% on seed from relatives and neighbours and 2% of farmers use outside

* Walter de Boef and Zewdie Bishaw elaborate the system perspective on formal and informal seed supply in Section 1.3.

sources (Table 3.1). The dissimilar situation in the three municipalities can be explained by the difference in farmers' access to information and technologies, which is greater in Kachorwa than in the other two municipalities.

Table 3.1 Seed source of rice seeds in the three communities with different ecosystems of Nepal⁵⁴

<i>Seed source</i>	<i>Seed sources (%)</i>		
	<i>Kachorwa † (Low land)</i>	<i>Begnas †† (Middle hill)</i>	<i>Talium ††† (High mountain)</i>
Own retention (self saved)	32	44	79
Neighbours	40	46	11
Relatives	8	8	8
Other sources	20	2	2

Notes: † = Plain area of lowland belt of Nepal bordering India with easy access to information and commercial seeds and inputs; 50-150 m asl; †† = Middle hill with alluvial flat lake valleys of Nepal with intermediate access to information and genetic resources; 600-1400 m asl; ††† = High altitude remote site with very poor access to information and technologies and inputs; 2200-3000 m asl.

However, observations to date suggest that this process may change over time. If seed availability is a problem, farmers' willingness to replace poor quality seeds and interest in testing new varieties is increased. Farmers' decisions results in replacing old seeds with new ones. The majority of farmers prefer not to replace all their seeds with seeds from outside sources within one year, but the practice may differ across regions and among crops. This process is always dynamic and is an important farmer practice when approaching the informal seed system with a focus on the maintenance of local diversity through migration and re-distribution of the landrace populations.⁵⁵ Seed selection, handling, processing and storage techniques, and exchange practices vary among communities and among crops, because of dissimilar reproductive biology. Farmers' seed selection practices do not differ between local and modern varieties; what actually matters is whether local and modern varieties are grown in small or large areas, the extent to which they are mixed, and cultural and religious use values they possess. All the aforementioned practices can have dramatic effects on the diversity of crop varieties and their yield potential.

Seed flows through farmers' seed networks employ a diversity of means. Farmers mainly rely on informal networks for seeds, although they also access seed from formal sources and markets. In informal seed networks, resource-endowed households serve as 'resource pools' on which resource-poor farmers depend for varietal diversity. Women play significant roles in seed selection and exchange of genetic materials. In Nepal, seed exchange plays a predominant role in rice seed flow, followed by gift and purchase. Exchange takes place among farmers, who exchange seeds of dissimilar varieties or barter seeds with edible grains. Seeds are purchased from other farmers or at markets. In Kachorwa, people also borrow seeds from their neighbours and relatives; this practice does not exist in Begnas (Table 3.2). Borrowed

seed is often returned by offering twice the amount borrowed after the crop harvest. Seed flow differs between local and modern varieties. Practices change with interventions such as the introduction of new practices and approaches by the change agents. Hence it is essential to monitor the impacts of such interventions on local practices that are friendly to the evolutionary process embedded in farmer or community biodiversity management.

Table 3.2 Characterization of rice seed flows in Kachorwa and Begnas, Nepal

<i>Type of seed flow</i>	<i>% flow of genetic materials</i>	
	<i>Kachorwa</i>	<i>Begnas</i>
Exchange	64	53
Gift	17	31
Purchase	9	16
Borrowing	10	-

Stresses in farmer seed systems and their implications for on-farm management

A series of indicators of stresses have been identified by Louise Sperling.⁵⁶ These indicators are useful in addressing seeds systems in the context of on-farm conservation of local crop diversity: (i) changes in access patterns (access); (ii) changes in the variety and the quality of seed (flexibility); (iii) use of sub-optimal varieties (quality); (iv) lack of stored seed (availability); and (v) increase in seed price (access). It is essential that farmers and communities are empowered to analyse this kind of information and develop community-based practices to mitigate these stresses. This can be done using social seed network and seed flow analysis, a tool that assists in analysing farmer seed flows, highlighting the diversity between and within varieties that are considered meta-populations in ecological niches. Farmer populations of a local variety represent subpopulations, seed flows represent migration, and rates of seed exchange determine extinction and colonization. Seed exchange practices resemble source and sink dynamics of the meta-population theory.⁵⁵ Monitoring of informal seed systems over the years reveals that they are not only changing but are also showing symptoms of stress. The changes take place rapidly because the number of stakeholders involved in informal seed systems has increased.⁵⁷ In many developing countries, formal breeding and extension policies tend to discourage informal ways of developing, maintaining and sharing varieties. As a result, a large number of valuable traditional local varieties have become vulnerable to extinction. Therefore, it is essential to implement interventions that support community management of farmers' varieties and mitigate stress in the informal seed system. Efforts to strengthen informal seed networks would require policy changes in the government's frameworks for research and extension, and seed regulation.

3.3 Genetic diversity and informal seed systems in Ethiopia

Girma Balcha and Tesema Tanto

Ethiopia is one of the most diverse regions in the world, with a great topographical variation ranging from 100 meters below sea level in the Danakil depression to 4620 meters above sea level at Mount Ras Dashen. Within this range, the country has rugged mountains, flat topped plateaux, deep gorges, incised river valleys and rolling plains. Together with its proximity to the Middle East and the Gulf this topographic variation has made the country one of the world's richest regions in terms of plant origin and diversity. The size of the Ethiopian flora is estimated to be about 7,000 species of vascular plants, 12% of which are considered endemic to Ethiopia.⁵⁸ Furthermore, crops that were originally domesticated elsewhere exhibit extreme secondary diversification in Ethiopia, and there has been continued interaction between cultivated crop plants and their wild relatives under diverse ecological, social, and economic conditions. This interaction, coupled with farmers' selection and maintenance of crop plants, constitutes the informal seed system in Ethiopia.

The functioning of the informal seed system has been studied in several parts of the world.¹⁴ A fundamental feature of the informal seed system is its interrelationship with food security and with diversity – with understanding diversity at the ecological level, sustaining diversity at the farm level and using diversity at the genetic level. In the management of their varieties, small farmers balance factors of increasing genetic diversity (mutation, migration and hybridization), with factors of decreasing genetic diversity (selection and genetic drift). Ethiopian farmers developed diversity by traditional methods of maintaining different crops and their varieties through saving sufficient amounts of representative seed samples for the next planting season, buying local seed from the village markets, and making use of farmer-to-farmer seed exchange networks. For much of agricultural history, crop improvement and seed supply have remained farmer-based activities. The objective of this section is to demonstrate the importance of the genetic diversity maintained in the informal seed systems in Ethiopia for sustaining food security and improving the livelihoods of small holder farmers.

Local varieties and agricultural inputs

The informal seed system supports sustainable production in marginal agricultural production systems. This is due to the broader genetic basis of the informal system: farmers have maintained the diversity of their crops over time because of specific adaptations to local agro-ecosystems. Farmers cultivate crop populations in environments that are heterogeneous in space and often unpredictable in time, and local varieties often differ in their response to such environmental variations. Genetically diverse populations are less susceptible to high levels of attack by pathogens and herbivores. Thus, in systems where farmers have limited capacity to control spatial and temporal environmental variability with material inputs, planting a diverse assemblage of genotypes can lower the risk of failure and increase food security. Specific cropping system practices support the maintenance of soil fertility,

e.g. the use of limited plots of land in rotation between cereals and pulses and oil crops.

Food security and cultural values

In Ethiopia, farmers continue to produce local varieties of crops because of their contribution to food security and their use for multiple food purposes. In the marginal environments of Ethiopia, local varieties are closely associated with the livelihoods of the farmers. For example, local varieties of barley in the highlands of Ethiopia account for over 60% of the food of the local population. They are used in many traditional foods (soup thickeners, stews and dressings) and local beverages.

Certain crop species and wild species are especially maintained in specific communities for cultural reasons, and are used for social gatherings, cultural ties and religious events. For example, barley is said to be one of the first cultivated plants among the Oromos in Ethiopia and is grown by many Oromo communities, who prepare a local beverage out of the first barley harvest each year for thanks-giving to God. This ceremony takes place early in November.

Traditional recipes prepared from barley local varieties include: *Besso* and *Chuko* (both made with a fine flour of well-roasted barley grain), *Kollo* (cleaned and roasted whole grain), *Kinche* (prepared from coarse flour boiled in water), *Tresbo/Kitta* (sieved flour kneaded into dough with water and flattened thinly on a hot circular iron or clay plate), *Atmit* (the dehulled grain roasted lightly, and the milled and sieved flour mixed with water, and cooked), and *Injera* (leavened, thin, flat spongy pancake-like local bread served with a sauce (*Wot*) that might be prepared either from pulses, vegetables, or meat and usually served as the principal food at lunch and/or dinner). *Injera* is a staple food in many parts of the country. *Injera* made from barley is next in preference to *Injera* made from teff. *Injera* can also be prepared from barley blended with other cereals such as teff, wheat, maize, and sorghum. Often, *Injera* is prepared using local varieties with characteristics like high flour yield, high water absorption capacity, white seed colour and big seeded grains.

Tella is a traditional fermented local beverage, which is indispensable at festivals in most parts of the country, and at social labour-pooling gatherings in some areas.⁵⁹ The preparation procedure for *Tella* differs from place to place, but in general the main ingredients are locally made malt from barley *Abshillo/Kitta* (a pancake-like substance prepared from a 4 to 15-day-old dough of barley flour), *Asbaro* (roasted seed from barley grain), and dried and pounded hop leaves. For *Tella* preparation, local barley varieties with black seed colour are generally preferred. Similarly, these black-seeded local varieties like *Anbediat*, *Demiye*, *Tikurgebs*, and *Tikurmanjje*, are commonly preferred to make a local spirit called *Areke*. These black-seeded local varieties also have medicinal values for both humans and animals; they are used for humans, for example, to heal broken bones, and for strengthening women during the first two to three days after delivery.

Local seed storage practices

Farmers in Ethiopia traditionally smoke the seeds for the next seasons' planting, e.g. maize and sorghum or vegetables seeds, on the ceiling of their houses. This has two

purposes: (i) fumigation of seeds against insect pests, and (ii) sufficient drying to maintain seed viability for a long time. Another common practice among many communities is ground storage under anaerobic conditions. This practice is commonly used for the storage of sorghum seed in the rift valley areas. Semi-sedentary farmers used to store sorghum and other seeds in a specially made pit in the ground to conserve seeds in dry years before leaving the place in search of water and grasses; they used to come back later and grow their seeds when rain came. These examples show that farmers have generations of experience in securing their seeds for their livelihood; at the same time they maintain genetic resources for the current generation.

Local varieties and animal production

Traditionally, farmers have fed their cattle, sheep, goats and other animals with the straw and chaff of local varieties. The major crops used for feed are: maize and sorghum stalk and leaves, barley and wheat straw and chaff, and cucumber leaves. As an example, for fattening animals for sale or enabling recovery from sickness, malt of farmer varieties of barley is crucial. Race horses are fed with local barley varieties. Horses fed with local barley are selected for the bride and bride groom during a wedding. When people began to cultivate improved varieties, with their characteristic dwarf stalks, the production of grain increased, but the production of animal feed decreased. Because of this, women were forced to search in the forest for animal feed and started trimming live branches and leaves for their animals as supplementary feed. This accelerated the deforestation problem.

Market value of local varieties

A farmer who is able and willing to produce a local variety for sale in the market (local or elsewhere) has to base his production decision on his knowledge of consumers' or intermediaries' demands, and their willingness and ability to buy the variety. A market study identifies and characterizes the commodity to be marketed, as well as analysing the marketing channel, i.e. the marketing costs and margins, based on a systematic knowledge of the flow of the commodity from the producer to the consumer.⁶⁰

In general, a landrace or local variety is not a marketable commodity that can be traced as described for market channels, with an analysis of market shares and margins for market participants. The market for specific local varieties and even for local varieties in general, is generally restricted to the village level, and mostly to the level of farmer-to-farmer exchange. Specific local varieties as such usually exist only at the farm gate. Beyond that, even at the rural assemblers' level, local varieties and improved varieties, and different types of the same crop varieties are found mixed and undifferentiated for further market channel analysis. This is happening despite the fact that in Ethiopia over 90% of the food crops grown and sold are local varieties/farmer varieties by type; however, they are not classed as a commodity or a group of commodities.⁶¹

Nowadays, the market demand for organic agricultural products is increasing. Since most smallholders growing local varieties do not use fertilizers and other inorganic inputs in the production of their annual crops such as sorghum or durum wheat, the transition to organic production is said to be relatively easy. Durum wheat

and malt barley varieties presently grown as local varieties (traditionally used for Ethiopian bread or *Tella*) are products that could capture established pasta and beer making markets, both national and international. These are markets that require large-scale and reliable supplies of consistent and uniform quality. It may prove difficult to organizing smallholders to produce uniform products to go through the strict organic product certification system dominated by Western countries. What may be more feasible is smallholder organic coffee production, with small-scale farmers organized into cooperatives. The Oromia and Sidama Organic Coffee Growers Cooperative Unions have made headway in this regard. Commercial farms could provide a nucleus for smallholders, included as outgrowers, technically supported by such farms and jointly marketing their products. A commercial organic sesame farm has started production with such an out-growers scheme in the north-western parts of Ethiopia.

Local varieties and improved varieties are not distinguished by price in the district, regional and national markets. This shows that price is not a discouraging factor for their production. Farmers who promote local varieties and organic agriculture deserve incentives until they grow to the level of getting a sustainable market. There is a need for a certification process for the informal seed system.

Threats to genetic diversity and the informal seed system

The threat of genetic erosion is evidenced by the fact that agricultural development in developed and developing countries alike has been accompanied by the replacement of local populations of crops with a handful of modern varieties. The biggest danger associated with genetic uniformity has been the vulnerability of the varieties to new pathogens, pests and environmental stresses and hazards, which can potentially result in economic losses worth millions of dollars. Because of the traditional nature of agriculture in Ethiopia, which is characterized by small-scale farms and a rich species diversity, the devastating consequences of varietal genetic uniformity have not been realized. However, Ethiopia is no exception to the progressive occurrence of genetic erosion.

Severe and recurrent drought conditions that led to starvation caused genetic erosion by forcing poor farmers to abandon farming and migrate to other areas. In the past, this often resulted in massive displacement of native varieties by exotic varieties provided by relief agencies in the form of food grains. This has been the case in the regions of Wello, Tigray and Northern Shoa.⁴⁹ When rainfall patterns change, it may be difficult to grow local varieties that were once suitable to that locality. The destruction of forests and bush lands to clear land for agricultural crops or pasture land often causes genetic erosion for crops with products that are collected from the wild, and wild relatives of crops. Forest coffee and many other spice crops are seriously threatened by this process.⁶² The shift towards the use of improved varieties instead of farmers varieties is driven by two factors: (i) government policy and legislation in support of improved varieties 'to boost agricultural production', and (ii) inadequate direct financial incentives for the individual farmer to continue growing local varieties.

The occurrence of genetic erosion in farmer varieties, however, should be looked into cautiously since the extent may vary depending on the region, the nature

and the evolutionary history of the crop, the breeding strategies used by crop improvement programs, and the successes of these programs. Exotic varieties do not pose any immediate threat where most of the germplasm materials used in breeding programs represent the indigenous landrace population. Teff, sorghum, various pulses, oil crops and coffee, amongst others, can be included in this group. Genetic erosion still progresses, however modestly, on account of extensive selection and expansion of homozygous pure lines. On the other hand, indigenous local varieties of barley and durum wheat are the most threatened,⁴⁹ not by their exotic counterparts (despite the wide use of germplasm from abroad in the breeding programmes), but rather by their replacement either by the indigenous crop, teff, or by exotic varieties of bread wheat. The reasons lie in the greater market demands, the associated premium price, and the economic lead that these crops have.

The need to support and recognize the informal seed system

The informal seed system plays a crucial role in providing seed to resource poor farmers in rural communities. It enables the farmers to continue to develop and maintain biodiversity and associated traditional knowledge, and transfer practices from generation to generation. There is a need to support community seed networks through which farmers would be able to get the desired local varieties, but also have access to high yielding improved varieties adapted to their local growing conditions. The system needs to have linkages with appropriate market chains through designed extension support in which the private sector, including farmers, play a role. The private sector would benefit from using farmers' varieties in variety improvement programmes. Farmers need locally adapted improved varieties as well. In this way, both the private and the informal seed system would strike a balance between local and improved varieties.

3.4 Conservation of genetic diversity and supporting informal seed supply in Ethiopia

Girma Balcha and Tesema Tanto

Local varieties' adaptation to marginal agricultural ecosystems

Local varieties are genetically diverse and well adapted to local agro-ecosystems. Local varieties have important qualities such as pest resistance, frost tolerance, and post harvest storage properties consistent with traditional technologies, which further increase their overall productivity. Farm-based enhancement of local varieties leads to improved and more reliable yields. Many poor farmers throughout Ethiopia, and particularly those in marginal environments, have to produce crops in conditions of unpredictable but recurring drought, low soil fertility systems, and without inorganic fertilizer and agro-chemical inputs.

Although modern improved varieties may produce good yields under near optimal farming conditions of rainfall and a complete input package, they frequently

under-perform in adverse conditions. In contrast, traditional landraces or local varieties can perform more reliably under poor conditions, and incur few of the additional input costs, such as inorganic fertilizers, required by many improved modern varieties.

In general, plant breeders have found it difficult to develop viable improved modern varieties for marginal environments, in part because of an incomplete understanding of why farmers choose to produce their traditional landrace varieties. One of the common assumptions by breeders is that improved varieties selected in more optimal environments will also out-yield landrace populations in marginal environments, so that marginal environments are not specifically targeted in breeding programmes.⁶³ As a result, many farmers do not have a real choice between improved modern and local varieties, because none of the improved varieties are appropriate for their marginal environments, or fulfil their diverse needs.

Maintaining local varieties as a key feature of small-scale farming systems enables local farmers to retain shared ownership and control over the genetic base of their crops, breeding and adapting their local varieties to suit field conditions in highly variable agro-ecosystems. Farmers can therefore choose to rely less on improved varieties, over which they may have little or no genetic control. The conservation and sustainable use of crop diversity for sustainable livelihoods and poverty alleviation has been internationally recognized in several landmark agreements including the Convention on Biological Diversity (CBD).

Local varieties in the course of selection, recombination, and mutation have developed their distinctive traits to adapt to marginal production environments. For example, crops like sorghum are adaptive to drought. Farmers sow sorghum seed even under low moisture conditions before the onset of the rain, which is called 'dry planting'. The seed germinates and shows slow growth in the early developmental stage, however during subsequent rains, it develops well to reach the reproductive stage. With land degradation, soils have become acidic in many places, and soil fertility is also deteriorating. Local varieties which have adapted to these conditions show stable yields. Certain traditional varieties of barley have developed characteristics that enable them to withstand frost hazards. Depending on the type of changes in the environment, crop species can develop the resilience to adapt to various changes in climate.

One has to question why local varieties have not been given due attention, although they are available in huge diversity in Ethiopia, especially for crops where Ethiopia is a centre of origin, like sorghum and teff, and for crops where Ethiopia is a secondary centre of diversity, like barley and durum wheat. On the other hand, a large number of crops like coffee can be enhanced using the existing gene pool for specific quality traits like low caffeine content from the wild coffee. The stable production of farmers' varieties and the increased grain yields of certain crops in marginal lands have not been fully incorporated into modern varieties; nor has their use in the agricultural extension system been supported. The importance of farmers' varieties for food security needs to be recognized, and international marketing opportunities need to be further explored.

Ex situ conservation of local varieties

It is generally accepted that genetic diversity in crops is not evenly distributed across the world. Ethiopia has been recognized as among the few genetically rich areas of the world in terms of crop diversity ever since the expedition by a Russian plant collector, N.I. Vavilov, in 1927. Under Ethiopian conditions, crops such as teff, (*Eragrostis Tef*), sorghum (*Sorghum bicolor*), Niger seed/noog (*Guizotia abyssinica*), gomenzer (*Brassica carinata*), and others have been domesticated and have developed a wide range of adapted landraces or local varieties. Although crops like finger millet (*Eleusine caracana*), cowpea (*Vigna unguiculata*), sesame (*Sesamum indicum*), barley (*Hordeum vulgare*), durum wheat (*Triticum durum*), faba bean (*Vicia faba*), lentil (*Lens culinaris*), field pea (*Pisum sativum*), grass pea (*Lathyrus sativus*), chick pea (*Cicer arietinum*), safflower (*Carthamus tinctorius*), and others were domesticated elsewhere, an immense variation in agronomic and economic traits is encountered in Ethiopia. In the early 1970s, the Consultative Group on International Agricultural Research (CGIAR) strongly recommended the formation of a network of plant genetic resources centres (or genebanks as they are commonly called) around the world. Ethiopia was given highest priority because of its tremendous wealth of genetic diversity.

Table 3.3 Number of germplasm accessions collected, conserved *ex situ*, and characterized at the IBC until 2007, with the regional distribution of local varieties

<i>Crop category</i>	<i>No of species</i>	<i>Total no of accessions</i>	<i>% accessions</i>	<i>% Characterized</i>	<i>Tigray</i>	<i>Afar</i>	<i>Ambara</i>	<i>Oromia</i>
Cereals	9	40025	69	42	3260	44	9464	10960
Pulses	10	7333	13	6	388	-	2955	2064
Oil crops	8	7290	13	6	267	-	1757	1504
Industrial crops	4	120	0.2		-	-	50	22
Others	94	3561	6		20	-	580	991
Total	125	58329		54	3936	44	14809	15541

<i>Crop category</i>	<i>Somalia</i>	<i>Benshangul gumuz</i>	<i>SNPPR</i>	<i>Gambella</i>	<i>Harari</i>	<i>Addis Ababa</i>	<i>Diredawa</i>	<i>Donation/ unspecified</i>
Cereals	152	104	2055	353	25	38	96	13474
Pulses	21	79	576	18	-	4	1	1227
Oil crops	14	47	306	14	1	4	1	3375
Industrial crops	-	7	19	2	-	-	-	20
Others	10	110	820	68	2	12	4	944
Total	197	347	3776	455	28	58	102	19040

In recognition of the importance of conserving plant genetic resources, and in order to avert the danger of genetic erosion, the former Plant Genetic Resources Centre/Ethiopia (PGRC/E) – now the Institute of Biodiversity Conservation (IBC) – was established in 1976. So far about 58,000 accessions are conserved *ex situ* for field crops, of which 69% are cereals. For more details of the collection, including the regional distribution of the collected germplasm material, see Table 3.3.

The Institute of Biodiversity Conservation not only collects and characterizes these landraces, but also supplies seeds to national and international research centres upon request and after reaching agreements. From these materials, a number of promising improved varieties were developed through national research. Overall some 103 improved released varieties from the total of 146 released varieties developed have their basis in local varieties (Table 3.4).

Table 3.4 Crops collected by IBC and used to develop improved varieties in Ethiopia

<i>Crop type</i>	<i>Total no of released varieties</i>	<i>Released varieties from local varieties</i>	<i>% Local varieties from total release</i>
Teff	16	16	100
Durum wheat	13	13	100
Emmer wheat	1	1	100
Sorghum	18	14	78
Finger millet	3	2	67
Faba bean	14	10	71
Field pea	18	12	67
Chick pea	7	1	14
Haricot bean	18	5	28
Niger seed/Noug	4	4	100
Rape seed	4	3	75
Sesame	10	5	50
Coffee	20	17	85
Total	146	103	71

Source: National Agricultural Input Authority, Crop Variety Register Issue Numbers 3-6.

On farm conservation and the sustainable use of local varieties

Landraces are genetically diverse populations that form a bridge between wild and modern cultivated varieties. Through human selection, adaptation and exchange of genes with wild species, they form an important genetic diversity that has evolved in local environments over long periods of time. Local varieties form an indispensable source of genetic material for plant breeding and much of the world's food supply depends upon the development of new crop varieties. Indigenous landraces are of tremendous value as sources of genes for providing resistance to diseases, pests, drought and other stress conditions. For example, a gene from an Ethiopian barley landrace protects California barley from viruses, and saves some US\$ 160 million dollars per year.

Many small-scale farmers in Ethiopia and elsewhere in developing countries have often traditionally retained a diverse informal seed stock. The seed stock includes a range of varieties for several crops. This enables them to choose the variety that best suits the highly variable agro-ecological conditions, changing from year to year and even from field to field. By continually generating and maintaining a diverse seed stock, farmers are able to retain closer control over desirable crop traits.

Initial conservation efforts by the international scientific community focused on collecting and maintaining germplasm *ex situ* in genebanks. However, it has become increasingly evident that *ex situ* conservation of local varieties must be complemented by on-farm or *in situ* conservation under local farming conditions if the evolutionary interaction between crop varieties and their wild relatives, crucial for generating potential genes, is to be maintained.

A Dynamic Farmer-Based Approach to the Conservation of Ethiopian Plant Genetic Resources Project was undertaken from 1995 to 2002, supported by GEF and UNDP and based at the Institute of Biodiversity Conservation. A key element of that project was to work with local farmers in their farming systems, enhancing popular local varieties and conservation, particularly through farm-based participatory plant breeding using crop conservation associations and community seedbanks. This practice has linked *ex situ* conservation with *in situ* or on-farm conservation in different agro-ecological farming systems. An example of synergy that has emerged from this project is an innovative contribution to addressing the pressing food security and sustainable livelihood challenges faced by many poor farmers in Ethiopia. The project has demonstrated that farm-based landrace conservation can yield real food security and sustainable livelihood benefits, particularly for poor food-insecure farmers in marginal agricultural areas, while conserving biodiversity.

Twelve community genebanks or seedbanks were established in four regions of the country, namely Tigray, Amhara, Oromia and Southern Nation Nationalities and Peoples Regions (SNNPR). From 1997 to 1999, in these four regions two districts (*woredas*) each were selected based on variation in agro-ecosystems, landrace crops, extent of genetic erosion, etc., making the total number of districts 12. To ensure the seed supply in each district and to strengthen the efforts of conservator farmers, some 137 tons of 64 farmer varieties were purchased from nearby communities and stored in community genebanks, which stored seeds of two to eleven crop species. Johannes Engels and colleagues give more details on the community gene/seedbanks in Section 3.5 of this book.

The community gene/seedbanks were constructed with the objectives of safe seed storage, seed supply, seed processing, farmers training and the creation of office space for the curators. Farmers also view community gene/seedbanks as helping to lower the risk of inter-seasonal seed storage, as they return the seed loaned to them at the beginning of the previous season at a low interest rate (10-15%) and then re-borrow new seed at the start of the next planting season. Community gene/seedbanks have now become very popular among conservator farmers. For example, project reviews towards the end of the project revealed that between 85 and 90% of the conservator farmers were obtaining their planting seed from the community gene/seedbanks, augmented by their own conserved seed.

Based on the rules and regulations of the country related to the establishment of associations, i.e. Proclamation No. 147/91, the Ministry of Agriculture and Rural Development (MoARD) and respective cooperative offices of the regions organized 12 crop conservation associations with a total membership of 3359 farmers, of whom 16% are female farmers. These associations have the objectives of: (i) conservation of landrace crops with the associated traditional knowledge; (ii) common use of the

community gene/seedbanks for seed storage; (iii) provision of seed loans at comparably low interest rates; (iv) replacement of already lost landrace crops through reintroduction from the national genebank and restoration in their respective agro-ecosystems; and (v) purchase of the required local landrace seed and enhancement for further use.

Participatory genetic enhancement of local varieties

The IBC practiced landrace enhancement with the objectives of: maintaining diversity, keeping the integrity of the landrace population, and using low inputs while identifying the characteristics needed to upgrade the overall performance of the landrace populations, including market value. Farmers participated in the landrace enhancement practice; they chose the desired traits for their local environment, including characteristics related to social, gastronomic, economic and cultural values. In this way, with the participation of farmers, local varieties were evaluated and compared with improved modern varieties. For example, Table 3.5 shows the preference criteria formulated by farmers in Lume and Chefedonssa districts for the selection of durum wheat landrace populations.

Table 3.5 Farmers' and researchers' comparative evaluation of durum wheat local varieties, with improved durum wheat varieties at the IBC in situ sites

<i>Factors considered</i>	<i>Local varieties</i>	<i>Improved varieties</i>
• Adaptation	Adapt well to low moisture and planted in August	Long maturing and planted in June
• Need for inorganic fertilizer	Require small amount	Fertilizer compulsory
• Seed requirement	Less seed per unit of land 76% less than the requirement of improved seed	Recommended rate is compulsory
• Tillering	High tillering capacity, 30-50% more than improved varieties	Few tillers, often less than 10
• Shattering	Non shattering, would last long before harvest	Shatters if not harvested immediately after maturity
• Grain weight per unit volume	Heavier, a sack of 100 kgs weighs up to 30 kg more	A full sack of 100 kg weighs the same
• Disease, pest, weed and frost resistance/tolerance	More tolerant	Often unpredictable
• Yield stability	Fairly stable or within predictable range	Unpredictable, highly variable
• Utility	Multiple food use	Limited choice
• Baking or dough quality	Good water holding capacity	Poor water holding capacity
• Storage quality of grain	Stay for more than six months	Attacked by weevil shortly after storage
• Use of straw	High feed value	Feed value is inferior
• Nutritional value	High filling ability	Poor filling ability

Both men and women were involved in the evaluation. The selected genotypes were multiplied and evaluated for yield potential and other attributes in the context of

farmers' production practices in various fields. Interestingly, most local varieties performed better than improved varieties under marginal production conditions in medium and poor production seasons. However, under optimum production conditions, improved varieties were superior. This shows that improved varieties are the best yielders only in optimum production conditions for their complete production packages.

Our studies have demonstrated that, despite their high yield potential, improved varieties failed due to adverse soil conditions and frequent drought under both bad and medium production conditions. On the other hand, local varieties did relatively well, without the application of inorganic fertilizers and other agrochemicals. A further significant finding was that successive generations of landrace varieties demonstrated a continued productivity increase. Landrace cultivation has also shown unexpected multiplier effects, as shown in Figure 3.1. A majority of farmers in Lume and Gumbichu districts mentioned that local varieties provided additional livelihood benefits due to their reliability and low production costs. Landraces thus have a significant role to play in marginal farming systems, providing locally generated and sustainable solutions for improved food security, better livelihoods and agrobiodiversity conservation.

Figure 3.1 Comparison of local (landrace) and improved varieties of durum wheat in Lume and Gumbichu districts for yield potential in good, medium and bad years

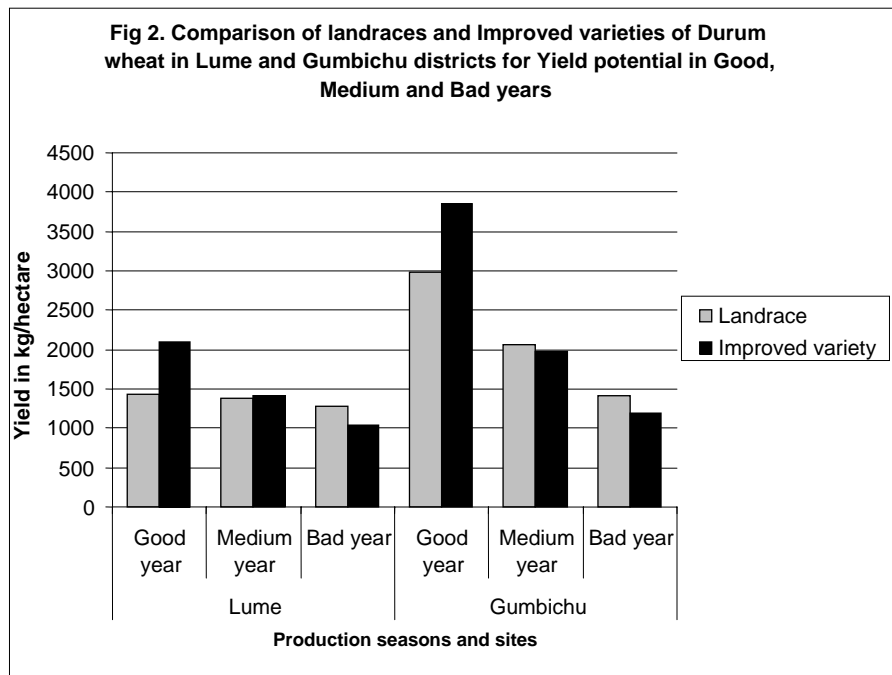

Mainstreaming the informal seed system in marginal production systems

Farmers have little or no genetic control over improved varieties, whereas they have long-standing knowledge of how to cultivate, conserve and use local varieties. Making the mainstreaming of local varieties a key feature of small-scale farming systems enables local farmers to retain shared ownership and control over the genetic base of their crops, and to breed and adapt their local varieties to suit highly heterogeneous agro-ecological field conditions.

One of the major problems hindering the implementation of biodiversity conservation objectives is clearly associated with lack of proper attention to the conservation of natural resources, including local varieties. Therefore, all development activities should pay maximum attention to the conservation and sustainable use of these resources. This can be achieved by raising public awareness at all levels and by courageous implementation. The national constitution recognizes the need for the conservation and sustainable use of resources. The interpretation of this legal provision as related to biological diversity is left to federal and regional public agencies and to private agencies involved in economic development activities. While this may be appropriate as a general legal framework, there is a need for a process that ensures correct application of this provision at operational level.⁶⁴ The development and implementation of programs for the conservation and rational utilization of biological diversity should be coordinated in order to avoid duplicating resources, manpower, and material. To this end, a coordinating mechanism should be put in place.⁶⁵ The overall economic development effort tends to be more geared towards increasing agricultural production and productivity exclusively through the generation and dissemination of high input technologies and practices.

Complementarities exist between progress towards increasing agricultural productivity through modern technologies (improved uniform varieties and inorganic fertilizers) in optimum potential areas, and progress towards achieving better household food security in marginal agricultural areas through traditional technology (genetic enhancement of local varieties) by promotion of improved organic farming techniques. The current seed policies serve the formal seed system at large. Therefore, appropriate policy, law and regulations need to be in place to promote wide acceptance of the informal seed system, especially in the marginal agricultural production systems.* A policy environment that mainstreams the informal seed system, integrating it into the extension service, is of paramount importance.

Concluding remarks

Local varieties have multiple benefits, including low input requirements, superior culinary and nutritional qualities, and specific adaptation to marginal areas with little or no access to chemical fertilizer inputs; these have all contributed to the continued cultivation of local varieties. In general, improved varieties do not meet farmers' diverse culinary needs; nor are they adapted to specific local environmental niches. In our studies, we have seen farmers' management practices – including seed selection,

* Creating enabling policy frameworks supporting informal seed supply is discussed in Chapter 7 of this book.

seed exchange, and seed storage and use – influencing genetic diversity of landrace populations. Like many other countries in the world, Ethiopia faces changes that disrupt the social and ecological conditions underlying farming practices, including the local seed system. Conserved local varieties serve as a gene pool for farmers to select desired lines to meet their changing needs. For reasons related to conservation, economics, and social and environmental considerations, then, the informal seed system and its local varieties should be supported.

3.5 Role of community gene/seedbanks in the conservation and use of crop genetic resources in Ethiopia

Johannes M.M. Engels, Severin Polreich and M. Ehsan Dulloo

Ex situ conservation of genetic resources plays a critical role in ensuring that threatened genetic resources are safeguarded for future improvement of crops, and contributes to rural peoples' livelihoods. However the present set up of *ex situ* conservation facilities does not allow easy access to conserved materials. Weak linkages between genebanks and users at all levels, i.e. very limited access to conserved material and related information, hamper or even hinder the sharing of benefits deriving from such conservation actions. It is crucial to improving farmers' access that national genebanks develop strong linkages with stakeholders, at the community level in particular. Although stronger involvement of stakeholders in the conservation activities has been emphasized in, international conventions such as the Global Plan of Action of the Food and Agriculture Organization of the United Nations, farmers' groups and non-government organizations (NGOs) are frequently underrepresented in plant genetic resources conservation and use programmes. Activities of farmers and rural communities are decentralized and uncoordinated by their very nature, frequently resulting in weak and/or non-existent links to formal governmental or public institutional activities. In recent years, NGOs have increasingly assumed a role in facilitating linkages, but usually in an informal and sometimes haphazard way.

Farmers are increasingly recognized as stakeholders in conservation, as they possess the knowledge of cultivating and using their traditional crops and landraces, (hereafter called traditional varieties), which are usually well-adapted to the local conditions. Farmers are critical in the process of conservation; crops are not a result of environmental factors only, but also of human selection. Farmers' decisions define whether particular populations of traditional crops are maintained or disappear from their fields. Consequently, participatory plant breeding, on-farm and/or farmer-level seed production, and support to farmer-to-farmer seed exchange implemented by national research programmes are important in the conservation of traditional varieties on-farm. These activities can also play a key role in establishing or improving linkages between the formal *ex situ* conservation activities and farmers' use of genetic resources. Farmers need reliable access to adequate genetic diversity for the crops they grow. Moreover, they should also be encouraged to maintain a diversity of both crops

and crop varieties, as this seems to provide a yield security against unexpected developments. By enforcing farmers' management and increasing farmers' access to genetic resources, these activities strengthen the dynamic nature of farmers' management of traditional resources and thus contribute to *in situ* conservation.

Community genebanks and seedbanks

The typology of community genebanks and community seedbanks is rather confusing, and little has been published in the scientific literature. A fundamental distinction exists between them. A community seedbank is operated as a collective seed store. We consider it an 'organized seedbank' as it primarily serves as a source of seed for the purpose of crop production. A community genebank, however, is an organizational unit that provides genetic diversity maintenance services to the farming community. It serves as a backup system for a wide range of local varieties and other materials. Hence, the amount of seed per sample provided to farmers is usually very small compared to what is usually distributed from a community seedbank. The diversity of crops held in a genebank collection is usually quite large since its target is to contribute to the conservation of genetic diversity rather than to economic development or directly to crop production. However, there are many situations in which these two objectives are combined and the role and functions of the 'bank' that caters for varieties or seed is a 'hybrid' of a community seedbank and a community genebank. In the rest of this section we will use the term community gene/seedbank to emphasize this hybrid nature.

Community gene/seedbanks are proposed in Ethiopia^{*,65,66} and many countries[†] as a strategic instrument to foster the farmers' management of local crops, to support the informal seed system and to support linkages with the formal sector, in order to enable the formal seed system to deliver services to the informal one, among other aims. In a way, the community seedbanks and community genebanks compensate for the weaknesses of both the formal and informal system: they complement each other, and they can contribute to the improvement of farmers' livelihood as well as to the conservation of genetic resources at the community as well as the national level.

Using the Ethiopian example, the present section analyses the potential of community seed/genebanks for contributing to efficient and effective conservation, and facilitating the use of traditional genetic resources. It is based on a survey conducted in Ethiopia during the harvest time of the 'Meher'-season from December 2004 to March 2005 as part of an MSc thesis field research project by the second co-author. Four districts were visited, three with community gene/seedbanks – Gimbichu, Lume (both in East Shewa), and Wore Ilu (South Wollo), and one without a community gene/seedbank – Qimbibit (North Shewa). All the districts are located in the main wheat-growing areas of Ethiopia, which is considered as a secondary centre

* In Section 3.4, Girma Balcha and Tesema Tanto describe how community genebanks are part of the national strategy to conserve and use plant genetic resources.

† In Section 2.4, Pitambar Shresta and colleagues describe experiences with community seedbanks in Nepal.

of diversity for tetraploid wheat. About 100 wheat growing farmers, both community gene/seedbank members and non-members were interviewed with semi-structured questionnaires. The aim was to reveal farmers' perceptions of participation in community-based wheat germplasm conservation activities, and the overall acceptance of using local wheat varieties for improved wheat germplasm.⁶⁷

Organization of community gene/seedbanks

A typical community gene/seedbank in Ethiopia can best be described focusing on the following organizational and managerial aspects. The Institute of Biodiversity Conservation (IBC) in Ethiopia has supported the establishment of twelve community gene/seedbanks in different districts.⁶⁸ They function according to individual rules and decisions that have been set by the association of voluntary crop conservator farmers (i.e. members of a Crop Conservation Association, CCA). The community gene/seedbank is owned and managed by respective local communities. Currently, four of the twelve such associations are officially registered and in the process of acquiring legal entity status (Table 3.6).

Table 3.6 Characterization of community seedbanks/genebanks and Crop Conservation Associations by the Institute for Biodiversity Conservation in Ethiopia⁶⁴

<i>Region</i>	<i>Location</i>	<i>District</i>	<i>Number of members</i>	<i>Legal organization</i>	<i>Number of crop types</i>	<i>Amount of seed in kg[¥]</i>
Amhara	North Shewa	Ankober	88		2	2,360
Amhara	North Shewa	Insaru Wayu	66		5	1,320
Amhara	South Wello	Kallu	223		3	8,668
Amhara	South Wello	Wore Ilu	362		8	9,815
Oromia	East Shewa	Lume	1000	√	7	36,300
Oromia	East Shewa	Gimbichu	300	√	4	36,300
Oromia	Bale	Agarfa	96		3	3,169
Oromia	Bale	Goro	101		5	1,953
SNNPR	Keffa Sheka	Decha	226		5	12,978
SNNPR	Keffa Sheka	Chena	297		6	14,650
Tigray	East Zone	Hawzen	300	√	11	6,993
Tigray	East Zone	Ganta	300	√	9	2,436
		Afeshum				

Notes: SNNPR = Southern Nations Nationalities and Peoples' Regional States; ¥ purchased from farmers; √ = CCAs are legally recognized.

According to the IBC, a community gene/seedbank acts as a link between the National Genebank, local staff and the association members, the latter being the farmers. The community gene/seedbank is managed by an elected Central Committee of the CCA. They are assisted by local staff (extensionists) from the Bureau of Agriculture and Rural Development (BoARD) and Cooperative Support Agency (CSA). The Central Committee coordinates training programmes, administers and records seed exchanges between the bank and farmers, and organizes farmer varieties

purchases. Members assist in the multiplication and collection of farmer varieties. Special sub-committees for credit and an inspection committee have been established, that are responsible for the allotment of seed credits and the control of seed exchange, respectively.

The seed exchange among farmers and community gene/seedbank usually occurred according to fixed protocols and rules that were determined by the respective CCA. In Gimbichu, farmers had to pay a registration fee of 5 ETH Birr (@0.5 US\$), before they could buy up to ten seed shares (one share = minimum 25 kg, maximum 200 kg of seed) at an interest rate of 20%. Depending on the number of seed shares, the proprietor could take the seed or provide it to other CCA members (farmers) who had to return it by adding 20% of the borrowed seed shares. This means, for example, that a farmer who borrowed a share of 50 kg seed had to return 60 kg of the same wheat.⁶⁹ The interest rate is decided by individual CCAs. For example, in Wore Ilu in 2004/5, the interest rate was only 10% of borrowed seed shares. Farmers who wanted to become CCA members first had to contribute one share of seed of a farmer variety (10 kg) purchased or produced by themselves and to pay a registration fee of 2 ETH Birr.⁷⁰

Assessing community gene/seedbanks' contribution to conservation

The Ethiopian study revealed a number of general characteristics of community gene/seedbanks in contributing to conservation and use of genetic resources at the community level, and provides a model for the linkage between national genebanks and local communities. Community gene/seedbanks have several functions at the community level. These can be summarized as follows: (i) providing a framework for community organization; (ii) safeguarding against crop failure and local variety seed loss; (iii) contributing to on-farm conservation; (iv) documenting information on genetic resource at local level; and (v) providing a linkage to market and consumer preferences.

Community gene/seedbanks as community organizations

First and foremost, community gene/seedbanks provide a framework for bringing together the members of a local community who share common problems in safeguarding their local diversity and accessing adequate supplies of seeds for their needs. Generally, once a farmer has substituted a local variety in his/her field it often becomes difficult to retrieve it if no action has been taken to conserve the variety. In most cases, such conservation actions are undertaken by national plant genetic resources programmes, and materials are stored in *ex situ* genebanks, usually operated by the formal public sector in a given country, and the material is often not easily accessible. An example of how community gene/seedbanks can increase the accessibility of farmers' varieties or landraces can be demonstrated by the case of Gimbichu and Lume, both districts close to Addis Ababa and therefore more exposed to commercial influences than other regions in Ethiopia. Almost six years after the establishment of the community gene/seedbanks, more than 70% of the wheat producers growing wheat landraces indicated that the community gene/seedbank was the original source for their local varieties, while few alternative sources were

mentioned. Therefore, establishing a structure at local level may facilitate access to local germplasm, but it is essential that links between the formal and informal sectors are established too. Monitoring and control of quantities and quality of seed by professional staff during the process of seed exchange helps to maintain quality seed; it also contributes to equity among community members requesting access and seed. Lack of stakeholder cooperation and coordination is a common problem many projects supporting community seed/genebanks face. Communities like Lume that have to deal with larger number of members (Table 3.6) will not be able to effectively monitor and document seed exchange without the assistance of formal research centres. For example, a generally decreasing trend of seed exchange occurred in the CCAs concerned (Figure 3.2). This trend was more drastic in Lume, whereas in Gimbichu the number of farmers obtaining wheat seed from the community gene/seedbank remained constant between 2002 and 2003. In Wore Ilu, the number of CCA-members exchanging seed stagnated after 2002, while the seed amount decreased.

In Gimbichu, a higher share of seed per farmer was observed, because the number of farmers borrowing seed in 2004 decreased by 70% compared to the season before. In the year 2003, a total of 461 farmers took about 32 tons of seed, while in 2004, 112 farmers took less than 24 tons. About 34 tons of wheat was returned to the seedbank in 2004. However, for a seed loan at the rate of 20% per 50 kg seed decided by the CCA in Gimbichu, at least 39 tons of seed should have been returned by farmers. As in Gimbichu, the seedbank of Wore Ilu was visited by fewer farmers than in the previous years too, and the amount of wheat seed stored in the seedbank decreased. In 2001, 136 farmers had to share more than 4 tons of wheat seed, while in 2003, only 66 farmers had obtained around 2.5 tons. Less than 50% of the seed distributed in 2003 had been brought back to the community gene/seedbank. Nevertheless, just two farmers did not return any wheat seed at all. Less than a quarter of the seed borrowed in 2001 was returned in 2004 to the seedbank of Wore Ilu.

The administration of banks that cover a number of widely spread communities is complicated. A large bank and geographic area can result in farmers with different perceptions and attitudes to joining, and reluctance to compromise. Within districts, opinions may vary about aspects of the operation such as seed treatment and quality considerations. A critical issue in this context is the fact that not all members received the same training in seed management and other aspects of the operation of a community bank. For instance, some farmers continued with seed management practices that are considered unsuitable for community gene/seedbank management. This complexity is directly linked with organizational aspects of establishing the associations, where communication and coordination capacities become key issues. Other complexities emerge when specific seed practices cannot be carried out due to shortage of labour, power and space. This mainly affects poorer farmers joining the associations.⁶⁷

Figure 3.2 Wheat seed exchange with the gene/seedbanks of three districts in Ethiopia from 2001 to 2004, a) Share of farmers participating in the seed exchange, b) relative amount of wheat seed exchanged ⁶⁷

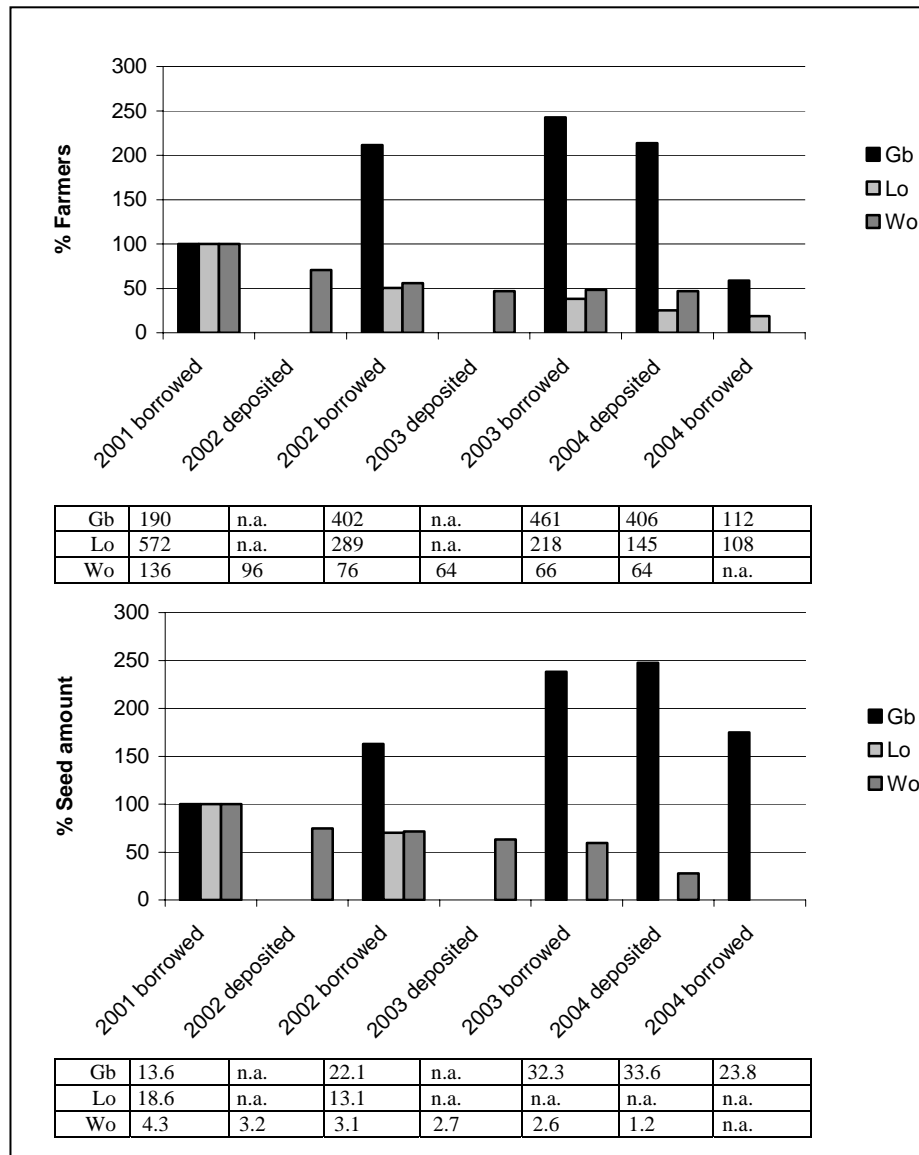

Note: Values in table: a) total number of farmers exchanged wheat in the respective year, b) total amount of wheat seed (in t), exchanged in the respective year. Gb=Gimbichu, Lo=Lume, Wo=Wore Ilu; n.a.= not available. Data source: seed distribution and exchange recordings from respective CCAs of the districts Gimbichu, Lume, and Wore Ilu.

Safeguarding against crop failure and local variety seed loss

A community gene/seedbank may play an essential role in preventing the loss of genetic resources from farmers' fields. The multiplication of local varieties is often vulnerable to occasional crop failures. Post-harvest losses are also important threats, since they may particularly affect accessions with special traits. Post harvest losses may also occur due to accumulated debts that force poorer farmers to sell their seeds, or due to storage problems or famines, when seed reserves are consumed. A permanent backup within the community gene/seedbank and national *ex situ* genebank are necessary in order to safeguard local varieties from loss. The establishment of strategic seed reserves of local varieties and other germplasm adapted to local conditions was proposed by the predecessor of the Ethiopian Seed Enterprise during the main drought period of the early eighties, and user-friendly protocols for conservation and regeneration were proposed to local communities. This example serves to illustrate the value of conserving local genetic diversity. However it is important that the capacity of local community managers is adequately strengthened. Experience with the community gene/seedbanks in Ethiopia shows that communities should be trained to overcome the technical difficulties that can be encountered at the farm level (in addition to the bank level) while managing their local varieties.

Contributing to on-farm conservation

Community gene/seedbanks can serve as an interface between farmers' efforts to conserve their local varieties on-farm and the formal *ex situ* conservation facilities. To realize reliable and continuous on-farm conservation, the responsibility should not only be allotted to farmer's communities but also to the formal sector. Community gene/seedbanks can provide the platform for interaction between plant genetic resources, professionals and farmers to exchange information about on-farm conservation processes, including traditional knowledge in the cultivation of local varieties. This requires closer cooperation between public research institutes, breeders and farmer organizations.

Generally, farmers appreciated community gene/seedbanks not only as seed source but also as meeting points where they could exchange and obtain information with other farmers who were growing the same or similar traditional crops or cultivars. Further, a seed store, outside of their farm, helped them to retain seeds for the next cropping season, which otherwise could be used up due to shortage of food or repayment of debts. In fact, the community gene/seedbanks of Gimbichu and Lume contributed to a temporal broadening of the intra-specific variation, by spreading landrace composites. There seemed to be a particularly strong relationship between the CCA membership of the farmer and the maintenance of local varieties on-farm (Table 3.7).

Table 3.7 Factors affecting wheat diversity measured in richness of varieties (N), Shannon-Wiener Index (H), and Evenness (H') in four districts in Ethiopia, 2004-2005 ⁶⁷

Distr.	Index	Explanatory Variable						R ²	Number observed
		TLU	Ha Tot	Importance of wheat	CCA-membership	Distance to market	% yield sold in market		
Gb	N _{LRs}	-.347**	-.216	.243	.738***	.110	.067	.517***	28
	N ^y	.672***	.305*	.145	.070	.093	.085	.731***	28
	H	.537***	.302*	.368***	-.051	.037	.181	.711***	28
	H'	.390*	.074	.255	-.083	.232	.158	.150*	28
Lo	N _{LRs}	-.032	-.088	.032	.518**	-.068	-.082	.158**	17
	N ^y	-.140	.697***	.277	.161	.098	-.132	.486***	17
	H	17
	H'	17
Wo	N _{LRs}	19
	N ^y	19
	H	19
	H'	19
Qi	N _{LRs}	-.056	.175	.431**	-	-.002	-.027	.186**	29
	N	.200	.291	.558**	-	-.021	-.130	.311**	29
	H	-.173	.375*	.641**	-	.187	.027	.379**	29
	H'	.	.	.	-	.	.	.	29

Notes: Gb=Gimbichu, Lo=Lume, Wo=Wore Ilu, Qi=Qimbibit; N_{LRs}= number of traditional farmer varieties, landraces; N^y= number of improved varieties; TLU = tropical livestock units, equivalent to a livestock weight of 250kg: ox=1.1, cattle=0.8, horse=1.3, donkey=0.35, sheep=0.08, and goat=0.07; HaTot= total land size available on farm households; * statistically significant at p≤0.05 level; ** statistically significant at p≤0.01 level; *** statistically significant at p≤0.001 level. The factors were analysed by using a stepwise multiple regression. All presented coefficients are standardized values.

However, the primary goal of farmer-based conservation is not only to increase the diversity but also to support processes that generate new germplasm in a relatively natural way. How farmers actually can contribute to the dynamic processes of *in situ* conservation is illustrated by an example of the Chefe Donsa CCA in Gimbichu. Although all wheat landraces had formerly been distributed in equal quantities,⁷¹ the seed amounts of some populations of local varieties, for instance 'INS1' and 'RD-OB-PS1' had been increased (Figure 3.3).

The interviewed CCA members assigned better properties to those varieties than they did to other local varieties: these properties included relatively good yield, tolerance to frost, water shortage and water-logging conditions in the soil, as well as resistance to rust. However, further research coordinated and carried out by the IBC should analyse in detail whether the seed amounts of certain varieties really decreased due to less adaptive traits, or due to mistakes in seed management.

Figure 3.3 Mean relative frequency of wheat varieties distributed to farmers from the community gene/seedbank Gimbichu during two cropping seasons 2003-04 ⁶⁷

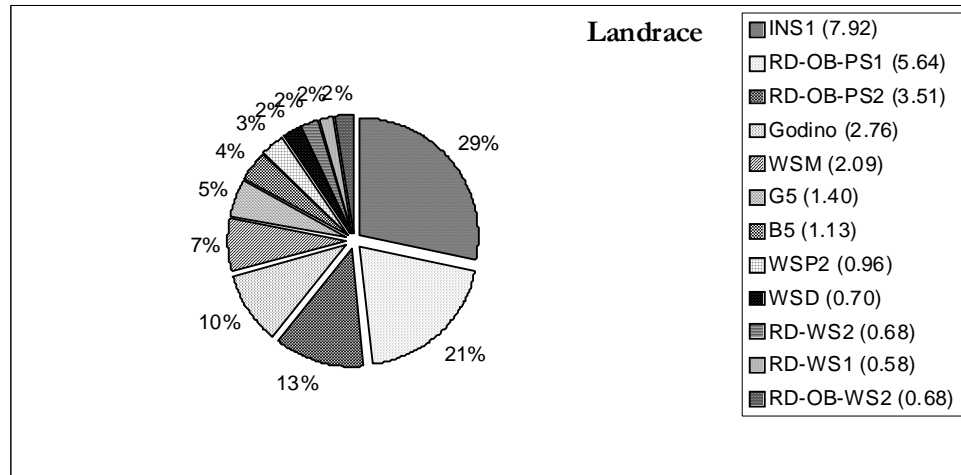

Note: The mean amount of wheat seed per landrace distributed to CCA-members (in t) is indicated in brackets. Data source: seed distribution and exchange recordings from the Chefe Donsa CCA, Gimbichu

Documenting information on genetic resources at local level

Both the establishment of detailed databases on community gene/seedbank entries and information about post-harvest traits are crucial for goal-oriented conservation and for crop improvement. Detailed data of redistributed local wheat varieties from the community banks in Gimbichu and Lume are still not accessible for conservation professionals or other genetic resource users. Vernacular names of local varieties are important signals as to the availability of adaptive or yielding attributes.⁷² Neither vernacular names nor collection numbers of the redistributed populations in Gimbichu and Lume were linked adequately to the IBC-conserved accessions of the same material through the passport data. In addition, the databases established and maintained by the IBC did not include indigenous knowledge, on-farm evaluation and characterization data. Therefore, the material that is maintained in and cultivated through the community gene/seedbanks is not really accessible for other users within the formal system; moreover, the material is primarily available within the local informal seed system with its usual restrictions. Furthermore, the establishment of a community biodiversity management trust fund would present an additional motivation for the community to continue with collective biodiversity management activities.* Detailed documentation and better access to information about local varieties in well organized databases such as community biodiversity registers might stimulate breeders to cooperate more closely with farmers. They might only be convinced by goal-oriented conservation and the development of crop genetic

* The trust fund is part of the strategy to support community biodiversity management as described by Sthapit and colleagues in Section 3.6.

diversity through local structures such as the community gene/seedbanks or platforms if the dynamic aspect of on-farm conservation is clearly depicted.

Providing a linkage to market and consumer preferences

The success of any community gene/seedbank depends on its financial viability. Various farmer associations in Ethiopia have to contend with low or negative cost benefit ratios. Although community gene/seedbank projects are often described as a low cost and low technology system with genebanks owned and managed by local communities,⁷³ in their current structure their viability is not likely to result in continued cultivation of traditional crops and local varieties, nor to facilitate active and sustained seed exchange of local varieties among farmers without external financial incentives. Upon the recognition of the association in Lume and Gimbichu, financial support was discontinued; consequently, the control and distribution of seed was reduced. Control mechanisms are essentially of a 'voluntary' nature. This has a negative effect on the quality of control and may leave space for corruption, causing mistrust among members and slowing down seed exchange.

Farmers need to be compensated more adequately for their contributions to conservation, especially when they provide targeted inputs, crops or varieties of a lower value to them, which would otherwise naturally have a lower priority in their production agenda. Without markets for the traditional crops or varieties produced in areas with community gene/seedbanks, the related activities may not be sustainable.⁷⁴ A lack of markets for local wheat varieties was one of the main arguments for Ethiopian farmers to drop the cultivation of local varieties, although their qualitative properties were more highly valued than those of improved varieties. Raising public awareness through detailed information on the advantages of local varieties to be conserved on-farm over improved varieties could increase the market value for urban markets and food processing industries. For example, to increase the competitiveness of local durum wheat varieties, superior varieties were bulked into elite composites with similar agro-types and tested in field trials at the Debre Zeit Research Centre, Ethiopia. Under sub-optimal growth conditions, the yield potential of these composites equalled or surpassed that of commercial high-yielding varieties.⁷⁵ The local durum wheat composites were redistributed through community gene/seedbanks in Gimbichu and Lume.⁷¹ They are characterized as having a similar growth behaviour appearance and post-harvest properties to local varieties. However, due to their dark seed colour, they were less favoured by both merchants in the markets and consumers in the nearby towns. Farmers therefore preferred to grow marketable varieties that were mainly exotic hexaploid bread wheat (from CIMMYT) with white seed colour or improved amber coloured durum wheat varieties. However, according to farmers' perceptions, the quality of those exotic wheat types for food purposes was lower than that of their local varieties. Commercial wheat types with lighter seed colour may be cultivated less in remote areas, where the market structure is less developed and farmers' income depends less on sales to merchants and the food industry. This experience with durum wheat varieties illustrates the importance of choices of varieties and also the involvement of other stakeholders than farmers in

trying to promote the use of the local varieties that are being redistributed through community gene/seedbanks.

Community gene/seedbanks as a basis for community conservation platforms

The community gene/seedbanks and their Crop Conservation Associations discussed in this section may appear to be too restrictive in their set-up and biased towards conservation purposes, without recognizing development opportunities. It is therefore proposed to transform them into community level Community Conservation Platforms. Such platforms could contribute to rural development by increasing seed security through linking formal and informal seed supply and conservation approaches. Sthapit and colleagues* suggest that development through community biodiversity management (CBM) should address social community development issues instead of focusing only on biodiversity conservation practices. Community gene/seedbanks support farmers' agrobiodiversity management through seed exchange, processing and storage. The platforms may facilitate communities' dialogue with researchers to decide which crop to multiply, maintain and search for other materials. Instead of the direct seed exchange between the community gene/seedbanks and individual farmers which is the current practice in Ethiopia, the amounts of seed demanded by the farmers should be provided as far as possible through the platform. This will reduce the administrative work of the Central Committee and facilitate the flow of information between the association and other farmers in the community. As mentioned earlier, when only a few farmers per village have access to the community gene/seedbank storage facility, informal systems are often channelled through social relations and some community members may remain uninformed. By focusing on the strengths of informal seed supply instead of on continuous storage, the platform could aim at a constant circulation of local variety seed in the villages, while a smaller amount is kept as a documented back-up in the community gene/seedbank storage facility. This approach would better match and stimulate the dynamic nature of farmers' management of local varieties.

* See Section 3.6.

3.6 Mobilizing and empowering communities in biodiversity management*

Bhuwon Sthapit, Pratap Shrestha, Abishkar Subedi, Pitambar Shrestha, Madhusudan Upadhyay and Pablo Eyzaguirre

Community Biodiversity Management (CBM) is a community-driven participatory approach that empowers farmers and communities to organize themselves and to develop strategies and plans that support on-farm management of agricultural biodiversity. This approach is based on the fact that the maintenance of a large diversity of landraces depends on farming practices driven by farmers' own customs, traditions and livelihood needs – all of which affect the movement of seeds among households, within and among villages, and in a larger geographic area. CBM strategies can be used to strengthen farmers' seed systems by improving access to diversity and by recognizing and reinforcing the farmers' role as plant breeders. This method results in the community taking more control of their resources, with increased ownership for the on-farm conservation and sustainable livelihood options, and with carefully selected and appropriate external inputs and risks. The CBM approach helps to facilitate social processes that contribute to the conservation and utilization of biodiversity.

CBM as an integrated approach to conservation and development

The CBM approach integrates knowledge and practices with social systems; local rules of institutions drive it (Figure 3.4). This approach can be realized by empowering communities and their institutions from the outset, building upon an analysis of sustainable livelihood assets for reducing poverty and social injustice. The key is to institutionalize local level decision-making.⁷⁶ As an integrated conservation and development approach, CBM reinforces the capacity of farming or user communities and their institutions. The focus is on increasing decision-making power and securing community access to and control over the resources required for community biodiversity management. The key elements of CBM include: (i) knowledge about biodiversity and associated landscapes, (ii) social systems facilitating maintenance and exchange of their genetic resources, (iii) local institutions that support and govern local management and access to biodiversity, (iv) technologies, processes and practices that add value to local genetic resources, (v) local financial resources such as group savings and credits to ensure continuity, and (vi) necessary linkages to appropriate institutions which will sustain the access to livelihood assets. CBM is a process-led approach and builds on farming/user communities' existing capacities and committed policy support. Such an approach has often been complicated by local level power relations; a committed local NGO needs to build capacity, facilitate and mentor decision-making processes and reinforce local institutions until they are fully equipped

* Section derived from a paper published in Sthapit, B.R., P. Shrestha, and M. Upadhyay (Eds.), 2006. Good practices. On-farm management of agricultural biodiversity in Nepal. Kathmandu, NARC, LI-BIRD, IPGRI and IDRC.

to autonomously facilitate community-based decision making. Such decision making is the aim of the community empowerment required to realize community management of biodiversity.

Figure 3.4 Key elements of the community-based biodiversity management model for connecting biodiversity knowledge and decision making through community empowerment and social inclusion⁷⁶

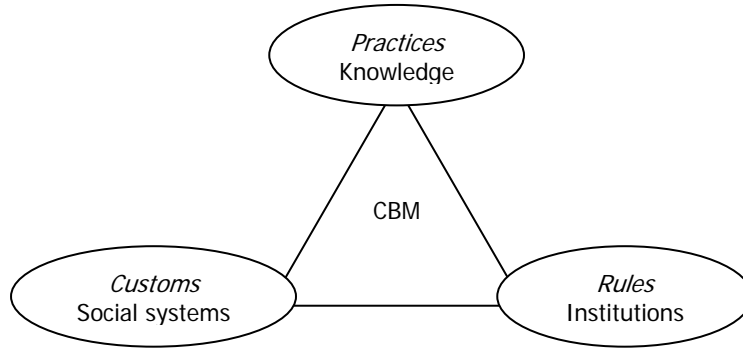

Steps for establishing CBM

Experience in Nepal has shown that the following steps are involved in establishing and promoting the CBM approach to managing biodiversity by collective community action:

Step 1. Enhancing community awareness

A village workshop is organized in order to create awareness among the community members. Together with representatives of local stakeholders, they will discuss conservation needs, identify their roles and responsibilities, and understand and identify their own working modalities. Based on these discussions, various sub-committees are formed to plan and implement awareness activities such as biodiversity fairs,* food fairs, rural drama, rural poetry journeys, cultural folk song competitions, rural radio, exchange visits and so on.

Step 2. Understanding local biodiversity, social networks and institutions

A participatory assessment of agricultural biodiversity is conducted using participatory four-cell analysis, in which community members and the partner organizations identify common, unique and rare plant genetic resources. They gain a better understanding of the farmers' rationale that determines the extent and distribution of local crop diversity, and they identify the biological assets that play vital roles in the livelihoods of local people. Ultimately, the tool enables the participants to develop diversified livelihood options and community-based conservation strategies. A second tool that can be used in this step is social seed network analysis. This tool is used to identify

*Tools supporting community biodiversity management are described by Bhuwon Shapit and colleagues in Section 3.7

nodal farmers who play major roles in the informal flow of genetic materials, as well as the related knowledge both within and beyond the farming community.⁷⁷

Step 3. Capacity building of community institutions

Community institutions, including farmers' groups, are identified and their activities and innovations related to the management of community genetic resources are assessed. The information gathered will contribute to the planning of local institution capacity building. A SWOT (strengths, weaknesses, opportunities and threats) analysis of community-based organizations is conducted; this helps to identify the capacity building needs of these institutions and at the same time identifies the local institutions that will coordinate biodiversity management. Forest users groups could be mobilized for non-timber forest products management, wetland user groups for fishery management etc. For this village-based training and orientation, programmes are organized to pass on the knowledge and skills to assess their own needs, define their priorities based upon available resources, prepare need-based work plans and facilitate wide community member participation in decision making and management processes. This step focuses on capacity building in analysis, to increase the efficiency, self-confidence and social mobilization capacity of local institutions. For example the community-based organizations facilitating CBM in Nepal have developed the capacity to establish locally driven guiding principles and codes of conduct for community biodiversity management, and to organize community biodiversity access and benefit sharing.

Step 4. Setting up of institutional working modalities

Key institutions are identified for the coordination; their roles and responsibilities, and institutional norms are defined. A work plan is prepared and community level indicators for performance monitoring are identified. A CBM Committee is established within these local institutions in which members of the farming community and the community-based institution are represented. The Committee will coordinate and oversee the implementation of CBM strategies and plans. It also enforces the codes of conduct established for the management of community genetic resources (Box 3.1). The Committee's capacity is further strengthened in establishing institutional linkages with and seeking resources from service providers outside the community.

Box 3.1 Guiding principles of CBM developed by local institution in Begnas village, Nepal

- Each member should exchange at least two landraces per year
- Each member should participate in the group saving and credit programme
- The participating members should use organic fertilizer and minimum pesticides to protect associated biodiversity and pollinators
- The community should maintain a community biodiversity register locating seed sources, documenting traditional knowledge, and facilitating joint learning
- Priority should be given to the poor, women and disadvantaged members of the community in CBM plan implementation

Step 5. Consolidating community roles in planning and implementation

The community members are encouraged to assume responsibilities in CBM. This is facilitated by a bottom-up approach to the work plan. The CBM Committee coordinates various farmers' groups to develop annual action plans through a village meeting. Capacity building activities by the committee members and community-based organizations support this community level planning process.

Step 6. Establishing a CBM Trust Fund

The following step is to identify the financial resources required to purchase the necessary services. A CBM Trust Fund is created as an integral part of the CBM approach. Within the project in Nepal where this approach was developed, seed money from an international project contributed to the establishment of this fund. It is now managed by the CBM Committee in the form of a 'saving and credit' scheme under which community members receive credit for conservation-oriented activities. The interest generated by these investments contributes to the increase of the fund and is also utilized to cover its management. The fund can be integrated within the genetic resource access and benefit sharing scheme, where a portion of the benefits accruing from the use of community genetic resources can be inserted into it and can later be used for the welfare of the community concerned. The CBM Trust Fund has been found to be an effective means in organizing community members, developing community ownership and motivating the community and their institutions to implement CBM action plans. It is important to strengthen the capacity of the CBM Committee to manage such a fund, as its existence becomes a motivating factor for collective actions in the community and contributes to institutional sustainability.

Step 7. Community monitoring and evaluation

Monitoring and evaluation indicators are identified and the procedures for monitoring progress against these indicators are agreed upon in a consultative process. Within the project in Nepal, the CBM committee has established an annual CBM calendar encompassing all priority action plans that include participating institutions' and community members' roles and responsibilities. This CBM calendar is not only helpful for reviewing and monitoring progress, but it also promotes transparency within the community and among the institutions involved. Review meetings and travelling seminars are regularly organized to monitor and evaluate community actions.

Step 8. Social learning and scaling up for community collective action

The final step of the entire process entails scaling up of the good CBM practices. At the local level this means supporting the involvement of a larger number of households within the community and of other farming communities adopting/adapting similar practices. Annual or bi-annual social learning meetings can be organized to review the progress, share successes and failures, and identify innovations and new practices that can be scaled up to other households and communities. Other means of facilitating collective learning include community wall magazines, rural radio programmes, biodiversity fairs, and farmers' travelling and learning workshops. The synthesis of social learning and good practices can be used to

inform policy makers and influence the creation of policy environments that support CBM as an approach that integrates conservation and development.

Lessons learnt from working with CBM in Nepal

Community empowerment and effectiveness are difficult to measure as their assessment is subjective and qualitative in nature. Experiences working with the outlined CBM approach in Nepal show that it has been quite effective in empowering farming communities to organize and act collectively, planning and implementing activities that target biodiversity conservation and utilization. In two sites, communities got involved in establishing a community biodiversity register and community seedbanks, working with diversity blocks, enhancing the production and marketing of seeds of local crop varieties, and adding value to local variety and minor crop products through processing and marketing. These practices have been fully institutionalized within community level organizations. Participatory landrace selection and participatory plant breeding methods have been used to improve the competitiveness of landraces. Table 3.8 illustrates the driving forces behind some of interventions tested.

Table 3.8 Good practices for CBM in Nepal

<i>Good practices for collective actions</i>	<i>Driving forces</i>	<i>Conditions favouring success</i>	<i>Conditions hindering success</i>
Diversity fair, community biodiversity register, traditional knowledge journal	Information and genetic resource access, learning, ownership social connection	Empowerment, policy support, demonstrating benefits	Reliance on donors' short-term interest
Community seedbank, diversity block	Social recognition, collective action for landrace conservation	Existence of social and human capital for maximizing farmers' interest in learning and innovation	Emphasis on commercial success
Value addition and supporting market chain linkages	Income generation through market access for local crop products, link to relevant stakeholders	Well-linked commodity chains; value addition capacity of collective actions; CBM funds	Specialization in few varieties or crops demanded by markets
Local crop development including landrace enhancement and participatory crop improvement	Specialized learning, access to preferred traits and diversity	Empowerment; improving access to crop diversity	Lack of supportive policy from private sector, national and international research organizations

The CBM committees and local community-based organizations have evolved and are effectively coordinating CBM. The Trust Funds have also been established and are effectively being used for the benefit of community members. The CBM programme has also increased the active participation of socially excluded, poor and marginal women farmers; Women who never participated in public meetings or expressed their opinions now access seed and small credits, without having to deposit any collateral.

They also benefit from CBM through purchasing goats, poultry and agricultural inputs. The CBM work of the farming communities and their representative community-based organizations is increasingly being recognized by local government, civil society organizations and international institutions. Policy makers are now listening to the voice of farmers in meetings addressing the conservation of agrobiodiversity. Consequently, farmers' and rural institutions' ability to establish linkages with various institutions, and to generate resources for community-based rural development programmes, has been identified as an important indicator of community empowerment.

CBM as a participatory approach empowering communities in conservation

CBM is a participatory approach aiming to empower farmers and local institutions to capitalize on their biodiversity assets in order to benefit their communities and overcome poverty and environmental degradation. The approach links conservation and development objectives: it fosters a respect for agrobiodiversity, and biodiversity in general, and it also focuses on community issues and enhances community capacity to analyse livelihood assets and problems, and to seek and implement solutions. It recognizes and supports local institutions and communities as legitimate and crucial actors in the national plant genetic resource and seed system. Communities are empowered to exercise their rights and secure access to, and control over, their genetic resources. Local decision-making processes are central, and CBM therefore emphasizes local governance. The goal is to ensure that communities have the capacity to manage the agricultural biodiversity they depend upon in their livelihood strategy, and the influence to shape and adapt it to meet their needs and help them cope with changing socio-economic, biological and physical environments.

The initial results from the approach in Nepal show that it is effective in empowering farming communities not only to apply a wide range of practices for agrobiodiversity conservation and utilization, but also to raise other community and social-environmental development issues. The effectiveness of community-based institutions could be further reinforced by forging effective linkages and partnerships with research and development institutions. Such capacity building does not happen overnight; in fact it requires continuous engagement and backstopping, especially in financial and human resources management and in seeking funds to sustain and scale up activities. The establishment of the CBM trust fund is an important step towards community empowerment, which is the driving force in the CBM approach. Critical figures in the success of CBM are the change agents, who should have a culture of facilitating community empowerment.

3.7 Practices supporting community management of farmers' varieties

*Bhuwon Sthapit, Abishkar Subedi, Pitambar Shrestha,
Pashupati Chaudhary, Pratap Shrestha and Madhusudan
Upadhyay*

Community biodiversity management is an integrated approach that contributes to both the conservation of local crop genetic diversity and community development. Even though it is 'conservation oriented', it incorporates many features that are relevant to supporting the informal seed system, the topic of this book. A project in Nepal studied farmers' practices in maintaining and utilizing agricultural biodiversity, and went on to use participatory approaches to develop and test a set of tools for supporting community management: tools which are geared to conservation or diversity, and contribute to the maintenance of crop genetic diversity on-farm. Community capacities to manage and mobilize agricultural biodiversity are recognized as the basis for these tools, which we briefly describe in this section.

Tool 1: Community awareness

Community sensitization is essential to understanding farmer management and developing local strategies for the conservation and sustainable utilization of biodiversity. It raises awareness among farming communities, who learn about the value of local crop diversity. It strengthens community-based organizations' capacity and shifts behaviour towards conservation and diversity. Farmers' sense of pride in their cultural heritage is fostered as well. Various tools can be used, including the biodiversity and seed fair, the *teej geet* (folk song) competition, the rural poetry journey, the traditional food fair and rural roadside drama. These tools are people friendly and effective in giving rural people access to the required information. The choice of tools depends upon the cultural context of the community.

Tool 2: Biodiversity and seed fairs

The biodiversity fair is a popular tool for raising public awareness on the value of conserving local landraces. During a fair, farmers from different communities are brought together to exhibit a range of landraces; this continues the traditional system of exchange of seeds and knowledge. This participatory tool has been used for various objectives by a range of organizations.⁷⁸ In Nepal, biodiversity fairs are not only organized for promoting the exchange of knowledge and germplasm; they are also organized to explore diversity-rich areas and to recognize communities as custodians of traditional knowledge and biodiversity.⁷⁹ Participation in biodiversity fairs has become a matter of pride for the farming communities as they display their rich genetic resources and indigenous knowledge to visitors. It is one of the best forums for creating awareness and interest on the importance and value of local genetic resources amongst diverse stakeholders. Besides, it facilitates scientists, researchers, private entrepreneurs and policy makers to interact with communities and learn from

them. For genetic resource professionals and researchers, the fairs provide opportunities for collecting germplasm with communities' prior informed consent. The main steps in organizing the fairs include (i) participatory planning with key stakeholders; (ii) setting norms and procedures for the diversity fair; (iii) planning for implementation of the event; and (iv) participatory evaluation of the contest during which participants' displays are evaluated.⁸⁰ Diversity fairs organized by local institutions create ownership and develop local capacity to coordinate events involving various stakeholders; they also promote social interactions and awareness on the importance of biodiversity conservation.

Tool 3: Diversity blocks

A diversity block is an experimental block of farmers' varieties for research and development purposes managed by local institutions. The block is used for measuring and analysing agro-morphological characteristics but also for validating farmers' descriptors. A group of knowledgeable farmers is invited to observe the diversity block during cultivation. In this manner, researcher can observe whether farmers are consistent in naming and describing local varieties by farmer descriptors. This step is often ignored when assessing community level biodiversity richness. The block can also be used for the multiplication of planting materials, following cultivation of rare germplasm in the block. Samples multiplied can be shared in the community. Materials can also be supplied to *ex situ* collections, individual plants can be provided for parent selection in participatory plant breeding, and seed lots can be regenerated for community seedbanks. The diversity block has as an additional advantage of raising public awareness. A functional diversity block is established using the following steps:

1. Collect seed samples (50-200 g seed per variety' depending upon the crop) during for example a diversity fair; include essential passport data, e.g. variety name, farmers' descriptors, name of farmers, original habitat, name of locality and special use value.
2. Reiterate objectives and potential benefits from the diversity block and discuss with the community which local institutions would be interested to grow and maintain the block at a strategic and representative public place.
3. Orient community members to a simple field layout, planting and labelling, and identify a focal person for block management. It is essential to provide a conceptual and practical training to ensure proper handling and storage of seeds.
4. Use the farmers' management system for the block. If many entries are proposed, prioritize seed of rare, unique and threatened varieties for seed multiplication. The inclusion of these entries also serves to raise awareness of their potential values. The varieties with inconsistent names can be included in order to measure their distinct morphological traits and validate the names.
5. Install display boards with the purpose of the exercise and name of each individual variety.
6. Conduct a farm walk with interested and knowledgeable farmers, researchers and schoolchildren in order to:
 - promote the exchange of knowledge;

- recognize a variety through farmer descriptors;
 - test consistency of farmer-named varieties within and between communities and villages;
 - collect the seed potentially demanded for future planting (5-10 kg);
 - collect rare and unique seed for inclusion in *ex situ* collections;
 - regenerate seed for the community seedbank;
 - identify plants for participatory plant breeding; and
 - promote agro-ecotourism.
7. Harvest and store seed for the community seedbank. Distribute surplus seed for diversity kits and research, and to interested farmers who have expressed interest in multiplying and sharing seed with at least five neighbours. In addition, maintain seed for a diversity block of each crop as a field genebank. The next year's block can be used for further demonstration and evaluation and will increase the quantity of 'basic' seeds for subsequent years. This exercise can be sustainable if the community recognizes its value and links the block with the community seedbank or community-based seed production activities.
 8. Update the database of the community biodiversity register to encourage participants to engage in on-farm conservation and landrace enhancement.

Tool 4: Community biodiversity registers

A community biodiversity register (CBR) refers to '*a record, kept in a register by community members, of the genetic resources in a community, including information on their custodians, passport data, agro-ecology, cultural and use values*'. CBR is basically a community effort to document and conserve the biodiversity used and its associated 'traditional' knowledge. In Nepal, the use of CBRs has been under development since 1998, with the aim of strengthening *in situ* on-farm conservation of crop diversity. Several institutions have started to promote CBRs for various purposes, and as a consequence, different methodologies for CBRs have evolved. These are of two distinct types: (i) an inventory of economically valuable biodiversity at the local level; and (ii) an account of local community capacity to document important genetic resources and traditional knowledge for conservation and development purposes. The CBR answers key basic questions like (a) What materials do we have? (b) How do we use them? (c) What do we value most? (d) Who are the custodians of knowledge and materials? (e) Why do we need to conserve them? The CBR methodology is best explained with reference to the following 11 steps:⁸¹

1. Share its rationale and purpose with the community and form a committee;
2. Organize a biodiversity fair for locating diversity hotspots and custodians;
3. Identify biodiversity-rich communities and their institutions;
4. Develop a working modality;
5. Provide training, orientation and exposure visits on the method to interested communities;
6. Prepare a minimum dataset for the register;
7. Start documenting traditional knowledge in an agreed format (register, video, tape, digital image) and validate information;

8. Build community capacity to analyse information and share key findings with the community;
9. Develop a code of conduct for access to materials and sharing the benefits arising from the commercial use of materials;
10. Support the committee in developing livelihood strategies and conservation actions based on information generated in the register;
11. Register and maintain economically and culturally valuable biodiversity at a village level office register in order to claim ownership.

The CBR method is still evolving and research teams are further developing it as an empowerment tool for managing biodiversity at the community level. However, the impact of the exercise in the project has been significant; during a national workshop on biodiversity registration, the Nepal Ministry of Forest and Soil Conservation, IUCN, the Ministry of Agriculture and Cooperatives and several NGOs asked the project staff to train their employees and seek technical inputs.

Tool 5: Community seedbanks

A community seedbank is a community-managed *ex situ* collection designed to enhance access to local varieties and associated knowledge for the benefit of the community. Local crop germplasm, information and associated knowledge are collected from within the community, markets and neighbouring villages. The germplasm is stored, regenerated or multiplied, and distributed to fulfil the seed requirements of farmers for their diverse agro-ecologies and to promote on-farm conservation. Community seedbanks are emerging as a reliable tool for supporting on-farm conservation in high-technological interventions and high input farming systems ('resource rich production environments'), as well as in communities within largely marginal ('resource-poor') environments. The community seedbank established in Kachorwa* (a 'resource-rich' rice production environment) in Nepal proved to be a sustainable contribution to enhancing local seed security, responding to local seed demands, enhancing farmers' access to quality seeds, and promoting on-farm conservation of local crop diversity.⁵⁷ Since the establishment of the community seedbank, the number of rice landraces has increased and local seed security in terms of availability and access has improved considerably. It is important to note that community seedbanks are not designed to supply communities with their total seed requirement. Their key objective is to ensure access to local crop diversity by serving as a source of varieties for multiplication. They still allow a decentralized crop and seed production, and selection and storage of farmer-saved seeds. Following encouraging results from community seedbanks in Nepal in the context of on-farm conservation, a partnership with plant breeding programmes and agriculture development agencies has been stimulated to promote the utilization of the local varieties maintained. The next step in community biodiversity management should be research and development efforts to ensure conservation and use, with the consequent income generation improving the farmers socio-economic position.

* See also Section 2.4 by Pitambar Shrestha and colleagues on community seedbanks in Nepal.

Tool 6: Diversity kits

The diversity kit is a set of small quantities of seeds of various varieties, and sometimes of various crops. The kit is made available to farmers for informal research and development. It consists of seeds harvested from diversity blocks, collected from community seedbanks, research farms, or farmers' fields. Community-based organizations regularly distribute kits to farmers. (The tool is similar to the informal research and development approach developed by Lumle Agricultural Research Centre,⁸² and later scaled up by the project of the Centre for Arid Zone Studies Natural Resources in South Asia,⁸³ as a component of a strategy for disseminating and testing pre-released varieties with a scheme for participatory varietal selection. The diversity kit differs from this approach, since it aims to deploy a diversity of cultivars and crop species with the objectives of promoting local innovation, augmenting community access to diversity and increasing resilience in the context of integrated pest and disease management.) Diversity kits require few resources, and have a big impact. They promote farmers' evaluation of materials, and farmer-to-farmer seed and knowledge dissemination. No rigid procedures for diversity kits exist, which makes the approach very user-friendly. The steps for applying the tool are as follows:

1. Conduct diversity fairs at a regular interval of 2-3 years;
2. Identify unique, rare and useful diversity using PRA or participatory four-cell analysis;
3. Grow local varieties in diversity blocks for characterization and seed multiplication;
4. Ensure quality of seed by testing germination, viability and health of freshly harvested seeds;
5. Store 5-10 kg of seed in the community seedbanks (optional) and prepare diversity kits from the rest of the seeds (ranging from 100 g to 2 kg depending upon the nature of the crops);
6. Identify local institutions for the distribution and monitoring of the spread at community level;
7. Distribute diversity kits of rare or unique landraces and notify passport data of the recipient farmers for future impact monitoring;

Diversity kits are more successful if attention is paid to the following: (i) identifying genetic resources for food and agriculture that are valued by resource-poor farmers; (ii) linking diversity kits with community seed production groups, community seedbanks and *ex situ* collections; (iii) linking diversity kits with farmers' field schools and participatory plant breeding programmes; and (iv) training farmers for selection and maintenance within grassroots or farmer breeding.

In Nepal, formal research organizations take a critical approach to the tool as they consider kits a potential source of new pests and diseases in farmers' fields. This concern should be taken into consideration because pests and diseases can easily spread along the crop diversity. However, such concerns should be addressed at the source itself by producing quality seed for the kits.

It is preferable to use locally available valuable seed and plant materials in diversity kits, as they will generate immediate income for the custodians and will help to other farmers to obtain new materials. The availability of genetic materials,

including products of landrace enhancement, pre-breeding and participatory plant breeding, are important for its success as they will motivate community participation. Most importantly, diversity kits improve access to germplasm and encourage farmers to search for to use for selection, exchange and maintenance of preferred seeds/plants; in fact the kit is inserted into and stimulates existing social seed networks. One of the essential steps is to monitor the rate of varietal spread among households within and between communities through diversity kits. Researchers and development workers will be able to learn about the factors affecting farmers' decisions about starting and continuing to cultivate the varieties disseminated. The tool has potential for scaling up in wider geographical, institutional and socio-cultural contexts. Many development and research institutions have the mandate to improve access to locally adapted materials that generate social, economic and environmental benefits.

Tools promoting use as a means of conservation

Experiences from Nepal and on-farm conservation projects in other countries demonstrate that the above mentioned community tools are effective for empowering communities in the conservation and use of crop genetic diversity. More importantly, as collective actions, they raise awareness of the value of local genetic diversity and strengthen the informal seed system with a focus on conservation and use. Over time, these community actions will build farmers' and their grassroots institutions' capacity and potential for plant breeding. Participatory breeding programmes that adopt the principles of empowerment, social inclusion and biodiversity enhancement are crucial for supporting farmers' livelihoods and the continuation of farming as a rural activity. The participatory tools described here enhance farmers' and grassroots institutions' capacities to assess existing diversity, select niche-specific locally adapted materials, multiply selected populations, and distribute diversity within and among communities through social networks. The set of tools constitutes a simple approach that maximizes use of the crop diversity upon which farmers depend for their livelihoods. The tools may well become a core strategy for responding rapidly to the new demands of farmers facing climate change. The aim of the tools is the one that is at the heart of this book: to enhance our understanding of seed systems and to support them.

3.8 On-farm conservation of farmer varieties: selected experiences in Asia

Arma Bertuso, Hans Smolders and Bert Visser

Genetic resources form an important component of food security. For thousands of years, farmers have been responsible for the conservation of these valuable resources through producing, harvesting, selecting, storing, improving and using the varieties that are adapted to their agro-ecological conditions and that meet their needs and preferences. However, the threat of genetic erosion to sustainable crop production

and also food security continues to haunt farmers and farming communities. Through the modernization of agriculture, many governments focus on a few crops and monocropping practices, coupled with the use of chemical fertilizers and pesticides. Moreover, globalizing food patterns create markets and socio-economic conditions with consumption patterns that favour the development of less diverse farming systems. Environmental factors such as the changes in climatic patterns (global warming) and habitat destruction cause loss of biodiversity. Last but not least, the centralization of breeding into a limited number of public institutions and multinational companies excludes farmers in their role as breeders.

Three conservation strategies for genetic resources may be distinguished that have developed to respond to these developments: *ex situ* conservation, *in situ* conservation and on-farm management. This third strategy of on-farm management advocates the maintenance of local crop varieties at the community level. It is not only restricted to saving and preserving varieties in farmers' fields and communities in a narrow sense. It depends on a dynamic system where crop varieties can continue to evolve in the place where they originated, and thus respond to changes in selection pressures, caused by pests, diseases, and even global climate change. This section focuses on this strategy, and shares two experiences: Participatory Enhancement of Diversity of Genetic Resources in Asia (PEDIGREA) and the Southeast Asia Regional Initiatives for Community Empowerment (SEARICE). Both are on-the-ground initiatives from NGOs and farmers' organizations. In the approach, the organizations involved in these activities integrate strategies for the conservation of genetic resources with strategies supporting the livelihood of the communities involved.

PEDIGREA: on-farm conservation through local village genebanks

PEDIGREA is a Southeast Asian initiative that was established in 2002. It aims to develop practical and sustainable approaches for on-farm management of crop genetic resources. It has two focal points: (i) to strengthen local communities' capabilities to enhance their crop and animal germplasm, and (ii) to create a market for their community products. PEDIGREA works on participatory improvement of rice, local vegetables and local farm animal breeds through the farmer field school approach. It has three sites: Indonesia (West Java), Philippines (Mindanao) and Cambodia (South-eastern part).

The projects sites are situated in rice-based farming systems with reduced crop genetic diversity resulting from the massive promotion of so-called high yielding varieties of the Green Revolution programmes. Rice is produced for home consumption and seasonally varying surpluses are sold in the market, while vegetables form a major source of income. The seed system is mixed. Most farmers produce their own rice seeds, while vegetable seeds are often purchased in local markets. This dependence on local markets often results in varying and unpredictable harvests. Often the seeds purchased in the market guarantee neither seed origin and quality, nor the adaptability of the variety to local growing conditions.

PEDIGREA's overall aim is to contribute to food security, including improvement of diets, and to promote the on-farm maintenance of genetic resources.

In its participatory plant breeding programme,⁸⁴ local seed storage of the varieties and their breeding lines is a crucial problem faced by the farmers. PEDIGREA was challenged to address this concern and assists farmers in developing their local seed storage through local village genebanks.

Village genebanks are generally established to conserve the local crop-specific diversity of varieties produced by farmers in a specific region. They contain varieties that are representative of the genetic diversity of the area, in order to ensure that the seed and varieties stored are used and frequently accessed by farmers, thus minimizing chances of genetic erosion. In PEDIGREA, the village genebanks are slightly different from conventional genebanks, since they store not only seeds of local varieties, but also breeding lines. First of all, since the farmers are involved in local breeding, they need to access the genebank more frequently to access germplasm. Hence, village genebanks need to be established in the vicinity of the farmers. Secondly, the amount of seed of breeding lines may be double or triple the amount of seed of the local varieties stocked. Lastly, breeding lines require more information concerning history and traits, needed in the monitoring of the breeding progress. This means the need for labelling and record keeping is higher than in a conventional genebank.

The village genebanks are small, easily accessible and low-tech. One genebank per village community is established after completion of the farmer field school. It continues its activities throughout the follow-up field studies and supports the work of the community or individual farmers in their breeding programme. This decentralized type of genebank has a specific cost advantage. It is relatively small and closely tied up with the users and may therefore be more sustainable in the long run. It is important that the genebank supports participatory plant breeding but also contributes to the conservation of local genetic diversity.

In the village genebanks, different storage methods are used, depending on the purpose and length of storage. In *inter-seasonal storage*, seeds are stored for up-to four months. Conditions of storage are not very sophisticated. In order to maintain viability, seed is stored in a rat-proof cupboard, on the shelf in a ventilated room, or in panicles hanging from a rope. Rat-proof aluminium cupboards are used in Cambodia to protect against rodents and adverse weather conditions. The cupboards are kept in a cool, dry room away from the sun. In *over-seasonal storage*, seeds are stored for four to 10 months. The purpose of this type of storage is to secure seed availability and viability over a longer span of time, generally a wet, dry or fallow season, unsuitable for planting. It can also be used as a backup facility in case the seeds are lost because of floods or drought. Backup seed may also be required for selection purposes, for example, in cross pollinating crops, when one season is used for line evaluation, and the next for planting the selected lines, thus avoiding undesired out-crossing (a recurrent selection method). Low-tech rat-proof storage like air-tight seed drums or glass bottles with added ash for desiccation, capable of storing seed at reduced moisture content, are well suited to this type of storage. In Indonesia farmers use tin containers (with a lid, locally available for dry biscuits), plastic bottles or larger containers with added ash to keep the seed dry, or neem leaves against insects. The third type is *long-term genebank storage*. Once collected and characterized, local varieties,

especially more exotic materials, are stored as a backup for future use in local breeding programmes. Small glass bottles are used in Indonesia for long-term seed storage of rice and vegetable varieties. The mini bottles which are locally purchased at pharmacies are sealed with a plastic lid and paraffin, and kept in a home-made polystyrene box in a refrigerator.

An important aspect of the local village genebank is record keeping and labelling to avoid mixtures and eventually variety loss. During the farmer field school and follow-up field studies, farmers record many characteristics concerning their local varieties and breeding lines. These characters include maturity, plant height, pest resistance and taste. At the end of each season, the information is collected for end-of season evaluation and then documented in a record book, usually by a farmer trainer. Varieties and breeding materials are marked with labels or by writing with a pen on the plastic bag or fruit. Although efforts are under way to streamline documentation practices, for the moment it appears that each community has its own way of recording the data. Some recording methods are simple, while others are more sophisticated.

The local village genebanks are crucial in the conservation of local varieties and create a basis for participatory breeding programmes carried out in the farming community. Proximity to the farmers is essential for conservation and participatory plant breeding efforts. The genebanks increase farmers' access to local varieties and breeding materials. A more secondary but also very important motivation for the establishment of a village genebanks is that they also increase farmers' and communities' pride and ownership over their genetic resources.

SEARICE: on-farm conservation to strengthen farmers' seed supply systems

SEARICE is a non-governmental organization working since 1989 on community-based conservation, development and management of plant genetic resources in Southeast Asia. SEARICE is actively involved in community-based interventions, including training, education, dissemination of information, technical consultancy and resource mobilization. Currently, SEARICE implements and coordinates the Biodiversity Use and Conservation in Asia Programme (BUCAP) and the Community Biodiversity Development and Conservation (CBDC) Programme in Lao PDR, Bhutan, Vietnam, Thailand and the Philippines. The genetic resources work of SEARICE started with an emphasis on on-farm conservation in a strict sense, but in the mid-1990s this shifted to include crop development perspectives. We will share here some experiences of SEARICE that link conservation strategies with participatory plant breeding initiatives.

A first example is *community seedbanking*,⁸⁵ which forms an integral component of the community-based genetic resources conservation and utilization project. Peoples' organizations are involved in setting up community seedbanks with the aim of ensuring the farmers and communities a steady supply of varieties. The community seedbanks are managed by farmer organizations. For seed storage, the farmers use recycled plastic water bottles and glass bottles. Bottles are sealed with candle wax at the opening to prevent changes in seed moisture content. The farmers are trained in seed processing to ensure that seeds are clean and properly dried prior to storage. It

has been difficult to sustain the continuity of the community seedbanks, particularly in relation to problems in maintaining the necessary seed viability. Management of the facility is also a problem, as the farmers can only maintain a limited number of varieties. Increasing the number of varieties would need additional resources from the already resource-poor farmers.

A second example of a SEARICE activity is *Center-based Seedbanking*,⁸⁶ which was started in 1992 after a collection expedition for rice and other cereals by the Community-based Native Seeds Research Center (CONSERVE) in five provinces in Mindanao, South Philippines. The CONSERVE project is one of the first projects on seed conservation that SEARICE implemented in the early 1990s. The collected varieties were characterized for documentation, and the materials were stored for the short and the medium term. For short-term storage, the accessions were stored in bottles with desiccators like charcoal; the seeds were kept as active collections and distributed to farmers. Similar accessions were also kept in a refrigerator for medium-term storage as backup. In December 1997, part of the CONSERVE collection was stored in the medium-term cold storage room at the Philippines Rice Research Institute (PhilRice) located at Muñoz, Nueva Ecija. Samples were stored for duplication and for long-term storage under a black box arrangement. The black box contains 541 varieties, representing 72.8% of the total number of the CONSERVE collection. The black box storage at PhilRice is covered by a memorandum of agreement between SEARICE and PhilRice. The project staff regularly monitors the viability of the accessions in the black box.

In another CBDC project of SEARICE's in Bohol, a seedbank was established in 2001 at the Central Visayas State College of Agriculture, Forestry and Technology (CVSCAFT). The seedbank is a short-term storage room that serves as a backup of the materials distributed to farmer-partners by SEARICE. The total germplasm holdings include more than two hundred varieties, composed of traditional or local varieties, farmer-bred varieties, farmer's selection varieties, NGO-bred varieties, formally released varieties, CVSCAFT-bred varieties and selections and exotic varieties from Thailand and Vietnam. Farmers are participating in 'center-based seedbanking', and have been trained in seed processing and storage. They are usually involved in the rejuvenation of the accessions.

Another strategy used by SEARICE is the *curatorship for on-farm conservation*, in which varieties are maintained in farmers' fields. Accessions are grown in the farmers' fields by farmers assigned as curators. The materials are for farmers' use and safe-keeping. In the CONSERVE project in Mindanao, upland and lowland farmers received around 10 varieties from the collections. The farmers continued to produce a small amount of seeds in their own fields so as to preserve the varieties. Planting these varieties in the farmers' fields was recognized as a more important form of conservation than storing their seeds in the seedbanks. The varieties were allowed to evolve and adapt to changing environments, making them more viable and stable. On-farm conservation helps farmers to innovate themselves in their own fields and on their own terms. The varieties thus remain under the farmers' control, and remain dynamic.

SEARICE uses these conservation strategies along with other initiatives on participatory plant breeding and participatory varietal selection in farmers' fields to strengthen the farmers' seed supply system.

Linking conservation and utilization: lessons from working in the field

Conserving farmers' varieties helps farmers to incorporate and use them in the local seed supply system. The seed supply system becomes more dynamic with farmer-to-farmer exchange. Diversity becomes easily accessible. With readily available materials, these activities in Asia have encouraged farmers to select and develop better suited varieties based on their needs and preferences, and on local agricultural conditions. In this way, farmers' rights to save, store, exchange and use plant genetic resources have been strengthened. It is important to emphasize that the various strategies contributing to on-farm conservation are closely linked with farmers' utilization of the crop varieties. Farmers conserve varieties that are useful to them, both for the present and the future. On-farm conservation of germplasm is fully dependent on farmers' use. At the same time, farmers' varieties are not static, but develop over time, and older farmers' varieties may be replaced by newer ones. This means that what is conserved on-farm is not a given set of varieties at any point in time, but a range of genetic diversity that is essential for farmers to continually develop new materials. This is why this dynamic system of genetic resources handling is better described by the terms *on-farm management* or *on-farm development*, than by *on-farm conservation*.

4 Participatory crop improvement and supporting informal seed supply

4.1 Participatory crop improvement and informal seed supply: general introduction⁸⁷

Walter S. de Boef and Juliana Bernardi Ogliari

Participatory techniques applied in plant breeding can have an impact on the development of improved crop varieties, making it faster and more cost-effective. Targeted beneficiaries of such breeding programmes may be resource poor farmer households in marginal environments who previously solely cultivated local varieties or landraces, or farmers in more productive environments where they were dependent on old improved varieties. This section gives the historical context of participatory approaches in crop improvement and delineates the differences between participatory varietal selection (PVS) and participatory plant breeding (PPB). It goes on to elaborate on the participatory tools involved in starting participatory crop improvement (PCI), and to provide an overview of the structure and components of PCI.

Participatory crop improvement in an historical context

PCI emerged as an alternative plant breeding approach for developing countries in response to the recognition that conventional breeding by formal sector institutions had brought little benefits to small-scale farmers in agro-ecologically and socio-economically marginal and variable environments.⁸⁸ Formal breeding in developing countries concentrated on cereals and cash crops in favourable, high-input agricultural systems. It was expected that at least some of the materials which were developed for high-input production systems would also be successful in low-input environments. However, apart from wheat, maize in parts of South East Asia, and Eastern and Southern Africa, and irrigated rice in South East Asia, these expected spill-over effects have been limited. Farming systems in marginal environments are too different from those in the more favourable production areas. Improved varieties that are currently being used by farmers in marginal areas are usually part of a portfolio of varieties. In most situations in developing countries, local varieties tend to remain the primary source of germplasm for a majority of small-scale farmers. In the case of minor crops, in which formal crop improvement organizations have invested limited resources, farmers usually rely entirely on local varieties.

Limitations of formal crop breeding

Formal breeding has tended to concentrate on increasing yield potential in favourable environments with access to agro-chemical inputs and irrigation, and to pay little or no attention to the importance of adaptation to variable and risky low-input rainfed conditions, secondary crop uses and cultural preferences. For example, when improved maize varieties that are bred at high plant densities are planted at low density in less favourable environments, they can show incomplete ear-cover by the husk, which makes them vulnerable to field and storage pests and diseases. Farmers' common use of variety mixtures and their preference for specific bean colours have also been important reasons for the limited impact of improved bean varieties in Africa and Central America, respectively.⁸⁹ While breeders concentrated on grain yield in barley, other locally important uses have been disregarded or overlooked; this is explained by the breeders' focus on breeding for high yields and wide adaptation, and their lack of knowledge about the importance of other characteristics for small-scale farmers.⁹⁰ In view of the relatively large area still planted with local varieties, it can be concluded that formal breeding in many countries and for many crops has failed to address the agro-ecological diversity of low-input farming systems in a satisfactory manner.

For cost benefit reasons, formal breeding attempts to develop varieties that are broadly adapted and can be released over large areas. The broad adaptation of such varieties often gives them yield stability over time and space. In developing countries, breeding programmes are largely carried out on-station under well-controlled conditions, thus reducing environmental variation and increasing heritability and expected genetic gain. However, most small-scale farmers operate in environments in which variable, complex stresses dominate crop performance. The common usage in formal breeding of relatively high input levels to minimize abiotic and biotic variation and to target moderate to high-input agriculture, not only reduces the ratio of environmental variance to genotypic variance in comparison with lower input levels, but also increases the discrepancy between on-station and on-farm conditions.⁹¹

The control of variation in the environment with the objective of creating uniform experimental areas is a positive aspect of formal breeding programmes; it allows for the identification of those superior genotypes by their genetic traits rather than by their phenotypic expression of the traits. When management practices creating uniform research conditions are also distinct from farmers' management practices, the material selected often appears inappropriate for cultivation in stress-prone environments. The genotype x environment (GxE) interaction causes these discrepancies. Therefore, products from breeding programmes are not necessarily adapted to the marginal environments dominant among small-scale farmers in developing countries,⁹² nor to, for example, low-input or organic growing conditions among organic farmers such as those in Europe.⁹³ If environments are sufficiently different, G×E interaction can result in different yield ranking of evaluated germplasm, representing the so-called cross-over effect.⁹² In such as case, on-station selection does not result in the most productive materials for the specific conditions in the farmers' fields.

In addition to differences in growing conditions, differences in selection criteria contribute to diversity in the materials selected by breeders and farmers. G×E interaction is normally determined for one characteristic, most often yield. The overall performance of a certain genotype is, however, determined by a complex of characteristics whose relative importance further determines the ultimate ranking. In formal breeding, the relative importance of the various characteristics can be described by means of a selection index. Rejection of varieties by farmers points to situations in which the selection index as used by the breeders does not correspond with the farmers' own weighting of preferences. This is explained by the fact that farmers tend to pay more attention than breeders to yield stability, and characteristics related to quality and secondary uses.⁹⁴ Because the criteria other than yield appear to be very important factors in variety adoption and rejection, it is logical to include them explicitly in the analysis of G×E interaction and related issues in the context of PCI.

Participatory crop improvement: strategy and definitions

PCI aims to link formal and informal seed systems through crop improvement, identifying complementary capacities and expertise, and seeking to combine the improvement of productivity with the supply of agrobiodiversity needed by farmers. A common strategy is to insert useful genetic diversity into the local systems and to build on farmers' capacity for seed selection. Rather than trying to increase the impact of conventional breeding that generates a limited number of genetically uniform varieties at the end of the breeding pipeline, the idea is to introduce larger amounts of materials into the farmers' fields, thereby providing access to a wider range of genetic diversity. PCI builds on the recognition of farmers' capacity to select what best fits their environment and on improved development of local crop adaptation through farmers' variety and seed selection.* It relies on farmers' seed production and exchange to maintain and diffuse varieties, thus creating a larger independence from the formal system of distribution of seeds of improved varieties.

The main advantage of PCI over conventional breeding is that it involves farmers in developing, adapting and adopting new varieties, in setting breeding goals, and in selecting parents according to their requirements. Levels of participation vary, however, with the nature and objectives of the projects and the availability of resources. Among some organizations and farmers, there develops a spirit of close collaboration and of appreciation for each other's capabilities and contributions. The strengths and capabilities of different stakeholders can then be fully utilized in an integrated form. This is why these processes are now gaining worldwide acceptance.

A common functional distinction within PCI is between participatory variety selection (PVS), and participatory plant breeding (PPB). PVS is the term used for selection from among advanced or genetically stable populations and lines in self-pollinated species, or among populations in open-pollinating species, while PPB denotes selection from within segregating populations,⁹⁵ with different degrees of inbreeding after the F₁ generation or within cross-pollinating populations based on

* Niels P. Louwaars and Conny Almekinders address the issue of farmers' selection and maintenance of varieties more in detail in Section 2.1.

selection of full-sib, half-sibs etc, according to the selection strategy. In PVS, farmers are given varieties (finished products from plant breeding) for testing in their own fields. After a successful PVS programme, the varieties preferred by farmers can be used as parent or composite populations in a breeding programme where farmers participate as active collaborators. This involves breeding and selection to create new varieties and is called PPB. However, the distinction between PVS and PPB is not always clear. Especially in the case of cross-pollinating populations, selection among populations (PVS) is usually combined with within-population selection (PPB). On-farm evaluation allows for weighting of preferences and needs by the end-user of the products, and enables exploitation of G×E interaction through seeking location-specific adaptation to the complex and variable environment.

Participatory varietal selection

PVS is defined in different ways for different crop reproductive systems. In self-pollinating crops, it is the selection of released or pre-released advanced lines. In open-pollinating species, it is the selection of cross-pollinating populations, and in vegetatively propagated crops, it is the selection of advanced clones. The selection is performed by farmers in their target environments using their own selection criteria. Landraces or local varieties are included in all types of trials. Basically, PVS provides varietal choices to the targeted farmers under their specific environmental conditions, promotes participatory approaches to variety testing, and selects and disseminates the preferred variety. Essentially, a PVS programme follows four logical steps, applying several participatory appraisal tools²³ and community practices as is illustrated in Table 4.1.*

PVS is about testing new varieties with farmers; this can be done in many ways. No set protocol exists: methods vary for different crops and for different researchers' and farmers' circumstances. Nonetheless, generalizations can be made concerning the resources required for different methods. PVS is widely used and accepted in breeding programmes. In the literature, PVS is more and more accepted as common practice in breeding. Gary Atlin, who was in charge of the IRRI upland rice breeding programme, stated that all breeding programmes should include participatory on-farm trials.

There are many ways of carrying out participatory trials. A common methodology is the mother and baby system, the design of which can vary considerably. CIMMYT and its partners in Southern Africa apply a three replication mother trial with 12 entries. The trial is repeated twice in two different management regimes (for example high and low fertility). The baby trial has four entries in an incomplete-block lattice design. However, the total of baby trials includes all the entries within the mother trial that year. WARDA and its partners in West Africa use a single replicate mother trial of about 60 entries in rice PVS, sometimes repeated twice in two management regimes (high input and farmer managed). The baby trials are planted in the next growing season, with the number of entries in line with the number of entries selected by researchers and farmers in the mother trial. In the work

* Bhuwon Sthapit and colleagues describe some practices supporting community biodiversity management and the relevance to participatory crop improvement in Section 3.7.

of the Centre of Arid Zone Studies (UK), public and non-governmental research and development organizations in India use single-replicate mother trials grown under a farmer-managed regime, and baby trials in which each farmer grows only one test entry alongside his or her local control. Thus, experimental designs vary according to the crop, the experience of researchers, technicians and farmers with PVS, and the degree of farmers' organization. The diversity of approaches shows that there are many forms of PVS that need to be adapted to the conditions and the resources available.

Table 4.1 Outline of steps of a PVS programme and the participatory appraisal tools and community practices applied⁹⁶

<i>Step</i>	<i>Participatory tools and community practices</i>
1. Situational analysis and needs assessment	<ul style="list-style-type: none"> • A participatory rural appraisal (understanding community and demands) • Documentation of local practices (maps, flow charts) • Documentation of local materials (matrixes, flow charts, four cell analysis)
2. Search for genetic materials	<ul style="list-style-type: none"> • Inventory of local and improved materials (crop diversity and variety maps and matrixes) • Inventory of pre-released material • Brainstorming for identification of characteristics and preferred varieties • Various ranking tools to identify characteristics and materials
3. On-farm experimentation	<ul style="list-style-type: none"> • Diversity blocks and diversity fairs • Cultivation of introduced materials aside with local materials under farmer management • Farm walks • Focus group discussions (selection criteria, meta plan, matrix ranking)
4. Wider dissemination	<ul style="list-style-type: none"> • Post-harvest evaluation • Community meetings • Dissemination through kits and fairs • Monitoring spread and diffusion

Participatory plant breeding

PPB is a breeding process in which farmers and plant breeders jointly select cultivars from segregating materials under a target environment. Other forms of PPB include activities such as germplasm enhancement through pure line or mass selection, stratified mass selection within composites, selection of half-sibs when breeding cross-pollinating crops, or the identification of mother trees or plants when breeding perennial or vegetatively propagated crops. Although many people claim to work with PPB, in fact most of them conduct PVS. PPB can either be consultative or collaborative. Table 4.2 illustrates the differences between these two typologies for farmer participation. A basic differentiation exists in the division of responsibilities in decision making on selection criteria and in selection itself.

Table 4.2 Typology of farmers' participation in PPB

<i>Consultative PPB</i>	<i>Collaborative PPB</i>
<ul style="list-style-type: none"> • Farmers are consulted to set breeding goals • Farmer choose appropriate parents and testing sites • Farmers indicate demands that are translated into selection criteria by breeders 	<ul style="list-style-type: none"> • Farmers set breeding goals • Farmer choose appropriate parents and testing sites • Farmers grow segregating genetic material • Farmers indicate selection criteria • Farmers contribute to the selection of best plants

The success of PPB rests on the blending of the comparative strengths of farmers, local extension agents, breeders and social scientists involved in the process. The use of consultative or collaborative methods and the right choice of the level of farmers' participation depend on: crops; the capacity of the participating farmers; the willingness and availability of breeders, extension agents and farmers; the degree of farmers' organization; and the research resources available. However, there is a commonly applied law in PCI that PPB only commences after several years of successful PVS implementation, as farmers first need to learn to work with genetic diversity and gain some experience in formal experimentation.⁹⁵

PPB becomes an option when efforts with PVS are reaching their limits because the possibilities of PVS have been exhausted, or the search process in PVS failed to identify any suitable cultivars for the testing. Another reason to move from PVS to PPB could be because farmers identified a new problem in existing cultivars that requires the recombination of local varieties with other germplasm. Then a PPB strategy becomes a demand-led approach.

Due to their access to the global pool of germplasm and the often genetic make-up of certain traits within that germplasm, breeders are better equipped to make an effective choice of parents. In the case of self-fertilizing crops, this means that at least one parent in the PPB programme should be a landrace or locally adapted cultivar. In the case of cross-pollinating crops, local varieties should contribute to the development of composite populations. Screening takes place in the target environment, utilizing farmers' selection criteria and knowledge.

In PPB, farmers are involved at much earlier stages of the breeding process. In the case of self-fertilizing crops such as wheat, rice or beans, this could be at the stage of F_3 or F_4 ,⁹⁵ while in cross-pollinating crops such as maize, farmers could, for example, be involved during various cycles of stratified mass selection within a composite variety, or recurrent selection of half-sib families of a composite population generated by farmers. In perennial crops or vegetatively propagated crops, few farmers could be involved in the identification and testing of, for example, super trees in the case of cocoa or coffee, or the selection within trials including large amounts of research materials in the case of potato.⁹⁴ When selection in PPB advances and the degree of genetic variation to be evaluated diminishes, PVS components follow. In the early stages of PPB, few knowledgeable or experienced PPB farmers join in, whereas more farmers and locations are involved in PVS.

Mother-baby trial designs can be used for generating scientific data using the mother trials for generating quantitative data and the baby trials for qualitative data. Baby trials can also be used for replication of quantitative data. The mother-baby trial format can be adapted to the crop, whether they are self-fertilizing crops (rice, teff, wheat or beans), cross-pollinating crops (maize), perennial crops (coffee or many fruit trees), or vegetatively propagated crops (banana, enset, sweet potato or cassava). As indicated, the mother-baby trials serve a dual purpose: the generation of research data, and the dissemination of PPB results or the primary dissemination of improved PPB materials. With this second purpose, PCI directly links the formal breeding system with both the indigenous knowledge system and the informal seed system for the evaluation and direct dissemination of material.

A wide range of diagnostic tools and community-oriented practices are used throughout the whole process of PCI. Table 4.3 provides a general outline of the steps involved in a PCI programme (not specified for crops with different reproduction systems). The table provides some options for the range of participatory diagnostic tools and community management practices applied during a PCI programme. The tools ensure community and farmers' participation and empowerment during the different steps, while the practices are ways to speed things up, particularly the initial process of identification of materials and farmer-partners. They also upscale the final part of the PCI programme (PVS), empowering farmers during the evaluation of promising materials and facilitating their large scale dissemination.

Roles of farmers and benefits

The benefits of farmer participation in plant breeding processes are not universal, and attempts have been made to create a balanced view of the need for such participation and the benefits it brings. Using the qualitative labels 'participatory' and 'conventional' for breeding programmes implies an 'either/or' approach to their definition, whereas what is needed is to build a bridge between the two camps by focusing on the degree of farmer or client orientation.^{97,98}

A key issue in the discussion around the potential of PPB and roles of farmers is the acceptable level of complexity of PPB programmes. The first PVS experiences indicate distinct roles for farmers and breeders. It is not clear yet how these roles change over time as PCI programmes develop and move from PVS to PPB. As indicated, over time, yield will become a more important component of PCI and will be subjected to the same consequences of G×E interaction as in formal plant breeding.⁹⁹ This may imply more complicated selection schemes for the farmers in order to ensure continued progress in performance. The farmers' willingness and capacity to invest time and resources in selection and participation with breeders will depend strongly on the benefits they derive from it. Benefits are: access to materials with increased yield, yield stability or other improvements, status, knowledge and increased capacities (empowerment), and benefits from seed exchange.⁸⁴ The latter benefit is based on the assumption that locally selected materials have a wide agro-ecological adaptation and are attractive to a larger group of farmers. Farmers' empowerment is considered an important social benefit from PCI. The type of participation presumably influences the empowerment impact on the farmers.

Table 4.3 Outline of steps of a PCI programme and participatory tools and community practices used⁹⁶

<i>Step</i>	<i>Participatory tools and community practices^{23,*}</i>
1. Need identification and setting breeding goals	
<ul style="list-style-type: none"> • Understanding the reasons for growing diverse varieties • Setting breeding goals and roles jointly to meet immediate needs 	<ul style="list-style-type: none"> • Participatory rural appraisal • Community meetings • Focus group discussions • Ranking exercises
2. Parent selection and generating new diversity	
<ul style="list-style-type: none"> • Identification and use of locally adapted varieties as parent materials 	<ul style="list-style-type: none"> • Participatory rural appraisal • Focus group discussions • Diversity blocks
3. Selection of research plots and expert farmer role identification	
<ul style="list-style-type: none"> • Identification and selection of innovative farmers with an interest in PPB • Decision making on selection criteria 	<ul style="list-style-type: none"> • Focus group discussions • Farmer network analysis • Transect walk • Diversity fairs
4. Early selection	
<ul style="list-style-type: none"> • Management of research activities under farmers' condition • Farmers assume a role of selection: <ul style="list-style-type: none"> • within segregating materials • within composites or for example of half sibs • among super trees • among clones within trials including large amounts of diversity 	<ul style="list-style-type: none"> • Researcher-designed, farmer-managed trials • Focus group discussions • Selection of materials jointly by farmer breeders • Preference ranking
5. Participatory varietal selection	
<ul style="list-style-type: none"> • Management of research activities under farmers' conditions • Mother baby trials in diverse formats • Distribution of promising material among large amounts of farmers 	<ul style="list-style-type: none"> • Focus group discussion • Ranking exercises • Diversity blocks • Diversity kits
6. Variety release and distribution	
<ul style="list-style-type: none"> • Varietal spread through informal seed supply • Release variety on the basis of mother baby trial results and monitor varietal spread 	<ul style="list-style-type: none"> • Mother baby trials • Diversity kits • Participatory rural appraisal monitoring variety performance

If farmers are only consulted and do not share in the process of decision making during the identification of parental material, the setting of selection criteria and the

* Bhuwon Sthapit and colleagues describe some practices relevant to participatory crop improvement in Section 3.7.

selection itself, there is neither true participation nor an empowerment benefit.⁸⁴ Empowerment or the capacity of farmers to work on improving their own situation is recognized as an important condition for sustainable agricultural development in less favourable marginal production environments,⁹⁹ organic or low-input conditions,⁹³ and even high input production systems.¹⁰⁰

PVS and supporting informal seed supply

During PVS, farmers, extensionists and breeders evaluate improved released, pre-released or local varieties on-station and/or on-farm. These components of breeding programmes have been shown to enhance farmers' access to varieties (improved or local) from other areas. The best and most suitable materials can be disseminated quickly through the informal seed system, although the organization of seed supply for variety maintenance and distribution beyond their breeding areas through PPB may require some help from the formal system.²⁷ Linking the participatory approach with informal distribution methods will enhance the availability of and access to seed of varieties that farmers want. It is clear, then, that participatory crop improvement and supporting informal seed supply are interdependent and complementary efforts.

4.2 Opportunities for participatory crop improvement and supporting informal seed supply in Oromia region, Ethiopia

Adugna Wakjira, Gemechu Keneni, Musa Jarso and Bulcha Weyessa

Participatory Crop Improvement (PCI)* can broadly be defined as approaches that involve close collaboration among breeders, researchers, farmers, and other stakeholders, to bring about plant genetic improvements within a given plant species. It covers the whole research and development cycle of activities associated with plant genetic improvement: identifying breeding objectives, generating genetic variability, selecting within variable populations to develop experimental materials, evaluating these materials, releasing promising materials, and producing seed, whether through formal or informal channels. The component relating to the evaluation of materials is also referred to as participatory varietal selection (PVS). PCI also includes assessing existing policy and/or legislative measures, and designing new ones where needed. In other words, farmers, breeders, and other relevant stakeholders such as traders, processors, and consumers can take on distinct roles at various points in the crop improvement cycle, and pool their knowledge and skills to bring about meaningful changes and impacts.

* Walter de Boef and Juliana Bernardi Ogliari provide detailed definitions and descriptions of approaches to participatory crop improvement in Section 4.1.

The idea of involving farmers in the development of plants and their varieties is not new in Ethiopia, where several crops (for example, teff, noug, enset, Oromo potato, anchote, etc.) have been domesticated and perpetuated along with their production techniques. Unfortunately, in plant breeding programs the indigenous knowledge of the farmers has not been fully appreciated and farmers' experiences have been ignored. In this paper, we assess the past and present PCI and informal seed production efforts in central Oromia region, Ethiopia to suggest applicable and useful strategies that can benefit target users in line with the current agricultural development direction of the country. To this end, experiences were gathered and synthesized, and relevant publications were consulted, including the proceedings of several workshops and conferences.*

Developmental phases in participatory crop improvement

The agricultural research system of Ethiopia in general and Oromia region in particular have passed through several developmental phases. Improved production techniques have been generated and adopted, and various participatory approaches have been used, based on the policies, institutional set-ups and global knowledge and experiences of the time. So far, the research and development approaches that have been used can be categorized into four phases, based on major institutional reforms and degrees of farmers' and other clients' participation:

- Conventional on-station research/ breeding scheme (1966-1974)
- Package testing and multi-disciplinary survey approach (1975-1983)
- Farming systems research/ breeding programme (1984-1998)
- Client-oriented or participatory research/ breeding programme (1999-2007)

The first phase coincides with the establishment of the former Institute of Agricultural Research (IAR) in 1966, which is now renamed the Ethiopian Institute of Agricultural Research (EIAR). During this phase, a top-down approach was dominant where almost all plant breeding activities were undertaken on-station with little involvement of the farmers via demonstrations and field days. During the second phase, on-station-developed packages of crop improvement techniques were tested on the farmers' fields to verify their compatibility and performance under farmers' conditions. This stage played a vital role in creating a better understanding of the complexities of the farming system, and better linkages among breeders, extension agents and farmers. The farming systems research approach, phase three, dominated the mid 1980s, and increased farmers' participation in problem analysis, on-farm variety testing and evaluation. This stage increased the role of farmers in the variety selection processes and changed the attitudes of many breeders and extension workers.

It was from this phase that we moved into the fourth, contemporary stage, which is known as client-oriented participatory on-farm variety evaluations. It was first implemented in Ethiopia through Dutch-funded projects on barley, vertisol and cool season food and forage legumes. This approach attempted to modify farmers'

*The reference list does not include all workshop and conference proceedings used for this section.

participation from the consultative to the collaborative mode,* involving the ultimate beneficiaries in the varietal development processes, from the initial planning stage to the evaluation stage. This does not mean that PCI has been put in place in the central highlands of Oromia region. Various social, institutional, financial, and infrastructural constraints pertain, which have limited the scope for working in this participatory manner.¹⁰¹ Despite these limitations, both current and stretching back over the past forty years, some encouraging changes have been achieved in terms of agricultural technology generation and varieties released (Table 4.4).¹⁰²

Table 4.4 Summary of crop varieties released by the Ethiopian Agricultural Research System, Ethiopia (1970-2005)¹⁰²

<i>Crop</i>	<i>1970-79</i>	<i>1980-89</i>	<i>1990-99</i>	<i>2000-05</i>	<i>Total</i>
Cereals	15	23	56	101	195
Pulses	11	21	30	42	94
Oilseeds	6	9	8	15	38
Vegetables & spices	-	4	15	41	58
Fruits & stimulants	-	12	5	9	26
Fibre crops	4	5	4	-	13
Forage crops	3	5	1	-	9
Total	39	69	119	208	435

Why the interest in participatory crop improvement and support to informal seed supply?

To ensure food security and sustainable economic development

Ethiopia's current human population of an estimated 77 million (35% in Oromia) is increasing at a rate of 2.62% and is expected to reach 84 million by 2010.⁵ The broad thrust of Ethiopia's strategy for sustainable development and poverty reduction (Plan for Accelerated and Sustainable Development to End Poverty [PASDEP, 2005/06-2009/10])⁵ consists of an overriding focus on agriculture, especially on production and productivity of crops, as the sector is the source of livelihood for 85% of the population. Agriculture is also believed to be a potential source for generating primary surplus to fuel the growth of other sectors of the economy (industry and services).

The main components of the PASDEP economic development plan place a great emphasis on crop production. Table 4.5 presents the estimates of cultivable land, total production and productivity that are envisaged through area expansion and intensification (integrated use of agricultural inputs and better management practices). All these measures will be effective if implemented jointly with farmers and other stakeholders. And this is where there are significant roles for PPB and informal seed multiplication in putting the envisaged plans into action and ensuring food security and sustainable economic development.

* See Table 4.2 in Section 4.1 by Walter de Boef and Juliana Bernardi Ogliari for an explanation of the different typologies for farmer participation.

Table 4.5 Projected area, production and productivity of major crops in Ethiopia over five years (2004/05-2009/10)⁵

<i>Crops</i>	<i>Area (x1000 ha)</i>		<i>Production (MT)</i>		<i>Productivity (t/ha)</i>	
	<i>2004/05</i>	<i>2009/10</i>	<i>2004/05</i>	<i>2009/10</i>	<i>2004/05</i>	<i>2009/10</i>
Cereals	9053	9250	12.99	32.25	1.44	3.23
Pulses	1615	1689	1.56	2.13	0.97	1.26
Oilseeds	1223	1244	0.51	0.98	0.42	0.79
Fruits & vegetables*	367	419	1.55	2.72	4.22	6.51
Cotton	23	43	0.05	0.13	2.11	2.93
Total	12281	12649	16.66	38.21	-	-

Note: * under irrigated condition

To adapt plant varieties to their specific environments

The basic problem in plant breeding is the relationship between selection and target environment. Direct selection, i.e. selection in the target environment, is always the most efficient. But in indirect selection, i.e. selection in an environment different from the target environment, the selection efficiency decreases, with genotype x environment interaction (GxE) limiting the efficiency of breeding programmes.¹⁰³ Plant breeders can either avoid GxE by selecting materials that are broadly adapted to a range of target environments, or exploit them by selecting a range of materials, each adapted to a specific target environment.¹⁰⁴

The participation of farmers in the very early stages of selection offers a solution to the problem of adapting the crop to a multitude of both target environments and users' preferences.¹⁰⁵ Although decentralized selection and farmers' participation are unrelated concepts, the acceptance of the former as a breeding strategy almost inevitably leads to the acceptance of the latter as a tactical necessity. It is worth mentioning that, although farmer participation is often advocated for reasons of equity, there are sound scientific and practical reasons for farmer involvement too, as it can increase the efficiency and the effectiveness of the breeding programme.¹⁰⁴ Decentralized participatory plant breeding could be particularly effective in those situations where seed is supplied by the informal seed system, as is the case for several crops in the marginal environment of central Oromia (i.e. degraded, very cold and rugged mountains).

To promote effective adoption and to address specific needs of clients

Although PCI programmes are relatively recent, they have had some impact.^{104,105} In environments where no improved varieties were available, farmers have selected varieties according to their own preferences. A linseed variety combining frost tolerance with higher yield and good stand has been much favoured by the farmers in the mountains of Jeldu district, central Oromia, and the variety verification is under way for its specific release in 2007/08. Faba bean varieties combining disease resistance with desirable traits like large seed sizes were also much preferred in central Oromia (Welmera, Ejere and Degem districts) even before they were formally released. Other good examples in Ethiopia include varieties of field pea, chickpea,

potato, barley, maize, and onion selected by farmers. Through farmers' participation, desirable varieties have been identified at earlier stages than is usual in the conventional breeding system. Understanding the crop production problems and research priorities of local farmers in various agro-ecological and socio-economic conditions is a prerequisite for the selection of varieties for long-term adoption by the farmers. PVS has been successful in facilitating adoption by poor farmers in marginal environments who were not previously reached by formal plant breeding.^{104,105}

Information on farmers' selection criteria is one of the most common outputs of participatory crop improvement programmes.¹⁰⁴ Farmers are interested in a wider range of traits or combinations of traits than breeders expected. Although farmers nearly always rank yield as their most important criterion, they select for several other traits as well. In many cases, farmers' selection criteria vary according to the physical and socio-economic environment. For example, in Eastern Ethiopia, farmers' selection criteria for common beans varied with each growing zone and season, giving high priority to growth habit, reaction to diseases, suitability for intercropping and seed yield, out of about twenty criteria.¹⁰⁶ Similarly, farmers' selection criteria for teff varieties have given top priority to white seed colour (for marketability), seed yield and panicle length.¹⁰⁷ Women farmers in west Shewa Zone selected field pea varieties for the qualities required for *kik* (split pea) and *shiro* (crushed pea), whereas the male farmers emphasized yield and yield attributes, showing that selection criteria may differ between the genders.

To ensure sustainable seed supply

For many centuries, Ethiopian farmers have been relying on their own seeds, selecting appropriate grains, storing them, and then using them as seed for the following season. They have been doing this with a great diversity of crops, including vegetatively reproduced crops. By choosing seeds or planting materials that meet their needs, they have developed local varieties that suit their specific farming circumstances and preferences. As a result, hundreds of local varieties of several indigenous Ethiopian crops (teff, Niger seed, sorghum, barley, durum wheat, field pea, etc.) have developed. According to some estimates, up to 95% of the farmers in Ethiopia still produce and use their own seeds and thereby depend on their skills acquired through generations.¹⁰³ Hence, building on local resources, knowledge and abilities will maintain and increase the continued supply of seeds for the small-scale farmers. Technical support for the informal seed supply from researchers, development agents and NGOs is crucial in this regard.

In order to ensure the continued supply of improved seeds of several crops, the Ethiopian government has launched a plan for producing improved seeds on farmers' plots during a five-year development period (PASDEP, 2005/06-2009/10).⁵ Accordingly, the Ethiopian Seeds Enterprise (ESE) will ensure the continued supply of improved seeds, with a focus on pre-basic and basic seed multiplication activities. The emphasis is on promoting seed multiplication activities on farmers' plots (farmer-based seed production). Moreover, the private sector is encouraged to participate in the multiplication of improved seeds. By the end of the plan period, a total of about 0.18 million tons of seeds of improved varieties is expected from these sources. Of

this, 90 thousand tons will be produced on farmers' plots, while 72 thousand tons will be supplied by the ESE. The remaining 18 thousand tons is expected to be produced by private seed producing organizations.

To enhance biodiversity

Genetic diversity at farm level plays an important role in ensuring household food security for smallholders in Ethiopia. Diversity of crops and varieties serves diverse household needs for consumption and other uses. Farmers also need crop genetic diversity to cope with such variable environmental conditions as outbreaks of new crop pests and diseases, changing climatic conditions, soil erosion, changing market conditions and increasing population pressure.

One of the most common outcomes of participatory crop improvement is that farmers select different varieties of crops for different purposes. Examples are available for a range of Ethiopian crops, including barley, haricot bean, faba bean, and linseed. This practice gives rise to substantial increases in the numbers of available cultivars and populations.¹⁰¹ Hence, farmers' local crop improvement or PCI is required to continue evolving valuable germplasm for future breeding and specific uses. In short, genetic diversity has been and will continue to be valuable in both modern and traditional agriculture, both for increasing productivity and for ensuring sustainability, and determining future progress.

Recent efforts to promote participatory crop improvement and support informal seed supply

Since the mid 1990s, the national research system, international donors and NGOs have provided strong support to participatory research and development efforts in central Oromia region, Ethiopia. Typical examples include training programmes delivered by the International Centre for Development Oriented Research in Agriculture (ICRA, Wageningen) and the research support of the Royal Netherlands Government for Barley, Vertisol and Cool Season Food & Forage Legumes projects. The CGIAR centres, like CIMMYT, ICARDA, CIAT, IFAD and ICRISAT have also contributed a lot to the Ethiopian research and development programmes. Projects like the African Highland Initiatives (AHI) and Soil and Water Management Network (SWMnet) of the Association for Strengthening Agricultural Research in Eastern and Central Africa (ASARECA) have played significant roles in supporting PCI and informal seed production. As a result, there has been significant progress with this approach and with informal seed production of potato, lentil, haricot bean and wheat crops.

Breeder and pre-basic seed that was produced at Holleta Agricultural Research Centre has been supplied to the ESE, farmers, NGOs and other users together with trainings and similar technical back-up. For instance, 2,309 tons of potato seed tubers were produced in three districts from 1999 to 2005 and 116 tons of chickpea and lentil seeds were produced in west Shewa zone of central Oromia in 2006/07. Similar efforts are currently underway with other field crops (cereals, pulses and oilseeds) in various districts of central Oromia, with the full assistance of the research institute. Another important step being taken is the ongoing decentralization of PCI activities

from the main research centre to sub-centres, research sites and farms. In fact, many farmers in several districts in the central highlands of Oromia are currently involved in the informal multiplication of seeds for improved varieties of crops like wheat, barley, chickpea, lentil, potato and linseed. Research and development agents now need to capitalize on these efforts for positive impacts.

The main success factors for these recent developments include the positive attitudes and commitment of the stakeholders (researchers, farmers, development workers, NGOs, etc.) towards PCI and supporting informal seed supply. Increasingly, resources and inputs (funds, vehicles, breeder/pre-basic seeds, and fertilizer) become available for supporting such efforts. Technical support (training, skill/experience sharing, and follow up) is becoming more effective. Materials released meet specific needs (environment, preference, quality, etc.) better, and market opportunities for informal seeds are increasing.

Major challenges faced in further promoting these approaches include how to work with farmers' socio-economic realities, i.e. dwindling farm sizes, free grazing, poverty, high illiteracy, poor infrastructure and farm tools. Another challenge is how to guarantee institutional support, i.e. incentives, strong direction and influences. Currently researchers and extensionists involved in these approaches face lack of funds, vehicles and skilled technicians; so a re-allocation of resources supporting the approaches is required. Variety release and seed policies still pose significant constraints for the further institutionalization of PCI and promotion of support to informal seed supply. Supportive policies and guidelines are needed.* A further challenge is how to channel quantities of germplasm and segregating populations/lines into different areas and design ways of formal and informal multiplication of the products of PCI.

Reflections on the future

Recent experiences with PCI and supporting informal seed supply, and the on-going up scaling of technologies in central Oromia region, Ethiopia clearly demonstrate the effectiveness and efficiency of both approaches for enhancing the availability of improved seeds and farmers' access to them. These approaches have the potential to foster the economic development of the country and to contribute to attaining the goals of the Plan for Accelerated and Sustainable Development to End Poverty. The decentralized national system of agricultural research has created a situation conducive to supporting the development of both approaches in accordance with the specific physical environments and socio-economic circumstances of farmers. Opportunities must be seized to develop and release specifically adapted varieties, and to convince policy-makers re-adjusting variety release requirements and seed production policies to promote and encourage PCI and support the informal seed system. Conducive environments and technical support from the formal sectors could also encourage the establishments of community-based and small-scale seed enterprises. Both intra and

* In Section 7.5, Walter de Boef and Anthony van Gastel share the recommendations as formulated by a significant group of policy makers during the policy workshop of the Tailor Made Training Programme on Informal Seed Supply in Ethiopia.

inter diversity of crops (useful landraces, improved varieties, well-adapted populations) need to be enhanced and utilized to meet the current and future needs in a sustainable manner.

4.3 Participatory varietal evaluation and breeding of the common bean in the Southern region of Ethiopia

Asrat Asfaw

The Ethiopian common bean breeding programme has developed many productive varieties with the potential to increase yield per unit area. However, there has been very limited uptake of improved bean varieties by smallholder farmers in the South Nations, Nationalities and Peoples' Regional (SNNPR) state. This limited adoption can be partly attributed to the restricted effectiveness of the breeding programme addressing the farmers' biophysical production environments. In conventional bean breeding, selection and testing environments are often fertilized, well weeded, flat, fertile and uniform land, and trials are grown in sole crop stands. This is in contrast to farmers' bean production environments: These landscapes are usually unfertilized (depending on the wealth of the farmer), sloping, less fertile and heterogeneous. They vary between and within farms and villages, and crops are mostly grown in inter or relay cropping systems. Breeders' selection or testing environments do not reflect the full range of farmers' myriad production environments. A second reason for low adoption is the limited effectiveness in addressing users' and clients' needs, i.e. limited involvement of the farmers and other actors in variety development. As a result, most of the bean varieties released through conventional breeding programmes have less acceptable characteristics such as none-attractive seed colour, seed size, cooking time and taste. They are often not diverse enough to meet the preferences of local bean farmers and consumers.

The conventional bean breeding approach lacks contextual thinking in addressing the issues of for whom and in what context the new genetic technology (variety) will work. Matching selection and testing environments with target farmers' production environments (i.e., by decentralization of selection and testing environments) and having farmers and other end users participate in the breeding process would apparently enhance the efficiency and effectiveness of bean breeding.^{97,108} Having farmers participate in the breeding process helps to fit the crop to the specific needs and uses of farmers' communities¹⁰⁹ and improves cultivar adoption.¹¹⁰ Participatory variety evaluation (PVS) and participatory plant breeding (PPB) are techniques for integrating clients' or end-users' needs and including actual production environments in the crop improvement process. This section outlines the process and lessons of integration of participatory techniques in bean breeding in the southern region of Ethiopia.

Local bean production and seed system in context

The crop, *Phaseolus vulgaris* L., was domesticated in Andean South and Middle America about 7000 to 8000 years ago and probably introduced to Africa in the past four centuries.¹¹¹ It is thought to have been introduced into Ethiopia by the Portuguese in the 16th century. Since then, farmers have developed bean cultivation practices adapted to the local conditions by maintaining the bean's adaptive and productive potential, and the present genetic diversity of beans in farmers' fields is the result of continued human-plant-environment interaction, i.e. the preservation and exploitation of useful alleles. The crop is not traditional in Ethiopia and hence does not show high genetic diversity in comparison with other 'centres of diversity' like Central America or the Andean region, or even with other African countries like the Great Lakes region. However, the population genetic structure of Southern Ethiopian farmers' bean varieties is not well known despite the believed narrow genetic base.

Beans are grown under diverse farming systems and agro-climatic conditions; either as a mono-crop or inter-cropped with maize, sorghum, coffee, etc. Farmers cultivate beans twice a year: first during the short '*Belg*' rainy season from February to April and then in the long '*Meber*' rainy season that starts in June and usually ends in September. In the *Belg* season, beans are usually intercropped with maize, sorghum and coffee while in the *Meber*, they are often planted as sole crops or relay cropped with maize or sorghum. The *Belg* planting takes the lion share of bean production of the region.

SNNPR is one of the major bean production belts of Ethiopia. The crop is principally cultivated for home consumption by smallholder farmers but in recent years it has been rapidly evolving into a cash crop. Both the small seeded Mesoamerican and the large-seeded Andean bean type are grown and consumed, although the preference for each type differs across regions. Small white beans of the Mesoamerican gene pool are the principal export class for Ethiopia. Smallholder farmers predominantly grow the small whites in the central rift valley. Small red-seeded beans are the most popular bean class in southern Ethiopia, although the preference in some areas is for Andeans. In the drier areas like Konso and Derashe, black beans are predominant. In Gedio coffee-based agro-forestry system, farmers grow climbers. In different production niches, farmers grow different bean seed classes. Adaptation to local climatic and agronomic conditions as well as the post harvest domestic sphere and market preference (local and/or export) might dictate the dominance of certain ideotypes in certain localities.

Farmers obtain bean seeds for planting from different sources. About 1.5% of bean farmers in SNNPR used improved seeds in the 2003/04 *Meber* season planting,¹¹² presumably obtained or purchased from formal seed sector institutions. The remaining farmers planted seed they obtained from other informal sources. The Ethiopian Seed Enterprise is the only formal seed sector institution that produces certified bean seed. Under the current commercialization of bean production, research institutes, universities, NGOs, farmer cooperative unions and offices of the Bureaus for Agriculture and Rural Development are engaged in bean seed production and supply to farmers. The seeds from these sources are usually some form of quality declared or truthfully labelled seeds. The supply from formal seed sources has never

met the farmers' actual seed needs. However, it is not clear how the different bean seed supply and demand mechanisms interact in the region. In general, both formal and informal seed systems are operating for bean production in the region, although their degree of dominance differs greatly.

Design of participatory research in bean breeding

Participatory techniques were used at different stages of bean breeding. Farmers were involved in selection of fixed as well as segregating populations.

Selection of fixed variations

The research design made use of participatory on-station selection and follow up of on-farm selection, and performance evaluation and diffusion of selected materials. Three participatory approaches were used: (i) decentralized participatory individual selection, (ii) decentralized participatory group selection and (iii) participatory group evaluation by neighbouring non-selector farmers. The selection process was conducted from 1999 to 2003 at two sites, Remeda and Korangoge, in Sidama zone of the SNNPR.

In decentralized participatory individual selection, farmers were invited to evaluate a wide range of germplasm (147 diverse fixed lines including 8 climbers, 36 large-seeded and 103 small- to medium-seeded beans). The collection was planted on-station and managed by a breeder at Remeda during the 1999 *Belg* season. Forty-four individual farmer-selectors (10 women and 34 men) participated in the selection process. Individual farmers selected lines they considered interesting, based on their own criteria without any outsider interference. Subsequently, individual farmer-selectors planted their selections in their own field ("individual plot trial") according to their individual preferences, and attempted selection for three consecutive *Meber* seasons (1999, 2001 and 2002).

In decentralized participatory group selection, all farmer-selectors (participants in decentralized individual selection) from the two sites were invited to visually assess and select all individual farmer selections pooled and each planted at "communal plot trials" at respective sites in 2001 and 2002. For attempting group selection, the participating individual farmer-selectors from the two sites were further divided into sub-groups: a group of all women selectors, one of all men selectors, and a non-gender desegregate group from the two sites. The groups were asked to select materials from amongst those selected at their respective individual selection that they thought would be useful to them as a group and to other farmers in the community. The communal plot trials were researchers managed at Remeda and farmers managed at Korangoge.

In decentralized participatory group evaluation, the participants were 10 neighbouring non-selector farmers (5 men and 5 women) representing the bean farming communities from the two sites. Evaluators were farmers who made the final assessment of selected lines but did not directly participate in the previous selection. The farmer-evaluators rated the individual farmers' selections planted at respective years and sites on a 1 to 5 'appreciation scale' (1 = worst and 5 = best) for selection traits (agronomic and market). The selection traits were further elicited using open-

ended and verification interviews and through informal interaction with each selector and evaluator farmer.

Selection in segregating variations

Based on the participatory varietal evaluation exercise, attempts were made to cross the farmers' preferred lines to generate more preferred variability for further participatory selection. A breeder produced 26 single-cross populations and advanced them to F₄ populations using the single pod descent method. The 26 F₄ populations were planted at Kokate in the 2004 *Belg* season for single plant selection by farmers. Four farmers attempted single plant selection. The farmers' single plant selections were planted in progeny rows at Amaro in the 2004 main season to screen the lines for low soil moisture stress. The promising lines at Amaro were advanced to F₆ at Awassa in 2005 main season for breeders' evaluation. The promising F₇ lines selected were planted at Kokate in the 2006 *Belg* season for farmer evaluation. Twenty farmers (including those who attempted single plant selection) participated in evaluating the lines. The participatory approach used was decentralized group on-station selection and evaluation.

Both the selections and the evaluations were conducted when the crop was close to physiological maturity and after threshing. The grains of each line from the previous year's harvest were presented in transparent plastic bags at the time of selection and evaluation at physiological maturity, so as to give the farmers options for selection and evaluation for seed characteristics. Farmers used their own judgment, based on their own selection criteria, to retain or reject the materials without any interference from the researchers.

Results of the participatory breeding programme

Farmer selection of fixed variations

The number of lines selected by a farmer ranged from five to 51 and on average, a farmer selected 15 lines in the first selection cycle in the *Belg* season of 1999. During the final selection cycle in 2002, the number of lines selected by a farmer ranged from one to four and on average, a farmer retained two preferred lines for production. At the final selection, the participating farmers at the two sites retained in total 17 large-seeded and 17 small- to medium-seeded beans i.e., 34 lines out of the diversity of 147 lines they were exposed to in 1999. Exposing farmers to diversity elicited farmers' implicit demands for bean varieties which were not made explicit during participatory rural appraisals and group discussions. Farmers need diversity for quite different purposes: varieties producing well under no or low fertilizer input conditions, varieties responsive to fertilizer application, beans preferred in local markets, beans mainly for home consumption (women), beans for home consumption and local markets, beans suitable for sole cropping, and beans suitable for intercropping. Farmers participating in the breeding process created access for the communities to improved bean germplasm (new genes) and increased intra-varietal diversity at farm level at the sites where there was a low level of bean diversity before.

Farmers applied diverse selection criteria to maintaining bean varieties on their own field. The diversity in selection criteria is an indication of the complexity of users' needs and production conditions. The more diverse the selection criteria, the better the chance of maintaining large diversity on-farm since all positive traits are seldom available in a single variety. However, the selection process and subsequent interviews with farmers revealed that seed colour and seed yield were decisive criteria in retaining or rejecting a variety. Yet, other characteristics are considered descriptors for the selection of a good line: e.g. large seed size, tall plant height, early maturity, high pod load, long pod, high number of seeds per pod (> 5 seeds/pod), strong stem (non-lodging), upright growth habit, pod clearance from the ground, good taste and fast cooking. Red and red mottled are the preferred seed colours.

During group selection, farmer-selectors identified bean lines preferable in their community by majority votes. However, low consistency in selection was observed among groups over years and locations. In all the selection events, greater proportions of larger seeded bean lines were retained as compared to the small and medium seed sized lines. A similar selection preference was observed during individual selection.

Table 4.6 Mean grain yield and farmer preference of bean lines evaluated at communal and individual plot trials in 2001 and 2002 at two locations

<i>Variety</i>	<i>Mean grain yield (kg/ha)*</i>		<i>Mean preference rating#</i>
	<i>Communal plot trial</i>	<i>Individual plot trial</i>	
CAL-170	999.4	727.7	3.9
AFR-697	948.9	1086.3	2.9
OBA-4	1112.6	1340.8	3.2
AFR-708	1069.7	809.4	3.1
DICTA-109	1565.6	1529.8	2.6
Roba-1	1414.9	1143.9	3.6
RAB-585	1200.9	1245.1	3.8
AFR-702	1323.7	1659.5	3.5
Red wolayta (local variety)	1117.2	838.6	2.9

Notes: * Average of two years and two locations;

Preference rating where a variety rated 5 is the most preferred and 1 the least preferred.

Of the new farmers' selections which were evaluated in diverse management conditions in 2001 and 2002, *DICTA-109* in the communal plot trial and *AFR-702* in the individual plot trial recorded the highest yields of 1565.6 and 1659.5 kg/ha respectively (Table 4.6). The results revealed that some of the highly preferred varieties like *CAL-170*, with a mean preference rating of 3.9 in participatory group evaluation, gave lower yields than the high yielding variety *DICTA-109*, rated with a mean preference of 2.6. This indicated that, for adoption of a new bean variety, it is not only grain yield but also farmers' qualitative criteria and assessments that are vital. The overall selection and evaluation process with farmers in participatory methods revealed that farmers are capable of selecting and evaluating varieties that give superior yields in their own field. This result is in line with Ceccarelli and colleagues¹⁰⁹ who stated that farmers can handle selection choices from among a large number of

lines, and that it is possible to transfer the responsibility for selection to farmers in their field.

Farmers' selection in segregating variations

The farmers who developed fixed lines performed remarkably. The participating farmers selected 26 populations from 500 single plants. Out of the 500 single plant selections by farmers evaluated at Amaro in the 2004 *Meber* season, the top ten gave on average a 19% and 55% yield advantage over standard and local checks, respectively (data not shown). The best 76 lines were then advanced to a preliminary yield trial at Awassa in 2005 for breeder evaluation. The promising 74 lines were then planted at Kokate along with four checks in the 2006 short *Belg* season for farmer evaluation and selection. The farmers attempted group selection and retained the best-preferred 11 lines for further evaluation. The grain yield of the farmer single plant selection in 2006 ranged from 1859.4 kg/ha (*ETAW-02-2-7*) to 6537.5 kg/ha (*ETAW-02-4-9*). Thirty five lines performed better than the best check (*DOR-554*).

Impact of participation on diversity and plant breeding efficiency

Exposing farmers to bean diversity, with fixed as well as segregating materials, resulted in the identification of new variation and the re-introduction of lost diversity attractive to farmers. The new as well as the re-introduced bean varieties provided farmers with more reliable seed yields under marginal environments. The newly selected lines offered yield advantages over existing farmers' varieties. Because of these and other good seed characteristics, they are highly appreciated by other farmers and consumers. Farmers' cultivation of new bean types and the subsequent supply to local markets created new demand niches for red kidney, red speckled and large seeded beans. Especially the red kidney varieties sell extremely fast in the local markets, and farmers complain that they cannot get seed. The creation of new niche markets for new beans in the region is an encouraging factor for the communities who developed the varieties. Because of good prices in the local market, some farmers started multiplying the new beans in larger areas. The introduced red mottled varieties create a new market for export to northern Kenya.

The integration of participatory techniques in common bean breeding resulted in increased farmer-held diversity. Farmers' skills in breeding were enhanced. Their selection criteria and preferences were adopted in the breeding programme and positive interactions between farmers and researchers increased the efficiency of the breeding programme. Consequently, participatory approaches also reduced research costs in relation to impact gained. Research was enabled to effectively target user needs, acceptable varieties were identified faster, and there were fewer research dead ends.

4.4 Participatory varietal selection of barley in the highlands of Tigray in Northern Ethiopia

Fetien Abay and Asmund Bjørnstad

Barley (*Hordeum vulgare* L.) is a major crop in the Tigray region of Northern Ethiopia, and its importance has been increasing as more areas have become drought prone over the past years. On average, barley covers 34%, 23% and 12% of cultivated land in eastern, southern and central zones within the Tigray region.¹¹³ Its production is rain dependent and its productivity is low. Increasing the productivity is therefore a priority for improving the food security of the poor farmers. Development of varieties for drought-prone areas has had less priority in Ethiopia; instead breeders targeted early maturing varieties. The national barley breeding programme initiated utilisation of local varieties since 1990 and some hulled barley varieties were released for large-scale production. During the past three decades 32 barley varieties have been released; six of these varieties have been widely distributed because the Ethiopian Seed Enterprise (ESE) produces their seed. Inadequate adoption and dissemination of the released varieties is also the result of limited seed production by the formal seed sector, local unavailability of seeds, and farmers' lack of awareness about improved varieties. The main reason for low adoption is the fact that the needs of low input barley growing areas of northern Ethiopia have not been adequately addressed in breeding, and the released varieties show a high degree of genotype x environment interaction in the farmers' fields.

In striving to transform its economy, Ethiopia is pursuing agricultural development-led industrialization for poverty reduction and food sufficiency. To achieve this objective, seed is considered an important component of the high input extension package. The participatory, demonstration, extension and training approach of extension agents emphasizes high input extension packages and provides seed of improved varieties and fertilizer on credit. The officially recommended improved varieties, i.e. *HB-42* and *Shege*, have not been adopted by farmers, however. Farmers in northern Ethiopia rely on their own knowledge and selection strategies in variety choice. To develop high yielding varieties specifically adapted to the variable rainfed environments found in Tigray, researchers and farmers have to join forces in experimentation and innovation. The potential of such participatory crop improvement (PCI) programmes for identifying preferred varieties, improving adoption of varieties, and enhancing productivity level, has been well documented.* This section describes the result of a participatory varietal selection (PVS) trial in Tigray, using the 'mother and baby' design, a systematic approach to participatory evaluation.¹¹⁴ The research was a joint effort by farmers, development agents, university students and researchers.

* Walter de Boef and Juliana Bernardi Oglari provide a more detailed description of definitions and approaches to participatory crop improvement in Section 4.1.

Steps in barley varietal selection

Diversity fairs

At the planning stage, village-level diversity fairs were organized. Each farmer was asked to display the varieties of barley that he or she was growing. The fair allowed farmers and researchers to exchange knowledge and identify constraints on adoption and dissemination of varieties. Knowledge exchange was important for identifying the relevant characteristics of farmers' varieties, selecting experimental varieties that will meet farmers' requirements, and learning about farmers' reasons for rejecting the released barley varieties. During the fair, farmers indicated their intention to include rare and endangered varieties in future testing. This led to a modification of the experimental design that the researchers initially proposed; both farmers' and researchers' suggested varieties were now included.

Identification of varieties to be included in the trials

Suitable varieties for the trials were identified, based on farmers' criteria; other varieties were deliberately included because of their limited adoption. The trials included four released or modern varieties, two farmers' developed varieties and three rare and endangered farmers' varieties (Table 4.7). *Dimtu* and *Misrach* are respectively released by Holleta and Debrebrhan research stations for both early and late sowings and high-and low-external input conditions. *HB-42* and *Shege* are released by Holleta for high input areas, but deliberately included because of their official recommendation for cultivation in Tigray. '*Himblil*' and '*Dembay*' are farmer developed, locally preferred varieties.

Table 4.7 Characteristics of the test varieties used in the experiment

<i>Variety</i>	<i>Source and method of Improvement</i>	<i>Row Type</i>	<i>Caryopsis type</i>	<i>Year of release/status</i>
<i>HB-42</i>	Exotic x indigenous cross IAR/H/81/compound 29// compound 1420/coast	Six	Covered	1984
<i>Shege</i>	Pure line selection from accession 1622-05	Six	Covered	1996
<i>Misrach</i>	Pure-line selection from <i>Kulmsa 1/88</i>	Six	Covered	1998
<i>Dimtu</i>	Pure-line selection from accession 3369-19	Irregular	Covered	2001
<i>Himblil</i>	Farmers' developed variety through pure line selection	Six	Covered	Preferred locally since 2000
<i>Dembay</i>	Farmers' developed variety through pure line selection	Six	Naked	Preferred locally since 2000
<i>Rie</i>	Farmers' variety	Six	Covered	Rare variety
<i>Sibumay</i>	Farmers' variety	Six	Covered	Rare variety
<i>Atona</i>	Farmers' variety	Irregular	Covered	Rare variety

Note: all varieties are of the late maturity type.

Identification of trial sites

Seven major barley growing highland districts in Tigray were identified jointly by the researcher and the agronomy section of the Regional Bureau of Agriculture. Highland districts with ≥ 2400 masl were deliberately selected because of the late maturing nature of the test varieties. On the basis of these criteria, seven districts were selected; two from central Tigray, i.e. Dogua Tembien (location Melfa) and Tahtay Maychew district (location Adinefas); two from eastern Tigray, i.e. Atsbi (locations Habes FTC and Habes on-farm) and Gantafesham district (locations Buket and Mugulat); and three from southern Tigray, i.e. Enderta (location Mekele), Endamekhoni (locations Bolenta, Mekhan and Neksege) and Olfa district (locations Menkere and Fala); see Figure 4.1. Holleta and Debreberhan (Mush) were included since the modern varieties, *HB42*, *Shege* and *Dimtu* were released from Holleta and *Misrach* from Debreberhan. At the selected sites, barley is grown in both the main and the short (*Belg*) seasons. The short season rainfall starts in January and extends to the end of April while the main season rainfall is from early June to the end of September. Off-season cultivation on the residual moisture (September to December) is also practised.

Figure 4.1 Map of Tigray and location of test sites



Identification of farmer experimenters

During village meetings, experimenting farmers were identified on the basis of their interest and the constraints that needed to be addressed. Known seed selectors were deliberately included. Farmers helped in the identification of interested farmers. In Tigray nearly 30% of the households are female headed. These households were encouraged to participate in the experimentation process; on average 20% (range of 8.3% - 25%) of the experimenter farmers were women. During the planning and implementation process, lack of oxen and ploughing skills of female-headed

households were raised as major constraints for participation. This expected challenge was managed through flexible solutions raised by farmers, such as sharing of labour with ploughing skills, and using neighbours and relatives' skills.

Experimentation: mother and baby trials

The PVS used a “mother and baby trials” system.¹¹⁴ Farmers’ knowledge and preferences were considered in decisions made on the varieties to be tested. At each site, farmers participated in providing farmers’ developed varieties and farmers’ endangered varieties. Farmers define ‘endangered’ varieties as those grown either in mixed cultures or by only a few households in neighbouring villages. Farmers helped in the identification of experimental fields.

See in Figure 4.2 an outline of the experimental design. A total of 21 mother trials were conducted: nine at the FTCs, three on the research stations (Mekelle, Holleta and Debrebrhan) and nine in farmers’ fields. The FTC and on-farm trials were conducted for two years (2004-05 and 2005-06) but the on-station trials were conducted for one year only (2005-06). Farmers’ fields served as replications in the on-farm trials. They were conducted in a randomized complete design with two replications at the FTCs and research stations. A plot size of 3 m² (1.2 x 2.5 m) was used for all trials.

Figure 4.2 Experimental design of the mother and baby trials

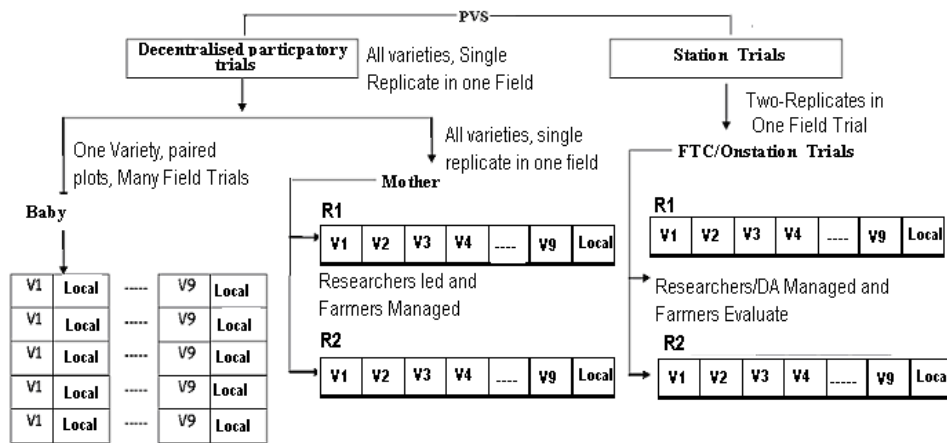

Baby trials consisted of paired plots of each test variety with a local check. One kg of seed of each test variety was randomly given to five farmers to grow it alongside their local variety on their farms under their own management conditions. A total of 180 farmers were involved in the baby trials; 45 farmers in each village. The objective of these trials was to test varieties under various environmental conditions and farmer management practices.

Cross visits within villages were organized for participatory evaluation at three stages of crop growth, i.e. at the vegetative, flowering and grain filling stage. During the flowering stage, evaluating farmers were asked to bring representative spikes of

five test and local varieties. Specific traits like spike length and number of grains per spike were recorded. Exposure visits across districts were performed to share the experiences of recognized seed selectors, mainly from Bolenta and Habes, and from Mugulat and Buket.

Data collection and analysis

The quantitative data from the trials were recorded by research assistants, development agents, and students of Mekelle University through the practical attachment programme, and supervised by the researcher from the University. Each farmer experimenter was given a logbook to record observations and quantitative traits such as days to heading, maturity, and plant height. Schoolchildren in the household were briefed so they could assist in recording of data. Three members from the village experimenters were elected to facilitate field monitoring and to provide the researchers with feedback.

For the harvest, the central four rows (2 m²) were hand harvested and hand threshed. In this way the grain yield (in grams and later converted into kg/ha) could be recorded. Household preferences were assessed on the basis of variety matrix ranking. The reasons for preference of a given variety were recorded and considered as criteria for ranking. The criteria and varieties were listed in a matrix to understand the choices between the varieties and traits and the constraints.¹¹⁵

Analysis of variance, using Proc GLM of SAS version 9.1, was computed for grain yield of year/location combinations (environments) and two year-location combination trials. The qualitative data collected from household questionnaires were subjected to Chi-square tests¹¹⁶ where the numbers of farmers responding better and not better in relation to the local variety were arranged in a two-way table.

Results from the mother and baby trials

The results from the mother baby trials are shown in Table 4.8. The coefficient of variation (CV) ranged from 6 to 16%, indicating the consistency of the experiments over the two years and locations. The overall mean yield of two years' trials indicated highly significant differences among the genotypes. The farmer-developed variety *Himblil* was the best: it was significantly different from other varieties, not only at the high yielding environments of Bolenta and Habes, but also at the driest site, i.e. Neksege, and in the waterlogged soils of Menkere. *Misrach* was superior to the two row local checks of Buket, Habes and Mugulat, but not at Neksege. It did not differ significantly from the six row local checks at Bolenta and Mekan and it was inferior to the local check at Menkere. In the relatively fertile soils of Bolenta and under waterlogged locations at Menkere, the yield advantage of *Himblil* over *Misrach* was 370, and 378 kg/ha, respectively. The superior performance of *Himblil* in waterlogged soils indicates a potential and genotypic variability for waterlogging tolerance, which is being further investigated. Its waterlogging tolerance was also observed in other trials. Except at Mugulat, where *Dimtu* was the best performing variety, *Dimtu* was either inferior or not different from the local varieties tested at different locations. The recommended varieties, *HB-42* and *Shege*, were consistently the lowest yielding varieties at all sites (Table 4.8).

Table 4.8 Mean grain yield of barley varieties grown at seven locations over 2004-05 and 2005-06

Variety	Mean grain yield in location (kg/ha)							Mean yield (kg/ha)
	Bolenta	Habes	Mugulat	Buket	Menkere	Mekhan	Neksese	
<i>HB-42</i>	455 ^g	105 ^f	156 ^f	203 ^e	219 ^h	297 ^g	100 ^h	219 ^f
<i>Shege</i>	819 ^f	706 ^d	800 ^d	558 ^d	820 ^d	681 ^f	483 ^f	695 ^h
<i>Misrach</i>	1250 ^c	1042 ^b	1056 ^b	1182 ^a	861 ^c	916 ^b	948 ^b	1036 ^b
<i>Dimtu</i>	1149 ^d	939 ^e	1330 ^a	917 ^b	728 ^f	828 ^c	764 ^c	950 ^d
<i>Himblil</i>	1620 ^a	1283 ^a	1089 ^b	1161 ^a	1239 ^a	952 ^a	1010 ^a	1193 ^a
<i>Dembay</i>	1195 ^{cd}	880 ^d	782 ^d	778 ^c	738 ^f	781 ^d	656 ^d	815 ^e
<i>Rie</i>	1180 ^{cd}	889 ^e	726 ^d	725 ^c	852 ^e	789 ^d	282 ^g	778 ^f
<i>Sibumay</i>	1413 ^b	875 ^d	612 ^e	523 ^d	490 ^g	658 ^f	386 ^g	708 ^h
<i>Atona</i>	960 ^e	648 ^e	782 ^d	723 ^c	787 ^e	732 ^e	522 ^e	729 ^g
<i>Local</i>	1262 ^c	970 ^e	950 ^e	951 ^b	958 ^b	933 ^{ab}	900 ^b	989 ^e
Location								
mean	1130	834	828	772	769	757	605	811
s.e.d.	78	57	44	63	31	30	19	16
CV	10	14	11	16	8	8	6	11

Note: Genotypes with different letters are significantly different; those with the same letters are not significantly different from each other.

Farmer's preferences and perceptions

A chi-square test analysis was performed for the matrix ranking of all experimental entries including local varieties.¹¹⁶ The overall farmers' preferences across the seven sites are presented in Figure 4.3. *HB-42* was rejected by 98% of experimenter farmers. *Dimtu* was preferred by farmers in Mugulat because they observed its 'stay green' trait during late season drought. However, it was not preferred at Bolenta because of its less compact, thin spike. The released varieties *Rie* and *Sibumay* were not preferred since their extended vegetative period made them prone to drought at the end of the season. The preference for high grain yield was only significant for *Himblil*. Overall, the preference was only significant for *Himblil* and *Misrach*, the latter not for yield but for its overall performance, indicating the multiple criteria and flexibility of farmers in maintaining varieties. The experiments also allowed information exchange among farmers and increased the familiarity with new varieties of barley. As shown in Figure 4.4, the area expansion of varieties indicates the acceptance by farmers, with a clear variation between villages for area allocation of each variety. At Bolenta, *Himblil*, *Misrach* and rare farmers' varieties are the most preferred ones. The latter were preferred because of their high yield in a relatively long growing season. *Dimtu* was favoured at Mugulat and *Misrach* at Buket. *HB-42* was not preferred and not planted in the second year, except at Buket and Mugulat by one and two farmers, respectively (Figure 4.4). In other words, the PVS already showed tangible results in its second year.

Figure 4.3 Overall preference ranking of barley varieties in three districts of Tigray

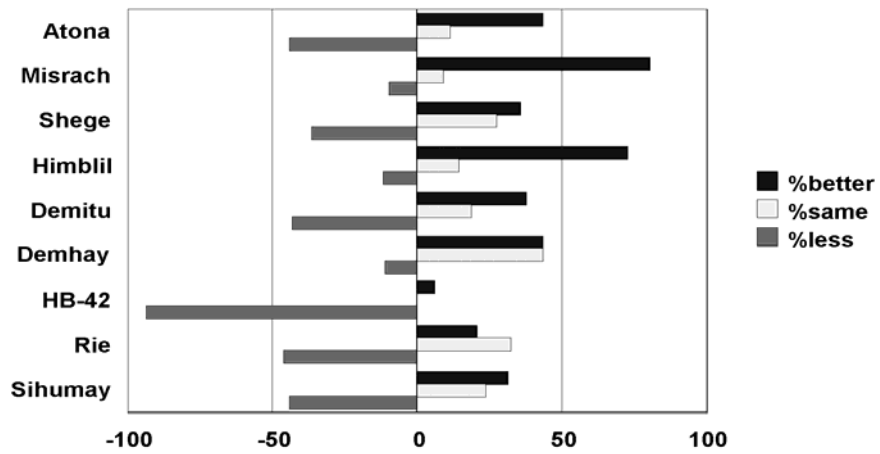
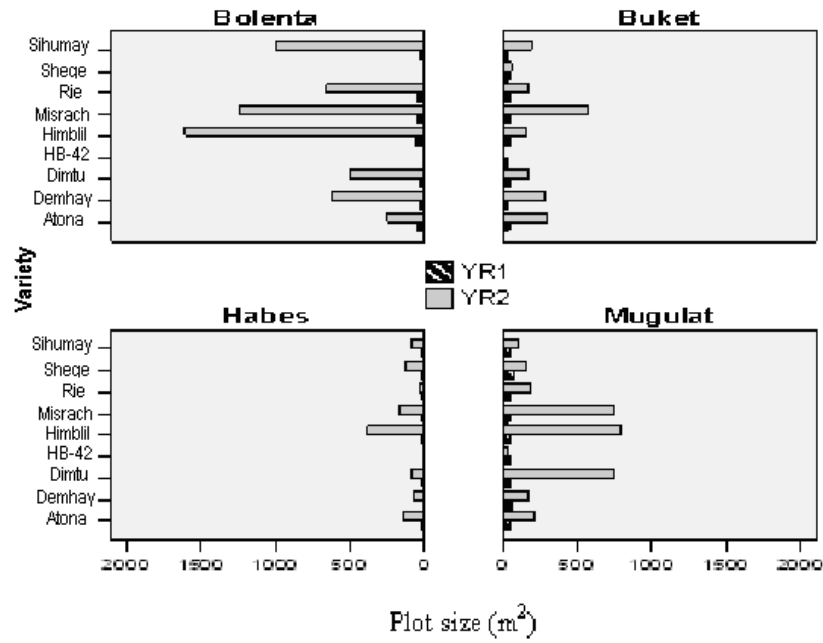

Figure 4.4 Area expansion in two years of preferred varieties by location



Lessons learnt from PVS in barley breeding in Tigray region

The merits of PVS for barley improvement in Tigray

The experiments have shown that PVS is a viable method for identifying preferences, constraints and the potential of varieties. The results of the PRA methods corresponded well with the data from the mother and baby trials, and the analysis showed that the level of accuracy was acceptable. The preliminary experiences of variety dissemination are also promising. For further work, strong collaborative networks have been established between the farming communities and regional extension workers. A group of farmers experimenting with introduced and local varieties spontaneously organized themselves in an “Association for Barley”, established to share information, ideas and seeds which they found to be more productive than other introduced and local varieties. This study confirms the practical use of a methodology for breeders and agricultural experts to perform varietal selection. The combined efforts of farmers, breeders and development agents may lead to more preferred varieties being tested, to the benefit of the farmers.

Choice of breeding strategies and genetic diversity

The results of varietal testing on-farm, at FTCs and on-station showed the importance of conducting selection in the target environment. The correlations between variety performance under stress and under favourable growing conditions were poor, indicating high genotype x environment interactions. This is similar to the data of Ceccarelli,^{117,118} who observed that the largest gains for barley improvement for drought stress can be expected from direct selection under stress conditions. In our studies, we found that the farmer-developed variety *Himblil* out-yielded recommended varieties. This confirms the relevance of targeting specific adaptation and the use of local varieties in breeding for stress-prone environments.

The expected yield advantages of the modern varieties *Misrach* and *Dimtu* were not realized. Only when grown under high input conditions did the two varieties perform better than the local varieties. The performance of the local varieties was much better than the performance of *Shege* and *HB-42*, the other two modern varieties tested. *Misrach* originates from a local variety in Arsi and has been promoted in Debrebrhan because of its superior waterlogging tolerance. However, *Himblil*, selected by a farmer in Bolenta, performed similar to or better than *Misrach*.

Local varieties are an important source of drought resistance.¹¹⁹ *Himblil* can be considered as a good source of abiotic stress tolerance, both to drought and waterlogging stresses. It is more stable than the improved varieties under the low input and low rainfall conditions of Tigray. The superior performance of *Himblil* in contrasting seasons and low input conditions confirms the importance of specific adaptation, as negative results were obtained when the variety was tested under high input conditions.

In current barley breeding in Ethiopia, increasing use is being made of more adapted germplasm and more relevant testing methods.¹²⁰ The performance of this new germplasm in the highlands of Tigray region approximates that of *Himblil*. If a

wider genetic diversity is used in crop improvement programmes, including local germplasm from Tigray region, even better cultivars may be developed in the future.

Variety recommendation

When looking at the various testing environments, the differences between high and low input conditions were more important than the differences between farmers' fields. The differential response of varieties to the environment indicated the relevance of conducting variety selection in the target environment. It can be concluded that there are good reasons for farmers not to adopt the recommended varieties *HB-42* and *Shege* which were released long time ago. The recommendation of inappropriate improved varieties makes farmers lose confidence in future released varieties. It is therefore important that EIAR and TARI revise their approach for variety testing and recommendation. Farmer-developed varieties should also be formally recognized and promoted in the target environment.* *Himblil* can be a potential candidate for formal release. The results of our studies indicate that it is possible to improve grain yields of crops in low input abiotic-stressed target environments.

Key conclusions from the study are that the improved varieties are not better than the local varieties, that joint evaluation of varieties helps in rapid dissemination of varieties and information, and that farmers are reliable partners in research and plant breeding.

* In Section 7.5 Walter de Boef and Anthony van Gastel share the recommendations as formulated by a significant group of policy makers during the policy workshop of the Tailor Made Training Programme on Informal Seed Supply in Ethiopia.

4.5 Working with farmer research committees in participatory bean breeding in Honduras^{*,†}

*Sally Humphries, Omar Gallardo, José Jiménez, Fredy Sierra
and the Association of CIALS of Yorito, Victoria and Sulaco*

Introduction: setting the scene

Origin of the initiative

The participatory bean breeding initiative in Yorito, Honduras, grew out of collaboration between la Fundación para la Investigación Participativa con Agricultores de Honduras, or FIPAH, a Honduran non-governmental research and development organization, local agricultural research committees known by the Spanish acronym, CIALs, and plant breeders at the Pan-American Agricultural School (Escuela Agrícola Panamericana, EAP), referred to here as EAP-Zamorano. The CIAL programme in Honduras developed from a pilot project set up by the International Centre for Tropical Agriculture (CIAT) in 1993. Following training by CIAT in participatory research methods in 1996, FIPAH agronomists facilitated the establishment of CIALs in three locations in Honduras, including one in the department of Yoro. Today there are 24 CIALs for adults and nine CIALs for youth located in the municipalities of Yorito, Sulaco and Victoria in Yoro.

From the outset, the CIALs searched for crop management alternatives that would improve on their existing practices. This involved simple split plot trials in which new varieties or techniques were evaluated against current practice. EAP-Zamorano provided the new germplasm for these trials. After more than three years of experiments conducted by the CIALs at multiple locations, it became clear to FIPAH and CIAL members that communities at higher elevations were not seeing many benefits from the newer technologies. In most cases, their own local landraces outperformed breeders' materials. This gave rise to the recognition of the potential for improving local bean germplasm through participatory plant breeding (PPB).

Problem addressed and local conditions

Beans in Honduras, as elsewhere in Central America, provide the poorest people with most of the protein in their diets. Farmers' bean varieties are mainly small in size and

* This section is adapted from a chapter with the same title by these authors in Almekinders, C. and J. Hardon (Eds). *Bringing farmers back into breeding. Experiences with participatory plant breeding and challenges for institutionalization. Agromisa Special 5*. Wageningen, Agromisa: pp. 47-57.

† The Honduras project is part of the Meso American Programme on Participatory Plant Breeding (Programa FP-MA, Fitomejoramiento Participativo Meso Americano): <http://www.programa-fpma.org/> FIPAH has been funded since October 2000 by USC-Canada, an NGO supported by the Government of Canada through the Canadian International Development Agency (CIDA).

red in colour. Black beans are also consumed in smaller amounts in rural communities but they have little commercial value. Breeders' varieties have tended to be darker in colour than farmers' red varieties and have frequently been rejected by farmers because of the low prices that they receive for these on the market. This, combined with the unreliable and frequently inferior yields of improved materials, particularly at higher altitudes, meant that poorer farmers, living in remote upland locations, had little interest in adopting newer varieties.

In spite of the disincentives for poor farmers to adopt breeder varieties, farmers readily admit that their own varieties are far from ideal. Through a visioning exercise, focus groups of Yorito farmers (17 women and 20 men) at higher altitudes came up with a wish list of traits for their ideal bean, presented in Table 4.9. Early maturity is an additional appreciated characteristic because it allows for food and income to be generated earlier in the season, which is particularly important in Yorito where the hungry period is lengthy and pronounced. However, there is a trade-off here against yield, and overall yield was considered by farmers to be the more important characteristic.

Table 4.9 List of ideal bean traits for Yorito farmers at higher altitudes in Honduras

<i>Agronomic characteristics</i>	<i>Pod and bean characteristics</i>	<i>Taste and cooking qualities</i>
<ul style="list-style-type: none"> • (Non-trailing) bush beans, 35-40 cm in height • Yields of 25-40 pods/plant • Disease resistant • Even ripening • Thick stem • Resistant to heavy rain and drought 	<ul style="list-style-type: none"> • Thickish pod to prevent the beans from sprouting during wet weather • 7-8 beans/pod • Longish, thick, heavy bean • Dark reddish colour, shiny • Easy to shell • Firm bean skin to prevent pest infestation in storage 	<ul style="list-style-type: none"> • Produces a thick soup when cooked and doesn't need lard • Expands in the pot • Soft, good tasting bean • Cooks quickly without much fuel

Note: the list of traits was developed during a visioning exercise by a focus group of 17 women and 20 men.

Local crop production and the seed system

The Honduran Government is responsible for seed regulation. In the past, it also played a key role in research but cutbacks in the early 1990s saw much of the research function passing to EAP-Zamorano, which conducts seed research both publicly and privately. Since the inception of the CIAL project in Honduras, FIPAH and the CIALs have been partners with Zamorano, testing out new germplasm as members of a network conducting regional adaptive trials. This has permitted EAP-Zamorano to acquire feedback on its materials from much less favourable resource areas than was previously possible.

As in many other parts of Honduras, Yorito has a six-month dry season from approximately November through to May. Farmers plant beans twice annually: once in May/June, when the rainy season begins, for harvest in July/August and again in October, near the end of the rainy season, for harvest in December. Beans are

produced both for consumption and for sale. Maize is generally sown once per year: planted in June and harvested in September or October. Most hillside farmers only produce maize for consumption purposes; on the whole, they do not own enough land to grow it commercially. Seed, traditionally selected by women at home, is mainly saved from one cycle to the next. Other crops include coffee, grown at higher elevations, and small quantities of vegetables and fruits for home consumption. Soybean has recently been introduced through the CIALs.

Like other poor farmers in the region, CIAL members report that climatic conditions have become more extreme over the past decade. Drought and torrential rains appear to be more common than anyone can remember in the past. Given the marked effect that the hungry season (*los juniros*) has on people's lives, any perturbation in weather patterns that delays the start of the rainy season or lowers grain yield during the growing season is a cause of major concern to local people: hunger is never far away. The decline in coffee prices in the early years of this decade added to this concern and contributed to increased out-migration.

Women's responsibilities in Honduras typically include managing small livestock, chickens and pigs, close to home. Responsibility for maize and beans, often grown on hillsides far from the house or village, is generally left to men. When women do participate in agricultural tasks away from the house, it is limited to certain activities, such as the coffee harvest or pulling up beans. Usually their involvement in these activities is a sign of poverty, as local mores dictate that women's rightful place is in the home.

The inclusion of many women within the CIALs has bucked this trend. In Yorito, women make up around 40% of all CIAL members. This can partly be explained by poverty, but also partly by the indigenous backgrounds of many of the women. In addition, the facilitation skills of FIPAH staff and farmer facilitators, who have provided a welcoming environment for women, have contributed to this.

Organizational and institutional structures

The Yorito CIALs are the largest organization of CIALs in Honduras: there are 105 men and 102 women members in 24 local (adult) CIALs. Nationally there are 80 CIALs with a total of 710 members. Information exchange between CIALs is common and farmers meet annually or biannually to present research findings to one another in national meetings. Thus the results of PPB are readily disseminated through the country's CIAL network to hundreds of other farmers who are equipped to test out new materials against their own local varieties.

In Yorito, four CIALs carried out PPB in beans on behalf of other high altitude communities in the area. The socio-economic characteristics of CIAL members vary somewhat between communities. In Mina Honda and La Patastera, they are extremely poor, as are most people in these two upland communities, and many are indigenous Tolupan. While most families have access to a small amount of land (less than 1.5 ha), this is generally of very poor quality. In the other two communities, there is more variation amongst CIAL members: a couple of the members own approximately 3.5 has. In Santa Cruz, two CIAL members are also farmer facilitators working with FIPAH and have considerable knowledge of experimentation, and are acknowledged

leaders in the regional Association of CIALs. The inclusion of three farmer facilitators in two of the CIALs conducting PPB undoubtedly helped accelerate the generation of knowledge by PPB. As a participatory research methodology, PPB is congruous with the CIAL methodology. CIAL members are familiar with conducting controlled experiments and are generally regarded by others in their communities as leaders in innovation and research.

PPB methodology and farmer participatory (breeding) practices

The research project presented in this section aimed to compare the results of three processes: (i) PPB with farmers (on-farm), (ii) conventional plant breeding (on-station) and (iii) distributing all materials generated on-station to farmers for selection in the 6th generation through single seed descent.

Genetic material used and locations for conducting trials

At the outset of the project, EAP-Zamorano provided segregating materials from F₄ generations to participating CIALs to accustom members to the challenge of working with unstable materials. Most previous CIAL experiments had involved PVS with F₆- and more advanced materials. Farmers had to learn how to manage such instability. Meanwhile the breeder crossed the most frequently utilized farmers' bean variety, *Concha Rosada*, with various breeders' materials. A population of 120 F₃ families, in which *Concha Rosada* was the maternal parent, was sent to CIAL members in Yorito for the early planting in 2000.

The original plan was to keep all the materials together in one 'collective selection site' in the community of Mina Honda until the F₆ generation with the four different CIALs conducting field and post harvest evaluations with the F₃-F₆ materials at this site. Land was provided by a community member in exchange for maize provided by the CIAL. However, almost immediately the CIALs voted to decentralize the trials and the selections that they made in the F₃-trials were taken back to their own communities at the end of that cycle. They felt this would permit greater genetic adaptation of the materials to emerge at an earlier stage in response to local environmental variations. The communities were located at a range of altitudes from 1550 metres above sea level (La Patastera) to 1260 metres (Santa Cruz), with Mina Honda (1350 metres) and Chaguitio (1460 metres) at intermediate altitudes.

Evaluation

Prior to the field evaluations, a workshop was organized in Mina Honda for participants from the four communities. The workshop explained to participants the background of the project, its objectives, and why they had been invited to attend. After the workshop, participants carried out an evaluation involving the identification of disease and other characteristics in the PPB (F₃) beans. The groups were broken down along gender lines to gauge differences in selection criteria between men and women. Each individual participant toured the experimental plot, seeking out materials that met his/her expectations. Individual selections were marked by coloured tags and the information was subsequently collated by the secretary of each CIAL. A trained team member noted down the criteria utilized by each participant in

selecting or rejecting materials. In this way, a picture was obtained of the most widely used selection criteria within the communities, broken down along gender lines. This process involved the use of open questions allowing interviewers to get a clear picture of the guiding selection criteria employed by participants.

Workshops on criteria of post-harvest selection and grain quality were carried out by FIPAH with the members of each CIAL team. Seed from each of the materials selected in the field was taken to each participating community. In each community, a table and benches were set up on which to display the materials. The seed from each plant family was then placed on a plastic plate with a label displaying its code or name. Five men and five women from the team or from the community were invited to observe the materials and comment on them. The other evaluators were kept at a distance so that they remained unaware of each other's choices. The preferred materials were marked and recorded by the secretary of each CIAL. The evaluators were also interviewed to find out the criteria for their decisions to select or reject a given material. The information gathered from these questions was then displayed on a flip chart to derive a scoring for each family. At the end, this information was analysed and consolidated to determine which selection criteria were the most important in that community. In subsequent analysis, the families that had the highest frequency in field and grain selection were selected to continue with the F₄-planting.

A very diverse range of selection criteria were identified but the most frequent were: resistance to rust, Anthracnose and powdery mildew; bush architecture (with a preferred height of 30-40 cm); uniform maturity; and a good yield (20-30 pods/plant). Farmers preferred a thick and heavy, longish bean. At this stage of selection, grain colour was excluded from consideration. Gender differences in selection criteria were not significant. It was noticeable that, although men had more experience in the field, the women found it easier to evaluate and select, rapidly seeing differences between traits in the different materials. Their evaluations and selections were often more discriminating than those of the men.

The field and grain evaluations continued in the four communities until the F₆ stage, as described in Figure 4.5. At that stage, ten materials selected by the communities and five materials selected on-station at EAP-Zamorano were put into comparative trials, along with a local control, *Concha Rosada*. The participating communities selected quite different materials to put in the comparative trials. This was partly due to different selection intensities and partly to different cultural preferences between the different communities. Other factors, such as environmental conditions, also played a role. For example, La Patastera CIAL made the broadest initial selections, with members retaining more than 50% (63) of the original F₃ materials. In F₄ they selected 23 materials but then subsequently lost all their selections in F₅ due to poor weather conditions. Two of the other communities, Mina Honda and Santa Cruz, over-selected at the outset (retaining less than 13%) which probably limited the genetic variability and hence the possibilities for making the best selections in F₄. The fourth community, Chaguitio, retained 19%. In short, selection in this first attempt at PPB occurred by trial and error with both farmers and the NGO learning along the way. In the following table, only the selections made between F₃ and F₅ in Mina Honda (the original collective site) are recorded. The complete list of

materials put into F₆ trials resulting from selections made by the three communities, as well as by the breeder, is given in the legend below Figure 4.5.

Figure 4.5 Outline of the participatory bean breeding programme in Honduras

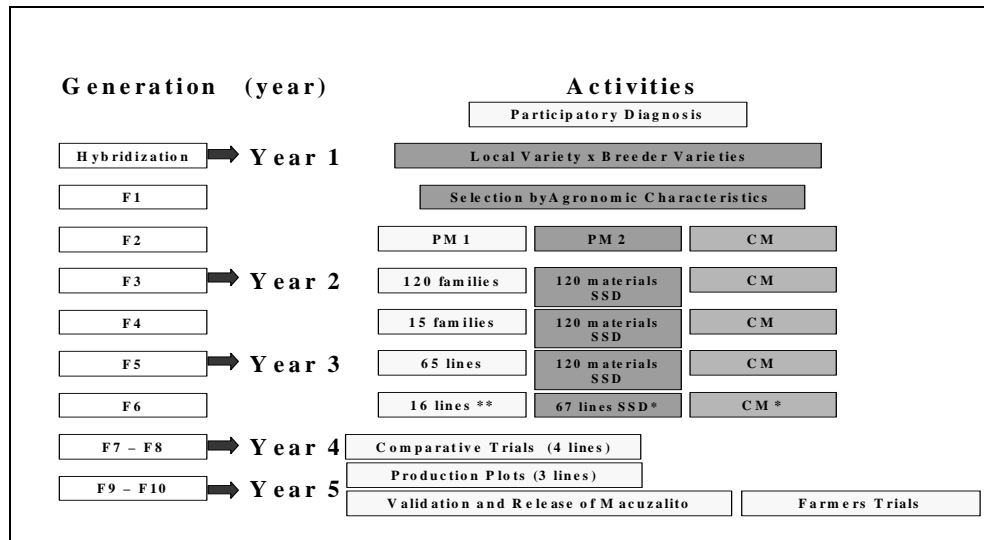

Legend:

PM1 Participatory Management 1: PPB conducted by farmers from F₃ in the community of Mina Honda.

PM2 Participatory Management 2: Single Seed Descent. At F₆, 67* materials were provided to CIALs by EAP-Zamorano for participatory selection in separate trials. None were eventually selected by farmers.

CM Conventional Management: Materials selected on-station at EAP-Zamorano.

* 5 best bet materials were provided to farmers for inclusion in PM1 F₆ trials.

** F₆ trials contained materials selected as follows: Zamorano: PPBY-5, -9, -11, -13, -15; Mina Honda: PPBY-1, -4, -6, -10, -12; Santa Cruz: PPBY-3, -8; Chaguitio: PPBY-2, -14, -7 + plus the local control (Concha Rosada). La Patastera lost its F₅ materials due to excessive rain and cold weather. The F₆ trials were conducted in the 4 communities: Mina Honda, Sta. Cruz, La Patastera, Chaguitio.

Results of the participatory trials

Farmers selected four lines for advancement from the F₆ trials; all four of these selected materials came from the local PPB trials, none of the breeder's selections were advanced beyond the F₆ level. The results of the F₇ trials are given in Table 4.10.

One of the lines (*PPBY-1*) was discarded in the F₈ trials owing to unfavourable agronomic traits. Three lines (*PPBY-2*, *PPBY-14*, *PPBY-8*) were advanced for production and subsequent validation. Macuzalito (*PPBY-8*) was later released as a new variety in August 2004 in the municipality of Yorito. As shown in Table 4.11, this variety was considered by farmers to show the best overall traits; the other two varieties had good individual traits but contained at least one drawback. Nevertheless,

these varieties were kept for local use because of their useful characteristics, such as earliness in the case of *PPBY14* (an important trait as it helps to shorten the hungry season) and high yield in the case *PPBY2*, which was beneficial for food security.

Table 4.10 Average yields in comparative trials in three Yoro communities, Spring 2002¹²¹

No.	Line*	Communities			Total yield (kg/ha)	Average yield (kg/ha)
		Santa Cruz	Mina Honda	La Patastera		
1	PPBY-8	1823	1686	2727	6236	2079
2	PPBY-14	1648	1629	2822	6098	2033
3	PPBY-2	1686	2008	2292	5985	1995
4	PPBY-1	1515	1610	2405	5530	1843
5	C. Rosada**	1515	1175	2386	5076	1692
6	Tío Canela***	1563	1023	1705	4290	1430

Notes: * Lines selected from F₆ trials: Mina Honda: PPBY-1; Chaguitio: PPB-2, -14; Sta Cruz: PPBY -8; ** Local Control; *** Universal Control.

Table 4.11 Farmers' evaluations of PPB varieties¹²¹

Attributes	PPBY-8 (<i>Macuzalito</i>)	PPBY-14	PPBY-2
Maturity	Moderate	Early	Late
Uniformity of maturation and colour	Uniform with attractive red colour	Uniform but a lighter red colour	Uniform but with white pods*
Disease tolerance	Medium	Medium-low*	Medium-high
Architecture	Excellent, medium height with well distributed pods	Good, low height* with well distributed pods	Good, medium height with well distributed pods
Yield	Good yield	Regular yield	Excellent yield
Commercial value	Good	Good	Poor*

Note: * Traits considered unfavourable by farmers.

Reflection on experiences

Empowerment

As mentioned above, PPB is a special case of participatory research with CIALs, and one that has greatly empowered farmers. Through PPB, farmers have not only acquired new knowledge (working with segregating materials, etc.) but they have also succeeded in creating a new variety from their own local material. This is a source of great pride as it signifies the importance of the conservation of local varieties by communities: the farmers are very aware that the successful outcome of the programme was due to their having conserved this material locally. This has provided a real impetus for the conservation of agrobiodiversity, and seed banks have been set up in six communities to continue this.

CIAL members are cognisant of the time and energy that they have invested in this process, in other words, of the opportunity cost of their labour, but they still think that it has been worth it overall. They feel they have invested in their future. Women feel particularly empowered as they have acquired new knowledge in an area formerly largely controlled by men. The recognition that CIAL members have received from other institutions has also been a powerful motivator for them, along with getting to know new people, networking, etc. Other benefits are less closely associated with PPB per se, but rather have come to them from their CIAL membership (e.g. loans, tools, and information) and from community infrastructure (e.g. meeting rooms).

Participants also mentioned difficulties encountered; the length of the process and the poor weather which caused setbacks and made the process even longer than anticipated. Some CIAL members had a hard time understanding PPB and had to be carried along by others in the group. Illiteracy was felt by some to be a real handicap that prevented people from fully grasping the process.

In a reflection on the process, three of the CIALs engaged in the project came up with the following definitions of PPB:

- “It is to improve a variety, get rid of the bad things that it has through crossing it with improved varieties and so obtain a better harvest. And it is participatory, involving the participation of men, women, technicians and organizations” (CIAL Mina Honda).
- “It is a process in which we make changes in the varieties, exchanging ideas with different actors: technicians, farmers and scientists” (CIAL Santa Cruz).
- “It is to change a variety: its appearance, its form, yield, etc. taking into account the criteria and experiences of all of the group or the community” (CIAL La Patastera).

Genetic selection and diversity

One of the side benefits of PPB has been to substantially increase genetic diversity in the participating communities. For example, in Mina Honda, the community has gone from relying almost solely on *Concha Rosada* to utilizing a number of new PPB varieties: apart from *Macuzalito*, Mina Honda residents have also adopted *Liberal* (PPBY-10), *Domínguez* (PPBY-2) and *Santa Marta* (PPBY-14) - varieties derived from the 15 lines evaluated during F₆ comparative trials that were multiplied and retained for local use. In addition, members selected a variety known as *Marvelino* from one of the early segregating materials that the breeder gave them to practice with at the very outset. One CIAL member from Mina Honda also retained a few lines from F₅ trials, took them back to her plot and together with her husband advanced these independently, eventually selecting one variety known locally as *La Esperanza*. Other earlier PPB materials discarded by the CIALs are undoubtedly present in the four participating communities and in local use. In addition, farmers have become reacquainted with a host of landraces, such as *Pedreño*, *Careto Negro and Rojo*, *Bocado*, *Carmelito* and others. Thus PPB has played an important role in highlighting the importance of conserving landraces. In these respects, PPB has contributed substantially to increased local agrobiodiversity.

Other findings and lessons

At the end of the PPB activities, a workshop was conducted in each participating community to gauge the reaction of CIAL members to the overall process. A great majority of participants said they would prefer to work with early generations (F₃) in the future, and some would prefer to carry out the crosses themselves. As people said, “in this way we learn more about how to improve seed” and “it is like raising a child and seeing it grow, knowing the part you played in it”. A few said they had invested too much time in PPB and would prefer to start at F₆; fewer still said they would prefer to restrict themselves to validating new materials.

The preference for continuing with PPB expressed by the majority of CIAL members is not surprising. In spite of the fact that advanced breeder materials have been, and continue to be, evaluated by the CIALs, they have not produced the anticipated results. While a few of the materials, e.g. *Amadeus-77*, are being used by farmers in low-lying areas, none of these materials have been adopted by farmers at higher elevations.

Institutionalisation of PPB

Macuzalito was ‘released’ in August 2004 and has since been tested and multiplied in 30 locations. Members’ associations in the national CIAL network are leading this process and results are being shared between the members. While the 2004 release took place at the municipal level, CIAL members still dream of having *Macuzalito* released at the national level once the extent of its adaptability has been assessed.

Macuzalito is being further improved by scientists at EAP-Zamorano through the inclusion of genes for resistance to Angular Leaf Spot Disease. To this end, 22 lines of *Macuzalito* have already been evaluated in Mina Honda, leading to the selection of five lines that are more resistant to the disease than the parent. These five lines were being evaluated at the time of writing. The same 22 lines are also being tested out by another CIAL in a different region of the country. Thus the improvement of *Macuzalito* is already under way, as are trials to test its adaptation in other regions. Whether PPB will be institutionalized through scaling out the farmer improved variety generated by the CIALs, or by seeking to introduce PPB into other communities where a CIAL does not exist, remains to be seen. However, given the skills involved, and the time and resources needed to support their development, it may be worthwhile to focus on the CIAL federation, rather than trying to replicate this process in communities where such skills and organizational forms are lacking.

Ownership of the PPB products

In August 2004, a special act of the Municipal Government of Yorito recognized the Yorito, Victoria and Sulaco regional CIAL Association as the rightful owners of *Macuzalito*; and prohibited commercial use of the seed. But can this be enforced? CIAL members have the advantage of knowing how to manage PPB but are generally not in a good position to profit from it commercially. They have small properties that are inadequate for commercial production. This means that others may become the beneficiaries of their investment and labour. And this is proving to be the case. Following the release of *Macuzalito*, several CIAL members involved in the PPB

process sold seed to wealthier farmers with access to irrigation. Supported by a large international NGO these farmers have multiplied *Macuzalito* in order to sell it back to the NGO for distribution. Similarly, FIPAH has purchased seed from the participating CIALs to take to other CIALs for testing in their regions. While this is certainly beneficial from the perspective of upscaling, there is little payback for CIAL members other than the personal satisfaction of knowing their variety is helping other poor farmers. It is hard to imagine that such altruism will stand the test of time and it is likely that some form of monetary incentive will be required in the future.

Outlook on the future

If PPB is to endure as an alternative to conventional breeding it may be necessary to provide appropriate incentives for participants. Since there is no readily available mechanism for providing protection for varieties created by farmer breeders (and farmers do not appear interested in seeking protection), breeding contracts should be sought to subsidize the difference between the external (social) benefits from PPB and private returns accruing to farmer-breeders. NGOs which support PPB will need similar financial assistance. PPB cannot follow the pattern of so many other activities that have been introduced into communities without available funds to support them. While PPB is an exciting new activity, it does, like all research, involve costs and these will have to be factored into future planning.

4.6 Farmer field schools supporting farmer-led participatory plant breeding: some Asian experiences

Hans Smolders, Arma Bertuso and Bert Visser

To ensure increased food security, national and international plant breeding schemes have worked on the development of favourable production systems, and have been fairly successful in releasing new high-yielding varieties. However, they have also found it impossible to cater for all farming systems, crops, household preferences and market conditions existing in farming environments. Participatory Plant Breeding (PPB) programmes* can offer advantages to farming communities in many different agro-ecosystems. Their success is not limited to marginal, heterogeneous or low-input farming systems that are often characterized by limited public and private breeding services; PPB can also succeed in favourable high-production environments that are already covered by national plant breeding schemes.

* Walter de Boef and Juliana Bernardi Ogliari (Section 4.1) provide more details on definitions of Participatory Crop Improvement (PCI), Participatory Varietal Selection (PVS) and Participatory Plant Breeding (PPB). The authors of the current section follow a different categorization, using PPB as an overall term and distinguishing between breeder- and farmer-led PPB.

In PPB, farmers participate in breeding and selection programmes to various degrees. Their participation is not limited to the evaluation of end products; more and more farmers are involved in the setting of selection criteria, evaluation of early and advanced lines, and even in the selection process itself. In contrast to formal-led approaches, where farmers participate in institutional PPB programmes, farmer-led approaches allow farmers to decide on their own crop selection criteria and breeding methodologies. Research linkages in this new and innovative PPB approach are established in a collaborative atmosphere.⁸⁴ A number of PPB programmes in Asia have conceptualized this farmer-led PPB approach for a Farmer Field School (FFS) context.

In this section, we present experiences from two regional NGO-managed PPB programmes in Asia: the Biodiversity Use and Conservation in Asia Programme (BUCAP) and the Participatory Enhancement of Diversity of Genetic Resources in Asia Programme (PEDIGREA). Carried out by various institutions and in several countries, the programmes have much in common. Both are spin-offs of the Community Biodiversity Development and Conservation Programme (CBDC), a global on-farm biodiversity programme established in 1994. They focus on rice, Asia's farmers' staple crop. Both BUCAP and PEDIGREA have adopted the FFS approach as the key pedagogical and institutional approach to technology transfer, facilitating farmers' learning, and upscaling. It should be noted that the FFS approach can cater equally well for formal-led and farmer-led approaches to PPB.

Scope of the programmes

The BUCAP programme started in 2000 and is carried out in North and Central Vietnam, Laos PDR and Bhutan. BUCAP is implemented by the Southeast Asian Regional Initiatives for Community Empowerment (SEARICE), a Philippines-based NGO, and funded by a number of international donors. The objective of BUCAP is to use PPB to strengthen on-farm management and use of plant genetic resources. The start of the BUCAP programme marked two major changes in approach. Firstly, from the outset, BUCAP involved not only farming communities, but also government research and extension institutions. The idea behind this was that support and acceptance by breeding institutions would be important to anchor PPB approaches in national development strategies. Secondly, BUCAP adopted PPB as a way not only to conserve traditional varieties, but also to utilize them to develop varieties better adapted to local production environments. The countries in BUCAP represent a diverse selection of rice cultivation environments and conditions, ranging from subsistence farming (Bhutan) to irrigated lowland production, with a strong orientation towards commercial markets (Vietnam).

The PEDIGREA programme was established in 2002 and is carried out in Indonesia, Cambodia and the Philippines. PEDIGREA aims to develop novel sustainable farmer-led approaches in PPB. There is close collaboration with research institutions and scientists to provide complementary services and guarantee maximum input. Unlike BUCAP, PEDIGREA has adopted a farming system approach, addressing diversity in a farming community by focusing not only on the staple crop, rice, but also on other crops such as vegetables, and on livestock such as goats and

pigs. PEDIGREA activities are carried out in farming communities with intensive rice production, characterized by cultivation of large acreages of modern varieties and a low degree of diversity, yet with limited cultivation of some highly appreciated traditional varieties. Apart from rice, its main focus is on local indigenous vegetables, often the main source of farmers' income and a source of enrichment of the community's diet. National breeding programmes for these marginal crops are either lacking or are considered very weak. The uniqueness of PEDIGREA is that market research has been integrated into PPB.

PEDIGREA is carried out in partnership between three local NGOs that coordinate the respective country programmes: Farmers' Initiatives for Ecological Livelihoods and Democracy (FIELD) in Indonesia, SRER KHMER ('Field of Cambodia') in Cambodia, and People, Plants Research and Development Inc. (PPRDI) in the Philippines. Backstopping is provided by three partners: the Centre for Genetic Resources, the Netherlands, the Agricultural Economics Research Institute of Wageningen University and Research Centre, and Bioversity International, Asia and Pacific Office in Malaysia. The overall management lies with the PEDIGREA foundation based in Manila, the Philippines.

The Farmer Field School framework

The common ground between BUCAP and PEDIGREA is that both have adopted the FFS concept as the key approach. The FFS provides farmers with a structured way of learning, problem solving and decision making; it facilitates structured co-operation between research/extension and farmers. Pioneered in the 1980s by the FAO in Indonesia, the FFS approach was embraced by state and local governments in Asia as an effective tool for agricultural extension on integrated pest management (IPM). In developing the curriculum for PPB, both programmes benefited from this history, as the concept was well known among NGOs, government and rural communities. PPB could be built within FFS with experienced local trainers.

In an FFS, farmers get together in weekly or bi-weekly meetings for the duration of one full cropping season to study particular topics in the curriculum. Basic topics in the curriculum on PPB include understanding genetic diversity and crop improvement, baseline assessments, participatory variety selection, and variety rehabilitation. When possible, crop hybridization and selection in segregating populations are included. After the first season, small groups of interested farmers are formed who continue with variety selection and breeding per crop under the guidance of an experienced farmer, extensionist or NGO trainer. In PEDIGREA, a sequential approach is used, targeting the same farming community. In the first season, an FFS on rice is conducted, usually followed by an FFS on vegetables in the next season, and where possible with an FFS on vegetable marketing or working with farm animals.

Field guides on PPB implementation in FFS have been published by BUCAP¹²² and PEDIGREA.¹²³ The latter also included an FFS curriculum on PPB for vegetables. Simultaneously, PEDIGREA published a booklet with framework information on the development of FFS programmes in participatory plant breeding, including the concepts underlying FFS, preparatory activities, FFS implementation, and guidelines on how to upscale and monitor.¹²⁴

In the six countries, farming communities responded enthusiastically. The involvement of national research and extension institutes varies among the countries and regions. The BUCAP projects are relatively well structured while the PEDIGREA projects operate more informally. We will present a selection of cases of the activities with relevance to rice and vegetables.

Case studies on participatory plant breeding in rice and vegetables

BUCAP country experiences in breeding rice¹²⁵

Agriculture in Bhutan is characterized by subsistence farming. In Bhutan, BUCAP is coordinated by the National Biodiversity Centre of the Ministry of Agriculture, responsible for *ex situ* conservation and policy formulation, in partnership with the agricultural research institutions and the agricultural extension agencies. The FFS approach was introduced by BUCAP in this country in 2002; it involved farmers directly in participatory varietal selection (PVS), and focused on the selection of rice blast resistant varieties. This focus was inserted into the PVS activities following a severe outbreak of rice blast at high altitude (1800-2700m) production environments in 1995. The materials used were crosses between local and improved varieties made by researchers in the research centre. Parents were selected on the basis of the farmers' feedback. The early generation materials were evaluated on-station by researchers and farmers on the basis of the plant type, maturity, and disease resistance. After a number of generations, fairly uniform and disease-free lines were bulked. From F₅ onwards, promising lines were selected and included in the PVS trials in farmers' fields, facilitated by a host farmer, together with other variety introductions and local checks. Assessment of the materials was performed using ranking tools, including matrix ranking, based on preferred criteria such as yield, kernel colour (red), disease resistance, maturity, taste, height, easiness of threshing, grain type, and straw yield. However, a majority of farmers considered yield and yield stability as the main criteria. The collaborative programme works with farming communities in different valleys of Bhutan. The programme has thus far succeeded in increasing the diversity of blast resistant varieties in farmers' fields, and has released two improved local blast resistant rice varieties, namely *Yusirep Maap* and *Yusireay Kaap*.

In Laos PDR, BUCAP is coordinated by the Plant Protection Centre of the Ministry of Agriculture and Forestry. It is carried out in four provinces and involves a number of partners, including provincial secondary schools, agricultural extension, and for backup technical support and material, the Nappok Agricultural Research Centre. This research centre is responsible for rice breeding in the country. It has supplied the provincial BUCAP programmes with modern and traditional varieties for PVS, and breeding populations in the F₃-F₆ generations for further selection in farmers' fields within an FFS context. The impact of BUCAP in Laos PDR is uneven. Progress is notably hampered by regular adverse weather conditions and by low farmer participation in the FFS. Participation by women is especially limited. Nevertheless, farmers evidently have improved their skills through BUCAP and the programme has strengthened varietal diffusion and contributed to an increased awareness of genetic diversity among farmers.

The BUCAP Vietnam Programme is an example of an extended farmer-led PPB approach, characterized by collaboration with formal institutions. Between 2000 and 2002, PPB projects were started in five provinces. Its successes led to the programme being expanded to include five other provinces. The programme is being implemented in a wide range of environments, including both rain-fed and irrigated rice production systems. As in Laos, Indonesia, Cambodia and the Philippines, the BUCAP programme in Vietnam is linked to the extensive and successful FFS-IPM efforts in rice. The high level of organization of farmers in communes and their familiarity with FFS were important contributing factors facilitating the success of the programme in Vietnam. In addition, both state and local government gave key support to FFS activities and local seed multiplication. For example, the government exempted farmers from land taxes if they were engaged in seed production, and compensated farmers who used land for BUCAP experiments.

Varieties and segregating materials supplied to farmers for PVS and PPB originate from various breeding institutions. FFS activities included PVS, variety rehabilitation, PPB and seed multiplication. Farmers themselves also made many crosses between local and high yielding varieties, with the objective of increasing yield while retaining local adaptedness and preferred culinary traits. Government plant breeders provided advice on breeding methods and training in crossing, but the farmers maintained a high level of autonomy through their communes. Until now, hundreds of FFS have been organized in villages. Remarkable results were obtained in rehabilitating local varieties through mass selection, and yield increases of more than 20% have been reported. In the Northern Hoa Bin province alone, the BUCAP programme has contributed to the restoration (purification) and seed multiplication of 17 traditional varieties, and the selection of 8 stable lines from farmers' and breeders' crosses. Early successes include the varieties *MD1*, *MD2* (originating from Mo Da Village) and *TX1*, *TX2* (from Tam Xuam village), which are now being multiplied and planted by farmers in the region.¹²⁶

*PEDIGREA country experiences in breeding rice*¹²⁷

The PEDIGREA country projects are entirely farmer-led. The programme is designed such that farmers, and not researchers or NGOs, are responsible for the decisions on breeding objectives and approaches. Experienced farmer-breeders cum trainers coordinate FFS programmes through local farmer forums. By 2005, some 30 farming communities in the PEDIGREA countries were participating in rice FFS, involving 1437 farmers, both men and women. Good collaboration has been established with local authorities, providing support to FFS, and allowing extension staff to participate in the FFS as trainers. The projects are supervised by the local partner NGOs, who support the FFS activities through liaison and lobbying with national and local authorities and research institutes, and internationally with other PEDIGREA partners. NGOs and partners, including government rice breeders, provide backstopping in terms of curriculum development, participation in Training of Trainers workshops and in regional seminars.

As in BUCAP, the FFS on rice involves setting of breeding objectives through participatory baseline surveys, PVS, variety rehabilitation, parental crosses, and

selection within segregating material. Initial breeding materials for the FFS included early and advanced lines, supplied by government rice research stations. Most material was taken from surplus stock of the institutions' breeding programmes. Farmers report that selection within these materials is promising but not very effective. In the Philippines, restrictions on diffusion of farmer selected varieties apply as the rice research institute uses a material transfer agreement to claim breeder's rights of farmer-made selections from their materials. Farmers currently produce most of their crosses themselves, using improved and traditional varieties as well as promising advanced lines in their crosses.

Bottlenecks encountered in the selection programmes are land scarcity, storage facilities for seed selections, and the relatively small size of the breeding populations. Interestingly, there are few problems with sustaining the interest of farmers for the duration of the breeding cycle. Habits of sharing of tasks and land in the community breeding programmes gradually develop, enabling farmers to deal with the above-mentioned problems. Three categories of farmers can be generally identified within the participating communities. A few individual farmers who are skilled breeders and run their own rice breeding programmes, select parents and perform crosses. A second category of farmers grow out and evaluate segregating selections, supported by the farmers in the first category. The third category of farmers is not actively engaged but interested in further testing and growing the products of farmer-led PPB. This would appear to provide some evidence that a few skilled farmer-breeders can be sufficient to support others and serve as a source of farmer-bred material for the rest of the community and neighbouring areas, thus sustaining the farmer-led PPB programme in the longer term.

PEDIGREA has proven to be a genuinely low-cost effort. Small allowances have been provided to national researchers, farmer-trainers and extension staff participating in the Trainings of Trainers workshops. Major costs are covered by the farmers themselves. In some cases, small grants and land were provided free of charge by the municipality. Support from local governments was often instrumental in public relations (e.g. advertising).

Until 2005, farmers have made over 200 crosses in rice. In the Philippines, crosses were made primarily with tungro virus-resistant rice varieties and in Indonesia with brown plant hopper (BPH)-resistant lines. Farmers used modified pedigree selection as the main selection method, involving mass selection during the F₂-F₄ followed by ear-to-row selection in the F₅ for selection on yield and taste. Results are promising. In the three countries, farmers have thus far evaluated 218 varieties through PVS, and are currently managing 26 promising advanced lines in the framework of PPB. In the Philippines, one high-yielding, good-tasting farmer-bred variety (*Pagasa 97*) and one with tungro virus resistance (*Jemar 6*) are being tested on a larger scale by farmers in the municipality.

PEDIGREA: methodologies in breeding local vegetables

The PPB programmes on local vegetables in PEDIGREA take a different approach to the rice programmes, focusing on two or three crops simultaneously and linking PPB with the local markets by integrating market research into the FFS programme. Since

the start in 2003, cucurbits comprised the major share in Indonesia and Cambodia. Other crops included are wax gourd and pumpkin in Cambodia, pumpkin, loofah and bitter melon in Indonesia, and eggplant, pumpkin and yard-long bean in the Philippines. Farmers are directly engaged in comparing varieties through PVS, using trials of between 5-15 varieties with a single replicated design. Varieties tested had been collected by the farmers from neighbouring villages, distant markets, districts and provinces, and included exotic varieties introduced by the PEDIGREA team. Useful starting materials were provided by vegetable breeding programmes in the region. By 2005, a total of 125 varieties of these vegetables had been evaluated.

Once the FFS programme continued, farmers learned to perform crosses. They showed great enthusiasm, which quickly resulted in a large number of crosses being made. They focused particularly on cucurbit crops, which are relatively easy to hybridize because of their monocious flowering habit. Between 2003 and 2005, farmers made a total of 134 crosses and managed to produce 6 advanced lines of vegetables. After storage, seeds were replanted in relatively small plots of maximum 200 plants. Farmers used mass selection methods or a modified version of mass selection, involving extensive manual crossings of selected siblings in the early generations to avoid unwanted offspring. Farmers also started to experiment with back-crosses. During the baseline survey, selection criteria were set; farmers observed the materials in the field, and analysed them using matrix or other ranking tools comparing the varieties for agronomic characteristics, taste, texture, appearance, cooking and storage quality.

Market studies were undertaken with farmers and traders in nearby city markets to identify consumer preferences.¹²⁸ Such market studies received considerable interest from farmers as they could better understand the market mechanism, and identify niche markets for non-mainstream vegetable products. Results were fed back into the PPB programme, which in Indonesia led to the start of a cross breeding programme involving a smaller type of bitter melon. In Cambodia, crosses involved local slender wax gourd types and introduced round types; the latter showed high tolerance to wet production conditions. To date, the vegetable PPB programme remains a pilot programme that is closely monitored by PEDIGREA partners.

Reflection and outlook on the future

From the BUCAP and PEDIGREA experiences in Asia, two immediate lessons can be learned. Firstly, PPB has an empowering effect on farmers, which motivates them to continue with development, selection and breeding activities. An important aspect of farmer empowerment through PPB and FFS training is that it tends to change the relationship between research and extension services, changing farmers from recipients of top-down knowledge to participants in a more equal partnership. A number of plant breeders have clearly had difficulty in accepting the rather distinct concepts and objectives of the proposed farmer-based PPB, in which breeders play only a supporting role and seem to receive little identifiable credit. Whereas in BUCAP this problem has been addressed from the start by a collaborative structure, PEDIGREA has chosen to strengthen and empower farmer communities first, in order to ensure farmer-led PPB approaches from the start. In most cases, closer

interactions between breeders and farmers proved rewarding for both; farmers got access to germplasm and were trained in selection techniques, and breeders found additional testing grounds for their breeding materials.

Secondly, the FFS concept has proven to be an effective institutional approach for addressing the needs of the farmers, while at the same time facilitating the process of upscaling. The structured approach of FFS and the familiarity of local governments and research institutes with the concept has allowed for early adoption into government programmes in Bhutan, Laos PDR and Vietnam. In turn, this facilitates upscaling and addressing policy related issues, as well as acceptance of farmer-led PPB and farmers' varieties by the formal sector, a process which has to be followed up and still has to be addressed in the PEDIGREA projects in Indonesia, Cambodia and the Philippines. The slightly different approaches taken by BUCAP and PEDIGREA respectively have resulted in dissimilar and complementary lessons.

Postscript

After training events in Mali (2003) and Sierra Leone (2005) in the context of the Community Biodiversity Development and Conservation Programme and FAO, a PEDIGREA-like FFS programme was started in Ethiopia in 2007 under the name PEDIGREAF, in which the AF stands for Africa. This FFS-based farmer-led PPB programme is the initiative of the local NGO Ethio-Organic Seed Action Project (EOSA) and the Centre for Genetic Resources, the Netherlands.

5 Small-scale and community enterprises: increasing local availability of seed and enhancing farmers' access to it

5.1 Supporting the development of small to medium-scale seed enterprises in sub-Saharan Africa

John F. MacRobert

Seed enterprises have the potential to significantly improve the supply of improved varieties to farmers. Recent estimates indicate that approximately 66 to 85% of seed used by resource-poor farmers in sub-Saharan Africa is derived from informal markets.^{129,130} While informal seed supply is important for maintaining indigenous seed systems, there has been much progress in the development of improved varieties of many crops through conventional plant breeding.^{129,130} However, there has been an increasing appreciation of the need to involve farmers in breeding and variety evaluation, and of the value of testing varieties under conditions experienced by farmers.* Consequently, new varieties are not only improved over existing varieties in terms of yield and important agronomic traits, but they are adapted and appropriate to the farmers for whom they are developed.

In order for farmers to access new and improved varieties, the development of the formal seed sector is considered essential.¹³⁰ In recent decades, donors and governments have thus introduced numerous seed projects in Africa that have mostly concentrated on the development of the public seed sector. Nevertheless, many of these projects have also recognized the importance of the private sector in seed delivery systems. The inclusion of the private sector is considered to be necessary for sustainability, market development, and competitive pricing and product provision. The current section provides general background to strategies supporting the establishment of small to medium sized seed enterprises. It shares some concepts and some experiences of working with this strategy in various countries in sub-Saharan Africa. Most importantly, it highlights a number of the most relevant factors for creating the conditions conducive for their development in the African context.

Status of small to medium sized seed enterprises

Currently in Africa, there are but five or six countries with highly developed private seed sectors that have maize seed sales in excess of 6,000 tons per year. Although

* Chapter 4 on participatory crop improvement and supporting local seed supply discusses in detail the methodologies for participatory varietal testing referred to in this section.

most other countries have formal seed sales of less than 6,000 tons, numerous private seed companies are emerging. In 2007, the author noted 65 maize seed companies in 13 countries of east and southern Africa. A number of these had operations (both production and marketing) in several countries. Although seed maize sales figures are confidential and hard to come by, the author estimates that only five companies have total maize seed sales in excess of 10,000 tons, while perhaps two thirds of the companies sell less than 2,000 tons and may therefore be classified as small to medium sized seed enterprises.

Many small to medium sized seed enterprises* play an important role in seed delivery to farmers. They are often operating in emerging markets which may not be as attractive to large companies, they are generally restricted to single countries or to specific locales within a country, and they tend to have lean and efficient corporate structures. It may be expected that, as the private sector develops within a country or region, the number of seed companies will increase (Figure 5.1). This will bring about a concomitant increase in the number of varieties available to farmers, which will be associated with an increase in the seed purchase frequency (i.e., the number of farmers buying seed annually), and may also lead to a decrease in the product life-cycle as farmers demand improved varieties and as seed companies compete for market share. Consequently, the development of small-scale seed enterprises should serve as an important stimulus to providing improved seed to rural farmers at competitive prices and in accessible places, which in turn should tend to promote farmer productivity.

Figure 5.1 Schematic presentation showing the effect of a developing seed sector on the number of seed companies, the number of crop varieties available, the seed purchase frequency, and the product life-cycle

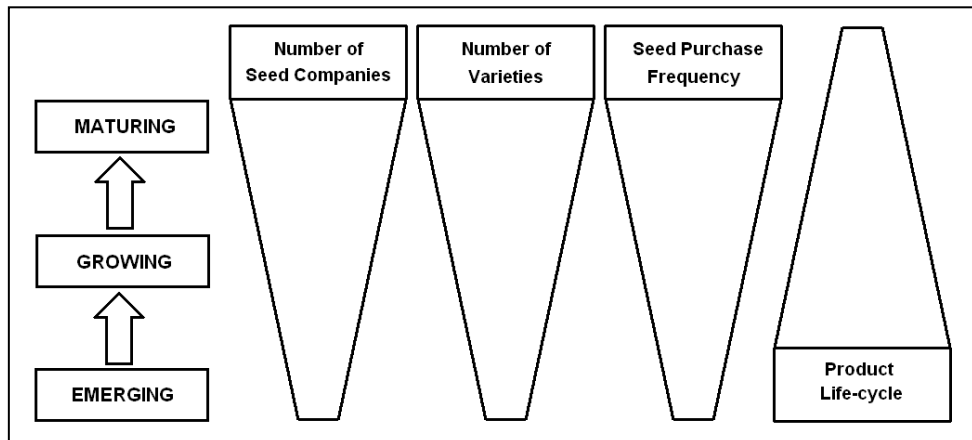

* In the remaining section, when small-scale seed enterprise is referred to, this includes medium-scale seed enterprises.

Components critical to the success of a small and medium sized seed enterprise

The seed-related components of a seed business range from product development to marketing and sales ('the seed chain': Figure 5.2). At each stage of the process, there are related management aspects that impact on or are necessary for the flow of a new variety to the farmer. Most large seed companies manage all the components of the seed chain, and are therefore relatively self-contained. Small-scale seed enterprises, however, tend to concentrate on the components closer to the farmer, notably seed production, processing, marketing and sales, while depending on public sources of varieties because of the high costs of variety development.

Figure 5.2 The "seed chain" showing the main components of the flow of seed from variety development to the farmer, and the associated key management aspects for each stage

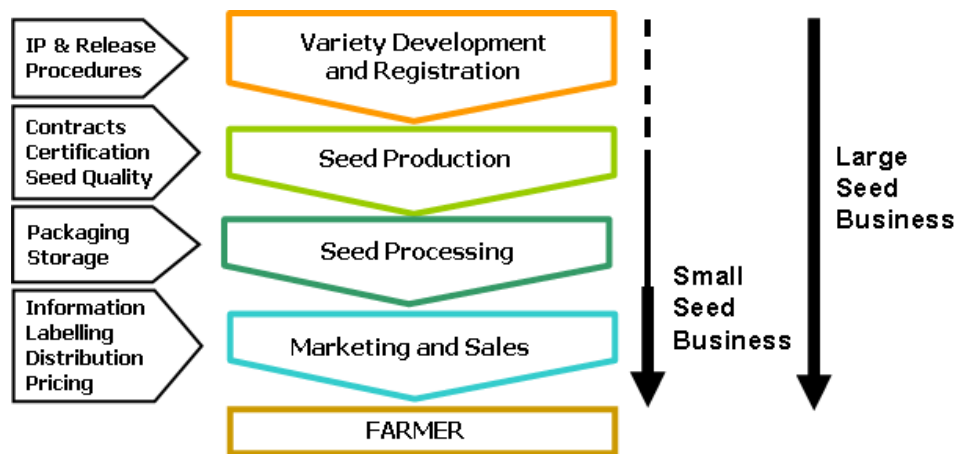

Thus, access to improved, adapted and appropriate varieties is critical to establishing the product portfolio of a small-scale seed enterprise. This access to varieties may also include the provision of adequate quantities of breeders' and even pre-basic or basic seed. The enterprise must be able to manage the remaining components of the seed chain to ensure sufficient supplies of seed to the market. This requires the establishment of a seed grower base, and access to or establishment of a seed processing facility. A seed company must also develop marketing and sales strategies to ensure that income is generated for the enterprise. Furthermore, the small seed enterprise needs to be able to manage the finances, human resources and infrastructure of the company to remain viable in the long run. This highlights the importance of the general management of an enterprise for success.

A seed enterprise does not exist in isolation from national agricultural policies nor from the general economic and developmental activities of a country. Hence, from a broader perspective, a number of approaches may be proposed that will likely support the development of small-scale seed enterprises.

Germplasm provision from public sector institutes to private seed enterprises

In sub-Saharan Africa public entities generally develop new varieties; they consist of National Agricultural Research Systems (NARS) and International Agricultural Research Centres (IARCs). Although IARC germplasm is an 'international public good' and available to the public and private sectors, germplasm developed by NARS has not always been viewed as such. Consequently, access to NARS germplasm by small-scale enterprises in some countries has been difficult. There are, however, a number of recent examples where NARS have made varieties available to the private sector on a contractual basis (e.g., Kenya, Malawi, South Africa, Uganda, Zambia, and Zimbabwe). This is a positive development and has fostered the emergence of many small-scale enterprises in these countries. Such contractual arrangements are usually restricted to the country of the particular NARS. The possibility of extending these contracts to other countries would be a welcome development as it would facilitate a much wider distribution of improved public varieties across sub-Saharan Africa.

Ensuring access to foundation (basic) seed

The establishment of foundation (basic) seed enterprises has been proposed as a key element for small-scale seed enterprise development in sub-Saharan Africa.¹³⁰ This concept includes not only the provision of germplasm (i.e., new varieties) but also variety maintenance, the provision of pre-basic and basic seed, and the establishment of contract processing facilities that may be accessed by seed enterprises. Variety maintenance and basic seed production is a specialized task for which neither public germplasm providers nor small-scale seed enterprises may have the capacity or inclination. Foundation seed enterprises may therefore provide this service, thus creating the level of foundation seed security that they need, especially in the emergence phase of their development. An example of such a foundation seed enterprise is the USEBA project in Mozambique.¹³¹

Initiating quality seed production

Certified seed production by seed enterprises is usually carried out with individual farmers. The regulations for certifying seed production include provisions for distance or time isolation to ensure genetic purity of the seed crop. Although isolation distances for self-pollinated crops are usually tens of metres, isolations for cross-pollinated crops, such as maize or sorghum, are usually several hundred metres. Such large isolation distances are usually possible with large-scale farmers, but are more difficult to achieve with closely associated small-scale farmers typical of most African farming systems. Thus, small-scale seed enterprises need to develop strategies to establish community-based seed production schemes. Many independent community-based seed schemes have been attempted in Africa with varying success.^{130,132} The sustainability of these schemes may be better assured if they were directly integrated with commercial seed enterprises.

*Facilitatory seed regulations**

Seed regulations serve as a means of assuring the quality of seed, safeguarding the phytosanitary integrity of a nation, identifying varieties and protecting the intellectual property of the originators of varieties. The status of seed regulation is far from satisfactory in Africa, with few countries having comprehensive seed legislation in place.¹³³ Furthermore, there are often differences between neighbouring countries in the nature of their seed regulations. Consequently, seed enterprises often function with a high degree of uncertainty regarding seed certification and variety protection, while farmers have little or no protection from unscrupulous seed traders. Furthermore, trans-border seed business opportunities are often hampered by inconsistencies in seed regulations amongst nations. It is therefore important that seed regulations be instituted in countries where they are non-existent or deficient, but it should also be noted that strict government regulation may act as a disincentive for the emergence of a commercial seed sector.¹³⁰

Provision of seed stockist training

Seed marketing is a key component of a seed enterprise. However, farmers in sub-Saharan Africa are numerous, diverse, scattered and generally operate on a small scale. Hence, an individual farmer does not account for a significant proportion of the total sales of a seed business.¹³⁴ Small-scale seed enterprises are therefore faced with a seed distribution problem that is probably best solved by marketing through agents, retailers or wholesalers. Such intermediaries are not always aware of the potential of the seed trade or of the issues involved in stocking seed, such as storage requirements, seed viability, farmer variety preferences, etc. Training of seed stockists will probably help to overcome this deficiency of information and provide incentives to retailers to sell seed.

Seed business management training

Seed businesses are unique in that they deal with a product that may take two to four years to reach the market because of the need for multiplying seed through the various seed classes to reach the volumes required by farmers. As mentioned above, there are various integrated components in the seed chain that are quite different from a manufacturing or retail business, while the financing of seed production has a medium to long term cycle. In principle, seed enterprises require the same basic business and technical strategies as all businesses, but they also require some different approaches of their own, and emerging seed entrepreneurs would therefore probably benefit from appropriate training and mentoring programmes.

Linking output markets, seed enterprises and farmers

Farmers may not have an incentive to purchase seed of improved varieties if the extra grain production arising from the use of the seed does not have a ready market. There are examples where seed companies have expanded their business through the

* Chapter 7 elaborates on creating enabling policy frameworks and seed regulations supporting informal seed supply.

integration of output markets that have specific variety requirements with farmers who produce the required product. Although these have largely been related to the horticultural industry, the concept has been applied successfully to field crops, such as confectionary groundnuts, dry beans for the canning industry and various kinds of maize (e.g. green maize, popcorn and quality protein maize).

Creating awareness amongst credit suppliers of the nature of seed businesses

The seed business is typified by medium to long cash flow cycles and short periods of sales activity at certain times of the year. Consequently, small-scale seed enterprises may experience long periods of cash flow deficit during the seed production phase, and short periods of cash surplus during the sales phase. Therefore they require long-term financing of operations. This may be perceived by credit institutions as a higher risk than manufacturing or retail businesses where cash flow cycles are short, and so small-scale seed enterprises often face difficulties in accessing credit. This problem may be overcome through initiatives that create awareness amongst credit suppliers of the nature of the seed business.

Extension services and information provision

A major constraint to the development of small-scale seed enterprises is the generally low effective demand for seed in Africa.¹³⁵ This is related to the generally high seed: grain price ratio, low crop productivity and lack of availability of output markets. On the assumption that viable output markets are available, crop productivity increases help to mitigate high seed: grain price ratios, simply because the seed cost becomes a relatively smaller proportion of total income from the crop. Extension services that promote farmer development and facilitate improvements in crop productivity will therefore probably contribute to increasing farmers' demand for seed.

Information useful to seed sector development is not limited to that required by farmers to increase their crop productivity. Three types of information can be proposed that are necessary for seed system development,¹³⁰ *viz.*, technical information about seed systems, economic indicators of input and output markets, and information about the partners involved in the seed system. Seed Trade Associations and regional seed-related organizations, such as the SADC Seed Security Network, are playing an important role in this matter.

Rationalizing seed relief schemes

Natural disasters are not uncommon in Africa, and relief agencies have annually distributed large quantities of free seed to affected and vulnerable households.*¹³⁶ Although this presents a market opportunity for small-scale seed enterprises, there is a growing recognition of the quality problems associated with much of this seed, and of the fact that free distribution undermines the sale of seed through commercial wholesale-retail trade networks. Alternative approaches to free seed schemes, such as redeemable vouchers and community seed fairs, have been proposed and used. Seed

* See also Section 2.5 by Asrat Asfaw, Anbesse Tenaye and Endrias Geta on seed relief interventions in Southern Ethiopia.

relief schemes are also prompted by random natural events and so do not serve as a long-term viable market that can be nurtured and developed. Thus, from a seed company perspective they are opportunistic markets. To overcome the past quality problems and the opportunistic nature of seed relief schemes, relief agencies may consider pre-contracting small-scale seed enterprises to produce and store seed in preparation for future disasters.

Conclusion

Seed of improved varieties has the potential to significantly promote the well-being of farmers in sub-Saharan Africa. Although many improved varieties of a range of crops have been developed by public institutes, farmers' access to seed of these varieties is hindered by a poorly developed seed sector in much of the continent. The development and promotion of small and medium sized seed businesses are a potential solution to this problem. Approaches to stimulating the private seed sector include making public varieties available to private seed companies, establishing foundation seed businesses, linking small and medium sized seed enterprises with community-based seed schemes, encouraging the formulation of national seed regulations that facilitate the development of the private seed sector, providing seed business training opportunities, and finding ways of stimulating output markets and farmer productivity.

5.2 Business principles for the establishment of a viable small-scale seed enterprise

Anthony J.G. van Gastel, Zewdie Bishaw and Bill R. Gregg

Large-scale formal seed supply has had limited success in providing farmers with seed in sub-Saharan Africa including Ethiopia and many other developing countries.^{129,130} In the first two chapters of this book, various authors have described this situation and suggested some alternatives for increasing seed supply by supporting the informal sector. As a result, in many developing countries, changing government policies are encouraging the diversification of the seed sector, and stimulating the emergence and participation of the private sector in the national seed industry. Within this context of liberalization it is expected that many small- to medium-scale seed enterprises are emerging to provide seed to farming communities. The basis for such policies is that the seed business is considered important for the farming community. Its establishment supported agricultural development in Europe and North America, and is now doing the same in various Asian countries. Seed companies help farmers to access good quality seed of a variety of crops and achieve higher yields. They should also provide seed in periods of seed insecurity. Furthermore, local seed companies can play an important role in introducing new crops and varieties, advising farmers and providing them with other agricultural inputs such as fertilizers, pesticides and small agricultural tools. The current section presents a general outline of principles that

guide the establishment of a small-scale seed enterprise. First, it elaborates the options for seed production as a business. An important tool for the design of a small-scale seed enterprise is a business plan. The section describes the various components of such a plan, including a marketing plan, a seed demand survey, and financial, operational and legal issues. Such an integrated approach to planning a seed enterprise is critical for establishing a technically and economically viable business, independent of project or other funding. The other sections in this chapter illustrate a wide range of strategies for establishing small-scale or community-based seed enterprises as a way to make seed more readily available and accessible to smallholder farmers. However, this section does not set out to provide a blueprint.

Seed as a business

A seed enterprise is a business that produces and sells quality seed and other services cost efficiently with a view to making a profit. Its activities include seed production, processing, storage and marketing. A successful seed enterprise requires skilful management of physical, financial and human resources. It provides customers (farmers) with the products they want, at the time that they want them, at the place where they want them, in the quantities and qualities they require, and at prices they can afford to pay.

Inadequate initial planning, poor management, lack of know-how, insufficient capital, strong competition and lack of understanding of market/customer needs are the main reasons why such enterprises fail. Therefore, the start-up of a seed enterprise must be preceded by detailed analysis of its feasibility to obtain a clear, accurate and comprehensive picture of the planned enterprise and its profitability by preparing a comprehensive business plan. The larger the proposed enterprises (and the bigger the investment), the more formalized and comprehensive the business plan must be. Where outside funds (loans) are required, a comprehensive business plan is a prerequisite.

Business plan

A business plan is a detailed study of all the factors affecting the performance of a planned enterprise, and it serves as a strategic planning document for the company. It assesses the strengths, weaknesses, risks and profitability of the enterprise in real market situations. The business plan is also a prospectus both for lenders and investors. It provides detailed information about starting the business as well as a management and financial blueprint for profitable operations. The plan anticipates the market development, and economic and policy issues. It provides guidelines for managing the enterprise's growth and strengthening its position as a supplier of services. A business plan has several components (Figure 5.3), including marketing, financial, operations, and management plans.

Marketing plan

Analysis of failed business enterprises has shown that a company must focus on the market rather than the technology or the product. This is called the 'marketing concept', which is an approach to doing business that says that satisfying the needs of

customers is the justification for the existence of the enterprise. For a seed enterprise this means that the seed market is the central issue, and that all its activities (planning, production, quality control, processing, storage, marketing, distribution) are driven by the need to satisfy farmers' needs, while making a reasonable profit. Not only every operation, but also all the staff members must be market conscious. The first and most important tool for a seed entrepreneur is to develop a realistic marketing plan; a detailed, in-depth analysis of what seed farmers in the target area are likely to buy, when they will buy it, what price they are willing to pay and how the seed can be sold. The marketing plan helps the entrepreneur to forecast production and processing operations and provides the basic financial information.

Figure 5.3 Essential components of the business plan



Market research and analysis

The preparation of a marketing plan requires a seed demand survey and an analysis of information. All possible sources of information must be used to ensure that it is realistic and accurate. Visits should be made to farmers who regularly purchase seed as well as those who are potential customers. The following questions should guide the survey.

- Who will be the customers of the enterprise?
- How many potential customers are there?
- What are potential customers' primary crops?
- What quantity of seed do they buy?
- How much are they willing to pay for seed?
- What market share can you expect?
- Why should customers buy from the enterprise?
- Will your enterprise be conveniently located?

Useful information can be obtained from government agricultural institutions (ministries, research, development agencies, extension services, etc.) and credit services (banks, lenders, etc.), as well as from seed companies, seed dealers and seed outlets. Agricultural statistics, government production plans, commodity markets and prices, export and import offices, etc. may all be useful.

A complete profile of the typical farmers in the target area is required to answer some of the questions. Relevant information includes: the total cropped area, different crops planted (area coverage by each crop), different varieties used (area coverage by each variety and their performance), seed use (improved and local), planting rates, acceptable prices, desire for/acceptance of seed treatment, bag size, etc.

Provision of credit facilities

The competition in the target area must be carefully assessed and it is crucial to have a clear insight into the credit options available to the farmers, and to help customers get credit. The following questions related to needs for credit should be addressed:

- Does the planned seed enterprise require credit for customers?
- Would a credit programme be a good sales tool?
- Could the enterprise afford the costs and risks of offering credit?
- What type of credit programme (if any) should be offered?
- For how long the credit will be offered? At what interest rates?

The decisions on which crops and varieties to produce are based on the information collected from different sources. The best chances of success are usually provided if the market research is able to identify a unique 'market niche'. From the market research, initial sales volume (per year/per target area by crop and variety) will be estimated, and promotional efforts will be required to achieve the marketing targets.

Moreover, the plan should also look into the marketing channels envisaged for the business. Accordingly the following questions need to be answered:

- Will the enterprise market seeds from its primary business site only?
- Will it own its retail stores/outlets?
- Will it use others retail stores/outlets?
- Will the enterprise market its goods through contracted or independent salesmen?
- Will it work with its own or with third party distributors?
- Will it work through wholesale companies owned by the company or by others?

The results of the survey addressing these topics are summarized in the marketing section of the business plan. If the planned seed business will deal with other agricultural inputs, a similar analysis should be made for them.

Financial plan

The financial requirements of a seed enterprise are estimated by determining the financial resources required and the operating costs involved. This includes estimating needs for starting up and for future operations and/or expansion. Also, since sales determine gross income, a careful analysis must be made to determine if the potential sales can generate the income and profit required for the enterprise to stay in business.

The expenses incurred to set up an enterprise are called '*start-up costs*'. These can be major expenses and may include: deposits, licenses and permits, legal and professional fees, insurances and advertising costs. These costs must all be financed before the enterprise is even established and starts to generate any income. There must still be enough funds left to pay for operations for the initial period before income reaches the point where it can cover costs.

Other financial inputs are the capital costs, overhead costs and operating costs. *Capital costs* include costs of land, building, seed cleaning equipment, seed storage structures, office equipment and other basic assets. *Overhead costs* consist of items that cannot be directly charged to the product. These include 'front office' executive costs (public relations; salaries for officers, secretarial staff, and supervisors), power, depreciation, and marketing expenses (promotion, transportation, storage). Overhead costs can be subdivided into fixed and variable overhead costs. *Operating costs* include the funds required for day-to-day operations such as costs of raw seed purchase, inventory, wages and salaries, supplies, maintenance, fuel, power, utilities, telephone, delivery/transportation, credit facilities, guarantees, after-sale services, etc. These include the variable overhead costs, but not the fixed overheads.

Seed costing

Cost accounting is prepared to calculate the cost of each kind of seed and arrive at a total cost of production. The costs can be fixed or variable. Fixed costs include: travel expenses, vehicle expenses, salaries and wages, depreciation, electricity, insurance, and repairs and maintenance. Variable costs include the costs of source seed, seed growers' premiums, fertilizers and chemicals, harvest expenses, seed transportation, processing and treatment, costs of bags and certification. Seed marketing costs, administrative and financial expenses must be included. The gross total costs is then divided by the total quantity of seed produced to arrive at the cost of seed per unit produced.

Seed pricing

In a successful seed enterprise, revenues from seed sales and other services will cover costs and allow for a profit. The price of seed is influenced by a number of non-cost factors, including the degree of competition, the purchasing power of the customers, the elasticity of supply and demand, and general economic conditions. When setting the seed prices, the enterprise needs to consider various points. Should it offer discounts for quantity purchases, or to special groups? What are the enterprise's expectations for the gross margin, and what are then the implications for the seed prices? Which varieties are slow and fast movers? Which varieties are price-sensitive for costumers? Is the enterprise going to consider restrictions regarding prices it can charge?

Income and profit

To manage an enterprise profitably, records must be kept and permanently analysed and evaluated. Basic records include: cash receipts, cash disbursements, cash sales, cash purchases, payroll, equipment inventory, credit sales, credit purchases and petty

cash funds. Only with such financial management, can the actual income and profits be made visible.

Most small seed enterprises may not obtain their revenue from seed sales alone; they usually add to their income by selling other farm inputs such as fertilizers, agrochemicals (herbicides, insecticides and fungicides) and/or small farm equipment. An additional income can also be derived from the sale of waste products as feed, or the sale of other crop products.

The market analysis determines the amount of seed (and other products) that can be sold. These amounts and the estimated sales prices (based on a market analysis, seed costing and seed pricing) will determine the gross income. The next step is to carry out a 'break-even analysis' and a 'what if' analysis. A 'break even analysis' will determine when the income from sales equals the cost. From that point onward profits will be made. A 'what if' analysis determines what happens under 'worst case' scenarios and 'best case' scenarios at various levels.

Figure 5.4 Example of a break-even chart for the establishment of a small-scale seed enterprise

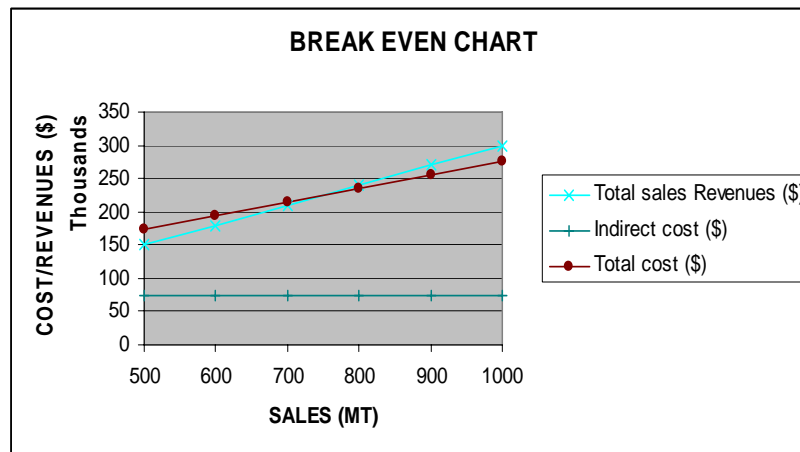

A simple approach to a break-even analysis is to construct a 'break-even' chart (Figure 5.4). Two lines are plotted; the first line shows total expenses incurred in producing/selling different quantities of seed/goods, and a second line shows the income received from selling each of these different quantities of seed/goods. Fixed costs normally remain the same, and can be plotted as a straight line on the break-even chart. However, variable costs will increase with increasing quantities sold. Total costs are the amounts plotted in the cost line. As sales quantities increase, the total income increases; this amount is plotted in the income line. The break-even sales are 750 MT in the example of Figure 5.4. For a small-to-medium-size new seed enterprise, even in a developed agricultural economy, it usually takes three to five years to develop enough market and customers to break even and start to make a profit. If a strong farmer demand already exists the break-even point can be reached within a shorter time period.

A 'reasonable' return is one that takes into consideration the amount of risk taken relative to an investment. For example, a low risk investment may yield 6% while a high risk investment generates a 'reasonable' return of 20%. As risk increases, so should the rate of return. For a seed enterprise, the return should be somewhere between these figures, depending on the crops and the environment the enterprise operates in.

Seed enterprise as legal entity

A seed enterprise is a legal entity and has specific legal liabilities and responsibilities. Depending on the country, certain legislative requirements must be met, which may include registration of the business, a business permit, legal incorporation, (governmental approval, and other permits (buildings, employment, etc.). Most countries have several legally-defined structures for enterprises, usually outlined in the 'Company Law'. Before starting the enterprise, it needs to be clear what licenses, permits and inspections are required. The business law applicable to the small-scale enterprise needs to be identified, as they often vary for micro, medium or for example cooperative enterprises. The enterprise needs to know the relevant safety and health requirements. And, like any company, it needs to comply with local ordinances on signs, waste removal, buildings, operating conditions, and with state tax and social security provisions. The legal form of a seed enterprise determines how it manages and conducts business, borrows money, and generates or disseminates financial information. Four legal frameworks exist for private persons who wish to initiate a business for profit. They are the following: sole proprietorship, partnership, limited liability company, and cooperative.

Sole proprietor

A business in the form of a sole proprietor is the most common form when a new small seed enterprise is started. The owner is fully and entirely responsible for successes (profit) and failures (losses). If the business fails, the owner is personally responsible for paying the debts, even if this means selling his personal assets. The owner may decide to manage his/her business or to employ people to do so, but they will remain employees and will have no final authority and responsibility. The owner may operate under his/her own or a business name. The name usually does not have to be registered with the agency implementing the law. If a business name is used, the owner's name should appear on all letterheads, etc. A sole proprietor has few legal requirements to fulfil. Generally, taxes are paid only on profit. There is no legal requirement to produce a financial statement showing profit. If the value of taxable assets and goods (per annum) is over a certain sum, the enterprise must be registered with the tax authorities and it is a legal requirement to maintain accurate records.

Partnership

A 'partnership' is when two or more people conduct a joint business. The number of partners should not exceed 20, but this depends on national legislation. The partners are all part-owners of the enterprise, and they jointly make decisions on its running. Alternatively, they may appoint one partner, or hire another person, as the manager.

They may operate under a business name, which does not have to be registered. Partners normally have an attorney-at-law draw up a legal agreement (contract) showing the proportions in which they share profit or loss, and other aspects of their operations. This agreement is the basis for the partnership. A 'Partnership Act' often specifies the conditions for setting up an enterprise with this legal framework. The enterprise should keep proper accounting records; capital must be distinguished from profits and losses; and records must be kept of profits, shares and withdrawals. The enterprise must provide all partners or their legal representatives with true accounts and full information of all operations affecting the partnership. The voting rights of each partner are equal to the amount invested. Partners are responsible for the debts of the business. If one partner fails to honour his or her obligations, the remaining partners are liable for all debts collectively. Requirements of tax and financial statements for partnerships are similar to those for sole proprietors. It is often easier for a partnership to raise funds, because there is less risk for the investor, as all partners share the investment. At the same time, all partners share any profit or loss.

Limited liability company

Unlike a 'sole proprietor' or 'partnership', a 'limited liability company' is a legal entity. The company is responsible for debts (liabilities) it incurs. If the company is unable to pay its debts, it can be sued, but the owners are responsible only up to the amount of money they invested in the company and personal assets are not subject to takeover. If the company is unable to pay its debts, it may go into liquidation. Shareholders and directors may change, but the company continues to exist until it is legally disbanded. Each year, a 'limited liability company' must provide certain financial information to all shareholders and to the government's Registrar of Companies. These data become public documents. The legal reporting requirements are complex and vary according to the type of company and its size. At the end of each financial year, accounts must be prepared, which include a profit and loss account, a balance sheet, an auditor's report, and a director's report.

Cooperative

A 'cooperative' is a specialized form of 'limited liability company' and is operated and managed in the same manner as any other small business with managers or supervisors. However, the difference is that the enterprise is owned by everyone who works in it, and decisions are made democratically and collectively. The same laws and regulations as for a 'limited liability company' apply to cooperatives. However, different mechanisms may apply to access to credit, favouring cooperatives because of their *cooperative* nature.

Organization of the enterprise

The success of any enterprise is determined largely by its internal structure and the relationship it has with relevant institutions and customers. Businesses with low turnovers depend mainly on close and trusting relationships with their customers. Small-scale enterprises that produce and sell quality seed in rural farming communities belong to this category. Key organizational issues relate to the

effectiveness of the operations supported by its management in achieving its objectives, and whether operations are efficient in terms of costs and time. Another important organizational issue is whether jobs within the enterprise are well described, and mandates and responsibilities are clearly stated. Another critical issue which is often overseen when new small enterprises are established relates to programmes for motivating and training employees.

Experience has shown that the most efficient organizational structure for a seed enterprise is based on the category of work. All work of a similar kind is organized into a single unit, so that a single manager can direct and coordinate all related activities so they are completed efficiently. In a small enterprise, all the operations can be carried out by no more than a couple of people, as long as they must have a broad knowledge of all the operations and the activities they entail. The organizational structure should be simple, and the small size and structure will enable direct supervision and intervention, quick decision-making and flexibility without reference to a long chain of command. A manager, who is at the same time a production officer, financial officer, and marketing officer would be the bare minimum for an enterprise which is involved in seed sales, but which does not have its own production, processing and quality control operations. A simple organizational structure for a small enterprise managed by three individuals is illustrated in Figure 5.5, where the enterprise is managed by the owner or manager and two assistants.

Figure 5.5 Organizational structure of a small seed enterprise

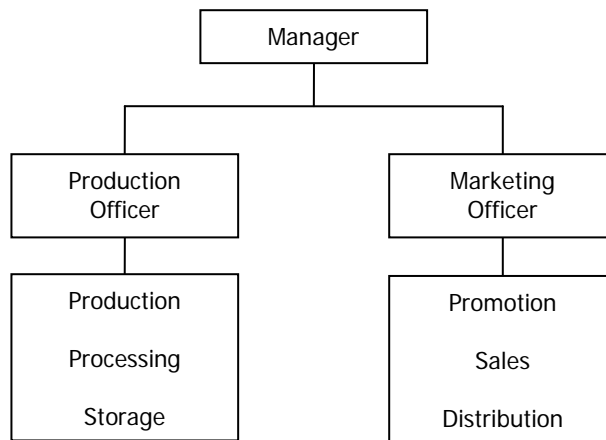

In slightly larger companies, a manager, a quality control officer, a processing and production officer and a marketing officer are usually required. Finance and personnel can often be combined as sections in a single administrative unit. Staff for branch offices (if any) may include a sales person/manager, permanent labourer/stock handler and daily labour. In large companies, several sub-divisions or sub-units may be organized under each of the major units.

Concluding remarks

This section has provided a guide to the most important aspects to be addressed when establishing a small-scale seed enterprise. A successful seed enterprise requires entrepreneurship and manages the physical, financial and human resources to carry out operations efficiently and make a profit. To ensure success, every business start-up must be preceded by an intensive, detailed analysis of its feasibility. A business plan is a detailed study of all the factors which affect the planned business; it assesses the potential, strengths, weaknesses, risks and profitability of the business in different market situations. To establish a viable business, a medium to long term strategy is required. The business plan provides insight into the enterprise's viability and guides the owner(s), groups of farmers and/or development agency supporting its set-up with answers to the many important questions mentioned in this section. When planning the development of small-scale enterprises that will work with groups of smallholder farmers, the resources required for investment and the need for capacity development should be considered, as these points are often overlooked when this business model is adopted, and there is external funding. At the same time, investment in small-scale enterprises should be on credit or on a sound financial basis, to stimulate the establishment of enterprises that are market-led instead of project-run, thus ensuring a viable and independent future.

5.3 Village-based seed enterprises in Afghanistan

*Zewdie Bishaw, Anthony J.G. van Gastel, Abdoul Aziz Niane
and Koffi Amegbeto*

Village-Based Seed Enterprises (VBSEs) are farmer-based seed production and marketing schemes operating at local level to ensure availability and access to varieties and seeds by farmers in less favourable environments and remote areas. The VBSEs are of a participatory nature: they mobilize and involve small farmers in target environments. They multiply well-adapted and farmer-preferred varieties at local levels. The production is market oriented, as it is linked to seed demand from local and nearby communities. Because of this, costs for local production, transport, marketing and distribution are low, and seed prices can be kept down. The quality of the seed produced meets relevant quality standards, which are those appropriate to farmer requirements, and does not necessarily meet formal standards. Appropriate low-cost cleaning and treatment technology is used for production, processing and storage, resulting in improved seed quality. The schemes are considered to contribute to a sustainable seed supply by improving availability and access. This is ensured through farmers' empowerment and their proper ownership of seed businesses. And lastly, the VBSEs are targeted to evolve to small, privately owned small- to medium-scale seed enterprises. This section provides some insight into VBSEs as an alternative seed delivery system and shares some information based on their implementation in Afghanistan.

Elements in the success of village-based seed enterprises

There are a number of prerequisites for the establishment and successful operation of VBSEs. The first prerequisite is a regular demand for seed among farmers within the community, neighbouring villages or districts. The second is a reasonable price, i.e. seed should be both affordable for farmers and profitable for producers. The third is an appropriate seed quality: the quality of marketed seed should be consistently higher than that of farm-saved or locally exchanged seed. Fourthly, farmers should take responsibility for managing and operating the enterprises. And lastly, in order to do this, they need support in working with tailor-made business plans, based on demand analysis and developed during appropriate training.

Steps for establishing village-based seed enterprises

The approach to initiatives involving farmers is often top-down, based on the assumptions of development agencies rather than critical appraisal of existing situations on the ground. A number of steps to be followed for the successful establishment of a VBSE are given below. The steps are also presented in Figure 5.6.

Figure 5.6 Steps in establishing village-based seed enterprises¹³⁷

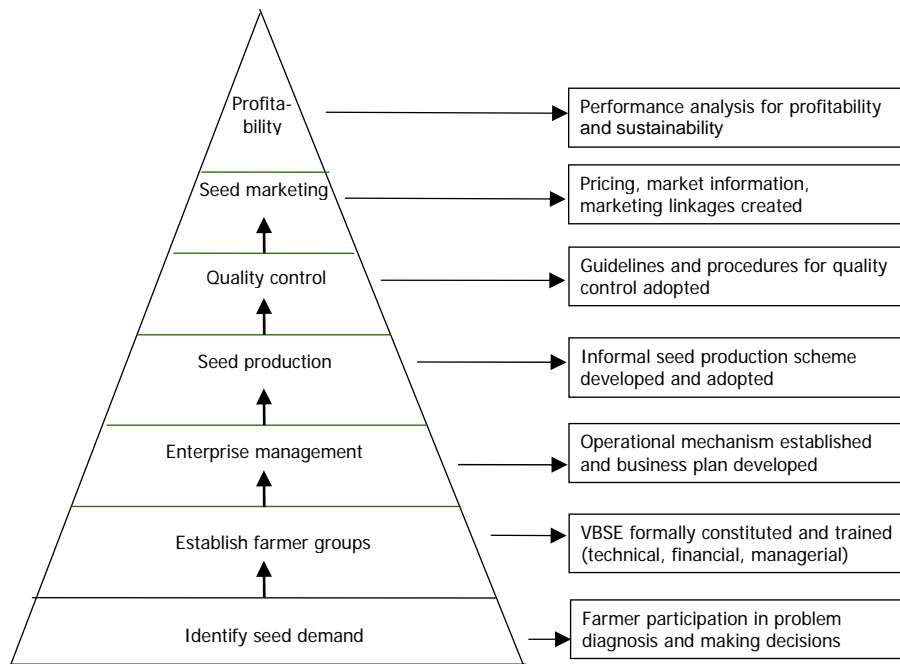

During the seed system analysis, the seed demand or 'seed gap' is assessed. Stakeholders are consulted to identify who might have an interest in and would support VBSEs, and to build a consensus and determine roles and responsibilities in supporting operations and implementations. Participating farmers must be interested in setting up seed production and marketing enterprises as alternatives to grain production. The farmers take responsibility and leadership and elect their own leaders,

while the partners facilitate, provide guidance and advice. Farmers should be selected on the basis of the following criteria: reputation in the community, experience in farming and seed production, relatively bigger/better land holdings, possession of equipment, entrepreneurial skills and financial resources. The land selected should be suitable for quality seed production, i.e. fertile soils, reliable rainfall (or irrigation), low incidence of diseases, pests and parasitic weeds, proximity and accessibility to main roads/facilities. The business plan serves as a guide to strategic planning and assesses all the factors which may affect the enterprise: business potential, strengths, weaknesses, risks, products (crops, varieties), potential markets, costs, sales and potential profits. It also includes risk assessments and sets out details of ownership, management and legal structure, staff, equipment, and the budget. All seed production and marketing operations are carried out by the members of the VBSE. Promotional efforts and marketing are the final prerequisite to ensure success.

Creating linkages and supporting village-based seed enterprises

The strategy of involving stakeholders and encouraging them to work towards an annual business plan based on demand-led production is critical to the development of sustainable, financially profitable seed production and marketing enterprises. Key aspects of partner support are described in Table 5.1. Partners help VBSEs to source early generation seed of the varieties most adapted to their areas from NARS (conventional or participatory breeding programs). Similarly, partners assist VBSEs to source the inputs (such as fertilizers and pesticides) required for quality seed production. Partners provide training, guidance and assistance, to ensure that VBSE members have the skills and knowledge necessary to produce seed that meets quality standards. Partners also help VBSEs to acquire simple low-cost mobile cleaner and treatment prototypes which can then be easily copied and modified locally, and to build appropriate central seed storage facilities. Partners train VBSE members to carry out field inspections and simple seed quality tests, or provide these services through the formal sector. The marketing strategy includes promotional activities through on-farm demonstrations of new varieties, field days for neighbouring farmers held during the cropping season, or market information provided through ministries, extension services, and NGOs. VBSEs need access to credit for purchasing field equipment, inputs (e.g. source seed, fertilizers and pesticides) and seed-handling equipment (e.g. for cleaning, treatment, and packaging). Farmers require step-by-step training in technical skills (for planting, harvesting, cleaning, treatment, testing and storage), financial and enterprise management skills (for the day-to-day operation of seed enterprises, record keeping, developing business plans). VBSEs are assisted in establishing a network to link up with input providers, and facilitate information exchange and sharing of experiences. Linkages between grain producers and local agro-processing industries stimulate the use of better technology, creating demand for the use of quality seed. A detailed work plan and timetable should be developed for the implementation of VBSEs. The commitment of all partners to the work plan and timetable will ensure timely and successful execution.

Performance of village-based seed enterprises

VBSE programmes are operational in countries like Afghanistan, Algeria, Morocco, Pakistan, and Tunisia where they have received support through various stakeholders supported by the Seed Unit of the International Centre for Agriculture in Dry Areas (ICARDA). Supported through this unit, they may further expand to Ethiopia, Eritrea, Syria and Yemen. In Afghanistan, under the Rehabilitation of Agricultural Markets Programme (RAMP), 21 VBSEs were established in five target provinces from 2004 to 2006. Each VBSE was allocated, on average, more than 20 ha of land and produced over 100 tons of quality seed of four strategic food crops (wheat, rice, mung bean and potato) for income diversification (Table 5.2). An assessment of seed production capacity and profitability demonstrated a total net income of US\$ 0.85 million for 17 VBSEs in 2004/05 (Table 5.3) and US\$ 2.3 millions for the 21 VBSEs in 2005/06 (data not shown), through production and marketing of quality seed.

Table 5.1 Major stakeholder institutions supporting village-based seed enterprises and suggested responsibilities

<i>Institution</i>	<i>Major responsibilities and activities</i>
Ministry of Agriculture – policy departments	<ul style="list-style-type: none"> • Adopt VBSEs as alternative seed delivery system • Identify national focal point for implementing VBSEs
Ministry of Agriculture – extension departments	<ul style="list-style-type: none"> • Identify target areas for VBSEs • Identify and assist farmers to establish VBSEs • Help farmers to (i) identify production sites and (ii) start seed production (field selection, planting) • Monitor seed production (cultural practices, harvesting, cleaning, storage, internal quality assurance) and provide advice • Assist VBSEs in promoting and market seed • Build capacity of farmers and stakeholders
Input suppliers	<ul style="list-style-type: none"> • Assist VBSEs in sourcing agricultural inputs
Agricultural Research Institutes	<ul style="list-style-type: none"> • Identify/develop suitable adapted local/improved varieties • Provide source seed for multiplication to VBSEs at a reasonable price • Capacity building in crop production
Public seed producing agency	<ul style="list-style-type: none"> • Provide source seed for multiplication to VBSEs at a reasonable price • Build capacity in seed production, financial and enterprise management
Public certification agency	<ul style="list-style-type: none"> • Provide quality assurance (not control) and assist VBSEs in internal quality control
Banks, cooperatives	<ul style="list-style-type: none"> • Provide credit for equipment and working capital
NGOs, local seed traders	<ul style="list-style-type: none"> • Empower farmers • Assist in promotion and seed marketing • Assist in sales and distribution of seed
International agricultural research centres – seed unit	<ul style="list-style-type: none"> • Build capacity of stakeholders and farmers • Provide seed cleaning equipment • Technical backstopping of VBSEs (demand assessment survey, business plan) • Analyse profitability for upscaling, out-scaling based on lessons learnt

Table 5.2 Amount (in tons) of seed produced and marketed by VBSEs from 2004-2006 in Afghanistan

<i>Crop year</i>	<i>Active VBSEs</i>	<i>Wheat</i>	<i>Rice</i>	<i>Potato</i>	<i>Mung bean</i>
2003 /04	6	753	525	-	-
2004 /05	17	2188	651	752	325
2005 /06	21	3,533	2,352	3,784	186

Table 5.3 Area cultivated, seed production and revenues by VBSEs in Afghanistan in 2004-2005

<i>Item</i>	<i>Wheat</i>	<i>Potato</i>	<i>Rice</i>	<i>Mung bean</i>
Number of active VBSEs	17	14	9	7
Total area (ha)	542	45	139	264
Average area (ha /VBSE)	32	3	15	38
Total production (t)	2,188	752	651	325
Average production (t/VBSE)	129	54	72	46
Average production (t/ha)	4.04	16.7	4.7	1.2 3
Average price (farm gate Afs/t)	17,000	8,946	17,460	21,300
Gross revenues (Afs/ha)	68,680	149398	82062	26,199
Production cost (average Afs /ha)	20,205	51,000	31,190	9,025
Net average marginal income (Afs /ha)	48,475	98,398	50,872	17,174
% Marginal income	239	193	163	190

Source: ICARDA Seed Unit Annual Report 2004-05.

Concluding remarks

Farmer groups, communities, NGOs, and other organizations undertake different types of local level seed production, operating largely through external donor support, which tends to encourage 'dependency' and show little concern for sustainability. Based on the performance of various informal local seed supply initiatives, the approach presented in this section recommends the formation of business-oriented small-scale village-based seed enterprises (VBSEs) which encourage long-term sustainability. For VBSEs to succeed, they must have appropriate linkages with formal sector institutions such as agricultural research, seed production units, financial services and extension services. VBSEs can also promote the adoption and diffusion of modern crop varieties and associated technologies, by taking seed to remote regions and less favourable environments where farms are small and farmers are resource-poor. VBSE members need to be trained in seed production technologies, and financial and business management. They also need the freedom to operate informally, without the need to comply strictly with the stringent requirements of the regulatory and quality assurance agencies of the formal sector. The concept of organizing village-based low-cost production and marketing seed enterprises to optimize seed delivery and diffusion of new varieties as an alternative to formal seed systems that is also complementary to them has proven feasible and effective for reaching poor farmers in marginal areas where the formal public and private sectors are not supplying quality seed.

5.4 Farmer seed enterprises in Uganda *

Soniia David

In developing countries, public and private seed companies supply no more than 20% of seed of most food crops. They produce certified seed in centralized facilities. This figure is even lower for self-pollinating crops (e.g., the common bean, groundnuts, rice), vegetatively propagated crops (e.g., potatoes, cassava), and crops with limited seed demand (e.g., indigenous vegetables, forages). Crops in these categories bring little profit to seed companies for several reasons: uncertain and fluctuating demand caused by competition from farm-saved seed (grain legumes), low multiplication rates (grain legumes), transportation and storage difficulties (soybean, root, and tuber crops), and strong regionally specific preferences (grain legumes, indigenous vegetables). Designing alternative seed delivery systems must therefore be given urgent priority.

Recent years have witnessed a proliferation of NGO and research support to local level seed production and dissemination activities. These activities have a wide range of objectives, including preserving genetic diversity, improving dissemination of modern varieties, improving seed availability (time, place, quantity), and reducing seed cost and dependence on external sources. Typically, in Africa, local level seed production projects can be grouped into three categories: (a) seed production using contract growers, (b) seed exchange schemes, and (c) farmer seed enterprises.¹³ The last approach, being commercially oriented, appears to be the most sustainable.

Farmer Seed Enterprises (FSEs) offer four main advantages over other approaches: (i) sustainability, by being market driven; (ii) decentralization of seed production to cater for regionally specific varietal preferences; (iii) possibilities for establishing linkages to formal institutions, and (iv) production of good quality seed - an issue of concern in areas of high disease pressure. Studies to evaluate the success of commercial seed production by small-scale farmers conclude on the basis of existing projects that this approach is unlikely to be sustainable.¹³⁸ Reasons for failure include poor project design (unclear objectives, failure to build in sustainability), lack of technical expertise and institutional linkages to research and seed agencies, and lack of attention to marketing. This section reports on experiences by the International Centre for Tropical Agriculture (CIAT) with developing farmer seed enterprises (FSEs) in Africa and Uganda in particular. Commercial seed production by farmers is proposed as a strategy for meeting dual objectives: to distribute and promote modern crop varieties and to establish a regular source of 'clean' seed of either local or modern varieties. Secondary goals of this approach might include preserving varietal diversity through multiplying landraces, generating income, and farmer empowerment. The section is about working with beans, but most of the principles and guidelines offered

* This section is a summarized version of a paper published by Soniia David in 2004 *Agriculture and Human Values* 21: 387-397; reprinted with kind permission from Springer Science and Business Media.

can be applied to developing farmer capacity to produce seed of other self-pollinating crops.

Initiating farmer seed enterprises

Three farmer groups in Eastern Uganda participated in the study between 1994 and 1997. These were the Ikulwe Bean Farmers' Association (IBFA), which is a mixed group of men and women located in Iganga District; the Makhai Women's Group (MWG) and the Budama Kyelema Turbana Women's Group (BKTWG) in Mbale District (Table 5.4). Although the project was undertaken with farmer groups rather than individuals, this was only intentional in Mbale, where the objective was to investigate the feasibility of women's participation in small-scale commercial seed production. By local standards, group members were average or above average in terms of resources, skills, educational level, and prior business experience (Table 5.4).

Table 5.4 Characteristics of bean seed enterprises, Uganda

	<i>IBFA</i>	<i>MWG</i>	<i>BKTWG</i>
Sex of members	Men and women	Women	Women
Year established	1993	1990	1994
Original membership	10 households	10 women	12 women
Percent of members in average and poor wealth categories ¹	87	50	62
Percent of members with upper primary and above education	80	90	54
Activities prior to seed production	None	Sale of food crops	Sale of food crops, piggery
Prior contact with external agencies	High	High	Low

Note: ¹Wealth classification of group members is based on wealth ranking exercises conducted with key informants

Identifying study sites and producers

Level of demand for bean seed was the single most important criterion in selecting study sites. In all localities, beans are grown during two seasons: March-May (season A) and September-November (season B). Production during season B is riskier because of heavy and unpredictable rainfall. Mbale represents an area of high demand for bean seed, with demand being typically lower in Iganga District. The major criteria used in group selection were the following: membership (10+), few or no other group activities, and previous business experience. Except for the IBFA, whose activities predated the study, seed production activities began with a five-day training workshop covering the following: disease and pest identification and management, agronomic practices for seed production, post-harvest handling of seed, testing germination and moisture content using simple methods, marketing and promotion, book keeping, costing, and group dynamics. Training workshops were held again in 1997 and additional training was offered on an ad hoc basis on disease and pest identification and management and business skills.

Groups were provided with three pieces of equipment: a threshing rack to minimize loss and mechanical damage to the seed, a sorter to facilitate the work and allow sorting to be done while seated, and black polythene sheets for drying. The fields of seed producers were not inspected, but seed health testing was conducted over three seasons (incomplete for some groups) to assess pathogen infection levels and germination.

Producers multiplied two bean cultivars released in 1994: K132 and K131. Farmers throughout Uganda highly appreciate K132, a large, red mottled seed type, because of its close resemblance to the widely grown, highly marketable K20 variety. On-station yields for K132 range between 500-1500 kg/ha, 27% above the yields of K20. The variety is susceptible to two seed-borne diseases: *pythium* root rot and common bacterial blight (CBB). K131, a small, beige seed type previously unknown in Uganda, is high yielding (1200-2500 kg/ha or 40% above the yields of K20), but its small size, type II growth habit, and low market demand make it less popular with farmers. This variety is resistant to the bean common mosaic virus (BCMV) but susceptible to angular leaf spot (ALS). Although producers were encouraged to multiply seed of local varieties, they showed little interest because of the low productivity of landraces and an anticipated low demand.

A participatory approach was used in training and in all aspects of developing FSEs. The role of researchers was to facilitate the learning process and to support and encourage farmers' decision-making, problem solving, and empowerment. Producers made all decisions, including which varieties to multiply. A second element of farmer participation was the focus on farmers' indigenous knowledge of bean diseases and pests. Because their knowledge was limited, farmers were encouraged to coin names for major diseases and pests. To minimize the farmers' risk-taking, emphasize ownership of the business, and avoid creating a dependency mentality, equipment and seed were provided on the basis of cost sharing between farmers and the CIAT. No form of financial assistance was provided because of the absence of suitable NGO partners who could administer loans.

Researchers visited the groups at least once each season to monitor and plan activities and discuss problems. Extension agents visited the groups more frequently, particularly during field operations, to offer technical advice and collect data. An evaluation of the impact among producers was conducted in 1997 by MWG and BKTWG, and facilitated by an extension officer.

The three FSEs differed with respect to resources such as education, access to land and labour, prior training, group cohesion, business experience, and mode of organizing production and distributing assets, all of which affected their achievements. For example, the dynamism of the MWG in selling and promoting their seed may be attributed to the higher educational levels of its membership, previous training from an NGO in group dynamics and bookkeeping, stronger group cohesion fostered by that training, and the group's longer history. It is probably no coincidence that the BKTWG, a more recently formed group with no prior contact with external agencies, experienced a high drop-out rate and made little effort to market and promote their seed.

Production was organized on either a communal or an individual basis. From 1993B to 1994B, members of the IBFA planted seed on a communal plot but shifted to individual production in 1995A because motivation was lacking for communal work and land rental costs were high. Individual growers were responsible for post-harvest tasks. A committee of members conducted inspections of individual fields to check for off-types and diseases. Growers were expected to return all seed produced to the group for storage and marketing and received 25% of the earnings thereof.

Both Mbale groups grew seed on a communal plot (borrowed or rented from neighbours) where all members were required to contribute labour. The Mbale groups hired oxen for land preparation, which delayed planting at least once. Both the MWG and the BKTWG sprayed the crop against insect pests, a task the IBFA omitted. No group used fertilizer or other soil improvement measures. All producers tested the germination and moisture content of the seed before storage and treated it with Actellic (pirimiphos-methyl) to control storage pests. Seed was bagged and labelled (in some instances) using locally purchased plastic bags. In all cases, group members exclusively provided labour for all activities. The IBFA and MWG retained group funds, which, in the latter case, were available as credit to members. The IBFA was the only group to open a bank account.

Seed production and quality

Seed production and productivity by all three enterprises was disappointingly low: IBFA produced the most seed (2561 kg over seven seasons) followed by BKTWG (535 kg) and MWG (478 kg), each over four seasons (Table 5.5). Yields per unit area and multiplication rates were modest for sole cropping. Both cultivars out-yielded K20: K132 by 34% and K131 by 14%.

Table 5.5 Clean seed produced (kgs) by farmer seed enterprises, Uganda, 1994-1996

	<i>Season</i>						<i>Total</i>
	<i>1994A</i>	<i>1994B</i>	<i>1995A</i>	<i>1995B</i>	<i>1996A</i>	<i>1996B</i>	
K 132							
• IBFA	90	50	117	123	105	195	680
• MWG	Na	Na	300	0	55	40	395
• BKTW	Na	Na	240	83	40	95	458
G							
K131							
• IBFA	550	120	536	470	170	35	1881
• MWG	Na	Na	10	60	13	0	83
• BKTW	Na	Na	67	0	10	0	77
G							

All producers sowed a larger total amount of K132 compared to K131, reflecting market demand. Fluctuations from season to season in the amount of seed sown by all groups did not necessarily reflect anticipated demand but resulted from personal mishaps such as illness. Only the IBFA pursued a strategy of planting larger quantities

in season B (1995/1996), anticipating higher demand for K132 in the following season A.

Economic analysis of production by the two Mbale groups during the first two seasons of production revealed four important findings (Table 5.6). First, labour constituted the highest single cost. Second, returns were better during season A because of lower yields in season B, attributed largely to agro-climatic factors. Third, except for MWG in the second season, the cost of seed production by FSEs is lower than that of on-station production (estimated at \$1 or Ush. 1000 per kilo). Fourth, judging from output-to-input ratios (excluding season B for MWG), both groups covered their production costs, showing that seed production by farmers is a potentially viable enterprise.

Table 5.6 Farmer enterprises seed production costs (Ush. per kg), Mbale, Uganda, 1995

	<i>Season A</i>		<i>Season B</i>	
	<i>MWG</i>	<i>BTWG</i>	<i>MWG</i>	<i>BTWG</i>
Inputs	64	88	218	146
Labour	211	249	1,058	392
Variable costs	275	337	1,276	537
Fixed costs	35,175	45,125	32,375	24,875
Gross value of output (Ush/acre)	217,000	223,273	42,000	66,400
Gross margin per unit of bean seed	491	493	418	365
Output-to-input ratio	1.80	1.50	0.39	0.96

Five factors account for the low yields of seed growers: adverse climatic conditions (drought, hailstorms, and heavy rains); high disease and pest incidence (CBB, ALS, root rots, various insect pests); poor cultural practices (poor land preparation, late planting, wide spacing); lack of access to resources such as land and oxen; and poor soils and/or low soil fertility. Although little can be done about unfavourable climatic conditions or the lack of resources by targeted groups, suitable interventions and criteria for selecting producers can alleviate the remaining production constraints. High seed loss caused by diseases suggests that, in the absence of fungicides, to achieve economic returns, FSEs should limit multiplication to resistant varieties and maintain good crop husbandry. Other suggestions for increasing seed production include targeting farmers with sufficient resources to hire labour and purchase oxen to alleviate labour bottlenecks, practicing crop rotation, and using fertilizer or other soil improvement substances (e.g., green manures). Poor cultural practices highlighted the need for closer supervision of field activities by technical support staff.

Farmers' poor cultural practices also underscored the conflict that smallholders, women in particular, experience between business and household or personal interests. Invariably, the members of the two women's groups tended to their household fields before the communal field, resulting in late planting and weeding. Because African women usually do not own land, have limited access to household labour, and experience difficulties in preventing male appropriation of their business

profits, communal seed growing and group activity appears to work best for them, despite several drawbacks (e.g., access to land and low motivation to contribute to group work).

The quality of seed produced by the three FSEs surpassed that of seed sold in nearby shops and markets in 1995A in terms of germination rate and disease levels. The germination rate for seed produced by the FSEs averaged between 85-94% compared to 72-74% for other commercial sources. A relatively low level of fungal bean pathogens was observed in samples from shops and markets located near FSEs (e.g., 1.8% for *Fusarium oxysporum f. sp. phaseoli*), but the level of infection in IBFA seed was negligible. Some samples from seed enterprises showed relatively high levels of saprophytic infection. The improved quality of FSE seed is attributed to the groups' use of better field and post-harvest practices and skills (i.e., roguing, drying, sorting, and seed treatment).

Seed marketing and promotion

Nearly all the seed produced by FSEs was sold locally, usually within two to six months after harvest for Ush. 600-1200 per kg. These prices are up to nearly twice the highest price of grain at planting time (Ush. 700), and comparable with, or higher than, the retail price of certified bean seed (Ush. 600-800 per kg). Sale prices, however, may express farmers' willingness to pay for new varieties as opposed to paying a premium for 'clean' seed. The quantities of seed purchased demonstrate the ability of FSEs to meet the specific needs of smallholders. More than 30% of Mbale buyers bought three or more kilos and most Iganga farmers purchased smaller amounts, confirming differences among districts in demand for seed. Because all transactions involved cash sales, FSEs do not appear to significantly facilitate the equitable spread of new varieties. All groups sold K132 faster than K131, but rejected the idea of charging a lower price for the latter variety to encourage sales.

Given fluctuating demand for seed, and in the absence of a specialized market for seed among Ugandan smallholders, seed entrepreneurs must actively engage in promotional and marketing activities. Although efforts in this area differed between groups, marketing was hardly ever a constraint, given the limited quantities of seed produced. Although agricultural input suppliers could provide a reliable market for farmer seed producers, in contrast to FSEs in Tanzania, all groups rejected this strategy because of the low price offered by stockists and traders. The MWG gained visibility by participating in the district agricultural show. The IBFA advertised its product at farmer meetings, through local authorities and traders, and sold seed through door-to-door canvassing to schools, a rural development project, the district agricultural office, and, on one occasion, to an NGO. Factors accounting for slower sales by IBFA and BTWG include the following: lower demand, limited promotional efforts, farmers' reluctance to buy K131 due to its small size and lack of market, high prices (IBFA), competition with free seed of the same varieties distributed by the Uganda National Bean Programme (IBFA), and farmers' tendency to confuse K132 with a local variety (IBFA).

Impact of seed enterprises

The impact of the three seed enterprises can be assessed at two levels: among producers and in the wider community. Seed production had a positive impact on the producers in the areas of financial improvement and empowerment. Earnings by the FSEs during the study period surpassed income from traditional income earning activities such as the sale of food crops: about US\$1700 for IBFA, US\$337 for BKTWG and US\$272 for MWG. The MWG also used seed sales to establish a loan fund for family emergencies. During a newspaper interview,* a member of the MWG reported that due to increased income from seed production, “I no longer have to wait for my husband to provide for everything. I clothe myself and also buy clothes for my seven children”.

Both women’s groups felt that they had satisfactorily achieved the objectives of the project, although compared with MWG, members of BTWG rated their achievements more modestly. Both groups realized the need to increase production. They appreciated the participatory approach used by researchers, noted members’ increased confidence as a valued output of being involved in seed production, but identified the need for more training.

Lack of business profitability and sustainability are a frequently cited weakness of local level seed production activities.¹¹ Follow-up of the groups after the end of the project in 1997 and community surveys conducted in 2001 indicate both positive and negative trends in business success and also show important differences between the two project sites. Both the IBFA and the MWG were still producing seed in 2001, six to eight years after they started, but the BKTWG had stopped. Although production figures are unavailable, anecdotal evidence suggests that the groups’ level of production and sales have not increased significantly over the years.

A 2001 survey of a small sample of randomly selected households in nearby villages showed significant differences between the two sites in awareness of the groups and the seed purchasing behaviour of local farmers. Sixty seven percent of 30 surveyed households had heard of MWG, while only 11% of 45 households had heard of IBFA. Twenty three percent of surveyed farmers had bought seed from MWG compared to 4% that had obtained seed from IBFA. Even in the absence of financial data from the groups, this evidence casts doubt as to whether sites with low production and therefore low seed demand, such as Iganga District, can support profitable seed enterprises. In 2000, in response to continued low demand from local farmers, IBFA began selling bean seed to the district farmers’ association and multiplying cassava planting material.

Significantly, in both sites, the majority of surveyed FSE customers were one-time buyers. This finding, the ability of MWG to sell seed to farmers from nearby areas and the spontaneous emergence of another seed production group in a district near MWG, are all indications that demand exists for new varieties but not necessarily for clean seed. This preliminary discussion of sustainability issues confirms that demand for seed is a serious constraint for small-scale seed businesses and suggests

* Article in the New Vision Newspaper, April 2000: “Blessed is the bean seed which feeds the Mahayi women’s group.”

that successful enterprise development requires specific market conditions and/or crop characteristics. Before FSEs are dismissed as unviable, there is a need for detailed and systematic investigations of well selected, well designed case studies involving different crops, to assess profitability and sustainability issues.

Lessons from the Ugandan case studies and future challenges

Research on modalities for developing farmer seed enterprises provided valuable lessons that are summarized below. The discussion also makes suggestions for scaling up this approach in Eastern and Southern Africa.

Organizational issues

The Ugandan experience shows that farmers can be trained, organized, and motivated to produce and market good quality bean seed. However, smallholders' capacity to produce seed efficiently and on a modest scale may be limited by their lack of resources (land, labour, time, and capital). Large-scale farmers may be more capable of achieving modest production levels (e.g., >1-2 tons of bean seed per year) and may be better placed to establish commercial contacts. FSEs may, therefore, not be appropriate for all crops that receive low priority from the formal seed sector, agro-climatic environments, or indeed, all dissemination objectives. Table 5.7 outlines major crop dissemination objectives and proposes other approaches.

Depending on various social considerations (such as trust and group dynamics), as well as financial and resource considerations, either individual farmers or groups can be involved in specialized seed production. Smallholders' production and motivation to produce are influenced by the mode of organizing seed growing (individually versus communally) and arrangements for remunerating individual growers. An arrangement that allows for individual production and collective post-harvest handling may be optimal from the production side, but for socio-economic reasons may be unsuitable for certain farmers. Women seed growers face specific production constraints because of their limited access to resources (land, labour, capital) and difficulties in controlling their own resources (labour, capital).

Repeated training on various aspects of seed production, agronomy, business skills, and marketing is the key to successful enterprise development. For effective training, the development of simple training materials for farmers is essential.^{139,140} To improve their crop management, seed producers may also require close and regular field supervision by technical support staff for an initial period.

Supporting seed production efforts by farmers requires technical and business-related expertise and enormous time investments for monitoring producers and developing institutions and institutional linkages. Because of the need for strong business-related skills and the initially high supervision costs, agricultural researchers may have difficulty in initiating this approach. Instead, interested NGOs should start programmes with technical support from agricultural researchers. The initial high transaction costs of such programs should pay off in the long-term, assuming that the system is sustainable.

Table 5.7 Strategies and guidelines for selecting varietal dissemination approaches

<i>Objective</i>	To initiate varietal dissemination and promotion	A non-market driven system for dissemination	A sustainable, market-driven system for dissemination
<i>Strategy</i>	Seed multiplication and marketing by formal institutions	Multiplication of grain by farmers working with formal institutions	Small FSEs ¹ Small seed companies Decentralized contract farming Micro FSEs ¹ Support for existing farmer seed entrepreneurs ²
<i>Where appropriate</i>	Project-driven, quick impact needed	Project-driven, quick impact needed Low/medium and irregular demand for seed	High and regular demand for seed Farmers willing to pay for premium seed High disease pressure
<i>Concerns</i>	Sustainability High establishment cost	Slow diffusion Sustainability	External intervention needed High establishment cost Requires farmers with adequate resources Technical supervision required Sustainability Economic viability questionable

Notes: ¹ The difference between micro and small FSEs is the scale of production which is related to the scale of demand for seed and the resources available to the producers.

² In some settings, some farmers specialize in seed production and may be known as seed 'experts' by their community.

The bean case shows that although local demand exists for seed of new varieties produced by specialized producers, creating long-term, continued demand for good quality seed for certain commodities is more problematic. To achieve both objectives, FSEs must devise proactive marketing and promotion strategies aimed at larger markets to ensure long-term business success. An issue related to demand is price. For some crops, such as beans, seed producers may find it difficult to sell seed at a high enough price to cover production costs. The reasons are twofold in the case of beans. First, farmers cannot easily distinguish between seed and grain. Second, they are not aware of the importance of seed quality, or of many of its aspects, and thus are unwilling to pay a premium. Customers of Ugandan FSEs mentioned germination, physical cleanliness, and large seed size as advantages of purchased seed but did not attach direct importance to disease-related aspects. Education efforts by specialized producers and formal institutions (government agencies, NGOs, etc.) might help to create a better awareness and appreciation of good quality seed.

Scaling up

Promoting farmer-led seed production activities is challenging and no single approach or model exists for success. Key elements needed to ensure the successful development of FSEs include: (i) a steady supply of a range of superior varieties (from farmers' perspective), which requires several years of strong institutional support to develop farmer capacity for seed production, small enterprise development, and establish a sustainable system for supplying source seed; (ii) a flexible quality control system; and (iii) formal institutional linkages to insure the success of both these initiatives.

Avoiding the documented pitfalls of NGO involvement in seed production poses serious challenges to all agencies concerned with varietal promotion and seed production. Other commercial decentralized approaches, such as contract farming involving a partnership among traders, stockists, or seed merchants, and farmers, or seed production by institutions, such as schools and churches, have only recently been initiated in Eastern and Southern Africa. National and international research institutions can play both a catalyzing and a technical role. For example, they could help other agencies to design sustainable programs, establishing informal national level bodies to bring together agencies involved in community-level seed activities to avoid duplicating efforts, to facilitate networking, to coordinate nation-wide activities, and to lobby for policy reforms.

Conclusion

The experiences with FSEs in Uganda confirmed that small-scale African farmers can be organized and motivated to produce and sell good quality bean seed. However, because of the pilot nature of the project, many of the problems encountered could not be resolved. Nevertheless, the study provided valuable guidelines and lessons for future initiatives. While FSEs offer a potentially sustainable solution to the problem of seed supply, the challenge of implementing this approach in Eastern and Southern Africa remains formidable. Collaborative linkages need to be fostered among farmers, researchers, agro-enterprise specialists, NGOs, and the formal seed industry. Seed policy reforms need implementing and more client-oriented research systems must be institutionalized.

As the model proposed here suggests, FSEs must be developed within the context of an integrated seed supply system. This runs the spectrum from unspecialized seed production at the farm level to the formal seed industry, with each element playing well defined, sometimes overlapping, roles. Guidelines offered in this section need to be tested and new approaches devised in line with national conditions. It remains to be seen whether farmer-led seed provision systems can provide the impetus for revolutionizing national breeding procedures, varietal testing and release systems, and seed policy.

5.5 Small-scale farmers' rice seed enterprises in Bangladesh

Heleen Bos, Conny Almekinders and Kazi Borhan Amin Raj

This section deals with the establishment of small-scale farmer enterprises that produce and commercialize rice seed in the main rice-producing areas of Bangladesh. The strategy is described and the main factors contributing to the success of the initiative are analysed. The initiative is not the only one to have addressed farmer-based seed production in Bangladesh since a favourable national seed policy was established. However, it looks as though it has been a particularly successful one: not only are the first farmer enterprises established still 'in business', but its model of farmer seed enterprises has also been adopted by many farmer groups and NGOs.

Background

Rice is the main staple food crop in Bangladesh. It is grown in two seasons per year: rain-fed low-land rice is grown in the 'Aman' season, and dry season irrigated rice in the 'Boro' season. Typically, a farmer plants a total of 0.2 ha of land (either owned, share cropped or tenure) and 80-100% of this is rice. Rice is both a commercial and subsistence food crop. The market price fluctuates over the years, but in general remains well above the production costs.

The majority of the farmers rely on own farm-saved seed for sowing the next rice crop for various reasons. It is allowed in Bangladesh to commercialize non-certified seed, but the only commercially available rice seed used to be certified seed from the Bangladesh Agriculture Development Corporation (BADC). Apart from the low volume of certified seed produced and its low coverage, lack of desired varieties, delayed seed delivery, and variable seed quality are some of the major constraints.

But there are problems with farm-saved seed too, because it degenerates after several generations of re-use. According to the farmers, it gets 'mixed' with other varieties (due, for example, to handling during harvesting or to farmers planting another variety in the same field as last year), the crop grown from the seed becomes more susceptible to diseases and, most importantly, germination rapidly declines over seasons, especially when the seed is stored during the humid monsoon period (since for Aman and Boro season different varieties are used, the Boro varieties need to be stored during the monsoon period). Thus, farmers do recognize that seed provision is sub-optimal. Because of the sub-optimal seed situation, farmers have been interested in organizing production and marketing of seed locally, instead of depending on an (often unreliable) outside provider. This interest was voiced through NGOs (in Bangladesh almost all farmers are member of an NGO), and more specifically by farmer-seed dealers and BADC-contract growers.

The national seed policy, which was re-formulated in 1993, clearly states that high priority is given to the withdrawal of the public sector and the promotion of the private sector in the production and commercialization of quality seed through small-scale farmer-based seed enterprises, individual farmers, farmer groups or other private entities. In this strategy, the public sector would continue to be responsible for the

development of new varieties, the production of foundation seed, maintaining reserve stocks, etc., for rice and other crops. In line with this, the Bangladeshi seed law defined a 'truthfully labelled seed' class and allows trade of locally produced and labelled seed.

The seed project

The German Government, through GTZ (German Technical Assistance), and some other donors, decided to assist the government of Bangladesh in implementing the seed supply programme, focusing at the same time on the farmers' desire to become 'professional' local seed producers and sellers. In 1997, the Bangladesh-German Seed Development project was initiated with the objective of making quality seed available to farmers through the formation of Farmer-Based Seed Enterprises (FBSE), producing quality rice seed at the local level, and building on farmers' capacity to produce and sell seed. The choice of the model of small-scale farmers' enterprises was also influenced by earlier efforts to enhance farmers' individual seed production capacities in order to improve the quality of own on-farm saved seed. These efforts were not very successful because of lack of training and follow-up.

The project strategy was to collaborate with the BADC, helping them to set up and strengthen FBSEs. Later on, when these groups started to become successful, several NGOs approached the project in order to set up similar seed production with farmer groups to address problems with rice seed supply. Several NGOs buy certified seed from the public sector and supply this to their beneficiaries (as part of a credit-package). Some did set up their own 'seed industry' with grants from donor agencies. Others approached the public sector and the project in order to receive assistance in setting up seed groups at beneficiary level (building on existing groups), with the ultimate objective of creating financially viable and independent farmer seed 'enterprises'. This last approach was promoted and assisted by the German (and later the Danish) project.

The seed project assisted four NGOs in establishing and strengthening farmer seed enterprises: these were Christian Commission for Development in Bangladesh (CCDB), Rangpur-Dinajpur Rural Service (RDRS), Shushilan, and Tarango. The model used in the case of the CCDB is described as an example (see Box 5.1). During the life span of the German project (1997-2004), about 31 FBSEs were established: 22 with BADC and 9 with four NGOs. Later on the DANIDA-supported Seed Industry Development project (2001-2006) continued to support small-scale seed enterprise development in the country (with NGOs, BADC and the Department of Agriculture Extension-DAE). Now, a total of 69 small-scale enterprises and seed groups are operating, involving approximately 1600 farmers (see Table 5.8). In 2004-2005 they commercialized more than 2,000 tons of rice seed of varieties for the Boro and Anan seasons. Increasingly they start to produce and commercialize potato seed and seed of other crops like maize and vegetables (see Table 5.9).

Box 5.1 An example of NGO-supported farmer seed enterprises

Informal groups of about 20 farmers each, already organized by the CCDB for credit (for income generating activities and agriculture) and savings, were confronted with a lack of quality rice seed for planting. These groups had accumulated savings and wanted to invest these funds in local enterprises for seed production and commercialization in their neighbourhood. The farmers formed Private Limited Seed Companies using the 'Venture Capital Concept': 40% of share capital was provided by the CCDB and 60 % by farmers groups and local seed entrepreneurs.*

The CCDB has established its own facilities for seed processing and storage, operated by NGO staff. Farmers are allowed to use these facilities against service charges to cover costs and a small profit margin. The profit share of the CCDB is reinvested in the farmer seed enterprises. Gradually, the CCDB withdraws its share and hands over the seed business to the farmer seed enterprises, which then operate the facilities independently. Farmer seed groups market the rice seed in 10 kg poly-coated bags under the brand name 'Chashir Hashi' ('Farmer's Smile') with a label indicating the quality standard.

* Local businessmen are also farmers from the same communities, but often also engaged in small business; they are 'richer' than the other farmers of the group and able and willing to invest/provide funds for the seed group.

Table 5.8 Total number of farmers' seed enterprises in 2007

<i>Promoting agent</i>	<i>Number of farmer seed enterprises/seed groups</i>
NGOs	18
BADC and NGOs	6
BADC	25
DAE	20
Total	69

Table 5.9 Total volume of seed produced and marketed by 69 farmer seed companies and groups in 2004-2005

<i>Seed crop</i>	<i>Volume of seed sold (tons)</i>
Boro rice	1475
Aman rice	765
Potatoes	395
Wheat	2
Maize	15
Vegetables (tomato, radish, cauliflower, cabbage, carrot, beans)	9
Total	2,661

The organization of small-scale rice seed enterprises

Farmer groups as enterprises

A number of farmer groups have established private limited companies to produce, process and commercialize their rice seed. The steps in the set up of a farmer seed enterprise are described in Box 5.2.

Box 5.2 Steps used in the project to set up farmer seed enterprises*

- Selection of the area and farmers group (by the NGO / BADC, based on interest of farmers);
- Meetings with interested farmers and local businessmen, seed dealers, etc.;
- Formation of an informal seed group;
- Decision and action on formalization of the group (private limited company, or other legal form);
- Carrying out a seed demand survey to identify the present seed market (existing and potential demand); product range (crops and varieties); local production strategies; and market development strategies;
- Training of farmers (seed production, seed business, etc.) by BADC, or NGO;
- Preparation of production plan and marketing plan (business plan);
- Carrying out operations as per business plan (procuring source seed, applying for bank loan, producing seed, arranging processing and storage);
- Organization of field days;
- Promotion of seed and marketing.

Farmers raise money, buying shares (each approximately US\$ 15) for the total value of about US\$ 15-45. Such a company or enterprise buys foundation seed from the BADC, usually of one or two varieties, including newly developed ones. The company members, i.e. the shareholder farmers, produce quality seed under the supervision of the management of the enterprise, assisted by technicians of BADC or the NGO. The harvested seed is processed and stored in a Farmer Seed Centre (FSC), a Seed Processing Centre (SPC) or an NGO processing centre (depending on the model). The quality of the processed seed is checked constantly by technicians from the seed processing units and often cross-checked by BADC. Only seed that meets the national standard is accepted and marketed by the enterprises.

Seed production and processing

The processing units are crucial components in the seed chain for drying, cleaning, and quality control. The processing units are normally equipped with a seed cleaner and seed dryer, and some simple laboratory equipment for seed testing (germination cabinet, Petri dishes, purification board etc.). There are different models for the processing units used by the farmer seed enterprises, which are described below.

* Source: GTZ, 2005. Can I be an entrepreneur? Seed business promotion in Bangladesh. Dhaka, GTZ.

Model 1: Farmers Seed Centres (FSC) provide processing, storage and quality control services to a number of farmer seed enterprises, i.e. private limited companies. FSCs are renovated state-owned fertilizer stores with technicians paid by BADC, the government agency responsible for rice variety breeding and foundation seed production. The German Project financed the renovation of the FSCs and provided small-scale processing machinery and seed testing equipment. An FSC has an independent administration, and is not supposed to make a profit, but costs (including personnel and depreciation for equipment) are covered by the fees paid by the farmers and a specific number of farmer enterprises to which it provides services. The capacity of the FSC is 100-150 tons of rice seed per year, the production of two to three farmer groups. Both BADC- and NGO-supported farmer groups could make use of the FSC.

Model 2: Seed Processing Centres (SPCs) are government-owned and run. They are larger than farmer seed enterprises, providing similar services to those of the FSC and also giving advice and support during production. As in the case of the FSCs, farmer seed groups pay for these services. BADC receives service charges (calculated per kg of seed processed and stored), which cover the cost (if full capacity is used, which is the case now). Both BADC- and NGO-supported farmer groups could make use of the FSC.

Model 3: If there was no SPC in the neighbourhood, the NGOs built up their own seed processing and storage facilities. The farmer seed enterprises pay service charges, which are normally re-invested in the seed processing plant.

Seed marketing

At the time of sales, seed is marketed by the farmer seed enterprises themselves. Farmer seed enterprises trade independently under their own brand name, e.g. Sonali Beez (Golden Seed), Chashir Hashi (farmer's smile). A tag indicating the seed quality is put inside the bags. Rice seed is sold in poly-coated 10 kg bags, with brand name, company, and quality standards printed on the bag. The farmer enterprises, sometimes with the support of the NGO and/or the project, organize field days to promote seed of different varieties. They invite neighbouring farmers to their seed production fields and test plots to show the quality of the rice seed and the performance of new varieties. The seed is sold locally in many different ways – in a small local shop, at a farmers' own house, or just outside the FSC or SPC – but always targeting local farmer clients.

Rice seed is sold at a price ranging from Tk 23-26 /kg (which is about 20-25% above certified seed price, and about double the grain price), differing from location to location, depending on local prevailing prices, demand, variety, etc. Experiences of the farmer seed companies show that farmers are ready to pay a (relatively) high price for quality seed.

Initially the project assisted the farmers' seed enterprises with marketing. It provided advice and resources for a market survey, made some contribution to market promotion (advertisement costs), and advised on marketing strategy. Now the

marketing costs are fully covered by the enterprises themselves; some advertisement/promotion activities (like field days) are still co-financed by promoting agents, i.e. NGOs and BADC. Farmers have now established an association of farmers' seed enterprises (Bangladesh Golden Agri Seed Associates, BGASA) which assists the enterprises with seed marketing. For instance, it channels unsold seed stocks of a particular variety through the BGASA network to an enterprise in an area where there is demand for that variety.

Credit for seed

Linkages with financial institutions are crucial for the business operation of the seed companies, as they often lack the financial ability to meet working capital requirements. When the seed crop is harvested, the seed growers need to get paid for the seed (the seed growers often don't have the financial capacity to wait for a season, till the seed is sold, to get their money). To buy the seed from the seed producers, and to cover processing, testing and storage costs, the enterprises need loans for working capital.

Initially the banks were reluctant to finance these farmer seed enterprises. They were not familiar with the viability of seed business managed by farmer groups. The project then provided a Guarantee Fund to a Bangladeshi bank that was interested, as a security against any defaulting loans from the farmers groups. The collateral for sanctioning loans was actually the quantity of seed stored in the Farmers' Seed Centres and/or the Seed Processing Centres of BADC. With two such security backups, the bank was most comfortable in extending credit facilities to the FBSEs. The Guarantee Fund was kept secret from all the seed groups as well as from the branch level bank officials who would be responsible for loan disbursements to the farmer seed groups. This confidentiality was maintained to prevent the groups from becoming complacent in their activities and reduce the risks of groups defaulting. The secrecy was also intended to ensure that the branch level bank officials would treat the loans as if they were unsecured, rather than being tempted to see them as unimportant loans. Because of the built-in safeguards and the strictness of the system, repayment of the loans is 100% to date.

Reflection

Who buys seed from the farmer seed enterprises and why?

Neighbouring farmers purchase rice seed from the farmer seed enterprises for a premium price: they pay 40-50% more than the grain price, depending on the market price for the grain. There are many reasons why farmers purchase the seed. Farmers are aware that the quality of the seed is higher than that of their own farm-saved seed: they live in the same locality and have seen the fields planted with the seed. Farmer seed companies supply seed of superior varieties. In most cases these are new, improved high-yielding varieties and some enterprises commercialize seed of a purified local variety (e.g. Shona). Using quality seed is more economical. Their own saved seed usually germinates less (for which they compensate by sowing double the quantity of seed) and yields less. Farmers know the seed company members because it

is a fairly local activity. It is known from others studies that this creates a kind of social control and helps to establish a relation of trust. Seed is available nearby and in good time. Farmers are too poor to keep part of their harvest as seed for the next planting, and lack adequate storage conditions, especially for the seed stored over the monsoon season. Generally, farmers keep the seed they purchased from a commercial source for two to three seasons and then buy again. However, no study has yet been carried out to analyse the demand for seed and the basis for decisions as to whether to purchase it or not.

The project as the facilitating agent

The project obviously played an important role at the beginning, when NGOs and farmer groups started out. The project cushioned the initial efforts in the sense that it created the financial space to 'try out' different models. It provided starting costs for seven seed service centres (for the renovation of buildings and machinery). The project helped the newly-formed farmer groups to conduct seed surveys, and provided training on technical, entrepreneurial skills and promotion for farmers and staff of the seed service centres, NGOs and BADC. In addition, it coordinated the involvement of the various actors: the NGOs, BADC and other government organizations and the bank(s). This involved supporting the NGO staff in setting up field days and other seed promotion activities (development of labels, bags, etc), and of advocacy to get political support and set up agreements like those needed to get permission to commercialize farmer seed.

NGOs and BADC as promoting agents

Though the project initially directly assisted NGOs and BADC in setting up farmer seed enterprises, the question arose of how these farmer seed enterprises and the growth of the private seed sector would be sustained after the project period. For this reason, the project considered it important to build the capacities of the NGOs and BADC to support the farmer seed enterprises and their sustainability. These organizations act as 'promoting agents' (service providers) for the established farmer seed enterprises and promote the establishment of new farmer seed enterprises (or other forms of seed producers' groups/individual farmers). They do so through the provision of technical and business services such as training, advice, guidance, monitoring, linkage establishment etc. to their target groups, who eventually form seed business groups.

For these services, both BADC and the four NGOs involved have created special units in their organizations. The BADC has created a 'Private Seed Sector Support Unit' and the NGOs have created units with the special tasks of further promoting and assisting farmer seed groups. These units have trained staff and the BADC and NGOs have allocated budgets to these units to support the farmer seed enterprises. For BADC, the allocation of resources follows from the national seed policy that takes the promotion of private seed groups seriously. The NGOs allocate staff and resources (from external donors) because they are convinced that this concept of farmer seed enterprises works: they see that it is working. Initially, input of staff and budget ('model development costs') has been quite considerable, but this has

diminished over time. Today, BADC and NGOs still maintain these allocations of staff and resources, although seed activities largely cover the costs.

Association of farmer seed enterprises

Another essential factor in the sustainable development of farmer seed groups was the establishment of an association of seed groups. The farmer seed enterprises themselves took the initiative to form the association, Bangladesh Golden Agri Seed Associates (BGASA). BGASA is a professional network of Farmer-based Seed Enterprises and NGOs involved in seed production and marketing, and acts as a common platform. BGASA provides demand-led services to its members such as: the supply of source seed (foundation seed), training, supply of seed bags, credit facilitation, establishment of market linkages etc. It provides these services against certain fees or commissions. The operational expenses of BGASA are currently covered by its own revenues.

Conclusions

Before the farmer seed enterprises appeared, the question why farmers would buy seed and pay a premium price (as compared to grain) was not relevant because BADC was only producing and selling limited amounts of seeds of varieties they did not always prefer and for which they had to travel far (if they even knew where to go). Through the localized operation of the farmer seed enterprises, the seed came within easy reach of farmers, both literally and figuratively speaking. The local level operation also seems to be an important assurance for quality: people know each other and that contributes to the building of trust over time. Surprisingly, however, despite the success of the specialization of rice farmers in seed production and its commercialization, very little information is available on the reasons why farmers buy seed, with what frequency etc. It is argued that especially for self-pollinating and vegetatively propagated food crops with relatively low market prices, commercial seed production is difficult to sustain. Nevertheless, the first farmer seed enterprises in Bangladesh have now been operating for approximately eight years and their numbers have increased remarkably. From the experiences so far, it is clear that a certain coherent combination of measures was crucial for the farmer enterprises to succeed: a supportive national seed policy; an interested donor organization; a project that successfully coordinated and implemented training in seed production with the public sector (BADC), NGOs and farmers, and set up seed processing units, credit facilities and a seed promotion campaign.

Furthermore, continued influx of foundation seed was important to keep seed quality at a high level, and the fact that new varieties were constantly injected into the system by BADC contributed to the attraction for farmers of buying seed for a premium price. Added to this is the access the farmer seed enterprises gained to credit, and their newly-developed entrepreneurial capacity to deal with financial management and credit conditions. Could it be that the concerted action of multiple players, and the perhaps crucial coordination of a special temporary project has helped rice seed production over a critical point? And, with multiple providers 'in business' there are certainly better prospects of a reliable supply of good seed in the future, and

as time goes by, farmers will be more confident that it is worthy buying and using this seed.

5.6 Community-based seed production groups in Chitwan, Nepal*

*Krishna P. Devkota, Mahendra P. Tripathi, Krishna D. Joshi,
Pratap K. Shrestha and John R. Witcombe*

In Nepal, 90 to 95% of the overall seed requirement is fulfilled by the informal system. The delivery of seed to marginal and rural areas is often unprofitable for the commercial seed industry and government organizations because of the high transaction costs involved.¹⁴¹ In a country like Nepal where, as in Ethiopia, many farmers are located in remote areas where conditions are often marginal, the formal seed sector is hardly capable of providing a significant contribution to agricultural development; it has only contributed to development in accessible and high-production environments in the lowlands.

In the domain of the formal sector, and with support from foreign donor agencies, several projects have been implemented to increase the supply of quality seed in Nepal. No lasting effects can be found due to (i) the limited understanding of farmers' needs and preferences, (ii) the restricted information on varietal options, (iii) unreliable access to source seed, (iv) incompatibility of demand and public seed supply, and finally (vii) the rigid nature of the formal seed quality control mechanism.

Since the late 1990s, lessons learned from various seed projects have contributed to a new approach, focusing on locally operating institutions such as community-based and small-scale farmers' seed production organizations or enterprises in order to enhance small-scale farmers' access to quality seed. This new emphasis targets investment in sustainable locally operating entities within both the formal and the informal seed supply system.¹⁴² There is a new focus on the empowerment of community-based organizations. Like the other sections in this chapter, this section presents an approach towards the establishment of community-based and small-scale seed enterprises.

Background

An NGO called Local Initiatives in Biodiversity and Rural Development (LI-BIRD), and an international development and research institute, the Centre for Arid Zone

* This document is an output from project R 7542 and R 8071 funded by the UK Department for International Development – Plant Science Programme (DFID-PSP). The views expressed are not necessarily those of DFID. The authors would like to thank all the participating farmers, DADO Chitwan, the Seed Laboratory, Hetauda, NARC's Rice, Wheat, Maize and Grain Legume Commodity Research Programmes, FORWARD, Agrovets, and LI-BIRD partners and LI-BIRD staff for their contribution to this innovative work.

Studies-Natural Resources (CASZ-NR, UK), in collaboration with the District Agriculture Development Office (DADO) Chitwan and the National Rice Research Programme (NRRP) Hardinath, implemented two projects on participatory crop improvement (PCI) and participatory plant breeding (PPB) in high potential production systems in Chitwan district. Community-based seed production was initiated as a means to disseminate and promote rice varieties developed through both participatory varietal selection (PVS) and PPB. Originally, the project produced seed of developed rice varieties through individual farmers. The project purchased all the seed, and distributed and sold it locally. In 2001, the project team in collaboration with DADO Chitwan, invited some active farmers' groups to participate in seven days of intensive training that focused on the following topics: PVS, seed production, quality control, marketing, certification, co-ordination, networking and group formation. This section presents this experience, outlining the process of group establishment, linking PVS and PPB with seed production, and finally addressing the sustainability of the efforts.

Forming and operating community-based seed producers' groups

Several factors have to be considered before implementing seed production activities in the community. A first step is to use a village-level meeting to create awareness among the farmers about the seed supply situation and the scope and opportunities for seed business.

To start a seed business, the first priority is to identify the production area best suited to the targeted crop. It is a good idea to concentrate on one or two crops. Only those varieties that are adapted to the location should be produced and there should be a clear concept of what and how much to produce.

Individual farmers from a village can be organized and form a seed producers group. The members democratically elect an executive committee to manage the group and sub-committees addressing technical and marketing issues (Figure 5.7). Seed producers' groups may collect monthly contributions from the members or try to obtain funding from other governmental and non-governmental organizations or through credit schemes.

A targeted marketing area should be identified, and groups should assess the production needs for this market. The group should develop the capacity of its members and provide training on group formation, mobilization, seed production, seed quality control, seed certification, marketing, fund raising and resource mobilization, and co-ordination and linkages.

Good quality seed is the bottom line for an assured market. Farmers and other users are willing to pay higher prices for a good quality product. Production of truthfully labelled seed allows competitive and efficient seed production, and also facilitates and encourages seed production by small farmers. Most of the seed producers' groups in Nepal are producing truthfully labelled seed (seed with information kept on the label, e.g. producers' name, crop, variety, year of production, germination percentage, purity percentage, lot number etc), and they have their own labelled bags.

To control seed quality, seed producers' groups use various strategies, including training on seed production. The farmers and the technical sub-committee members also monitor seed production (e.g. varietal purity, isolation, rouging, harvesting method, and threshing) and periodically visit seed fields and verify the quality of the seed in a seed testing laboratory before distribution.

Seed producers' groups plan well in advance the amount of seed to produce, collect and market. A good price attracts good quality and leads to a lasting relationship with the seed-producing farmers. Seed producers' groups set prices on the basis of the actual costs of production, grading, storage and marketing. The seed selling price is usually higher than the seed cost because the group needs to collect a certain amount (Rs 1-2 per kg seed) as group funds.

For assured marketing, seed producers' groups collect orders from various governmental, non-governmental and other private and personal companies, farms, and organizations well in advance before the planting season. The quality of the seed and the range of varieties available are advertised through pamphlets, leaflets and FM radio programs etc. The groups participate in exhibitions, demonstrations, fairs, etc. organized at local and district level.

Figure 5.7 Structure and responsibilities of Shreeram Seed Producers Group, Parbatipur, Chitwan

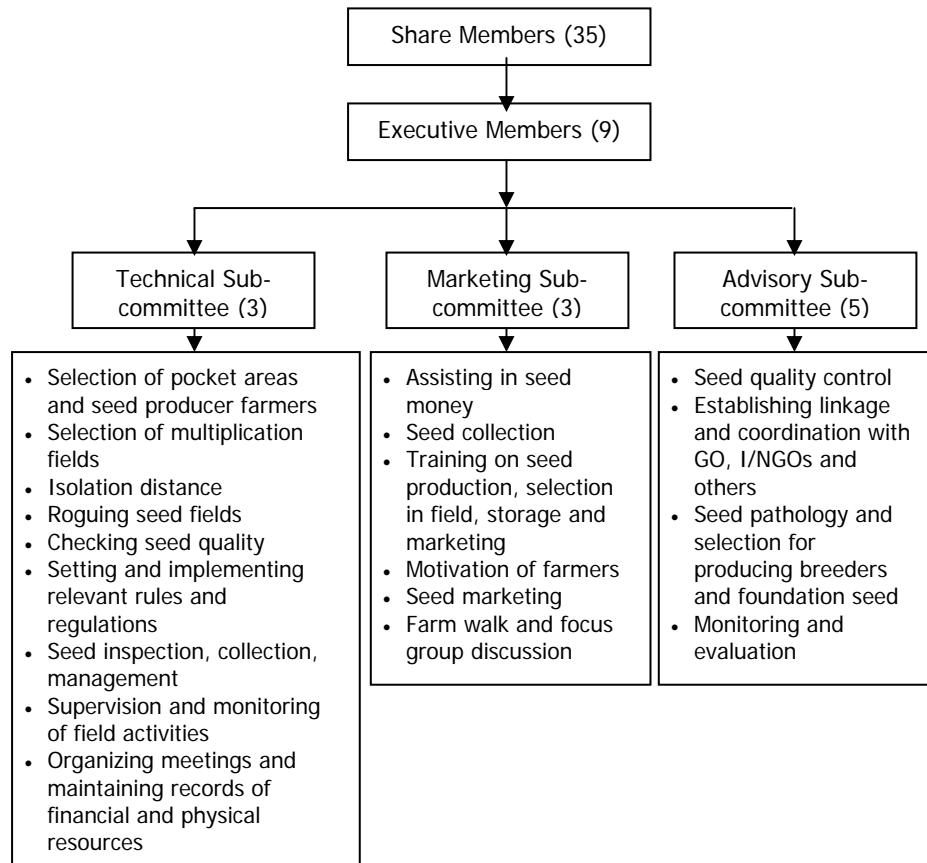

Shreeram seed producer group, Parbatipur, Chitwan

The Shreeram group was established by 35 farmers in 2002. It is legally registered as per the government rules and regulations under the District Agricultural Development Office, Chitwan. There are 15 general and 35 share members. The share members form an executive committee whose members are selected democratically from the general assembly of share members. It has a tenure of three years. Three sub-committees under the executive committee are established; they deal with technical, marketing and advisory aspects. Their roles and responsibilities are described in Figure 5.7. Provisions have been made for inclusion of general members as shareholders. The membership is being advertised and application forms are provided to interested farmers. The committee screens the application forms and shareholder membership is granted to those applicants meeting set criteria.

For future sustainability and strengthening of seed producers' groups, US\$ 1.56 is collected each month from every share member. In addition, governmental and non-governmental organizations are approached for grants and credit. For the year 2006, they donated US\$ 923 from the District Agricultural Development Office (government extension) in Chitwan. LI-BIRD provided technical, managerial, marketing, co-ordination and linkage and empowering in institutional development for the first few years. Table 5.10 describes the type of support provided by various organizations to this seed production group.

Table 5.10 Support and subsidies provided by various organizations to the Shreeram Seed Producers Group

<i>Organization</i>	<i>Type of support and subsidies</i>
DADO Chitwan NARC	<ul style="list-style-type: none"> • Technical support in terms of crop protection and field inspection • Source seed of rice, wheat and maize for producing the truthfully labelled seeds of released and unreleased varieties
LI-BIRD and CAZS-NR	<ul style="list-style-type: none"> • Technical support in terms of seed quality control through crop protection, field inspection, laboratory assessment • Training on seed production, marketing, processing, quality control and seed certification • Co-ordination, linkages and market promotion of the seed • Procurement of source seed • Participatory variety selection and scaling up • Source seed of rice, wheat and kidney bean • Material support like bag sewing machine, winnowing fan, and other need-based materials • Assistance with publicity, advertisement, pamphlets, brochures etc.
FORWARD (NGO) National Seed Company Limited	<ul style="list-style-type: none"> • Source seed of mung bean for seed production • Participatory variety selection and testing • Seed production on contractual basis • Other logistic support for market exploration

The Shreeram group is selling both certified and truthfully labelled seed. They have their own labelled bags. They adopted the procedures described above for the production of quality seed. The support included training workshops before planting, monitoring of the seed production fields by the technical sub-committee, supervision by the Seed Testing Laboratory and DADO Chitwan for following field standards, and laboratory tests allowing grading and authorization of labelling.

The Shreeram group had its own seed sales and distribution network across the country. Initially LI-BIRD, other NGOs and other projects assisted by purchasing significant amounts of the seed produced. In the first year of organized production, LI-BIRD purchased around 37% of the total seed produced. The group had five quintal of seed and they could not sell a single kilogram. In subsequent years, they never faced marketing problems, due to strong linkages with agricultural stores and the private sector. The management committee of the group provided advertising through pamphlets, leaflets and FM radio. Before planning and planting the crop, members of the marketing sub-committee collected orders from agricultural stores, government extension offices and NGOs. Of the total production, the group sold more than 75% of the seed through agricultural stores, 15% through individual farmers and 10% through organizations.

The impact of community-based seed producers' groups in Chitwan, Nepal

Table 5.11 Amount of seed produced and marketed by some of the community-based seed producers' groups in Chitwan district of Nepal (2002-2007)

Name of seed producers group and year establishment	No. of farmers	Seed-producing crops in 2006 ¹	Amount of seed produced (tons)				
			02/03	03/04	04/05	05/06	06/07 ²
Unnat Seed Producers Group, Patihani (2002)	99	Rice (12), wheat (3), maize (1), kidney bean (2), mung bean (1), soybean (1), black gram (1), lentil (1)	1	38	100	137	277
Shreeram Seed Producers Group, Parbatipur (2002)	50	Rice (16), wheat (3), kidney bean (1), rapeseed (2), lentil (2)	2	89	125	135	194
Devujjal Seed Producers Group, Gitanagar (2002)	15	Rice (12), wheat (1), lentil (2)	-	9	13	30	50
Namuna Seed Producers Group, Sukranagar (2001)	90	Wheat (2), maize (2), kidney bean (2)	27	43	51	66	75
Farmers Seed Producers Group, Pithuwa (1994)	300	Rice (8), wheat (3), maize (2), rapeseed (2), lentil (4), kidney bean (3), bean (2)	109	143	179	300	482
Panchakanya Seed Producers Group, Tandil (2000)	50	Rice (4), maize (2)	60	100	125	150	200
Total			199	422	592	819	1277

Notes: ¹ Figure in parenthesis indicates number of varieties of respective crops;

² Targeted and achieved.

Within four to five years after the initial training, Community-based Seed Producers (CBSP) groups in Chitwan are producing and marketing huge amounts of certified and truthfully labelled seeds of improved varieties of various crops, including cereals, legumes and oilseed crops; six CBSP groups marketed 199, 422, 592, 818 and 1277 tons of seed of farmer's demanded varieties from 2002 to 2007 (Table 5.11), providing ample varietal choice to the farming communities of more than 35 districts of lowland and mid-hill regions of Nepal.

Links between PVS/PPB and community-based seed producers' groups

Three groups are linked with PPB and PVS activities. They are producing and marketing varieties resulting from this work, including not yet released varieties and materials. Once the new varieties become better known, the seed producers' groups include them in commercial production. Linking groups with PVS and PPB provided opportunities to identify and select better performing varieties for each locality. When compared with groups that focus on local and released varieties, the groups linked with PVS and PPB progressed more rapidly in terms of seed production and their seed business. For those groups, the number of crops, varieties and market areas have increased. They provide farming communities with a choice, and with access to crops and varieties. In an indirect way, they contribute to agrobiodiversity conservation. It can be concluded that, in terms of crops and varieties, the groups play an important role in the nation's biodiversity enrichment. When taking into account the diversity of crops and varieties they make available to farmers, the contribution of seed producers' groups is to be considered more substantial than that of the government-managed and -funded national seed company (see Figure 5.8).

Figure 5.8 Diversification in seed production of various crop species (in percentage) by six community-based seed producers' groups in Chitwan and the national seed company (NSC) of Nepal in 2006

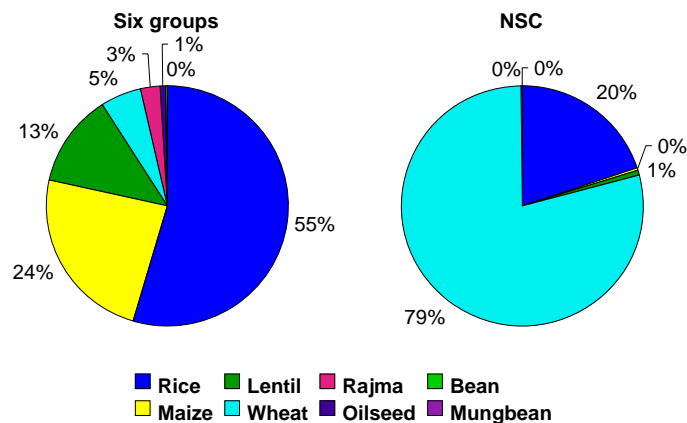

Community-based seed production is a three dimensional profit-making approach, i.e. with benefits to seed producer farmers, to seed producer groups, and to growers using quality seed of improved varieties. Table 5.12 demonstrates how various groups have

moved towards profit making in three to five years. During the initial years, some groups could not sell all their seed due to poor marketing strategies. However, through training, and supporting the development of market channels this barrier was quickly overcome. Consequently the CBSP approach became an important option for increasing farmers' access to the quality seed of released varieties, as well as to varieties resulting from PPB in Nepal. The groups' growing economic viability showed that they have been empowered and are becoming important players in the seed sector.

Table 5.12 Income and expenditure of various community-based seed producer groups (Group evaluation)

<i>Seed producers group</i>	<i>Total cost (US\$)</i>			<i>Total income (US\$)</i>			<i>Net profit (US\$)</i>		
	<i>2002-03</i>	<i>2003-04</i>	<i>2004-05</i>	<i>2002-03</i>	<i>2003-04</i>	<i>2004-05</i>	<i>2002-03</i>	<i>2003-04</i>	<i>2004-05</i>
Unnat Seed producers group, Chitwan	1925	7942	14085	2108	30	16901	183	1620	2817
Shreeram seed producers group, Chitwan	-	880	10451	-	1048	11570	-	168	1120
Devujjal seed producers group, Chitwan	-	-	929	-	-	988	-	-	59
Surayadaya Bahu Uddeshe Krishak sahakari Sanstha Ltd.	3225	3437	7028	6155	7070	14620	2930	3634	7592
Bela - 2 Dang Nawa Adharsha Farmer Seed Producers Group, Jhapa	NA	NA	NA	352	5	451	NA	NA	NA

Conclusion

The approach and experience presented in this section is a community-led, profit-motivated business approach supporting seed supply. Farmers look at seed production as an enterprise. It is a collective activity which includes collaboration with national research and extension services, other government departments, NGOs, private companies, government seed testing laboratories, agricultural stores and, most importantly, the community. Seed production, marketing, quality control and strengthening institutional capacity in the group are integrated. Farmers are successfully linked to private seed companies and entrepreneurs, e.g. the agricultural stores. The members of the group have a clear sense of ownership. A considerable amount of indigenous knowledge, skills and technology within the farming community in seed management has been invested to produce seed of equal or better quality than the formal sector seed. Because of its integrated nature, the group pays more attention to institutional, economic, technical and managerial factors, using participatory methods.

Government involvement in seed supply has been declining and viable commercial seed supply mechanisms have not yet been filling the gap. Reviewing the

efforts made during the last fifteen years and taking into account the experiences with the seed production groups or enterprises, the proposed system appears the only sustainable way to supply Nepal's growing demand for seed. Government and policy makers should adopt and mainstream this approach as national policy. If an enabling legal framework is provided, such organizations could play a vital role in sustaining the seed supply system.

6 Initial experiences of supporting the establishment of community-based and small-scale seed enterprises in Ethiopia

Introduction

Chapter 5 presents concepts, approaches and a number of case studies of successful attempts to improve farmers' access to seeds by establishing small-scale and community-based seed enterprises. Chapter 6 narrows the focus and describes the first experiences with this approach in Ethiopia. Section 6.1 concerns the experiences of an FAO seed security project implemented from 2002 to 2007 in Oromia region; sections 6.2 to 6.6 bring together the experiences of five regional teams, from Amhara, Oromia (two teams), SNNPR, and Tigray regions, that were involved in a one-year tailor-made training programme on revitalizing farmer-based seed production and supporting informal seed supply of local crops and varieties in Ethiopia, from October 2006 to October 2007.* The teams consisted of seed sector professionals from the Ethiopian Seed Enterprise (ESE), the regional Bureaus of Agriculture and Rural Development (BoARDS), the federal and regional Agricultural Research Institutes, and some representatives from the Ministry of Agriculture and Rural Development, the Institute of Biodiversity Conservation, universities, and NGOs. The teams started with a first training workshop on informal seed supply, genetic diversity and the principles of participatory and learning-oriented approaches, and a second workshop on technical and institutional aspects of seed production and marketing, and business approaches supporting informal seed supply. After these trainings, the teams performed a participatory seed system analysis in their respective regions to identify the seed supply problems and define options for supporting informal seed supply. They also conducted a marketing survey to explore the options for developing market-oriented small-scale seed enterprises, and drew up business plans. The seed system analyses and business plans were discussed, shared in the training, and used to design an action plan for the implementation of a community-based or small-scale seed enterprise in each region. Sections 6.2 to 6.6 present the seed supply situation in specific locations in the different regions, the plans for and first results of the establishment of the community-based or small-scale seed enterprise, some results of the first field experience, the constraints and challenges encountered, and opportunities and future prospects.

* See Section 1.5 by Marja Thijssen and colleagues on the set-up and lessons learnt of the tailor-made training programme.

6.1 Cooperative community-based seed enterprises in Hararghe, Ethiopia: strategy and first lessons learnt*

Osman E. Ibrahim

Food security is recognized as one of the main challenges in the drought-prone areas of Eastern Africa where seed insecurity is a major factor contributing to food insecurity. In the drought-prone areas of Ethiopia, seed insecurity contributes a great deal to the inefficiency of the agricultural sector. This section of the current chapter shares the experience of a project that supported the establishment of Cooperative Community-based Seed Enterprises (CCBSE) and the model used for establishing the CCBSEs. It provides the key activities through which the project aimed to support informal seed supply. In conclusion, it shares some lessons learnt on the model, and in particular the need for seed projects and those targeting CCBSEs or similar structures to work through the regional BoARD structure and other regional and local development agencies.

Seed security in Hararghe Zone in Eastern Ethiopia

The seed insecurity situation in the drought-prone areas of Ethiopia in general and Hararghe zone in particular, is created and aggravated by economic as well as environmental factors. The major constraints are lack of infrastructure, lack of improved and adapted varieties and seeds, and lack of services by formal sector agricultural institutions such as research, input suppliers, and extension. Many traditional semi-arid production areas are remote, which causes serious marketing barriers for service providers as well as for markets for farm produce. Recurrent droughts and the need for repeated replanting in the same season have made traditional farmers' seed-saving practice an unreliable source for planting in subsequent seasons. Drought is therefore considered the primary cause of seed insecurity.

Seed insecurity in Hararghe is aggravated by land scarcity, tenure and fragmentation and the nature and diversity of the traditional subsistence farming systems. The situation is further aggravated by successive years of severe drought or erratic rainfall, which require repeated re-planting. Farmers' seed-saving practices have become unreliable, while neither emergency seed supply interventions nor past seed multiplication projects have had a sustainable impact on seed insecurity. The capacity of the informal seed sector to maintain a secure supply of appropriate seeds for the dry land or traditional farming systems areas is inadequate.

Hence, there is a need for a more sustainable seed security system among the food insecure communities in order to strengthen production and/or income

* This work is an output of the FAO-Seed Security Project--GCP/ETH/062/NOR (2002-2007), which has been funded by the Royal Norwegian Government

generation capacity of the farmers. In the absence of seed provision for the drought-prone regions of Ethiopia, the introduction of drought tolerant and/or short-maturing local and improved crop varieties combined with crop diversification and informal on-farm seed multiplication schemes is an attractive and highly justifiable option. In the meantime, there needs to be an emphasis on improvement (pure-line and mass selection) and on-farm seed multiplication of local varieties which are characterized by high adaptation and acceptability. This was the rationale for the implementation of the project entitled '*Strengthening seed supply systems at the local level in Hararghe zones in Eastern Ethiopia*'. With funding from the Norwegian government, the Government of Ethiopia and the FAO implemented the seed security project in the years 2002-2007, working on two main processes. The first of these was crop production improvement through on-farm seed multiplication, production, storage and marketing of seeds of improved and local farmers' cultivars of selected food crops. And the second one was promotion of crop diversification through demonstration plots and the production of seeds of cash crops that could increase the farmers, income. This section focuses on the support to the establishment of community-based seed enterprises.

The strategy for the establishment of community-based seed enterprises

A systematic approach is critical in the assessment, planning and development of CCBSEs. The approach used included the following steps:

1. Informal discussion with officials at the regional, zonal and woreda levels about the CCBSEs, for awareness creation and development of criteria for a structured survey to identify potential zones and woredas. In general, criteria include location accessibility, resources, crop rotation, level of seed awareness, availability of land, potential for irrigation, functional community organization, seed market and the capacity of the Office of Woreda Agriculture and Rural Development to assume leadership.
2. Training of extension staff to conduct the survey to select zones and woredas within them, based on the criteria set during step 1 above.
3. Informal discussions with selected communities on establishing CCBSEs, to explain the model and take note of farmers' concerns. In general, criteria for community level surveys are the same as shown in step 1 above, but with more details on each criterion.
4. Training of community development agents to conduct the survey to select the appropriate communities and sites and functional community organization, based on criteria developed in step 3 above.
5. Conducting the base line survey, analysing the results and selecting appropriate communities and sites for establishing the CCBSE unit.
6. Training and orientation for the selected zones, woreda staff and community groups on group formation and the project strategies for on-farm seed multiplication and marketing.
7. Establishment of the CCBSE as a legal entity based on a signed agreement between the CCBSE and Agriculture and Rural Development Office of the woreda concerned.

8. Identification and provision of critical seed supplies and equipment on a credit basis with easy repayment arrangements.
9. Establishment of community seed stores.
10. Implementation of seed production and establishment of a revolving fund.
11. Conducting a capacity building program, including training, extension and field demonstration, professional workshops, study tours, etc.
12. Linking the CCBSE unit with key stakeholders including research institutes, and formal and informal seed supply systems.
13. Linking the CCBSEs with markets.

The model of community-based seed enterprises

The model for the organization of CCBSE is simple and self-contained; the focus is on the establishment of a cooperative at community level. An adequate knowledge of farmers' organizations is required for the design. Given this, access to appropriate technologies and facilities will enable the cooperative to plan and handle the seed production operations from planting to cleaning, marketing and distribution. Based on these components, the CCBSE model was designed in the project, and a process involving three guiding topics was used for its implementation. The topics are the following: (i) community organization and technical, operational and administrative establishment of the enterprise; (ii) the development and dissemination of appropriate varieties, seeds and technologies; and (iii) crop biodiversity maintenance and on-farm conservation.

Support in the establishment of the enterprise

The organization and establishment of a CCBSE unit, includes the set-up of a cooperative organization, establishment of seed cleaning facilities, strengthening of seed storage capacities, and selling points. In addition, contractual arrangements between the CCBSE and individual farmers in the community need to be fostered. The CCBSE unit is community-based, owned and managed; it plays a major role in leading and running all the CCBSE activities. Planning and execution is in the hands of the community organization, with initial managerial and technical, support, guidance and supervision provided by the woreda's extension agents and experts.

Simple, practical and affordable local technologies, inputs and procedures are used within the CCBSE operations for seed production, quality control, and post harvest cleaning, packaging and storage. The farmers concerned play the major role of establishing the enterprise seed facilities and assets, by contributing all required agricultural land, labour, and locally available construction materials. Each CCBSE starts with the establishment of a more than five hectare cooperative-owned seed farm. The project provides capacity building and technical support, supervision and guidance in terms of training, field operations follow-up and backstopping. In addition, the project furnishes the CCBSE with initial seeds, other agriculture inputs and critical items for seed cleaning and the construction and management of simple seed stores.

The project sees contractual seed production as the most important activity. The CCBSEs advertised an agreement for contractual seed multiplication by interested

seed growers in the community. The agreement places particular emphasis on the major cereal food crops (maize, sorghum and wheat) and selected cash crops (potato, onion and haricot beans). Standard field cultural practices for seed crop establishment and quality control practices were performed under the direct supervision and technical guidance provided by the project field staff and the woreda development agents and experts.

In the course of project implementation (2002-2007), four CCBSE units have been established, and four are currently under establishment. Profile information on the project CCBSE units established in East Hararghe, and those under establishment in West Hararghe and East Shoa, is summarized in Table 6.1, including the location, human resources, crops, facilities and the major constraints.

Seed production

Table 6.2 shows the CCBSEs' seed production data, including the amounts of seed delivered, areas planted and estimates of total seed production over the period 2003 to 2007. Initially the activities of the CCBSEs were limited to the multiplication/demonstration plots of selected crop varieties at the CCBSE seed farms. This is because of the following reasons: (i) a severe scarcity and shortage of initial seeds (pre-basic and basic seeds), (ii) the emphasis given to seed quality and demonstration of the standard practices for quality seed production, and (iii) the need for familiarizing the members with the concept, arrangements and agreements of the CCBSE contractual seed multiplication scheme. Some of the data on total seed production in Table 6.2 are based on estimates. Actual yields are difficult to obtain due to several factors: (i) the tendency of the seed growers not to abide by the terms of the contractual agreement, e.g. demanding higher prices than initially agreed upon, and giving priority to the distribution of the produced seed to relatives, friends and neighbours in the community, (ii) the need to reject a number of contractual seed fields because of poor seed quality, (iii) insistence of the CCBSEs on involving all their members as contractual growers, often resulting in poor follow-up on the seed production, quality control and final collection, (iv) The CCBSE units' initial lack of financial capital to purchase all the seeds produced on a contractual basis, (v) the priority given to the collection of seed of improved crop varieties, primarily of cash crops such as potatoes and legumes, which have superior market value and generate better income, (vi) poor follow-up by woreda field staff coupled with the CCBSE members' initially limited experience of contractual seed production planning and management. However, during the past two years the situation has improved, with the CCBSEs becoming more organized and accustomed to the seed production management, particularly in the new expansion areas in East Shoa zone.

Table 6.1 Profiles of cooperative community-based seed enterprises in East Hararghe (2003 – 2006/7), West Hararghe and East Shoa (2006/7) Zones

	<i>J. Gemechu</i>	<i>H. Gudina</i>	<i>J. Belina</i>	<i>B. Jallalla</i>	<i>Wonagle</i>
<i>Basic general data</i>					
Foundation	Nov. 2003	Feb. 2003	June 2004	June 2004	March 2005
PA	Emerosodu	Ifa-jallalla	J. Belina	Fughan Bira	Wonagle
Woreda	Kerssa	Kerssa	Kurfachelle	Gursum	Gursum
Proximity to woreda main town	3 km	18 km	2 km	18 km	15 km
Accessibility to zonal main town	41 km	58 km	57 km	93 km	80 km
Road condition	Good	Good	Good	Fair	Fair
Population PA	-	3,423	6,895	2,985	-
Population woreda	142,505	142,505	45,417	149,889	-
<i>Human resources</i>					
WARDO experts	14	14	13	11	11
WRDO Das	16	16	19	13	13
CCBSE members	41	211	300	68	68
Members > 4 th grade	1	4	2	2	2
<i>Crops and facilities</i>					
Major crops	Maize, potatoes	Maize, potatoes	Wheat, potatoes	Wheat, potatoes	Sorghum, maize, legumes
Communal seed farm	> 5 ha	> 8 ha	3.5 ha	3.0 ha	> 10 ha
Irrigation	Pump	Pump	Pump	Gravity	Pump
Seedling nursery	Yes	Yes	Yes	-	-
Processing equipment	-	Seed cleaner	Seed cleaner	-	Seed cleaner
Packaging & labelling	Weigh scale	Weigh scale	Weigh scale	Weigh scale	Weigh scale
Seed storage	-	Seed store	Seed store	Seed store	Seed store
Village seed shop	-	Yes	-	Yes	-
Power source	-	Generator	Generator	-	Generator
<i>Constraints*</i>					
Enforcement of agreements	4	5	5	0	0
Membership size	5	0	0	0	0
CCBSE leadership	2	5	5	4	2
Cooperative organization	2	3	3	0	5
Dependency syndrome	3	5	5	3	3
Contractual seed production	3	3	3	4	3
Communal land	0	0	0	5	3
WARDO technical support	4	4	4	3	4
Market orientation	0	1	2	3	0

Table 6.1 Continued

	<i>Hargei</i>	<i>Bibilo</i>	<i>Biftu</i>	<i>B. Hawai</i>
<i>Basic general data</i>				
Foundation PA	2006/07	2006/07	2006/07	2006/07
Woreda	Mieu	Mies	Lummee	Gimbichu
Proximity to woreda main town (km)	25	13	5	2
Accessibility to zonal main town (km)	50	38	60	90
Road condition	Seasonal	Seasonal	Good	Good
Population PA				
Population woreda				
<i>Human resources</i>				
WARDO experts	13	13	11	12
WRDO Das	23	23	26	31
CCBSE members	45	55	150	210
Members > 4 th grade	2	1	> 10	> 10
<i>Crops and facilities</i>				
Major crops	Sorghum, maize, legumes	Sorghum, maize, legumes	Lentil, wheat, chickpea	Lentil, wheat, chickpea
Communal seed farm	> 15 ha	> 15 ha	5 ha	2.5 ha
Irrigation	Gravity	Gravity	-	-
Seedling nursery	-	-	-	-
Processing equipment	Under duplication	Under duplication	Under duplication	Under duplication
Packaging & labelling	Under procurement	Under procurement	Under procurement	Under procurement
Seed storage	Under construction	Under construction	Under construction	Under construction
Village seed shop	Under construction	Under construction	Under construction	Under construction
Power source	To be determined	To be determined	To be determined	To be determined
<i>Constraints*</i>				
Enforcement of agreements	3	3	0	0
Membership size	0	0	0	0
CCBSE leadership	2	2	0	0
Cooperative organization	3	3	1	1
Dependency syndrome	3	3	0	0
Contractual seed production	1	1	1	1
Communal land	0	0	3	3
WARDO technical support	4	4	3	3
Market orientation	2	2	0	0

Note: * Magnitude of constraints from 0 (absent), 1 (low) to 5 (high).

Table 6.2 Seed production (in quintals) of the cooperative community-based seed enterprises in East Hararghe (2003 – 2006/7), West Hararghe and East Shoa (2006/7) Zones

	<i>Crops</i>					
	<i>Maize</i>	<i>Wheat</i>	<i>Sorghum</i>	<i>Teff</i>	<i>Pulses¹</i>	<i>Potato</i>
<i>Eastern Hararghe</i>						
J. Gemechu	107.4	239.8	309.6		128.2	123.4
H. Gudina	37.5	131.5	501.0		161.0	237.0
J. Belina	1200.0	152.0			97.5	2.5
B. Jalala		105.0				245.0
Wonagle	960.0		5,190.0		197.0	
<i>West Hararghe</i>						
Hargeti ²	Na		Na			
Bilibo ²	Na					
Others (06/07) ³	1262.5	627.5	246.0	251.0	28.0	
<i>Eastern Shoa</i>						
Biftu		2,188.3			410.0	
B. Hawaii		1,662.5			346.0	
Grand total	3567.4	5106.6	6246.6	251.0	1367.7	607.9

Notes: ¹ Pulses = chick pea, haricot bean, lentil; ² Seeds provided for planting, but no data available yet; ³ Contracted seed growers at Koni, Dar Labu, Tulu and other locations.

Seed multiplication and varietal demonstration plots

Varietal seed multiplication/demonstration plots were established, in cooperation with national technology generation and transfer institutes, to enable participating CCBSEs to have access to improved varieties and other seed production technologies. The plots were useful for the selection of improved varieties and indigenous germplasm accessions of food and cash crops. The trials were setup for testing maize, wheat, haricot bean, potato, chickpea and onions varieties and accessions. To demonstrate and promote crop diversification of export cash crops, seedling nurseries for vegetable and other horticultural and forest crops were established at each CCBSE seed farm to provide planting material (seedlings) for orchards and gardens. Seeds of potential export vegetables, including carrot, onion, Swiss chard, egg plant, cabbage, tomato, cauliflower, beet root, leek and lettuce, were distributed for plantation and demonstration purposes. The numbers of crop/variety seed multiplication/demonstration plots established in the project's three zones are presented in Table 6.3.

Crop biodiversity maintenance and on-farm conservation

On-farm conservation and maintenance of indigenous crops and local varieties is essential for stabilizing and improving crop productivity. It represents a mechanism for coping with the risk of drought-induced crop failure and eventual seed insecurity. The project model therefore emphasizes on-farm conservation of crop biodiversity, through on-farm multiplication of local varieties. In collaboration with the Institute of Biodiversity Conservation (IBC), the project

Table 6.3 Number of varietal seed multiplication/ demonstration plots established by cooperative community-based seed enterprises in East and West Hararghe and East Shoa Zones (2003-2007)

<i>Crop</i>	2003	2004	2005	2006	2007	Total	Source
<i>Cereals</i>							
Wheat	7	14		3	7	31	KRC
Wheat (Acc.)*	44					44	IBC
Durum wheat					2	2	DRC
Maize	13	17		3		33	MRC
Maize (Acc.)	8					8	IBC
Sorghum	11	14		9		34	MRC, AU
Sorghum (Acc.)*	48					48	IBC
Teff				5	4	9	DRC
Barley				2		2	KRC AU
Barley (Acc.)*	10					10	IBC
<i>Legumes</i>							
Haricot	6	19		12		37	MRC,HRC
Haricot (Acc.)*	9					9	IBC
Lentil				4		4	DRC
Chick pea	3	1		4		8	DRC
Faba bean				3	4	7	KRC,HRC
Faba bean (Acc.)*	2					02	IBC
Field pea				2	4	6	KRC,HRC
Field pea (Acc.)*	8					8	IBC
Fenugreek (Acc.)*	22					22	IBC
<i>Vegetables</i>							
Potatoes	4	14			6	24	AU, HRC
Onion	1	4				5	MWRC
Others		6				6	
<i>Oil crops</i>							
Sesame	4	15				19	MWRC
Sesame (Acc.)*	6					6	IBC
Groundnut	6	15			4	25	MWRC
Groundnut (Acc.)*	1					1	IBC
Sunflower (Acc.)	4					4	IBC
Total	217	119		47	31	414	

* Accession of mostly indigenous germplasm; KRC = Kulumsa Research Center; IBC = Institute for Biodiversity Conservation; DRC = Debre Zeit Research Center; MRC = Melkassa Research Center; HRC = Holeta Research Center; AU = Alemaya University; MWRC = Melka Were Research Center.

conducted the collection, purification, documentation, multiplication, and dissemination to farmers of local varieties*. In cooperation with the IBC, 161 germplasm accessions were reintroduced that were originally grown in Kersa and other neighbouring woredas. The reintroductions included the crops sorghum (48 accessions), maize (8), wheat (44), barley (10), fenugreek (22), haricot beans (9), field

* In Section 3.4, Girma Balcha and Tesema Tanto go into more detail about this approach linking conservation of local crops and varieties and supporting informal seed supply in Ethiopia.

pea (8) beans (2), sesame (6) and sunflower (4). The accessions were included in a demonstration plot for farmer observation at the Haqina Gudina CCBSE seed farm in the 2003/4 cropping season. The reintroduced local varieties were also used for participatory varietal selection, multiplication and utilization.

Lessons learnt and options for application of the model in other regions

A model for establishing CCBSEs was tested and refined on the basis of the experience of the project. The project-established CCBSE units are community-based, community owned and managed schemes for seed multiplication; they promote crop diversification and on-farm conservation of biodiversity, and use of local resources and simple affordable technologies. Eight CCBSE units have been established in three woredas in East Hararghe (4), one woreda in West Hararghe (2) and two woredas in East Shoa (2). In their short existence, these CCBSE units have demonstrated that the seed security of the rural communities can be increased. Other activities of the seed security project also contributed to increasing crop productivity, diversification and seed development. The project model was noted to have been widely accepted among rural communities, and good progress has been made on the institutional side at the community level. This confirms the community's need for and appreciation of the service delivered by the CCBSE unit. The lesson learned from the above is that it is possible to establish CCBSEs with the full participation and ownership of the community.

CCBSE communities should have a strong history of working together in community activities. One community (Namely Wanagli CCBSE) came to the project to request assistance, and ended up being one of the most successful because of strong community leadership and cohesion.

Precise data on seed production and marketing are difficult to gather through the extension staff. Much of the seed produced was marketed directly in the community.

Analysis of major differences between different woredas and agro-ecological zones in respect to establishment of CCBSE indicated that the poorer and more drought-prone zones were less likely to establish viable CCBSEs. This was attributed to several factors, including the erratic nature of the rainfall, poor access to markets, and the lack of cash crops.

A key lesson learnt from the project in Hararghe is that the structures for supporting CCBSEs should be properly embedded in the systems of the relevant stakeholders, particularly those of BoARDs, the Cooperative Commission, the formal seed system (EARO, ESE and the universities), and components of the informal seed system. CCBSEs and any project supporting their development should maintain vital linkages or be integrated within the formal and informal seed system. Institutional sustainability at all levels is of vital importance for the project's future impact and upscaling. For building such institutional sustainability, the following factors must be considered:

- It is essential that there is substantial ownership, leadership and follow-up from the agriculture and rural development bureaus and offices at regional, zonal and woreda levels, particularly in respect to provision of technical support and

guidance in all seed production operations and practices from field selection through seed production and marketing.

- Integration of the project into relevant government and other key stakeholder institutions' structures is critical for securing institutional sustainability for successful implementation and future upscaling and expansion of the project in new seed-insecure areas.
- Agreements should be established that organize and govern community participation and commitment.
- There should be clarity on the concept of business and market orientation and that the CCBSE is a private community-based, owned and managed business.
- The CCBSE needs linkages with the formal and informal seed production systems including, research, extension, cooperatives and credit and marketing systems.
- It is important to build the farmers' capacity for organizing, leading and managing seed-related agro-business activities, particularly the entrepreneurial skills of CCBSE members.
- The task of building and maintaining sustainability at the community level is made difficult by the prevalent dependency syndrome created by repeated food, seeds and other relief interventions. This situation requires cautious, diplomatic, but firm handling to lead the local communities from a relief orientation to a development/business one.
- Simple and affordable local rural technology and inputs should be used as much as possible.
- For the model to be expanded to other areas, it should be reoriented so that the government has a central role in facilitating the establishment of institutional sustainability, and relevant national authorities play a larger role in the project ownership, leadership, planning and management.

Effective integration of any such project should be guided within the BoARD under the regional government and the respective offices at zonal, woreda and PA levels. The woreda BoARD offices should be front line implementers. The Development Agents (DAs) in each woreda should be the main development actors working within a community at peasant association level. The Regional Cooperative Promotion Commission (CPC), should be actively involved through its experts at various levels, and should be responsible for issues related to organizing production cooperatives, group formation, marketing of seeds, credit, and training and capacity building of beneficiaries, in respect to developing and strengthening their business and entrepreneurial skills.

The practical experience and confidence gained over five years helps to motivate other organizations supporting the development of small-scale and community-based seed enterprises in Ethiopia and other sub-Saharan countries. The progress made is appreciated by all the parties involved, including the donors, implementing partners, stakeholders and, most importantly, the beneficiary farming communities.

Seed quality standards and certification should be part of the project, but this component needs more attention so that farmers will have confidence in certified

seed. It is expected that acceptance of seed quality standards will eventually develop along with knowledge about seeds, experience of seed production, and the competition between the CCBSE units and other seed suppliers. Meanwhile, the FAO 'Quality Declared Seed Standards' offer a reasonable option for dealing with seed quality standards in the context of informal on-farm seed multiplication. These standards should be adopted in the national seed policy, to promote informal seed multiplication.

These lessons learnt suggest that, to develop institutionally sustainable CCBSE units, it will be necessary to adopt a business model,* and to transfer business skills to the units and help them to develop the marketing structures required for success. Through studies aimed at understanding market parameters such as demand forecast, product promotion to boost demand, demonstrations and trials, to strengthen the basis for the seed replacement efforts, and linkages to potential consumers and market facilitators. For the CCBSEs to become economically viable organizations, they need to develop into profitable and effective business entities able to offer the required services to the target rural communities, and adequate returns to their owners.

6.2 Avola Goshiye Community-based Seed Enterprise in Yilmana Densa woreda, Amhara region[†]

Amelework Beyene, Alem Yalew, Abebew Assefa and Yimam Tessema

The Amhara National Regional State (ANRS) occupies most of the north-western and north-eastern parts of Ethiopia. Agriculture is the mainstay of economy, and about 88% of the population depend on agriculture for their livelihoods. Animal husbandry and crop production are the two main agricultural activities, and crops include cereals, pulses, oil crops, fibre crops, fruits and vegetables. A high population growth rate of 2.9% p.a. has a big impact on the growth of the sector, creating fragmented land holdings and adversely affected land management by causing erosion and making soil and water conservation difficult.

Low productivity coupled with depletion of the natural resource base has made agriculture a risky business. This challenge calls for immediate intervention in research and development. Generation of economically feasible, socially acceptable and

* In Section 5.2, Antony van Gastel, Zewdie Bishaw and Bill Gregg give an overview of the business principles to be embraced for the establishment of institutionally and economically viable small-scale seed enterprises.

† This section is an output of the Amhara regional team participating in the ESE/WUR/ICARDA Tailor Made Training Programme on Revitalizing the farmer based seed production and supporting informal seed supply of local crops in Ethiopia, supported by Nuffic (The Netherlands).

environmentally friendly agricultural technologies is vital to increase production and productivity per unit area of land. Although one can not deny that the technologies at hand are not adopted by farmers, they are also not properly popularized and seed is not available to the farmers.

The seed supply situation in Amhara region

In Amhara region, the use of improved technologies such as agro-chemicals, improved seed and farm equipment is in its infancy. Currently, the formal sector is not in a position to meet the seed demand of the region, where the informal sector accounts for 88% through local seed exchange. Seed of local varieties can be obtained through purchase, gift or exchange. Seed of improved varieties can be purchased from agricultural research, the Ethiopian Seed Enterprise (ESE) or the Bureau of Agriculture and Rural Development (BoARD). More recently, some private investors have got involved in seed production and marketing. However, due to the vast area, the formal system is unable to satisfy the seed demand of the region. As a result, farmers remain associated with locally produced seed and their local varieties. A possible option for overcoming this constraint is to mobilize farmers to produce quality seed. One of the ways to do this is to organize seed grower cooperatives or develop community-based seed enterprises.

The new economic policy of the country, Agricultural Development-Led Industrialization (ADLI), has clearly identified poverty, land degradation and low agricultural productivity as the main challenges. Poverty reduction largely depends on how land and other resources are utilized. By implication, ADLI favours agriculture and agricultural research and development activities. It will therefore provide a great opportunity to support seed grower cooperatives and community-based seed enterprises. Seed experts representing the Amhara BoARD, the Amhara Regional Agricultural Research Institute and the Ethiopian Seed Enterprise participated in a tailor-made training programme supporting informal seed supply. Upon initial training, the Amhara team conducted a participatory seed system analysis and a seed demand survey in Yilmana Densa woreda. This section focuses on the outcome of the participatory seed system analysis as conducted in November – December 2006, which forms a basis for the establishment of a community-based seed enterprise (CBSE) in Yilmana Densa woreda, west Gojjam zone, Amhara region located 43 km southeast of Bahir Dar along the road to Addis Ababa.

Overview of the enterprise

The objectives of the enterprise are to (i) empower farmers to produce quality seed; (ii) assure sustainable and quality seed supply in the area; (iii) improve the livelihood of farmers by generating income from seed sales; and (iv) create job opportunities for farmers of the area. The CBSE is located in Goshiye Kebele of Yelimana Densa woreda in West Gojjam Zone. The enterprise is named Avola Goshiye Community-based Seed Enterprise, after a famous hill nearby Adet town and the kebele. From four surveyed kebeles, Goshiye is selected because of the availability of irrigation facilities. There are over 400 ha of irrigated land. Farmers were already involved in seed production in collaboration with Adet Research Centre, and are especially

experienced in potato seed production. A total of 15 ha of land is required, of which 10 ha for hybrid maize and 5 ha for potato. From our survey, the average landholding is 0.25 ha; about 60 farmers will therefore participate in seed production.

Legal form and structure of the enterprise

A cooperative-based seed enterprise is suggested because there are strong and active cooperatives in all the surveyed areas. The cooperatives have active members, as well as offices, stores, and other facilities. Additionally, they are engaged in agricultural input supply and other off-farm activities. They purchase grain during peak production time and sell it when the price is higher. The cooperatives are an ideal basis for a strong seed business. However, due to previous bad experience with cooperatives, farmers are reluctant to join already existing cooperatives. Discussion with farmers revealed that this is a very sensitive issue. The team suggested that farmers should solve their problems by themselves without much external interference. A committee of four farmers' representatives was established to resolve the problem with the assistance of a cooperative agency representative and the development agent. The committee has the mandate to discuss the pros and cons of each organizational form thoroughly and choose the best one for a sustainable community-based seed enterprise in their particular context.

Products, crops and varieties

Crop and variety choice is based on market demand, productivity, and suitability for different end uses, as well as suitability of the area for specific crops. Teff, wheat, maize and potato are dominant crops. However, wheat and teff are not profitable for the seed business. Since a seed production scheme is planned using irrigation, it is not worthwhile to produce low market value crops. Therefore, potato and hybrid maize were selected; these crops have high market demand and attractive prices. BH-540 is the most popular maize variety in the region, but due to low yield and a synchronization problem it is difficult to include it in seed production. Instead BH-660 was selected for its ease of production. Gera, Wochecha and Guasa varieties are selected for potato seed production. Pulses are included for rotation purposes only: farmers traditionally grow chickpea and grass pea after teff and wheat.

Production and marketing plans

A seed production plan for three years is prepared. During the project period, a total of 783 tons of raw seed will be produced, consisting of 158 tons of hybrid maize and 625 tons of potato seed (Table 6.4). After processing, a total of 642 tons of clean seed of hybrid maize and potato will be marketed in the project period. The current market situation is taken into consideration in determining the price. Although the ESE and/or other suppliers sell the seed at lower prices, farmers are obliged to buy hybrid maize for Birr 10 and potato for Birr 4.5 per kg, due to high demand in the area and neighbouring towns.

Financial plan

To undertake this project, an initial capital of Birr 500,000 is required. In the first year, the estimated revenue of Birr 688,000 will be generated from seed sales of 32 tons of maize seed and 100 tons of potato seed. The total production cost is expected to be

Birr 611,875. A net profit of Birr 1,434 and 303 will be achieved per ton of maize and potato respectively. This calculation does not include promotion costs (see also Table 6.5).

Table 6.4 Seed production and marketing plan of the Avola Goshiye community-based seed enterprise

<i>Crop</i>	<i>Raw seed produced (tons)</i>			<i>Cleaned seed (tons)</i>			<i>Selling price/ kg (Birr)</i>
	<i>2007</i>	<i>2008</i>	<i>2009</i>	<i>2007</i>	<i>2008</i>	<i>2009</i>	
Maize	35	53	70	31	47	63	9.00
Potato	125	250	250	100	200	200	4.00

Table 6.5 Income and expense budget of the Avola Goshiye community-based seed enterprise for 2007

<i>Income</i>	<i>Maize</i>	<i>Potato</i>	<i>Total</i>
Sales volume (tons seed sold)	32	100	132
Average selling price per ton seed	9,000	4,000	
Value of sales	288,000	400,000	688,000
Total cost of seed produced	169,275	311,500	480,775
Total overheads	72,850	58,250	131,100
Net profit	45,875	30,250	76,125
Gross margin per ton of seed sold	3,710	885	1,570
Net profit per ton of seed sold	1,434	303	577

Note: all amounts are in Birr (ETB).

Constraints and opportunities

Physical, socio-economic and technical constraints can be identified which limit agricultural development in general, and the seed sector in particular. The most important constraint is land fragmentation and population pressure: this means that a large number of farmers are required in order to produce enough seed. For example to produce seed on 15 ha, about 60 farmers with an average land holding of 0.25 ha are required. Moreover, it is difficult to cluster seed production fields. Declining natural resources (soil fertility and forest) threaten production and the long-term productivity of the farmland. Environmental fluctuations (flood, hail, unreliable rain fall) particularly affect rain-fed agriculture. Most improved seed supply is from research (the ESE or the BoARD), which only covers 12% of the total seed demand. There are no private companies engaged in the seed business, with the exception of some individual efforts. A loose regulatory system creates an insecure business environment. For example, underweight packs and expired fertilizers are sold to farmers by private suppliers and cooperatives. This causes farmers to distrust cooperatives, which potentially disadvantages seed enterprises operating as cooperatives. Local varieties may be preferred but still have a low productivity and may suffer from crop pests and diseases. Crop improvement programmes have paid little attention to traditional varieties and farmers criteria. Farmers lack awareness on

quality seed production, management and marketing systems. Finally, there is a shortage of initial basic seed for various crops (e.g. potato).

The following opportunities have been identified as creating a favourable environment for the establishment of a CBSE. Various stakeholders have shown their commitment (research, the ESE, BoARD cooperatives, cooperative agency) to supporting the enterprise and efforts to increase seed availability to farmers. Roads are improved, resulting in better market access. Development agents and a cooperative agency are present in the kebele and willing to support the enterprise. Capacity building institutions (university, agricultural colleges, and farmers training centres) are willing to support the initiative. A final opportunity is the existence of irrigation facilities that are available for seed production. Agricultural polices encourage the private sector.

Essential support and proposed follow-up activities

Various stakeholders contribute to establishing and operating the CBSE: cooperatives, research, the BoARD, the ESE, the cooperative agency and World Vision Ethiopia. Their roles and responsibilities are listed in Table 6.6. After establishing the enterprise, its structure needs to be finalized. Legal formalities among the member farmers need to be arranged, with the support of the cooperative agency. Basic initial seed, credit and other inputs need to be purchased and supplied, and land preparation and planting needs to be organized. Throughout the entire process, seed producer farmers and technicians participate in training and capacity building.

Table 6.6 Essential support required for the establishment of Avola Goshiye seed enterprise

<i>Stakeholder</i>	<i>Roles and responsibilities</i>
Cooperatives	<ul style="list-style-type: none"> • Provide facilities (store, office, credit) • Timely input supply • Support in seed marketing
Cooperative agency	<ul style="list-style-type: none"> • Organize farmers for CBSE • Develop organizational structure of the enterprise • Technical support and training
Research	<ul style="list-style-type: none"> • Provide basic seed of potato • Technical support and training • Storage facilities for potato seed
BoARD	<ul style="list-style-type: none"> • Lead and organize stakeholders for the pilot project • Provide technical support and credit • Training and quality control service
WoARD	<ul style="list-style-type: none"> • Site selection and awareness raising among farmers • Facilitation of input supply and training • Provide technical support • Monitoring the pilot project
ESE	<ul style="list-style-type: none"> • Provide parental line of hybrid maize BH-660 • Training and technical support on hybrid maize production
World vision	<ul style="list-style-type: none"> • Financial support

6.3 Erer Union Seed Producers and Marketing Cooperative, Gimbichu district, Oromia region*

Shemsu Baissa, Imiru Mijana, Eshetu Sisay, Demissie Mitiku, Ali Adem, Tadesse Wube and Zenebe W. Silase

It has been widely recognized that improved seed holds the key to enhanced farm productivity and better livelihoods. In spite of decades of efforts by the government, the private sector and donors to support seed availability and access in Ethiopia, the seed situation remains dismal. The formal seed sector, represented by the publicly owned Ethiopian Seed Enterprise and the private sector, has had considerable success in seed production and supply of hybrid maize and bread wheat varieties. However, the geographic coverage is limited in scope and only a few varieties are produced that have wider adaptation. The supply of seed for pulses is very low, while that of oilseeds, or seeds for vegetables, fruits, spices and forage is negligible.

Ethiopia's seven million smallholder farmers (with landholdings of 1-2 hectares) produce more than 95% of the total agricultural output. The established practice of farmers saving a portion of their harvest for planting the next crop (part of informal seed system) is dominant. This means that the informal system accounts for more than 95% of the seed supply in the country. In Ethiopia in general and in Oromia regional state in particular, awareness is growing, as is interest in helping the informal seed sector, enhancing its contribution to seed security, and establishing adequate links with the formal seed sector. The stronger and more inclusive national seed system that can be achieved in this way will make a significant contribution towards the attainment of food security at all levels.

Cognizant with the role of the informal seed sector in Ethiopia, the tailor-made training programme on supporting informal seed supply was implemented from October 2006 to October 2007. Seed experts representing different stakeholders at federal and regional levels, including those from the Oromia region, participated in this programme. After theoretical and practical sessions, one of the Oromia teams conducted a participatory seed system analysis and seed demand survey in Gimbichu district. This section focuses on the outcome of this analysis and the experiences with the establishment of a small-scale seed enterprise.

The seed supply situation in Gimbichu district

The participatory seed system diagnosis conducted at Seftu and Kersa community in Gimbichu district revealed that both the informal and formal seed systems are functional, while the informal system is dominant in the area. Farmers use their own saved seed for the production of most crops. The provision through the formal system of seeds of improved varieties of bread wheat, lentil and chickpea is part of an

* This section is an output of the Oromia Central East regional team participating in the ESE/WUR/ICARDA Tailor Made Training Programme on Revitalizing farmer-based seed production and supporting informal seed supply of local crops in Ethiopia, supported by Nuffic (The Netherlands).

extension programme supporting high input packages which has played an important role in increasing agricultural productivity and production. In spite of all the efforts undertaken by GOs and NGOs, availability of and access to seed of improved crop varieties still remains a major constraint. There is a need for a strategy that alleviates these problems. The establishment of small-scale seed enterprises is one of the strategies that can provide a solution.

Overview of the enterprise

The overall objective of the small-scale seed enterprise is to address availability of and access to seed of improved crop varieties at the village level to ensure food self sufficiency and improve the livelihood of the rural people. The specific objectives are: (i) to strengthen the capacity of farmers in seed production techniques; (ii) to build seed processing and storage facilities at village level; (iii) to produce and market quality seed; (iv) to conserve farmer varieties; (iv) to link the informal seed system with the formal system; (v) to create job opportunities for the farming community; and (vi) to increase the income of the farming community.

The enterprise is called Erer Union Small-scale Seed Enterprise. It will be established under the umbrella of Erer farmers' Cooperatives Union, which includes voluntarily cooperatives in four districts. The enterprise will take the form of a Seed Producers' and Marketing Cooperative (SPMC). The area of operation of the Union includes Gimbichu, Ade'a, Liban chukala and Akaki districts of East Shewa zone of Oromia region. The main purpose of the Union is to procure agricultural inputs and provide services to its members at a reasonable price. SPMC can contribute to overcoming shortages of improved seed, and other seed-related problems in the area.

It is agreed that the enterprise is to be located in Bishoftu town. Bishoftu is situated 46 km east of Addis Ababa, the capital of Ethiopia. It is the central town for the four districts in which the union is operating, and is therefore accessible.

Rainfed agriculture predominates in the Gimbichu district. The average farm size ranges from 2 to 3 hectares, with farmers allocating the available smallholding to different crops. Farmers in the study area use diversification as means of risk minimization. Because of these facts, the number of SPMC members is currently 323. As the seed production area increases, the number of farmers should increase accordingly, to secure enough land for subsequent seed production. The number of farmers required for the coming three years is indicated in Table 6.7

Table 6.7 Number of farmers required in establishing Erer Union Seed Producers' and Marketing Cooperative

<i>Crop</i>	<i>Average seed rate (kg/ ha)</i>	<i>Average farm area (ha)</i>	<i>Number of farmers</i>		
			2007	2008	2009
Wheat	150	1	67	121	133
Lentil	80	1	150	169	186
Chickpea	120	0.5	106	116	128
Total			323	2414	2456

Legal form and structure of the enterprise

In the regional context and prevailing situation, the legal form of the enterprise should be a Seed producers' and Marketing Cooperative. Cooperatives are tax-exempted and have access to credits and marketing services. The Cooperative Promotion Office provides assistance in organizing farmers and legalizing their entity as cooperatives, and provides free external auditing services. The agriculture and rural development office at district (woreda) level provides technical support for seed production and quality control. Three development agents are assigned to work with farmers at village level. A broad base of experience of establishing cooperatives in the district is available. Cooperatives functioning in the district include Hawi Boru Seed producers' and Cheffe donsa Local Crop Conservation Cooperatives, and Lemlem-Cheffe and Choba Seed Producers' and Farmers' Cooperatives.

The structure of an SPMC follows the legally established format for cooperatives; it includes a general assembly, an executive committee, a credit committee and an audit committee. The general assembly consists of all members of the cooperative. Each committee has three members (chairman, vice chairman and secretary) and all committee members are elected by the general assembly.

Crops and varieties selected for the business

The participatory seed system analysis identified bread wheat as the major crop grown in terms of area coverage. HAR 604 and HAR 1685 are the two most widely cultivated high yielding dwarf bread wheat varieties. Many farmers allocate a larger area of their landholding for the production of these two varieties. Lentil is the second dominant crop, and the most popular improved variety is called 'Alemaya'. During the participatory seed system analysis the farmers indicated a high demand for seed of improved crop varieties while seed supply hardly meets this demand. In general, there is a great seed demand of improved varieties of bread wheat, lentil and chickpea in the area. Therefore, the three crops are identified for starting a seed business. The seed system analysis revealed that farmers preferred the varieties 'HAR 604' (bread wheat), 'Alemaya' (lentil) and 'Arerti' (chickpea). 'HAR 604' covers the largest area and performs very well in terms of yield and quality. Of the released lentil varieties, 'Alemaya' is in highest demand in the market because of its yield potential. 'Arerti' is a Kabuli type chickpea with bigger seeds and better market demand than the desi types which have small seeds.

Production, marketing and financial plans

The production plan explains the requirements for producing the seed to be sold for the next three years. It is based on the demand survey which is part of the seed system analysis. The basic seed requirement for the same year has also been prepared. The Ethiopian Seed Enterprise needs to commit itself to supplying the SPMC with this quantity of basic seed. The production plan also includes the area requirement for the production of certified seed, the basic seed requirement and the area for certified seed production (Tables 6.8 and 6.9).

Table 6.8 Seed production plan (tons/year) and area required for Erer Union Seed Producers' and Marketing Cooperative for period 2007-2009

<i>Crop</i>	<i>Seed production (t/year)</i>			<i>Average farm yield (t/ha)</i>	<i>Seed grower price (Birr/t)</i>	<i>Area for seed production</i>		
	2007	2008	2009			2007	2008	2009
Wheat	200	726	799	3	3000	67	242	266
Lentil	230	253	278	1.5	5400	153	169	186
Chickpea	79	87	95	1.5	5520	53	58	64
Total						273	2477	2525

Table 6.9 Basic seed required (tons) by Erer Union Seed Producers' and Marketing Cooperative for the period 2007-2009

<i>Crop</i>	<i>Basic seed cost (Birr/t)</i>	<i>Basic seed required (tons)</i>		
		2007	2008	2009
Wheat	3520	10	36	40
Lentil	6600	12	14	15
Chickpea	6400	6	7	8

The first step in developing the business plan is to define the marketing strategy for achieving the business goal and selling the seed. This includes identifying, informing, and servicing customers, and making the actual sales. To create a broader and more sustainable market outlet, the Seed Producers' and Marketing Cooperative (as an enterprise) will be integrated into Erer Farmers' Cooperative Union. If there is any surplus certified seed, it can be sold to other districts in which the Union operates. In setting the seed price, the production cost, the grain price of the seed crop and the basic seed price of the Ethiopian Seed Enterprise are considered. The marketing plan of the enterprise is described in Table 6.10.

Table 6.10 Total seed sales plan (t/year) for the Erer Union Seed Producers' and Marketing Cooperative for the period 2007-2009

<i>Crop</i>	<i>Seed sold (tons/year)</i>			<i>Selling price/kg</i>
	2007	2008	2009	
Wheat	180	660	726	3.55
Lentil	200	220	242	6.90
Chickpea	75	823	91	6.70

The financial strategy brings the marketing and production strategies together in an income and expense budget to see if the plan is profitable, and works out schemes for financing, monitoring and evaluating the plan. The income and expense budget for the year 2007 is given in Table 6.11.

Table 6.11 Income and expense budget for the Erer Union Seed Producers' and Marketing Cooperative for 2007

	<i>Bread wheat</i>	<i>Lentil</i>	<i>Chicpea</i>	<i>Total</i>
<i>Income</i>				
Sales volume (t basic seed)	10	12.3	6.4	51.7
Average selling price/t seed	3,520	6,600	6,400	
Value of sales	35,200	81,180	40,960	157,340
Sales volume (t CSC1)	180	200	75	875
Average selling price/t seed	3,550	6,900	6,700	
Value of sales	639,000	1,380,000	502,500	2,521,500
Sales volume t/by-product	20	29.9	3.1	53
Average selling price t/by-product	2,000	3,000	3,000	
Value of sales	40,000	89,700	9,300	1,39,000
Total value of sales	714,200	1,550,880	511,875	2,776,955
<i>Expense</i>				
Quantity of seed purchased (t)	200	230	79	508
Seed purchase price (Birr/t)	3,000	5,400	5,520	
Total cost of raw seed (Birr)	600,000	1,242,000	434,976	2,276,976
Cost of basic seed	35,200	81,180	40,960	157,340
Processing costs	30,000	34,500	11,820	76,320
Packaging (bags)	10,800	17,200	3,942	31,942
Labour	12,000	13,800	4,728	30,528
Total cost of seed produced	688,000	1,388,680	496,426	2,573,106
Gross margin profit	26,200	162,200	15,449	203,849
<i>Overhead costs</i>				
Staff (inspectors)	24,480	8,280	3,240	36,000
Total overhead costs	24,480	8,280	3,240	36,000
Grand Total Cost	712,480	1,396,960	499,666	2,609,106
<i>Net profit</i>	<i>1720</i>	<i>153920</i>	<i>12209</i>	<i>167,849</i>
<i>Net profit percentage</i>		<i>11%</i>	<i>2%</i>	<i>6%</i>

Constraints and opportunities

There are some constraints on the implementation of this community-based seed enterprise configured as a seed producers' and marketing cooperative. The main constraints are: the shortage of basic seed, small landholdings, rigid seed certification standards, the limited availability of alternative improved crop varieties (e.g. lentil) and poor linkages among stakeholders.

Many opportunities exist for the successful establishment of the SPMC. The foremost opportunity is that farmers are willing to actively participate in seed business. Agricultural inputs, especially seed, are exempted from tax. There is a lot of demand among farmers for seed of improved crop varieties. Because of higher current grain price, farmers are in a better financial position to purchase seed for a reasonable price. Moreover, food processing factories and cottage industries are located in the vicinity of the SPMC, creating a favourable environment stimulating production. Grain export opportunities exist through farmers' cooperative unions. Good access to the capital

city and other towns such as Bishftu, Modjo and Adama also creates favourable conditions for establishing the enterprise.

Essential support and proposed follow-up activities

A successful SPMC requires financial support for working capital, seed processing machines and seed storage. To create awareness and build the capacity of the experts to implement the pilot programme in the plan year (2007/2008), various trainings were organized for zonal and woreda (district) experts and development agents. These trainings took place at Assela town over three consecutive days. Topics addressed were general seed multiplication principles; small-scale farmer-based seed production systems; field inspection procedures for self-pollinated crops; field inspection procedures for maize; seed sampling techniques and agricultural marketing. Focal personnel have been assigned to the two project sites to carry out activities pertinent to the pilot project at woreda and PA level. Seftu and Lemlem-cheffe peasant communities have been selected for the pilot project in Gimbichu woreda. A total of 206 model farmers experienced with the extension package and seed multiplication programme have been selected and trained in seed multiplication. The planting operation for the pilot programme was started in 2007. A total of 140 hectare of land has been covered with seed so far in the two communities in August 2007, including 95 ha with bread wheat and 45 ha with lentils.

As mentioned above, some activities had already been started at the moment of writing this section. Follow-up activities that should still be carried out include more technical operations such as planting, seed quality control, seed crop management, seed crop harvesting, seed testing and seed processing. Other more business-oriented operations include developing a logo, preparing packaging material with the logo on it, seed marketing, pilot programme evaluation, and looking for further funding to enforce and support an economically viable SMPC.

6.4 Wamura-Sako Small-scale Farmers Seed Producers' Group in Dendi woreda, central west Oromia region *

Messele Shimels, Assefa Senbeta, Hagos Gidey, Goshime Tekle, Fikre Mulugeta, Adugna Kefeni and Girma Chemedda

In Ethiopia, the agricultural sector is the main producer of food and the supplier of export products. It is also the largest sector providing employment in the country, with more than 80% of the population engaged in the sector. Crop production has the

* This section is an output of the Oromia Central West regional team participating in the ESE/WUR/ICARDA Tailor-Made Training Programme on Revitalizing farmer-based seed production and supporting informal seed supply of local crops in Ethiopia, supported by Nuffic (The Netherlands).

largest share and is predominately characterized by small-scale production. However, productivity remains at low levels, due mainly to low-level use of improved technologies like improved seed.

The use of improved seed in the country is very low and more than 90% of the seed planted annually is the farmers' own saved seed and seed exchanged among farmers. To increase crop production and productivity, it is very important to improve the quality of seed saved by farmers and to increase improved seed coverage.

Professionals of various relevant institutions at federal and regional levels including those from the Oromia region participated in the tailor-made training programme on developing mechanisms supporting farmer-based seed production and informal seed supply. One of the two regional teams from Oromia conducted a participatory seed system analysis and seed demand survey in the Dendi district. This paper presents a summary of the outcomes of the participatory seed system analysis and of the business plan for the establishment of a small-scale farmers' seed producer group as an option for strengthening local seed supply in this district.

The seed supply situation in Dendi district

Dendi woreda is located in central Ethiopia; its main town Ginchi is located 72 km west of Addis Ababa on the Addis-Ambo main road. The participatory seed system analysis was carried out in Olonkome and Wamura development sites (*yelimat tabiya*) which are important structures in the woreda. These sites have six and three kebeles respectively. Dendi woreda has a total area of 109,492 ha, of which 76% (71,681 ha) is cultivated, while the rest is occupied by grazing land, bush/forest land, villages, valleys, rivers, etc. The average farm size is 2.5 ha. Farmers at the two sites practise mixed farming, i.e. crop and livestock production. The main crops produced are cereals, pulses, oilseeds and spices. Specifically important crops are teff, barley and wheat, covering 28, 26 and 22% of the area under annual crops, respectively. Crop production is mainly performed during the main (*Meber*) season from mid-June to December/January. Farmers also practice double cropping.

The participatory seed system analysis conducted in Dendi woreda showed that the crops and varieties grown are highly diversified. Farmers listed 15 crops with 40 varieties. Teff is the most diverse with seven varieties, and chickpea is the second most diverse with five varieties. The majority of other crops each have two to three varieties, whereas grass pea and mustard each have one variety. Most varieties are identified as local varieties except for Kubsu (wheat), Shasho and Marye (chickpea), and Bh660 (maize), which are improved varieties. In many cases, farmers could not distinguish between improved and local crop varieties, either because the varieties were introduced a long time ago or because the seed was purchased from the local market. Examples include teff varieties like Magna, Golelisa, Qoledima, and a field pea variety named Nechi.

Assessment of the seed market

The major constraints in the seed market identified during the participatory seed system analysis are the shortage of seed of improved varieties of wheat, maize and chickpea; delayed supply of improved seeds; limited attention to the maintenance,

improvement, and production of local varieties resulting in the extinction of varieties; and the presence of few seed producers and distributors. The annual average crop areas for 2003-2005 indicate that teff, wheat and barley cover more than 75% of the area. Maize, chickpea and lentil occupied only 4%, 3% and 1%. Thus, the woreda is considered a potential seed market for these crops. The six crops occupying 82% of the area have a theoretical seed requirement of 61,260 quintals each year, computed based on theoretical seeding rate. When considering seed production in woina dega agro-climatic zone (e.g. Wamura), the assessment of the potential seed demand was based on only 72% of the crop area. Based on these assumptions any seed producer for these crops will have a potential demand of 31,749 quintals with an estimated market value of 10.64 million Birr in Dendi woreda. The potential demand and market value of each crop is presented in Table 6.12.

Table 6.12 Potential seed demand of major crops grown in Dendi woreda

<i>Crop</i>	<i>Average crop area (ha)</i>	<i>Seed rate (qt/ha)</i>	<i>Total seed needed (qt)</i>	<i>ESE current price (Birr/qt)</i>	<i>Potential market value (Birr)</i>
Teff	15,804	0.3	4,741	324	1,536,195
Wheat	13,221	1.5	19,832	260	5,156,237
Chick pea	2,135	1.2	2,562	385	986,524
Maize	3,303	1.2	3,964	650	2,576,600
Lentil	541	1.2	649	600	389,520
Total	35,005		31,749		10,645,076

Source: Woreda agricultural office, ESE and Computation.

According to the woreda agricultural office, on average 4,627 ha (6%) is covered with improved seed, including the area planted with recycled seed. The remaining 94% of the area is covered with seed obtained from own saved seed, the local market or farmers' seed exchange. The improved seed coverage is even lower in the five kebeles surveyed for the study, i.e. of the 6,286 ha, only 130 ha (2%) is covered with improved seed of teff, wheat and maize crops. To be realistic, the figures for potential demand were lowered in line with farmers' assumed seed replacement rate. Taking three years' seed replacement, the annual demand in the area is estimated to be 10,500 tons.

Overview of the enterprise

Farmers in Wamura Sako and Werka Warebu peasant associations were encouraged to establish the Wamura-Sako Small-scale Farmers Seed Producer Group, which will undertake seed production and marketing, primarily for the Wamura development site, neighbouring farmers, and farmers in adjacent woredas. The objectives of the Wamura-Sako Small-scale Farmers Seed Producer group are to ensure an adequate and timely supply of quality seed of improved and local varieties by producing, processing and distributing the seed; to contribute to the conservation of local varieties by producing and organizing diversity fairs in collaboration with pertinent bodies like the IBC; and to make a reasonable profit from the sales of improved and local seed varieties. Its proposed legal basis is based on the cooperatives law.

Crop and varieties identified

The results of the participatory seed system analysis and seed demand survey are used to identify crops and varieties. A number of criteria were used, including the annual crop area (number of beneficiaries and market potential), the suitability and profitability of the crops, the seed demand and availability of local crop varieties, production technology and management requirement levels of crops, results of prioritizing crop varieties, experiences of farmers in producing crops, and farmers' opinions on the plan. Table 6.13 summarizes the proposals on the type of crops and varieties to be included in the portfolio of the seed producers' group.

Table 6.13 Crops and varieties selected for seed business for Wamura-Sako Small-scale Farmers Seed Producer Group, Dendi woreda

<i>Crops</i>	<i>Varieties</i>	<i>Improved/local</i>
Teff	Magna	Local and improved
Wheat	Kubsa (HAR 1685), Tikur sinde	Improved and local
Chickpea	Missire, Shasho	Local
Lentil	Alemaya	Improved

Production, marketing and financial plan

To meet its sales targets, the seed group will start producing seed on 200 ha of land owned by members in the first year, and expand to 331 and 422 ha in the second and third years. To allow expansion of the area, the group will contract neighbouring farmers. The quantities of raw seed produced, and the estimated yield per hectare are summarized in Table 6.14.

Table 6.14 Area, yield and raw seed production for Wamura-Sako Small-scale Farmers Seed Producer Group, Dendi woreda

<i>Crops</i>	<i>2008/09</i>			<i>2009/10</i>			<i>2010/11</i>		
	<i>Area (ha)</i>	<i>Yield (q/ha)</i>	<i>Raw seed (q)</i>	<i>Area (ha)</i>	<i>Yield (q/ha)</i>	<i>Raw seed (q)</i>	<i>Area (ha)</i>	<i>Yield (q/ha)</i>	<i>Raw seed (q)</i>
Teff	88	10	876	88	13	1,156	88	14	1,232
Wheat	70	25	1,750	70	35	2,450	70	35	2,450
Chickpea	32	14	452	32	16	512	32	16	512
Lentil	10	8	76	10	10	100	10	10	100
Total	200		3,154	200		4,218	200		4,294

The raw seed purchased from farmers is collected and cleaned to maintain quality. The cleaned seed is sold to customers at a price with minimum profit margins. The seed group will produce and sell approximately 2600, 3100, and 3900 quintals of local and improved varieties of teff, wheat, chickpea and lentil seed, which will cover 16%, 22%, and 27% of the current estimated potential market for the years 2008/09, 2009/01 and 2010/11 respectively. The planned amounts of seed sold and prices are presented in Table 6.15.

Table 6.15 Quantity of seed sold, price and total revenue in 2008/9, 2009/10 and 2010/11

<i>Crop</i>	<i>2008/09</i>			<i>2009/10</i>			<i>2010/11</i>		
	<i>Seed sales</i>	<i>Selling price</i>	<i>Total revenue</i>	<i>Seed sales</i>	<i>Selling price</i>	<i>Total revenue</i>	<i>Seed sales</i>	<i>Selling price</i>	<i>Total revenue</i>
Teff	701	629	441	468	619	289	585	616	360
Wheat	1,487	375	557	2,249	373	840	2,738	396	1,084
Chickpea	384	581	223	320	570	183	449	605	271
Lentil	65	632	41	81	622	50	130	657	85
Total	2,637		1,263	3,117		1,362	3901		1,801

Note: Seed sales in quintals; selling price in Birr/quintal; total revenue * 1000 Birr.

For each crop, the total cost of production (direct and indirect) is estimated for the three years. Annual seed sales, selling price, revenues, production costs and profits were analysed for three years. The summary of the financial plan and the profitability is presented in Table 6.16.

Table 6.16 Summary of the financial analysis for 2008/9, 2009/10 and 2010/11

<i>Description</i>	<i>2008/2009</i>				
	<i>Teff</i>	<i>Wheat</i>	<i>Chick pea</i>	<i>Lentil</i>	<i>Total</i>
Seed sales (q)	701	1,487	384	65	2,637
Total revenue (Birr)	471,398	589,860	234,027	43,283	1,338,568
Total cost (Birr)	461,619	571,742	224,686	41,724	1,299,770
Net profit before tax (Birr)	9,779	18,119	9,341	1,559	38,798
Total cost (Birr/q)	659	384	585	642	493
	<i>2009/2010</i>				
Seed sales (q)	468	2,249	320	81	3,117
Total revenue (Birr)	329,825	937,882	200,525	55,966	1,524,198
Total cost (Birr)	316,049	897,900	191,834	53,565	1,459,348
Net profit before tax (Birr)	13,775	39,982	8,691	2,401	64,849
Total cost (Birr/q)	676	399	599	661	468
	<i>2010/2011</i>				
Seed sales (q)	585	2,738	449	130	3,901
Total revenue (Birr)	410,832	1,203,067	296,860	94,334	2,005,093
Total cost (Birr)	393,678	1,151,470	283,934	90,267	1,919,349
Net profit before tax (Birr)	17,154	51,596	12,926	4,068	85,744
Total cost (Birr/q)	674	421	633	694	492

Essential support and proposed follow up activities

The profit and loss analysis shows that the seed producers' group is profitable. However, initially the pilot project requires various types of support. This is necessary since the implementation requires the involvement of many farmers who do not have the same level of awareness, experience and knowledge of running a seed business. Initial support is required for coordination, financing, training, extension and technical issues. The implementation of the proposed seed producers' group was scheduled to start from August 2007. The establishment of the group could be guided by experience gained from some activities undertaken at the proposed seed production sites as part of the regional seed multiplication programme.

6.5 Wamole farmers' cooperative for maize seed production in Boricha woreda, SNNPR*

Tesfaye Tadesse, Tefera Zeray, Mata Gedebo, Abebe Tilahu and Solomon Benor

Agriculture is the major economic activity in the Southern Nations, Nationalities and Peoples' Region (SNNPR) of Ethiopia. However, the performance of the agricultural sector lags behind, despite the rapidly growing population and increased demand for food and feed. The most important constraints are the few available improved varieties, limited access to seed, and the untimely supply of seeds and other agricultural inputs. Several farming systems are practised in the regions within various agro-climatic zones. Mixed farming (crop and livestock), large-scale commercial farming and pastoral farming are prevalent. The majority of farmers (94%) are engaged in mixed farming. Major crops include maize, wheat, teff, barley, sorghum, coffee and enset. To assess the extent of seed supply and local knowledge on seed management, and to establish a small-scale seed enterprise, a participatory seed system analysis and a seed demand survey were conducted in selected kebeles, i.e. Guana Bulano and Fulasa Aldada in Boricha. Data from the Woreda Office of Agriculture indicated that about 37,500 hectares are cultivated in the area. Haricot bean is grown as relay cropping. Farmers leave haricot bean in the field while harvesting the maize crop and allow it to grow to full maturity before harvesting it. This practice results in the area covered with haricot bean being very similar to that of maize. Out of the total area cultivated, the share for maize and haricot bean was 38% and 37%, respectively. Following maize and haricot bean, enset accounts for 21%, demonstrating the importance of this crop as the area's staple food.

* This section is an output of SNNPR (South) regional team participating in the ESE/WUR/ICARDA Tailor-Made Training Programme on Revitalizing the farmer-based seed production and supporting informal seed supply of local crops in Ethiopia, supported by Nuffic (The Netherlands).

The seed supply situation in Boricha district

A participatory seed system analysis and a demand survey were conducted in two target communities, Gonuwa Bulano and Fulasa Aldada. The results characterize the areas by recurrent drought, high population density, strong farmers' demand for improved seed, low supply of improved seeds, and little attention to the informal seed system, especially to local variety maintenance. Both the formal and informal seed systems are seed sources for farmers. The informal sector is the main supplier of seed for crops and local varieties like enset, haricot bean, potato, and sweet potato. The seed of local crops and varieties is obtained from farm-saved seed, the local market, relatives and neighbours. Among these, farm-saved seed and seed from local grain markets are major sources (Table 6.17). The formal sector is responsible for seed supply of maize hybrids and some of the supply of haricot bean varieties (Table 6.17). Various stakeholders act as direct or indirect seed sources. They include the Bureau of Agriculture and Rural Development (BoARD), the Ethiopian Seed Enterprise (ESE), the agricultural research centre, local and international NGOs, local markets and churches. The ESE and NGOs supply improved seeds through the Woreda Agriculture Office. Through the BoARD, the ESE plays a major role as a source of improved maize varieties (BH-540 and BH-140).

Table 6.17 Seed source and frequency of purchase in Boricha woreda

<i>Source</i>	<i>Crop</i>	<i>Type</i>	<i>Frequency</i>
Self maintained	Enset Haricot bean Maize	Local	
BoARD	Maize Haricot bean	Improved	Every year Occasional
Relatives	Enset	Local	Occasional
Local market	Haricot bean Teff	Local	Occasional
Churches	Haricot bean	Improved	Occasional (gift)
NGOs	Haricot bean	Improved	Gift through BoARD

Although the formal system is operating in the area, seed demand for improved varieties is not yet satisfied. Thus it is important to establish a small-scale seed enterprise in the area. However, such an effort needs to overcome many barriers. These include fragmented land holdings and the consequent difficulties in maintaining minimum isolation distance; this is particularly relevant to hybrid maize seed production. Other limitations are insecure rainfall patterns and the lack of irrigation facilities. Therefore, the team selected an existing cooperative, Wamole irrigation cooperative, in the nearby woreda of Shebedino as the basis for a small-scale seed enterprise. Upon analysis of the market demand and profitability of seed production, the team supporting the cooperative seed production pilot project recommended starting with the production of seed of the maize hybrid variety BH-540.

Overview of the enterprise

The objective of the small-scale seed enterprise is to supply seed of improved varieties, to increase farmers' income through seed production, to improve the livelihood of the farmers and thereby to contribute to food security at the house level. The seed production activities within the Wamole irrigation cooperative involved 40 farmers and covered 20 ha. The cooperative's potential for seed production was estimated at 40 ha and 150 seed producing farmers. The cooperative has been legally established and licensed according to the rules and regulations of the country. It is led by a chairman and secretary elected from among the member farmers, and a clerk. The cooperative was basically established to produce high value crops such as vegetables using irrigation facilities.

Production, marketing and financial plan

The enterprise was expected to produce 33 tons of maize hybrid seed of variety BH-540. A total area of 21 ha was obtained, involving 168 farmers with 0.5 ha of individual landholding in the production. 0.5 ton of basic seed was used for the total area; seed was obtained from the Bako Agricultural Research Centre with the costs of Birr 78,000 covered in cash. Assuming a processing loss of 10%, an estimated 30 tons of hybrid maize (BH-540) was expected to be sold in the year 2007 at a market price of Birr 8/kg of seed, which is equivalent to Birr 8000/ton (Table 6.18). It was planned to sell the product to the farmers in both the producing woreda (Shebedino) and the neighbouring woreda (Boricha), but the final price would depend on farmers' seed demands and market prices at the time of selling. If more than the expected yield was obtained, that surplus would be transported to Awassa and sold at the regional market.

Table 6.18 Cost of seed production and expected income calculated for hybrid maize seed production by Wamole farmers' cooperative in Boricha woreda

<i>Income</i>	<i>Total</i>
Sells volume (tons seeds sold)	30
Average selling price per t of seed	8,000
Volume of sells	240,000
<i>Expenses</i>	
Cost of basic seed	78,000
Processing costs	12,000
Seed dressing	3,745
Packaging (bags)	4,800
Total cost of seed produced	98,545
Gross margin/profit	141,455
<i>Overheads</i>	
Marketing costs	2,000
Total overheads	2,000
Total cost	143,455
Net profit	96,545

Note: all amounts are in Birr.

It was planned to spend a total sum of Birr 143,455 on basic seed purchase, seed processing, seed dressing, packaging/bagging and marketing. The money was obtained from Sidama Development Agency as a loan from a revolving fund. Sales amounting to Birr 240,000 were expected (Table 6.18). It was expected that 44 farmers would increase their income by selling improved maize hybrid seed, and the seed shortages of about 240 farmers would be solved. A net income of 96,545 Birr was estimated for the enterprise (Table 6.18).

Constraints, challenges and opportunities

The following constraints have been identified: land shortage and fragmented land holding, breeder seed shortage and high prices. Under field conditions, the basic seed of BH-540 has shown a decline in performance, typical for inbred lines. Consequently, farmers raised their fears for the success of the hybrid seed production enterprise within their cooperative. Efforts have been made to address the farmers' interest through the woreda structure. It is obvious that the performance of the male parent was poorer than that of the female parent. In some parts of the field, the growth of the male parent was retarded, plants being poorly established. Consequently synchronization between the male and female parents was difficult. However, with the consultative support of the ESE seed agronomists, the woreda, zone and regional BoARD agronomists did their best to improve the existing conditions by encouraging farmers to apply urea and carry out the required agronomic management practices. The woreda BoARD assigned an irrigation agronomist with a motorcycle to follow up the overall work. The stakeholders became very concerned about the success of the enterprise. The team tried to get support from the fund of the rural development capacity building programme to give the farmers further training in hybrid seed production. However, the nature of the chosen variety proved problematic. The team feared a pollen shortage, and their fears proved well-founded at the flowering stage. As a result, the entire exercise turned out to be a disappointment for the farmers, the cooperative, the stakeholders and the team. An important lesson to be learned is to initiate commercial seed production with a simple crop and only gradually move to more complex crops or even to hybrid seed production. One might even question whether hybrid maize seed production is a viable exercise on the scale of small-scale or community-based seed production. It is a complex matter, requiring several years of experience in seed production on the part of the farmers and support services involved.

Several opportunities can be identified on the basis of these experiences. The participatory seed system analysis and demand survey indicated a high seed demand at both local and regional level, suggesting opportunities for community-based and small-scale seed enterprises. Based on the limited availability and high demand, the price for hybrid maize seed is really high. For seed production in this region, it is favourable to work in those areas where irrigation facilities are available, as they allow for cultivation for seed production in the off season, offer sufficient areas for viable amounts of seed, and make it possible to isolate crops. Coupled with fertile land, this creates favourable conditions for seed production. Another plus over the past years has been the increasing grain price that leads farmers to look for quality seeds. A final

positive condition for the establishment of the seed enterprise in Boricha woreda is the close proximity to the woreda/regional market.

For successfully setting up a seed enterprise, the cooperative will require further technical backup and regular field monitoring, and access to market information. Since it is a cooperative, access to credit will not be complicated. Credit could be used to purchase inputs or threshing and processing machineries. Finally, the experience with hybrid maize seed production demonstrates the great need for training in seed production, processing and marketing.

Proposed follow-up activities, including regular follow-up by the research centre and BoARD experts, will define future and viable activities in seed production. The organizations, including the ESE, should provide further technical support on seed management, assist in the identification of existing and potential seed markets, and support the installation of small-scale processing machines.

Possible interventions of stakeholders such as NGOs, the regional agricultural and rural development bureaus, research institutes, universities, churches and local organizations acting in the region and woreda can obviously mitigate the seed shortage that farmers are currently facing. Policy changes might improve the current seed supply situation in the area, and in the region as a whole. Initiation of establishment of small-scale enterprises by individuals, farmer groups, cooperatives, private investors and/or social organizations has great potential to satisfy farmers' seed demands and contribute to the conservation of local/minor crops and varieties. However, the technology should not be the challenge, as happened with the BH-540 hybrid variety, leading to failure, as we have seen in the field. Even if a variety is in great demand, which was the basis for our selection of this variety, the challenge is to identify the right match between the technology, the capacity of the farmers and the enterprise, and the market demand.

6.6 Felegeweni and Mekan community-based seed enterprises in Atsibi Womberta and Endamehoni districts, Tigray region*

Tadese Teweldebrhan, Beyene Dimitsu, Muez Teare and Woldehawariat Assefa

Agricultural development remains the main strategy for improving the wellbeing of the majority of people in the Tigray region, northern Ethiopia. In Ethiopia in general, and in the Tigray region in particular, seed security underpins food security. According

* This section is an output of the Tigray regional team participating in the ESE/WUR/ICARDA Tailor-Made Training Programme on Revitalizing the farmer-based seed production and supporting informal seed supply of local crops in Ethiopia, supported by Nuffic (The Netherlands).

to the Bureau of Agriculture and Rural Development (BoARD), of the total cultivated land of 1.04 million ha, only 150,000 to 200,000 ha (15-20%) is estimated to be covered by improved varieties. The formal seed sector plays a role, especially in more accessible areas and for crops mainly distributed by the Ethiopian Seed Enterprise (ESE).

While more than 20 field crops and many local landraces are grown by farmers, improved varieties that are adapted to the agro-ecologic conditions of the region, and are distributed by the formal sector, are available for only a few crops such as wheat, teff, sorghum, field pea and lentil. Despite strong demand, there is a shortage of seed of even this limited number of varieties. The ESE and the BoARD are the main formal sector sources of for improved varieties where seeds are produced on farmers' fields on a contract basis, or brought from other parts of the country for local distribution. This incurs financial losses and entails logistic, administrative, and other associated problems. The major stakeholders in the formal seed system are Tigray Agricultural Research Institute (TARI), Mekelle University, the ESE, the BoARD and NGOs, which assist the formal/informal seed system or directly distribute seed themselves. Rest, Irish Aid, World Vision, IPMS/ILRI, Orthodox Church, Action Aid and Catholic Relief Services (CRS) are some of the NGOs involved in seed supply in the region.

The informal seed sector is predominant in the region and provides up to 80-85% of the seed produced annually for all crops. The share is expected to be higher if we include the exchange of improved seed through the informal seed system. The system is also responsible for the maintenance of genetic diversity, especially of major crops like barley, sorghum, wheat and teff. The informal seed system, although covering most of the seed demand, has its own major problems:

1. It is not properly linked to the formal seed sector so that farmers can get easy access to modern released varieties. The average yield of local wheat landraces is about 1.4 tons/ha, while a modern wheat variety yields 3 tons/ha. Similarly, legume yields could double from 0.8 to 1.6 tons/ha by using modern varieties.
2. Farmers do not differentiate between seed and grain during production. This results in problems associated with seed quality, such as seed-borne diseases, weed infestation, etc., which have a significant effect on productivity.

Seed experts representing the ESE-Mekele, the TARI, and the Tigray BoARD participated in the tailor-made training programme supporting informal seed supply in Ethiopia from October 2006 to October 2007. Upon initial training, the Tigray team conducted a participatory seed system analysis and seed demand survey in two districts in Tigray. This section focuses on the outcome of the participatory seed system analysis as conducted in November – December 2006, which forms a basis for the establishment of two community-based seed enterprises (CBSEs) in Atsibi Womberta and Endamehoni districts.

The seed supply situation in Atsibi Womberta and Endamehoni districts

In the first study area, Atsibi Womberta district (Felegeweini Peasant Association) the informal seed system is dominant, and is indeed the only seed source for barley – a staple food crop used for the preparation of different traditional dishes in the district.

The informal seed system is therefore responsible for the maintenance of barley diversity in the study area. Similarly, the informal system is important for the maintenance and sustainable use of other food crops such as wheat, faba bean, lentil, field pea, potato, and other minor crops. The formal seed system is also active to a very limited extent. The only crop handled by the formal system is wheat (a major crop after barley), and only two varieties are distributed, while more than ten wheat local land races are cultivated in the study area. In the 2003/04 and 2004/05 cropping seasons, the ESE worked with the BoARD on the on-farm seed multiplication of wheat and field pea. In addition some crop varieties such as faba bean, field pea, wheat and potato are being demonstrated by Mekelle Research Centre.

In the second study area, Endamehoni district (Mekan Peasant Association) both the informal and formal seed systems are functional. The formal seed system is dominant for crops like wheat, field pea and faba bean, as the agro-ecology is highly suitable for these crops and high demand exists for seeds. The area has relatively dependable rainfall and the ESE and the OoARD (Office of Agricultural and Rural Development) have experience with farmer-based seed production, so that the site could serve as a seed source to the neighbouring woredas and region at large.

Overview of the enterprise

The objective of the CBSE is to ensure improved availability of and access to seeds and varieties by farmers, and to enhance the performance of the informal sector in generating income and improving the livelihood of resource-poor farmers. In the Tigray region we have established two enterprises named Felegeweini Community-based Seed Enterprise and Mekan Community-based Seed Enterprise, which are located in the Atsibi Womberta district and Endamehoni districts, respectively. The Felegeweini CBSE has 35 member farmers and 5 ha irrigable land to produce potato, while the Mekan CBSE has 248 member farmers and 50 ha rain-fed land to produce wheat and field pea. The number of farmers and the area may increase over the years depending on the seed demand. The structure of both seed enterprises follows the legally established format for cooperatives.

Crops and varieties selected for the business

From the results of the participatory seed analysis, we learnt the following about the Atsibi Womberta district (Felegeweini PA):

- The farming system in the study area is based on cereal production (barley);
- With a few exceptions of wheat and legume varieties which are under demonstration, the formal seed system did not have much to offer in terms of good varieties of traditional crops (barley, wheat and legumes);
- Farmers at the woreda in general and the study site in particular have generations-old experience of producing and maintaining seed of their own varieties, hence there is little opportunity of making a profit by selling seeds of local varieties which are self-pollinated crops;
- Although Atsbi woreda is not a traditionally potato producing area, the TARI, the Holeta Agricultural Research Centre and the BoARD have identified the woreda

as one of the locations for potato seed production because of its agro-ecological suitability, and they started identifying varieties that are adapted to the locality.

From the participatory seed analysis, we learnt the following about the Endamehoni district (Mekan PA):

- The woreda has potential for crop production and huge demand for seed of improved varieties among farmers, and thus presents an opportunity for small-scale seed enterprises to engage themselves in seed production and marketing;
- Endamehoni has a suitable agro-ecology for wheat and field pea production, for which a high seed demand exists;
- Endamehoni could serve as a seed source to the neighbouring woredas and the region at large;
- The ESE and the OoARD do have experience of farmer-based seed production in this district.

In view of these facts, the study team decided to choose potato for the establishment of a CBSE in the Atsibi Womberta district (Felegeweini PA), and wheat and field pea in Endamehoni district (Mekan PA). For potato, the programme included the Tolcha and Jalení varieties, which give high yields and are preferred by farmers in the study area. For wheat varieties, HAR-2501 and Tegegnech were selected on the basis of farmers' preferences because of the following characteristics: specific adaptation, high yield, earliness and high market price.

Seed production, marketing and financial plans

To design a realistic and accurate marketing plan we have gathered information from all possible sources available in the study areas and neighbouring districts. We prepared questionnaires for seed producers, potential seed buyers, and the OoARD of six districts. Professionals from World Vision/Ethiopia, IPMS/ILRI, and the millennium development goal project were also interviewed. For both seed enterprises, Felegeweini and Mekan, the production plan was prepared for five years.

Based on the seed production plan, 817 tons of potato, 1,666 tons of wheat, 553 tons of field pea, i.e. a total 3036 tons of raw seed will be produced in the project period (Table 6.19). Based on the marketing plan, 735 tons of potato, 1500 tons of wheat and 500 tons of field pea, i.e. a total 2735 tons of cleaned seed, will be sold to customers at a price with minimum profit margins in both seed enterprises (Table 6.19).

Table 6.19 Estimated seed production and estimated seed sales (tons/year) of the Felegeweini and the Mekan community-based seed enterprise

<i>Felegeweini CBSE</i>	<i>2007</i>	<i>2008</i>	<i>2009</i>	<i>2010</i>	<i>2011</i>	<i>Total</i>
Potato seed production	50	100	167	222	278	817
Potato seed sales ¹	45	90	150	200	250	735
<i>Mekan CBSE</i>						
Wheat seed production	222	278	333	389	444	1666
Field pea seed production		66	110	155	222	553
Wheat seed sales ²	200	250	300	350	400	1500
Field pea seed sales		60	100	140	200	500

Notes: ¹ Selling price of 4.00 Birr/kg; ² Selling price of 3.25 Birr/kg.

The financial plans of both seed enterprises are based on the production plan and marketing plan, taking into consideration future needs for operation and expansion, the amount of seed sold and the selling prices. These are determined in such a way as to generate the income and profit required for the company to stay in business. See the details in Table 6.20.

Table 6.20 Income and expense budget for Felegeweini and the Mekan community-based seed enterprise for 2007

	<i>Felegeweini CBSE Potato</i>	<i>Mekan CBSE Wheat</i>
<i>Income</i>		
Sales volume (t basic seed)	45	200
Average selling price/t seed	4,000	3,250
Value of sales	180,000	650,000
Cost of basic seed	20,000	39,000
Processing costs		52,000
Packaging (bags)	15,000	4,000
Labour	3,150	84,000
Total cost of seed produced	38,150	179,000
Gross margin profit	141,850	471,000
<i>Overhead costs</i>		
Staff (inspectors)	2,602	9,398
Administration costs	651	2,349
Total overhead costs	3,253	11,747
<i>Net profit</i>	<i>138,597</i>	<i>459,253</i>
<i>Gross margin per t of seed sold</i>	<i>3,152</i>	<i>2,355</i>
<i>Net profit per t of seed sold</i>	<i>3080</i>	<i>2296</i>

Constraints and opportunities

Constraints that have been identified in the implementation of the CBSE are:

- Lack of knowledge and awareness among farmers on seed production and marketing; farmers do not make special arrangements in terms of land selection,

isolation or the various agronomic practices for seed production. Generally farmers practice plant (mass) selection at the time of maturity just before harvesting. Awareness-raising and training in seed production and marketing is needed;

- A basic seed supply that is inadequate for initiating farmer-based seed production and marketing;
- Land fragmentation and small landholdings, which make it difficult to keep the required isolation distances and cluster the plots;
- The fragile and high risk environment because of erratic rain and recurrent drought;
- Poor infrastructure.

Opportunities that have been identified in the implementation of the CBSE are:

- The presence of high seed demand for potato, wheat and field pea: selected sites could serve as a seed source to the neighbouring woredas and the region at large;
- The presences of strong national and regional initiatives in seed production;
- Willingness and commitment among stakeholders;
- The presence of development agents at kebele level and a cooperative division at district level;
- The presence of irrigation facilities for seed production: there is more than 1800 ha of irrigated land, of which more than 300 ha of land is covered by potato every year.

Essential support and proposed follow-up activities

Seed producer groups have to be organized in appropriate legal forms depending on the localities and commodities to be handled. Assistance and support needs to be provided to the CBSEs that will be established at pilot areas and then scaled-up to the regional level. The assistance required includes:

- Credit and input provision to make available pre-basic/basic seed and all inputs for seed production;
- Credit facilities for seed, using farmers to purchase inputs for grain production;
- Market promotion and information exchange, by assessing the seed market and creating market linkages;
- The provision of critical infrastructure;
- The provision of technical support.

7 Creating enabling policy frameworks for supporting informal seed supply

7.1 Seed policies: enabling support to informal seed systems

Niels P. Louwaars and Johannes M.M. Engels

Conventional seed policies

The green revolution and the introduction of the formal seed sector in many developing countries created specific roles for government in seed provision. This resulted in the need to develop policies that guide and support such developments and the investments they entail, and underpin the regulatory frameworks required for implementation.

Several countries have developed formal seed policies, most of which are based on the seed system development pathway.¹⁴³ This pathway identifies the consecutive development stages of seed systems from traditional farmer-production of seed to a commercially operating seed sector. During the initial stage of this pathway, the role of the government is to initiate components of the seed chain, and in the final stage it is to create conducive environments, through legislation in particular, for their further development, integration and privatization. Examples include government investments in the creation of public organizations for scientific plant breeding, public seed production and seed certification systems. Key regulatory frameworks to support the seed sector are seed laws, (more recently) intellectual property rights, and various forms of investment regulation.

The basic idea behind such policies is that farmers' use of 'quality seed' of 'improved varieties' is an important aspect of improving national food security and rural development. From this point of view, the term 'quality seed' is implicitly reserved for tested seed produced in the formal sector; 'improved varieties' are only those that result from scientific plant breeding. Most seed policies include goals for the modernization of seed use, such as 'all farmers should use quality seed' or a target replacement rate of four, which means that the formal seed sector should produce 25% of the national seed needs. At some stage, such policies focus on the liberalization of the seed sector, whether by restructuring the public seed company to become profitable (Egypt, Ethiopia), privatization by selling the public company (Malawi), or stimulating investments by local and/or foreign companies in competition with the public sector (Uganda).

Shortcomings of the conventional approach

The focus on the seed sector development pathway has one major shortcoming: it concentrates exclusively on the formal seed sector, and in doing so, it bypasses by far the largest seed supplier – the farmers themselves. This might not be a problem if these policies did not create obstacles to the functioning and development of farmers' seed systems. But they do. Although the informal sector is the major seed supplier there is lack of investments in improving the quality of farmers' seeds.* Worse still, when such policies are translated into seed laws, the obstacles posed by the formal system can be much more severe, depending on the wording of key clauses in these laws.¹⁴⁴

Seed certification rules may ban the production and marketing of farmer-produced seeds; some seed laws formally prohibit the key component of the informal seed system, which is barter of seeds among farmers. Seed laws also create significant bottlenecks for the development of community-based and small seed enterprises that may have to abide by all the complex and expensive regulations. Rules for variety release commonly reduce the number of varieties that are available to farmers, and often select varieties that are not optimally adapted to the conditions of the majority of farmers. Finally, the formal committees that are commonly put in place by such laws do not provide for good representation of the farmers' interests.¹⁴⁵ This means that conventional seed policies not only fail to support the diversity of initiatives that are discussed in this book, but may even hinder them.

Recent pressures on seed policies

Conventional seed policies are basically national in character, even though their development and formulation has often been donor-influenced. Recent developments in international law and bilateral negotiations, however, now affect the policy space within which national governments can operate, in terms of their seed policies. Such international agreements are largely external to the seed sector or even to agriculture. The trade sector developed the Agreement on Trade Related Aspects of Intellectual Property Rights (TRIPS-1994), which has one article that specifically addresses rights on crop varieties. The environmental sector developed the Convention on Biological Diversity (CBD-1993), which affects seeds as carriers of genetic information.

Intellectual property rights (IPRs) affect seed systems in that plant breeders may have to guard against using proprietary technologies and materials. They must have the institutional capacity to negotiate access to such technologies, and to guard against subsequent 'misuse' in later stages of the breeding and seed production process. Secondly, policies have to be developed for the use of IPRs by public research institutes, particularly to balance the promise of income from their research products – particularly varieties – against the risk of deviating from development objectives as a result of that promise.¹⁴⁶ IPRs can, however, be quite compatible with conventional seed policies. If well designed, these property rights systems can play a role in supporting the latter stages of the formal seed system development pathway.

* Walter de Boef and Zewdie Bishaw provide a more elaborate description of formal and informal seed systems in Section 1.3

The development of plant breeders' rights, specifically designed for the protection of plant varieties, is aimed at reducing problems that may arise from applying the patent system. However, the system which is currently in operation in most industrialized countries (the 1991 UPOV Act) is not geared to supporting the farmers' seed system and various types of integration between the formal and farmers' systems.¹⁴⁷ Even though TRIPS allows for a wide range of interpretation with regard to the protection of crop varieties, many developing countries now face pressure from bilateral trade negotiations with the USA and the EU to adhere to this UPOV system. Calls for development- rather than trade-related approaches to intellectual property rights (dubbed 'DRIPS')¹⁴⁸ relate less often to agricultural IPRs than to those for proprietary drugs (notably for HIV-AIDS).

Biodiversity policies based on the CBD take into account states' national sovereignty over genetic resources. Countries can provide access to their genetic resources, subject to mutually agreed terms and prior informed consent. Even though they are obliged to conserve biodiversity and promote sustainable use of natural resources in their territory, and in spite of the scope for more liberal approaches, many countries have created complex mechanisms for breeders to access such resources for plant breeding.¹⁴⁷ Such biodiversity policies thus impact the seed chain, particularly in the components dealing with breeding research and actual plant breeding. A more recent development seeks to facilitate access (and the sharing of benefits) through a so-called multilateral system. The 'International Treaty on Plant Genetic Resources for Food and Agriculture' (IT PGRFA – 2001) is likely to reduce the negative impact on seed systems of the implementation of the CBD through restrictive access regimes for a number of important food and fodder crop species, but not for many horticultural and minor cereals, legumes, and root crops.¹⁴⁹

Alternative national policies

An important step for the development of policies that better meet farmers' realities is that policy makers accept and recognize that farmers' or informal seed systems are by far the most important suppliers of seed. When reflecting upon existing policy frameworks, it is also critical that policy makers realize that both farmers' knowledge and their varieties are valuable. International and national attention to biodiversity and genetic resources creates such awareness among policy makers, but it only rarely (or slowly) trickles down to those policy levels that deal with seed regulations.

To do justice to these insights we need to develop policies for 'diversified seed systems',¹⁴⁵ i.e. taking into account the policy needs of both the farmers' or informal, and the formal seed systems and of the kinds of initiative for integrating scientific (formal) and farmers' knowledge and materials that are described in earlier chapters of this book. These policies should address two important issues: (i) ensuring that national laws based on policies directed at the formal sector do not impinge on the operation of the farmers' systems; and (ii) positively supporting the farmers' system and the integration approaches described in this book, such as participatory plant breeding, promoting adaptive seed technology, and small seed business development.

Avoiding negative impacts often requires minor changes to the national seed laws to redefine the words 'seed' and 'market', and to preclude over-regulation of

variety release and seed certification. It also requires minor changes to intellectual property rights laws, and more specifically to the definition of the farmers' privileges. Examples are available in northern seed laws, notably the concept in the USA of minimizing formal seed controls through 'trueness to labelling' instead of a formal certification system. This approach has limitations, however, when dealing with large numbers of illiterate farmers. The EU, which has a very strict seed regulatory framework (on which most of the developing countries' own laws are based) has recently been creating some interesting 'openings' in the seed laws. These openings cater, for example, for seed production of local varieties (called 'conservation varieties' in the EU). Another example is an opening in the patent law that creates a 'farmers' privilege' and in some EU countries a 'breeder's exemption'.

A more positive stance towards diversified seed systems may include a much more diverse set of policies, and not only those that are translated into regulations. One example is to support the development of community-based or small-scale seed enterprises which may require a gradual phasing in of seed quality controls and a supportive rather than a policing role for the seed certification officials. Support to participatory plant breeding commonly requires explicit investment strategies for public research and for civil society groups. It also involves changes in the reward systems for the public plant breeders since their involvement in participatory plant breeding may not lead to officially released varieties. This change may also require support for formally registering new farmers' varieties that may have value for farmers outside the participating communities. Another example is decentralization of seed production: support may focus on the multiplication of locally adapted varieties requiring positive investments in variety testing systems that identify such a broader range of varieties. Supporting farmers in reducing bottlenecks in their seed production practice may include the development of appropriate technologies and clear extension messages on diverse technologies related to such issues as seed-transmitted diseases, seed storage methods, and maintenance selection in varieties.* And finally, positive action may be needed to empower farmers to optimally develop their seed systems, e.g. through village seed banks, community genebanks, seed fairs and the organization of farmer field schools to share, extend and further develop farmers' experiences.†

Both in terms of 'opening up' regulatory frameworks and of positive actions, policy makers must take care not to compromise the legitimate interests of the formal system in those areas where they have some comparative advantages. Creating a too liberal approach may scare away investors in those commercial seed crops that the formal system could contribute to. In the field of IPRs, the World Bank therefore suggests different levels of protection of plant breeders' rights for commercial crops (export and national sectors) and crops that are mainly consumed in the home or are important for national food security and are produced through the informal seed system.¹⁵⁰

* Conny Almekinders and Niels P. Louwaars describe farmers' maintenance and selection of varieties more in detail in Section 2.1.

† Bhuwon Sthapit and colleagues describe various practices supporting community biodiversity management in Section 3.7

Beyond national seed policies

National seed policies are required to explicitly accept the diversity of seed sources that farmers draw on, and incorporate these into investment decisions and regulatory processes. Policy processes can, however, be quite slow in incorporating radical and unconventional ideas. Important steps can therefore also be taken by public organizations themselves, with or without the explicit blessing of their parent ministries.

The introduction of participatory approaches in plant breeding is an interesting example. Scientists have ventured into novel forms of cooperation with farmer groups without the consent of their national variety release committee, which initially opposed the ‘release’ of prospective new varieties for testing in farmers’ fields. The formal system may have problems accommodating truly participatory breeding, with new farmers’ varieties¹⁵¹ or varieties resulting from farmer-led participatory plant breeding;* these breeding approaches may not always lead to the uniformity required by the formal system. It is the institutional policies of the public research institutes that open up opportunities that go beyond the conventional seed chain approach.

Seed certification agencies also have a lot to offer in opening up the system with a more informal or experimental approach. In most countries, they are the best-equipped organizations with regard to seed quality. These organizations often focus exclusively on checking the formal seed systems and controlling the quality by taking sub-standard seed off the market. However, some of them have reinterpreted their mandate as not just to keep poor seed out of the market, but to help sustain the quality of the seed used by farmers. For example, the seed certification agency of Zambia actively offers its knowledge and expertise to civil society groups that help farmers to produce better seed (unsupported by the national seed law). Similar organizations in Sri Lanka, Thailand and other countries support seed villages that re-use certified seed in maintaining acceptable quality levels.

Finally, genebanks, which originally focused on the conservation, characterization and storage of genetic resources, and distribute them to ‘bona fide’ users in their formal mandate, have also been expanding their mandate in actively participating in the reintroduction of local varieties after disasters (e.g. Rwanda). Some are supporting farmers’ seed systems using a diverse set of varieties even where the national seed law prohibits the distribution of non-tested seed of unreleased varieties.†

All these examples show public institutions that are ahead in their views (and actions) with regard to diverse seed systems. Some of these actions are not strictly legal, and they may create risks for their managers. In most cases these actions are followed by changes in the formal policy and in adaptations of the rules or their interpretation where necessary.

* Farmer-led participatory plant breeding is explained and examples are given by Hans Smolders, Arma Bertuso and Bert Visser in Section 4.6.

† In Ethiopia, the Biodiversity Conservation Institute is involved in such activities as reported by Girma Balcha and Tesema Tanto in Section 3.4.

Towards conducive seed policies

Seed policies are there to guide the development of seed systems. When translated into investment decisions and regulatory frameworks, they can create conducive environments for securing the availability of good seed to farmers. However, the linear paradigm for the development of seed systems expresses the basic assumptions behind conventional seed policies, which are not in line with the farmers' reality. This has been identified by the African Union in 2008 as a major limitation in its call for integrated approaches to seed system development. The much more complex reality and the wide range of opportunities it offers require policy makers to undertake a wide range of actions to 'open up' the existing regulatory framework and to stimulate positive actions by organizations within the formal system to support farmers', or informal, seed systems.

7.2 Seed policies and regulations and informal seed supply in Ethiopia

Belay Simane

Introduction

This section outlines current Ethiopian seed policies and regulations and their influence on the informal seed supply system, and suggests opportunities for change. The section addresses the state of the art of federal and regional regulations relating to seed supply and bottlenecks within the current policy and regulatory framework for supporting farmer-based seed production and marketing. It identifies opportunities for policy development and readjustment, and for decentralization of seed sector activities, i.e. moving responsibilities from the federal to the regional governments.

The formal seed system: an historical overview and structure

Improved seed production and distribution in Ethiopia began in the 1940s with the establishment of the agricultural colleges. Until the late 1970s, the Ethiopian seed programme was very ad hoc and seed multiplication was uncoordinated. In 1976, the National Crop Improvement Committee (NCIC) set up the National Seed Council (NSC) to formulate recommendations for seed production and the supply of varieties released from the national research programs. In 1979, the Ethiopian Seed Corporation (later renamed the Ethiopian Seed Enterprise, ESE) was established to institutionalize seed production, processing, distribution and quality control of improved varieties. The NCIC initially handled variety release. In 1982 the National Variety Release Committee (NVRC) took over this task; the NVRC expanded its activities to evaluation of verification plots, and registration of varieties. In 1966, with some assistance from UNDP and FAO, the government established the IAR (now Ethiopian Institute of Agricultural Research, EIAR). During the last ten years, with some federal government and foreign assistance, the regional governments established the Regional Agricultural Research Institutes (RARIs). The regulatory institution, the

National Seed Industry Agency was established by the government in 1993, and strengthened through funds obtained from IDA and IFAD under the Seed System Development Project (1996-2001). As a successor to the NSIA, the National Agricultural Input Authority (NAIA) was established in 2003 by merging the NSIA and the National Fertilizer Industry Agency (NFIA). During the restructuring of 2004, federal institutions conducting activities directly related to the agricultural sector were brought under the Ministry of Agriculture and Rural Development (MoARD). Accordingly, the Agricultural Input Quality Control and Inspection Department and the Agricultural Input Market Department are institutionalized under the MoARD. However as mentioned in Section 1.1,* MoARD is being reorganized where the main responsibilities and activities will be retained, but will be realigned within new coordination offices or organizational units of the Ministry. The ESE is the major player in seed production in the formal system. ESE coordinates the Farmer-Based Seed Production and Marketing Scheme (FBSPMS);† there is some ambiguity as to whether this scheme should be considered as formal or informal seed production.

Seed policy and regulatory environment and bottlenecks for the informal system

In November 2001, the Ethiopian government issued Rural Development Policies and Strategies, i.e. the apex policy for the economic and social development sectors. All other policies, including those issued before this date have to be put in line with this policy. The seed system is guided by the National Seed Industry Policy (NSIP) and regulated by Plant Protection Decree No. 56/1971, Plant Quarantine Regulation No. 4/1992, Seed Proclamation No. 206/2000 and guidelines based on this proclamation, and Plant Breeders' Rights Proclamation No. 481/2006. Seed standards, field and laboratory manuals, and variety evaluation and release guidelines are also vital tools for the regulation of the seed industry.

The National Seed Industry Policy and Strategy

The National Seed Industry Policy and Strategy was formulated in 1992 with the aim of facilitating and regulating the production and marketing of quality seeds. Under Article 7, the policy promotes the active participation of farmers in the seed industry and the sustainable use of local cultivars. The seed proclamations, guidelines and seed standards issued are in line with the NSIP and Strategy and should support the development of a sustainable seed system.

Seed Proclamation No. 206/2000

Seed Proclamation No. 206/2000 defines the institutional framework with the basic tasks and responsibilities of authorities for seed industry development. The major issues addressed in the proclamation are: (i) streamlining the evaluation, release,

* In Section 1.1 Zewdie Bishaw, Yonas Sahlu and Belay Simane describe the status of the Ethiopian seed sector.

† In Section 1.2 Yonas Sahlu, Belay Simane and Zewdie Bishaw describe the farmer-based seed production and marketing scheme.

registration and maintenance of varieties developed by national research systems; (ii) developing effective seed production and supply systems through the participation of the public and private sectors; (iii) creating functional and institutional linkages among key players in the seed industry; and (iv) regulating quality, import-export trade, quarantine and other seed-related issues.

The seed proclamation recognizes the participation of farmers in seed production as contract seed farmers to registered seed companies. However, there is no legal provision for farmer-based seed production within the informal system. Article 14 of the seed proclamation, on seed production, processing and marketing, states that “any seed produced and processed locally or imported, or to be exported or to be sold and distributed in the country shall be from a variety registered by the Agency and shall conform to the requirements and seed standards of Ethiopia”. This does not give legal status to farmers in producing and marketing their own seed.

Plant Breeders’ Rights Proclamation No. 481/2006

Plant breeders’ rights, promulgated under proclamation No 481/2006 were established in February 2006, but are not operational yet. These rights aim to provide recognition and economic rewards for those who contribute to the development of high quality improved varieties. Article 27 of the proclamation recognizes the rights of farmers to save, use, exchange and sell both farm-saved seed of local cultivars and protected varieties; this is not in line with the UPOV guidelines. The proclamation explains the following issues in detail: (i) scope, exemption, restrictions, and duration of plant breeders’ rights, and persons entitled to them; (ii) transfer and provocation of plant breeders’ rights; (iii) infringement of plant breeders’ rights; and (iv) farmers’ rights to use both local cultivars and protected varieties.

Standards and guidelines

The available seed standards, field and laboratory manuals, and variety evaluation and release guidelines are vital for the regulation of the seed industry. However, these regulatory tools do not have any special provision for addressing the informal seed system. There are 74 seed standards that are currently in use. Compared to those of neighbouring countries, these standards are too high even for the formal sector, let alone for the informal sector. There is no provision for the release of varieties resulting from participatory plant breeding. Variety release and evaluation mechanisms are not very strict. The standing National Variety release Committee (NVRC) and various ad-hoc technical committees drawn from different institutions, have enormous problems in the coordination and implementation of the planned activities.

Opportunities for policy improvement

The long-term vision for Ethiopia is to ensure farmers easy and cost-effective access to improved seed, through well-functioning seed systems. Through policy assessment and dialogue, the following issues should be addressed to reinforce farmer-based seed multiplication and marketing in Ethiopia.

- Some of the sections and articles in the NSIP need to be revisited to encourage small-scale farmers' and cooperatives' involvement in seed production and marketing. The seed policy needs to accept farmer-based seed production and marketing as an integral part of the wider seed system for ensuring seed availability and seed choice to farmers.
- A new law or an amendment to the existing Seed Proclamation No. 206/2000 has to be formulated to address the institutional framework with the basic tasks, responsibilities and responsible authorities for the development of the informal system.
- The seed standards that are currently in use are too high even for the formal sector; it is therefore necessary to set achievable and fair seed standards for the farmer-based seed multiplication system.
- For farmer-based seed production, a system for 'quality declared seed' should be established; such a system will help farmers to obtain quality seed on time and at cost-effective prices.

Opportunities for decentralization

Considering the current Ethiopian political and the agro-ecological situation, there are quite firm grounds for decentralizing seed production and marketing activities.

Political grounds

The Ethiopian constitution is built upon the decentralization of administration. Decentralization, first to the regional, and now to the *woreda* and *kebele* levels, is a centrepiece of Ethiopia's strategy for ending poverty, both to improve responsiveness and flexibility in services delivery, and to increase local participation and the democratization of decision-making. The objective of decentralization is to transform Ethiopia from a highly centralized unitary state into a federal government based on substantial devolution to the lowest level of planning unit. This provides a foundation on which to build the decentralization of the seed system.

Agro-ecological grounds

Ethiopia is a country of great geographical diversity with altitudes ranging from 110 meters below sea level to 4620 meters above sea level. There are 18 major agricultural zones and 62 sub-zones with their own physical and biological potentials and constraints. Crop requirements are specific in terms of soil types, amount of moisture, temperature and other climatic factors. Hence, crops perform well when their specific requirements are met. The requirements for seed production are even more precise than those for grain production. Hence, seed production of crops should be targeted at the agro-ecology where the best performance in terms of yield and quality can be expected. In view of this, and the limited agro-ecological coverage of the ESE farms, there are good grounds for the decentralization of seed production.

Administrative grounds

The ESE is involved in both formal sector seed supply and the farmer-based seed production and marketing scheme, with competing interests, particularly as a profit

making public seed enterprise. The latter involves a large number of farmers, with a huge task in administration and coordination. In view of the regions' good experience of handling and administering the farmer-based seed production and marketing scheme, there is scope for decentralizing the scheme.

Policy grounds

Article 22 and 30 of the national seed law requires the establishment of seed testing centres and appointment of seed analysts. Seed analysts should be appointed in a decentralized regulatory regime to perform seed testing in accordance with the prescribed terms and conditions.

Conclusions

In Ethiopia 80 to 90% of the national seed requirement is covered by the informal seed sector. The current seed policies, laws, regulations and institutional framework need to be revisited and modified so that they support and encourage the development of the informal seed system and designate the basic tasks, responsibilities and responsible authorities involved.

Considering the existing political, agro-ecological, institutional and policy frameworks of the country, there are strong grounds for decentralizing the current farmer-based seed production and marketing activities as coordinated by the ESE, and establishing a sustainable seed system in the country. Quality control should be enforced for 'quality declared seed' with proper labelling and pricing. The regulatory capacity of public sector agencies should be strengthened to enforce quality control standards at the point of sale. Infrastructure development and training farmers to produce and sell their seeds effectively should be the bottom line of the informal seed system.

7.3 International dimensions of plant variety protection and informal seed supply in Ethiopia*

Robert J. Lewis-Lettington

Why an interest in plant variety protection in Africa?

African interest in the implementation of plant variety protection (PVP) regimes is negligible, with only one or two exceptions, namely South Africa (UPOV member since 1977) and, to a lesser extent, Kenya (statute entered into force in 1972 but necessary implementing regulations not completed until 1994). PVP is a relatively recent phenomenon in Africa and seems to be driven by two principal factors. The first factor is legal and relates to the obligation to implement some form of PVP

* The views and opinions expressed are those of the author and do not reflect the official positions of Bioversity International in any way. The author also accepts responsibility, and apologizes, for any errors of fact.

regime that almost all African states have accepted under paragraph 27.3(b) of the World Trade Organization-related Agreement on Trade Related Aspects of Intellectual Property Rights (TRIPs). The second factor is primarily practical and is that some form of PVP is often seen as a prerequisite for an export-oriented horticulture sector, particularly where ornamentals are concerned but also, to a slightly lesser degree, for vegetables. In most instances, the factor of export orientation is driven by, or at least geared to, the European Union; which happened to be where the dominant international iteration of PVP, the International Convention for the Protection of New Varieties of Plants (UPOV Convention), was developed.

Although legal obligations and the desire to support horticulture are the principal motives for adopting PVP in Africa, a third factor appears to be exerting an increasing influence over policy discourses. This is the way in which public sector research institutions are beginning to perceive PVP as a means to offset declining research budgets and as a mechanism to engage with the private sector. This objective has developed as liberalization and privatization policies have begun to diversify the seed distribution sector in many countries during the 1990s and 2000s. It is based on the private sector tendency to prefer the exclusive rights that intellectual property rights, such as PVP, can provide, even in the presence of the near monopolies already available through most seed laws. These institutional objectives of public sector research are frequently actively supported by the individuals that it employs, as breeders see PVP as a means of enhancing their personal incomes. The Kenya Agricultural Research Institute (KARI) provides perhaps the clearest case of all of these factors to date. Its active adoption of PVP was, at least partially, pursued on the basis of a consultant's recommendation that it could provide up to 8% of operating costs and has been rapidly followed by demands by researchers for a direct share in any royalty income.¹⁵²

Legal obligations for PVP under TRIPs paragraph 27.3(b)

The legal obligations to implement plant variety protection that countries have assumed under TRIPs are sometimes misunderstood and it is useful to review what is actually required, to ensure that the available flexibilities are fully understood. The first basic requirement is that countries must provide for the protection of plant varieties. Without going into too much detail, it is important to note that neither the concept of protection nor the nature of a plant variety are defined or clarified in any way under TRIPs. Protection is a very subjective concept, according to one's interests and objectives, while the exact definition of a plant variety can be manipulated to serve innovation-related or other socio-economic goals. The mechanism for protection to be used is left even more open, with the options of using patents, effective *sui generis* systems, or combinations of the two all being acceptable. Considering that *sui generis* simply means 'of its own kind', the reference to a combined approach would seem somewhat redundant, as a *sui generis* system in this context could reasonably be argued to be just about anything that wasn't a pure patent system. The additional requirement that a *sui generis* system be 'effective' does not restrict options much, if it all, because 'effective' is no less subjective a concept than 'protection'.

In general terms, all of the key elements of paragraph 27.3(b) are left undefined by the TRIPs Agreement and remain to be interpreted at the national level. This provides enormous scope for countries to develop PVP systems that comply with TRIPs but that are also tailored to their particular circumstances and objectives. PVP may well link with global trade patterns, particularly in the horticultural sector. However, this situation does not alter the fact that countries are very diverse in their socio-economic and technological conditions and, therefore, will presumably need variations on the basic mechanism of PVP to achieve optimum implementation.

Perceived practical benefits of PVP

As in the case of the nature of legal obligations to implement PVP, there is often some confusion as to the practical benefits that the implementation of a PVP regime may provide. This is particularly so because of the fact that almost no developing countries have enough experience of implementing PVP regimes to accurately assess their impacts and because there have been some relatively heated debates regarding cause and effect relationships where impacts have been observed. However, several core potential benefits have been posited as those that PVP regimes will promote and, regardless of the state of debate and individual positions, it is reasonable to put these forward as measures by which the implementation of a PVP regime may be assessed.

First, PVP regimes are believed to increase the range of varieties to which farmers have access. This effect is based on two related influences. One is that the existence of a PVP regime provides greater incentives for investment in plant breeding and the other is that the regime provides greater security for those who have developed varieties, whether locally or imported. A second core potential benefit relates to the fact that the key horticultural markets, particularly the European Union markets to which Africa is so closely linked, all have their own PVP regimes based on the UPOV Convention. While these regimes allow them to control the import of protected varieties, even where these originate in countries without PVP, compatibility between producer and market regimes may enhance export options by increasing confidence and generally lowering transaction costs. The third, and final, core potential benefit to be discussed here is that a PVP regime should promote the privatization of research at a time when Africa's traditional public sector research institutions are under constant financial pressure. This restructuring of national research sectors should lessen the burden on government budgets and may, as some argue, lead to greater efficiency and diversity in research.

Ethiopian Plant Breeders' Right Proclamation No. 481/2006

Ethiopia's implementation of a PVP regime is provided for in the Plant Breeders' Right Proclamation, No. 481/2006. While Ethiopia is not currently a member of the World Trade Organization, it has applied and is, therefore, seeking to bring its legal system into compliance with the Organization's requirements, including those of TRIPs. Ethiopia also aims to expand its horticultural trade with the European Union and is seeking to promote plant breeding and the seed industry internally. This latter point is clearly highlighted in the Preamble to the Proclamation. The aim here is not to provide a comprehensive analysis of Proclamation No. 481/2006 but, rather, to

highlight the relationship between it and efforts to promote the informal seed supply system in Ethiopia.

Proclamation No. 481/2006 is, in many respects, a relatively orthodox interpretation of PVP that follows the basic structure and detail of the UPOV Convention. Recognizing that the UPOV Convention is primarily focused on the development of new varieties within the context of formal, relatively capital intensive, breeding programmes, the Proclamation seeks to introduce balancing elements focused on promoting the less capital-intensive activities of farming and pastoral communities, as highlighted in the Preamble to the Proclamation. These elements are primarily provided for in Sections 6 and 28. Section 6 provides for broad exemptions for the traditional activities of communities, particularly use and exchange, and the main limitations on these are that 'commerce' and 'commercial scale' remain prohibited. However, there are no definitions of 'commerce' and 'commercial scale' and, therefore, until these might be clarified in regulations, some ambiguity remains. Section 28 is similar to Section 6, in that it also provides for farmer-oriented exemptions from compliance with plant breeders' rights. However, it differs in that it focuses on more individually oriented exemptions and, in effect, creates a situation where almost the only prohibited activity for an individual farmer is misrepresentation of their seed as a protected variety.

The fundamental point to note in the context of sections 6 and 28 is that they imply a view of the seed system that emphasizes a perceived dichotomy between two discrete sectors: the 'informal' and 'formal'. However, this tends to exclude the possibility of viewing the seed system as a continuum and, as such, to allow for activities that may exist between the two poles.

Ethiopian Proclamation No. 481/2006 and the semi-formal seed industry

Although the exact situation might vary slightly according to the nature of proposed activities, it is unlikely that Proclamation 481/2006 creates sufficient exemptions from the plant variety protection framework to accommodate a semi-formal seed industry. Even a relatively modest semi-formal seed industry has, by its nature, some form of commercial aspect and thus cannot be exempted under Section 6. It might be possible to establish some form of cooperative under Section 28, but this is also unlikely on the basis that it is hard to argue that it falls within reasonable understandings of traditional activities.

However, there is a question as to whether one would really care whether a semi-formal seed industry would fall within the exemptions of sections 6 and 28 or not? These are only relevant in situations where that semi-formal industry would seek to make use of, or depend on, varieties protected under the Proclamation. For all farmers' varieties and other unprotected varieties, the question of plant variety protection, and exemptions from it, is essentially irrelevant and provides no barrier to activities, commercial or otherwise. The limitations of plant variety protection, and scope of exemptions from it, are only of concern if you want to access and make use of protected varieties. However, it is also possible that a semi-formal seed industry might develop varieties that it wishes to protect. In this instance, it is important to consider two factors, one specific and one more general. At a specific level, it is

essential to determine whether the varieties that might be protected provide enough added value, and are thereby likely to generate enough demand to be able to justify a high enough seed/grain price ratio to cover necessary costs and generate minimum profit levels. If the additional costs accrued and time lost in the process of protection are likely to outweigh any benefits, or limit demand in a target market, then protection might be counter-productive. At a more general level, one must consider the objectives and purpose of promoting a semi-formal seed industry. If the aim involves smallholders as a target market for expanded access to seed, whether also as variety providers or not, one must consider that this market is extremely price sensitive. Establishing a semi-formal seed industry based on monopolistic protection mechanisms might lead to its imitating the existing large-scale commercial seed sector and failing in its seed access expansion mandate.

Key concerns

While earlier discussion has raised a number of possible positives and negatives in the relationship between plant variety protection and the promotion of a semi-formal seed industry in Ethiopia, the next two sections highlight a series of further issues that one should consider in the development of a semi-formal seed industry within the framework of existing plant variety protection law. Three main concerns are commonly cited. First, the likelihood that the use of plant variety protection within a seed system will tend to promote genetic uniformity, primarily due to the 'distinct, uniform and stable' criteria of plant variety protection mechanisms, including Ethiopia's. While there is some debate about this issue, at a minimum, it does seem to be a genuine concern in the commercial farming sector and, as such, raises a number of questions that the promoters of a semi-formal seed industry should address.

A second commonly cited concern is that plant variety protection, in common with other intellectual property rights, is based on a monopoly mechanism. Monopoly mechanisms function because of their ability to exclude; i.e. the value of information is increased by the ability to exclude people from using it. In a resource-poor setting, it can be argued that this, in effect, operates as a tax with disproportionate impact on the poor because of the ability of wealthier farmers to offset, and indeed profit from, these costs through additional investments in inputs and access to better quality land.

The final commonly cited concern about plant variety protection to be discussed here is its relationship to investment in plant breeding and the seed industry generally. As discussed above, this is one of the main incentives for implementing plant variety protection regimes. However, the relevant authorities need to monitor any investment patterns associated with plant variety protection quite closely. On the one hand, plant variety protection can provide a mechanism for transfer pricing, where international companies limit tax liabilities (and thus benefits to developing economies) by manipulating the transactions between parent and subsidiary companies. On the other hand, anecdotal evidence from several countries suggests that competition around plant variety protection rights is relatively low and, therefore, there is a risk of very high royalty rights that limit the options for expansion among developing country actors and generally create high barriers to entry in fields such as horticulture. Of course, it should be noted that these financial concerns are not unique

to the context of plant variety protection and may be found in most trans-national investment scenarios.

Key positives

The most frequently cited positives from the introduction of plant variety protection into a seed system are, in some respects, mirrors of concerns and, as such, highlight the ongoing debate and the limits to conclusive empirical evidence around such legal regimes. First, despite concerns that plant variety protection promotes genetic uniformity, it is also often argued that it can serve to actually promote diversity. This is primarily the result of the regime acting as an incentive for the commercialization of new varieties that might not otherwise have been developed. As with so many things, it is possible that both points of view might be correct. This is possible because the answer may well depend upon the initial context: plant variety protection might well increase diversity in relatively uniform contexts and yet decrease it in relatively diverse ones. However, this is mere speculation and there is a clear need for longer term empirical research.

The second key positive aspect of plant variety protection is that it provides a mechanism for farmers to improve their incomes, as the overall gains from protected varieties will outweigh the additional costs associated with that protection. This becomes particularly significant where government research budgets are low and sometimes poorly directed, because it creates a mechanism whereby the private sector can fill the gap. The effectiveness of this impact is likely to be dependant upon a series of variables but, at a minimum, seems probable in market-oriented sectors.

The final two positives to be discussed here are actually more means by which plant variety protection regimes limit or prevent some of the negative impacts that they are often thought to cause. The first of these is that plant variety protection regimes are unlikely to create a significant barrier to participatory plant breeding and other forms of farmer-based or smallholder-oriented seed development. There are two reasons for this: one is that these activities rarely, if ever, make use of protected varieties; the second is that plant variety protection laws usually provide for broad exemptions for breeding using protected varieties. This is certainly the case with Ethiopian Proclamation 481/2006 but, in other countries, one must be careful that the concept of essentially derived varieties, introduced into the 1991 text of the UPOV Convention, is not manipulated or abused in a manner that negates this feature of plant variety protection.

Finally, there is the question of the relationship between plant variety protection and farmers' rights to save and re-use seed. There may be problems where farmers are only planting protected varieties in one season and then seeking to save and re-use seed in the following season. However, among smallholder farming communities where the saving of seed is a major feature of the seed system, farmers tend, if they use protected varieties at all, to blend these with other seed, so that any seed saved is not purely of a protected variety. The abuse of the concept of essentially derived varieties is again a major concern here but, with that caveat, it is hard to see how plant variety protection might directly impact farmer seed saving practices.

Seed laws and the semi-formal seed industry

While most of this section has considered the relationship between plant variety protection regimes and the promotion of a semi-formal seed industry, it is also important to consider the role of a third element: seed laws. At the time of writing, there is, throughout Africa, significant pressure and momentum towards sub-regional and regional harmonization of seed laws. This is largely based on a typical globalization argument, where harmonized rules will facilitate cross-border trade in seed, allowing for greater economies of scale and wider access to technology. It does seem highly likely that harmonization will promote the activities of large seed companies and benefit high input farming, where the local specificity of seed is less important than in the smallholder sector. However, the current harmonization efforts are based on the wider replication and linking of seed laws following a relatively rigid structure that focuses on the commercial agriculture sector, in the same way that plant variety protection regimes tend to do. The fact that many seed laws also contain a distinct, uniform and stable monopoly mechanism at their heart is a vivid illustration of this link.

Seed laws and rules are mechanisms that are intended to improve efficiency by collectively confirming information that farmers need to be able to verify to be confident in their seed choices. Instead of each farmer seeking to individually confirm information provided by each seed supplier, a central authority confirms the seed supplier's information once and for all through seed certification. However, this mechanism is dependent upon the ability of the central authority to accurately assess the nature of information that a farmer will seek to confirm. Seed laws generally target information, and impose financial and time transaction costs that are relevant to high input agriculture: the sector that is best able to bear the costs of the mechanism and benefit from it. The degree to which this mechanism might also benefit seed production and distribution that targets local markets is unclear. Given such a lack of empirical evidence regarding the likely impacts of seed law harmonization on the actual seed sectors existing in most African countries, further research would appear necessary. This is particularly true when one considers that harmonized laws and rules have a tendency to become monolithic in the sense that they adopt a one size fits all approach and are relatively difficult to adjust once established. At a minimum, any harmonized system must include consideration of options for flexibility at the national and local levels and, preferably, should be based on an overall review of seed systems that envisions them as a spectrum running from the informal to the formal. This will allow for specific mechanisms designed to address the needs of semi-formal and farmer-based seed initiatives to be established alongside those designed for the commercial sector. The Ethiopian Proclamation 481/2006 on Plant Breeders' Rights begins to approach this path by its recognition of a diverse seed system and, hopefully, in its regulatory structures, it will go further to recognize the full diversity of this system and include consideration of initiatives such as the promotion of a semi-formal seed industry. In turn, these national experiences from Ethiopia should, as they are developed, be fed into the sub-regional and regional processes to ensure an appropriate balance between the interests of the commercial agricultural sector and the other diverse elements of the seed system that exist alongside it.

7.4 Biodiversity and genetic resource access laws and informal seed supply with specific reference to Ethiopia^{*}

Robert J. Lewis-Lettington

Basic legal framework

The international legal framework for access to genetic resources currently consists of two closely related instruments: the Convention on Biological Diversity (CBD, 1992) and the International Treaty on Plant Genetic Resources for Food and Agriculture (IT, 2001). The possibility of a third instrument, an agreement on farm animal genetic resources, is being widely mooted and a potentially more detailed interpretation of the CBD's access provisions is under consideration in the context of discussions for an international regime for access and benefit sharing. As the dates and names might suggest, the CBD provides the foundational provisions of contemporary understandings of access and benefit sharing, while the IT provides a sector-specific interpretation of these foundational provisions for crop-based agriculture.

Two key pillars of the CBD are the sustainable use of biodiversity, including genetic resources, and the fair and equitable sharing of benefits from that use. The underlying assumption in this approach is that a realization of the commercial value of genetic resources will increase awareness of the potential value of conserving biodiversity. In short, a market-oriented approach to promoting conservation. The basic link between the CBD and the IT was established at the point when the CBD text was adopted, with the Nairobi Declaration recognizing that issues of *ex situ* collections and farmers' rights were not addressed by the Convention, thereby laying the foundations for the IT negotiations. The underlying assumption of the IT expands slightly upon these issues by recognizing that the traditional agricultural research sector has special needs in the context of access and benefit sharing. These needs are largely based on the fact that the use of genetic resources in agricultural research tends to be characterized by, and benefit from, high volume and low margin transactions. This is in direct contrast to the low volume and high margin transactions that are the flagship successes of access and benefit sharing in the chemical and pharmaceutical sectors. There has been significant discourse to the effect that modern biotechnologies, particularly genetic modification, have more in common with the dynamics of the chemical and pharmaceutical sectors than with traditional agricultural research but the IT makes no direct distinction in this regard.

The Ethiopian Access to Genetic Resources and Community Knowledge and Community Rights Proclamation (No.482/2006) is primarily designed to implement the CBD framework in an orthodox manner that follows a commonly used approach targeting the chemical and pharmaceutical sectors. However, it also contains an

^{*}The views and opinions expressed are those of the author and do not reflect the official positions of Bioversity International in any way. The author also accepts responsibility, and apologizes, for any errors of fact.

explicit reference to the IT that provides for the optional implementation of its approach as a parallel mechanism operating through regulations (section 15.2).

How the international agreements link

Article 15 of the CBD establishes a basic framework of principles for access and benefit sharing but, partially based on the exclusions recognized by the Nairobi Declaration, the United Nations Food and Agriculture Organization's Commission on Genetic Resources for Food and Agriculture rapidly convened negotiations to revise the International Undertaking on Plant Genetic Resources, an earlier non-binding cooperative framework for agricultural research. The CBD's commitment to the establishment of a specific mechanism for access and benefit sharing in agricultural research was reiterated by a decision of the Conference of the Parties in 2000, which stresses that it is important that, in developing national legislation on access, parties take into account and allow for the development of a multilateral system to facilitate access and benefit-sharing in the context of the International Undertaking on Plant Genetic Resources, which is currently being revised (Decision V/26/A/7). In November 2001, the text of the IT was adopted as a replacement for the International Undertaking that provides a specific, but fully compatible, interpretation of the CBD framework that addresses both the Nairobi Declaration and Decision V/26.

What is a genetic resource?

In any legal instrument, the question of scope of application is of fundamental importance because it provides the basic outline of what is subject to the instrument's provisions and what is not. For the purposes of this section, the question is whether seed and propagating material, the raw materials of both formal and informal seed supply systems, fall within the scope of access to genetic resources regulations. All three of the instruments considered here use definitions as the key element in providing for their scope of application. In particular, the question of what falls within the understanding of 'genetic resource', which is the object of regulation in all of the instruments, must be considered.

Under the CBD, linked definitions of genetic material and genetic resource are used, producing a composite definition of 'any material of plant, animal, microbial or other origin containing functional units of heredity and of actual or potential value'. This clearly includes all forms of seed or propagating material, which fulfil both of the two main criteria of containing functional units of heredity and actual or potential value for humanity. The reason that the CBD definition is made up of the two nested elements, rather than some version of the composite used here, is largely a question of political history and emphasis. The term originated in the 1960s as a means of emphasizing the potential value of the heritable traits of biological materials to economic development. The two elements of the nested approach seek to emphasize, first, the key characteristic of heritability and, second, the fact that this characteristic has economic value.

The IT follows a very similar pattern to the composite definition from the CBD: 'any material of plant origin, including reproductive and vegetative propagating material, containing functional units of heredity of actual or potential value for food

and agriculture'. However, the IT definition contains two important variations from the CBD approach. The first is the obvious restriction of the definition to material of plant origin, following the Treaty's narrower scope. The second is the limitation of the value element to value for food and agriculture, which creates a very significant limitation on the subject scope of the IT. However, for the purposes of the discussion here, the distinctions between the CBD and IT definitions are of limited relevance because both clearly, and in the case of the IT explicitly, include all forms of seed and propagating material.

The Ethiopian approach in Proclamation 482/2006 varies from the CBD and IT approaches in form if not in substance, with one important exception. The basic structure of the definition follows that of the CBD, consistent with the Proclamation's primary function of implementing CBD Article 15: 'any genetic material or biological resource containing genetic information having actual or potential value for humanity and including derivatives'. There are no restrictions regarding only material of plant origin or of values relating to food and agriculture, as found in the IT. However, it is clear that such restrictions could be imposed on a subset of materials pursuant to Section 15.2. The inclusion of a reference to biological resources would seem to run counter to the CBD approach but, given the subsequent qualifications relating to genetic information and value, is unlikely to be read as leading to any substantive variation. There is no direct reference to the heritability of traits but, given the evolution of technologies and some of the possible problems with the CBD language, the alternative reference to 'genetic information' is probably substantially equivalent and may even be more practical. Where there does appear to be a substantive variation from the CBD is with reference to the question of derivatives, where the CBD is silent and the Ethiopian Proclamation contains a very broad understanding: "product extracted or developed from biological resource this may include products such as plant varieties, oils, resins, gums, chemicals and proteins" (sic). This definition of derivative suggests that the Ethiopian Proclamation does not only include seeds and propagating material, as with the CBD, but also claims to establish 'reach through' regulation of the products of such seed and propagating material, whether in the form of multiplied seed, improved materials or of commodities. The way this provision is made seems to establish that any derivative of an originally regulated genetic resource would be individually subject to regulation.

Sovereignty

Sovereignty is a much misunderstood concept that lies at the heart of all state powers and that is recognized as providing the basis for all regulation of access to genetic resources. The reason for the common misunderstandings is that sovereignty is a complex concept with a very wide range of implications that touch upon all aspects of the governance of a state. A convenient definition for the purpose of discussion here is, 'the international independence of a state, combined with the right and power of regulating its internal affairs without foreign dictation'. The two most common misunderstandings regarding sovereignty in the context of access to genetic resources are that, first, it is seen as meaning state ownership of genetic resources and, second, it is seen as being conferred by the CBD. The first misunderstanding confuses one

possible function of sovereignty, the establishment of property rights, with sovereignty itself. A state decision to declare genetic resources *res nullius*, or as having no owner and thus freely available to all, would be just as much an exercise of sovereignty as the decision to declare them state property. Sovereignty is the power to decide which property rights should, or should not, exist and how they may be exercised, rather than the rights themselves. The second misunderstanding is a failure to recognize the source of sovereignty. Sovereignty is innate to a state and basically derives from its jurisdiction over territory and people, although different political systems tend to view the precise details in slightly different ways. An international agreement is, therefore, actually established through the exercise of sovereignty by states: it exists because states use their collective sovereignty to say that it does. As such, international agreements are actually seen by lawyers as restrictions on sovereignty rather than sources of it. Through an international agreement, two or more states agree to temporarily limit their exercise of sovereignty as described in the agreement. In this context it should be realized that sovereignty is innate and absolute and cannot, therefore, ever be permanently surrendered (e.g. in the way that property rights can) except by the dissolution of the state which has the right to exercise it and, even in this case, it may be argued that sovereignty is not surrendered but merely transferred to a new sovereign power. In the case of international agreements falling short of the dissolution of a state, this means that a state always has some form of right to withdraw from an agreement.

Article 15.1 of the CBD recognizes that states have sovereignty over their natural resources, including genetic resources, and, therefore, that they have the ultimate right to decide on questions of ownership and access. This means that, while the rest of Article 15 establishes a basic framework for access to genetic resources, the CBD accepts that states are exercising their sovereignty in doing this, and that they are free to interpret the details of this framework according to national law and practice. The IT goes significantly further than the CBD on the question of the exercise of sovereignty because, through the Treaty, states have agreed to make a selection of plant material available on fixed terms and conditions that constitute a detailed interpretation of the CBD framework. That is, they have limited their sovereign right to determine these terms and conditions unilaterally. The ongoing discussions for an international regime for access and benefit sharing under the CBD would, if successful in their current objectives, bring the level of limitation of sovereignty under the CBD to one similar to that established under the IT.

In Proclamation 482/2006, Ethiopia has clearly exercised sovereignty by establishing that the ownership of genetic resources lies with the state and that the ownership of community knowledge lies with those communities. The author assumes this approach is compatible with the constitution of Ethiopia (constitutions essentially being the rule book setting out how governments may exercise sovereignty on behalf of the state), as it is not the purpose here to consider such matters. Having established these basic points, the bulk of the Proclamation then goes on to address the manner in which the government, in this case on behalf of the state, and communities may exercise their rights of ownership. In effect, these detailed provisions constitute

limitations on the rights of ownership, as ownership may only be lawfully exercised in compliance with them.

Facilitated access

Article 15.2 of the CBD provides for the main limitation on sovereignty that parties to the Convention have agreed to: that they will facilitate access to genetic resources, provided that this access is for purposes that do not run contrary to the Convention's objectives. The basic requirement is that states should make access to genetic resources within their jurisdiction as easy as possible, within the limitations of the other provisions of Article 15 and the basic requirements of sovereignty. The qualification relating to the Convention's objectives may be assumed to mean that access should be subject to the overriding concerns of the conservation and sustainable use of biodiversity.

The IT matches the CBD's requirement for facilitated access by states agreeing to make a specific list of materials, as provided for in Annex I of the Treaty, available to all, subject only to a predetermined set of terms and conditions detailed in the Treaty and its subsidiary instrument, the Standard Material Transfer Agreement. As a result, both providers and recipients are made fully aware of their rights and responsibilities, even prior to the completion of any exchange, and transaction costs are reduced to a minimum. The major exception to this standardized, 'as of right', system is that it is limited to access to materials that are under state control and in the public domain, as this is all that states can basically agree to without contradicting earlier sovereign actions regarding the creation of private property rights. There is also a further limitation, which is that the uses of material accessed are restricted, largely to the field of food and agriculture, which matches the basic scope of the IT discussed above.

Ethiopian Proclamation 482/2006 does not specifically refer to facilitated access but may be deemed to be generally fulfilling this requirement by providing for a clear process by which genetic resources may be accessed. However, some key questions do remain, in particular the nature of the yet to be promulgated regulations on prior informed consent and the degree to which the authorities are bound to the criteria established for the acceptance or rejection of a request for access. This latter point may be important to applicants for access in terms of the transparency of the access process. The Proclamation also allows for the possibility of establishing a distinct facilitated access process for agricultural materials by allowing for a direct co-opting of the IT's provisions for that purpose, something that is dependent upon future regulatory action.

Country of origin

Article 15.3 of the CBD provides for the identification of countries of origin as a means of identifying the relevant rights holders in the case of particular genetic resources. Countries of origin are deemed to be those where particular material is found in *in situ* conditions or, in the case of cultivated species, where they developed their distinct characteristics. The distinction between cultivated and non-cultivated species is made as a means of dealing with the fact that cultivated species have been

moved around the world for centuries prior to the conception of the CBD, so that the relationship between their ultimate centres of origin and any contemporary sovereign rights is tenuous at best. Many commentators suggest that this may be equally true of non-cultivated species, given that the science of centres of origin is still often unreliable and open to debate. One category of providers of legitimate authorization for access to genetic resources is, therefore, countries of origin. A second category consists of those who have legitimately acquired material pursuant to the CBD, whose authorization is presumably subject to any restrictions under which they obtained access. In this regard, it is important to note that the failure of a country to establish an access to genetic resources regime does not necessarily mean that all access is illegitimate. It is more likely, in the absence of any specific provisions, to be deemed *legally* legitimate, although the political aspect of things may be more complex. A third category is *ex situ* collections developed prior to the entry into force of the CBD but provided for under the IT, which largely consist of those of international agricultural research centres.

The IT largely sidesteps the question of country of origin and focuses on the underlying question of the relevant rights holders who may authorize access. Using the IT's multilateral system, countries surrender not only their right to determine the individual terms and conditions of access but also their right to authorize it. As a result, it is the multilateral system that becomes the source of the legitimacy of access and the question of country of origin becomes a moot point, particularly as it is also the multilateral system that accrues benefits, as discussed below.

In Proclamation 482/2006, Ethiopia does not directly address the question of country of origin and adopts a *de facto* position that Ethiopia will act as the country of origin of all material found in Ethiopia, whether or not it is actually the country of origin. This is considered to be *de facto* on the basis that it is not explicitly addressed but, since the Proclamation establishes that Ethiopia will assume the rights and obligations of a country of origin, in particular the right to authorize access, for all material accessed within its jurisdiction, this is the ultimate practical effect. There are no CBD compatible references to the rights of countries of origin as defined in the CBD and there is no provision for rights acquired through legitimate acquisition. While the author is not familiar with the details of property law in Ethiopia, it is probable that rights established through legitimate acquisition will, however, be recognized, as, otherwise, the Proclamation would have the effect of extinguishing prior rights. While this anomaly might be addressed by clever drafting of regulations for implementation, for the moment it would appear that the Proclamation is, in this respect, not in compliance with the CBD in its failure to recognize the rights of countries of origin.

Mutually agreed terms

Sub-articles 15.4 and 15.5, along with 15.7, provide the central operative elements of the mechanism for access to genetic resources adopted by the CBD. While all of these three sub-articles have been the subject of much debate since the entry into force of the Convention, they are not particularly complex, or even original, in their basic form but are, rather, adopted directly from the almost universally accepted principles of

legal contracts. 15.4 states that access to genetic resources must be subject to mutually agreed terms. No detail is stipulated, only that such terms must exist. This reflects the traditional legal principle that a valid agreement cannot be based on fraud or duress.

The IT matches the CBD requirement for mutually agreed terms by actually stipulating what those terms are in the various relevant articles of the Treaty and its subsidiary instrument, the standard material transfer agreement. This reflects the mutual agreement between the states that negotiated the Treaty as to the terms upon which they will all provide access to, and receive, listed material. Any states acceding to the Treaty subsequent to the agreement on its text are deemed to mutually agree with the existing parties through the act of accession and any other collections, such as those of the international agricultural research centres, are similarly deemed to agree to the terms upon submitting their collections to the jurisdiction of the Treaty.

Proclamation 482/2006 lies somewhere in between the approaches of the CBD and of the IT. It does not provide the sort of precise terms and conditions found in the IT, but it does move beyond the basic principles found in the CBD by providing an indicative outline of typical terms. This, at least, provides a signal as to the intentions and objectives of the competent authority in any negotiations. This indicative outline appears to be flexible but, to a large degree, this is highly dependent upon administrative interpretation.

Prior informed consent

Sub-article 15.5 of the CBD is very closely related to 15.4 and requires that any access to genetic resources must be on the basis of prior informed consent. The basic meaning of this is straightforward: any transaction must be clearly understood and agreed to prior to its actually taking place. However, in practice things tend to be significantly more complex, particularly due to varied perceptions of the appropriate standards for 'informed' in the context of highly asymmetrical relationships between key actors and a general lack of clarity regarding who it is that must be informed and consent on the providing end of the transaction. Despite these problems, the CBD is actually very clear about who should give their consent: the state or whatever other actors the state may empower. This is a reflection of the sovereignty principle recognized by sub-article 15.1, as it is for the state to determine issues of ownership and rights.

The IT does not specifically address the question of prior informed consent because it considers that all states that are parties to the agreement, and the rights holders of any other collections submitted to it, have given their prior informed consent, if not during the Treaty negotiation process, then during the process of ratification, accession or submission. Given that the Treaty only applies to material under state control and in the public domain, private rights holders are not affected.

Proclamation 482/2006 establishes a basic approach to prior informed consent that broadly mirrors that of the CBD, albeit one that is more complex where community knowledge is deemed to be at issue. Where one is seeking access to genetic resources, without any community knowledge content, only the consent of the Institute of Biodiversity Conservation (IBC) is required, as the IBC acts as the competent authority on behalf of the state. Communities are given the right to

petition the IBC regarding any decision it makes but only post facto and it is not clear what obligations such a petition might impose upon the IBC. Communities have stronger rights of prior informed consent where community knowledge is concerned, but these rights are still shared with the IBC and are subject to the promulgation of regulations on the issue. In addition to rights of prior informed consent by communities, customary law is also deemed to apply to access to community knowledge. Given that customary law is rarely codified and raises political questions when being interpreted by state agencies, this is likely to be a complex and challenging issue in a country as ethnically diverse as Ethiopia.

Research

The CBD's specific reference to research based on genetic resources in sub-article 15.6 is, in many respects, an aspect of benefit sharing and can be considered as much a question of emphasis as of substance. The CBD includes two non-binding recommendations: that research involving genetic resources should involve the country providing access to those resources and should take place in the country of origin. This is clearly intended to contribute towards the technological development of countries of origin that are developing countries and avoid their playing a role purely as raw material providers.

The IT follows the same approach to research as the CBD, at least to the extent that it seeks to promote exchanges that will avoid developing countries acting purely as raw material providers. It does not link particular resources and associated research activities with particular countries but rather seeks to generally promote collaborative research projects and access to technology involving genetic resources accessed under the Treaty's multilateral system.

Proclamation 482/2006 almost exactly follows the provisions of the CBD regarding research. Sub-section 12.7 establishes a non-binding requirement that research involving genetic resources accessed from Ethiopia should take place in Ethiopia with the involvement of Ethiopians. The non-binding element is introduced by the fact that the requirement should be fulfilled unless "it is impossible". Presumably this does not actually mean 'impossible', a situation which might never exist, but rather is intended to mean impractical or undesirable.

In general terms, the CBD's research requirement, and the associated technology transfer provisions found in the CBD and other international agreements have proved controversial, with many commentators bemoaning their lack of effective implementation. However, in the case of the CBD, at least anecdotal evidence suggests relatively significant interest and activity in this area.

Benefit sharing

Sub-article 15.7 of the CBD contains the Convention's main provisions regarding benefit sharing, although there are numerous direct and implied references elsewhere in the text, and, as such, it represents one of the pillars of the agreement. However, apart from establishing the basic principle of benefit sharing, the CBD defers to national jurisdictions regarding all details. What the CBD does require, is that all parties must take measures "for fair and equitable sharing of research results and

benefits from use". This creates an obligation for states acting as both providers and recipients of genetic resources and does not discriminate between developed and developing countries. Particular emphasis is placed on three categories of benefit: technology transfer, biotechnology and monetary benefits (both bilateral and multilateral).

The IT, primarily in its Article 13, follows the basic pattern of benefits proposed by the CBD, albeit with more detail, particularly regarding monetary benefit sharing. However, the IT stresses that the ability to access material that it guarantees to all of its parties constitutes the primary benefit it will provide. Monetary benefit sharing under the IT is largely voluntary, except where commercial products are not freely available to others for research purposes, and is based on a sales royalty mechanism.

In most respects, Proclamation 482/2006 provides a typical interpretation of benefit sharing provisions that includes an indicative list of benefit sharing options but leaves all details to be the subjects of negotiation. In line with the ownership pattern established by the Proclamation, benefit sharing regarding genetic resources is largely the business of the IBC as the representative of the state. The exception is that communities are entitled to 50% of any such benefits accruing to the state, although it is not clear how such a 50% calculation will be arrived at, particularly in the case of in-kind benefits, nor how appropriate communities will be identified. Communities are directly engaged in determining, and benefiting from, benefit sharing where community knowledge is concerned. The main omission from the Proclamation appears to be that there is no consideration of Ethiopia's potential role as a consumer of genetic resources. However, the country is most likely to play this role in the context of agricultural materials that could mostly be catered for in regulations implementing the IT.

Proclamation 482/2006 and the informal seed sector

Having provided a broad overview of the relationship between the CBD, the IT and Ethiopia's Proclamation 482/2006, this section concludes by considering several issues that may impact the informal seed sector in Ethiopia but that have not come out clearly in the previous discussions. The first of these is the treatment of Ethiopian individuals and organizations, which revolves around three elements:

- i) sub-section 4.2(a) provides for the exemption of customary use and exchange of genetic resources and community knowledge among Ethiopian local communities;
- ii) sub-section 11.4 exempts state institutions with a statutory conservation mandate; and,
- iii) sub-section 15.1 provides for the special treatment, but not exemption, of Ethiopian research and higher learning institutions.

These three special treatment provisions clearly indicate that all other activities conducted by Ethiopians, including all actors from the private sector to local communities, are subject to authorization by the IBC. In the case of establishing farmer- or community-based seed production enterprises, which would seem an unlikely fit in any understanding of customary use and exchange, this means that

access to genetic resources requirements are going to apply. Admittedly, under the Proclamation the IBC has the flexibility to make the process of authorizing access relatively simple but, with the current text, this is not guaranteed or immediately apparent.

A further issue is the potential burden that the Proclamation places upon local communities. Local communities are entitled to a series of privileges and benefits under the Proclamation but they are to be identified on the basis of a series of criteria, where the community must (i) live in a distinct geographical area, and be (ii) custodian of a given genetic resource; or, (iii) creator of given community knowledge. The first of these is not problematic but the latter two, while possibly attractive from a rhetorical point of view, raise serious questions as to who will verify or certify that these criteria have been met and how might any resulting determinations be challenged? This is of particular concern when one considers that genuine local communities tend to be those most disadvantaged in terms of resources and access to legal systems and these criteria could be used to place quite strict conditions on their access to what are effectively affirmative action provisions.

A third and final issue is that, under Section 29, regional bodies are given some responsibilities in the monitoring of the implementation of the Proclamation in their respective jurisdictions. This section could, perhaps, be used to further develop a principle of decentralization and devolution. This might simultaneously make the community aspects of the Proclamation easier to implement and provide an opportunity to link the aspects of the Proclamation that are likely to impact the informal seed sector more directly with the administrative levels at which this sector is primarily intended to be active.

7.5 Opportunities for policy development supporting informal seed supply of local crops and varieties in Ethiopia*

Walter de Boef and Anthony J.G. van Gastel

Many seed policies and accompanying legal and regulatory frameworks are exclusively targeting formal seed supply, ignoring the informal seed system, even if the latter is the most dominant system in sub-Saharan African countries, including Ethiopia. Even though they have the objective to contribute to seed and food security, seed policies are often considered a constraint, particularly in targeting the support of informal seed supply. Barriers raised by policy and regulatory frameworks are met by alternative strategies directed at supporting informal seed supply, such as farmer- or community-

* The current section elaborates the analysis and recommendations of a workshop addressing policy issues organized 25-26 July 2007 in Addis Ababa, within the framework of the Tailor-Made Training Programme: “The improvement of farmer-based seed production and revitalizing informal seed supply of local crops and varieties in Ethiopia”.

based seed production, the establishment of community-based or small-scale seed enterprises, participatory approaches to plant breeding, and efforts supporting farmers' management and use of local crops and varieties.

In Ethiopia, many stakeholders and institutions play important roles in these frameworks on the one hand, and at the same time are involved in the development of such alternative strategies. At the federal level key stakeholders are various departments and services of the Ministry of Agriculture and Rural Development (MoARD), the Ethiopian Seed Enterprise (ESE), the Institute for Biodiversity Conservation (IBC), and the Ethiopian Institute for Agricultural Research (EIAR). At regional government levels, key stakeholders are the Bureau of Agriculture and Rural Development (BoARD), Regional Agricultural Research Institutes (RARIs) and Cooperative Promotion Agencies (CPUs). Other non-public stakeholders include NGOs, international projects and private seed companies. All stakeholders are embedded within the framework that poses constraints, and at the same time they are supporting the development of alternative strategies. This situation creates a demand for establishing a forum in which strategies for supporting seed supply, constraints in policy frameworks and requirements for policy change are discussed.

Within the Tailor-Made Training Programme (TMTP) "the improvement of farmers based seed production and revitalizing informal seed supply of local crops and varieties in Ethiopia" a policy workshop was organized in Addis Ababa, 25-26 July 2007, to address these topics. The convening partners were the ESE, Wageningen International and the ICARDA Seed Unit, and participants were representatives of all relevant stakeholders at both federal and regional levels, and representatives of the teams participating in the TMTP.

The general objective of the workshop was to address policy and regulatory frameworks related to genetic diversity and informal seed supply. The workshop aimed to contribute to the following: (i) raising awareness among stakeholders on informal seed supply and seed policies relevant to informal seed supply, including seed regulations, mechanisms for plant variety protection and the release of varieties, and biodiversity and genetic resource access laws; (ii) facilitating stakeholder interaction and linkage for sharing the experiences and structure of the training programme with stakeholders active in the seed and genetic resource policy arena at both the federal (MoARD, EIAR, ESE, IBC, NGOs) and regional (BoARD, NGOs, RARIs) levels; (iii) analysing and discussing the bottlenecks within the current seed and genetic resource policies and regulations; (iv) on the basis of this analysis, determining opportunities for the development of seed and genetic resource policies and regulations, and if required, re-adjustment at both federal and regional level; and (v) determining the responsibilities and pathways, and ensuring the commitment of stakeholders at federal and regional levels to realizing conducive seed and genetic resource policies and regulations supporting informal seed supply and the establishment of small seed enterprises. The workshop took the two key elements of the TMTP as leading perspectives, namely (a) supporting informal seed supply at the regional level, and (b) establishing small-scale and community-based seed enterprises. It is important to realize that the participants represented the full spectrum of stakeholders involved in policy development at federal and regional level, and in the

development of alternative strategies supporting seed supply. This section shares the outcome of the analysis and above all compiles the recommendations as formulated by the participants during the workshop.

Making policies supporting informal seed supply

The seed policy and seed law should be revised to accommodate and support the development of the informal seed sector, including the establishment of community-based and small-scale seed enterprises (CB/SSE). In this process of revising the law, one of the following options is recommended: (a) include additional section(s) or articles addressing the informal seed sector, or (b) develop a new proclamation.

Continued cultivation and use of local varieties and minor crops should be promoted through the National Policy on Biodiversity Conservation and Research. One mechanism to achieve this goal is to promote the establishment and strengthening of community-based organizations that particularly focus on those varieties and crops. Regional governments should implement conservation policies and strategies based on the federal conservation policy and strategies. Regional BoARDs, with the support of the IBC, should develop modalities for biodiversity registers.

Farmer and community-based seed production of local varieties and minor crops should be embedded in a revised national seed policy. The revision should be such that farmer seed production of local varieties and minor crops is recognized and promoted; incentives should include technical support and training. Policies should: (i) support access to credit for cultivation and seed production of local varieties and minor crops, (ii) strengthen farmers' market access for these seeds and their products, (iii) support processes of value addition and (iv) facilitate the development of relatively 'easy' procedures to recognize and denominate products of geographic origin. Efforts should be made to raise farmers' awareness on options and potentials encouraging the cultivation of local varieties and minor crops.

Decentralization (from federal to regional or local levels) *and increased farmer participation* should be embedded and included in a *revisited variety release system*. This revision is required to increase the system's efficiency and effectiveness. The process should be coordinated by the national variety release committee and handled within the framework of the national variety release rules and procedures. Special procedures and standards should facilitate the release of varieties for specific agro-ecological niches. Farmers' selection criteria and demands should be used in the testing of varieties and farmers should participate (through community-based organizations) in on-farm testing, defining criteria and standards, and decision making.

Basic seed should be available to seed producers at reasonable costs. To increase the availability of basic seed and the seed producers' access to it, research institutes should guarantee sufficient supply of breeders' and pre-basic seed of released varieties at reasonable cost. The ESE should guarantee availability of sufficient basic seed of released

varieties. For crops and varieties where no basic seed exists (minor crops, local varieties, non-released varieties), appropriate organizations should be allowed to provide seed for further multiplication (provided they can produce sufficient quantity and quality). Such organizations include the BoARD (through its nurseries), the IBC, community seed banks, NGOs, private sector companies, research institutions, community-based organizations, farmers, etc.

Seed quality control should be decentralized to regional levels following the provisions in the seed law (Article 22 and 30). This process of decentralization should include certification. Seed laboratories and capacity building are required to realize this process.

Mechanisms should be developed to support seed production on the principles of 'quality declared seed'. Field and laboratory seed quality standards should be examined and standards for seed produced in the informal sector should be different from those applied in the formal sector. The standards in these regulations should be based on the principles of 'quality declared seed'.

Various mechanisms should be developed and put into place to support the establishment of community-based and small-scale seed enterprises. The legal status of CB/SSEs should facilitate optimum access to incentives. CB/SSEs should be allowed to produce seed without registration and be supported through credit by NGOs and regional governments. Cooperative Promotion Agencies should provide legal advice and relevant market information at the woreda level. Capacity building should be the responsibility of regional governments and NGOs. Local BoARD institutions should facilitate linkages with the IBC, research institutions, the ESE, NGOs, financial institutions, input providers/industry and other stakeholders. The BoARDS should also provide assistance in promotion and marketing of quality seed at regional, zonal and woreda levels. Through the DAs and regional laboratories, the BoARDS should support CB/SSEs in: (i) the development of procedures for internal quality control; (ii) production of seed meeting the required quality standards; and (iii) training of members/associated farmers to meet these standards.

Opportunities in the way forward

The above recommendations should (i) be used when drafting and implementing regional strategies; (ii) be translated into rules, regulations and guidelines that can be implemented; (iii) be made widely available within the regions, and (iv) be translated into efforts at the grassroots level. To realize all these recommendations, capacity building at all levels is an important component of the support required.

There is a lot of demand for support for revision and decentralization. In order to meet the challenges these changes pose, and to transform policy, legal and regulatory frameworks from barriers into supportive structures, a complex process is envisioned. This process needs to include many stakeholders, and above all, decision and policy makers at federal and regional levels. The kind of sharing of experience (hybridization of ideas) between regional and federal staff and national and

international resource persons that occurred in the policy workshop and training programme should be continued, so as to form a creative forum for policy dialogue and development. All the stakeholders at the workshop committed themselves to policy change and action, considering seed as a major input and constraint in all regions. The important role of the informal sector in seed supply, food production, poverty alleviation and food security was confirmed during the workshop. This consideration should be better embedded in federal and regional policies: there is an urgent need to support the informal sector.

References

- ¹ The following reports have been used for section 1.1:
 - Reports on area and production for major crops, 2000-2007. Central Statistical Authority/Agency. Addis Ababa, Ethiopia.
 - Annual reports of the Ethiopian Seed Enterprise, 2000-2007. Addis Ababa, Ethiopia.
 - Crop variety register issue no. 9. Ministry of Agriculture and Rural Development 2006. Addis Ababa, Ethiopia.
 - Seed systems development project phase II. Part 1 Review of the national seed industry development. National Seed Industry Agency, 2001.
- ² Bishaw, Z., 2004. Wheat and barley seed systems in Ethiopia and Syria. PhD thesis. Wageningen, Wageningen University.
- ³ Sahlü, Y., 1999. Status and quality of barley seeds used by the Northern and Central Ethiopian farmers. MSc thesis. Amman, University of Jordan.
- ⁴ Central Statistical Authority, 2003. Ethiopian Agricultural Sample Enumeration, 2001/2002 (1994 E.C.) Results at country level. Report on socio-economic characteristics of the population in agriculture households, land use, and area and production of crops. Part 1. Addis Ababa, CSA.
Central Statistical Authority, 2003. Ethiopian Agricultural Sample Enumeration, 2001/2002 (1994 E.C.) Results at country level. Statistical report on farm management practices, livestock and farm implements. Part 2. Addis Ababa, CSA.
- ⁵ MoFED, 2006. Ethiopia: building on progress. A Plan for Accelerated and Sustainable Development to End Poverty (PASDEP). Addis Ababa, Ministry of Finance and Economic Development.
- ⁶ Ethiopian Seed Enterprise, 2000. Annual report. Addis Ababa, ESE.
- ⁷ Cooper, D., V. Renee and H. Hobbelink (Eds.), 1992. Growing diversity: genetic resources and local food security. London, Intermediate Technology Publications Ltd.
- ⁸ National Seed Industry Agency, 2002. Evaluation of the implementation of Farmer Based Seed Production and Marketing Scheme. Addis Ababa, NSIA.
- ⁹ National Seed Industry Agency, 2001. Seed Systems Development Project Phase II. Part 1 Review of the national seed industry development. Addis Ababa, NSIA.
- ¹⁰ McGuire, S., 2005. Getting genes: Rethinking seed system analysis and reform for sorghum in Ethiopia. PhD thesis. Wageningen, Wageningen University.
- ¹¹ Haugerud, A. and M.P. Collinson, 1990. Plants, genes, and people: Improving the relevance of plant breeding in Africa. *Experimental Agriculture* 26: 341-362.
- ¹² Almekinders, C.J.M. and N.P. Louwaars, 1999. Farmers' seed production. New approaches and practices. London, IT Publications.
- ¹³ Cromwell, E., S. Wiggins and S. Wentzel, 1993. Sowing beyond the state: NGOs and seed supply in developing countries. London, ODI.
- ¹⁴ Hodgkin, T., R. Rana, J. Tuxill, D. Balma, A. Subedi, I. Mar, D. Karamura, R. Valdivia, L. Collado, L. Latournerie, M. Sadiki, M. Sawadogo, A.H.D. Brown and D.I. Jarvis, 2007. Seed systems and crop genetic diversity in agroecosystems. [In] Jarvis, D.I., C. Padoch

- and H.D. Cooper. *Managing biodiversity in agricultural ecosystems*. New York, Columbia University Press: pp. 77-116.
- 15 Ceccarelli, S. and S. Grando, 1999. Decentralised participatory plant breeding. *ILEIA Newsletter* 15 (3/4): 37-37.
- 16 Chambers, R., 2006. Notes for participants in PRA-PLA familiarisation workshops in 2006. Brighton, IDS.
- 17 Cohen, J.M. and N. Uphoff, 1977. Rural development participation: concepts and measures for project design, implementation and evaluation. Ithaca, New York, Cornell University, Rural Development Committee.
- 18 Clayton, A., P. Oakley and B. Pratt. 1997. Empowering people: a guidebook to participation. New York, UNDP.
- 19 Modified from: Pimbert, M.P. and J.N. Pretty, 1997. Parks, people and professionals: putting "participation" into protected area management. [In] Ghimire, K.B. and M.P. Pimbert (Eds.). *Social change and conservation. Environmental politics and impacts of national parks and protected areas*. London, Earthscan Publications: pp. 298-330.
- 20 Pretty, J., 1994. Alternative systems of inquiry for sustainable agriculture. *IDS Bulletin* 25 (2): 37-48.
- 21 Chambers, R., 2002. Participatory workshops: a sourcebook of 21 sets of ideas and activities. London, Earthscan Publications.
- 22 Kolb, D.A. and R. Fry. 1975. Toward an applied theory of experiential learning. [In] Cooper, C. (Ed.). *Theories of Group Process*. London, John Wiley.
- 23 De Boef, W.S. and M.H. Thijssen, 2007. Participatory tools working with crops, varieties and seeds. A guide for professionals applying participatory approaches in agrobiodiversity management, plant breeding and seed sector development. Wageningen, Wageningen International.
- 24 McQuire, S.J., 2007. Vulnerability in farmer seed systems: farmer practices for coping with seed insecurity for sorghum in Eastern Ethiopia. *Economic Botany* 61 (3): 221-222.
- 25 Berkes, F. and V. Folke (Eds.), 1998. Linking social and ecological systems. Management practices and social mechanisms for building resilience. Cambridge, Cambridge University Press.
- 26 Gunderson, L., C.S. Holling and S. Light, 1995. Barriers and bridges to the renewal of ecosystems and institutions. New York, Columbia University Press.
- 27 Almekinders, C.J.M., G. Thiele and D.L. Danial, 2006. Can cultivars from participatory plant breeding improve seed provision to small-scale farmers? *Euphytica* (2007) 153: 363-372.
- 28 Bishaw, Z. and M. Turner, 2007. Linking participatory plant breeding to the seed supply system. *Euphytica*, retrieved 3 April 2008 from: <http://www.springerlink.com/content/11416v02174kj215/fulltext.pdf>
- 29 Almekinders, C.J.M. and W. S. de Boef (Eds.), 2000. Encouraging diversity. The conservation and development of plant genetic resources. London, IT Publications.
- 30 Dyer, G.A. and J.E. Taylor, 2008. A crop population perspective on maize seed systems in Mexico. *Proceedings of the National Academy of Sciences* 105(2): 470-475.
- 31 Greve, J.E. van S., 1983. Safe storage for small quantities of seed. *Harvest* 9: 5-10.

- ³² Wright, M., T. Donaldson, E. Cromwell and J. New, 1994. The retention and care of seeds by small farmers. Chatman, NRI.
- ³³ Aderajew Haddis and T. Berg, 2006. Selectors and non-selectors: agricultural and socioeconomic implications of on-farm seed selection in Ethiopia. *Plant Genetic Resources Newsletter* 145: 1-10.
- ³⁴ Chaudhary, P., D. Gauchan, R.B. Rana, B.R. Sthapit and D.I. Jarvis, 2004. Potential loss of rice landraces from a Tarai community in Nepal: a case study from Kachorwa, Bara. *Plant Genetic Resources Newsletter* 137: 14-21.
- ³⁵ Sperling, L. 2002. Emergency seed aid in Kenya. Some case study insights from lessons learned during the 1990s. *Disasters* 26 (4): 283-287.
- ³⁶ Sperling, L. and H.D. Cooper, 2003. Understanding seed systems and strengthening seed security. [In] Sperling, L., T. Osborn and D. Cooper (Eds). Towards effective and sustainable seed relief activities, Report on the Workshop on Effective and Sustainable Seed Relief Activities, 26-28 May 2003. *FAO Plant Production and Protection Paper* 181. Rome, FAO.
- ³⁷ Longley, C., R. Jones, M.H. Ahmed, and P. Audi, 2001. Supporting local seed systems in southern Somalia: a developmental approach to agricultural rehabilitation in emergency situations. *AGREN network paper* no 115.
- ³⁸ FAO, 2005. FAOstat data. Last update February 2005. Web link: www.faosta.fao.org/faostat.
- ³⁹ David, S., S. Kasozi and C. Wortmann, 1997. An investigation of alternative bean seed marketing channels in Uganda. *Network on Bean Research in Africa, Occasional Publications Series*, No. 19. Kampala, CIAT.
- ⁴⁰ Rubyogo, J.C., L. Sperling and T. Assefa, 2007. A new approach in facilitating farmers to access bean seed. *LEISA Magazine* 23 (2): 27-30.
- ⁴¹ Sperling, L. 1994. Analysis of bean seed channels in the Great Lakes Region: South Kivu, Zaire, Southern Rwanda, and select bean-growing areas zones of Burundi. *Network on Bean Research in Africa, Occasional Publications Series*, no. 13. Butare, CIAT/ RESAPAC.
- ⁴² Jones R.B., P.A. Audi and R. Tripp, 2001. The role of informal seed systems in disseminating modern varieties. The example of pigeon pea from semi-arid areas of Kenya. *Experimental Agriculture* 37: 539-548
- ⁴³ Qualset, C.O., A.B. Damania, A.C.A. Zanatta, and S.B. Brush, 1997. Locally based crop plant conservation. [In] Maxted, N., B.V. Ford-Lloyd and J.G. Hawkes (Eds.). *Plant genetic conservation. The in situ approach*. London, Chapman and Hall: pp. 160-175.
- ⁴⁴ Monica Opole, personal communication.
- ⁴⁵ Spellerberg, I.F. and S.R. Hardes, 1992. *Biological conservation*, Cambridge, Cambridge University Press.
- ⁴⁶ UNEP, 1992. *Convention on Biological Diversity*. Nairobi, United Nations Environment Programme.
- ⁴⁷ Berg, T., Å. Bjørnstad, C. Fowler, and T. Krøppa, 1991. Technology options and the gene struggle. NORAGRIC Occasional Papers Series C. Ås, Norwegian Centre of International Agricultural Development, Agricultural University of Norway.

- 48 Ertug Firat, A. and A. Tan, 1997. *In situ* conservation of genetic diversity in Turkey. [In] Maxted, N., B.V. Ford-Lloyd and J.G. Hawkes (Eds.). *Plant genetic conservation. The in situ approach*. London, Chapman and Hall: pp. 254-262.
- 49 Worede, M. T. Tesemma and R. Feyissa, 1999. Keeping diversity alive: an Ethiopian perspective. [In] Brush, S.B. (ed.). *Genes in the field. On-farm conservation of crop diversity*. Boca Raton FL, Lewis: pp. 143-163.
- 50 Hardon, J.J. and W.S. de Boef, 1993. Linking farmers and plant breeders in local crop development. [In] de Boef, W.S., K. Amanor, and K. Wellard with A. Bebbington (Eds.). *Cultivating knowledge. Genetic diversity, farmer experimentation and crop research*. London, IT Publications: pp. 64-71.
- 51 Almekinders, C.J.M., N.P. Louwaars and G.H. de Bruin, 1994. Local seed systems and their importance for an improved seed supply in developing countries. *Euphytica* 78: 207-216.
- 52 McGuire, S., 2001. Seed systems health indicators: A note. [In] Sperling, L. (Ed.). *Targeting seed aid and seed systems interventions; strengthening small farmer seed systems in East and Central Africa. Proceedings of a workshop held in Kampala, Uganda, 21-24 June 2000*. Kampala, CIAT.
- 53 Weltzien, E. and K. vom Brocke, 2001. Seed systems and their potential for innovation: conceptual framework for analysis. [In] Sperling, L. (Ed.). *Targeting seed aid and seed systems interventions; strengthening small farmer seed systems in East and Central Africa. Proceedings of a workshop held in Kampala, Uganda, 21-24 June 2000*. Kampala, CIAT.
- 54 Baniya, B., A. Subedi, R.B. Rana, R.T. Tiwari, P. Chaudhary, P. Shrestha, R.B. Yadav, D. Gauchan, and B.R. Sthapit, 2003. What are the processes used to maintain genetic diversity on farm? [In] Gauchan, D., B.R. Sthapit and D.I. Jarvis (Eds.). *Agrobiodiversity conservation on farm: Nepal's contribution to a scientific basis for national policy recommendations*. Rome, IPGRI.
- 55 Hastings, A. and S. Hartison, 1994. Metapopulation dynamics and genetics. *Annual Review of Ecological Systems* 25: 167-88.
- 56 Sperling L. (Ed.), 2001. Targeting seed aid and seed systems interventions; strengthening small farmer seed systems in East and Central Africa. Proceedings of a workshop held in Kampala, Uganda, 21-24 June 2000. Kampala, CIAT.
- 57 Shrestha, P., A. Subedi, S. Sthapit, D. Rijal, S.R. Gupta and B.R. Sthapit, 2006. Community seedbank: Reliable and effective option for agricultural biodiversity conservation. Good practice No. 10. [In] Sthapit, B.R., P. Shrestha and M. Upadhyay (Eds.). *Good practices. On-farm management of agricultural biodiversity in Nepal*. Kathmandu, NARC, LI-BIRD, IPGRI and IDRC.
- 58 Balcha, G., T.R. Pearce and A. Demissie, 2003. Biological diversity and current *ex situ* conservation practices in Ethiopia. [In] Smith, R.D., J.B. Dickie, S.H. Linington, H.W. Pritchard and R.J. Probert (Eds.). *Seed conservation: turning science into practice*. Kew, Royal Botanic Gardens: pp 847-856.
- 59 Yallew, A., Hailye, A., and H. Hassen, 1998. Farmers' food habits and barley utilization in Northwest Ethiopia. [In] Yirga, C., F. Alemayehu and W. Sinebo (Eds.). *Barley-based farming systems in the Highlands of Ethiopia*. Addis Ababa, EARO: pp. 107-112.
- 60 Mendoza, G., 1995. A primer on marketing channels and margins. *Grain Markets Research Project, Working Paper 6*. Addis Ababa, MEDaC.

- ⁶¹ Wolday, A., 1991. Improved seed marketing and adoption in Ethiopia. *Ethiopian Journal of Agricultural Economics* 3(1): 41–87.
- ⁶² Demissie, A., 1991. A decade of germplasm exploration and collecting activities by the Plant Genetic Resources Center/Ethiopia. [In] Engels, J.M.M., J.G. Hawkes and Melaku Worede (Eds.). *Plant genetic resources of Ethiopia*. Cambridge, Cambridge University Press: pp. 202-217.
- ⁶³ Ceccarelli, S. and S. Grando, 2002. Plant breeding with farmers requires testing the assumptions of conventional plant breeding: Lessons from the ICARDA barley program. [In] Cleveland, D.A., and D. Soleri (Eds.). *Farmers, scientists and plant breeding: integrating knowledge and practice*. Wallingford, CAB International: pp. 297–332.
- ⁶⁴ Tanto, T. and G. Balcha, 2003. Terminal report on “A Dynamic Farmer-based Approach to the Conservation and of Ethiopia’s Plant Genetic Resources” Project. Addis Ababa, IBC and UNDP.
- ⁶⁵ Tanto, T. and F. Kebebew, 2003. Farmer-based on-farm *in situ* conservation of crop diversity in Ethiopia (Monograph). Addis Ababa, IBC and UNDP.
- ⁶⁶ Melaku Worede, 1997. Ethiopian *in situ* conservation. [In] Maxted, N., Ford-Lloyd, B.V. and J.G. Hawkes (Eds.). *Plant genetic conservation, the in situ approach*. London, Chapman & Hall, pp. 290-301.
- ⁶⁷ Polreich, S., 2005. Assessing the influence of the community seedbank system on the abundance of wheat landraces in Ethiopia: a perspective for on-farm conservation. MSc-thesis. Göttingen, Georg-August-University.
- ⁶⁸ Tesfaye Tesemma, T. and E. Bechere, 1998. Developing elite durum wheat landrace selections (composites) for Ethiopian peasant farm use: raising productivity while keeping diversity alive. *Euphytica* 102: 323-328.
- ⁶⁹ Asefa Bayeta, personal communication.
- ⁷⁰ Tsegaw Getabalew, CSB Wore Ilu, personal communication.
- ⁷¹ Regassa Feyissa, personal communication.
- ⁷² Brown, A.H.D. and C.L. Brubaker, 2002. Indicators for sustainable management of plant genetic resources: How well we are doing? [In] Engels, J.M.M., V. Ramanatha Rao, A.H.D. Brown and M.T. Jackson (Eds.). *Managing plant genetic resources*. Rome, IPGRI. pp. 249-262.
- ⁷³ Worede, M., 1997. Ethiopian *in situ* conservation. [In] Maxted, N., Ford-Lloyd, B.V. and J.G. Hawkes (Eds.). *Plant genetic conservation, the in situ approach*. London, Chapman & Hall, pp. 290-301.
- ⁷⁴ Mburu, J. and E. Wale, 2004. Local organizations involved in the conservation of crop genetic resources: Conditions for their emergence and success in Ethiopia and Kenya. *Genetic Resources and Crop Evolution* 53 (3): 613-629.
- ⁷⁵ Tesemma, T. and E. Bechere, 1998. Developing elite durum wheat landrace selections (composites) for Ethiopian peasant farm use: raising productivity while keeping diversity alive. *Euphytica* 102: 323-328.
- ⁷⁶ Sthapit, B., 2006. An improved tool to assess local crop diversity. [In] Bioversity International. *Annual Report 2005*. Rome, Bioversity International.

- 77 Subedi, A., P. Chaudhary, B. Baniya, R. Rana, R.K. Tiwari, D. Rijal, D.I. Jarvis, and B.R. Sthapit, 2003. Who maintains crop genetic diversity and how: implications for on-farm conservation and utilization. *Culture & Agriculture* 25(2): 41-50.
- 78 Tapia, M.E. and A. Rosa, 1993. Seed fairs in the Andes: a strategy for local conservation of plant genetic resources. [In] W.S. de Boef, K. Amanor and K. Wellard with A. Bebbington (Eds.). *Cultivating knowledge: genetic diversity, farmer experimentation and crop research*. London, IT Publications: pp. 111-119.
- 79 Adhikari, A., R.B. Rana, R. Gautam, A. Subedi, M.P. Upadhyay, P. Chaudhary, I. Paudel, D. Rijal and B.R. Sthapit, 2006. Diversity fair: Promoting exchange of knowledge and germplasm. [In] Sthapit, B.R., P.K. Shrestha and M.P. Upadhyay (Eds.), 2006. Good practices: On-farm management of agricultural biodiversity in Nepal, NARC, LI-BIRD, IPGRI and IDRC.
- 80 Sthapit, B.R., D. Rijal, N.N. De and D.I. Jarvis, 2003. A role for diversity fairs: Experiences from Nepal and Vietnam. [In] CIP-UPWARD. *Conservation and sustainable use of agricultural biodiversity: A source book Vol II: Strengthening local management of agricultural biodiversity*. Los Baños, CIP-UPWARD: pp. 271-276.
- 81 Subedi, A., B.R. Sthapit, M.P. Upadhyay and D. Gauchan (Eds.), 2005. Learning from community biodiversity register in Nepal. Proceedings of the National Workshop 27-28 Oct 2005, Khumaltar, Nepal. Kathmandu, NARC, LI-BIRD, IPGRI and IDRC.
- 82 Joshi, K.D. and B.R. Sthapit, 1990. Informal Research and Development (IRD): A new approach to research and extension. *LARC Discussion Paper 1990/4*. Pokhara, Lumle Agricultural Research Centre.
- 83 Joshi, K. and J.R. Witcombe, 2002. Participatory variety selection in rice in favourable agricultural environments – A comparison of two methods assessed by varietal adoption. *Euphytica* 127: 445-458.
- 84 Almekinders, C. and J. Hardon (Eds.). 2006. Bringing farmers back into breeding. experiences with Participatory Plant Breeding and challenges for institutionalization. *Agromisa Special 5*. Wageningen, Agromisa.
- 85 Bertuso, A., G. Ginogaling and R. Salazar. 2000. Community genebanks: the experiences of CONSERVE in the Philippines. [In] Almekinders C.J.M. and W.S. de Boef (Eds.). *Encouraging diversity: the conservation and development of plant genetic resources*. London, IT Publications: pp. 117-122.
- 86 SEARICE. 2007. Community Plant Genetic Resources conservation, development and use: Interventions and innovations in SEARICE's community projects. [In] Rice Watch and Action Network. *Making our own choices for sustainable farming: documentation of selected rice farming methods*. Manila, Rice Watch and Action Network.
- 87 The following review articles were used as inputs for the current section:
- Almekinders, C.J.M and A. Elings, 2003. Collaboration of farmers and breeders: participatory crop improvement in perspective. *Euphytica* 122: 425-438.
 - Subedi, A., S. Gyawali, R. Gautam, B.R. Sthapit, P. Chaudhary and S. Poudel, 2003. Participatory approaches to crop improvement in Nepal. [In] CIP-UPWARD. *Conservation and sustainable use of agricultural biodiversity: a source book*. Los Baños, CIP-UPWARD, pp. 354-361.
 - Witcombe, J.R., K.D. Joshi, S. Gyawali, A.M. Musa, C. Johansen, D.S. Virk and B.R. Sthapit, 2005. Participatory plant breeding is better described as highly client-oriented

- plant breeding. I. Four indicators of client-orientation in plant breeding. *Experimental Agriculture*. 41: 1-21.
- Witcombe, J.R., S. Gyawali, S. Sunwar, B.R. Sthapit and K.D. Joshi, 2006. Participatory plant breeding is better described as highly client-oriented plant breeding. II. Optional farmer collaboration in segregating generations. *Experimental Agriculture* 42: 79-90.
- ⁸⁸ Lipton, M. and T. Longhurst, 1989. *New Seeds and Poor People*. London, Unwin Hyman.
- ⁸⁹ Sperling, L., U. Scheidegger and R. Buruchara, 1996. Designing seed systems with small farmers: principles derived from bean research in the Great Lakes Region of Africa, *Agricultural Research and Extension Network Paper 60*. London, ODI.
- ⁹⁰ Ceccarelli, S. and S. Grando, 2005. Decentralized participatory plant breeding. A case from Syseria. [In] Gonsalves, J., T. Becker, A. Braun, D. Campilian, H. de Chavez, E. Fajber, M. Kapiriri, J. Rivaca-Caminade, and R. Vernooy (Eds.). *Participatory research and development for sustainable agriculture and natural resource management I*. Cali, CIAT-PRGA.
- ⁹¹ Bänziger, M., F.J. Betrán, and H.R. Lafitte, 1997. Efficiency of high nitrogen selection environments for improving maize for low nitrogen target environments. *Crop Science* 37: 1103–1109.
- ⁹² Ceccarelli, S., S. Grando, and J. Hamblin, 1992. Relationship between barley grain yields measured in low- and high-yielding environments. *Euphytica* 64: 49–58.
- ⁹³ Chiffolleau, Y. and D. Desclaux, 2006. Participatory plant breeding: the best way to breed for sustainable agriculture? *International Journal of Agricultural Sustainability* 4: 119-130.
- ⁹⁴ Thiele, G., G. Gardner, R. Torrez and J. Gabriel, 1997. Farmer involvement in selection of new varieties: potatoes in Bolivia. *Experimental Agriculture* 33: 1–16.
- ⁹⁵ Witcombe, J.R., A. Joshi, K.D. Joshi, and B.R. Sthapit, 1996. Farmer participatory crop improvement. I. Varietal selection and plant breeding methods and their impact on biodiversity. *Experimenting Agriculture* 32: 445–460.
- ⁹⁶ Subedi, A., S. Gyawali, R. Gautam, B.R. Sthapit, P. Chaudhary and S. Poudel, 2003. Participatory approaches to crop improvement in Nepal. [In] CIP-UPWARD. *Conservation and sustainable use of agricultural biodiversity: a source book*. Los Baños, CIP-UPWARD, pp. 354-361.
- ⁹⁷ Witcombe, J.R., K.D. Joshi, S. Gyawali, A.M. Musa, C. Johansen, D.S. Virk and B.R. Sthapit, 2005. Participatory plant breeding is better described as highly client-oriented plant breeding. I. Four indicators of client-orientation in plant breeding. *Experimental Agriculture*. 41: 1-21.
- ⁹⁸ Witcombe, J.R., S. Gyawali, S. Sunwar, B.R. Sthapit and K.D. Joshi, 2006. Participatory plant breeding is better described as highly client-oriented plant breeding. II. Optional farmer collaboration in segregating generations. *Experimental Agriculture* 42: 79-90.
- ⁹⁹ Almekinders, C.J.M and A. Elings, 2003. Collaboration of farmers and breeders: participatory crop improvement in perspective. *Euphytica* 122: 425–438.
- ¹⁰⁰ Witcombe, J. R., A. Joshi, and S. N. Goyal, 2003. Participatory plant breeding in maize: a case study from Gujarat, India. *Euphytica* 130: 413–422.
- ¹⁰¹ Gemechu K. and Adugna W., 2004. Genetic uniformity of crop cultivars: challenges and opportunities. *Sebil* 10: 1-9.

- ¹⁰² Tsedeke A., 2006. Focusing agricultural research to address development needs: the way I see it. [In] Tsedeke A. (Ed.). *Successes with value chain. Proceedings of scaling up/out agricultural technologies in Ethiopia: an International Conference, 9-11 May 2006, Addis Ababa*. Addis Ababa, EIAR, pp. 1-20.
- ¹⁰³ Gemechu K., 2007. Concerns on mismatches between environments of selection and production of crop varieties in Ethiopia. *East African Journal of Sciences* 1(2): 93-103.
- ¹⁰⁴ Ceccarelli, S., 2001. Decentralized-participatory plant breeding: adapting crops to environments and clients. Aleppo, ICARDA.
- ¹⁰⁵ Mangione D., S. Senni, M. Puccioni, S. Grando and S. Ceccarelli, 2006. The cost of participatory barley breeding. *Euphytica* 150: 289-306.
- ¹⁰⁶ Mekbib F., 1997. Farmer participation in common bean genotype evaluation. *Experimental Agriculture* 33: 399-408.
- ¹⁰⁷ Belay G., Tefera H., Tadesse B., Metaferia G., Jarra D. and Tadesse T., 2005. Participatory variety selection in the Ethiopian cereal teff (*Eragrostis teff*). *Experimental Agriculture* 42: 91-101.
- ¹⁰⁸ Weltzien, E., M. Smith, L.S. Meitzner and L. Sperling, 1999. Technical and institutional issues in participatory plant breeding - from the perspective of formal plant breeding: a global analysis of issues, results, and current experience. *CGLAR System-wide programme on participatory research and gender analysis for technology development and institutional innovation. Working Document No 3*. Cali, CIAT/PRGA.
- ¹⁰⁹ Ceccarelli, S., S. Grando, R. Tutwiler, J. Baha, A.M. Martini, H. Salahieh, A. Goodchild and M. Michael, 2000. A methodological study on participatory barley breeding. I. Selection Phase. *Euphytica* 111: 91-104.
- ¹¹⁰ Horne, P.M. and W.W. Stur, 1997. Current and future opportunities for introduced forages in smallholder farming systems of South-East Asia. *Tropical Grasslands* 31(4): 359-363.
- ¹¹¹ Gepts, P. and D. Debouck, 1991. Origin, domestication and evolution of common bean (*P. vulgaris* L.) [In] Van Schoonhoven, A. and O. Voyset (Eds.) *Common beans: research for crop improvement*. Wallingord, CABI and CIAT, Cali, pp. 7-53.
- ¹¹² CSA, 2004. Agricultural sample survey 2003/2004. Report on farm management practices. Private peasant holdings, Meher season. *Statistical Bulletin no 305*. Addis Ababa, CSA.
- ¹¹³ BoARD (Bureau of Agriculture and Rural Development), 2005. Annual evaluation report of cereal production in Tigray. Mekelle, BoARD.
- ¹¹⁴ Snapp, S., 1999. Mother and baby trials: a novel trial design being tried out in Malawi. *Target Newsletter of the Southern Africa Soil Fertility Network* 17: 8-10.
- ¹¹⁵ Following the methods explained by Christinck, A., E. Weltzien and V. Hoffmann (Eds.), 2005: Setting breeding objectives and developing seed systems with farmers. A handbook for practical use in participatory plant breeding projects. Weikersheim, Margraf Publishers.
- ¹¹⁶ Virk, D.S., D.N. Singh, S.C. Prasad, J.S. Gangwar, and J.R. Witcombe, 2003. Collaborative and consultative participatory plant breeding of rice for the rainfed uplands of eastern India. *Euphytica* 132(1): 95-10.
- ¹¹⁷ Ceccarelli, S., 1994. Specific adaptation and breeding for marginal conditions. *Euphytica* 77, 205-219.

- 118 Ceccarelli, S., 1996. Positive interpretation of genotype by environment interactions in relation to sustainability and biodiversity. [In] Cooper, M. and G.L. Hammer (Eds.). *Plant adaptation and crop improvement*. Wallingford, CABI, pp. 467-486.
- 119 Grando, S., R. von Bothmer and S. Ceccarelli, 2001. Genetic diversity of barley: use of locally adapted germplasm to enhance yield and yield stability of barley in dry areas. [In] Cooper, H.D., C. Spillane and T. Hodgkin (Eds.). *Broadening the genetic base of crop production*. New York/Rome, CABI, FAO and IPGRI, pp. 351-372.
- 120 Sinebo, W., 2002. Yield relationships of barleys grown in a tropical highland environment. *Crop Science* 42: 428-437.
- 121 Adapted from Humphries, S., O. Gallardo, J. Jimenez, F. Sierra with members of the Association of CIALs of Yorito, Sulaco and Victoria, 2005. Linking small farmers to the formal research sector: lessons from a participatory bean breeding programme in Honduras. *AgREN Network Paper*. 142, London, ODI.
- 122 BUCAP, 2002. Field guide: Farmers' field school for rice plant genetic resources conservation, development and use. Manila, SEARICE.
- 123 Smolders, H. and E. Caballada (Eds.), 2006. Field guide for participatory plant breeding in farmer field schools. *PEDIGREA publication*. Wageningen, CGN.
- 124 Smolders, H., 2006. Enhancing farmers' role in crop development; framework information for participatory plant breeding in farmer field schools. *PEDIGREA publication*. Wageningen, CGN.
- 125 Pelegrina W., A.D. Arnejo, N. Pradhan, P. Giri, P. Xangsayapan, C. Bounphanousay and S.T.B. Minh, 2006. BUCAP and CBDC: Experiences and challenges of a Southeast Asian road to farmer plant breeding; BUCAP country cases. [In] Almekinders, C. and J. Hardon (Eds.). *Bringing farmers back into breeding. Experiences with participatory plant breeding and challenges for institutionalisation. Agromisa Special 5*. Wageningen, Agromisa, pp 103-116.
- 126 Dung N.T and W. R. Pelegrina, 2003. Managing biodiversity under changing market and agricultural production systems of Vietnam: The use of farmers fields schools approach. [In] CIP-UPWARD, 2003. *Farmer field schools: emerging issues and challenges*. Los Baños, CIP-UPWARD, pp 406-412.
- 127 Visser B., A. Bertuso, H. Smolders and N. Dano, 2006. PEDIGREA: Using the farmer field school concept and integrating marketing issues in participatory plant breeding of rice and local vegetables. [In] Almekinders, C. and J. Hardon (Eds.). *Bringing farmers back into breeding. Experiences with participatory plant breeding and challenges for institutionalisation. Agromisa Special 5*. Wageningen, Agromisa, pp. 117-134.
- 128 Meijerink, G., H. Smolders, S. Sours and S. Pou, 2005. Recovering biodiversity knowledge. *LEISA Magazine* 21(2): 24-25.
- 129 Pandey, S., 1998. Varietal development: conventional plant breeding. [In] Morris, M.L. (Ed.). *Maize Seed Industries in Developing Countries*. Mexico, CIMMYT.
- 130 Jones, R., 2007. Seed enterprise enhancement and development services (SEEDS) to support the commercialization of publicly-developed varieties in Africa. Biotechnology, Breeding and Seed Systems for African Crops. 3rd General Meeting, March 26-29, 2007. Maputo.
- 131 Dominguez, C., 2005. The basic seed unit of IIAM: USEBA. A strategy to strengthen the development of the seed sector in Mozambique. [In] CIMMYT. *New seed initiative for maize in Southern Africa. Annual Report 2005*. Harare, CIMMYT.

- 132 Mkhari, J.J., M.R. Matlebjane, K.P. Dlomu, N.D. Mudua and K. Mashingaidze, 2006. Case study of a community-based seed production scheme in two Districts of the Limpopo Province, South Africa. [In] Setimela, P.S. and P. Kosina (Eds.). *Strategies for Strengthening and Scaling up Community-based Seed Production*. Mexico, CIMMYT.
- 133 Zulu, E.D. and E. Goldschagg, 2005. Overview and progress in the harmonization of seed laws in SADC. [In] CIMMYT. *New seed initiative for maize in Southern Africa. Annual Report 2005*. Harare, CIMMYT.
- 134 Krull, C.F., J.M. Prescott and C.W. Crum, 1998. Seed marketing and distribution. [In] Morris, M.L. (Ed.). *Maize seed industries in developing countries*. Mexico, CIMMYT.
- 135 De Vries, J., and G. Toenniessen, 2002. Seed systems: reaching the poor in numbers. Wallingford, CABI.
- 136 Rohrbach, D., 2006. Relief seed: simply another distribution method? [In] CIMMYT. *New Seed Initiative for Maize in Southern Africa. Annual Report 2006*. Harare, CIMMYT.
- 137 Bishaw, Z. and A.J.T. van Gastel, 2008. ICARDA's approach to seed delivery in less favorable areas through village-based seed enterprises: conceptual and organizational issues. *Journal of New Seed*, in press.
- 138 Tripp, R., 2000. Strategies for seed system development in sub-Saharan Africa: a study of Kenya, Malawi, Zambia and Zimbabwe. *ICRISAT/ODI Working paper series no. 2*. Bulawayo, ICRISAT; London, ODI.
- 139 David, S., 1998. Producing bean seed: Handbooks for small-scale seed producers. Handbook 1. *Network on Bean Research in Africa. Occasional Publications Series no. 29*. Kampala, CIAT.
- 140 David, S. and B. Oliver, 2002. Business skills for small-scale seed producers: Handbooks for small-scale seed producers. Handbook 2. *Network on Bean Research in Africa, Occasional Publications Series no. 36*. Kampala, CIAT.
- 141 Wiggins, S. and E. Cromwell, 1995. NGOs and seed provision to smallholders in developing countries. *World Development* 23: 413-422.
- 142 Cromwell, E., 1991. Sustaining the Sustainable. *Seedling* 10(3). Retrieved 3 April 2008, from: <http://www.grain.org/seedling/?id=366>.
- 143 Douglas, J., 1980. Successful seed programmes. A planning and management guide. Boulder, Westview Press.
- 144 Louwaars, N.P., 2005. Seed laws: biases and bottlenecks. *Seedling*, July 2005: 3-7.
- 145 Tripp, R. and N. Louwaars, 1998. Seed regulation: choices on the road to reform. *Food Policy* 22 (5): 433-446.
- 146 Louwaars, N., R. Tripp and D. Eaton, 2006. Public research in plant breeding and intellectual property rights: a call for new institutional policies. *Agricultural & Rural Development Notes # 12*. Washington, World Bank.
- 147 Louwaars, N.P., 2007. Seeds of confusion. The impact of policies on seed systems. PhD thesis. Wageningen, Wageningen University. <http://library.wur.nl/wda/dissertations/dis4307.pdf>
- 148 Louwaars, N.P., 2007. Tailoring rights regimes in biotechnology; introducing DRIPS next to TRIPS. *Tailoring Biotechnologies* 3 (2): 99-114.
- 149 See <ftp://ftp.fao.org/ag/cgrfa/it/ITPGRe.pdf>

- ¹⁵⁰ World Bank, 2006. Intellectual property rights. Designing regimes to support plant breeding in developing countries. *World Bank Agriculture and Rural Development. Report # 3551*. Washington, World Bank.
- ¹⁵¹ Salazar, R., N. Louwaars and B. Visser, 2007. Protecting farmers' new varieties: new approaches to rights on collective innovations in plant genetic resources. *CAPRI Working Paper # 45*. Washington, IFPRI.
- ¹⁵² Rangnekar, D., 2007. Assessing the economic implications of different models for implementing the requirement to protect plant varieties: A case study of Kenya. Available at <www.ip4development.org>, website last checked August, 2007.