

**Protein and energy nutrition of marine gadoids,  
Atlantic cod (*Gadus morhua* L.) and haddock  
(*Melanogrammus aeglefinus* L.)**

**Sean Michael Tibbetts**

### **Thesis committee**

#### **Thesis supervisors**

Prof. dr. Santosh P. Lall  
National Research Council Canada  
Professor Dalhousie University, Halifax, Canada

Prof. dr. Johan A.J. Verreth  
Professor of Aquaculture and Fisheries  
Wageningen University

#### **Thesis co-supervisor**

Dr. Johan W. Schrama  
Associate professor, Aquaculture and Fisheries Group  
Wageningen University

#### **Other members**

Prof. dr. Wouter H. Hendriks	(Wageningen University, The Netherlands)
Prof. dr. Margareth Øverland	(Aquaculture Protein Centre, Ås, Norway)
Dr. Sadasivam Kaushik	(Institut National de la Recherche Agronomique, St Pée sur Nivelles, France)
Dr. Machiel C. Blok	(Product Board Animal Feed, The Hague, The Netherlands)

This research was conducted under the auspices of the graduate school: Wageningen Institute of Animal Sciences (WIAS)

**Protein and energy nutrition of marine gadoids, Atlantic cod (*Gadus morhua* L.) and haddock (*Melanogrammus aeglefinus* L.)**

**Sean Michael Tibbetts**

**Thesis**

submitted in fulfilment of the requirements for the degree of doctor  
at Wageningen University  
by the authority of the Rector Magnificus  
Prof. dr. M.J. Kropff,  
in the presence of the  
Thesis Committee appointed by the Academic Board  
to be defended in public  
on Tuesday 17 January 2012  
at 4 p.m. in the Aula.

Sean Michael Tibbetts

Protein and energy nutrition of marine gadoids, Atlantic cod (*Gadus morhua* L.) and haddock (*Melanogrammus aeglefinus* L.), 221 pages.

Thesis, Wageningen University, Wageningen, NL (2012)

With references and with summary in English and Dutch

ISBN: 978-94-6173-135-7

The research described in this thesis was financially supported by the National Research Council of Canada, Institute for Marine Biosciences (Halifax, Nova Scotia, Canada) with additional funding from Heritage Aquaculture Limited (St. George, New Brunswick, Canada) and the National Research Council of Canada, Industrial Research Assistance Program (Halifax, Nova Scotia, Canada). The fish used in these research studies were handled and cared for in accordance with the Canadian Council on Animal Care's Guidelines on the Care and Use of Fish in Research, Teaching and Testing (2005).

This thesis is dedicated to my sons, Eryn Daniel (born November 30, 2006) and Liam Alexander (born September 16, 2010). Your smiles and laughs have brought me great joy and happiness and you have given me more focus, life-perspective and ambition than you can imagine.

*You boys are my life's greatest achievement!*

## Abstract

Primary goals of this thesis were to: 1) examine the *in vivo* digestion of macronutrients from conventional or alternative feed ingredients used in practical diets of juvenile gadoids (Atlantic cod and haddock), 2) document growth potential of fish at the juvenile grower phase given varying levels of dietary protein and energy and 3) assess the potential of *in vitro* pH-Stat methods for rapid screening protein quality of feed ingredients, specifically for gadoids. All primary research questions were linked to and built upon one another with the goal of gaining a better understanding of protein and energy utilization of juvenile grower phase gadoids. Studies showed that cod and haddock have a high capacity to utilize a wide range of dietary feed ingredients, such as fish meals, zooplankton meal, soybean products (meal, concentrate and isolate) and wheat gluten meal. New dietary formulations for gadoids may also utilize pulse meals, corn gluten meal, canola protein concentrate and crab meal. Digestibility data in this thesis is currently the only research that examined both *in vivo* and *in vitro* macronutrient digestibility of a large number and wide range of individual ingredients, specifically for gadoids. This is essential to gain new knowledge on protein and energy utilization as well as for least-cost ration formulations and effective substitution of ingredients into new formulations. Data has demonstrated a dietary digestible protein/digestible energy (DP/DE) ratio of 30 g DP/MJ DE is required for gadoids during the juvenile phase (<100 g) to ensure maximum somatic tissue growth, high digestibility, maximum nitrogen and energy retention efficiency and minimal excessive liver growth. Preliminary nutrient requirement studies together with an applied nutritional approach has identified that feeds for juveniles farmed in the Western North Atlantic should contain 50-55% crude protein, <12% fat and <17% carbohydrate. Data in this thesis is currently the first aimed at development and application of an *in vitro* closed-system pH-Stat assay for rapid screening protein quality of test ingredients that is 'species-specific' to gadoids. It is demonstrated that *in vitro* results generally reflected results obtained through conventional *in vivo* protein digestibility methods. Studies resulted in the first generation of a 'gadoid-specific' proteolytic enzyme extraction method and *in vitro* closed-system pH-Stat assay which may be useful to investigate protein digestion, absorption and metabolism of gadoids and further development of their feeds.





# Contents

<b>Chapter 1</b>	General introduction	13
<b>Chapter 2</b>	Apparent digestibility of common feed ingredients by juvenile haddock, <i>Melanogrammus aeglefinus</i> L.	43
<b>Chapter 3</b>	Apparent protein and energy digestibility of common and alternative feed ingredients by Atlantic cod, <i>Gadus morhua</i> (Linnaeus, 1758).	59
<b>Chapter 4</b>	Effects of dietary protein and lipid levels and DP/DE ratio on growth, feed utilization and hepatosomatic index of juvenile haddock, <i>Melanogrammus aeglefinus</i> L.	87
<b>Chapter 5</b>	<i>In vitro</i> pH-Stat protein hydrolysis of feed ingredients for Atlantic cod, <i>Gadus morhua</i> . 1. Development of the method.	107
<b>Chapter 6</b>	<i>In vitro</i> pH-Stat protein hydrolysis of feed ingredients for Atlantic cod, <i>Gadus morhua</i> . 2. <i>In vitro</i> protein digestibility of common and alternative feed ingredients.	133
<b>Chapter 7</b>	General discussion	159
<b>References</b>		179
<b>Appendices</b>	Summary, Samenvatting List of Publications, CV Sean Tibbetts Acknowledgements Colofon	204

## List of abbreviations

AD	Apparent digestibility
ADC	Apparent digestibility coefficient
ALA	$\alpha$ -linolenic acid
ANOVA	Analysis of variance
C	Chymotrypsin
CAD	Canadian dollars
CP	Crude protein
CPSP	Concentre proteique soluble de poisson (soluble fish protein concentrate)
DE	Digestible energy
DE <sub>m</sub>	Digestible energy for maintenance
DHA	Docosahexaenoic acid
DFO	Department of Fisheries and Oceans Canada
DH	Degree of hydrolysis
DM	Dry matter
DMSO	Dimethyl sulfoxide
DP	Digestible protein
DPH	Day post-hatch
EPA	Eicosapentaenoic acid
FAO	Food and Agriculture Organization
FCR	Feed conversion ratio
FI	Feed intake
GE	Gross energy
GIM	Gastrointestinal model
GH	Growth hormone
<i>h</i>	Hydrolysis equivalent
HCl	Hydrochloric acid
Hct	Hematocrit
HSI	Hepatosomatic index
IMB	Institute for Marine Biosciences
IGF-1	Insulin-like growth factor
IU	International unit
<i>k</i>	Condition factor
KCl	Potassium chloride
kJ	Kilojoule
L	Lipid
<i>L</i> -BAPNA	<i>N</i> <sub>α</sub> -benzoyl- <i>L</i> -arginine 4-nitroanilide hydrochloride
M	Molarity
MJ	Megajoule
MW	Mean weight
N	Normality
NaCl	Sodium chloride
NPN	Non-protein nitrogen
NRC	National Research Council (USA)
NRCC	National Research Council (Canada)
OD	Optical density
P	Protein
PD	Protein digestibility
PER	Protein efficiency ratio
pKa	Buffering capacity

ppt	Parts per thousand
PSI	Pylorosomatic index
SBTI	Soybean trypsin inhibitor
[S]	Substrate concentration
SE	Standard error
S/E	Substrate to enzyme ratio
SGR	Specific growth rate
Suc-AAPF-pNA	<i>N</i> -succinyl-alanine-alanine-proline-phenylalanine- <i>p</i> -nitroanilide
T	Trypsin
TAG	Triacylglycerol
TMS	Tricaine methanesulfonate
U	Unit
UN	United Nations
USD	American dollars
VLDL	Very low density lipoprotein
WIAS	Wageningen Institute of Animal Sciences



# Chapter 1

## General Introduction

## Aquaculture in the global seafood supply

Aquaculture has become the world's fastest growing food production system over the past two decades (FAO 2009a; Subasinghe *et al.* 2009). After the remarkable increase in capture of both wild marine and inland fish during the 1950s and 1960s, global fisheries production has leveled off since the 1970s. It is estimated that 75% of the major marine fish stocks are either depleted, overexploited or being fished at their biological limit. Moreover, rapid population growth, along with increases in the average amount of fish consumed in developing countries, has led to rapid increases in global fish demand. It is widely recognized that expansion of aquaculture will fill this gap and relieve pressure on the already over-exploited wild-capture fisheries (Powell 2003; Pickova and Mørkøre 2007). Since the traditional wild-capture fisheries can only provide a maximum of 100 mmt annually (Watanabe 2002, FAO 2009a); the world would face a global seafood shortage of 50–80 mmt by the year 2030, if it were not for aquaculture (Figure 1).

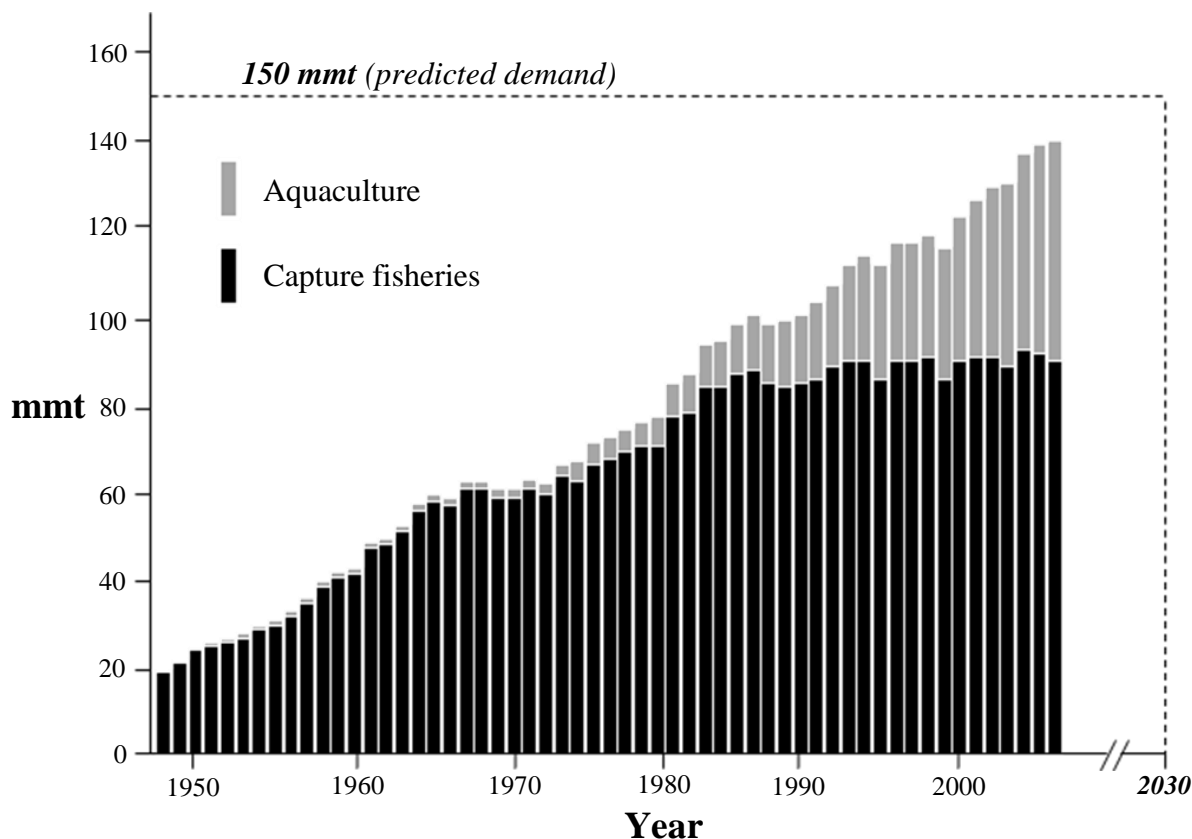

**Figure 1** Global seafood production (1950-2006) and predicted demand (FAO 2009a)

It is predicted that aquaculture will provide the most reliable supply of high quality protein for the world's rapidly expanding population in the coming years (FAO 2009b) and is, for the first time, set to contribute half of the fish consumed by the human population worldwide (FAO 2009a).

Fish and seafood provide the global population with about 6% of its total protein intake and about 16% of its total animal protein intake. At an annual growth rate of more than 9%, aquaculture's contribution to seafood supplies have grown from less than 4% in 1970 to over 32% in 2006 with an economic value of nearly \$80 billion (USD). In Canada, total aquaculture production has risen from <40,000 tonnes to >140,000 tonnes in less than 20 years (1990-2008) contributing about \$2 billion (CAD) into the Canadian economy from direct and indirect sales (DFO 2010; Grydeland 2008) and provided 14,500 full-time equivalent jobs, many of which are located in rural, previously economically-depressed regions (DFO 2010).

Protein sources derived from the ocean and aquaculture are increasingly replacing traditional food sources such as red meats and other saturated fat-rich meats. Most fishery products provide high quality dietary protein with a nearly ideal balance of essential amino acids and typically contain lower levels of unhealthy saturated fats associated with many terrestrial proteins (Santerre 2010). They are also rich in essential minerals (e.g. Ca, Cu, I, Fe, Zn, and Se) and vitamins (e.g. fat-soluble vitamins A, E and D and several water-soluble B vitamins) (Lall and Parazo 1995). There is also new evidence that marine fish products may influence insulin metabolism (Lavigne *et al.* 2001; Ruzzin *et al.* 2007), modulate type-2 diabetes and protect pancreatic and skeletal cells (Zhu *et al.* 2010) in humans. Marine fish are also a rich source of omega-3 long-chain polyunsaturated fatty acids (PUFA), eicosapentaenoic acid (EPA) and docosahexaenoic acid (DHA) (Sargent 1997; Sargent and Tacon 1999) which are known to improve cardiac, vascular and brain functions, boost the immune response, support retinal development in the fetus and nursing infant and may also help increase life span by slowing the rate of telomere shortening (Ruxton *et al.* 2007; Farzaneh-Far *et al.* 2010; Farrell *et al.* 2010). It is not surprising that the global demand for seafood products has doubled in less than 50 years (Brown *et al.* 1998) and annual *per capita* consumption is

expected to reach >20 kg by the year 2030 (FAO 2002; Watanabe 2002; Johnson 2008) representing a global demand of 150 million tonnes (mmt).

## **The wild-capture gadoid fishery**

From the earliest days of human exploration and population expansion into North America, the fish known collectively as ‘gadoids’ have been the driving force behind the development of the New World (Kurlansky 1997; Fagen 2006; Rose 2007). In the Western North Atlantic Ocean, Atlantic cod and haddock are considered the most prized of all gadoids and are the most valuable of all marine food fish (Scott and Scott 1988). Many North American economies have been dominated by their fisheries dating back to the arrival of John Cabot in 1497. Historical catch rates in North Atlantic waters are likely higher than in any other fishery the world has ever known (Rose 2007). The famous English biologist Thomas H. Huxley (1825-1895) once declared their stocks to be “*inexhaustible*” (Huxley 1884) and this was believed for many generations. Of course, the gadoid fishery was not inexhaustible and eventually, through a combination of mismanagement, greed and overexploitation this lucrative industry was essentially shut down in 1992 when a moratorium was placed on all fishing activities. Recently, it was reported that the North Atlantic spawning stock biomass of >250,000 tonnes in the early 1970s had declined by almost 85% to only 39,000 tonnes by 2002 - about half of what scientists judge the stock as a high risk for collapse (Horwood *et al.* 2006) and the stocks continue to decline to levels far below the maximum sustainable yield (Hutchings *et al.* 2010). Yet, to this day, these gadoids remain in high demand on the North American seafood market.

## **Gadoid aquaculture**

### ***Development***

The market demand for Atlantic cod and haddock remains high in spite of the collapse of the gadoid fishery in the 1990s. As such, there has been a renewed interest in fish farming as a means to meet the demand for this valued seafood and to ease the strain on wild populations that would have otherwise been fished into extinction. Since the mid-1980s, development of gadoid farming has been a focus of governments and industry



in countries that border the North Atlantic. Over the past 3 decades, advances have been made in hatchery technologies, larval development, health management and development of feeds; but commercial progress has been very slow due mainly to insufficient juvenile production. In addition, the industry has been plagued with other problems including a poor understanding of larval, juvenile and broodstock nutrition, fish health and disease problems, early sexual maturation, low survival of larvae, skeletal deformities, limited research and development and capital investment and high operational and feed costs (Aiken 2003, Bricknell *et al.* 2006; Kjesbu *et al.* 2006; Rosenlund and Skretting 2006; Treasurer 2008). Many of these problems are now being addressed, year-round annual production is rapidly increasing and predictive growth models for various geographical locations are being developed (Chambers and Howell 2006; Treasurer *et al.* 2006; Björnsson *et al.* 2007) for cod and haddock. Estimated global production of farmed gadoids in the near future is as high as 200,000 tonnes (Kjesbu *et al.* 2006; Rosenlund and Skretting 2006). However, due to high production costs and the recent global economic crisis, current commercial aquaculture production has been limited to Western Europe (>90% Norway and Iceland) (Hagen and Solberg 2010). In the past few years (2002-2008), these two countries have established 536 cod farms (13 in Iceland and 523 in Norway) and 14 haddock farms (all in Norway) and have increased the number of juveniles stocked into sea pens from 1.5 million to 21 million (Paisley *et al.* 2010). This has resulted in increased production from less than 250 tonnes (approximate value of \$1 million USD) to more than 16,500 tonnes (approximate value of \$55 million USD) (Norwegian Directorate of Fisheries 2010). Although other North Atlantic countries have fallen far behind Norway and Iceland, industry experts still predict farmed gadoid production to surpass that of farmed salmonids within 2 decades (Standal and Utne 2007).

### ***Culture of gadoids in Eastern Canada***

Culture protocols developed over the past decade at the NRCC Institute for Marine Biosciences' Marine Research Station (Ketch Harbour, Nova Scotia), Aquarium and Marine Centre (Shippagan, New Brunswick), the Fisheries and Oceans Canada – Biological Station (St. Andrews, New Brunswick) and Memorial University - Ocean

Sciences Centre (Logy Bay, Newfoundland and Labrador) have been successfully used to rear both Atlantic cod and haddock from egg to juvenile and provided experimental fish for the studies presented in this thesis. Fertilized eggs (1.3-1.7 mm diameter) from naturally-spawning, mixed-sex wild broodstock held at 6-10°C are collected from the top 40 cm surface of large (e.g. 45,000 L) broodstock tanks from late-December to mid-January and are immediately surface-disinfected with 400 ppm of gluteraldehyde. This spawning period is 3 months earlier than would occur in the wild and has been achieved through photoperiod manipulation. Incubation occurs in either total darkness or very low light levels at 5-8°C for 11-20 days in upwelling conical tanks (e.g. 100-250 L). Hatched yolk-sac larvae are transferred to 3000-3500 L weaning tanks and are immediately offered live rotifers to supplement their yolk-sac reserves, which become depleted after only 5-9 days. Over several weeks (typically 10-12), the water temperature is gradually increased to 10-12°C (1°C every couple days) to enhance feeding behaviour. The tanks are equipped with mild aeration, low water velocity, protein skimmers and are exposed to continuous 24 h moderate light intensity. Our lab has performed larval weaning in both dark bottom and bright bottom tanks and both with and without 'green water'. Newly stocked larvae are fed rotifers (cultured on marine algae and baker's yeast) up to 7-10 day post-hatch (DPH) and then rotifers enriched with commercial high-DHA products until about 25-30 DPH. Highly DHA-enriched *Artemia* nauplii are then fed until 37-52 DPH after which weaning is begun (12-15 mm fork length), which typically lasts for about 1-2 weeks. During this weaning period, the proportion of live *Artemia* nauplii is gradually reduced as various dry formulated microparticulate diets are introduced until feed particles can be observed in the stomachs of metamorphosed larvae. We have used commercial weaning diets from Italy, Norway, Japan and Canada and also several experimental feeds produced in our laboratory and have seen specific growth rates in excess of 15%/day and >88% larval survival (unpublished data). Although advances have been made and high larval survival (>80%) can be achieved in laboratory studies, the weaning period still remains one of the predominant bottlenecks for producing high numbers of juveniles for commercial culture. Once weaned, the fish are cultured in the same or similar tanks or deep raceways and fed commercially manufactured extruded gadoids feeds based on recommended formulations (typically 50-60% crude protein and

12-16% lipid) until they reach 3-5 grams (3-4 months). The juveniles are then transferred to modified salmon sea cages for on-growing to market weight of 2-3 kg in about 36 months (Frantsi *et al.* 2002; Brown *et al.* 2003; Lanteigne and Leadbeater 2003).

## **Gadoid nutrition**

The dietary nutrients required by fish are generally the same as those of terrestrial animals in that they all require sources of protein and amino acids, lipid and essential fatty acids, vitamins, minerals and energy for growth, reproduction and other normal physiological functions (Lall and Tibbetts 2009). The major differences between fish and terrestrial animals include: (a) higher protein levels relative to non-protein macronutrients are required in the diet of fish (b) dietary energy requirements are lower for fish (e.g. aquatic mode of life, poikilothermy and ammoniotelism), resulting in higher dietary protein/energy ratios, (c) fish require some lipids that terrestrial animals typically do not, such as omega-3 series PUFA for several marine and salmonid species and sterols for crustaceans, (d) most fish (especially cold-water species) have a limited capacity to utilize carbohydrates, (e) fish have the ability to absorb soluble minerals from the water which minimizes the dietary need for certain elements and (f) fish have limited ability to synthesize ascorbic acid and must depend upon dietary sources (NRC 2011). Information on dietary nutrient requirements and bioavailability of farmed gadoids are limited. Initial studies show relatively high protein requirements of 45-60% for juveniles (Lall and Nanton 2002; Lall *et al.* 2003; Rosenlund *et al.* 2004; Árnason *et al.* 2010), a phosphorous requirement of 0.96% (Roy and Lall 2003) and a low tolerance (12-16% maximum) for dietary lipid (Lie *et al.* 1988; Nanton *et al.* 2001).

### ***Dietary protein***

Proteins represent the largest components of fish at 65-75% of the total dry weight (Wilson 2002). These proteins are the primary constituents of structural and protective tissues (e.g. bones, ligaments, scales and skin), soft tissues (e.g. organs and muscles) and body fluids (Lall and Anderson 2005). As such, for most marine fish like gadoids, protein comprises the largest portion of the diet and is required for growth,

tissue repair and reproduction and as a source of dietary energy (Wilson 2002). An overview of the fate of ingested dietary protein in fish is presented in Figure 2.

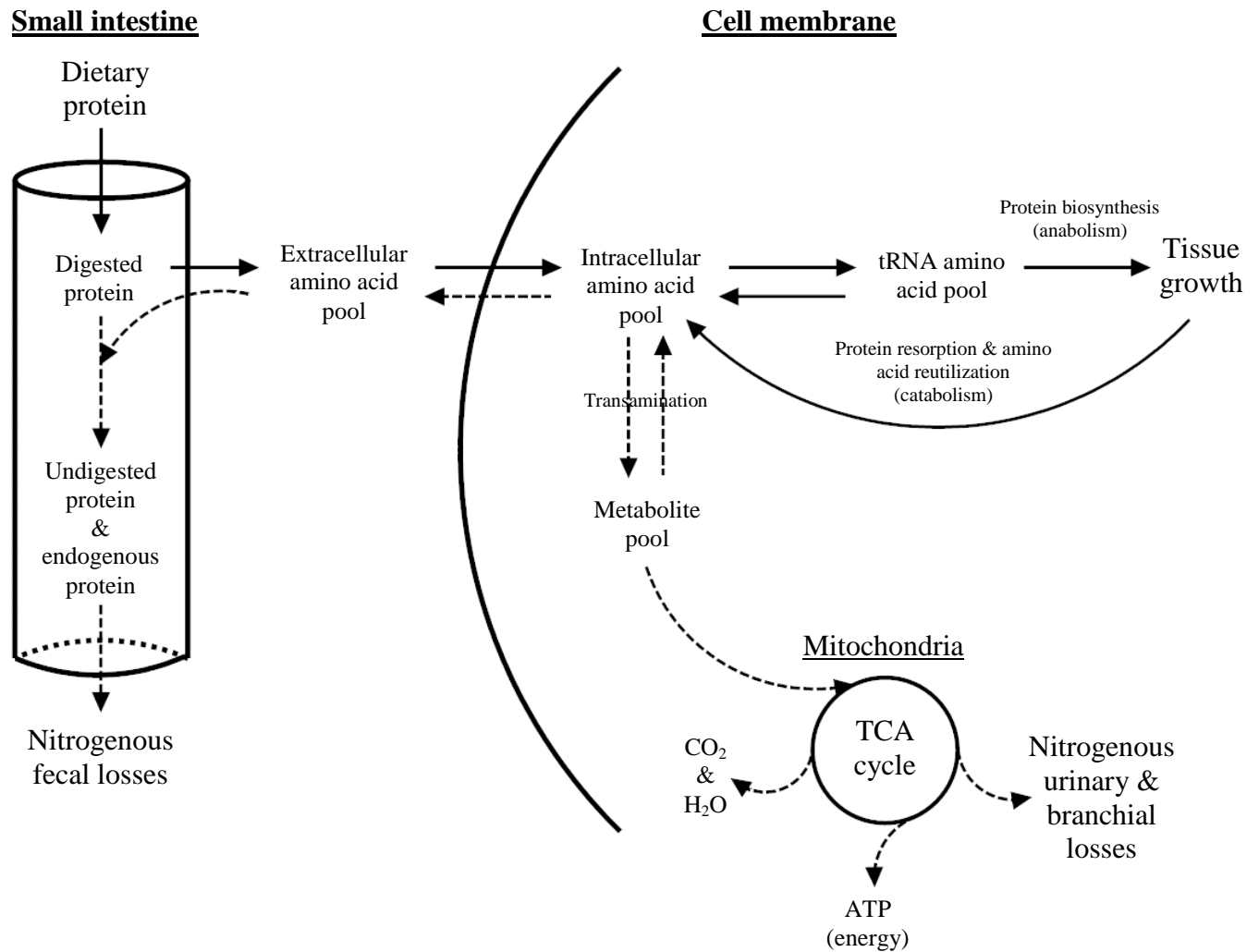

**Figure 2** Fate of ingested dietary protein in fish (adapted from Rathmacher 2000; Sveier 2004)

Because most coldwater, carnivorous marine fish directly swallow food particles with little mastication in the mouth and oesophagus (Gerking 1994; Houlihan *et al.* 2001), protein digestion does not begin until it reaches the acidic (< pH 4) stomach. In the stomach, ingested food particles encounter mucous secreted from the non-parietal cells that hydrate it and gastric fluids (e.g. HCl, KCl, NaCl) secreted by the parietal oxynticopeptic cells that initiate protein digestion under endocrine and neuronal control

(Wendelaar-Bonga 1993). The acidic nature of the gastric fluids help denature (open) protein strands exposing peptide bonds to enzymatic attack and also activate pepsinogen (a zymogen produced by the stomach's chief cells) into its active form, pepsin (Smith 1989). Pepsin then actively cleaves ingested proteins into smaller polypeptides prior to transit out of the stomach and into the alkaline pyloric caeca at which time the digesta pH is raised (~ pH 7) by mixing with bicarbonate excreted by the acinar cells (Rust 2002). Once in the pyloric caeca, proteins and polypeptides are further degraded into smaller peptides and free amino acids under the action of alkaline proteases and peptidases (e.g. trypsin, chymotrypsin, elastase, collagenase, aminopeptidases, carboxypeptidases, etc.) via extracellular, membrane-linked and intercellular digestion (Kuz'mina and Gelman 1997). It is from this point forward into the small intestine that ingested and digested proteins are absorbed through the brush-border of the enterocytes (intestinal cells) via pinocytosis (proteins and peptides), active H<sup>+</sup> and/or Na<sup>+</sup>-assisted transport (peptides and free amino acids) and passive diffusion (free amino acids) for delivery into the blood stream and transport to the liver (Storelli and Verri 1993).

Although the 'digestive system' prepares ingested protein for absorption, it is the role of the 'endocrine system' to regulate their metabolism in fish and mammals (Houlihan *et al.* 1995; Garlick *et al.* 1998). As shown in Figure 2 above, these newly absorbed protein products (now in the intracellular pool) can either be used for protein biosynthesis (e.g. growth, tissue repair, reproduction) or broken down (deamination) for use as dietary energy. Since dietary protein is the most expensive component of the diet, exceeding the levels needed to satisfy a particular species' dietary requirements results in elevated nitrogenous waste (e.g. ammonia from the gills and urea in urine) excretion into the surrounding waters, which is both economically and environmentally undesirable (Lall and Tibbetts 2009). The hormonal regulation of these pathways in fish is not fully understood but is likely through the action of glucose-uptake hormones (e.g. insulin, insulin-like growth factor (IGF-1) and growth hormone (GH)) that all play a role in promoting protein synthesis (Houlihan *et al.* 1995; Mommsen and Moon 2001) whereas glucose-liberation hormones (e.g. catecholamines, glucagon, glucagon-like peptides and glucocorticoids) promote protein catabolism for energy purposes (Maynard *et al.* 1975; Dabrowski and Guderley 2002). With regard to protein synthesis, insulin, IGF-1 and

GH appear to function by increasing amino acid uptake, increasing ribosomal availability, increasing the numbers and types of messenger RNA (*mRNA*) and increasing the rate of protein transcription (Manchester 1977; Dabrowski and Guderley 2002). As for protein catabolism for energy purposes, catecholamines, glucagon, glucagon-like peptides and glucocorticoids function by increasing hepatic enzyme activities in the short-term and altering their gene expression over the longer term resulting in amino acid conversion to glucose (gluconeogenesis) in the liver (Mommsen and Plisetskaya 1991; Duguay and Mommsen 1994; Plisetskaya and Mommsen 1996).

The primary goal of optimum diet formulation is to ensure that the highest possible proportion of ingested protein ends up as tissue growth (shown as solid lines in Figure 2) while minimizing the proportion that ends up being deaminated and catabolized for energy (shown as dotted lines in Figure 2). The relative proportions of energy-yielding nutrients in the diet (protein, lipid and carbohydrate) result in varying post-prandial influxes of amino acids, fatty acids and sugars (Carter *et al.* 2001) which, in some species, have a large effect on whether ingested proteins becomes new tissue growth or get used as an energy source in the liver and ultimately excreted as nitrogenous waste (e.g. branchial and urinary excretions). This will be discussed in more detail in the following sections on dietary energy and DP/DE ratio.

The natural diet of wild gadoids off the coast of Eastern Canada is not only piscivorous (fish-consuming) but also high in crustaceans and echinoderms, so these species have an inherent capacity to utilize chitin- and ash-rich benthic foods, unlike that of more pelagic species like salmonids (Lall and Nanton 2002; Morris and Green 2002). The most commonly used sources of dietary protein for farmed gadoid are by-product meals made from fish, krill, crustacean, poultry, corn and soybean. Dietary protein requirements have been established by many authors over the past century and compiled by Wilson (2002) for several fish including cold-water species farmed in Canada including: Atlantic halibut, Atlantic salmon, Chinook salmon, coho salmon, sockeye salmon, rainbow trout, brown trout, striped bass and plaice and are in the range of 40-55% of the diet. A more detailed review taking into account various growth phases (e.g. <20 g to >1.5 kg) has been compiled for Atlantic salmon, Pacific salmon and rainbow trout and indicate that dietary protein requirements general decrease from ~50% to ~35%

over this growth period (NRC 2011). Initial studies with farmed gadoids show protein requirements of 45-60% of the diet for juveniles (Lall and Nanton 2002; Lall *et al.* 2003; Rosenlund *et al.* 2004; Árnason *et al.* 2010). The protein requirement of gadoids appears higher than other species due to poorer protein retention efficiency (Lie *et al.* 1988) and this may be related to a lower tolerance for non-protein energy and less opportunity for protein sparing.

Protein, a polymer of amino acids joined together by peptide bonds, when hydrolyzed in the gastrointestinal tract of an animal supply amino acids and peptides for tissue synthesis and repair and are also catabolized to provide energy. Amino acid nutrition and metabolism in fish has been extensively reviewed (Wilson 2002; Lall and Anderson 2005; Kaushik and Seiliez 2010). From a nutritional standpoint, the 20 known amino acids are considered as being either non-essential (dispensable) or essential (indispensable). Non-essential amino acids are those that can be synthesized by the animal in quantities sufficient enough to support maximum growth. Of the non-essential (dispensable) amino acids, two are particularly unique for their ability to partially replace two of the essential (indispensable) amino acids; tyrosine and cystine can spare ~50% of a fishes' dietary requirement for phenylalanine and methionine, respectively. Essential amino acids (EAAs) are those that the animal cannot synthesize in sufficient quantities to support maximum growth and, therefore, must be provided in the diet. To better explain this, certain amino acids appear to be essential because the animal lacks the biochemical mechanisms required to synthesize the chemical configurations of the carbon chain skeletons of these amino acids (Jobling 1994). Most monogastric animals, including fish, require the same 10 EAAs: arginine, histidine, isoleucine, leucine, lysine, methionine, phenylalanine, threonine, tryptophan and valine. As stated, fish and other animals do not truly have a requirement for protein; rather it is a requirement for the EAAs contained within that protein. When a protein requirement is stated for a certain organism, it should always be assumed that it is of high protein quality and adequately balanced in terms of its amino acids. The ration which has the highest protein quality is typically the one which supplies all of the EAAs needed in proportions most similar to those in which they exist in the protein to be formed, plus an appropriate non-specific source of nitrogen to form the non-EAAs (Maynard *et al.* 1975). Partial or complete EAA requirements of fish

established using chemically defined, purified and natural ingredient diets using dose-response methodologies have been reviewed by NRC (2011). Cold-water species farmed in Canada examined to date include: Atlantic salmon, Chinook salmon, chum salmon, coho salmon, sockeye salmon, rainbow trout, lake trout and Arctic char. Quantitative EAA requirements (as a % of dietary protein) of these species are in the following range: arginine (3.5-6.0%), histidine (1.0-1.8%), isoleucine (1.5-2.8%), leucine (2.7-9.2%), lysine (3.0-8.4%), methionine (0.7-1.9%), phenylalanine (2.0-4.4%), threonine (2.6-3.0%), tryptophan (0.3-0.9%) and valine (1.7-3.4%). Dietary EAA requirements for gadoids have not yet been studied and will not be addressed in this thesis; however, for experimental diet formulation, the EAA requirements of Atlantic salmon and rainbow trout were followed.

### ***Dietary energy***

Energy is not a nutrient but it is released in the body from food during metabolic oxidation of carbohydrates, fats and amino acids (NRC 2011). Because it is not a physical organic or inorganic compound it cannot be quantified in the same manner as the macronutrients. Energy is an abstraction that can only be measured in its transformation from one form to another (NRC 1981). The most common method for determining the gross energy content of fish feeds and feed ingredients is bomb calorimetry. This method involves completely oxidizing the compound to carbon dioxide, water and other gases in a bomb calorimeter and measuring the amount of heat that is released (e.g. heat of combustion). Common units of measure for energy content of feeds is the calorie (equal to 4.184 joules) and is defined as the amount of heat required to raise the temperature of 1 gram of water by 1°C measured from 14.5°C to 15.5°C (Lovell 1989). Since all organic compounds in fish feeds release heat upon combustion, thus are potential sources of dietary energy, the energy content of a diet will depend on its chemical composition, with the mean values of heat of combustion of protein, lipid and carbohydrate being 5.64, 9.44 and 4.11 kcal/g, respectively (NRC 2011).

Fish consume food to satisfy their energy requirement (NRC 2011). This implies that the caloric density of a diet plays a large role in regulating feed intake, which directly affects the intake of other essential nutrients. Bioenergetics is the study of the balance



between energy intake in the form of food and energy partitioning or utilization by animals for life-sustaining processes such as maintenance, activity and tissue synthesis. The partitioning of dietary or intake energy (IE) of feeds to that component retained (RE) for productive purposes in fish was first proposed by NRC (1981) and is depicted in Figure 3.

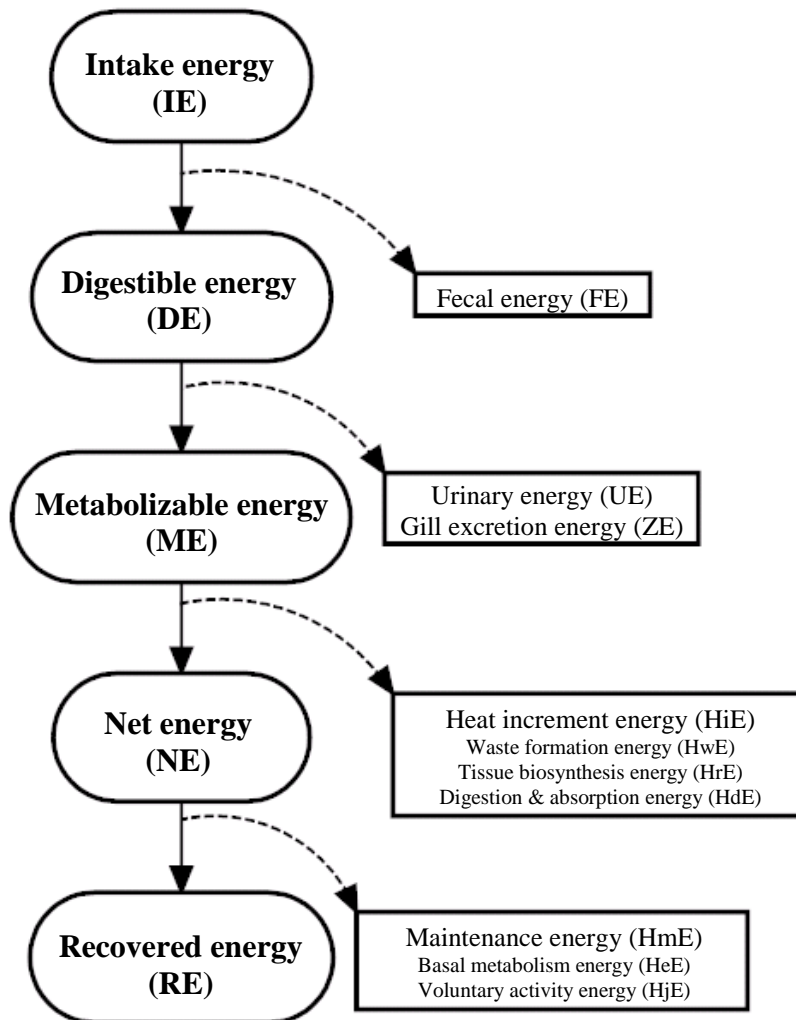

**Figure 3** Partitioning of dietary energy in food consumed by fish (adapted from NRC 1981, 2011; Bureau *et al.* 2002)

Gross energy or intake energy (IE) is the total amount of energy contained within the diet. As with all dietary nutrients, total or gross amounts are of little value to the

nutritionist when formulating diets due to the fact that animals do not utilize 100% of the nutrients contained within a ration. Invariably, there will always be inefficiencies resulting in nutrient losses in the form of faeces, urine and gill excretion. Ideally, for fish production, it is necessary to minimize these losses in order to obtain maximum returns as marketable products. The first task in evaluating the potential of any feedstuff for inclusion in the diet is the measurement of its digestibility (Cho *et al.* 1982). This can be defined as the extent to which dietary nutrients are broken down and absorbed from the digestive tract. In fish, it is difficult to separate faeces from the water, and to avoid contamination of the faeces with the uneaten food. This problem has required several different approaches to those used in the measurement of digestibility for terrestrial farmed animals and birds. Whereas total collection of faecal material from animals and birds can be achieved with little difficulty, it is not feasible with fish. A method has been developed by Post *et al.* (1965) and Smith (1971) however, this direct method requires very specialized equipment, the necessity of force feeding and the physiological stress caused by confinement. To overcome these shortcomings, indirect methods for quantifying faecal output have been developed. These methods utilize inert markers such as chromium oxide, acid insoluble ash, yttrium oxide and various others and changes in the ratio of nutrient to marker between diet and faeces should reflect the extent to which the nutrients in the diet have been digested, on the assumption that the marker is not absorbed from the feed and is fully excreted in the faeces. Some common methods of faecal collection in fish include manually stripping, anal suction, dissection, siphoning, filtration and sedimentation (Cho *et al.* 1982). All methods have limitations and may lead to either under or over estimations of digestibility. Once digestibility of a feedstuff or diet has been measured, digestible energy (DE) can be calculated from the IE value. DE is the IE content of the diet minus the energy loss in the faeces ( $DE = IE - FE$ ). Faecal energy (FE) losses for farmed fish usually account for 5-30% of IE depending upon feed composition, processing and feeding rate (Jobling 1994). The DE content of a well-digested food would approach its IE content. The DE content of numerous commonly used practical fish feed ingredients are listed in Halver and Hardy (2002) for rainbow trout and channel catfish and range from 2-13 MJ/kg for high-fibre and high-carbohydrate products like alfalfa, canola, wheat, cotton-seed, whey and un-processed

corn meals, 13-21 MJ/kg for processed corn and wheat, yeast, oilseed and animal, crustacean and fish by-product meals to over 33 MJ/kg for vegetable and fish oils and animal fats. The DE content (MJ/kg) of some purified ingredients commonly used in experimental fish feeds were compiled by NRC (2011) and include casein (17), corn starch (17), gelatin (12), glucose monohydrate (14), lactose (15) and sucrose (16).

Digestion of fats and carbohydrates yield fatty acids and simple sugars and, in turn, yield carbon dioxide, water and heat. However, digestion of proteins yield amino acids which, in turn, yield ammonia (85-90%) and, to a lesser extent, urea (10-15%) as well as carbon dioxide, water and heat (Kaushik and Cowey 1991). These products must be excreted via the gills (ZE) or by the kidney as urine (UE). Quantifying ZE and UE can be difficult as measurements of these losses require respirometers where fish must be held under stressful conditions. If these losses can be quantified, metabolizable energy (ME) value ( $ME = DE - (ZE + UE)$ ) can be determined. ME content of the diet is important as it accounts for these types of dietary energy losses and more closely reflects the food energy in feeds that the fish can use for productive purposes.

After digestion and absorption of nutrients from a feedstuff, they are metabolized for various biochemical functions including transfer of chemical energy from nutrients to energy-rich molecules such as ATP, transformation of nutrients into biologically important substances, ATP hydrolysis to perform physical or chemical work, maintenance of cellular homeostasis, biosynthesis and/or turnover of tissues and physical activity. All these processes require energy and result in the liberation or release of heat by the animal. The energy in the form of heat that is lost at this point is termed the heat increment ( $H_iE$ ) and can be subdivided into three components: waste formation energy ( $H_wE$ ), tissue biosynthesis energy ( $H_rE$ ) and digestion and absorption energy ( $H_dE$ ). Once these losses are quantified, they can be used to adjust the ME value to form the net energy (NE) value ( $NE = ME - (H_wE + H_rE + H_dE)$ ). NE content of the diet is a better estimate than ME as it accounts for these energy losses but is more difficult to obtain on a routine basis.

Energy is also required by the animal for those functions of the body that are essential for sustaining life regardless of whether or not the animal is consuming food. The heat liberated at this point is termed maintenance energy ( $H_mE$ ) losses and are

comprised of two components: basal metabolism ( $H_cE$ ) and voluntary or resting activity ( $H_jE$ ) such as minor bodily movements. If these losses can be quantified, they can be used to correct the NE value to form the recovered energy (RE) value ( $RE = NE - (H_cE + H_jE)$ ). RE is the final step in the partitioning of dietary energy and is the portion of the IE that is used by the fish for productive fish growth. It is the RE value that the fish farmer and nutritionist should attempt to maximize by attempting to minimize the amount of energy losses in the forms of faeces, urine, gill excretion and heat. RE content is the best estimate of the true value of the diet because it accounts for all energy that is lost in other forms than growth. RE content cannot be economically or routinely measured in fish so the DE (and to a lesser extent the ME) is commonly used for practical fish feed formulations since the faecal losses represent the largest fraction of losses in the IE.

### ***Digestible protein/digestible energy (DP/DE) ratio***

The most abundant and expensive component of marine fish diets is protein, so maximizing its transformation into a marketable seafood product is always the ultimate goal even when discussing other dietary components, such as calories from fats and carbohydrates. In coldwater fish, ingested protein and amino acids can only be efficiently converted into somatic tissue growth when there is a sufficient dietary non-protein energy supply (Bureau *et al.* 2002). In many fish, increasing the levels of digestible energy from non-protein energy sources can spare dietary protein for protein biosynthesis, with lipids being the most effective due to the relatively low utilization of glucose by coldwater species (Rychly 1980; Kaushik and de Oliva-Teles 1985; Médale *et al.* 1991). To varying degrees, these non-protein energy sources have the ability to supply fatty acids (from ingested dietary lipids) and/or glucose (from ingested dietary carbohydrates) that can replace amino acids from entry into the tricarboxylic acid (TCA) cycle (also referred to as the Krebs or citric acid cycle) for energy production purposes, thereby ‘sparing’ them for protein synthesis. This is possible because the primary metabolites that feed into the TCA cycle are acetyl CoA, acetoacetate, pyruvate, succinyl CoA, fumarate, oxaloacetate and glutamate, all of which can be produced either from fatty acids, glucose or amino acids (Maynard *et al.* 1975). This scenario promotes the desired pathway shown in Figure 2 (solid lines). Alternatively, when insufficient non-

protein energy is provided in the diet, a higher proportion of digested protein (amino acids) is deaminated in the body's cells to supply energy for metabolism *a priori* to protein synthesis and the less desirable pathway (shown in dotted lines in Figure 2) is followed. This scenario not only results in less than optimal nitrogen retention efficiency and protein utilization, but also increased formation of nitrogenous waste products (e.g. mainly ammonia and urea) that must be voided into the marine environment (Kaushik and Cowey 1991). Therefore, a proper balance of protein and non-protein energy is necessary to supply calories and amino acids for rapid growth, efficient feed utilization and nitrogen retention efficiency and also to minimize water pollution (Bureau 2004). Some of the metabolic consequences of lipid replacement of protein in marine fish diets include lower ammonia excretion rates (Van Warde 1983), decreased oxygen consumption (Cho 1987), inhibition of glycolysis (e.g. reduced conversion of ingested protein into glycogen reserves) and lipogenesis (e.g. reduced conversion of ingested protein into fat reserves) (Jürs *et al.* 1985) and increased amino acid utilization for protein retention and tissue biosynthesis (Suárez *et al.* 1991). Peres and Oliva-Teles (2001) demonstrated that both ammonia excretion and oxygen consumption were inversely correlated to dietary non-protein energy levels and a decrease in the dietary DP/DE ratio spared protein for metabolism, essentially due to decreased non-fecal nitrogen and heat increment of feeding. The role of dietary protein and energy balance on fish performance and the effects on the marine environment has been extensively reviewed (Kaushik 1998). Since gadoids appear to have a low tolerance for dietary lipid (maximum 12-16% of the diet, Lie *et al.* 1988; Nanton *et al.* 2001), relative to other marine species like salmonids that are routinely fed diets containing 25-40% lipid, the potential to achieve this protein sparing effect may be rather limited in gadoid diets. However, determining the optimum DP/DE ratio is considered as one of the most important criteria to develop diets for new farmed species. Both dietary protein and lipid supply highly bioavailable forms of digestible energy (DE) to gadoids. However, the use of protein as a dietary source of energy is undesirable because of the high cost of protein relative to the cost of non-protein energy (Watanabe 2002). A proper balance of digestible protein and digestible energy is necessary to maintain high growth rates and good feed conversion efficiency (Lee and Putnam 1973), improve protein utilization and

minimize excessive accumulation of lipid and glycogen in the somatic tissues and liver and minimize undesirable nitrogenous waste output into the marine environment (Cho and Kaushik 1985, 1990). While the estimated optimum DP/DE ratio for coldwater species like rainbow trout and Atlantic salmon in the juvenile phase is 19–24 g DP/MJ DE (Cowey 1992; Einen and Roem 1997; Storebakken 2002), the DP/DE ratio for larger salmon (>2.5 kg) decreases to 16–17 g DP/MJ DE (Einen and Roem 1997). Information on protein and energy utilization by gadoids is limited and this problem is also confounded by the fact that the optimum DP/DE ratio changes with fish size, growth rate and feed intake (Lupatsch *et al.* 2001). Given the marked differences in lipid tolerance between gadoids and salmonids, the established DP/DE ratios for salmonids and other species will not be suitable for use in feeds for farmed gadoids. Initial dietary protein requirements of gadoids were estimated by feeding graded levels of dietary protein using isoenergetic (isocaloric) diets and provided a good starting point to estimate the optimum DP/DE ratio required for optimum growth of juvenile gadoids. However, growth performance, feed conversion and nutrient retention efficiency of diets formulated with varying combinations of protein and non-protein energy is still required.

### ***Protein quality***

Fish, animal and plant by-products are widely available for use as major sources of dietary protein in marine fish feeds (Hardy 2010; Hardy and Barrows 2002). These products can vary considerably in their protein quality and nutrient profile depending upon the freshness, origin, species/cultivar, season of harvest, presence of anti-nutritional factors (ANFs) and other factors associated with the raw material such as the drying process, processing temperatures, storage and transport conditions and exposure to humidity and ultraviolet light (Figure 4).

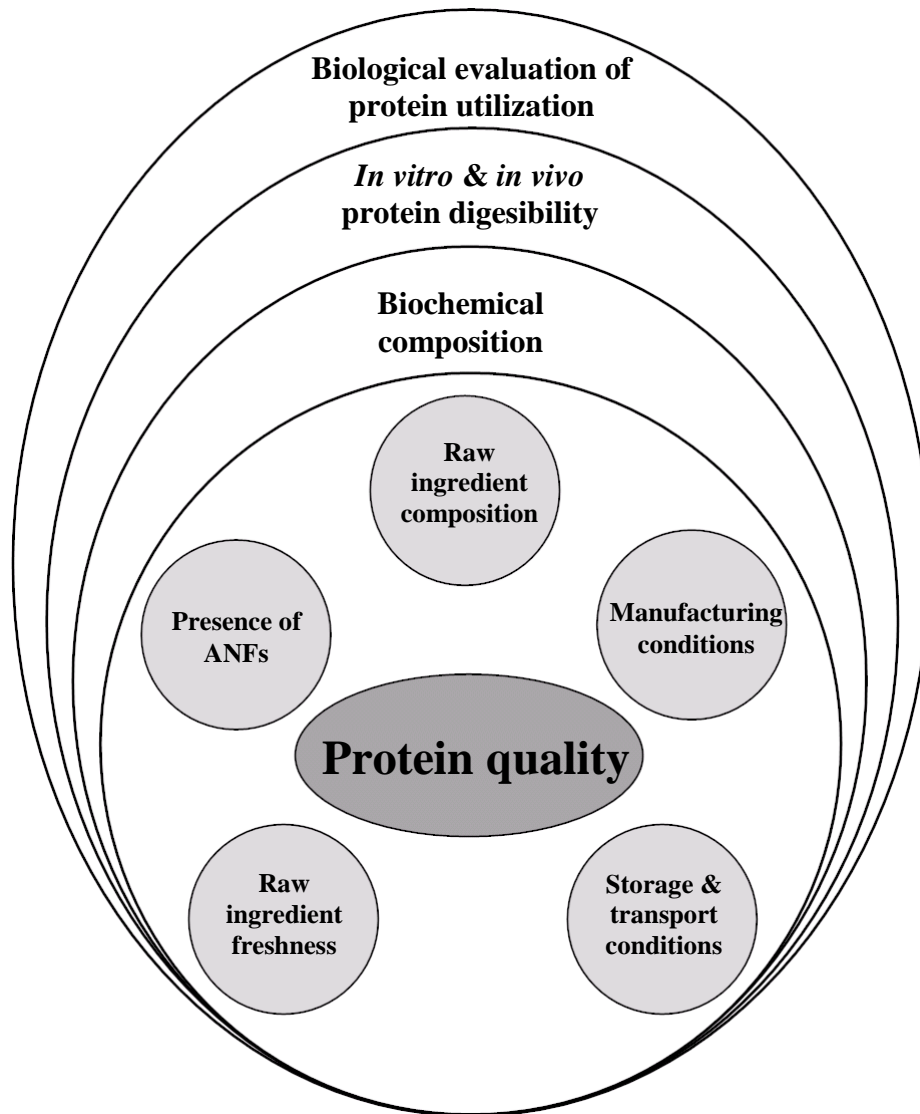

**Figure 4** Factors affecting dietary protein quality and the levels of its assessment (adapted from Bender 1982; Pike 1991)

Not only the protein ‘quantity’, but the ‘quality’ has a marked effect on animal performance, however, there is no one ‘single’ figure to describe the protein quality of feed ingredients or complete diets (Bender 1982). It must be a combination of biochemical analysis, essential amino acid (EAA) profiles (in particular the quantity and availability of the most limiting EAAs), *in vivo* and *in vitro* protein and EAA bioaccessibility and the efficiency of protein utilization measured by biological evaluation (growth and nutrient metabolism studies) with the target species. With respect

to the common and alternative feed ingredients and the complete diets used in the studies presented in this thesis, we will address several of these areas; in particular biochemical analysis, *in vivo* and *in vitro* protein hydrolysis and efficiency of protein utilization for growth. After preliminary biochemical analyses, the major criterion for determining the nutritive value of a protein source is the apparent digestibility coefficient (ADC). Conventional biological methods for measuring protein ADC involves *in vivo* fish trials that are time-consuming, require expensive facilities and use large numbers of animals. In addition, total collection of faeces from fish is typically not possible, so indirect methods must be used that involve the addition of inert markers to the diet (e.g. chromic oxide, yttrium oxide, acid-insoluble ash, etc.) and then quantification in the diet and the collected dried faecal samples, which may be costly.

Several *in vitro* protein digestibility methods have been developed over the past century. These assays involve the use of various commercial enzymes like pepsin (Sheffner *et al.* 1956), bacterial proteases (Ford and Salter 1966), papain (Buchanan 1969), trypsin (Maga *et al.* 1973), trypsin/chymotrypsin/aminopeptidase (Hsu *et al.* 1977) and trypsin/chymotrypsin/aminopeptidase/bacterial proteases (Satterlee *et al.* 1979). These methods are considered not suitable for fish assays because the enzymes are derived from homeothermic animals, plants and bacteria that are anatomically and physiologically different from poikilothermic fish. Dimes and Haard (1994) developed the first *in vitro* method that appears better-suited for use with fish. They demonstrated that digestive proteases extracted from the pyloric caeca of rainbow trout used in a pH-Stat assay correlated well ( $R^2=0.82$ ) with *in vivo* protein digestibility. The pH-Stat assay has been used in human and farm animal nutrition research to estimate the *in vitro* protein digestibility of feed/food ingredients in the past but these authors were the first to introduce the method to aquafeeds. Although the other *in vitro* protein digestion techniques discussed above have been investigated with aquatic animals, the pH-Stat method has shown the most encouraging results with finfish and shrimps (Dimes and Haard 1994; Alarcón *et al.* 2002; Lemos *et al.* 2009). The assay involves the proteolytic enzyme hydrolysis of a test protein substrate at a target pH and directly measuring the breakage of peptide bonds. When protein bonds are cleaved, free carboxyl (-COOH) residues are liberated which allows for the exchange of hydrogen ( $H^+$ ) protons (Wei *et al.*



2003). This release of positively charged hydrogen ions causes the reaction mixture to become more acidic. In order to counteract this decline of pH, the pH-Stat titration system accurately adds titrant (e.g. NaOH) to maintain the target pH, thereby eliminating the effects of changing pH on proteolytic activity and also the effects of buffering caused by the newly released amino groups (Wei and Zhimin 2006). The pH-Stat system software accurately records the total volume of titrant required to maintain the target pH until protein hydrolysis is complete or the reaction is manually stopped. This titrant volume, combined with various other data, is then used to calculate the degree of protein hydrolysis (DH), which is a direct measurement of the number of peptide bonds that have been cleaved during protein hydrolysis.

*In vitro* pH-Stat methods have been used to predict animal performance when fed various feed formulations, to assess the effects of processing of plant protein supplements, to assist in designing new feed formulations as well as to produce novel feed/food hydrolysates (Adler-Nissen *et al.* 1983; Lemos *et al.* 2009; Lemos and Nunes 2008). Significant successes have been achieved with shrimps while most investigations with finfish have encountered technological problems and poor repeatability. *In vitro* pH-Stat methods have yet to be applied commercially to aquafeeds due the lack of a standardized method, resulting in poor reproducibility within and between laboratories, unaccounted variations in batch-to-batch enzyme activities and a poor understanding of the effects of dietary history of the donor animals on enzyme profile and catalytic activity. The major limitations for *in vitro* pH-Stat assays appear to be the need for complete knowledge of the origin of enzymes and their activities because variations in species, fish size/age and phenotype give results with poor reproducibility, pH-Stat assays give inaccurate results for ingredients that have been pre-hydrolysed and the digestive tissues must be extracted from live fish, thus a well-equipped analytical lab is required to produce to enzyme fractions (Savoie 1994).

Under farmed conditions, food intake and digestion by fish are highly affected by numerous biotic and abiotic factors (e.g. culture conditions, water quality, presence of stressors, social interactions, changing feeding rhythms, nutritional and reproductive status (Lall and Tibbetts 2009) that can vary temporally and among stocks of fish. All of these factors, together with the well documented effects of fish size/age, phenotype,

dietary protein level and seasonal variations on proteolytic capacity (Bassompierre *et al.* 1998a,b; Einarsson *et al.* 1997; Førde-Skjærvik *et al.* 2006; Kofuji *et al.* 2005; Olsen and Ringø 1998) influence food digestion in fish *in vivo*, negatively affect the reproducibility of both *in vivo* and *in vitro* results and ultimately complicate the application of *in vitro* results to industrial conditions. It is widely recognized by human and animal nutritionists that it is possible to make reasonable predictions *in vitro* for research and industrial use. As such, *in vitro* pH-Stat methods can provide an attractive complement to biochemical and *in vivo* biological methods as they are relatively inexpensive, require less animals and results can be rapidly obtained (hours vs. weeks) using very small quantities of test sample. These characteristics could make *in vitro* pH-Stat methods more suitable for initial rapid screening under research and industrial conditions and certainly more acceptable from the stand-point of animal welfare (Alarcón *et al.* 2002; Fernández-García *et al.* 2009). *In vitro* pH-Stat protein hydrolysis data is rare in the published aquaculture literature with only rainbow trout (Dimes and Haard 1994) and white shrimp (Ezquerria *et al.* 1997, 1998; Lemos *et al.* 2009) represented. From these publications, a small number of predictive equations exist but are lacking for all other farmed fish species, including gadoids.

### ***Nutritional challenges and opportunities***

The potential for gadoid aquaculture will not come without significant challenges. The single largest nutritional challenge appears to be the high cost and shortage of fish meal on the global market. Gadoids are cold-water marine fish that are predominantly farmed in countries bordering the North Atlantic such as Canada, Norway, Scotland, England and Iceland where their preferred seawater temperatures of 8 to 17°C can be ensured (Bøhle 1974; Jobling 1988). In these cold environments, feed represents the largest production cost of marine fish farming (>50%) and protein is the most expensive component of these feeds. Since gadoids in the juvenile grower phase have relatively high protein requirements ranging from 45 to 60% of the diet (Lall and Nanton 2002; Lall *et al.* 2003; Rosenlund *et al.* 2004; Árnason *et al.* 2010), their diets constitute high proportions of fish meals (>65% of the diet), which are currently in high demand as the primary protein source in aquafeeds. Fish meals have been the protein source of choice

for the aquaculture industry for several decades due to their superior essential amino acid profile, organoleptic properties, n-3 fatty acid content and favorable trace element content and high nutrient bioavailability (Kaushik and Seiliez 2010). However, rising prices, dwindling availability and ecological and socio-economic concerns have meant that replacement of fish meal in marine fish feeds is now critical. Approximately 87% of all small pelagic fish (e.g. anchovy, herring, mackerel, pilchard, sprat, menhaden, sardine and saury) that are captured globally are used to produce fish meal and fish oil that are used to feed farmed animals and pets. A significant proportion (~40%) of these fish meals is used directly for the production of compound aquafeeds for fish farming even though half of these wild stocks are now deemed as fully exploited (Pauly *et al.* 2005; Tacon and Metian 2009). Due to the high cost of fish meal (\$1000-2000/tonne) and the negative impact of fish meal production on wild stocks of these small pelagic fish, current formulations used to feed farmed gadoids and other cold-water marine fish are no longer sustainable - economically or ecologically. As such, gadoid farming makes a net negative contribution to global fish supplies (Naylor *et al.* 2000) as does the farming of salmonids which currently dominate the cold-water marine aquaculture sector. Significant reductions in the use of fish meal in the feeds for cold-water marine fish aquaculture is accepted within the aquaculture industry and has become a private and public-sector priority (Powell 2003; Gatlin *et al.* 2007; Lim *et al.* 2008; Tacon and Metian 2008; Koeleman 2009; Naylor *et al.* 2009; Hardy 2010). In fact, there are now indications that due to the major efforts by the aquaculture industry, salmon farming is now approaching marine protein and oil neutrality (Crampton *et al.* 2010), but additional efforts are still needed as gadoid diets are developed.

Reductions in fish meal use in aquafeeds will not only help marine fish farming become more ecologically sustainable but can also assist the global capture fisheries by reducing pressure on the already over-exploited wild populations. In addition to over-fishing pressures, there are real concerns about entire marine ecosystems collapsing due to climate change, ocean warming and increased ocean acidification (Boyce *et al.* 2010). These environmental issues threaten the very base of the marine food chain (e.g. low-trophic phytoplankton and zooplankton) and it will, undoubtedly, add an additional strain on higher-trophic marine fisheries whose very existence depends on healthy ocean

ecosystems. The simple fact is that consumer demand for seafood products like salmonids and gadoids continues to grow and the wild capture fishery cannot satisfy this demand. It is noteworthy to point out that contrary to popular belief, the conversion efficiency of farmed marine fish is greater than that of their wild counterparts. Pauly (1996) estimated that it takes 4.5 kg of wild small fish to produce 0.45 kg of wild large fish (10:1) while studies have shown that farmed marine fish only require 1.8 kg (less than 2:1). This is due to the fact that farmed fish lines are selectively bred for high growth rate and good feed conversion efficiency, compound aquafeeds are formulated to precisely meet the nutritional needs of the target species with highly digestible, energy-dense ingredients and farmed fish expend considerably less dietary energy searching for food. The conversion by wild fish per unit of product actually reaching the consumer may be even lower than the value reported above given the high amount of wastage that is commonly thrown over-board as non-target species by-catch and/or culls from size grading that never reach the marketplace (Harrington *et al.* 2005), yet are killed none-the-less.

Regardless of the problems associated with inefficient capture fisheries practices, if the marine fish farming sector is to progress towards economic and ecological sustainability, fish meal usage must continue to decline through increased use of other marine, plant and terrestrial based ingredients (Tacon and Metian 2008). To effectively achieve this goal in gadoid feeds, additional research is needed to gain a better understanding of the specific nutrient requirements and digestive capabilities of the major farmed gadoids (cod and haddock) during the juvenile grower phase. This knowledge will be required for the further development of new compound feeds for gadoids that optimize their economic and environmental sustainability, ensure rapid growth and good feed efficiency and promote good fish health, immune response and disease resistance (Watanabe 2002; Farrell *et al.* 2010; Hardy 2010).

As discussed previously, the culture of gadoids is poised to greatly expand in many countries that border the North Atlantic; in particular Canada, Norway, Scotland, England and Iceland where production tonnage is expected to equal or surpass that of salmonid farming within 2 decades (Rosenlund and Skretting 2006; Standal and Utne 2007). This significant production will be accomplished through infrastructure that

currently exists for salmonid farming (e.g. farms and feed companies). Unfortunately, the current diet formulations and commercially available feeds for salmonids are not likely suitable for feeding gadoids. As discussed before, gadoids are known to have higher protein requirements (45-60%), lower tolerance for dietary lipid (12-16%) and cannot utilize high levels of dietary carbohydrates (<17%) (Lall and Nanton 2002; Lall *et al.* 2003; Rosenlund *et al.* 2004; Árnason *et al.* 2010). The most likely cause for the higher protein requirement of gadoids is related to the metabolism of dietary lipid. Unlike farmed salmonids, farmed gadoids store the major proportion of dietary lipid as triacylglycerol (TAG) in the liver (Lie *et al.* 1986; 1988; Jobling *et al.* 1991; Dos Santos *et al.* 1993; Morais *et al.* 2001; Nanton *et al.* 2001) due to a low lipid transport capability (in the form of very low density lipoprotein (VLDL)) from the liver to the muscle and other extra-hepatic tissues and low liver lipid catabolic activity ( $\beta$ -oxidation) in gadoids (Nanton *et al.* 2003). These concerns of higher protein requirements and lower tolerance for dietary lipid and carbohydrate pose considerable nutritional challenges for cost-effective diet formulation for gadoids.

Nutritional development for gadoids does offer some distinct advantages over that of salmonids. Firstly, salmonids must be fed supplemental dietary carotenoids (e.g. astaxanthin and canthaxanthin) to obtain the typical reddish pink flesh colour expected by the consumer (Choubert *et al.* 2009, 2010). These carotenoids are expensive, accounting for up to 20% of feed costs or up to 8% of total production costs (Torrissen 1995; Baker *et al.* 2002) and is highly inefficient with only about 15% actually becoming deposited into the flesh (Buttle *et al.* 2001). Since gadoids are white-fleshed fish, carotenoid supplementation to the diet is not required and thus represents a significant cost advantage. Secondly, unlike salmonids, the gadoid digestive system shows high levels of  $\beta$ -D-N-acetylglucosaminidase activity (Danulat and Kausch 1984; Danulat 1986a,b; Gildberg 2004) which enable it to more efficiently break down and access the nutrients within benthic invertebrates like crustaceans and echinoderms (Lall and Nanton 2002; Morris and Green 2002). As such, gadoids may effectively digest underutilized chitin-rich and ash-rich marine proteins sources of lower trophic levels better than salmonids (Toppe *et al.* 2006), which could represent an additional cost advantage. Moreover, in contrast to salmonids, gadoids do not develop intestinal enteritis when fed some

terrestrial plant protein sources at high levels in the diet (Refstie *et al.* 2006; Olsen *et al.* 2007; Walker *et al.* 2010). Recent data indicates that up to 75% of fish meal can effectively be replaced with plant proteins such as soy and wheat gluten with no negative effects on feed intake, growth rate, feed conversion efficiency or the expression of genes related to cellular stress, protein biosynthesis and energy metabolism (Lie *et al.* 2011). This indicates that the adverse effects of plant-based ANFs on digestion, nutrient absorption and fish health (Storebakken *et al.* 2000; Francis *et al.* 2001; Krogdahl *et al.* 2010) are likely not as severe for gadoids and that these more environmentally sustainable ingredients with a lower cost may be used at higher levels than currently possible in salmonid feeds. It is obvious that significant potential exists to reduce the use of high-cost fish meals in gadoid diets by replacing fish meal with other more economically cost-effective and more environmentally sustainable feed ingredients. Although not a nutritional issue *per se*, the farming of gadoids offers the distinct advantages for salmonid farmers that wish to expand their enterprises as production of gadoids does not require a freshwater larval/juvenile phase and gadoids possess physiological mechanisms (endogenous production of glycerol and anti-freeze glycoproteins) that may permit them to be farmed in marine sites not suitable for farming salmonids due to low winter water temperatures (Goddard and Fletcher 1994).

### **Aims of this thesis**

Limited information exists on the nutrient requirements and the digestion, absorption and retention efficiencies of dietary protein and energy of various feed ingredients and compound feeds when fed to gadoids. With the rapidly rising demand for, and price of, fish meals it is critical to gain a better understanding of how these species utilize dietary protein and energy to enable feeds to be formulated with higher levels of alternate protein sources to reduce the reliance on fish meals. The increased use of alternate feed ingredients to fish meal can affect the nutrient balance of the finished product (Shearer 1994, Kora *et al.* 1995). Therefore, this information is not only critical for the development of feed formulations that promote rapid growth, efficient nutrient utilization and are cost-effective, but also result in fish which have the desirable taste, appearance and texture expected by the consumer. With fish meal supplies more limited

than ever before and with increasing environmental, social and market pressures, developing nutritionally complete diets for the ‘sustainable’ culture of gadoid fish must be done at an unprecedented rate in order to ensure success and achieve the ambitious production goals discussed above.

This thesis presents several studies that were designed to examine the growth potential of gadoid fish at the juvenile grower phase fed practical diets, generate new data on the digestive capacity of juvenile gadoids fed conventional feed ingredients, compound feeds and alternative feed ingredients, build upon some of the known key macronutrient requirements of gadoid fish and establish protocols and predictive regression equations that can be used for *in vitro* rapid screening for protein quality of feed ingredients, specifically for gadoids. The schematic below (Figure 5) shows the outline of this thesis and the relationships between the various studies and how they are linked to each other and build upon one another to address the ultimate research goal of gaining a better understanding of protein and energy nutrition of farmed gadoids during the juvenile grower phase.

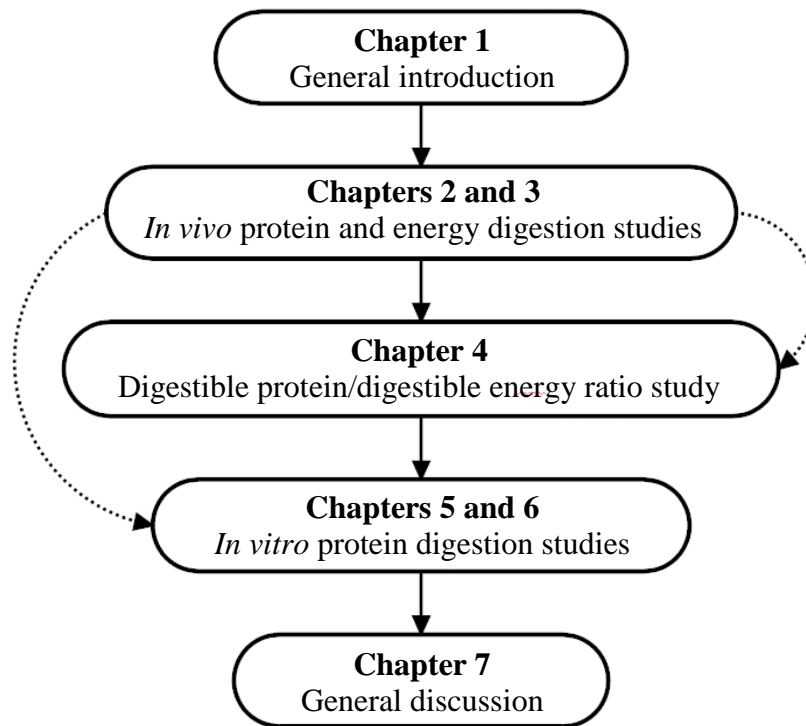

**Figure 5** Thesis outline

The first part of the thesis (**Chapters 2 and 3**) focuses on determining the protein and energy apparent digestibility coefficients (ADCs) for several feed ingredients fed to gadoid fish. A wide range of feed ingredients including fish meals, zooplankton meals, crustacean by-product meals, animal by-product meals and protein meals, concentrates and isolates of plant origin (including oilseeds, pulses and grains) were tested. The data from these chapters will provide new information on the digestive capacity of gadoids when fed both conventional and non-conventional (alternative) feed ingredients and also generated 'gadoid-specific' protein and energy ADCs that were not available in the published literature. The ADC values from **Chapter 2** were critical in order to formulate the experimental diets used to determine the optimum DP/DE ratio further in this thesis (**Chapter 4**). The results of **Chapters 2 and 3** were then further used when generating predictive regression equations in **Chapter 6**. Lastly, the gadoid-specific protein and energy ADCs generated in **Chapters 2 and 3** can be used by international aquafeed companies when formulating and producing new gadoid feeds and also by other researchers conducting nutritional development studies with gadoids.

The major objective of **Chapter 4** was to determine the optimum DP/DE ratio for hatchery-reared gadoids during the juvenile grower phase. Both dietary protein and lipid are highly available sources of digestible energy (DE) for gadoids. However, the use of protein as a dietary energy source is undesirable because of the high cost of protein relative to the lower cost of non-protein energy sources. A proper balance of DP and DE (DP/DE ratio) is necessary to maintain high growth rates, good feed conversion efficiency, improve protein utilization, minimize excessive accumulation of lipid and glycogen in the somatic tissues and liver and minimize undesirable nitrogenous waste output in fish farm effluents. Thus, the DP/DE ratio is one of the most important factors when defining macronutrient requirements for any farmed fish species and it is clear that the requirements for salmonids and other marine fish are not suitable for use in feeds for gadoids. In order to properly examine the effects of feeding diets containing various combinations of protein and non-protein energy and to quantify the optimum DP/DE ratio for juvenile gadoids, the gadoid-specific protein and energy ADCs from **Chapter 2** were necessary to precisely formulate the experimental diets used in **Chapter 4**.



Fish, animal and plant by-products are widely available for use as major sources of dietary protein in gadoid feeds. Conventional *in vivo* methods for assessing their protein quality are based on determination of protein ADC as used in **Chapters 2 and 3**. *In vitro* methods may be more suitable for research and industrial applications as they are relatively inexpensive, require less animals and results can be rapidly obtained. **Chapter 5** was aimed at the development of a working closed-system protocol for producing digestive enzyme fractions extracted from gadoid fish, characterization of the major serine proteolytic digestive enzyme activities and determination of the most suitable substrate concentration [S] to use to measure the *in vitro* degree of protein hydrolysis (DH) of test ingredients. The methodology developed in **Chapter 5** was then applied in **Chapter 6** to measure the *in vitro* protein DH of the same test feed ingredients used to determine the *in vivo* protein ADCs in **Chapters 2 and 3**. The data generated was then used to generate predictive regression equations that are ‘species-specific’ to gadoid fish and can be used for rapid screening of protein quality of existing and potentially new feed ingredients for the further development of cost-effective and more environmentally sustainable feeds for gadoid aquaculture.



## Chapter 2

### **Apparent digestibility of common feed ingredients by juvenile haddock, *Melanogrammus aeglefinus* L.**

*This chapter was published as:*

Tibbetts, S.M., Lall, S.P., Milley, J.E. (2004) Apparent digestibility of common feed ingredients by juvenile haddock, *Melanogrammus aeglefinus* L. *Aquaculture Research* 35, 643-651.

## Abstract

The digestible energy (DE) content and the apparent digestibility coefficients (ADCs) of nutrients in common feed ingredients available in Atlantic Canada for haddock, *Melanogrammus aeglefinus*, feed formulations were determined. Juvenile haddock (mean weight, 93.9±2.1g) were held in tanks equipped with fecal collection columns and fed practical fish meal-based diets for 5 weeks. The experimental diets consisted of a reference diet and six test diets, each containing 30% test ingredient, with all diets being supplemented with chromic oxide (Cr<sub>2</sub>O<sub>3</sub>, 5 g/kg) as the inert digestion indicator. Three marine fish by-products, herring meal (HM), shrimp meal (SM) and crab meal (CRM) and three plant protein supplements, dehulled soybean meal (SBM), canola meal (CAM) and corn gluten meal (CGM) were the test ingredients. The DE content of HM, SBM, CGM, CRM, CAM and SM were 18.3, 17.9, 17.8, 12.4, 10.9 and 8.3 MJ/kg; respectively. Protein ADCs were 95.2, 92.4, 92.7, 83.6, 82.8 and 73.1%; respectively. Organic matter ADCs were 96.5, 88.6, 72.5, 68.4, 59.0 and 54.8%; respectively. Lipid ADCs were 97.9, 83.0, 57.4, 62.0, 87.2 and 55.8%; respectively. Based upon its high crude protein content and nutrient ADC and DE content, properly processed dehulled SBM was found to be a good plant protein supplement to partially replace HM in haddock feeds.

## Introduction

Aquaculture of cold-water gadoids, like haddock, *Melanogrammus aeglefinus*, and cod, *Gadus morhua*, is currently expanding in Atlantic Canada. Limited information exists on their nutrient requirements, digestion, absorption and retention of major nutrients and energy utilization from various feed ingredients and complete feeds (Lall and Nanton 2002). In order to select potential feedstuffs for feed formulation for any fish species, apparent digestibility coefficients (ADCs) of energy-yielding nutrients (starch and sugars, fat, protein, non-starchy polysaccharides) must be measured (Cho and Slinger 1979; Lall 1991). Fish meal comprises the main source of protein in salmonid and marine fish diets and the nutritional value of various fish meals for salmonids has been investigated extensively (Anderson *et al.* 1993; 1997). Several factors affect the utilization of fish meal and crustacean by-product meals, e.g. characteristics of the raw

material (species, freshness, whole fish or scraps, etc.), processing methods, lipid peroxidation and storage conditions of the meal (Tarr and Biely 1972; Pike *et al.* 1990).

The major by-product of crab and shrimp processing is the shell which contains 50-80% chitin, an amino polysaccharide (poly- $\beta$ -(1 $\rightarrow$ 4)-N-acetyl-glucosamine) (Muzzarelli 1977), which has almost the same chemical structure as cellulose (Kumar 2000) and is often incorrectly measured as crude fibre (Calvo-Carrillo *et al.* 1995). As a result, nitrogen from chitin accounts for 10-15% of the total nitrogen in crab and shrimp meals (Li *et al.* 2000). Chitin is not digested by salmonids (Lindsay *et al.* 1984) but it appears to be highly digestible (>90%) by cod (Danulat 1987) and possibly haddock.

Partial replacement of fish meal with plant protein supplements such as dehulled soybean meal (SBM), canola meal (CAM) and corn gluten meal (CGM) or complete replacement with concentrates from these products has been successful in several commercially important salmonid species (Higgs *et al.* 1995; Kaushik *et al.* 1995). Factors limiting the use of plant protein sources include low protein content, high fibre content, amino acid imbalance and the presence of toxins and anti-nutritional factors such as trypsin inhibitor in SBM and tannins, sinapin, phytic acid, urucic acid and glucosinolates in CAM (Krogdahl 1991). These components in feed ingredients may reduce palatability, reduce protein, lipid and energy digestibility (Olli and Krogdahl 1995; Van den Ingh *et al.* 1996) and cause several other undesirable effects when incorporated into fish feeds (see reviews of Storebakken *et al.* 2000; Francis *et al.* 2001). However, plant-based protein sources can provide high-quality protein in fish diets when properly incorporated into feed formulas, supplemented with purified amino acids and properly heated during feed processing.

The objective of this study was to determine the ADCs of protein, organic matter and lipid and the digestible energy (DE) content of local marine by-products (herring, shrimp and crab meals) and plant protein supplements (dehulled SBM, CAM and CGM) when included at 30% of the diet for haddock.

## Materials and methods

### *Experimental conditions and fecal sampling*

Haddock juveniles hatched and reared to 275 days post hatch at the NRCC Aquaculture Research Station, Institute for Marine Biosciences (Halifax, NS, Canada) were used in this study. One hundred and sixty-eight fish were randomly distributed into 14, 100-L cylindro-conical fibreglass tanks, each equipped with a fecal collection column similar to the Guelph system (Guelph, Ont., Canada) (Cho *et al.* 1982) and to those used by Hajen *et al.* (1993a). The fish were acclimated to the tanks and experimental diets for 10 days prior to the trial. The experiment was conducted according to a randomized block design and replicated twice. Each of seven experimental diets was fed to two tanks, each containing 12 fish. At the beginning of the experiment, the haddock had an initial mean weight of  $93.9 \pm 2.1$  g and the biomass density in each tank was approximately  $7 \text{ kg/m}^3$ . Filtered (60 mm), UV-treated seawater (salinity, 28-30 ppt) was supplied to each tank at a flow rate of 2 L/min in a flow-through system and continuously aerated ( $9.5 \pm 0.1$  mg/L dissolved oxygen). Water temperature was maintained thermostatically ( $11.5 \pm 0.1^\circ\text{C}$ ) and monitored every 4 min using a submersible Optic StowAway Temp<sup>TM</sup> data logger (Onset Computer Corporation, Bourne, model WTA08, MA, USA). During the 5-week experimental period, fish were hand-fed to apparent satiety three times daily during the week (0900, 1300, 1600 hours) and twice daily on weekends (0900, 1300 hours). All mortalities were collected, weighed and recorded on a daily basis. Each weekday, after the final feeding (1600 hours), the tanks and fecal collection columns were thoroughly cleaned with a brush to remove any residual particulate matter (feces and uneaten feed). There were no fecal collections made on weekends. Fecal samples were collected each morning (0830 hours) into 250 mL plastic bottles, centrifuged ( $2750 \times g$  for 35min at  $5^\circ\text{C}$ ) and the supernatant discarded. A minimum of 30 g of wet material was collected from each tank and each sample was stored in a sealed container at  $-20^\circ\text{C}$  for the duration of the collection period. Fecal samples were then lyophilized, finely ground and kept frozen at  $-20^\circ\text{C}$  until further analyses.

### *Experimental diets*

A basal diet based on herring meal (HM) (Table1) was formulated according to digestible protein (DP) and DE values of feed ingredients for salmonids (NRC 1993). The test ingredients included HM, shrimp meal (SM), crab meal (CRM), dehulled soybean meal (SBM), canola meal (CAM) and corn gluten meal (CGM) and their proximate composition is given in Table 2. Subsequently, one reference diet and six experimental diets (Table 3) were prepared using the basal diet and test ingredient in a 70:30 percent ratio (w/w basis). The ingredients of the basal diet and all test ingredients were finely ground (<500  $\mu\text{m}$ ) using a Fitz mill (Fitzpatrick, Elmhurst, IL, USA) before being combined with the remaining feed ingredients. Micronutrients (vitamins and minerals) were pre-mixed with ground wheat as a base, using a twin-shell blender (Paterson-Kelly, East Stroudsburg, PA, USA) prior to being added to the main ingredient mixture. All ingredients including the lipid supplement (herring oil) were mixed in a Hobart mixer (Model H600T, Rapids Machinery, Troy, OH, USA) and steam-pelleted into 3.5-mm pellets (California Pellet Mill, San Francisco, CA, USA). The pellets were dried in an air-convection drier at 30°C to form dry, sinking pellets and stored in air-tight containers at -20°C until use. Diets were screened to remove fines prior to feeding.

### *Analytical techniques and statistical procedures*

Experimental diets, test ingredients and lyophilized fecal samples were analyzed in triplicate using the same procedures. Moisture was determined by weight loss after drying for 24 h at 105°C, ash by incineration in a muffle furnace at 550°C for 24h, crude protein (% nitrogen  $\times$  6.25) using the Dumas method (Ebeling 1968) using a Leco nitrogen determinator (model FP-228, Leco, St. Joseph, MI, USA), gross energy using an adiabatic bomb calorimeter (Parr Instrument, Moline, IL, USA), total lipid by ether extraction (Tecator Soxtec System HT2 1045 extraction unit, Hoeganaes, Sweden) following acid (4 N HCl) hydrolysis (Tecator Soxtec System 1047 hydrolysis unit), chromic oxide by chlorine bleach digestion using a micromethod outlined by Suzuki and Early (1991), organic matter was calculated by difference (100 - [moisture + ash]) and carbohydrate was calculated by difference (100 - [moisture + ash + protein + lipid]).

Nutrient ADCs for the reference and test diets were then calculated according to Maynard and Loosli (1969). Using these data, nutrient ADCs were then calculated for the test ingredients using the equation of Forster (1999). Dry matter digestibility was not calculated because when feces are collected from fish held in seawater, there is a considerable amount of non-dietary ash within the dried feces. This non-dietary ash dilutes the concentrations of all fecal constituents and leads to erroneous results for dry matter digestibility; however, its presence in the feces does not affect digestibility estimates of other organic nutrients (Grisdale-Helland and Helland 1998).

Apparent digestibility coefficients were calculated from the average of two replicate tanks receiving each experimental diet. Statistical analyses were performed using analysis of variance (ANOVA) and in the case of a significant difference, treatment means were differentiated using the Tukey's multiple range test (SYSTAT<sup>®</sup> 8.0). All data reported as a percentage (ADC data), was arcsine transformed prior to ANOVA. A 5% level of probability ( $P < 0.05$ ) was chosen in advance to sufficiently demonstrate a statistically significant difference.

## Results and discussion

Apparent digestibility coefficient values (Table 4) and digestible nutrient levels (Table 5) of the marine byproducts and plant protein supplements were evaluated. For fish species such as rainbow trout, *Oncorhynchus mykiss*, Atlantic salmon, *Salmo salar*, coho salmon, *Oncorhynchus kisutch*, Chinook salmon, *Oncorhynchus tshawytscha*, gilthead seabream, *Sparus aurata*, European sea bass, *Dicentrarchus labrax*, red drum, *Sciaenops ocellatus*, and Atlantic cod, protein digestibility in HM is high with ADC values ranging from 87 to 98% (Smith *et al.* 1980; Pfeffer 1982; Lie *et al.* 1988; Cho and Kaushik 1990; Anderson *et al.* 1992; Hajen *et al.* 1993b; McGoogan and Reigh 1996; Alexis 1997; Gomes da Silva and Oliva-Teles 1998; Sugiura *et al.* 1998). Haddock was found to digest the protein in HM equally as well or better (95%) than these species. Likewise, the energy digestibility of HM determined in this study with haddock (93%) falls within the range of 84-98% reported for rainbow trout, Atlantic salmon, gilthead seabream and European sea bass (Smith *et al.* 1980; Cho and Kaushik 1990; Anderson *et al.* 1992; Hajen *et al.* 1993b; Alexis 1997; Gomes da Silva and Oliva-Teles 1998). In



fact, the DE values for HM measured with rainbow trout (18-19 MJ/kg) (Cho and Kaushik 1990; Arzel *et al.* 1999) and with haddock (18.3 MJ/kg) were virtually the same. Our finding on the ADC of lipid in HM with haddock (98%) is in agreement with the high values (90-98%) reported for cold-water species like Atlantic salmon, Atlantic halibut, *Hippoglossus hippoglossus*, rainbow trout and Atlantic cod (Lie *et al.* 1988; Cho and Kaushik 1990; Sigurgisladottir *et al.* 1992; Grisdale-Helland and Helland 1998; Berge *et al.* 1999).

Crab meal was more digestible than SM with ADC values for organic matter, protein, energy and lipid of 68, 84, 83 and 62%, respectively, whereas SM was digested at a lower rate in all cases with ADC values of 55, 73, 66 and 56%. ADC for energy of CRM obtained with haddock (83%) was similar to rainbow trout (85%) (Smith *et al.* 1980). The ADC for energy in SM measured in haddock, however, was low at 66% (DE = 8 MJ/kg). Information on energy ADC of SM measured in other fish species is scarce; however, similar DE values (9-10 MJ/kg) have been reported for shrimp (Somsueb 1993). The protein ADC for CRM was higher for haddock (84%) than rainbow trout (72%) (Smith *et al.* 1980) and may be due to a large difference in ash content of the CRM between the two studies. Typical ash content of CRMs are as high as 41% (Tacon 1987; Johnson 1988; Van Lunen and Anderson 1990), whereas the CRM used in this study had much lower ash content (27%). This higher protein ADC value obtained with haddock may also be due to the utilization of chitin. Haddock, like cod, may indeed possess substantial chitinase activities in their stomach, pyloric caeca and intestine that are not present in other fish species (Danulat 1986a,b). In the case of rainbow trout, chitin digestibility has been shown to be extremely poor (<5%) (Lindsay *et al.* 1984). The apparent higher capacity of haddock to digest chitin compared with other fish species would support our previous observations (Unpublished results) of improved growth rate, feed efficiency and reduced hepatosomatic index in haddock with the addition of 4.7% dietary chitin.

The plant protein supplements that were the most digestible were CGM and SBM with organic matter ADC values of 73 and 89%, respectively, and protein ADC values of 93 and 92%, respectively. Organic matter and protein ADCs for CAM were lower (59 and 83% respectively). The most digestible plant protein supplement, in terms of dietary

energy, was SBM (92%) followed by CGM (81%), whereas the energy in CAM was poorly digested (60%). The ADC for CGM (81%) falls within the range reported for rainbow trout (72-87%) (Smith *et al.* 1980; Cho and Kaushik 1990) and is the same (80%) as that reported for gilthead seabream (Alexis 1997). The value for SBM (92%) exceeds those reported for rainbow trout (66-82%), Atlantic salmon (72-80%), gilthead seabream (45%), European sea bass (69-70%), Murray cod, *Maccullochella peelii peelii* (58%) and red drum (38%) (Smith *et al.* 1980; Cho and Kaushik 1990; McGoogan and Reigh 1996; Alexis 1997; Gomes da Silva and Oliva-Teles 1998; Storebakken *et al.* 1998; De Silva *et al.* 2000; Refstie *et al.* 2000). Lipid ADC in SBM and CAM were 83 and 87%, respectively, which falls within the range reported for rainbow trout of 83-94% (Austreng *et al.* 1980; Cho *et al.* 1982; Hilton and Slinger 1986; Cho and Kaushik 1990) but are higher than reported for Atlantic salmon (71%) by Refstie *et al.* (2000). Lipid content of CGM was low (<2%) and the ADC was also low (57%) compared with other test ingredients.

Dehulled SBM and CGM were utilized significantly better than all other alternative ingredients tested in this study with average protein ADC and DE contents of 92-93% and 18 MJ/kg, respectively. These values are close to, or equal to, those of HM at 95% and 18 MJ/kg, respectively. In comparison with rainbow trout (Cho and Kaushik 1990), CGM is equally as good a source of DE for haddock (both at 18 MJ/kg) with ADC values of 81% reported for both species (Cho and Slinger 1979; Arzel *et al.* 1999). On the other hand, SBM was a superior source of DE for haddock (18 MJ/kg) than for rainbow trout (13 MJ/kg) and other species (11-14 MJ/kg) (Smith *et al.* 1980; Cho and Kaushik 1990; Arzel *et al.* 1999; Hertrampf and Piedad-Pascual 2000). In terms of dietary protein, these two ingredients were well utilized by haddock in comparison with other important fish species (salmonids, bass, rockfish, seabream) having a range of protein ADCs (with our value for haddock) for CGM and SBM of 82-97% (93%) and 75-97% (92%) respectively (Cho and Slinger 1979; Smith *et al.* 1980; Pfeffer 1982; Cho and Kaushik 1990; Hajen *et al.* 1993b; Nengas *et al.* 1995; Alexis 1997; Lupatsch *et al.* 1997; Refstie *et al.* 1997; Gomes da Silva and Oliva-Teles 1998; Sugiura *et al.* 1998; Yamamoto *et al.* 1998; Lanari *et al.* 1999; Small *et al.* 1999; Refstie *et al.* 2000; Papatryphon and Soares Jr 2001; Lee 2002).

The results suggest that CAM was poorly utilized by haddock with an organic matter ADC of 59%, which was similar to values reported for Chinook salmon (54-59%) (Hajen *et al.* 1993b). Protein ADC of CAM was also lower (83%) than the other plant ingredients and, in fact, the values reported for rainbow trout (Hilton and Slinger 1986), turbot (Burel *et al.* 2000) and haddock were the same at 83%. Burel *et al.* (2000) also reported that heat-treating of CAM increased its protein ADC from 83 to 92% for turbot but this would increase the cost to the product. It appears that haddock utilize the energy in CAM (11 MJ/kg) at the same rate as Chinook salmon and rainbow trout (11 MJ/kg) (Smith *et al.* 1980; Anderson *et al.* 1992). This corresponds to a fairly low energy ADC value of about 60% for all three species. Much discrepancy exists on energy ADC in CAM for rainbow trout with values ranging from very low to moderate (45-75%) (Cho *et al.* 1982; Hilton and Slinger 1986; Cho and Kaushik 1990). Energy ADC for haddock and Australian silver perch, *Bidyanus bidyanus*, were also similar at 60 and 58% respectively (Allan *et al.* 2000). Lipid ADC values reported for CAM in rainbow trout (92%) are high (Cho *et al.* 1982; Hilton and Slinger 1986) and similar to that reported here for haddock (87%). Like SM, the CAM used in this study was high in ash (7%) and fibre (11%), compared with averages of 4% (ash) and 4% (fibre) for the other plant ingredients. Mwachireya *et al.* (1999) concluded that high levels of fibre have the greatest adverse effects on digestibility of canola products for rainbow trout and this also seems to be the underlying reason for low digestibility in haddock, turbot and most other species examined.

## **Conclusions**

Due to high crude protein content, nutrient ADC and DE content, properly processed dehulled SBM is a good plant protein supplement to partially replace HM in haddock feeds. The relatively high DP and DE content, low ash content and good feed attractant properties makes properly processed CRM a good marine fish by-product alternative to partially replace HM in haddock diets. Future research should be directed to verify the chitin digestibility and to determine the amino acid availability of CRM and to further improve the processing conditions that will retain free amino acids and their associated feed attractant properties. SM and CAM have limited potential for use in

haddock diets due to their high ash and fibre contents, low DE content and poor organic matter and protein ADC values. Additional effort is needed to improve the processing of these feed ingredients to increase the digestibility and nutritive value of these products.

## **Acknowledgments**

Financial and logistical support for this work was provided by Heritage Aquaculture Limited (Blacks Harbour, NB, Canada), NRCC's Industrial Research Assistance Program (Halifax, NS, Canada), St Laurent Gulf Products (Caraquet, NB, Canada) and staff at NRCC's Aquaculture Research Station (Halifax, NS, Canada) in particular Steven Leadbeater, Ronald Melanson, Brian Blanchard and Randy Peach. The critical review and valuable suggestions of Dr. Dominic Nanton during the preparation of this manuscript is also greatly appreciated.

**Table 1** Composition of the basal diet (without oil)

Ingredient	g/kg
Herring meal (70% CP) <sup>a</sup>	460.0
Wheat gluten meal <sup>b</sup>	50.0
CPSP-G <sup>c</sup>	50.0
Wheat middlings <sup>b</sup>	187.0
Whey powder <sup>d</sup>	70.0
Corn starch (pre-gel) <sup>e</sup>	61.0
Vitamin pre-mix <sup>f</sup>	19.5
Mineral pre-mix <sup>g</sup>	19.5
Choline chloride <sup>h</sup>	3.0
Total	920.0

<sup>a</sup>Corey Feed Mills (Fredericton, NB, Canada).

<sup>b</sup>Dover Mills (Halifax, NS, Canada).

<sup>c</sup>Concentre proteique soluble de poisson (soluble fish protein concentrate) (Sopropêche, France).

<sup>d</sup>Farmers Co-operative Dairy (Truro, NS, Canada).

<sup>e</sup>National Starch and Chemical (Bridgewater, NJ, USA).

<sup>f</sup>Vitamin A, 8000 IU; vitamin D<sub>3</sub>, 4500 IU; vitamin E, 300 IU; vitamin K<sub>3</sub>, 40 mg/kg; thiamin, 50mg/kg; riboflavin, 70 mg/kg; pantothenate, 200 mg/kg; biotin, 1.5 mg/kg; folic acid, 20 mg/kg; vitamin B<sub>12</sub>, 0.15 mg/kg; niacin, 300 mg/kg; pyridoxine, 20 mg/kg; ascorbic acid, 300 mg/kg; inositol, 400 mg/kg; butylated hydroxy toluene, 15 mg/kg; butylated hydroxy anisole, 15 mg/kg.

<sup>g</sup>Manganous sulphate, 40 mg/kg; ferrous sulphate, 30 mg/kg; copper sulphate, 5 mg/kg; zinc sulphate, 75 mg/kg; sodium selenite, 1 mg/kg; cobalt chloride, 2.5 mg/kg; sodium fluoride, 4 mg/kg.

<sup>h</sup>US Biochemical (Cleveland, OH, USA).

**Table 2** Proximate composition of the six experimental feed ingredients

Nutrient ( <i>as-fed</i> basis)	Herring meal <sup>a</sup>	Crab meal <sup>b</sup>	Shrimp meal <sup>c</sup>	Soybean meal <sup>a</sup>	Canola meal <sup>d</sup>	Corn gluten meal <sup>a</sup>
Moisture (%)	8.5	8.5	5.8	6.6	11.4	7.5
Ash (%)	14.4	26.7	37.7	5.7	6.9	1.4
Organic matter <sup>e</sup> (%)	77.1	64.8	56.5	87.7	81.7	91.1
Crude protein (%)	69.7	50.3	40.6	46.3	38.3	65.8
Lipid (%)	10.2	7.1	4.5	5.5	3.8	1.8
Carbohydrate <sup>f</sup> (%)	0.0	7.4	11.4	35.9	39.6	23.5
Gross energy (MJ/kg)	19.8	15.0	12.5	19.5	18.2	22.1

<sup>a</sup>Corey Feed Mills (Fredericton, NB, Canada).

<sup>b</sup>St Laurent Gulf Products (Caraquet, NB, Canada).

<sup>c</sup>Island Fisherman's Co-op (Lemeque, NB, Canada).

<sup>d</sup>Canbra Foods (Lethbridge, AB, Canada).

<sup>e</sup>Organic matter = 100 - (moisture + ash).

<sup>f</sup>Carbohydrate = 100 - (moisture + protein + lipid + ash).

**Table 3** Formulation of the seven experimental diets

Ingredient (g/kg)	Reference	Herring meal	Crab meal	Shrimp meal	Soybean meal	Canola meal	Corn gluten meal
Basal diet	915.4	615.4	615.4	615.4	615.4	615.4	615.4
Test ingredient	0.0	300.0	300.0	300.0	300.0	300.0	300.0
Herring oil	79.6	79.6	79.6	79.6	79.6	79.6	79.6
Chromic oxide	5.0	5.0	5.0	5.0	5.0	5.0	5.0
Total	1000.0	1000.0	1000.0	1000.0	1000.0	1000.0	1000.0
<i>Analysis (as-fed basis)</i>							
Moisture (%)	10.3	9.5	8.3	7.7	9.3	9.0	8.8
Ash (%)	9.1	10.5	13.3	16.3	8.2	8.2	6.6
Crude protein (%)	44.2	51.1	46.5	42.4	43.7	41.0	49.6
Lipid (%)	13.9	14.1	13.4	14.0	13.7	12.9	14.1
Carbohydrate <sup>a</sup> (%)	22.5	14.8	18.5	19.6	25.1	28.9	20.9
Gross energy (MJ/kg)	20.6	20.9	19.9	19.0	20.8	20.5	21.7

<sup>a</sup>Carbohydrate = 100 - (moisture + protein + lipid + ash).

**Table 4** Apparent digestibility coefficients (%) of major nutrients in the six experimental feed ingredients<sup>1</sup>

Ingredient	Organic matter	Energy	Protein	Lipid
Herring meal	96.5±2.7 <sup>a</sup>	92.6±3.8 <sup>a</sup>	95.2±0.6 <sup>a</sup>	97.9±1.3 <sup>a</sup>
Crab meal	68.4±4.9 <sup>bc</sup>	82.7±0.8 <sup>b</sup>	83.6±0.8 <sup>b</sup>	62.0±4.6 <sup>b</sup>
Shrimp meal	54.8±7.4 <sup>d</sup>	66.2±3.9 <sup>c</sup>	73.1±1.7 <sup>c</sup>	55.8±3.4 <sup>b</sup>
Soybean meal	88.6±3.4 <sup>a</sup>	92.0±2.2 <sup>a</sup>	92.4±1.6 <sup>a</sup>	83.0±6.0 <sup>a</sup>
Canola meal	59.0±2.6 <sup>cd</sup>	60.1±1.2 <sup>d</sup>	82.8±1.7 <sup>b</sup>	87.2±1.6 <sup>a</sup>
Corn gluten meal	72.5±0.6 <sup>b</sup>	80.8±1.1 <sup>b</sup>	92.7±0.3 <sup>a</sup>	57.4±2.9 <sup>b</sup>

<sup>1</sup>Values within each column having different superscript letters are significantly different (P<0.05).



**Table 5** Total and digestible contents<sup>1</sup> of major nutrients in the six experimental feed ingredients (*as-fed* basis)

Ingredient	Organic			
	matter (%)	Energy (MJ/kg)	Protein (%)	Lipid (%)
<b>Herring meal</b>				
<i>Total</i>	77.1	19.8	69.7	10.2
<i>Digestible</i>	74.4	18.3	66.4	10.0
<b>Crab meal</b>				
<i>Total</i>	64.8	15.0	50.3	7.1
<i>Digestible</i>	44.3	12.4	42.0	4.4
<b>Shrimp meal</b>				
<i>Total</i>	56.5	12.5	40.6	4.5
<i>Digestible</i>	31.0	8.3	29.7	2.5
<b>Soybean meal</b>				
<i>Total</i>	87.7	19.5	46.3	5.5
<i>Digestible</i>	77.7	17.9	42.8	4.6
<b>Canola meal</b>				
<i>Total</i>	81.7	18.2	38.3	3.8
<i>Digestible</i>	48.2	10.9	31.7	3.3
<b>Corn gluten meal</b>				
<i>Total</i>	91.1	22.1	65.8	1.8
<i>Digestible</i>	66.0	17.8	61.0	1.0

<sup>1</sup>Digestible nutrient content = total nutrient content × ADC, where ADC is the apparent digestibility coefficient.



# Chapter 3

## **Apparent protein and energy digestibility of common and alternative feed ingredients by Atlantic cod, *Gadus morhua* (Linnaeus, 1758).**

*This chapter was published as:*

Tibbetts, S.M., Milley, J.E., Lall, S.P. (2006) Apparent protein and energy digestibility of common and alternative feed ingredients by Atlantic cod, *Gadus morhua* (Linnaeus, 1758). *Aquaculture* 261, 1314-1327.

## Abstract

Studies were conducted with Atlantic cod, *Gadus morhua* (L.), to determine the apparent digestibility coefficients (ADCs) of protein and energy and the digestible energy (DE) content in feed ingredients widely available in Canada. We also tested the assumption of “independency” used in digestibility studies. The feed ingredients included two fish meals (herring, anchovy), one zooplankton meal (whole krill), two crustacean by-product meals (crab, shrimp), two animal by-product meals (poultry by-product, hydrolyzed feather), six oilseed meals (soybean, soy protein concentrate, soy protein isolate, canola, canola protein concentrate, flaxseed), two pulse meals (white lupin, pea protein concentrate) and two cereal grain meals (corn gluten, wheat gluten). Protein ADCs were high for wheat gluten meal (99.9%), soy protein concentrate (98.6%), soy protein isolate (97.4%), whole krill meal (96.3%), herring meal (93.3%), soybean meal (92.3%), anchovy meal (92.2%), pea protein concentrate (89.8%), white lupin meal (89.7%), crab meal (89.4%), canola protein concentrate (88.8%) and corn gluten meal (86.3%); mid-range for poultry by-product meal (80.2%) and canola meal (76.0%); and low for shrimp meal (66.7%), hydrolyzed feather meal (62.4%) and flaxseed meal (50.2–55.0%). Energy ADC was high for whole krill meal (96.3%), wheat gluten meal (95.4%), soy protein concentrate (94.9%), herring meal (92.8%), soy protein isolate (92.1%), soybean meal (88.1%) and anchovy meal (86.4%); mid-range for canola protein concentrate (83.3%), corn gluten meal (82.7%), crab meal (82.4%), pea protein concentrate (76.7%) and white lupin meal (75.3%); and low for poultry by-product meal (71.0%), canola meal (60.6%), hydrolyzed feather meal (58.9%), shrimp meal (41.4%) and flaxseed meal (21.2–37.4%). From the protein ADC data, results clearly showed that the basal diet and test feed ingredients were digested independently of one another in nearly all cases, the only exceptions being for those diets containing test ingredients of very high (>99%, wheat gluten) or very low (<67%, hydrolyzed feather and flaxseed) protein ADCs. In the case of DE, the basal diet and test feed ingredients were digested independently in all test diets without exception.

## Introduction

In recent years, marine culture of gadoids has expanded in Eastern Canada and Western Europe. The production of species like Atlantic cod is expected to reach 140–180,000 tonnes by the year 2010 (Rosenlund and Skretting 2006). These fish are known to have a high protein requirement (50–60%) (Lall *et al.* 2003; Rosenlund *et al.* 2004) but limited information is available on digestion of major nutrients and energy from various feed ingredients (Tibbetts *et al.* 2004; Kim *et al.* 2006). Selection of potential ingredients for feed formulation for any fish species requires knowledge of the apparent digestibility coefficients (ADCs) of energy-yielding nutrients (starch and sugars, fat, protein, non-starchy polysaccharides). Fish meal provides the main source of protein in salmonid and marine fish diets. The nutritional value of various fish meals for salmonids grown in Canada has been investigated extensively (Anderson *et al.* 1997; Lall and Anderson 2005). World-wide fish meal use for aquafeeds will reach 4 million tonnes by 2015, representing >66% of the expected global supply (New and Wijkström 2002). With this ever-growing demand for high-quality fish meals, fish feeds must increasingly be formulated with alternate protein sources from marine, animal or plant origin that are both economical and highly digestible (see review of Hardy 1996). The use of these alternatives in on-growing diets must still be able to support similar fish performance and, concurrently, have little or no adverse effects upon fish health and the environment.

Several factors can affect protein quality and the nutrient profile of fish, zooplankton, crustacean and animal by-product meals. These include characteristics of the raw material (species, freshness, whole animal or scraps), processing of the raw ingredients such as the drying process and temperature, lipid peroxidation and storage conditions of the meal (Pike 1991). The major by-product of crustacean processing is the shell which contains 50–80% chitin, an amino polysaccharide (poly- $\beta$ -(1 $\rightarrow$ 4)-N-acetylglucosamine). The natural diet of cod consists of >37% chitin-rich crustaceans and echinoderms including crabs, shrimps and brittle stars (see Lall and Nanton 2002). Cod naturally produce significant concentrations of the digestive enzyme chitinase (Danulat and Kausch 1984) and *in vivo* chitin digestibility may be as high as 90% for cod (Danulat 1987). Accordingly, crustacean by-products have been identified as good candidates to

replace fish meal in diets for Atlantic cod (Toppe *et al.* 2006). At the same time, crustacean by-product meals are usually high in ash content (>20%), which can adversely affect digestibility of fish feeds (NRC 1993).

Poultry by-product and hydrolyzed feather meals are produced from the wastes generated by the poultry processing industry. Production processes are similar to that of fish meal with an extra  $\text{Ca}(\text{OH})_2$  digestion in the production of hydrolyzed feather meal. These animal by-product meals are generally high in crude protein (60–80%); however, they tend to be methionine deficient. Poultry by-product meal can also be high in ash (>15%) as a result of high bone content and is often variable in proximate composition. Protein digestibility can be quite low for hydrolyzed feather meal due to high levels of keratin (Dong *et al.* 1993; Hardy and Barrows 2002).

Partial replacement of fish meal with plant protein supplements or complete replacement with concentrates from these products has been successful in several commercially important salmonid species (Higgs *et al.* 1995; Kaushik *et al.* 1995) and turbot (Regost *et al.* 1999). Factors limiting the use of plant protein sources include low protein content, high fiber content, an amino acid imbalance, poor palatability and the presence of anti-nutritional factors or toxicants (e.g. protease inhibitors, lectins, phytic acid and/or erucic acid, sinapin, saponins, phytoestrogens, alkaloids, tannins, cyanogens, glucosinolates). These factors adversely affect digestion, absorption, physiological utilization of protein and amino acids, lipids and fatty acids and minerals and cause several other undesirable effects when incorporated into fish feeds (see review of Francis *et al.* 2001). Plant-based protein sources, however, can provide high nutritional value in fish diets when properly incorporated into feed formulations, supplemented with purified amino acids and feed attractants and properly heated during feed processing. Unfortunately, many of the modified plant-based feed ingredients (protein concentrates, isolates and glens) become cost-prohibitive in least-cost ration formulations (Hardy 1996).

The objectives of the present study were to: (1) determine the apparent digestibility coefficients (ADCs) of protein and energy and the digestible energy (DE) content of a wide range of feed ingredients available in Canada including fish meals, zooplankton meals, crustacean by-product meals, animal by-product meals and plant-

based meals when included at 30% in the diet for Atlantic cod and (2) test the assumption that the basal mix portion of the test diet (70%) and the test feed ingredient (30%) are digested independently of one another (Cho *et al.* 1982).

## **Materials and methods**

### *Fish*

Atlantic cod juveniles were cultured at the NRCC Institute for Marine Biosciences, Marine Research Station (Halifax, Nova Scotia) for use in this study. Three hundred and sixty of these fish ( $89.9 \pm 4.0$  g average weight) were temperature acclimated in a single 2000 L circular fiberglass tank with flow-through (30 L/min), filtered (30  $\mu$ m) seawater (salinity, 28–30 ppt). Temperature acclimation involved a gradual increase in water temperature (0.5°C per day) from 4 to 12°C over a 3-week period. During this period, the fish were hand-fed EWOS™ 5.0 mm Marine Feed (EWOS Canada, Surrey, BC, Canada) twice daily (0900 and 1600 h) to apparent satiation. The proximate composition (*as-fed* basis) of this diet was: moisture 63 g/kg, crude protein 551 g/kg, lipid 119 g/kg, ash 106 g/kg, and gross energy 21 MJ/kg.

### *Experimental diets*

A practical, fish meal-based basal diet (Table 1) was formulated according to digestible protein (DP) and digestible energy (DE) values of feed ingredients for haddock (Tibbetts *et al.* 2004). Seventeen experimental diets were subsequently produced containing a mixing ratio (w/w basis) of basal diet (69.75%) and test feed ingredient (29.75%). One additional diet containing 99.5% basal diet with no test feed ingredient was also produced and served as the reference diet. All 18 experimental diets were supplemented with chromic oxide (Cr<sub>2</sub>O<sub>3</sub>, 5 g/kg) as the inert digestion indicator (Austreng 1978).

The test feed ingredients consisted of two fish meals (herring, anchovy), one zooplankton meal (whole krill), two crustacean by-product meals (crab, shrimp), two animal by-product meals (poultry by-product, hydrolyzed feather), six oilseed meals (soybean, soy protein concentrate, soy protein isolate, canola, canola protein concentrate, flaxseed), two pulse meals (white lupin, pea protein concentrate) and two cereal grain

meals (corn gluten, wheat gluten). Their international feed number, proximate composition, gross energy content and supplier are given in Table 2. Dry ingredients of the basal diet and all test feed ingredients were finely ground (<800 µm) using a Perten Laboratory Mill (Model 3100, Perten Instruments, Huddinge, Sweden). Micronutrients (vitamins and minerals) were pre-mixed with ground wheat as a base, using a twin-shell blender (Paterson-Kelly, East Stroudsburg, PA, USA) prior to being added to the main ingredient mixture. All ingredients were mixed in a Hobart mixer (Model H600T, Rapids Machinery Co., Troy, OH, USA) and steam pelleted into 4.0 mm pellets (California Pellet Mill Co., San Francisco, CA, USA). The pellets were dried in a forced-air drier at 80°C for 90 min to form dry, sinking pellets and stored in air-tight containers at -20°C until use. Diets were screened to remove fines prior to feeding.

### *Digestibility system and fecal collection*

After the 3-week temperature acclimation, the fish were randomly distributed into a digestibility system consisting of 12 tanks (120 L capacity) each equipped with a fecal collection column (Figure 1), which was a modification of the Guelph system (Cho *et al.* 1982). The modifications were made in order to (1) utilize a single, circular fiberglass tank as the experimental unit rather than triple, grouped rectangular tanks and (2) increase the rate and quantity of fecal recovery by repositioning the fecal collection column directly below the drain at the bottom of the tank. This modification increased the efficiency of fecal settlement by eliminating any requirement for horizontal flow. A gate valve was installed at the connection between the tank and the fecal collection column so that the column could be isolated from the effluent water and removed from the system for cleaning at the end of each day without any disruption in water flow to the fish.

The fish were acclimated to these tanks and the experimental diets for 2 weeks prior to beginning the trial. The experiment was conducted according to a randomized block design and replicated twice. Each of the 18 experimental diets was fed to two tanks, each containing 30 fish with an initial mean weight of 89.9±4.0 g. Filtered (30 µm), UV-treated seawater (salinity, 28–30 ppt) was supplied to each tank at a flow rate of 3 L/min in a flow through system and continuously aerated (8.6±0.8 mg/L dissolved oxygen; 91±6% gas saturation). The water temperature was maintained thermostatically



( $11.9 \pm 0.2$  °C) and monitored daily. The rearing temperature of 12°C is within the preferred zone of 9–17°C for Atlantic cod where gastric evacuation rate, appetite and feeding rates are maximized (Jobling 1988). During the 10-week experimental period, fish were hand-fed to apparent satiety 3 times daily during the week (0900, 1300, 1600 h) and twice daily on weekends (0900, 1300 h). Any dead or moribund fish were collected, weighed and recorded on a daily basis. Each week-day, after the final feeding (1600 h), the tanks and fecal collection columns were thoroughly cleaned with a brush to remove any residual particulate matter (feces and uneaten feed). There were no fecal collections made on weekends. Fecal samples were collected each morning (0830 h) into 250 mL plastic bottles, centrifuged (4000 rpm [ $2750 \times g$ ] for 20 min at 4°C) and the supernatant carefully decanted and discarded. Approximately 17–18 h elapsed between the last feeding and the fecal collection. A minimum of 40 g of wet material was collected from each tank (20 g at each of 2 consecutive collection periods) and each sample was stored in a sealed container at –20°C for the duration of the collection period. Fecal samples were lyophilized, finely ground and stored at –20°C until further analyses.

### *Analytical techniques, calculations and data analyses*

Test feed ingredients, experimental diets and lyophilized fecal samples were analyzed in duplicate using the same procedures. Moisture was determined by drying in an oven at 105°C for 18 h and ash by incineration in a muffle furnace at 550°C for 18 h (Woyewoda *et al.* 1986). Crude protein (% nitrogen  $\times 6.25$ ) was measured by the Dumas method (Ebeling 1968) using a Leco nitrogen determinator (Model FP-528, Leco Corporation, St. Joseph, MI, USA). Total lipid was determined using a modified Bligh and Dyer (1959) method. Organic matter was calculated by difference ( $100 - [\text{moisture} + \text{ash}]$ ) and carbohydrate was calculated by difference ( $100 - [\text{moisture} + \text{ash} + \text{protein} + \text{lipid}]$ ). Gross energy was measured using an isoperibol oxygen bomb calorimeter (model 6200, Parr Instrument Company, Moline, IL, USA) equipped with a Parr 6510 water handling system for closed-loop operation. Chromic oxide content of experimental diets and fecal samples was determined by flame atomic absorption spectrophotometry using an AAnalyst 300 atomic absorption spectrophotometer (Perkin-Elmer, Norwalk, CT,

USA) following a microwave acid digestion procedure as described by Peach (2005, pp. 52–54) using a Multiwave sample preparation platform system (Perkin-Elmer, Norwalk, CT, USA).

Diet digestibility (% dry matter digestibility) for the reference and test diets was calculated as follows:

$$\text{Diet digestibility (\%)} = 100 - (100 \times [\text{Cr}_2\text{O}_3 \text{ diet}/\text{Cr}_2\text{O}_3 \text{ feces}])$$

Apparent digestibility coefficients (ADCs) of protein and energy for the reference and test diets were calculated according to Maynard *et al.* (1979 p. 41) as follows:

$$\% \text{ ADC} = 100 - (100 \times [\text{Cr}_2\text{O}_3 \text{ diet}/\text{Cr}_2\text{O}_3 \text{ feces}] \times [\text{nutrient feces}/\text{nutrient diet}])$$

Using these data, protein and energy ADCs for the single test feed ingredients were calculated according to Forster (1999).

$$\% \text{ ADC} = ([a + b] \times \text{ADC test diet} - [a] \times \text{ADC reference diet}) \times b^{-1}$$

a = nutrient contribution of reference diet to nutrient content of test diet

b = nutrient contribution of test ingredient to nutrient content of test diet

To calculate the predicted test diet ADC, the following formula was used:

$$\text{Test diet protein ADC or DE} = ([0.7 \times \text{reference diet protein ADC or DE}] + [0.3 \times \text{test ingredient protein ADC or DE}])$$

Mean protein and energy ADC (or DE)  $\pm$  standard error (SE) were calculated from the average of 2 replicate tanks receiving each experimental diet. Statistical analyses were performed using analysis of variance, ANOVA (SYSTAT<sup>®</sup> 8.0) with a 5% level of probability (P<0.05) selected in advance to sufficiently demonstrate a statistically significant difference.

## **Results and discussion**

### *Composition of test feed ingredients*

The proximate composition and gross energy content of the 17 test feed ingredients are reported in Table 2 along with their international feed numbers. The

moisture content of the feed ingredients ranged between 5 and 12%. The crude protein (68 and 75%) and lipid (10%) content of the fish meals are in the typical range of 55–75% and 5–10%, respectively (Hardy 1996). The ash values were as expected with herring meal at 10% and anchovy meal at 16% (NRC 1993). Since herring meal contains higher protein and lower ash than anchovy meal, the gross energy content of the herring meal was about 2 MJ/kg higher than anchovy meal (21 vs. 19 MJ/kg). The krill meal used in this study was produced by finely grinding (<800 µm) whole freeze-dried krill (*Euphausia superba*) and thus the proximate composition was quite different from that found in commercially produced krill meals. The earlier work of Storebakken (1988) reported a proximate composition of 62% crude protein, 12% lipid, 16% ash and 5% chitin in krill. Typically, krill meals produced from various species contain in the range of 33–55% protein, 15–20% lipid and 15–28% ash (Hardy and Barrows 2002). The whole krill meal used here contained considerably higher protein (72%), lower lipid (5%) and had an ash content within the range reported (17%). The crab meal used in this study was provided by a local company that has made significant improvements in processing of Atlantic snow crab (*Chionoecetes opilio*) over the years. Crab meals typically contain 32% protein and 41% ash (NRC 1993) while the crab meal used in this study had a much higher protein (54%) and lower ash (23%) content. The crude protein (37%) and lipid (3.5%) contents of the shrimp meal were close to expected (Hardy 1996; NRC 1993), whereas the ash content was very high (38%). Most shrimp meals typically contain 18–27% ash (Hardy 1996; NRC 1993). The poultry by-product meal used in this study contained 15% lipid, 11% ash and 66% crude protein. Typically, poultry by-product meals contain 58–60% protein and 14–16% ash (Hardy 1996; Hardy and Barrows 2002). The hydrolyzed feather meal contained the expected (80–85%) protein level (83%) but higher levels of lipid (8%) and ash (4%) where typical levels are 5 and 3%, respectively (NRC 1993; Hardy and Barrows 2002). The composition of soybean meal and canola meal were as expected at 47 and 39% protein, 2 and 3% lipid and 6 and 7% ash, respectively (Hardy 1996). Canola and soy protein concentrates are typically high (55–80%) in protein (Hardy 1996) and the products used in this study were in that range (61 and 69%, respectively). As expected, the protein content of the soy protein isolate was much higher at 86%. Further processing of these plant-based ingredients increased the

gross energy (MJ/kg) contents (soybean meal [17], soy protein concentrate [19], soy protein isolate [21] and canola meal [18], canola protein concentrate [19]). The pea protein concentrate used in this study was an air-classified protein concentrate and contained higher protein (49%) than regular pea meals which contain <25% protein (Hardy 1996). The white lupin meal contained 38% protein, which is in the typical range (35–43%) for dehulled lupin seeds (Hardy 1996). Both pulse meals contained relatively high lipid (4 and 6%), low ash (3 and 5%) and high gross energy (19 MJ/kg), which is comparable to some fish meals and other plant protein concentrates. Crude protein and lipid content of the corn gluten meal were slightly higher than typically reported (62 and 4%) and may be the result of the slightly lower ash (1%) content (NRC 1993). The wheat gluten meal used in this study was typically high (79%) in protein (Hardy 1996) and very low in lipid (2%) and ash (0.5%). The flaxseed meal was produced by finely grinding (<800 µm) flaxseed press-cake and it contained relatively low amounts of protein (<31%) and high carbohydrate (43%), which was similar to canola meal (45%). It should be noted that differences in proximate composition of test feed ingredients do exist from batch to batch given the variations in the season of harvest/catch of the raw materials and processing conditions used by various production plants. In addition to differences in their proximate composition, differences in digestibility also occur in feed ingredients that appear to be the same. These effects and also the effect of fecal collection method on ADC values will be discussed further.

### *Survival and feed acceptance*

Over the 10-week experimental period, fish survival was high on all diets (96–100% survival). It was observed that all diets were accepted equally well by the fish with the exception of diets containing zooplankton meals, crustacean by-product meals and pea protein concentrate. The zooplankton and crustacean meals induced a positive feeding response. The diet containing pea protein concentrate was not readily accepted by the fish. This can likely be attributed to the presence of soyasaponin 1 which occurs naturally in peas and is described as having a bitter, astringent and metallic flavor (Price *et al.* 1985).

### *Test diet composition and digestibility*

The proximate composition, gross energy content and dry matter diet digestibility of the experimental diets are shown in Table 3. All diets had moisture contents in the range of 8 to 10%. Protein and energy content ranged from 44 to 61% and from 18 to 21 MJ/kg, respectively and reflected the protein and energy contents of the test ingredients. The ash content was in the range of 5 to 11% for the experimental diets with the exception of the diet containing shrimp meal (15%). Digestibility of the reference diet was 76% and most test diets were similar to or higher than that value (range, 73–81%), with the exceptions of test diets containing white lupin meal, hydrolyzed feather meal, canola meal, shrimp meal and flaxseed meal (range, 53–71%). This is likely due to high levels of ash (>38%) in shrimp meal, carbohydrate (>40%) in canola, flaxseed and white lupin meals and keratin protein in hydrolyzed feather meal. There were 2 consecutive fecal collection periods for fish fed all experimental diets and ADCs of each diet at the 2 collection periods were compared by ANOVA. No significant differences ( $P>0.05$ ) between collection periods, with the exception of the diet containing flaxseed meal were observed; accordingly, data for periods 1 and 2 were pooled for the remaining 17 experimental diets. For the diet containing flaxseed meal, there was a significant period effect ( $P<0.05$ ) where the diet ADC for period 1 was 53% but had significantly improved to 59% by period 2. As a result, all further data analysis for this diet was treated separately and denoted as flaxseed meal (period 1) and flaxseed meal (period 2), respectively. The flaxseed meal used in this study was not a commercial product, rather it was prepared in our lab by finely grinding press cake after oil extraction and was not dehulled. This product likely was quite high in indigestible fiber (essentially “bulk”), which promoted a laxative effect and had a pronounced effect on fecal output, as has been observed with European seabass (Dias *et al.* 1998). Thus, it is not surprising that diet digestibility was low. The significant increase in diet ADC from 53% in period 1 to 59% in period 2 indicates that the fish gut microflora may have adapted to this dietary stressor by increasing in population in the presence of the elevated level of dietary fiber, however, there is no evidence in the literature to support this claim. If these fish were kept on this diet for a longer period of time, it is doubtful that the diet ADC would

continue to improve significantly given the cold-water, carnivorous nature of Atlantic cod.

### *Fish meals*

Protein ADCs for the fish meals were high (Table 4). The value for herring meal (93%) is similar to that previously reported for haddock (*Melanogrammus aeglefinus*) (95–96%) (Tibbetts *et al.* 2004; Kim *et al.* 2006) and salmonids such as rainbow trout (*Oncorhynchus mykiss*), Atlantic salmon (*Salmo salar*), coho salmon (*Oncorhynchus kisutch*) and Chinook salmon at 89–96% (Anderson *et al.* 1997; Hajen *et al.* 1993; Sugiura *et al.* 1998; Burel *et al.* 2000; Cheng and Hardy 2002). The value for anchovy meal (92%) is similar to those reported for salmonid species, which is in the range of 86–94% (Anderson *et al.* 1995; Hajen *et al.* 1993; Sugiura *et al.* 1998, 2000; Thiessen *et al.* 2004; Glencross *et al.* 2005). Protein ADCs of fish meals measured with cod are also similar to those reported for turbot (*Psetta maxima*), seabass (*Dicentrarchus labrax*) and Atlantic halibut (*Hippoglossus hippoglossus*) at 91–96% (Gomes da Silva and Oliva-Teles 1998; Burel *et al.* 2000; Peach 2005). Energy ADCs for the fish meals were also high (herring meal, 93% and anchovy meal, 86%) and are in the same range as those reported for the species mentioned above (88–99%). As noted previously, differences in ADC values of feed ingredients do occur frequently and are usually the result of species differences, variations in the season of harvest/catch of the raw materials and processing conditions used by various production plants. We have no control over these factors in the present study as only one sample of each feed ingredient was used. In addition, differences can occur due to procedures used by various laboratories including fecal collection method, ADC equation used and variations in the formulation of the reference diet. With regard to the fecal collection method and ADC equation used, it is well documented that procedures involving manually stripping, anal suction or dissection cause significant stress to the animal and likely result in fecal samples contaminated with non-fecal nutrients (digestive enzymes, bodily fluids, sloughed epithelial cells, etc.). Fecal samples obtained by these methods tend to underestimate ADC while methods involving settlement, siphoning or screening may overestimate ADC due to leaching losses. The method we chose to use involved the use of a settlement column like the one

used on the original Guelph system where Cho *et al.* (1982) reported no significant losses due to leaching. In addition, our modified tank design further reduced the likelihood of leaching losses by increasing fecal recovery time. Variability in ADC values is also due to the use of different equations to calculate ADC. Recently, Forster (1999) concluded that the traditional equation used to calculate ADC (Cho *et al.* 1982) is flawed and, thus, the ADC literature for fish contains values calculated by various equations. In a preliminary work, we have confirmed the use of Forster's equation for our work with cod (Tibbetts *et al.* 2006). While much of the data cited in this paper for comparison would likely have been calculated using the traditional equation, the differences are typically very small and not significant, but may partly explain some of the variation presented especially for feed ingredients of low digestibility.

### *Zooplankton and crustacean by-product meals*

Protein ADCs were high for whole krill (96%) and crab (89%) meals and low for shrimp meal (67%). Although little published information exists for krill meal digestibility in fish, a lower value (87%) has been reported for rainbow trout (Vens-Capel and Horstmann 1978 in Storebakken 1988) and is likely due to differences in product quality. Although a different product, the protein ADC of krill hydrolysate was found to be almost the same (98%) in Atlantic halibut (Peach 2005). The 2% higher protein ADC observed in halibut may be due to the lack of chitin present in krill hydrolysates, regardless, the protein ADC of whole krill meal by cod is very high. Protein ADC of crab meal measured in this study with cod (89%) is similar to that of Atlantic halibut (88%) and both are higher than reported previously in our lab with haddock (84%) (Tibbetts *et al.* 2004). This is likely the result of improved production protocols now employed by the crab meal manufacturer as mentioned earlier. The low protein ADC reported here for shrimp meal (67%) is similar to our previous report with haddock (73%) and both are lower (82%) than that reported for Atlantic halibut (Tibbetts *et al.* 2004; Peach 2005). The discrepancy between haddock/cod and other species may be due to the unusually high ash content of the shrimp meal sample used in these studies. As such, digestibility of shrimp meal by gadoids may have to be re-examined with alternate shrimp meal sources. Energy ADC was high for whole krill meal (96%), mid-range for

crab meal (82%) and low for shrimp meal (41%). The value reported for whole krill meal (96%) is consistent with that reported for krill hydrolysate (97%) by Atlantic halibut (Peach 2005). The energy ADC for crab meal in cod fully agrees with that reported for haddock (83%) but the value for shrimp meal (41%) is significantly lower than those reported for haddock and halibut at 66–75% (Tibbetts *et al.* 2004; Peach 2005).

### *Animal by-product meals*

Protein ADCs were mid-range for poultry by-product meal (80%) and low for hydrolyzed feather meal (62%). Animal by-product meals are highly variable in proximate composition based upon several factors (raw material source and freshness, production processes and storage) and, as such, the reported values for protein ADC are also highly variable in fish studies. Protein ADC values reported for poultry by-product meal for salmonids (Hajen *et al.* 1993; Sugiura *et al.* 1998; Bureau *et al.* 1999; Cheng and Hardy 2002; Cheng *et al.* 2004) and Atlantic halibut (Peach 2005) are in a wide range of 74–96%. Our value reported for cod (80%) is within this range and also consistent with that reported (80%) for gilthead seabream (*Sparus aurata*) (Lupatsch *et al.* 1997). Protein ADC of hydrolyzed feather meal is higher for salmonids at 71–87% (Hajen *et al.* 1993; Sugiura *et al.* 1998, 2000; Bureau *et al.* 1999; Cheng *et al.* 2004) than that reported here for cod (62%) but similar to that reported for Atlantic halibut (58%) (Peach 2005). The highly variable nature of animal by-product meals is also reflected in energy ADC where the values reported for the species listed above are also highly variable for poultry by-product meal (65–91%) and hydrolyzed feather meal (57–85%). Our values for poultry by-product meal (71.0%) and hydrolyzed feather meal (58.9%) are consistent with those reported for Chinook salmon at 72% and 57%, respectively (Hajen *et al.* 1993). The energy ADC of hydrolyzed feather meal is also similar to that of Atlantic halibut at 62% (Peach 2005).

### *Oilseed meals*

Protein ADC was high for soybean meal (92%), soy protein concentrate (99%) and soy protein isolate (97%). Digestibility of soybean meal has been extensively studied with various fish species and although there is a broad range reported on the protein ADC



(76–98%), the value found here for cod (92%) is consistent with those reported for rainbow trout (92%), coho salmon (93%) and haddock (92%) (Glencross *et al.* 2005; Sugiura *et al.* 1998; Tibbetts *et al.* 2004). Similarly, there is a wide range of values (61–92%) reported for energy ADC for the above species (Hajen *et al.* 1993; Lupatsch *et al.* 1997; Gomes da Silva and Oliva-Teles 1998; Morales *et al.* 1999; Lee 2002; Cheng and Hardy 2003; Peach 2005; Glencross *et al.* 2005; Tibbetts *et al.* 2004) although the value found for cod (88%) agrees with haddock (88%) (Kim *et al.* 2006). The protein ADC of soy protein concentrate for cod (99%) is consistent with those reported for rainbow trout (98%) and Atlantic halibut (100%) while the energy ADC (95%) is slightly higher than those of rainbow trout (87%) and Atlantic halibut (92%) (Glencross *et al.* 2005; Peach 2005). The protein ADC of soy protein isolate for cod (97%) is close to that reported for rainbow trout (98%) while the energy ADC (92%) is slightly lower than that of rainbow trout (96%) (Glencross *et al.* 2005). Clearly, concentrating soybean meal into concentrates/isolates has a positive effect on digestibility and may be attributed to a reduction in anti-nutritional factors associated with raw soybean meal. This has been confirmed with rainbow trout, Atlantic salmon and Atlantic halibut where no negative effects on fish growth performance were observed with diets containing relatively high levels of soy protein concentrate (Kaushik *et al.* 1995; Storebakken *et al.* 1998a, 1998b; Berge *et al.* 1999). However, given that protein and energy digestibility of soybean meal is already high for cod (92 and 88%, respectively), further processing significantly increases cost of the products and therefore may not provide any additional benefit on a price per digestible nutrient basis. The use of these ingredients in commercial cod feeds will require growth studies and a full economic evaluation in a least-cost ration formulation. Interestingly, it was recently found that, in contrast to salmon, cod do not develop enteritis when soybean meal is included at high levels in the feed, which is very promising, given the high dietary protein requirement of cod (Rosenlund and Skretting 2006).

Protein ADC was mid-range for canola meal (76%) and high for canola protein concentrate (89%). For canola meal, this value is lower than other fish species which are in the range of 83–95% (Hajen *et al.* 1993; Mwachireya *et al.* 1999; Burel *et al.* 2000; Cheng and Hardy 2002; Tibbetts *et al.* 2004; Peach 2005) but the value for canola protein

concentrate (89%) is consistent with rainbow trout (90%) reported by Thiessen *et al.* (2004). The energy ADC of canola meal for cod (61%) is in the range (52–76%) reported for salmonids and halibut (Anderson *et al.* 1992; Hajen *et al.* 1993; Mwachireya *et al.* 1999; Burel *et al.* 2000; Cheng and Hardy 2002; Peach 2005) and was similar (60%) to haddock (Tibbetts *et al.* 2004). The energy ADC for canola protein concentrate is relatively unknown for most fish species with the exception of rainbow trout (reported value of 86%, Thiessen *et al.* 2004), which is higher than the value obtained for cod (83%). Like soybean meal, further processing of canola meal to produce canola protein concentrate had a positive effect on both protein ADC (canola protein concentrate 89% > canola meal 76%) and energy ADC (canola protein concentrate 83% > canola meal 61%). However, it appears that ash is also concentrated to a relatively high level (>10%) which is roughly double that of the soy products and, hence, the digestibility of energy of canola protein concentrate is marginal. The use of canola products in cod and haddock (Tibbetts *et al.* 2004) diets agrees with those of Burel *et al.* (2000) on rainbow trout and turbot, that despite much progress in genetic engineering and processing technologies, the potential use of rapeseed and canola-derived meals at higher levels in carnivorous fish feeds may not be feasible. Protein and energy ADCs of flaxseed meal by cod were low. Although there is little data for comparison among cold-water fish species, the values are better for protein (81%) and energy (63%) for rohu (*Labeo rohita*) (Hossain *et al.* 1997), which is not surprising given the warm water preference of that species. The product used in that study was a commercial product with a higher protein and lower fiber and carbohydrate content, while the flaxseed meal we used was produced in our lab by finely grinding flaxseed press-cake after oil extraction. This product contained seed hulls which contributed high levels of indigestible fiber to the experimental diet. When incorporated at 30% of the diet, it likely increased the dietary fiber (bulk) concentration to a level that induced a laxative effect. As a result of the increased gut transition rate, a pronounced effect on fecal output was observed with the flaxseed diet. Increased dietary “bulk” content caused a significantly increased fecal egestion time in European seabass as well (Dias *et al.* 1998). Undoubtedly, this was the cause of poor digestibility of other nutrients and energy, an observation supported by Mwachireya *et al.* (1999) who found that high levels of dietary fiber had an adverse effect on nutrient digestibility.

### *Pulse meals*

Protein ADC was high for pulse meals (90% for both) and mid-range for energy ADC (pea protein concentrate, 77% and white lupin meal, 75%). The protein ADCs of the pulse meals (90%) are consistent with those reported for rainbow trout (Morales *et al.* 1999; Burel *et al.* 2000; Glencross *et al.* 2003, 2005; Thiessen *et al.* 2003). The protein ADC of pea protein concentrate is also similar to turbot (93%) but lower for white lupin meal where a higher value (98%) has been reported (Burel *et al.* 2000). The higher protein digestibility is likely due to the fact that the lupin meal used by Burel *et al.* (2000) was finely ground and then extruded, whereas, lupin meal used here was finely ground but not processed. Energy ADC of pea protein concentrate was highly variable (54–87%) for rainbow trout (Burel *et al.* 2000; Thiessen *et al.* 2003) but there is good agreement between the value for cod (77%) and that of turbot (78%) by Burel *et al.* (2000). Like pea protein concentrate, the reported energy ADC values for white lupin meal are highly variable (52–77%) for rainbow trout (Morales *et al.* 1999; Burel *et al.* 2000; Glencross *et al.* 2003, 2005) but the value for cod (75%) falls within this range. The extruded lupin meal used by Burel *et al.* (2000) also led to higher energy ADC by turbot (85%) as compared to cod (75%). There appears to be some potential for the use of pulse meals in marine fish diets, but they should be pre-extruded to increase the digestibility of non-protein components and, in the case of pea protein concentrate, should be produced by wet-milling to reduce the levels of soyasaponin 1 that may present off-flavors in the diet. In a comprehensive review of pea proteins, Owusu-Ansah and McCurdy (1991) noted that the major drawback of pea protein supplemented products was the objectionable flavor and that further investigation was needed, especially with the concentrates. Since feed intake was reduced in fish receiving the pea protein concentrate diet and it is well known that a reduction in feed intake can elevate the level of metabolic fecal nitrogen, overcoming the palatability problems may reveal the protein ADC to be even higher than reported here (90%).

### *Cereal grain meals*

Protein ADC was high for corn gluten meal (86%) and mid-range for energy ADC (83%). The reported protein ADC values for salmonids (87–97%) are slightly

higher than our value (86%) for cod (Anderson *et al.* 1992; Yamamoto *et al.* 1997, 1998; Sugiura *et al.* 1998; Morales *et al.* 1999; Cheng and Hardy 2003; Thiessen *et al.* 2004) while it was similar to those reported for other marine fish (79–93%) like haddock, seabream and Atlantic halibut (Yamamoto *et al.* 1998; Tibbetts *et al.* 2004; Peach 2005). Although there is some variation in the reported energy ADC values (76–91%) for rainbow trout (Morales *et al.* 1999; Cheng and Hardy 2003; Thiessen *et al.* 2004), our value for cod (83%) was within that range and similar to those recently reported for haddock (81%) and Atlantic halibut (85%) (Tibbetts *et al.* 2004; Peach 2005). It has been reported that corn gluten meal can effectively replace up to one-third of the fish meal in diets for turbot (Regost *et al.* 1999) and there is good potential for its use in cod diets, provided there are no adverse effects of xanthophylls present to pigment the flesh. Protein ADC was high for wheat gluten meal (100%) as was energy ADC (95%). These values are consistent with those reported for Atlantic salmon, coho salmon, rainbow trout and European seabass with protein ADC of 100–101% and energy ADC of 98% (Sugiura *et al.* 1998; Robaina *et al.* 1999; Storebakken *et al.* 2000). The use of wheat gluten meal in the diet for Atlantic salmon has proven, not only to be equal to that of fish meal, but in many cases, superior to using fish meal alone. In a comprehensive study with Atlantic salmon, Storebakken *et al.* (2000) found no differences in growth of fish fed diets containing 17% wheat gluten meal (35% of total dietary protein) compared to a diet containing fish meal as the only protein source. They showed that partial replacement of fish meal with wheat gluten meal led to increased protein, fat and energy ADCs as well as availability of amino acids (except alanine and lysine). With such high digestibility, lack of anti-nutritional factors and no offensive taste, wheat gluten meal, properly supplemented with certain amino acids, shows significant potential as a fish meal replacement in cod diets. However, like all plant protein concentrates, economics of feed production will need to be considered.

### *Test diet independency*

For digestibility data of single feed ingredients to be useful in least-cost ration formulations, it is assumed that the protein ADC or DE content of the single feed ingredient and the protein ADC or DE content of the basal mix portion of the diet are

independent of one another (Cho *et al.* 1982). If this assumption is true, then the calculated (or predicted) protein ADC or DE content of a test diet and the actual measured protein ADC or DE content of the test diet would always be the same. This assumption has been tested and validated for other species like rainbow trout, channel catfish, carp, tilapia, ayu, seabass, Australian silver perch and Australian shortfinned eel (Cho *et al.* 1982; Wilson and Poe 1985; Cho and Kaushik 1990; Watanabe *et al.* 1996a, 1996b; da Silva and Oliva-Teles 1998; Allan *et al.* 1999; Engin and Carter 2002) but yet to be validated for Atlantic cod. We compared the predicted and measured values in order to test this assumption using a wide range of test feed ingredients (Tables 5 and 6). For the protein ADC data, our results clearly show that this assumption was true for virtually all test diets, with the only exceptions being for those diets containing test ingredients of very high (>99%, wheat gluten) or very low (<67%, hydrolyzed feather and flaxseed) protein ADCs. In terms of DE, the assumption was true for all test diets without exception. The correlation between measured and predicted values was very high (Pearson correlations of 0.95 for protein ADC and 0.99 for DE). It would appear that for the rare feed ingredient where independency does not hold true, the poor digestibility of that particular ingredient would warrant its exclusion from diet formulation.

## **Conclusions**

This study has identified several highly digestible (>92% protein ADC and >85% energy ADC) feed ingredients for Atlantic cod on-growing diets, including fish meals, soy-based products, whole krill and wheat gluten meal. Other ingredients with some potential include pulse meals, crab meal, corn gluten meal and canola protein concentrate (85–90% protein ADC and 75–85% energy ADC). Due to high levels of poorly digestible components (ash, fiber, carbohydrate and keratin), poultry and feather by-products, canola, shrimp and flaxseed meals may have limited value as feed ingredients for Atlantic cod diets.

## **Acknowledgements**

Assistance by Audrey Butt and Ryan Gibbs with sample preparation and analyses, Laura Garrison with fish husbandry and Glen Farrell for the schematic of the digestibility system is gratefully appreciated. We thank the following companies for their generous donation of test feed ingredients: St. Laurent Gulf Products Ltd., Caraquet, NB, Shur-Gain Feeds, Truro, NS, Skretting Canada, Vancouver, BC, MCN BioProducts Inc., Saskatoon, SK and Bioriginal Food and Science Corp., Saskatoon, SK. The critical review and valuable suggestions of Drs. Harry Murray and John van der Meer are greatly appreciated.

**Table 1** Formulation and proximate composition of the basal diet (*as-fed* basis)

Ingredient	g/kg
Herring meal (76.9% CP) <sup>a</sup>	480.0
Wheat gluten meal (80.1% CP) <sup>b</sup>	50.0
CPSP-G (73.2% CP) <sup>c</sup>	50.0
Wheat middlings (17.9% CP) <sup>d</sup>	168.0
Whey powder (10.4% CP) <sup>e</sup>	70.0
Krill hydrolysate (57.7% CP) <sup>f</sup>	20.0
Corn starch (pre-gel) <sup>g</sup>	56.0
Vitamin mixture <sup>h</sup>	19.5
Mineral mixture <sup>h</sup>	19.5
Choline chloride <sup>i</sup>	3.0
Herring oil <sup>j</sup>	64.0
<i>Proximate composition (n=2)</i>	
Moisture (g/kg)	100.5
Crude protein (g/kg)	487.5
Lipid (g/kg)	120.6
Ash (g/kg)	63.1
Carbohydrate <sup>k</sup> (g/kg)	228.3
Gross energy (MJ/kg)	20.5

<sup>a</sup> St. Laurent Gulf Products Limited (Caraquet, NB, Canada).

<sup>b</sup> Roquette UK Limited (Northants, UK).

<sup>c</sup> Concentre proteique soluble de poisson (soluble fish protein concentrate) (Sopropêche, France).

<sup>d</sup> Dover Mills Limited (Halifax, NS, Canada).

<sup>e</sup> Farmers Co-operative Dairy (Truro, NS, Canada).

<sup>f</sup> SD-KH2, MaraVision Marine Products (Vancouver, BC, Canada).

<sup>g</sup> National Starch and Chemical Company (Bridgewater, NJ, USA).

<sup>h</sup> Vitamin and mineral premixes according to Tibbetts *et al.* (2004).

<sup>i</sup> USB Corporation (Cleveland, OH, USA).

<sup>j</sup> Corey Feed Mills Limited (Fredericton, NB, Canada).

<sup>k</sup> Calculated as 1000 – (moisture + crude protein + lipid + ash).

**Table 2** Proximate composition and gross energy content (*as-fed* basis) of the test feed ingredients (n=2)

	International feed number	Moisture (g/kg)	Crude protein (g/kg)	Lipid (g/kg)	Ash (g/kg)	Carbohydrate <sup>a</sup> (g/kg)	Gross energy (MJ/kg)
<i>Fish meals</i>							
Herring meal <sup>b</sup>	5-02-000	70.8	745.4	101.3	104.4	0.0	20.8
Anchovy meal <sup>c</sup>	5-01-985	77.8	683.2	95.8	157.6	0.0	19.1
<i>Zooplankton and crustacean by-product meals</i>							
Whole krill meal <sup>d</sup>	5-16-423	47.7	723.9	52.9	175.5	0.0	18.8
Crab meal <sup>e</sup>	5-01-663	91.3	540.4	57.1	227.3	83.9	15.8
Shrimp meal <sup>f</sup>	5-04-226	62.3	372.3	34.8	383.8	146.8	12.4
<i>Animal by-product meals</i>							
Poultry by-product meal <sup>g</sup>	5-03-798	50.2	663.4	145.7	107.6	33.1	22.0
Hydrolyzed feather meal <sup>g</sup>	5-03-795	58.0	835.0	79.4	38.1	0.0	22.7
<i>Oilseed meals</i>							
Soybean meal <sup>h</sup>	5-04-612	113.7	473.1	20.4	59.8	333.0	17.4
Soy protein concentrate <sup>i</sup>	5-08-038	79.0	686.6	3.1	51.1	180.2	19.0
Soy protein isolate <sup>i</sup>	–	76.4	855.7	44.0	44.7	0.0	21.2
Canola meal <sup>j</sup>	5-06-145	63.1	389.1	26.5	71.0	450.3	18.2
Canola protein concentrate <sup>j</sup>	–	47.5	614.5	27.3	103.5	207.2	19.4
Flaxseed meal <sup>k</sup>	–	120.5	309.9	95.1	46.3	428.2	18.8



**Table 2 (continued)** Proximate composition and gross energy content (*as-fed* basis) of the test feed ingredients (n=2)

	International feed number	Moisture (g/kg)	Crude protein (g/kg)	Lipid (g/kg)	Ash (g/kg)	Carbohydrate <sup>a</sup> (g/kg)	Gross energy (MJ/kg)
<i>Pulse meals</i>							
Pea protein concentrate <sup>l</sup>	–	72.1	489.8	40.7	49.0	348.4	18.5
White lupin meal <sup>m</sup>	–	74.5	384.9	62.1	34.2	444.3	18.9
<i>Cereal grain meals</i>							
Corn gluten meal <sup>h</sup>	5-28-242	110.1	616.2	42.6	9.9	221.2	20.9
Wheat gluten meal <sup>n</sup>	–	73.9	793.1	19.0	5.0	109.0	22.6

<sup>a</sup> Calculated as 1000 – (moisture + crude protein + lipid + ash).

<sup>b</sup> Scotia Garden Seafood Incorporated (Yarmouth, NS, Canada).

<sup>c</sup> Sindicato SA, Grupo Sipesa (Lima, Peru).

<sup>d</sup> Aqion (Colorado Springs, CO, USA).

<sup>e</sup> St. Laurent Gulf Products Limited (Caraquet, NB, Canada).

<sup>f</sup> Island Fisherman's Co-Op (Lemeque, NB, Canada).

<sup>g</sup> Rothsay (Dundas, ON, Canada).

<sup>h</sup> Bunge Canada (Oakville, ON, Canada).

<sup>i</sup> Soycomil<sup>®</sup> and Pro-Fam<sup>®</sup>, respectively; Archer Daniels Midland (Decatur, IL, USA).

<sup>j</sup> MCN BioProducts Incorporated (Saskatoon, SK, Canada).

<sup>k</sup> Bioriginal Food and Science Corporation (Saskatoon, SK, Canada).

<sup>l</sup> Parrheim Foods (Portage La Prairie, MB, Canada).

<sup>m</sup> Alberta Department of Agriculture (AB, Canada).

<sup>n</sup> Roquette UK Limited (Northants, UK).

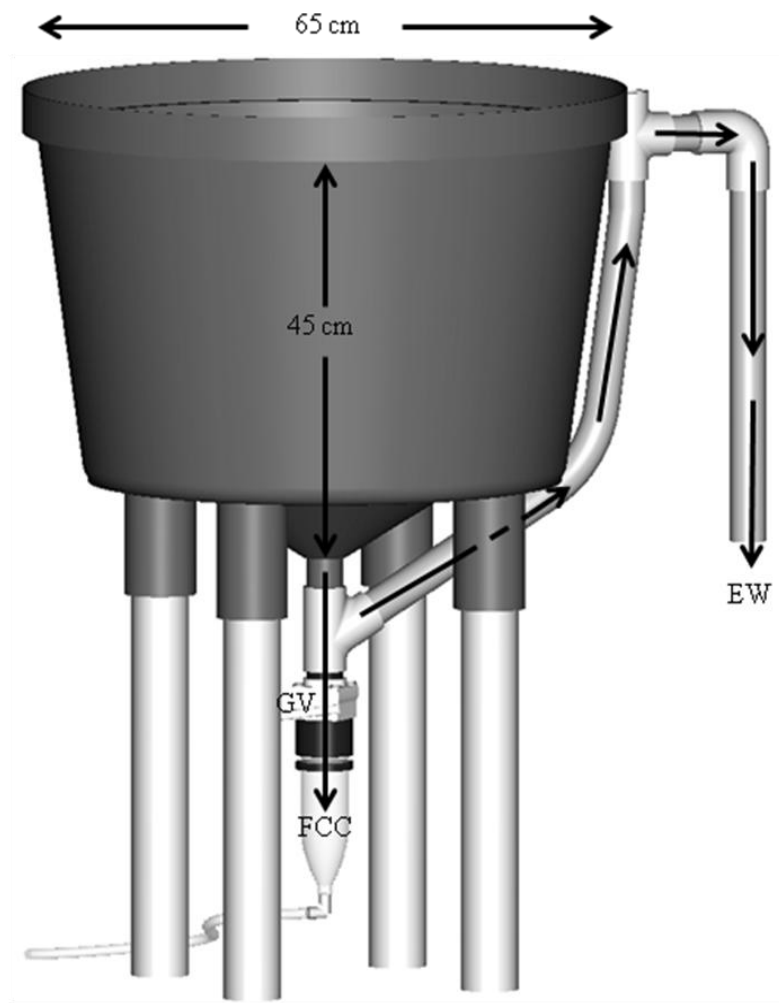

**Figure 1** Modified digestibility system used in this study (GV = gate valve; FCC = fecal collection column; EW = effluent water).

**Table 3** Proximate composition, gross energy content (*as-fed* basis, n=2) and diet digestibility (mean  $\pm$  SE, n=4, ranked highest to lowest) of the reference and test diets

	Moisture (g/kg)	Crude protein (g/kg)	Ash (g/kg)	Gross energy (MJ/kg)	Diet ADC (%)
Wheat gluten meal	90.7	595.3	50.1	21.1	81.1 $\pm$ 0.5
Whole krill meal	89.3	560.8	98.4	20.0	80.2 $\pm$ 0.4
Soy protein isolate	94.2	611.2	63.9	20.6	79.8 $\pm$ 1.1
Herring meal	91.7	570.9	80.4	20.5	79.0 $\pm$ 0.1
Soy protein concentrate	91.1	559.6	65.3	20.0	77.4 $\pm$ 0.4
Anchovy meal	94.4	566.9	95.2	19.8	77.3 $\pm$ 0.6
Corn gluten meal	100.2	535.6	53.1	20.5	77.0 $\pm$ 0.4
Reference	100.1	493.9	69.7	20.4	76.0 $\pm$ 0.7
Soybean meal	100.4	483.7	68.5	19.6	75.5 $\pm$ 0.6
Canola protein concentrate	83.5	542.2	80.8	20.0	74.9 $\pm$ 0.4
Crab meal	94.8	507.8	109.3	19.2	74.5 $\pm$ 0.2
Poultry byproduct meal	81.8	548.5	82.9	20.8	73.3 $\pm$ 1.2
Pea protein concentrate	87.9	495.1	65.9	19.9	72.7 $\pm$ 0.3
White lupin meal	89.6	456.0	60.1	20.0	70.8 $\pm$ 0.6
Hydrolyzed feather meal	83.0	599.3	60.4	21.1	68.4 $\pm$ 0.7
Canola meal	88.4	468.6	70.7	19.8	66.8 $\pm$ 0.6
Shrimp meal	85.4	463.3	154.1	18.2	60.9 $\pm$ 0.5
Flaxseed meal (period 2)	102.7	439.5	63.2	19.9	58.8 $\pm$ 0.1
Flaxseed meal (period 1)					52.7 $\pm$ 0.3

**Table 4** Apparent digestibility coefficients (%) for protein and energy and the DE content (MJ/kg) of 17 common and alternate test feed ingredients and the reference diet for Atlantic cod

Ingredient	Protein ADC	Energy ADC	DE <sup>a</sup>
Reference diet	91.2	80.7	16.5
<i>Fish meals</i>			
Herring meal	93.3±0.6	92.8±0.1	19.3±0.0
Anchovy meal	92.2±0.5	86.4±0.7	16.5±0.1
<i>Zooplankton and crustacean by-product meals</i>			
Whole krill meal	96.3±0.6	96.3±0.6	18.1±0.1
Crab meal	89.4±0.7	82.4±0.7	13.0±0.1
Shrimp meal	66.7±1.4	41.4±4.0	5.1±0.5
<i>Animal by-product meals</i>			
Poultry by-product meal	80.2±0.7	71.0±1.1	15.6±0.2
Hydrolyzed feather meal	62.4±0.3	58.9±0.3	13.3±0.1
<i>Oilseed meals</i>			
Soybean meal	92.3±1.5	88.1±0.3	15.3±0.1
Soy protein concentrate	98.6±0.6	94.9±0.3	18.0±0.1
Soy protein isolate	97.4±0.6	92.1±0.8	19.5±0.2
Canola meal	76.0±1.6	60.6±1.7	11.0±0.3
Canola protein concentrate	88.8±0.4	83.3±0.3	16.1±0.1
Flaxseed meal (period 1)	50.2±1.6	21.2±0.3	4.0±0.1
Flaxseed meal (period 2)	55.0±1.1	37.4±0.1	7.0±0.0
<i>Pulse meals</i>			
Pea protein concentrate	89.8±0.8	76.7±0.3	14.2±0.1
White lupin meal	89.7±3.8	75.3±1.3	14.3±0.2
<i>Cereal grain meals</i>			
Corn gluten meal	86.3±1.0	82.7±0.7	17.2±0.1
Wheat gluten meal	99.9±0.3	95.4±0.7	21.5±0.2

Values are mean ± SE (n=4 except for flaxseed meal where n=2).

<sup>a</sup> As-fed basis.

**Table 5** Apparent digestibility coefficients (ADC) for protein of the test diets—comparison of measured vs. predicted values for determination of independency

Test diet	Diet protein ADC		P-value
	Measured	Predicted	
<i>Fish meal diets</i>			
Herring meal	92.0±0.2	91.8±0.2	0.55
Anchovy meal	91.6±0.2	91.5±0.2	0.79
<i>Zooplankton and crustacean by-product meal diets</i>			
Whole krill meal	93.2±0.2	92.7±0.2	0.20
Crab meal	90.6±0.2	90.7±0.2	0.90
Shrimp meal	85.2±0.3	83.9±0.4	0.05
<i>Animal by-product meal diets</i>			
Poultry by-product meal	87.8±0.7	88.4±0.6	0.51
Hydrolyzed feather meal	78.2±0.8 <sup>a</sup>	82.0±0.6 <sup>b</sup>	0.01
<i>Oilseed meal diets</i>			
Soybean meal	91.5±0.4	91.5±0.4	0.99
Soy protein concentrate	94.0±0.2	93.4±0.2	0.08
Soy protein isolate	92.8±1.1	92.3±0.8	0.74
Canola meal	87.3±0.4	86.6±0.5	0.32
Canola protein concentrate	89.9±0.5	90.1±0.4	0.77
Flaxseed meal (period 1)	79.7±1.7 <sup>a</sup>	75.1±2.4 <sup>b</sup>	0.03
Flaxseed meal (period 2)	83.5±0.2 <sup>a</sup>	80.4±0.3 <sup>b</sup>	0.02
<i>Pulse meal diets</i>			
Pea protein concentrate	90.3±0.6	90.3±0.6	1.00
White lupin meal	90.8±1.0	90.8±1.1	0.96
<i>Cereal grain meal diets</i>			
Corn gluten meal	89.5±0.4	89.8±0.3	0.62
Wheat gluten meal	94.8±0.1 <sup>a</sup>	93.8±0.1 <sup>b</sup>	0.00

Values are mean ± SE (n=4 except for flaxseed meal where n=2); values within same row having different superscript letters are significantly different (P<0.05).

**Table 6** Digestible energy (DE) content of the test diets — comparison of measured vs. predicted values for determination of independency

Test diet	Diet DE		P-value
	Measured	Predicted	
<i>Fish meals</i>			
Herring meal	19.0±0.0	19.0±0.0	0.34
Anchovy meal	18.1±0.1	18.2±0.0	0.79
<i>Zooplankton and crustacean by-product meals</i>			
Whole krill meal	18.6±0.1	18.5±0.0	0.28
Crab meal	17.2±0.0	17.1±0.0	0.38
Shrimp meal	14.5±0.2	14.4±0.2	0.88
<i>Animal by-product meals</i>			
Poultry by-product meal	17.8±0.2	17.7±0.1	0.63
Hydrolyzed feather meal	16.8±0.1	17.0±0.0	0.21
<i>Oilseed meals</i>			
Soybean meal	17.8±0.1	18.0±0.0	0.20
Soy protein concentrate	18.6±0.0	18.7±0.0	0.63
Soy protein isolate	19.2±0.2	19.1±0.1	0.80
Canola meal	16.3±0.1	16.3±0.1	0.89
Canola protein concentrate	17.7±0.1	17.9±0.0	0.13
Flaxseed meal (period 1)	14.2±0.0	14.1±0.0	0.74
Flaxseed meal (period 2)	15.2±0.0	15.2±0.0	0.21
<i>Pulse meals</i>			
Pea protein concentrate	17.3±0.1	17.4±0.0	0.34
White lupin meal	17.3±0.1	17.4±0.1	0.42
<i>Cereal grain meals</i>			
Corn gluten meal	18.6±0.1	18.6±0.0	0.74
Wheat gluten meal	19.9±0.1	19.8±0.1	0.33

Values are mean ± SE (n=4 except for flaxseed meal where n=2).

# Chapter 4

## **Effects of dietary protein and lipid levels and DP/DE ratio on growth, feed utilization and hepatosomatic index of juvenile haddock, *Melanogrammus aeglefinus* L.**

*This chapter was published as:*

Tibbetts, S.M., Lall, S.P., Milley, J.E. (2005) Effects of dietary protein and lipid levels and DP DE<sup>-1</sup> ratio on growth, feed utilization and hepatosomatic index of juvenile haddock, *Melanogrammus aeglefinus* L. *Aquaculture Nutrition* 11, 67-75.

## Abstract

Juvenile haddock, *Melanogrammus aeglefinus* L. (initial weight,  $13.5 \pm 0.1$  g) were fed practical diets containing digestible protein to digestible energy (DP/DE) ratios of 25–30 g DP/MJ DE *as-fed* using three protein levels (450, 500 and 550 g/kg) each at two lipid levels (110 and 160 g/kg) for 63 days. The results showed mean weight gain and feed conversion ratio were highest for diets containing 28.5 and 30.2 g DP/MJ DE. DP/DE ratio had no significant effect on protein efficiency ratio except at the lowest level (24.7 g DP/MJ DE) indicating a protein sparing effect of higher lipid when dietary protein is below the requirement. Haddock appears to preferentially use protein as the prime source of DE. DP/DE ratio had little effect on apparent digestibility (AD) of protein while AD of lipid was significantly affected. Significant differences in AD of energy and organic matter were found to be inversely related to the carbohydrate level of the diet. DP/DE ratios of 28.5 g DP/MJ DE or lower resulted in significantly higher hepatosomatic indexes. The highest whole-body nitrogen gains and energy retention efficiencies were achieved at 28.5 and 30.2 g DP/MJ DE, whereas only slight differences in nitrogen retention efficiencies were observed. The highest levels of energy retained in the form of protein were achieved at 28.5 and 30.2 g DP/MJ DE. The diet that provided the best growth, feed utilization and digestibility with minimal HSI contained 546 g/kg protein (513 g/kg DP), 114 g/kg lipid, 164 g/kg carbohydrate, 17.0 MJ/kg DE and a DP/DE ratio of 30.2 g DP/MJ DE.

## Introduction

Haddock aquaculture is a relatively new industry in Atlantic Canada and Europe and information on nutrient utilization and dietary requirements are limited (Lall *et al.* 2003). Initial studies with haddock show a protein requirement of 500–540 g/kg on a dry matter basis for juveniles (Kim and Lall 2001; Kim *et al.* 2001), a phosphorous requirement of 9.6 g/kg on an *as-fed* basis (Roy and Lall 2003) and that haddock efficiently utilize nutrients from common feed ingredients available in Atlantic Canada (fish meals, plant protein supplements, crustacean by-product meals) (Tibbetts *et al.* 2004). Unlike salmonids, gadoids like haddock store the major proportion of dietary lipid as triacylglycerol in the liver with the lipid content of the muscle tissue rarely



exceeding 10 g/kg (Nanton *et al.* 2001). A direct linear relationship between lipid consumption and liver size (HSI) has been demonstrated in gadoid fishes like Atlantic cod (*Gadus morhua*) (Lie *et al.* 1988; Jobling *et al.* 1991; Morais *et al.* 2001) and the same has been observed in haddock when fed high amounts of dietary lipid (>120 g/kg *as-fed* basis) (Nanton *et al.* 2001, 2003). Lie *et al.* (1988) has suggested that a reduced feeding frequency (feeding *ad libitum* every third day versus every day) can reduce liver indexes in Atlantic cod through a reduction in overall fat intake, however, growth rate is significantly compromised. Both protein and lipid are highly available sources of energy for fish (National Research Council 1993), however, DE content of carbohydrate may vary among fish species (Wilson 1994). The use of protein as a dietary source of energy is undesirable because of the high cost of protein relative to the cost of non-protein energy (Watanabe 2002). A proper balance of digestible protein (DP) and digestible energy (DE) (DP/DE ratio) is necessary to maintain high growth rates and good feed conversion efficiency (Lee and Putnam 1973), improve protein utilization and minimize excessive accumulation of lipid and glycogen in the somatic tissues and liver (Cho and Kaushik 1985, 1990) and minimize undesirable nitrogenous waste output and improve the quality of fish farm effluents. While the estimated optimum DP/DE ratio for coldwater rainbow trout, *Oncorhynchus mykiss*, and Atlantic salmon, *Salmo salar*, reared in freshwater is 20–24 g DP/MJ DE (Cowey 1992; Storebakken 2002), DP/DE ratio for large salmon (>2.5 kg) decreases to 16–17 g DP/MJ DE. Information on protein and energy utilization for most coldwater marine fishes is limited. Studies conducted on gilthead seabream, *Sparus aurata* L., a warm water marine fish, show that optimum DP/DE ratio changes with fish size, growth and feed intake (FI) (Lupatsch *et al.* 2001). It appears that haddock diets must be low in lipid (<140 g/kg, DM-basis) and available carbohydrate (<14 g/kg, DM-basis) to prevent excessive lipid and glycogen deposition in the liver (Lall *et al.* 2003). Our initial studies (Kim and Lall 2001; Kim *et al.* 2001) were designed to determine the dietary protein requirement of fish fed isoenergetic diets (~16.6 MJ DE/kg). The primary objective of this study was to examine the effects of feeding juvenile haddock with diets containing various combinations of dietary protein and non-protein energy on growth performance, feed conversion efficiency, HSI, diet digestibility

and nutrient retention efficiency to find the optimum dietary DP/DE ratio for on-growing fish.

## **Materials and methods**

### *Rearing systems and experimental design*

Haddock juveniles (mean initial weight,  $13.5 \pm 0.1$  g) hatched and reared at the NRCC Institute for Marine Biosciences, Marine Research Station (Halifax, Nova Scotia) were used in this study. Seven hundred and twenty fish were randomly distributed into 18 cylindrical fibreglass tanks (350 L capacity) at 40 fish per tank and acclimated to the tanks for 10 days prior to the trial. During the acclimation period, the fish were fed Zeigler™ Haddock Ration (Zeigler Bros, Inc., Gardners, PA, USA) twice daily (0900 and 1600 h). The proximate composition (*as-fed* basis) of this diet was: crude protein 520 g/kg, lipid 160 g/kg, nitrogen-free extract 95 g/kg, gross energy 23 MJ/kg, moisture 90 g/kg, ash 110 g/kg and fibre 25 g/kg. The DP and DE of this diet were measured using fish weighing 94 g in the same manner as described by Tibbetts *et al.* (2004) and were 480 g/kg and 20 MJ/kg, respectively. The experiment was conducted as a  $3 \times 2$  factorial design (three protein levels  $\times$  two lipid levels) and each of six experimental diets was fed to three replicate tanks (initial biomass density,  $2 \text{ kg/m}^3$ ). Filtered ( $60 \mu\text{m}$ ), UV-treated sea water (salinity, 28–30 g/L) was supplied to each tank at a flow-rate of 4 L/min in a flow-through system. The water was continuously aerated in each tank (11 mg/L dissolved oxygen) and maintained thermostatically at 12°C. The rearing temperature of 12°C was selected because it is within the preferendum zone of 9–17°C for Atlantic cod where gastric evacuation rate, appetite and feeding metabolic rates are maximized (Bøhle 1974; Jobling 1988). Photoperiod was controlled automatically (12-h light : 12-h dark) with a light intensity at the water surface of 60 lux. During the feeding trial, fish were hand-fed three times daily during the week (0900, 1300, 1600 h) and twice daily on weekends (0900, 1300 h) to apparent satiation to avoid any uneaten feed. Weekly FI per individual tank was recorded by weighing feed containers at the beginning of each week and ensuring that all feed offered during the week was consumed by the fish. Any dead or moribund fish were collected, weighed and recorded on a daily basis. Fish from each tank were batch weighed and counted on days 0, 21, 42 and 63 after a 24 h fast and the

mean weight (MW) was calculated. Specific growth rate (SGR) was calculated using the equation of Ricker (1979). Feed conversion ratio (FCR) was calculated from weight of feed consumed (grams of apparent dry matter FI) divided by wet weight gain (g). Protein efficiency ratio (PER) was calculated from the wet weight gain (g) divided by the weight of protein intake (grams of apparent protein intake). At the beginning of the trial, 10 fish were randomly sampled after 24 h food deprivation and killed with an overdose of tricaine methanesulphonate (TMS). At the end of the trial, four fish from each tank (72 in total) were randomly sampled in the same manner. These fish were weighed, the liver removed and weighed (for calculation of HSI), the liver put back with the carcass, frozen on dry ice and stored at -80°C until further analyzes.

### *Experimental diets*

Six experimental diets (Table 1) were formulated to contain DP/DE ratios in the range of 25–30 g DP/MJ DE *as-fed* using three protein levels (450, 500 and 550 g/kg) each at two lipid levels (110 and 160 g/kg). Diets were formulated according to DP and DE values of common feed ingredients for juvenile haddock (Tibbetts *et al.* 2004). Dry ingredients were finely ground (<500 µm) in a Fitz mill (Fitzpatrick Co., Elmhurst, IL, USA) before being combined with the wet ingredients (choline chloride and herring oil). Micronutrients (vitamins and minerals) were pre-mixed with ground wheat as a base, using a twin-shell blender (Paterson-Kelly, East Stroudsburg, PA, USA) prior to being added to the main ingredient mixture. All ingredients were mixed in a Hobart mixer (Model H600T; Rapids Machinery Co., Troy, OH, USA) and steam-pelleted into 2.5 and 3.0 mm pellets (California Pellet Mill Co., San Francisco, CA, USA). The pellets were dried in an air-convection drier at 30°C to form dry, sinking pellets and stored in air-tight containers at -20°C until use. Diets were screened to remove fines prior to feeding. For determination of nutrient digestibility, the same diets were supplemented with chromic oxide (Cr<sub>2</sub>O<sub>3</sub>, 5 g/kg) and steam-pelleted into 4.0 mm pellets.

### *Nutrient digestibility*

To measure the apparent digestibility (AD) of organic matter, protein, energy and lipid of the experimental diets used during the growth study, a second experiment was

performed using 12 specially designed tanks. These were cylindro-conical fibreglass tanks (100 L capacity), each equipped with a faecal collection column similar to the Guelph system (Cho *et al.* 1982) and those used by Hajen *et al.* (1993). The measurements were made using 156 haddock with a mean initial weight of  $105.2 \pm 2.1$  g and a biomass density in each tank of approximately  $14 \text{ kg/m}^3$ . The collection period lasted until 30 g of wet faecal material was collected from each tank (33 days). The fish were acclimated to the tanks and experimental diets for 10 days prior to the trial. The experiment was conducted according to a randomized block design and replicated twice. Each of the six experimental digestibility diets was fed to two tanks, each containing 13 fish. Filtered ( $60 \mu\text{m}$ ), UV-treated sea water (salinity, 28–30 g/L) was supplied to each tank at a flow rate of 2 L/min in a flow-through system and continuously aerated to maintain dissolved oxygen levels (10 mg/L). Water temperature was maintained thermostatically ( $12^\circ\text{C}$ ) and monitored daily. During the experimental period, fish were hand-fed to apparent satiety three times daily during the week (0900, 1300, 1600 h) and twice daily on weekends (0900, 1300 h). All mortalities were collected, weighed and recorded on a daily basis. Each week-day, after the final feeding (1600 h), the tanks and faecal collection columns were thoroughly cleaned with a brush to remove any residual particulate matter (faeces and uneaten feed). There were no faecal collections made on weekends. Faecal samples were collected each morning (0830 h) into 250 mL plastic bottles, centrifuged ( $2750 \times g$  for 35 min at  $5^\circ\text{C}$ ) and the supernatant discarded. The faecal samples were stored in a sealed container at  $-20^\circ\text{C}$  for the duration of the collection period. Faecal samples were then lyophilized, finely ground and kept frozen at  $-20^\circ\text{C}$  until further analyzes.

### *Analytical techniques*

In preparation for analyzes, the frozen fish carcasses (including all viscera and liver) were lyophilized and finely ground. These samples were stored in air-tight containers at  $-80^\circ\text{C}$  until analysis. Lyophilized fish carcasses, diets and faecal samples were analysed using the same procedures. Moisture was determined by weight loss after drying for 24 h at  $105^\circ\text{C}$ , ash by incineration in a muffle furnace at  $550^\circ\text{C}$  for 24 h, crude protein (% nitrogen  $\times 6.25$ ) by the Dumas method (Ebeling 1968) using a Leco nitrogen

determinator (model FP-228; Leco Corporation, St Joseph, MI, USA), gross energy by a Parr Adiabatic oxygen bomb calorimeter (model 1241; Parr Instrument Company, Moline, IL, USA), total lipid by ether extraction (Tecator Soxtec System HT2 1045 extraction unit, Hoeganaes, Sweden) following acid (4 N HCl) hydrolysis (Tecator Soxtec System 1047 hydrolysis unit) and chromic oxide content of digestibility diets and faeces was measured by spectrophotometric micro-method outlined by Suzuki and Early (1991).

### *Statistical procedures*

Statistical analysis was performed according to Steel and Torrie (1960) using analysis of variance (ANOVA) in accordance with a  $3 \times 2$  factorial design to test the influence of the main effects (dietary protein and lipid levels) and the interaction between the two main effects (protein  $\times$  lipid). Treatment means were differentiated using a posteriorly hypothesis testing with specified contrasts (SYSTAT v. 8.0). All data reported as a percentage, was arcsine transformed prior to ANOVA and a 5% level of probability ( $P < 0.05$ ) was chosen in advance to sufficiently demonstrate a statistically significant difference. All correlations made between response variables were calculated in SYSTAT by simple Pearson correlation matrix (SYSTAT v. 8.0). Estimation of the DE requirement for maintenance (DE<sub>m</sub>) of juvenile haddock was determined by linear regression analysis of DE retention and DE intake using Microsoft Excel.

## **Results and discussion**

### *Survival, growth and feed efficiency*

Proximate analyses of the experimental diets confirmed that the intended protein levels (450, 500, 550 g/kg), lipid levels (110, 160 g/kg) and DP/DE ratios (25, 26, 27, 28, 29, 30 g DP/MJ DE) were achieved (Table 1). These DP/DE values fall within the range (22–33 g DP/MJ DE) reported to promote high protein gains in other juvenile fish species like rainbow trout, Atlantic halibut (*Hippoglossus hippoglossus*), Atlantic cod and gilthead seabream (Lie *et al.* 1988; Cowey 1992; Aksnes *et al.* 1996; Lupatsch *et al.* 2001). After 63 days of feeding, fish receiving all experimental diets had achieved over 400% (401–470%) growth and survival of the fish throughout the growth trial was high

(98–100%). All diets were accepted equally well by the fish as there were no significant differences in FI among experimental diets (Table 2). Final mean weight gain (Table 2) of fish fed diets containing 28.5, 29.3 and 30.2 g DP/MJ DE were significantly higher than diets containing 24.7, 26.7 and 27.5 g DP/MJ DE. Weight gain was regulated solely by increasing dietary protein level linearly and it was independent of dietary lipid level or DP/DE ratio. Similarly, SGR of fish fed diets containing 28.5, 29.3 and 30.2 g DP/MJ DE were significantly higher than all other diets. The average SGR obtained for haddock in this study (2.34%/day) is the same as those reported for juvenile European sea bass, *Dicentrarchus labrax* (2.3%/day) of similar size (Peres and Oliva-Teles 1999).

Like weight gain, FCR in this experiment was solely affected by protein content of the diet rather than lipid level or DP/DE ratio as FCR significantly improved with increasing protein level but lipid level within each protein level had no significant effect. FCR improved linearly with increasing dietary protein level ( $y = -0.0089x + 1.179$ ,  $R^2 = 0.76$ ,  $n = 18$ ,  $P < 0.05$ ). This indicates that the best FCR was achieved at the highest protein level (550 g/kg) but the additional 50 g/kg lipid was not beneficial. Unlike haddock, feed efficiency of juvenile sablefish, *Anoplopoma fimbria*, was significantly improved by higher levels of both protein and lipid (Clarke *et al.* 2000). This difference is likely due to haddock's lower tolerance for dietary lipid. The range of FCR data in this study (0.7–0.8 g feed per g gain) is consistent with previous reports with juvenile haddock (0.6–0.9 g feed per g gain) (Kim and Lall 2001; Kim *et al.* 2001; Nanton *et al.* 2001, 2003; Roy and Lall 2003), Atlantic cod (0.7 g feed per g gain) (Morais *et al.* 2001) and European sea bass (0.6–0.9 g feed per g gain) (Peres and Oliva-Teles 1999). Since protein efficiency is generally regulated by the non-protein energy input of the diet, PER is a good measure of the 'protein-sparing effect' of lipid and/or carbohydrate (Lie *et al.* 1988). By the end of the 63-day feeding trial, there were no significant differences in PER between the experimental diets with the exception of the lowest DP/DE ratio (24.7 g DP/MJ DE) which was significantly higher than all other diets. Therefore, at the higher protein levels (500 and 550 g/kg), the 50 g/kg additional lipid had no effect on PER and thus provided no protein sparing effect but it had a significant effect on PER at the lower protein level (450 g/kg). The apparent protein sparing effect of higher lipid within the 450 g/kg protein level (450/110 versus 450/160) translated into significantly higher final

weight gain, SGR, lipid gain and energy retention efficiency. This indicates that when dietary protein is adequate, haddock preferentially use protein as the prime dietary energy source, which is also the case for Atlantic cod (Lie *et al.* 1988). However, when dietary protein is limited (i.e. below requirement), dietary lipid has the ability to spare protein in haddock diets. This is also the case for European sea bass where the beneficial effects of protein sparing occurred only with a low protein diet (400 g/kg) and not with a higher protein diet (500 g/kg) (Dias *et al.* 1998). Likewise, in Atlantic cod, the beneficial effects of protein sparing has been reported in lower protein diet (480 g/kg) and not at a higher protein level (580 g/kg) (Morais *et al.* 2001). The PER values obtained in this experiment (2.5–2.8 g gain/g protein intake) are similar to previous reports on haddock (Kim and Lall 2001) and Atlantic cod studies (average, 2.3 g gain/g protein intake) of Lie *et al.* (1988).

### *Nutrient digestibility*

Although small (<2.5%) differences were found with respect to AD of protein, it was consistently high (average, 92.7%) across all dietary treatment (Table 3). These values are similar to those reported for Atlantic cod (91.2%) (Jobling *et al.* 1991) and rockfish, *Sebastes schegeli* (91.8%) (Lee *et al.* 2002) fed similar diets. Although the carbohydrate content of the diets varied from 117 to 278 g/kg, increasing carbohydrate content had only a slight effect on protein AD, which is in agreement with reports on Atlantic halibut (Grisdale-Helland and Helland 1998), Atlantic cod (Hemre *et al.* 1989), Atlantic salmon (Aksnes 1995; Hemre *et al.* 1995; Grisdale-Helland and Helland 1997) and European sea bass (Peres and Oliva-Teles 1999). Differences were observed in lipid AD where diets containing 24.7, 27.5 and 29.3 g DP/MJ DE were significantly lower than diets containing 26.7, 28.5 and 30.2 g DP/MJ DE. Results of the ANOVA indicated the effect was from protein ( $P = 0.000$ ) and not from lipid ( $P = 0.176$ ), which is consistent with Takeuchi *et al.* (1978) who reported AD of lipid in rainbow trout diets was independent of dietary lipid level. Thus, varying the dietary protein and non-protein energy levels has little effect on protein AD but has a strong effect on lipid AD for haddock which is also the case for Atlantic halibut (Berge and Storebakken 1991). Energy and organic matter AD were low for the diet containing the lowest levels of

protein and lipid (450/110) (27.5 g DP/MJ DE) but increased significantly for the diet with the highest levels of protein and lipid (550/160) (28.5 g DP/MJ DE). Since the energy content of the diet is supplied by protein, lipid and carbohydrate and differences in protein AD were negligible while there were large differences in lipid AD, the significant differences in energy AD is attributed to either lipid or carbohydrate content, or a combination of both. In the experimental diets, with a decrease in protein from 550 to 450 g/kg and lipid from 160 to 110 g/kg, the dietary carbohydrate content increases from 117 to 278 g/kg. It is well known that increasing dietary carbohydrate in carnivorous fish diets has a negative impact on diet digestibility (Sullivan and Reigh 1995; McGoogan and Reigh 1996; Sugiura *et al.* 1998). In this study, energy and organic matter AD were inversely correlated to increasing dietary carbohydrate content (Pearson correlation coefficients of -0.90 for energy and -0.92 for organic matter). The linear relationship between increasing dietary carbohydrate level and declining organic matter and energy AD is characterized by the following linear relationships: organic matter ( $y = -0.6969x + 90.192$ ,  $R^2 = 0.86$ ,  $n = 24$ ,  $P < 0.05$ ) and energy ( $y = -0.5318x + 93.018$ ,  $R^2 = 0.80$ ,  $n = 24$ ,  $P < 0.05$ ). Grisdale-Helland and Helland (1998) reported in Atlantic halibut a 7–10% reduction in organic matter AD at the highest level of carbohydrate. This is consistent with our findings with haddock where we observed a 7.1–10.7% reduction in organic matter AD at the highest dietary level of carbohydrate. Lie *et al.* (1988) suggested that carbohydrate should not exceed 170 g/kg of the diet for Atlantic cod and we confirm that organic matter and energy AD are significantly reduced for haddock in all diets containing high levels of carbohydrate (>170 g/kg).

#### *Hepatosomatic index, nutrient retention & maintenance energy requirement*

Over the course of the 63-day feeding trial, the HSI of fish significantly increased for all diets (Table 4) and both dietary protein and lipid levels had significant effects. As dietary protein increased from 450 to 550 g/kg, HSI decreased accordingly and, similarly, as dietary lipid level increased, HSI increased. Haddock accumulate dietary lipid in the liver (Nanton *et al.* 2001) and biochemical studies show that transport of lipid as lipoprotein from the liver to the muscle is low in haddock (Lall *et al.* 2003) and that there is limited catabolic activity ( $\beta$ -oxidation) of lipid in the liver (Nanton *et al.* 2003). These



factors can lead to the development of the ‘fatty liver’ condition in cultured haddock which is undesirable because these fish inefficiently utilize dietary energy. However, when juvenile haddock were fed up to 220 g/kg dietary lipid, although the HSI values were high (>12%), the histological examination of the livers did not reveal any overt pathologies or impaired liver function (Nanton 2002). This was also the case for Atlantic cod where fish fed 160 g/kg lipid had large livers but there was no evidence of impaired liver function (Morais *et al.* 2001). Nonetheless, fish with enlarged livers have lower somatic tissue growth (as a % of whole-body weight) than fish with smaller livers so minimizing the HSI in cultured haddock is of economic importance. A strong inverse correlation between DP/DE ratio and HSI (Pearson correlation coefficient, -0.79) was observed where the HSI values increased as DP/DE ratio decreased. The same effect has been observed in sharpnose seabream, *Diplodus puntazzo*, where fish on low DP/DE diets had significantly higher HSI and, conversely, fish on high DP/DE diets had significantly lower HSI (Hernández *et al.* 2001). Our results indicate that DP/DE ratios less than 29.3 g DP/MJ DE will produce haddock with HSI values greater than 9% and that haddock diets must contain at least 500 g/kg protein and 110 g/kg lipid to reduce the HSI. These results are in agreement with our earlier studies (Kim and Lall 2001; Kim *et al.* 2001; Nanton *et al.* 2001) that reported that good growth and minimal HSI can be achieved in juvenile haddock fed high levels of protein (500–550 g/kg) and low levels of lipid (<120 g/kg). The fact that HSI in haddock was regulated not only by dietary protein and lipid levels alone, but also by the combined effects of the DP/DE ratio has been observed in Atlantic cod where Jobling *et al.* (1991) suggested that accumulation of liver lipid was dependent not only upon total lipid content of the diet but also upon the relationship between the dietary nutrients. Whole-body moisture content (Table 4) of fish sampled after the 63-day growth period was significantly influenced by the dietary lipid content but unaffected by either DP/DE ratio or protein level. Although the range is small, it clearly shows that all diets containing higher lipid (160 g/kg), regardless of the level of other dietary nutrients, resulted in fish with lower moisture content than fish fed diets with lower lipid (110 g/kg). As there were no significant differences in whole-body ash and virtually no differences in whole-body protein content of the fish in this study, it can be concluded that the lower moisture content of the fish fed 160 g/kg lipid was as a

result of higher whole-body lipid gain in fish fed the higher lipid level which was indeed the case (Tables 4 and 5). Lipid, being high in energy (39.0 kJ/g), is translated into significantly higher whole-body energy gains (Table 5) in fish fed 160 g/kg lipid, which will be discussed further. The observation that whole-body ash and protein contents of the fish in this experiment were virtually unaffected by varying DP/DE ratio is consistent with the results for European sea bass where whole-body crude protein and ash contents were not affected by varying the levels of dietary protein, lipid and nitrogen-free extract (Lanari *et al.* 1999). The various levels of protein and lipid in the diets had highly significant effects on energy gains (Table 5). Within each dietary lipid level, increasing dietary protein from 450 to 550 g/kg, led to significant increases in energy gain. Similarly, within each dietary protein level, increasing dietary lipid from 110 to 160 g/kg led to significantly higher energy gains as well. Thus, the diet containing the highest levels of protein and lipid (28.5 g DP/MJ DE) resulted in the highest energy gain which was also the case for European sea bass (Lanari *et al.* 1999). However, we cannot conclude that this DP/DE ratio is the optimum because the goal of raising these fish is to produce marketable fish protein, which is in the form of the fillet flesh and not other components like viscera and liver. It has already been demonstrated that the diets with high dietary lipid (160 g/kg) all produced fish with enlarged livers (>11%). These enlarged livers, being high in lipid, contribute considerable amounts of energy to the whole-body energy content. It is better to examine whole-body nitrogen gain to have a better indication of production of the marketable product. The highest nitrogen gains (1.22–1.24 g/fish) were achieved when the DP/DE ratio was 28.5 and 30.2 g DP/MJ DE indicating that high nitrogen gains can be achieved with 550 g/kg protein, even at the lower lipid level (110 g/kg). However, these results were not reflected in nitrogen retention efficiency as the differences were not as pronounced. The nitrogen retention efficiency value (average, 40.7%) in this study is consistent with that reported previously for juvenile haddock (41%), while our value for energy retention efficiency (45.6%) is better than that reported previously for juvenile haddock (43%) (Kim and Lall 2001) and is as a result of a more appropriate DP/DE ratio. The best performance of haddock in this study was obtained with diets containing 28.5 and 30.2 g DP/MJ DE. However, 30.2 g DP/MJ DE is more appropriate than 28.5 g DP/MJ DE due to a build-up of energy in the

fish body which is not desirable if the energy retained is in the form of lipid, particularly liver lipid. Liver lipid is of no commercial value because it will ultimately be discarded with the liver during processing. Our recommendation of a diet containing 30.2 g DP/MJ DE rather than 28.5 g DP/MJ DE for juvenile haddock is supported by a significantly lower lipid gain observed in fish consuming the higher DP/DE ratio diet. To further confirm this fact, energy retention by the fish as 'lipid energy' or as 'protein energy' (Table 6) was calculated based on the work of Rodehutscord and Pfeffer (1999). These data clearly show that the fish fed diets containing 28.5 and 30.2 g DP/MJ DE had the highest amounts of energy retained as protein but the 30.2 g DP/MJ DE diet had a much lower and more acceptable level of energy retained as lipid. Energy retained as protein was highly regulated by dietary protein content (Pearson correlation coefficient = 0.86) whereas energy retained as lipid was highly regulated by both dietary lipid and DE levels (Pearson correlation coefficients = 0.94 and 0.70, respectively). Finally, a preliminary estimation of the maintenance energy requirement (DE<sub>m</sub>) was made by plotting the energy intake (kJ DE intake/fish/day) against the retained energy (kJ DE retained/fish/day) and regressing the curve back to neutral retained energy according to Rodehutscord and Pfeffer (1999). The relationship was characterized by the equation: DE retained = [(0.5621 × DE intake) - 1.1231], R<sup>2</sup> = 0.53, n = 18, P < 0.05. Thus, the DE<sub>m</sub> for juvenile haddock (13–60 g body weight) is 2.0 kJ DE intake/fish/day. Although additional data must be collected with larger samples sizes, different sized fish and under various water temperatures, this value is similar to the values reported for gilthead seabream (10–100 g body weight) of 1.2–8.2 kJ DE intake/fish/day (Lupatsch *et al.* 1998) and rainbow trout (1 g body weight) of 1.3 kJ DE intake/fish/day (Rodehutscord and Pfeffer 1999). It provides a good initial estimate of DE<sub>m</sub> for juvenile haddock diets for further nutrition research.

## Conclusions

All measured growth responses were lower when DP/DE ratio was 27.5 g DP/MJ DE or less. The diet containing 29.3 g DP/MJ DE produced fish with rapid growth, high nitrogen retention and reasonable HSI but digestibility, feed efficiency and nutrient gains were comparatively low. Diets containing 28.5 and 30.2 g DP/MJ DE performed the best

in virtually all cases, however, given the importance of producing haddock without enlarged fatty livers, a diet containing 30.2 g DP/MJ DE is recommended for juvenile haddock. This DP/DE ratio was achieved in a practical fish meal-based diet containing 548 g/kg protein, 114 g/kg lipid and 164 g/kg carbohydrate. This agrees with the previous recommendations for Atlantic cod (540 g/kg protein and >170 g/kg carbohydrate) and haddock (500–540 g/kg protein and >120 g/kg lipid).

### **Acknowledgements**

Financial support for this work was provided by Heritage Aquaculture Limited (Blacks Harbour, NB). Assistance by Laura Garrison with fish feeding and sample preparation during the growth experiments and Steven Leadbeater and Ben Levy during the digestibility experiments was gratefully appreciated. We acknowledge the generous donation of crab meal used in this study by Julien Albert of St Laurent Gulf Products Ltd (Caraquet, NB). The critical review and valuable suggestions of Dr Jeong-Dae Kim during the preparation of this manuscript is also greatly appreciated.

**Table 1** Composition of experimental diets with varying DP/DE ratios fed to juvenile haddock (*as-fed* basis)

DP/DE ratio	27	25	29	26	30	28
Protein (g/kg)	450	450	500	500	550	550
Lipid (g/kg)	110	160	110	160	110	160
<b>Ingredients (g/kg)</b>						
Herring meal <sup>1</sup>	453	470	545	560	635	640
Crab meal <sup>2</sup>	50	50	50	50	50	50
Corn gluten meal <sup>1</sup>	100	100	100	100	100	100
Wheat middlings <sup>3</sup>	281	214	193	127	125	70
Celufil <sup>4</sup>	50	50	50	50	35	35
Choline chloride <sup>4</sup>	6	6	6	6	6	6
Vitamin mixture <sup>5</sup>	10	10	10	10	10	10
Mineral mixture <sup>6</sup>	10	10	10	10	10	10
Herring oil <sup>7</sup>	40	90	36	87	29	79
<b>Analysis</b>						
Moisture (g/kg)	69	64	64	59	62	66
Crude protein (g/kg)	455	446	499	496	548	543
Lipid (g/kg)	106	150	112	157	114	165
Ash (g/kg)	92	90	101	99	112	109
Carbohydrate <sup>8</sup> (g/kg)	278	250	224	189	164	117
Energy (MJ/kg)	19.6	20.6	19.6	20.7	19.9	20.7
<b>Measured</b>						
DP (g/kg)	415	412	464	461	513	506
DE (MJ/kg)	15.1	16.6	15.8	17.2	17.0	17.7
g DP/MJ DE	27.5	24.7	29.3	26.7	30.2	28.5

<sup>1</sup> Corey Feed Mills Ltd (Fredericton, NB, Canada).

<sup>2</sup> St Laurent Gulf Products Ltd (Caraquet, NB, Canada).

<sup>3</sup> Dover Mills Ltd (Halifax, NS, Canada).

<sup>4</sup> United States Biochemical (Cleveland, OH, USA).

<sup>5</sup> Vitamin A, 8000 IU/kg; vitamin D3, 4500 IU/kg; vitamin E, 300 IU/kg; vitamin K, 40 mg/kg; thiamin, 50 mg/kg; riboflavin, 70 mg/kg; pantothenate, 200 mg/kg; biotin, 1.5 mg/kg; folic acid, 20 mg/kg; vitamin B12, 0.15 mg/kg; niacin, 300 mg/kg; pyridoxine, 20 mg/kg; ascorbic acid, 300 mg/kg; inositol, 400 mg/kg; butylated hydroxy toluene, 15 mg/kg; butylated hydroxy anisole, 15 mg/kg; ground wheat.

<sup>6</sup> Manganous sulphate, 40 mg/kg; ferrous sulphate, 30 mg/kg; copper sulphate, 5 mg/kg; zinc sulphate, 75 mg/kg; sodium selenite, 1 mg/kg; cobalt chloride, 2.5 mg/kg; sodium fluoride, 4 mg/kg; ground wheat.

<sup>7</sup> Shur-Gain Feeds (Truro, NS, Canada).

<sup>8</sup> Calculated as 1000 - (moisture + protein + lipid + ash).

**Table 2** Growth performance and feed utilization efficiency of haddock fed diets with varying DP/DE ratio for 63 days<sup>1</sup>

DP/DE (P/L)	Initial weight <sup>2</sup>	Final weight <sup>2</sup>	Weight gain <sup>2</sup>	Specific growth rate <sup>3</sup>	Feed intake <sup>2</sup>	Feed conversion ratio <sup>4</sup>	Protein efficiency ratio <sup>5</sup>
27.5 (450/110)	13.7 ± 0.2 <sup>nd</sup>	55.0 ± 0.5 <sup>a</sup>	41.4 ± 0.7 <sup>a</sup>	2.21 ± 0.03 <sup>a</sup>	32.6 ± 0.2 <sup>nd</sup>	0.79 ± 0.01 <sup>a</sup>	2.59 ± 0.02 <sup>a</sup>
24.7 (450/160)	13.4 ± 0.3	57.6 ± 0.8 <sup>b</sup>	44.1 ± 0.5 <sup>b</sup>	2.31 ± 0.02 <sup>b</sup>	33.5 ± 0.1	0.76 ± 0.01 <sup>ab</sup>	2.76 ± 0.03 <sup>b</sup>
29.3 (500/110)	13.6 ± 0.0	60.0 ± 0.5 <sup>bc</sup>	46.4 ± 0.5 <sup>bc</sup>	2.36 ± 0.02 <sup>bc</sup>	34.7 ± 0.7	0.75 ± 0.01 <sup>b</sup>	2.51 ± 0.02 <sup>a</sup>
26.7 (500/160)	13.3 ± 0.2	57.7 ± 0.2 <sup>b</sup>	44.4 ± 0.4 <sup>b</sup>	2.33 ± 0.03 <sup>b</sup>	32.9 ± 0.2	0.74 ± 0.00 <sup>b</sup>	2.57 ± 0.01 <sup>a</sup>
30.2 (550/110)	13.8 ± 0.0	61.5 ± 1.2 <sup>cd</sup>	47.7 ± 1.2 <sup>cd</sup>	2.37 ± 0.03 <sup>c</sup>	32.4 ± 0.6	0.68 ± 0.01 <sup>c</sup>	2.51 ± 0.04 <sup>a</sup>
28.5 (550/160)	13.2 ± 0.2	62.0 ± 0.8 <sup>d</sup>	48.8 ± 0.7 <sup>d</sup>	2.45 ± 0.00 <sup>c</sup>	33.7 ± 1.4	0.69 ± 0.02 <sup>c</sup>	2.58 ± 0.00 <sup>a</sup>

<sup>1</sup> Mean ± SE (n = 3). Values within the same column with different superscripts are significantly different (P<0.05).

<sup>2</sup> g/fish

<sup>3</sup> %/day

<sup>4</sup> g feed/g gain

<sup>5</sup> g gain/g protein intake

<sup>nd</sup> No significant differences detected.

**Table 3** Apparent digestibility coefficients<sup>1</sup> (%) of organic matter, energy, protein and lipid in diets containing varying DP/DE ratios

DP/DE (P/L)	Organic			
	matter	Energy	Protein	Lipid
27.5 (450/110)	69.1 ± 0.1 <sup>a</sup>	77.0 ± 0.5 <sup>a</sup>	91.2 ± 0.1 <sup>a</sup>	81.5 ± 1.8 <sup>a</sup>
24.7 (450/160)	73.0 ± 0.0 <sup>b</sup>	80.9 ± 0.1 <sup>b</sup>	92.4 ± 0.2 <sup>b</sup>	80.4 ± 1.6 <sup>a</sup>
29.3 (500/110)	76.2 ± 0.3 <sup>c</sup>	80.9 ± 0.9 <sup>b</sup>	93.1 ± 0.3 <sup>bc</sup>	82.4 ± 0.7 <sup>ab</sup>
26.7 (500/160)	77.3 ± 1.2 <sup>c</sup>	83.1 ± 1.0 <sup>c</sup>	92.9 ± 0.5 <sup>bc</sup>	88.7 ± 0.9 <sup>c</sup>
30.2 (550/110)	79.8 ± 0.2 <sup>d</sup>	85.6 ± 0.7 <sup>d</sup>	93.6 ± 0.4 <sup>c</sup>	86.2 ± 1.6 <sup>c</sup>
28.5 (550/160)	80.5 ± 0.5 <sup>d</sup>	85.7 ± 0.7 <sup>d</sup>	93.0 ± 0.3 <sup>bc</sup>	85.0 ± 0.4 <sup>bc</sup>

<sup>1</sup> Mean ± SE (n = 2). Values within the same column with different superscripts are significantly different (P<0.05).

**Table 4** Whole-body composition (wet-weight basis) and HSI of haddock fed diets with varying DP/DE ratios for 63 days<sup>1</sup>

DP/DE (P/L)	Moisture (g/kg)	Ash (g/kg)	Protein (g/kg)	Lipid (g/kg)	Energy (kJ/100 g)	HSI <sup>2</sup> (%)
Initial	815.0 ± 2.5 <sup>a</sup>	26.7 ± 1.4 <sup>nd</sup>	128.5 ± 3.0 <sup>a</sup>	18.2 ± 0.6 <sup>a</sup>	374.0 ± 5.0 <sup>a</sup>	5.3 ± 0.2 <sup>a</sup>
27.5 (450/110)	756.2 ± 2.5 <sup>b</sup>	26.6 ± 0.8	151.9 ± 2.0 <sup>c</sup>	37.4 ± 0.4 <sup>c</sup>	602.5 ± 11.3 <sup>b</sup>	10.9 ± 0.2 <sup>d</sup>
24.7 (450/160)	742.4 ± 3.8 <sup>c</sup>	26.1 ± 0.5	146.3 ± 1.4 <sup>b</sup>	52.8 ± 0.3 <sup>e</sup>	656.9 ± 15.5 <sup>c</sup>	12.6 ± 0.3 <sup>c</sup>
29.3 (500/110)	760.6 ± 2.5 <sup>b</sup>	26.3 ± 0.4	152.1 ± 1.6 <sup>c</sup>	32.4 ± 0.8 <sup>b</sup>	580.3 ± 9.6 <sup>b</sup>	9.3 ± 0.2 <sup>b</sup>
26.7 (500/160)	738.4 ± 3.2 <sup>c</sup>	26.0 ± 0.6	152.1 ± 1.2 <sup>c</sup>	48.8 ± 0.3 <sup>d</sup>	659.4 ± 13.8 <sup>c</sup>	11.9 ± 0.2 <sup>c</sup>
30.2 (550/110)	754.7 ± 3.2 <sup>b</sup>	25.2 ± 0.7	151.3 ± 1.4 <sup>bc</sup>	35.1 ± 0.8 <sup>c</sup>	603.3 ± 12.1 <sup>b</sup>	9.3 ± 0.2 <sup>b</sup>
28.5 (550/160)	740.7 ± 4.7 <sup>c</sup>	25.7 ± 0.8	154.2 ± 2.2 <sup>c</sup>	38.2 ± 1.5 <sup>c</sup>	652.3 ± 17.1 <sup>c</sup>	11.0 ± 0.4 <sup>d</sup>

<sup>1</sup> Mean ± SE (n = 3). Values within the same column with different superscripts are significantly different (P<0.05).

<sup>2</sup> HSI (%) = (liver weight/total fish body weight) × 100.

<sup>nd</sup> No significant differences detected.



**Table 5** Nitrogen, lipid and energy intake, gain (g or kJ per fish) and retention efficiency (%) of haddock fed diets with varying DP/DE ratios for 63 days<sup>1</sup>

DP/DE (P/L)	Nitrogen			Lipid			Energy		
	Intake	Gain	RE <sup>2</sup>	Intake	Gain	RE <sup>2</sup>	Intake	Gain	RE <sup>2</sup>
27.5 (450/110)	2.55±0.01 <sup>a</sup>	1.06±0.01 <sup>a</sup>	41.6±0.5 <sup>b</sup>	3.72±0.01 <sup>a</sup>	1.81±0.01 <sup>b</sup>	48.7±0.5 <sup>c</sup>	564.9±3.8 <sup>a</sup>	231.1±1.5 <sup>a</sup>	40.5±0.3 <sup>a</sup>
24.7 (450/160)	2.56±0.00 <sup>a</sup>	1.07±0.01 <sup>a</sup>	41.9±0.6 <sup>b</sup>	5.37±0.01 <sup>d</sup>	2.80±0.00 <sup>e</sup>	52.0±0.2 <sup>c</sup>	606.8±1.6 <sup>bc</sup>	270.0±0.7 <sup>bc</sup>	44.3±0.1 <sup>b</sup>
29.3 (500/110)	2.96±0.03 <sup>c</sup>	1.18±0.02 <sup>c</sup>	40.0±0.5 <sup>a</sup>	4.15±0.04 <sup>c</sup>	1.70±0.04 <sup>a</sup>	41.1±1.3 <sup>b</sup>	596.6±12.0 <sup>abc</sup>	244.6±4.9 <sup>a</sup>	40.6±0.8 <sup>a</sup>
26.7 (500/160)	2.77±0.01 <sup>b</sup>	1.13±0.01 <sup>b</sup>	40.8±0.4 <sup>ab</sup>	5.48±0.01 <sup>d</sup>	2.58±0.01 <sup>d</sup>	47.0±0.3 <sup>c</sup>	594.2±3.6 <sup>abc</sup>	271.5±1.6 <sup>bc</sup>	45.2±0.3 <sup>b</sup>
30.2 (550/110)	3.03±0.02 <sup>c</sup>	1.22±0.01 <sup>cd</sup>	40.1±0.5 <sup>a</sup>	3.94±0.03 <sup>b</sup>	1.91±0.04 <sup>b</sup>	48.5±1.3 <sup>c</sup>	565.5±10.0 <sup>ab</sup>	263.0±4.6 <sup>b</sup>	45.9±0.3 <sup>b</sup>
28.5 (550/160)	3.14±0.06 <sup>d</sup>	1.24±0.01 <sup>d</sup>	39.7±0.5 <sup>a</sup>	5.96±0.11 <sup>e</sup>	2.13±0.09 <sup>c</sup>	36.1±2.1 <sup>a</sup>	614.4±24.8 <sup>c</sup>	286.3±11.6 <sup>c</sup>	45.4±0.7 <sup>b</sup>

<sup>1</sup> Mean ± SE (n = 3). Values within the same column with different superscripts are significantly different (P<0.05).

<sup>2</sup> Retention (%) = (gain/intake) × 100.

**Table 6** Energy retention (kJ/fish) as either protein energy or lipid energy in haddock fed diets with varying DP/DE ratios for 63 days<sup>1</sup>

DP/DE (P/L)	Total retained Energy	Retained as protein energy <sup>2</sup>	Retained as lipid energy <sup>3</sup>
27.5 (450/110)	231.1 ± 1.5 <sup>a</sup>	157.9 ± 1.1 <sup>a</sup>	73.1 ± 0.5 <sup>a</sup>
24.7 (450/160)	270.0 ± 0.7 <sup>bc</sup>	159.5 ± 0.4 <sup>a</sup>	110.5 ± 0.3 <sup>d</sup>
29.3 (500/110)	244.6 ± 4.9 <sup>a</sup>	175.9 ± 3.5 <sup>bc</sup>	68.8 ± 1.4 <sup>a</sup>
26.7 (500/160)	271.5 ± 1.6 <sup>bc</sup>	168.1 ± 1.0 <sup>abc</sup>	103.5 ± 0.6 <sup>c</sup>
30.2 (550/110)	263.0 ± 4.6 <sup>b</sup>	180.9 ± 3.2 <sup>cd</sup>	82.0 ± 1.4 <sup>b</sup>
28.5 (550/160)	286.3 ± 11.6 <sup>c</sup>	185.3 ± 7.5 <sup>d</sup>	101.0 ± 4.1 <sup>c</sup>

<sup>1</sup> Mean ± SE (n = 3). Values within the same column with different superscripts are significantly different (P<0.05).

<sup>2</sup> Energy retention for protein was calculated for protein retention assuming 23.8 kJ/g retained protein.

<sup>3</sup> Energy retention for lipid was calculated for lipid retention assuming 39.0 kJ/g retained lipid.

# Chapter 5

## ***In vitro* pH-Stat protein hydrolysis of feed ingredients for Atlantic cod, *Gadus morhua*. 1. Development of the method.**

*This chapter has been published as:*

Tibbetts, S.M., Milley, J.E., Ross, N.W., Verreth, J.A.J., Lall, S.P. (2011) *In vitro* pH-Stat protein hydrolysis of feed ingredients for Atlantic cod, *Gadus morhua*. 1. Development of the method. *Aquaculture* 319, 398-406.

## Abstract

The method described here involves the extraction and partial purification of an enzyme fraction from the dissected pyloric caeca of commercially farmed Atlantic cod, *Gadus morhua* (1 kg fish) and the development of a pH-Stat method to predict protein digestibility. The various extraction and partial purification steps successfully concentrated the alkaline serine protease enzymes, trypsin (>4-fold) and chymotrypsin (>12-fold). It was found that the enzyme fractions produced in the manner described in this study were completely stable for up to 8 months when stored at -20°C and at least 10 months when stored -80°C after which significant loss of enzyme activity can occur, although the degree of protein hydrolysis (DH) of casein was unaffected after 12 months. It is recommended that enzyme fractions produced in a similar manner should be stored at -80°C and used within 8-10 months. The most suitable substrate concentration [S] to use for closed-system *in vitro* pH-Stat DH assays was established using a standard purified protein source (vitamin-free casein) with four [S] (0.25, 0.5, 0.75 and 1 mg N/mL protein suspension solution). No significant differences ( $P>0.05$ ) were found in the DH values between the [S] tested. The DH curve for casein at a [S] of 0.5 mg N/mL showed a rapid increase initially before leveling off at maximum DH (26%) which was achieved within a moderate duration of the assay (5-6 hours). The closed-system pH-Stat assay with a [S] of 0.5 mg N/mL and minimum assay duration of 8 hours is recommended for further investigation of conventional and novel feed ingredients for gadoid diets.

## Introduction

The pH-Stat assay has been used in human and animal nutrition research to estimate the *in vitro* protein digestibility of feed/food ingredients. The assay involves the proteolytic enzyme hydrolysis of a test protein substrate and directly measuring the breaking of peptide bonds. When protein bonds are cleaved, free carboxyl (-COOH) residues are liberated which allows for the exchange of hydrogen ( $H^+$ ) protons (Wei *et al.*, 2003). This release of positively charged hydrogen ions causes the reaction mixture to become more acidic. To counteract this decrease in pH, the pH-Stat titration system accurately adds titrant to maintain the target pH thereby eliminating the effects of

changing pH on proteolytic activity and also the effects of buffering caused by the newly released amino groups (Wei and Zhimin 2006). The pH-Stat system software accurately records the total volume of titrant required to maintain the target pH until protein hydrolysis is complete or the reaction is manually stopped. This titrant volume, combined with various other data, is then used to calculate the degree of protein hydrolysis (DH), which is a direct measurement of the number of peptide bonds that have been cleaved during protein hydrolysis.

Although several *in vitro* protein digestion techniques have been investigated with aquatic animals, pH-Stat methods have shown the most encouraging results with various species of finfish and shrimps (Alarcón *et al.*, 2002; Lemos *et al.*, 2009). In addition, some *in vitro* methods have been used to study larval nutrition that has been difficult to conduct *in vivo* due to their small size and alternatively with tuna and whales because of their large size (Carter *et al.*, 1999; Hansen *et al.*, 2009; Nordøy *et al.*, 1993). *In vitro* pH-Stat methods have also been used to predict performance of animals fed various feed formulations, to assess the effects of processing of plant protein supplements, to assist in designing new feed formulations and for producing novel feed/food hydrolysates (Adler-Nissen *et al.*, 1983; Lemos *et al.*, 2009; Lemos and Nunes, 2008). Significant success has been achieved with shrimps (Ezquerria *et al.*, 1997; 1998; Lemos *et al.*, 2009) while many investigations with finfish have encountered technological problems and poor repeatability (Dimes *et al.*, 1994a,b; Bassompierre, 1997; El-Mowafi *et al.*, 2000). *In vitro* pH-Stat methods have yet to be applied commercially to aquafeeds due the lack of a standardized method which result in poor reproducibility within and between laboratories and unaccounted variations in batch-to-batch enzyme activities. In addition, a poor understanding of the effects of dietary history of the donor animals on enzyme profile and catalytic activity may also lead to variations. The major limitations for *in vitro* pH-Stat assays appear to be the need for complete knowledge of enzyme origin and activity because variations in species, fish size/age and phenotype may give results with poor reproducibility and pH-Stat assays have also been found to give inaccurate results for ingredients that have been pre-hydrolysed. In addition, digestive tissues must be extracted from donor fish, necessitating a well-equipped analytical lab to produce enzyme fractions (Savoie, 1994).

Most *in vitro* pH-Stat protein hydrolysis studies with finfish and shellfish have used a finely ground test sample added to the reaction mixture at a substrate concentration [S] of 1-2 mg of N per mL of solution (Alarcón *et al.*, 1998; Carter *et al.*, 1999; Córdova-Murueta and García-Carreño, 2002; Dimes and Haard, 1994; Dimes *et al.*, 1994b; Ezquerra *et al.*, 1997; 1998; García-Carreño *et al.*, 1997; Lan and Pan, 1993; Shipton and Britz, 2002). However, the published literature does not appear to state the reason for these chosen values. From the stand-point of method development, the [S] is important because even small variations in the substrate protein concentration relative to the amount of enzyme present can have large effects on *in vitro* DH results (Alarcón *et al.*, 2002; Rothenbuhler and Kinsella, 1985; Wei and Zhimin, 2006). For example, Stinson and Snyder (1980) observed a significant decrease in the protein hydrolysis rate of soy protein (SP) and bovine serum albumin (BSA) when the [S] was increased from 0.8 to 1.1 mg N/mL (SP) and 0.8-3.2 mg N/mL (BSA). In addition, a wide range of hydrolysis duration times (less than 1 hour to over 48 hours) and hydrolysis temperatures (15-37°C) have been reported in the literature. These long duration times may be problematic. In an attempt to reduce the time required to achieve maximum degree of protein hydrolysis (DH), four substrate concentrations [S] were examined in this study (0.25, 0.5, 0.75 and 1 mg N/mL) under the hypothesis that food proteins have an inherent capacity for digestion and that all test [S] would eventually result in a similar DH.

If research and industry laboratories are to adopt a standardized *in vitro* technique for the rapid screening of protein quality of feeds and feed ingredients, a large supply of enzyme fractions stable over weeks or months is needed. Since stored enzymes can lose significant activity as a result of autohydrolysis, aggregation, protein unfolding and/or suboptimal buffering and storage conditions (Xi *et al.*, 2005), it is critical to assess the stability or 'usable shelf-life' of enzyme fractions over time and under typical laboratory storage temperatures. This quality-control aspect has received little attention previously. It has not been reported for studies on *in vitro* protein digestion using digestive enzymes extracted from fish or shellfish.

The present studies were designed to develop an enzyme extraction method and closed-system *in vitro* pH-Stat protein hydrolysis protocol that is relatively inexpensive and can be used to rapidly measure the degree of protein hydrolysis (DH) of feed

ingredients for gadoid fish. Particular aims were: 1) to monitor the relative activity of the two major serine protease enzymes (trypsin, chymotrypsin) extracted from farmed Atlantic cod pyloric caeca, 2) determine the stability, in terms of protein concentration and proteolytic activity, of the enzyme fractions stored at -20°C and -80°C over a period of 12 months and 3) determine the influence of the [S] on pH-Stat hydrolysis assays using a standard purified protein substrate.

## **Materials and methods**

### *Fish*

Twenty Atlantic cod (*Gadus morhua* L.) with an average weight of 1.2±0.1 kg were purchased from a commercial marine fish farm (Cooke Aquaculture Ltd., St. George, NB). The fish were cultured in Back Bay, NB in a standard floating marine sea cage and fed once daily (1200 h) with a commercial marine fish diet ('Europa 15', 4.0 mm Extruded Cod and Haddock Feed, Skretting Canada, St. Andrews, NB). The composition (*as-fed* basis) of this diet was: crude protein 55%, crude fat 15% and crude fibre 1.5%. The fish were fasted for 46 h before being removed from the sea cage and euthanized with an overdose (>100 mg/L) of tricaine methane sulfonate (AquaLife TMS, Syndel Laboratories Ltd., Vancouver, BC, Canada).

To assess the fish health status, several physical and physiological measurements were taken. Each fish was weighed (g) and measured for fork length (cm) to calculate their condition factor (*k*). Duplicate blood samples were collected with needle (18 gauge) and syringe (5 mL) from the dorsal caudal vein for determination of the packed red blood cell volume (hematocrit value, Hct). The blood was drawn into heparinized micro-hematocrit capillary tubes (Fisher Scientific Ltd., Pittsburgh, PA, USA) and centrifuged at 19,200 × *g* for 2 minutes in an IECMicro-MB centrifuge (International Equipment Company, Needham, MA, USA). Hct values were determined on a Lancer Critocap™ micro-hematocrit capillary tube reader (Sherwood Medical, St. Louis, MO, USA). The liver and pyloric caeca were dissected and visceral fatty tissues were removed. The tissues were rinsed with copious amounts of saline solution (0.9% NaCl) to remove contaminants (blood, urine, mucous, feed, feces, etc.) and then weighed to determine hepatosomatic index (HSI) and the pylorosomatic index (PSI). The liver and pyloric

caeca were quick frozen on dry ice, individually bagged and transferred to the National Research Council's Institute for Marine Biosciences, Marine Research Station (Ketch Harbour, NS) and stored at -80°C until further processing.

### *pH measurement of pyloric caeca homogenate*

Three frozen pyloric caeca were roughly chopped individually in a high-speed Bead-Beater (Biospec Products, Bartlesville, OK, USA) and transferred to 15 mL Falcon tubes where they were finely minced to a slurry with a PowerGen 700 homogenizer equipped with a 7 mm × 195 mm homogenizing probe (Fisher Scientific Canada, Ottawa, ON, Canada). The pH of each slurry was measured (in triplicate) with an Accumet® pH/Conductivity meter (model 20, Denver Instrument Company, Denver, CO, USA)

### *Protease enzyme extraction of pyloric caeca*

To ensure that the pyloric caeca used for enzyme preparation were from healthy and uniform fish, tissue from any animal displaying one or more of the following conditions was excluded: large (>1.3 kg) or small (<0.9 kg) body weight, obvious sexual maturation (as indicated by discrete, engorged gonads), high (>1.4) or low (<1.2) *k* factor, noticeable spinal and/or jaw deformity, caecal haemorrhaging and/or green liver. The extraction procedure was modeled after Dimes and Haard (1994) with modifications (Figure 1) and involved four steps: 1) crude enzyme extraction, 2) de-fatting, 3) enzyme stabilization and 4) enzyme concentration. All solutions used for enzyme extraction procedures were prepared fresh using Milli-Q water (Millipore Systems, Billerica, MA, USA) and kept at 4°C. In addition, all enzyme extraction procedures were carried out in a room at 4°C. The frozen pyloric caeca from eight fish were allowed to partially thaw for 80 minutes at 4°C before being finely chopped. A known weight (110 g) of finely chopped material was placed in a plastic beaker on ice and 3× the volume of extraction solution (0.05 M Tris, 0.2 M NaCl at pH 8.0) was added. It was then covered with aluminum foil and gently stirred for 5 hours at 4°C. The slurry (~330 mL) was centrifuged at 3200 × *g* for 10 minutes at 4°C and the supernatant (S<sub>1</sub> fraction) was removed and held on ice. Triplicate 0.5 mL aliquots of S<sub>1</sub> were taken, immediately



frozen on dry ice and transferred to  $-80^{\circ}\text{C}$  for subsequent determination of protein concentration and proteolytic enzyme activity of the crude extract.

The pellet was re-suspended with  $3\times$  the volume of extraction solution (0.05 M Tris, 0.2 M NaCl at pH 8.0) and an equal volume of ice-cold reagent-grade chloroform. It was vigorously shaken by hand before centrifuging again as above. The chloroform layer was discarded and the enzyme layer was pooled with the  $S_1$  fraction. Twenty % (by volume) of ice-cold reagent-grade chloroform was added to the  $S_1$  fraction, vigorously shaken and centrifuged as above. The enzyme layer was removed and the chloroform layer was discarded. Two % (by volume) of Brij<sup>®</sup> 35 was added to the enzyme solution (~650 mL) and it was gently stirred for 12 hours at  $4^{\circ}\text{C}$  before centrifuging. Triplicate 0.5 mL aliquots of the de-fatted extract were collected as described above. The de-fatted extract had 7.5% (by volume) 0.2 M  $\text{CaCl}_2$  added and it was stirred gently for an additional 17 hours at  $4^{\circ}\text{C}$ . The solution was centrifuged as above, the pellet discarded and ~645 mL of stabilized enzyme extract was produced. Triplicate 0.5 mL aliquots of the stabilized extract were collected as described above.

The enzyme solution was dialyzed using Specta/Por<sup>®</sup> cellulose dialysis membrane, mean weight cut-off (MWCO): 12,000-14,000 Daltons (flat width 45 mm; diameter 28.6 mm; Cole-Palmer). It was cut into 22 cm strips and soaked in Milli-Q water for 20 minutes and thoroughly rinsed with copious amounts of fresh Milli-Q water. The enzyme solution was transferred equally to five dialysis tubes and dialyzed for 24 hours at  $4^{\circ}\text{C}$  against 4 L of 0.01 M sodium phosphate (pH 7.8) while being gently stirred. Sodium phosphate was replaced with fresh solution after 8 hours and again after 16 hours. This step was performed to concentrate the target enzymes by the selective removal of non-target molecules such as peptides and smaller molecular weight proteins (<12 kDa). After 24 hours of dialysis, the solution was centrifuged as described above and the pellet discarded. A blank fraction was prepared by carrying out the same steps in the absence of pyloric caeca tissues.

The pH of enzyme and blank fractions was adjusted to pH 8.0 using 0.2 N NaOH prior to freezing at  $-80^{\circ}\text{C}$  according to Rothenbuhler and Kinsella (1985). The enzyme fraction (643.5 mL) required 1.5 mL of 0.2 N NaOH to bring it to pH 8.02 and the blank fraction (643.5 mL) required 1.4 mL to bring it to pH 8.03. Triplicate 0.5 mL aliquots

were collected as described above. The remainder was transferred (in 5.5 mL aliquots) to polypropylene cryogenic vials (80 vials for each fraction) and immediately frozen on dry ice and stored at either -20 or -80°C until required.

### *Measurement of protein concentration and protease activity*

Protein concentration of the enzyme fractions was measured by protein-dye binding according to Bradford (1976) with lyophilized bovine plasma gamma globulin (Bio-Rad Laboratories, Hercules, CA) as the standard. The measurement of activity was a modification of Gawlicka *et al.* (2000) and Laine *et al.* (1993). *L*-BAPNA (*N*<sub>α</sub>-benzoyl-*L*-arginine 4-nitroanilide hydrochloride, Sigma-Aldrich, St. Louis, MO) and Suc-AAPF-pNA (*N*-succinyl-alanine-alanine-proline-phenylalanine-*p*-nitroanilide, Sigma-Aldrich, St. Louis, MO) were used to measure the activities of trypsin and chymotrypsin, respectively. Fresh stock solutions of 1 mM *L*-BAPNA and 0.7 mM Suc-AAPF-pNA were prepared by dissolving the substrates in 1% anhydrous dimethyl sulfoxide (DMSO 99.9% pure, Sigma-Aldrich, St. Louis, MO) and making up to concentration in 0.1 M Tris-HCl, 0.02 M CaCl<sub>2</sub> at pH 7.9. Samples were thawed on ice, diluted (1:1 v/v) with 0.01 M sodium phosphate at pH 7.8 and kept on ice. Using a standard 96-well, flat-bottom plate, 10 μL of diluted sample was placed in triplicate wells along with 200 μL of either *L*-BAPNA substrate solution (for trypsin determination) or Suc-AAPF-pNA substrate solution (for chymotrypsin determination). The blank consisted of 10 μL of 0.01 M sodium phosphate at pH 7.8 and 200 μL of 0.1 M Tris-HCl, 0.02 M CaCl<sub>2</sub> at pH 7.9. The optical density (OD) at 405 nm was measured at 15 second intervals over a 30 minute period using a microplate reader in kinetic mode at 25°C. The linear portion of the curve that produced an R<sup>2</sup> value of >0.99 was selected to calculate the enzyme rate. Total activity of trypsin and chymotrypsin was calculated as follows:

$$\text{Total activity (U/}\mu\text{L)} = [\Delta\text{OD} \div (\epsilon \times l)] \times [V_t \div V_s] \times \text{DF}$$

where: U = amount of enzyme activity to produce 1 μmol of product per minute

ΔOD = change in optical density per minute

ε = extinction coefficient for *p*-nitroanilide at 405 nm (8800/M cm)

$l$  = light path in each well (0.623 cm)

$V_t$  = total assay volume (210  $\mu\text{L}$ )

$V_s$  = sample volume (10  $\mu\text{L}$ )

DF = dilution factor (2)

Specific activity was calculated as:

Specific activity (U/ $\mu\text{g}$  protein) = (total activity in U/ $\mu\text{L}$   $\div$  protein content in  $\mu\text{g}/\mu\text{L}$ )

### *In vitro degree of protein hydrolysis (protein DH)*

The closed-system pH-Stat hydrolysis assay procedure was conducted using equipment from Radiometer Analytical SAS (Lyon, France) and included an ABU901 autoburette connected to a PHM290 pH-Stat controller feeding data to MS-Excel-based PHM290\_E software. A hydrolysis temperature of 25°C was maintained with a Neslab RTE-111 heating/chilling recirculating waterbath and jacketed 100 mL capacity hydrolysis vessel. Prior to running a hydrolysis assay, a vial of enzyme fraction (or blank fraction) was thawed at room temperature for 15-30 minutes. The amount of vitamin-free casein required to produce 0.25, 0.5, 0.75 or 1 mg N per mL was placed directly into a 100 mL hydrolysis vessel with 50 mL of 0.02 M  $\text{CaCl}_2$  with 0.01%  $\text{NaN}_3$  and a magnetic stir bar. The suspension was gently stirred for 59 minutes to dissolve the soluble protein fraction and to stabilize the pH. This solution mixture was used because supplemental calcium helps stabilize the enzymes by reducing enzyme autohydrolysis throughout the assay and sodium azide ( $\text{NaN}_3$ ) acts as an effective antimicrobial agent to inhibit bacterial growth over the assay duration. The initial pH was adjusted to 8.0 using 0.2 N NaOH (pH 12.7). The assay pH of 8.0 was selected given the overwhelming body of knowledge showing that slightly alkaline pH promotes optimum catalytic activity of proteolytic enzymes extracted from pyloric caeca of cold-water marine fish and hepatopancreas of shrimps, crayfish and prawns and in particular for Atlantic cod Ásgeirsson *et al.*, 1989; Ásgeirsson and Bjarnason, 1991; Raae and Walther, 1989). This pH is also a requirement of the pH-Stat principle to function in alkaline medium with alkaline enzymes (>7.8, Adler-Nissen, 1986). Five mL of the thawed, vortexed enzyme fraction

(or blank fraction) were added to the hydrolysis vessel to initiate the pH-Stat assay. The volume of NaOH required to maintain the suspension at pH 8.0 over the hydrolysis duration (10 hours) was automatically logged in the software at 5 minute intervals and was used to calculate the degree of protein hydrolysis (DH). Each pH-stat assay was performed in duplicate on each test [S] for both the enzyme and blank fractions. Initial tests revealed that the pH electrode became unstable after several assays, presumably due to a build-up of protein and/or lipid. Soaking in acidic buffer (pH 4), washing with acetone followed by a distilled water rinse and then calibrating with pH 7.0 and 10.0 buffers (Caledon Laboratories Ltd., Georgetown, ON, Canada) prior to each DH assay resolved this problem. The procedure used a 'blank' prepared in the identical manner as the enzyme fraction except without any pyloric caeca. All enzyme fractions used for pH-Stat assays in this study had protein concentration and enzyme activities measured by the methods described above.

### *Calculation of degree of protein hydrolysis (DH)*

The titrant used in this procedure was sodium hydroxide (NaOH) and the exact normality of every fresh batch of ~0.02 N NaOH was standardized (in triplicate) against a known concentration of hydrochloric acid (HCl). The degree of protein hydrolysis (DH) was calculated according to Adler-Nissen, *et al.* (1983), Adler-Nissen, (1986) and Lemos, *et al.* (2009) as follows:

$$\%DH = (B \times N_b \times 1/\alpha \times 1/M_p \times 1/h_{tot}) \times 100$$

where:

B = consumption of NaOH for hydrolysis (mL) – consumption of NaOH for blank (mL)

$N_b$  = normality of NaOH titrant (meqv/mL)

$\alpha$  = average degree of dissociation of the  $\alpha$  – NH groups

$$1/\alpha = 1.5 \text{ at } 25^\circ\text{C and pH } 8.0 \text{ (Adler-Nissen } et al., 1983)$$

$M_p$  = total mass of protein (g) in the reaction mixture

(e.g. protein contributed from test ingredient and added enzyme)

$h_{tot}$  = total number of peptide bonds in casein (8.2 meqv/g protein, Adler-Nissen, 1986)

The DH data calculated every 5 minutes over the 600 minute (10 hour) hydrolysis assay was fitted to a best-fit regression curve (minimum  $R^2$  values of 0.99) according to Alarcon *et al.* (2007).

### *Statistical procedures*

Statistical analyses were performed according to Steel and Torrie (1960) using one-way analysis of variance (ANOVA), repeated measures analysis of variance (RM-ANOVA) and treatment means were differentiated using the pairwise multiple comparison procedures (Tukey multiple range test) using SigmaStat® v.3.5 software. A 5% level of probability ( $P < 0.05$ ) was chosen in advance to sufficiently demonstrate a statistically significant difference. All raw data was confirmed to have a normal distribution and constant variance using the Kolmogorov-Smirnov test (SigmaStat® v. 3.5).

## **Results and discussion**

### *Fish*

The fish were starved for 46 hours prior to sampling the pyloric tissues. This was done according to Lemieux, *et al.* (1999) working with similar sized Atlantic cod (40-50 cm vs. 44 cm average in this study) who found that after 2 days of feed withdrawal, less than 0.5% of the body weight consisted of food remaining in the gut. Dimes and Haard (1994) also used a 48 hour fast prior to collection of digestive enzymes from pyloric caeca of large rainbow trout (250-500 g). Gildberg (2004) has shown that the activities of digestive enzymes (particularly trypsin and chymotrypsin) remain at high levels in farmed cod over long (>10 days) starvation periods. The fish used for preparation of enzyme fractions (n=8) were of uniform size and body condition with average body weight of  $1.1 \pm 0.03$  kg, fork length of  $43.7 \pm 0.7$  cm, condition factor,  $k$  of  $1.3 \pm 0.0$ , hepatosomatic index, HSI of  $10.0 \pm 0.6\%$ , hematocrit value, Hct of  $26.5 \pm 0.9\%$ , pylorosomatic index, PSI of  $1.4 \pm 0.1\%$ , pyloric caeca pH of  $6.84 \pm 0.08$  and had no indication of sexual maturation, skeletal deformities, caecal haemorrhaging or green liver. The  $k$  factor reported here for commercially farmed cod in Atlantic Canada (1.3) is

similar (1.0-1.3) to that reported for commercially farmed cod in Norway and Iceland (Árnason *et al.*, 2010; Gildberg, 2004). In addition, the fish had a liver size index (HSI, 10%) which is typical of farmed gadoids in Atlantic Canada. Gildberg (2004) reported an HSI value of 14.4% but used fish fed a commercial feed (BioMar Ecolife 20% fat) that was 5% higher in lipid than the one fed to the cod in this study (Skretting Europa 15% fat). The 10% HSI value of the farmed cod used in this study is consistent with Árnason *et al.* (2010) who reported HSI values of 10-12% in similar sized cod fed diets containing 43-57% crude protein and 10-16% crude fat. The PSI of fish used in this study (1.4%) is in the same range (average, 1.1%, range 0.7-2.5%) as those measured previously in our lab with gadoids fed similar commercial gadoid feeds (unpublished results) and also commercially farmed cod in Norway (Gildberg, 2004). A schematic of the entire digestive tract of Atlantic cod is shown in Figure 2. The pyloric caeca in gadoids is relatively small compared to other species, representing only about ~5% of the total digestive tract length, ~12% of the fork length and ~1.5% of the fish body weight. For example, the PSI reported for farm-raised Atlantic cod in this study (1.4%) is much lower than that of rainbow trout which is 2.8-3.8% (Bassompierre *et al.*, 1998). Some morphological properties of Atlantic cod pyloric caeca have previously been reported by Buddington and Diamond (1986; 1987) and include the number of blind diverticula or caecal 'fingers' (222), average caecal diameter (1.2 mm), caecal length (2.5 cm) and caecal wall thickness (0.8 mm) and they also determined that the pyloric caeca of cod likely accounts for >70% of total enzymatic digestion, making it the most suitable digestive tissue for *in vitro* protein hydrolysis studies. The average packed red blood cell volume (Hct; 26.5%) and pH of the pyloric caeca homogenate (6.8) of the fish used in this study are within the typical ranges of 20-41% and pH 6.8-7.1, respectively reported for farmed marine fish (Hansen *et al.*, 2007; Lie *et al.*, 1990; Sandnes *et al.*, 1988; Danulat and Kausch (1984).

### *Protease enzymes*

The de-fatting steps used here were performed to reduce the amount of lipids in the mixture. Ezquerro *et al.* (1997, 1998) have shown that they can interfere with subsequent purification steps and that these particular solvents (chloroform and Brij® 35)

would be gentle enough so as to not cause protein damage and reduced enzyme activity. The calcium chloride ( $\text{CaCl}_2$ ) stabilization step was performed to provide the extract with supplemental calcium. This has been shown to favor the extraction of proteins (Bassompierre, 1997) and to help stabilize the enzyme extracts during frozen storage by reducing enzyme autohydrolysis (Kristjánsson, 1991). During enzyme activity assays, sodium phosphate was chosen as the diluent because of its very low buffering capacity ( $\text{pK}_a = 6.8$ ) and, as such, it has virtually no interference with the enzymatic hydrolysis of the purified substrates (Treimo *et al.*, 2008)

The ‘marker enzymes’ were trypsin and chymotrypsin because they have been clearly shown to make up the major enzymes produced by the pancreatic cells for proteolytic function in the pyloric caeca of cold-water fish including Atlantic cod. These enzymes have been well characterized in terms of structure, function and stability (Ásgeirsson *et al.*, 1989; Ásgeirsson and Bjarnason, 1991; Raae and Walther, 1989). They were tracked as marker enzymes since it is not possible (or useful) to track all enzymes present in a pyloric caeca-derived enzyme cocktail even though other important proteases (e.g. elastase, collagenase, aminopeptidases, etc.) likely play a role in conjunction with trypsin and chymotrypsin. Since their molecular weights are in the range of 24-26 kDa, the cellulose membrane used for dialysis (MWCO 12-14 kDa) was specifically selected to promote their retention along with other similar sized proteases.

The protein concentration and specific activities of the enzyme fractions throughout the various extraction steps along with the final blank fraction are shown in Table 1. Each extraction step reduced the total amounts of other components (e.g. other proteins, enzymes and lipids) resulting in an overall reduction in the total protein concentration from  $5.02 \pm 0.43 \mu\text{g}/\mu\text{L}$  to  $0.98 \pm 0.06 \mu\text{g}/\mu\text{L}$ . The protein concentration of the blank fraction was below the detection limit. The 80% decrease in protein concentration is less than previous reports (99%) with rainbow trout (Bassompierre *et al.*, 1993; Kristjánsson, 1991). This study was aimed at producing species-specific enzyme fractions easily and inexpensively. As stated by García-Carreño *et al.* (1993), full purification is time-consuming and expensive and not of value in an applied study such as this. Thus, we did not attempt to purify the fractions to the same extent as was reported in the previously mentioned studies where a final purification was performed by gel

permeation chromatography. The intent was to enrich a mixture of various proteases rather than isolation of single enzymes. If we compare our decreased protein concentration to that of rainbow trout to the point just prior to gel permeation chromatography (Kristjánsson, 1991), the results are the same (80.5 and 80.4%, respectively). Each extraction step was performed to enrich the total concentration of proteases and, in particular, the marker enzymes trypsin and chymotrypsin. Chymotrypsin is reported to be the most highly active protease enzyme in marine fish like Atlantic cod and Senegalese sole (Gildberg 2004; Gamboa-Delgado *et al.* 2011). Large increases in enzyme activities (trypsin, >4-fold, chymotrypsin, >12-fold) were measured throughout the extraction steps indicating that the extraction procedure was successful in concentrating these enzymes. The specific trypsin and chymotrypsin activity levels in the final extract were  $0.50 \pm 0.01$  and  $3.05 \pm 0.15$  U/ $\mu$ g protein, respectively, while the final blank fraction was confirmed to have no proteolytic activity (Table 1). Making enzyme activity comparisons with published literature is difficult. Reported values for fish pyloric caeca enzyme extracts processed at similar levels are highly variable due to species differences, nutritional history, culture conditions of donor fish used, extraction/purification techniques and different activity assay conditions (e.g. different substrates, incubation temperature and/or pH, method of calculation, reporting units, etc.) (Alarcón *et al.*, 1995; Hidalgo *et al.*, 1999; Pérez-Jiménez *et al.*, 2009).

### *Enzyme storage time and temperature*

One of the primary goals of this study was to assess the stability, in terms of protein concentration and proteolytic activity, of the enzyme fractions stored at  $-20^{\circ}\text{C}$  and  $-80^{\circ}\text{C}$  over a period of 12 months. The results provide very important quality-control information for this study and also for future studies with respect to the thermal stability or usable “shelf-life” of enzyme fractions produced in the manner described in this paper. It has been suggested that protein extracts stored in adequate buffer solutions in sterile glassware or polypropylene tubes maintain their shelf-life stability for ‘years’ when frozen at  $-20$  or  $-80^{\circ}\text{C}$  without an anti-microbial additive, although repeated freeze-thaw cycles can rapidly degrade them (Pierce Biotechnology Inc. 2010). The enzyme fractions produced for this study were extracted and stored frozen in Tris/NaCl and sodium



phosphate solutions in polypropylene cryogenic vials without an anti-microbial additive and were only thawed once. Measurement of the enzyme activity showed that under these conditions, the enzymes are indeed stable (Figure 3). Protein content of the enzyme fractions remained relatively constant over 12 months at storage temperatures of -20 and -80°C and the trypsin activity showed no significant change over 10 months, having retained over 94% of their initial activity. Although there was a significant activity loss by 12 months (83% of initial activity) when stored at -80°C, there was no significant difference relative to those stored at -20°C over the same period of time. At -80°C, the chymotrypsin after 12 months storage showed no significant loss of activity and retained 88% of its initial activity. However, when stored at -20°C, chymotrypsin showed a significant loss of activity after 8 months (70% of initial activity) and this may be related to the formation of protein damaging ice crystals that can form at -20°C when no cryoprotectant (e.g. glycerol, ethylene glycol, etc.) is used. This rarely occurs at -80°C provided there are not multiple freeze-thaw cycles (Pierce Biotechnology Inc., 2010). A similar study with Atlantic salmon showed that the pyloric caeca enzyme extracts exhibited good stability at -70°C having retained full activity for 3 months (Kristinsson and Rasco, 2000). However, the activity decreased to 80% of its initial activity after 4 months compared to 8-10 months for the cod enzyme extracts in this study. Given that pyloric caeca of cod is virtually free of visceral fatty tissues whereas salmon is completely engulfed in fatty tissues and together with the de-fatting steps in the present method, it is possible that the enzymes fractions produced in this study may have been less susceptible to degradation. As a final quality control check, the results of degree of protein hydrolysis (DH) of vitamin-free casein was compared using fresh enzyme fractions ( $T_{0 \text{ months}}$ ) versus ones stored for 12 months at -80°C ( $T_{12 \text{ months}}$ ). The DH was statistically the same ( $P=0.839$ ) with values of  $23.5\pm 1.8\%$  and  $23.3\pm 0.5\%$ , respectively. It is recommended that enzyme fractions produced by these methods be stored at -80°C and be used within 8-10 months.

### *Effect of varying substrate concentrations*

The pH-Stat assay temperature of 25°C is within the range of temperatures used in previous studies with finfish and shellfish (15-37°C). A temperature of 25°C was

selected in this study based on work with rainbow trout (Dimes *et al.*, 1994b) and also because it has been shown specifically for Atlantic cod pyloric caeca enzymes that the catalytic efficiency of trypsin-like enzymes is 17 times higher than that of bovine trypsin at 25°C (Ásgeirsson and Bjarnason, 1991). Bjarnason (2001) also reported the optimum catalytic temperature range for gadoid trypsin and chymotrypsin to be 20-40°C. The blanks run in these studies were used to account for background protein hydrolysis that occurs for non-enzymatic reasons (eg. stirring motion, hydration, atmospheric gases, pH-probe fluctuations, etc.). During early studies, Pedersen and Eggum (1983) assumed that measuring non-enzymatic hydrolysis was not necessary and would not increase the agreement between *in vitro* and *in vivo* results, while Alarcón *et al.* (2002) proved that this assumption was incorrect by demonstrating that non-enzymatic hydrolysis is highly variable between samples and can account for >35% of total protein hydrolysis. Pedersen and Eggum (1983) pointed out that *in vivo* digestion is a combination of both enzymatic hydrolysis and non-enzymatic hydrolysis, however, several authors have demonstrated better agreement between *in vivo* and *in vitro* results when non-enzymatic hydrolysis was accounted for. The research presented in this study is the first time a procedural blank has been used to account for pH-change that occurs from non-enzymatic hydrolysis, whereas previous studies with salmonids, other marine fish and shellfish have either used distilled water or no blank at all.

In previous pH-Stat studies with aquatic animals, protein substrate concentrations [S] in the range of 1-2 mg of N per mL of solution were used. The reason for this range is not clear and it is troubling from the stand-point of method development. Under highly-controlled conditions using purified trypsin as the enzyme and bovine serum albumin (BSA) as the protein substrate, Wei and Zhimin (2006) demonstrated a large effect of varying [S] (0.3-2.4 mg/mL) on protein hydrolysis rate and final DH. Use of 1-2 mg N/mL [S] may have originated from the original work of Hsu *et al.* (1977) and Maga *et al.* (1973) using an *in vitro* pH-Shift method with laboratory rats. In these studies, a high correlation between *in vitro* DH and *in vivo* protein digestibility was achieved within 3-10 minutes using 1-2 mg N/mL solution. Subsequent studies with aquatic animals appear to have adopted these [S] as the standard. Researchers working with salmonids, sparids, tuna, shrimps and abalone have used [S] in the range of 0.7 to

1.6 mg N/mL with differences in protein content and proteolytic activity of the enzyme fractions (Alarcón *et al.*, 1998; Carter *et al.*, 1999; Córdova-Murueta and García-Carreño, 2002; Dimes and Haard, 1994; Dimes *et al.*, 1994b; Ezquerro *et al.*, 1997; 1998; García-Carreño *et al.*, 1997; Lan and Pan, 1993; Shipton and Britz, 2002). However, these studies did not attempt to optimize the [S] for the assay. Only Alarcón *et al.*, (1999, 2002) working with seabream assessed the effect of varying [S] on DH.

Enzymatic assays of this type typically never reach a true plateau, rather they exhibit an initial rapid hydrolysis rate and then a much slower rate that is generally insignificant, making pH-Stat-generated curves difficult to model (Wei and Zhimin, 2006). A typical example with rainbow trout and carp shows that after about one-third of an 11.5 hour assay, the process of hydrolysis significantly slows down to what appears to be a plateau, but still rises slightly (Grabner, 1985). This is thought to be due to the ever-decreasingly available hydrolysis sites, enzyme exhaustion and enzyme autodigestion or activity inhibition by hydrolysis products, metal ions and/or indigestible residues and several other exogenous factors (Quaglia and Orban, 1987; Wei and Zhimin, 2006). The use of best-fit curve modeling allows for determination of the theoretical maximum DH and time required to achieve it as opposed to selection of arbitrary assay durations. The study results were also verified by comparing the linear slopes ( $R^2 > 0.99$ ) of each hydrolysis curve over the first 90 minutes of the assay.

For each pH-Stat assay conducted to determine the optimum [S], duplicate samples of each enzyme fraction were analyzed in triplicate to measure their enzyme activity levels (Table 2). There were no significant ( $P > 0.05$ ) differences in trypsin and chymotrypsin activities at 0.44-0.47 and 3.2-3.7 U/ $\mu$ L, respectively. Our results for the casein DH using Atlantic cod enzymes are in agreement with the relevant literature for salmonids. The maximum DH values were in a tight range of 23.0-25.6% (see Table 2 and Figure 4) with no significant ( $P > 0.05$ ) difference between the [S] tested. The casein DH achieved in this study (23-26%) is similar to the range reported for salmonids (23-27%; Dimes *et al.*, 1994a, Dimes and Haard, 1994) upon which this work was based. The assay duration time and volume of NaOH titrant required to achieve maximum DH was, however, proportionally affected by the [S] ranging from less than 5 hours to approximately 8 hours and less than 6 mL to greater than 21 mL, respectively. This

result demonstrates that the same DH can be achieved in a shorter period of time with less use of NaOH titrant, supporting our hypothesis that food proteins may have an inherent capacity for digestion and that the same maximum DH can be obtained using the pH-Stat assay regardless of [S]. Plots of [S] versus assay duration and titrant volume required shows significant linear relationships (Minutes =  $\{262.9 \times [S]\} + 209.3$ ,  $R^2=0.85$  and mL NaOH =  $\{21.4 \times [S]\} + 0.72$ ,  $R^2=0.99$ ) demonstrating the high proportionality between [S] and both assay duration and titrant consumption. A [S] of 0.5 mg N/mL was used for subsequent DH studies based on the curve progression over 10 hours having a rapid increase initially and then leveling off at maximum DH (26%) in a moderate assay duration (~6 hours) with minimal use of titrant (<12 mL). In addition, by comparing slopes of the linear portion ( $R^2>0.99$ ) of each hydrolysis curve over the first 90 minutes, the most rapid proteolysis clearly occurred at a [S] of 0.5 mg N/mL (>0.18). Thereafter, the rates fell to <0.12 at [S] of 0.75 and 1 mg N/mL. The use of 0.5 mg N/mL is also supported by non-linear regression analysis (Figure 5) that suggest the optimum [S] ( $DH = \{-12.4 \times [S]\}^2 + \{14.0 \times [S]\} + 21.3$ ,  $R^2=0.93$ ) to be 0.56 mg N/mL. This result closely supports that of Rothenbuhler and Kinsella (1985) working at 37°C with purified enzymes and various protein substrates (sodium caseinate, bovine serum albumin and defatted soy protein). They found the optimum [S] to be 3 mg protein/mL, when expressed in terms of nitrogen (N/P conversion factors of 6.38 for sodium caseinate and 6.25 for bovine serum albumin and defatted soy protein) equals 0.47 and 0.48 mg N/mL, respectively.

## Conclusions

These studies have demonstrated that the various extraction and partial purification steps successfully concentrated the alkaline serine protease enzymes, trypsin and chymotrypsin. Close agreement was found with published *in vitro* casein DH values for salmonids and Atlantic cod. The closed-system *in vitro* pH-Stat assay with a [S] of 0.5 mg N/mL and minimum assay duration of 8 hours is recommended for further investigation of conventional and novel feed ingredients for gadoid diets. It was also found that the enzyme fractions produced under the present extraction protocol were completely stable for up to 8 months when stored at -20°C and at least 10 months when

stored -80°C after which significant loss of enzyme activity losses can occur, although casein DH was unaffected after 12 months. As such, we recommend that enzyme fractions produced in a similar manner should be stored at -80°C and used within 8-10 months.

### **Acknowledgements**

We acknowledge the significant scientific inputs of Adel El-Mowafi, Prabir Roy, Sandra Molas and Ryan Gibbs during the various method development phases of these studies. We thank Frank Powell and Kenneth Tibbetts for valuable technical assistance during tissue sample collection in the field. The critical review and valuable suggestions of Dr. Daniel Lemos and Dr. Stephen Ewart during preparation of this manuscript is greatly appreciated.

**Table 1**

Protein concentration and specific activity of enzyme fractions<sup>a</sup> extracted from Atlantic cod pyloric caeca

Extraction step	Protein concentration ( $\mu\text{g}/\mu\text{L}$ )	Specific activity (U/ $\mu\text{g}$ protein)	
		Trypsin	Chymotrypsin
Crude extract	5.02 $\pm$ 0.43	0.12 $\pm$ 0.01	0.25 $\pm$ 0.03
De-fatted extract	2.02 $\pm$ 0.03	0.29 $\pm$ 0.00	0.95 $\pm$ 0.02
CaCl <sub>2</sub> stabilized extract	1.69 $\pm$ 0.02	0.33 $\pm$ 0.01	1.42 $\pm$ 0.01
Final extract after dialysis	0.98 $\pm$ 0.06	0.50 $\pm$ 0.01	3.05 $\pm$ 0.15
Final blank fraction	-0.10 $\pm$ 0.06	0.00 $\pm$ 0.01	-0.01 $\pm$ 0.02

<sup>a</sup> Mean  $\pm$  SE (n=3)

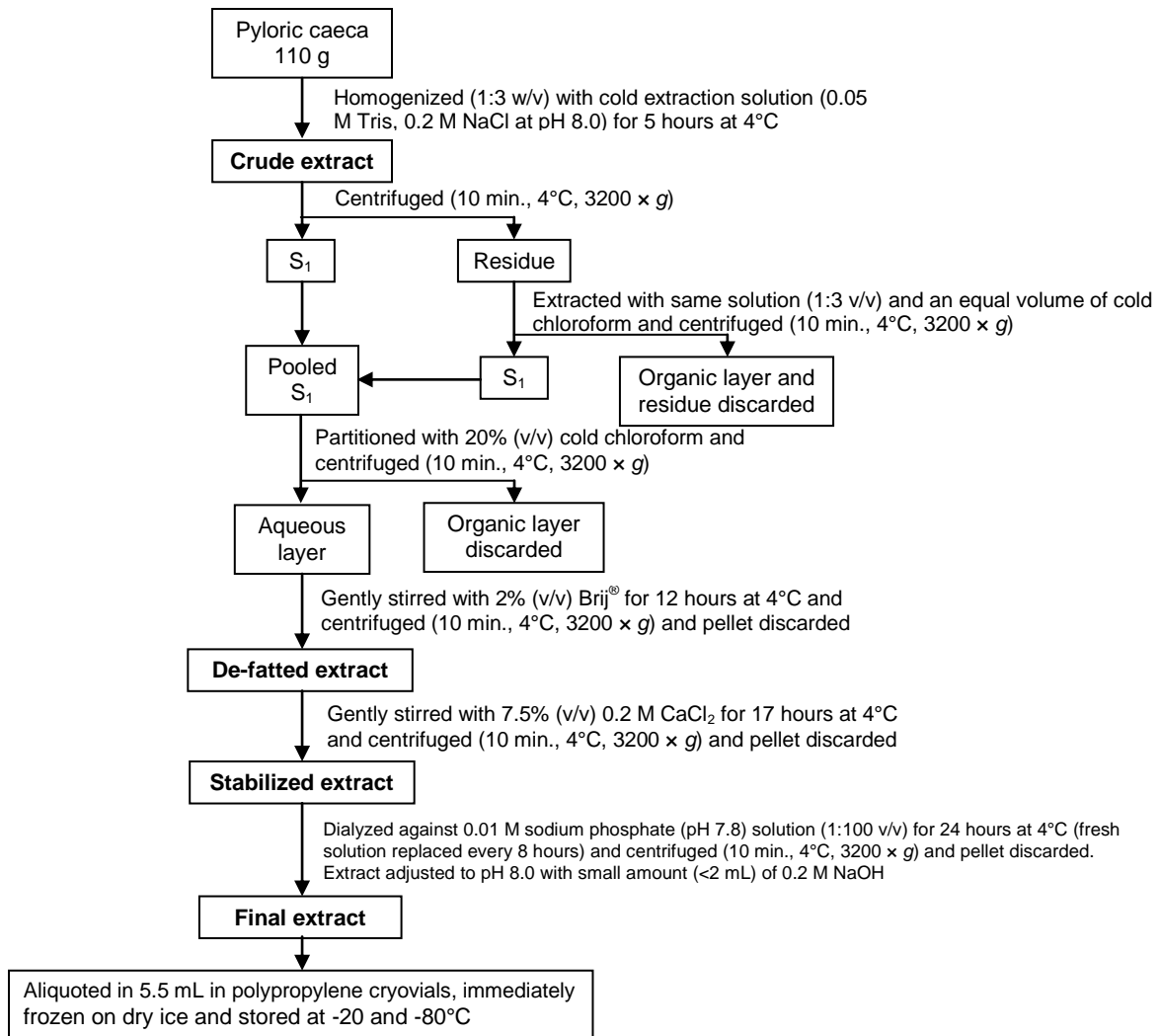

**Figure 1**

Flow diagram of the preparation of Atlantic cod proteolytic enzyme fractions

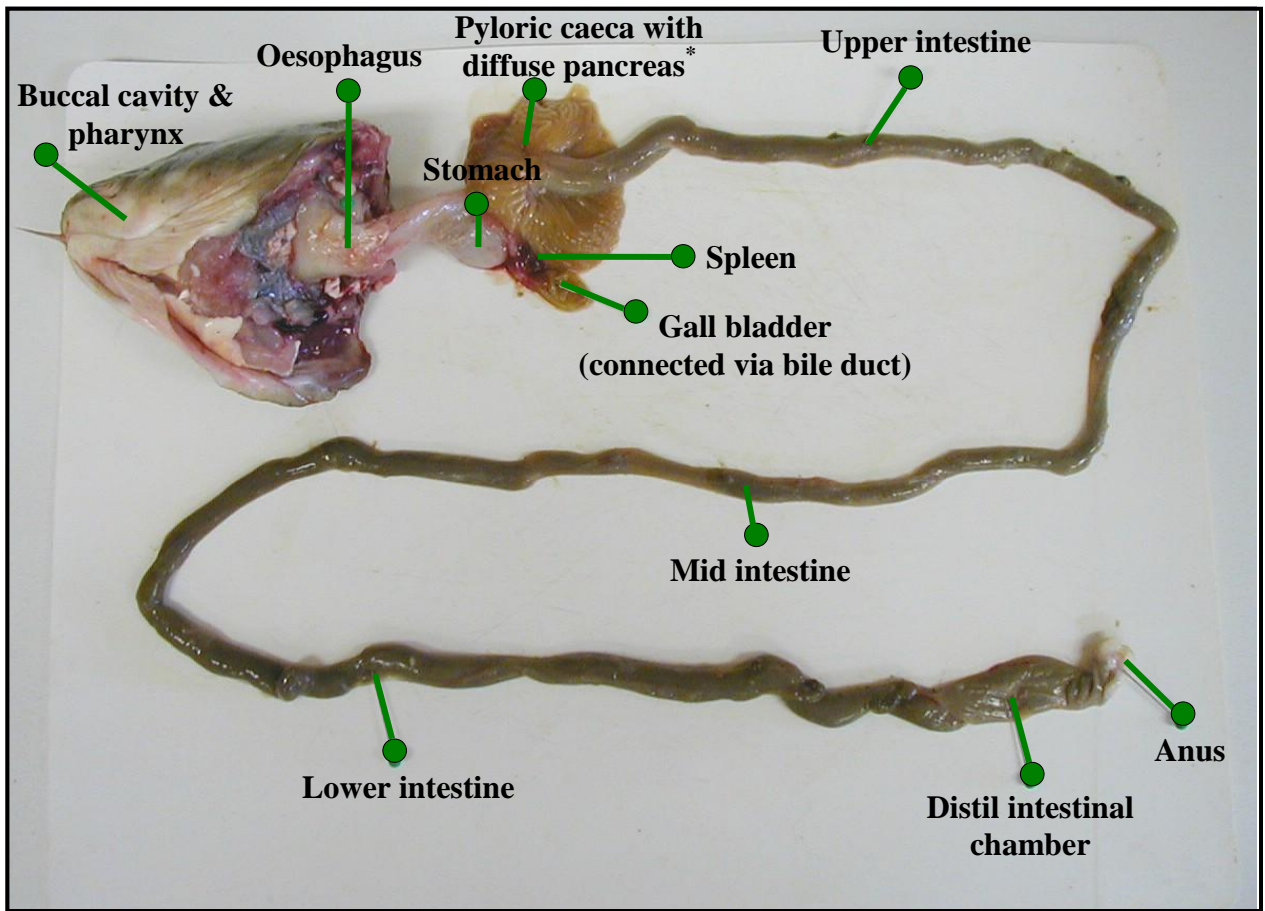

**Figure 2** Digestive tract of Atlantic cod, *Gadus morhua* (Linnaeus, 1758) with the liver removed. Measurements of the fish pictured above: fork length = 47.5 cm; entire digestive tract length (oesophagus to anus) = 101.0 cm (212.6% of fork length); pyloric caeca length = 5.5 cm (5.4% of intestinal length, 11.6% of fork length); stomach length = 3.0 cm (3.0% of intestinal length, 6.3% of fork length). \* Pancreatic cells diffused throughout the caecal tissues.



**Table 2**

Effect of substrate concentration [S] on pH-Stat degree of protein hydrolysis (DH)<sup>a</sup> of vitamin-free casein<sup>b</sup> using enzymes from Atlantic cod pyloric caeca

Substrate concentration (mg N/mL)	Enzyme activity <sup>c</sup> (U/μL)		Maximum DH <sup>d</sup> (%)		Assay time required (minutes)	Titrant required (mL)
	Trypsin	Chymotrypsin	Observed	Predicted		
1	0.46±0.01 <sup>ns</sup>	3.7±0.01 <sup>ns</sup>	23.6±0.2 <sup>ns</sup>	23.0±0.2 <sup>ns</sup>	463±9 <sup>a</sup>	21.6±0.2 <sup>a</sup>
0.75	0.45±0.02	3.5±0.13	24.9±0.2	24.5±0.4	433±36 <sup>ab</sup>	17.2±0.2 <sup>b</sup>
0.5	0.44±0.02	3.4±0.02	25.0±0.5	25.6±0.8	316±33 <sup>bc</sup>	11.8±0.7 <sup>c</sup>
0.25	0.47±0.01	3.2±0.01	23.4±0.1	23.9±0.2	282±1 <sup>c</sup>	5.6±0.1 <sup>d</sup>

<sup>a</sup> Mean ± SE (n=2); values within the same column with different superscript letters are significantly different (P<0.05)

<sup>b</sup> Casein - Vitamin-free (International Feed Number 5-01-162, analyzed nitrogen content of 13.475% (*as-fed* basis))

<sup>c</sup> Measured enzyme activity of pyloric caeca-derived enzyme fractions

<sup>d</sup> DH = degree of protein hydrolysis

<sup>ns</sup> = no significant differences (P>0.05) within column

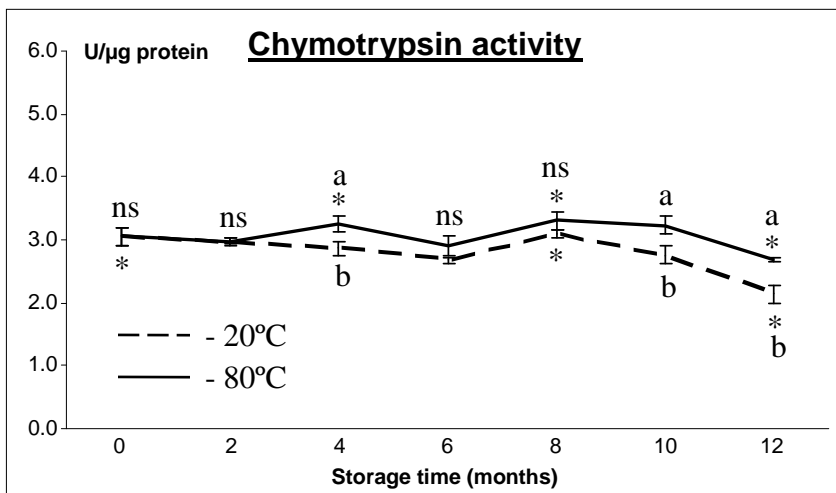
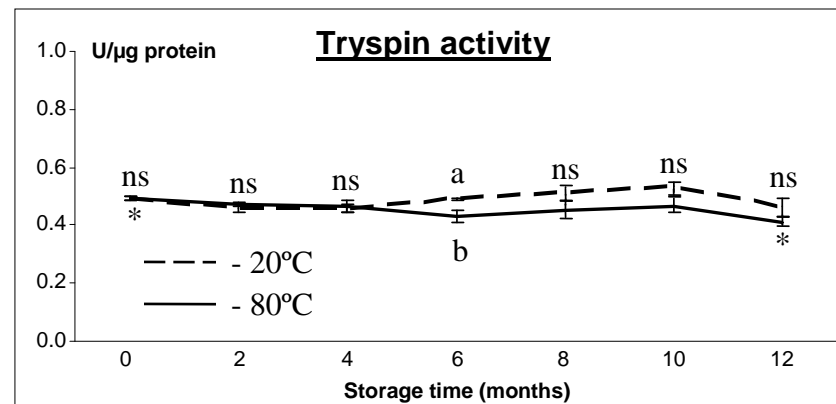
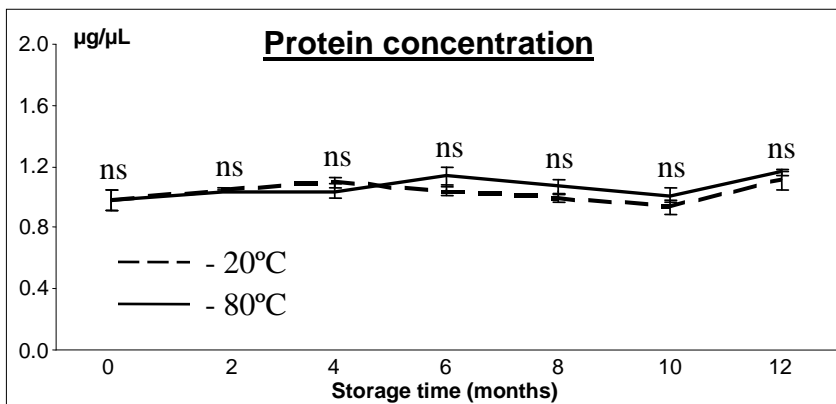

**Figure 3**

Stability of protein and enzyme activity of enzymes extracted from Atlantic cod pyloric caeca held at two storage temperatures for 12 months (mean  $\pm$  SE,  $n=3$ ). Different superscript letters indicate a significant difference ( $P<0.05$ ) between storage temperatures and an asterisk (\*) indicates a significant difference ( $P<0.05$ ) within the same storage temperature at different storage times. pH-Stat degree of protein hydrolysis (DH) of vitamin-free casein at  $T_{0 \text{ months}}$  ( $23.5 \pm 1.8\%$ ) was statistically the same ( $P=0.839$ ) as  $T_{12 \text{ months}}$  at  $-80^\circ\text{C}$  ( $23.3 \pm 0.5\%$ ).

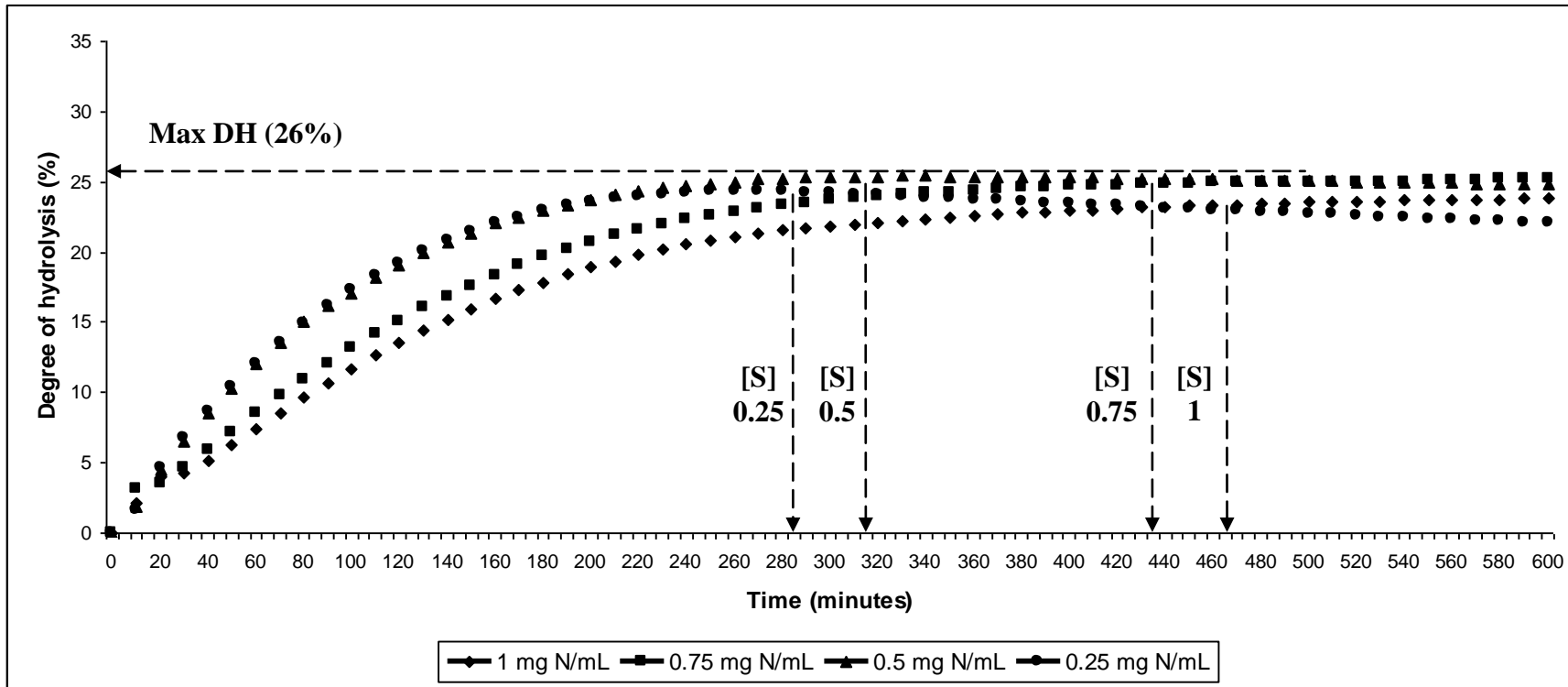

**Figure 4**

Effect of substrate concentration [S] on pH-Stat degree of protein hydrolysis (DH) of vitamin-free casein over 10 hours using enzymes from Atlantic cod pyloric caeca.

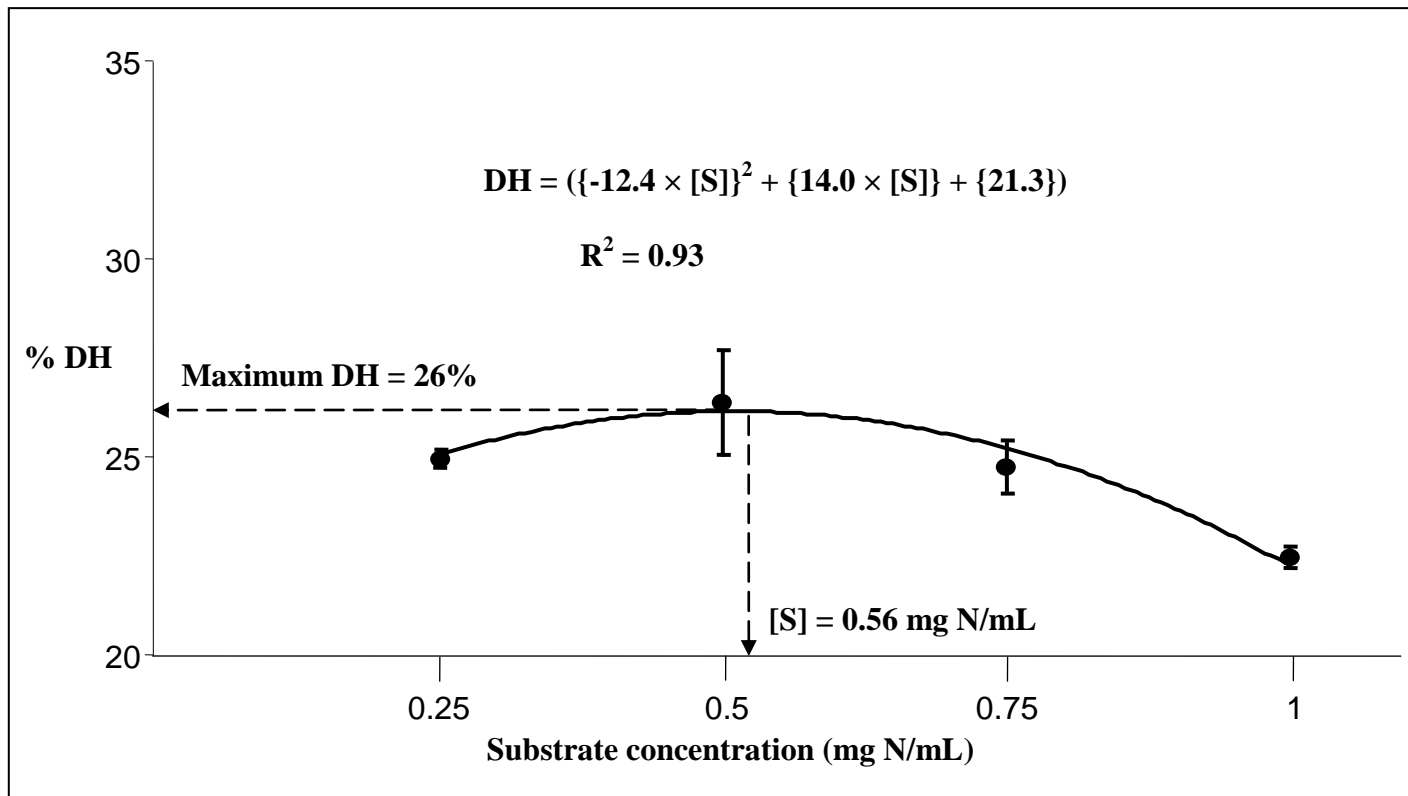

**Figure 5**

Effect of substrate concentration [S] on maximum *in vitro* degree of protein hydrolysis (DH) of vitamin-free casein using enzymes from Atlantic cod pyloric caeca.

# Chapter 6

***In vitro* pH-Stat protein hydrolysis of feed ingredients for Atlantic cod, *Gadus morhua*. 2. *In vitro* protein digestibility of common and alternative feed ingredients.**

*This chapter has been published as:*

Tibbetts, S.M., Verreth, J.A.J., Lall, S.P. (2011) *In vitro* pH-Stat protein hydrolysis of feed ingredients for Atlantic cod, *Gadus morhua*. 2. *In vitro* protein digestibility of common and alternative feed ingredients. *Aquaculture* 319, 407-416.

## Abstract

Using enzyme fractions isolated from the pyloric caeca of farmed Atlantic cod, the *in vitro* degree of protein hydrolysis (DH) of numerous conventional and novel feed ingredients were measured by a closed-system pH-Stat assay. Regression equations describing the relationship between *in vivo* apparent protein digestibility (ADC) and *in vitro* protein DH were used to predict *in vitro* protein ADC. The equations resulted in good correlation (<4 percentage points difference) between ‘measured’ and ‘predicted’ protein ADC in the majority of cases ( $r = 0.90-0.99$ ;  $R^2 = 0.88-0.99$ ), while some ingredients were either over- or under-estimated (6-7 percentage points) which appears related to high ash or chitin content ( $r = 0.75$ ;  $R^2 = 0.61$ ) and may indicate the need for an acid pre-hydrolysis phase and full account of non-protein nitrogen (NPN) content. The ‘predicted’ *in vitro* protein ADC were above 95% for wheat gluten meal, soy protein concentrate, soy protein isolate and whole krill meal; relatively high (85-95%) for soybean meal, white lupin meal, herring meal, anchovy meal, canola protein concentrate, pea protein concentrate and poultry by-product meal; mid-range (75-85%) for crab meal, shrimp meal and canola meal; and low (<75%) for hydrolyzed feather meal and flaxseed meal. Further research is needed on the development of a two-stage hydrolysis assay for gadoids involving an acid (gastric) pre-digestion step prior to this assay to further increase agreement between *in vivo* protein ADC and *in vitro* protein DH.

## Introduction

Fish, animal and plant by-products are widely available for use as major sources of dietary protein in fish feeds (Hardy, 2010; Hardy and Barrows, 2002). These products can vary considerably in their protein quality and nutrient profile depending upon the freshness, origin, species/cultivar, season of harvest and other factors associated with the raw material, particularly the drying process and temperatures used during processing (Pike, 1991; Lemos and Tacon, 2011). After preliminary chemical analyses, the major criterion for determining the nutritional value of a protein source is the measurement of its apparent digestibility coefficient (ADC) (Cho *et al.*, 1982). Conventional biological methods for measuring protein ADC involve *in vivo* fish trials that are time-consuming, require expensive facilities and use large numbers of animals. In addition, total

collection of feces from fish is typically not possible, so indirect methods must be used that involve the addition of inert markers to the diet (e.g. yttrium and chromic oxide) and then quantification in the diet and the dried fecal samples, which are costly. As such, *in vitro* methods such as the pH-Stat assay have been proposed to provide estimates of the protein digestibility of feed ingredients. The assay involves proteolytic enzymatic hydrolysis of peptide bonds in a test protein substrate and measurement of protein breakdown. When peptide bonds are cleaved, free carboxyl (-COOH) residues are liberated which allows for the exchange of hydrogen ( $H^+$ ) protons (Wei *et al.*, 2003). This release of positively charged hydrogen ions causes the reaction mixture to become more acidic. To counteract declining pH, the pH-Stat titration system accurately adds titrant to maintain the target pH thereby eliminating the effects of changing pH on proteolytic activity and also the effects of buffering caused by the newly released amino groups (Wei and Zhimin, 2006). The pH-Stat system software accurately records the total volume of titrant required to maintain the target pH until protein hydrolysis is complete or the reaction is manually stopped. This titrant volume, combined with various other data, is then used to calculate the degree of protein hydrolysis (DH), which is a direct measurement of the number of peptide bonds that have been cleaved during protein hydrolysis.

Under practical fish farming conditions, food intake and digestion are affected by numerous biotic and abiotic factors (e.g. culture conditions, water quality, presence of stressors, social interactions, changing feeding rhythms, nutritional and reproductive status (Lall and Tibbetts, 2009)) that can vary temporally and among stocks of fish. These factors, together with the documented effects of fish size/age, phenotype, dietary protein level and seasonal variations on proteolytic capacity (Bassompierre *et al.*, 1998b,c; Einarsson *et al.*, 1997; Førde-Skjærvik *et al.*, 2006; Kofuji *et al.*, 2005; Olsen and Ringø, 1998) influence food digestion in fish *in vivo*, negatively affect the reproducibility of both *in vivo* and *in vitro* results and ultimately complicate the application of *in vitro* results for use by the feed industry. Knowledge gaps will likely always exist; yet, it is recognized by human and animal nutritionists that it is possible to make reasonable predictions *in vitro* for research and industrial use (Fuller, 1991). *In vitro* methods can provide a complementary method to biochemical and *in vivo* biological

methods as they are relatively inexpensive, require less animals and results can be obtained rapidly (hours vs. weeks) using very small quantities of test sample. These characteristics could make *in vitro* methods more suitable for initial rapid-screening of protein quality and certainly more acceptable from the stand-point of animal welfare (Alarcón *et al.*, 2002 and Fernández-García *et al.*, 2009).

A small number of *in vitro* predictive equations currently exist in the literature for rainbow trout, *Salmo gairdneri* (Dimes and Haard, 1994) and white shrimp, *Litopenaeus vannamei* (Ezquerro *et al.*, 1997, 1998; Lemos *et al.*, 2009) but are lacking for all other farmed aquatic species. The objectives of this study were to: 1) measure the *in vivo* apparent protein digestibility (protein ADC) of a large number of conventional and alternative feed ingredients of fish, animal and plant-origin having a wide range of proximate composition using two related gadoid fish, Atlantic cod and haddock; 2) use our established protocol for enzyme extraction from Atlantic cod pyloric caeca and closed-system pH-Stat hydrolysis to measure the *in vitro* degree of protein hydrolysis (protein DH) of the same feed ingredients and 3) combine *in vivo* protein ADC and *in vitro* protein DH results to generate gadoid-specific predictive equations.

## **Materials and methods**

### *In vivo* apparent protein digestibility (protein ADC)

The *in vivo* protein ADC studies were conducted according to Tibbetts *et al.* (2004, 2006) with juvenile cod and haddock (90-94 g) that had been previously maintained in the lab and fed twice daily (0900 and 1600 h) a commercial extruded marine gadoid diet (EWOS™ 5.0 mm Marine Feed, EWOS Canada, Surrey, BC, Canada). The composition (*as-fed* basis) of this diet was: crude protein 55%, crude fat 12%, ash 11% and gross energy 21 MJ/kg. During a 2 week acclimation period (and for the duration of the study) the fish were fed experimental diets three times daily (0900, 1300 and 1600 h) that contained a 70:30 ratio (w/w basis) of basal diet (Table 1) and one of seventeen conventional or novel test feed ingredients. The reference diet and all experimental diets contained chromic oxide (Cr<sub>2</sub>O<sub>3</sub>, 0.5%) as the inert digestion indicator (Austreng, 1978) and the final proximate composition, gross energy content and *in vivo* protein digestibility (ADC) of the reference diet and experimental diets is shown in Table



2. The test ingredients were from a wide range of sources including fish meals, zooplankton meals, crustacean by-product meals, animal by-product meals and meals, concentrates and isolates of plant origin (including oilseeds, pulses and grains) and represented a wide range in proximate composition (31-86% crude protein, 0.3-15% lipid, 0.5-38% ash, 0-45% carbohydrate, 12-23 MJ/kg gross energy) and *in vivo* protein ADC (50-100%) (Table 3). Survival was high (>96%) for fish fed all experimental diets and feed intake exceeded 2% of body weight per day for all diets, with exception of the one containing pea protein concentrate.

The fish were housed in tanks (120 L capacity) equipped with fecal collection columns specifically designed to allow for daily collection of fecal samples from fish fed the various experimental diets (Tibbetts *et al.*, 2006). Filtered (<60 µm), de-gassed and UV-treated seawater (salinity, 28–30 ppt) was supplied to each tank at flow rates of 2-3 L/min in a flow-through system and continuously aerated (>9 mg/L dissolved oxygen; >90% gas saturation). The water temperature was maintained thermostatically (12°C) and monitored daily. Each week-day, after the final feeding (1600 h), the tanks and fecal collection columns were thoroughly cleaned with a brush to remove any residual particulate matter (feces and uneaten feed). Fecal samples were collected each morning (0830 h) into 250 mL plastic bottles, centrifuged (4000 rpm [2750 ×g] for 20 min at 4 °C) and the supernatant carefully decanted and discarded. Approximately 17–18 h elapsed between the last feeding of the day and fecal collection the following morning. Wet fecal material (minimum 40 g) was collected and pooled for 15-20 days for each experimental diet. Frozen (-20°C) fecal samples were lyophilized, finely ground using mortar and pestle and stored at -20°C until further analyses.

### *Analytical techniques and calculation of in vivo apparent protein digestibility (ADC)*

Test feed ingredients, experimental diets and lyophilized fecal samples were analyzed using the same procedures. Moisture was determined by drying in an oven at 105°C for 18 h and ash by incineration in a muffle furnace at 550°C for 18 h (Woyewoda *et al.*, 1986). Crude protein (% nitrogen × 6.25) was measured by the Dumas method (Ebeling, 1968) using a Leco nitrogen determinator (Model FP-528, Leco Corporation,

St. Joseph, MI, USA). Total lipid was determined using a modified Bligh and Dyer (1959) method. Organic matter was calculated by difference ( $100 - [\text{moisture} + \text{ash}]$ ) and carbohydrate was calculated by difference ( $100 - [\text{moisture} + \text{ash} + \text{protein} + \text{lipid}]$ ). Gross energy was measured using an isoperibol oxygen bomb calorimeter (model 6200, Parr Instrument Company, Moline, IL, USA) equipped with a Parr 6510 water handling system for closed-loop operation. Chromic oxide content of experimental diets and fecal samples was determined by flame atomic absorption spectrophotometry using an AAAnalyst 300 atomic absorption spectrophotometer (Perkin-Elmer, Norwalk, CT, USA) following a microwave acid digestion procedure as described by Peach (2005, pp. 52–54) using a Multiwave sample preparation platform system (Perkin-Elmer, Norwalk, CT, USA). *In vivo* protein ADC of the reference diet and experimental diets were calculated using the equation of Maynard *et al.* (1979 p. 41) and *in vivo* protein ADC for the single test feed ingredients was calculated according to Forster (1999).

### *Production of protease enzyme fractions*

Production of the enzyme fractions used in this study was described in detail in the previous method development studies (Tibbetts *et al.*, 2011). Briefly, the pyloric caeca tissues were removed from farmed Atlantic cod, *Gadus morhua* L. ( $1.2 \pm 0.1$  kg) from a commercial marine fish farm (Cooke Aquaculture Ltd., St. George, NB) that had been fed with a commercial marine fish diet ('Europa 15' 4.0 mm Extruded Cod and Haddock Feed, Skretting Canada, St. Andrews, NB) after a 46 hour fasting period. The composition (*as-fed* basis) of this diet was: crude protein 55%, crude fat 15% and crude fibre 1.5%. The pyloric caeca used were from healthy and uniform fish with 0.9-1.3 kg body weight, no obvious sexual maturation and 1.2-1.4 conditional factor (*k*). The enzyme extraction procedure was modeled after Dimes and Haard (1994) with modifications and involved four steps: 1) crude enzyme extraction, 2) de-fatting, 3) enzyme stabilization and 4) enzyme concentration. Procedural blank fractions were also prepared by carrying out the same steps in the absence of pyloric caeca tissues. Measurement of the trypsin and chymotrypsin enzyme activities was as previously described (Tibbetts *et al.*, 2011).

### *In vitro degree of protein hydrolysis (protein DH)*

The closed-system pH-Stat hydrolysis assay procedure was conducted as previously described (Tibbetts *et al.*, 2011). Prior to conducting a hydrolysis assay, a vial of enzyme fraction (or blank fraction) was thawed at room temperature for 15-30 minutes. The amount of test feed ingredient (passed through an 850 µm screen) required to produce 0.5 mg N per mL was placed directly into a 100 mL hydrolysis vessel with 50 mL of 0.02 M CaCl<sub>2</sub> with 0.01% NaN<sub>3</sub> and a magnetic stir bar. The suspension was gently stirred for 59 minutes to dissolve the soluble protein fraction and to stabilize the pH. The initial pH was adjusted to 8.0 using either 0.2 N NaOH (pH 12.7) or 0.2 M HCl (pH 1.9). Five mL of the thawed, vortexed enzyme fraction (or blank fraction) were added to the hydrolysis vessel to initiate the pH-Stat assay. The enzyme (or blank) fractions remaining in the tubes were subsequently analyzed for trypsin and chymotrypsin enzyme activities as previously mentioned to confirm enzyme activity uniformity across all pH-Stat assays. The volume of NaOH titrant required to maintain the suspension at pH 8.0 over the hydrolysis assay was automatically logged in the software at 5 minute intervals and was used to calculate the degree of protein hydrolysis (DH). Each pH-stat assay was performed in duplicate on each test ingredient for both the enzyme and blank fractions.

### *Calculation of degree of protein hydrolysis (DH)*

The titrant used in this procedure was sodium hydroxide (NaOH) and the exact normality of every fresh batch of ~0.02 N NaOH was standardized in triplicate against a known concentration of hydrochloric acid (HCl). The degree of protein hydrolysis (DH) was calculated according to Adler-Nissen, *et al.* (1983), Adler-Nissen, (1986) and Lemos, *et al.* (2009) as follows:

$$\%DH = (B \times N_b \times 1/\alpha \times 1/M_p \times 1/h_{tot}) \times 100$$

where:

B = consumption of NaOH for hydrolysis (mL) – consumption of NaOH for blank (mL)

N<sub>b</sub> = normality of NaOH titrant (meqv/mL)

α = average degree of dissociation of the α – NH groups

$1/\alpha = 1.5$  at 25°C and pH 8.0 (Adler-Nissen *et al.*, 1983)

$M_p$  = total mass of protein (g) in the reaction mixture

(e.g. protein contributed from test ingredient and added enzyme)

$h_{tot}$  = total number of peptide bonds in the test protein substrate (meqv/g protein)

where  $h_{tot}$  was 7.8 (soy proteins), 8.3 (wheat gluten proteins) and 8.35 (other proteins) (Adler-Nissen, 1986)

The hydrolysis equivalent ( $h_{tot}$ ) is dependent upon the amino acid composition of the specific protein being tested and when this is unknown, as in the majority of the cases in this study, an average value of 8.0 meqv/g protein for  $h_{tot}$  can be assumed (Adler-Nissen *et al.*, 1983). As such, other authors working with shrimps, salmonids and marine fish have used similar values in the range of 7.8-8.6 meqv/g protein. We chose to use 8.35 meqv/g protein for all unknown ingredients because it is the average value (excluding gelatin) of various food proteins recommended by Adler-Nissen (1986, Table 1, page 17).

### *Statistical procedures*

Statistical analyses were performed according to Steel and Torrie (1960) using one-way analysis of variance (ANOVA) and treatment means were differentiated using the pairwise multiple comparison procedures (Tukey multiple range test) using SigmaStat<sup>®</sup> v.3.5 software. Predictive regression equations were generated by regressing *in vivo* measured protein ADC against the corresponding *in vitro* protein DH using linear, log, power and exponential models using SigmaStat<sup>®</sup> v.3.5. Statistical significance of the correlations that best described the relationships were confirmed using Pearson correlation analysis ( $r$ ) and the coefficient of determination ( $R^2$ ) for each model. A 5% level of probability ( $P < 0.05$ ) was selected in advance to sufficiently demonstrate a statistically significant difference. All raw data was confirmed to have a normal distribution and constant variance using the Kolmogorov-Smirnov test (SigmaStat<sup>®</sup> v. 3.5).

## **Results and discussion**

### *Composition of the test feed ingredients*

The proximate composition and gross energy content of the test feed ingredients are reported in Table 3 and have been previously discussed (Tibbetts *et al.*, 2004, 2006). The proximate composition rarely correlates well with ultimate nutrient availability (Hardy and Masumoto, 1991), thus it is generally accepted that the first step in assessing the nutritional value of fish feed ingredients is to measure their digestibility (Cho *et al.*, 1982). Indeed, the proximate composition of the test ingredients was poorly correlated with *in vivo* protein ADC and *in vitro* DH with correlation coefficients (*r*) of -0.15 to 0.43 (*in vivo* protein ADC) and 0 to 0.45 (*in vitro* protein DH) for crude protein, lipid, ash, carbohydrate and gross energy, respectively. These results are in agreement with those for salmonids (Bassompierre, 1997), with corresponding *r* values of -0.06 to 0.47 (*in vivo* protein ADC) and -0.24 to 0.3 (*in vitro* protein DH).

#### *DH of animal-origin feed ingredients*

*In vitro* DH of the animal-origin feed ingredients is presented in Table 5. DH values were highest (11-12%) for poultry by-product meal, herring meal and anchovy meal, mid-range (7%) for whole krill meal; and lowest (3-4%) for crab meal, shrimp meal and hydrolyzed feather meal. The *in vitro* DH results for fish meals and poultry meals are in good agreement with conventional *in vivo* protein ADC results that also show relatively high protein digestibility for herring, anchovy and poultry by-product meals and low protein digestibility for hydrolyzed feather meal. The *in vitro* DH results for fish meals (12%) are in close agreement with Dimes *et al.* (1994a) and Kristinsson and Rasco (2000) who reported DH values of 10-14% for the hydrolysis of salmon muscle protein, ocean perch muscle protein and herring meal using rainbow trout and Atlantic salmon pyloric caeca enzymes.

The *in vitro* DH results for zooplankton and crustacean meals indicated lower digestibility than those using *in vivo* protein ADC methods and there are a couple of possible explanations. Firstly, the amount of each of these ingredient used in each DH assay was calculated based upon its total protein content using a nitrogen (N) analyzer and a general protein conversion factor of  $N \times 6.25$ , since no specific conversion factor is available for these ingredients. This 6.25 conversion factor is the most widely used value for feed protein sources of plant and animal origin (Tacon *et al.*, 2009) and were applied

in the original *in vivo* protein ADC studies to ingredients and complete diets. However, use of this conversion factor is based on the assumptions that the protein source contains 16% nitrogen, which is not always the case, and that the content of non-protein nitrogen (NPN) such as free amino acids, nucleic acids, ammonia and nitrogenous glycosides, etc. is negligible. When these assumptions are not met, an over-estimation of true protein content results (Fujihara *et al.*, 2008). For the zooplankton and crustacean meals, the total amount of intact protein was likely over-estimated because of a relatively higher proportion of N in the form of NPN. Zooplankton and crustacean feed ingredients may contain significant levels of chitin (10-20%) and free amino acids (>2%) (Hertrampf and Piedad-Pascual 2000; Heu *et al.* 2003). In addition, it is possible that the krill and crustacean products used in this study may have retained some endogenous enzyme activity that may be rapidly triggered causing partial post-mortem protein hydrolysis after capture at sea (within 6-8 hours) prior to final processing (Kolakowski 1986) resulting in elevated levels of NPN (e.g. volatile bases, trimethylamine, free amino acids, peptides, ammonia). Various authors have reported that freshly harvested krill and crustaceans with NPN levels of less than 10 g N/100 g can exceed 50 g N/100 g within 24 hours (Kolakowski 1986; Fagbenro and Bello-Olusoji 1997; Heu *et al.* 2003). If this were the case, these ingredients would have a comparatively high content of NPN that may not affect apparent *in vivo* protein ADC (since it is based on N ratios between diet and faeces) but could influence *in vitro* protein DH if the specific enzyme cleavage sites along those polypeptides (during *in vitro* protein hydrolysis) have previously been cleaved (Córdova-Murueta and García-Carreno, 2002). A similar situation was documented by Ezquerro *et al.* (1997) while measuring the *in vitro* DH of *langostilla* crab meal using shrimp hepatopancreas-derived enzymes. The implication of these scenarios is an altered ratio of enzyme to intact protein substrate and this may have artificially resulted in lower *in vitro* DH than anticipated. Secondly, and likely the major cause for the lower *in vitro* DH results, involves the method used in this study that used enzymes extracted from the pyloric caeca of gadoid fish which function at a pH of 7 or higher (Danulat and Kausch, 1984). Unlike other animal and plant protein sources, the major by-product of zooplankton and crustacean processing is the carapace or shell which may contain 50–80% chitin (poly- $\beta$ -(1 $\rightarrow$ 4)-N-acetyl-glucosamine) and relatively high levels

of ash (>15%) which have both shown high digestibility in gadoids measured *in vivo* (Danulat, 1987; Danulat and Kausch, 1984; Toppe *et al.*, 2006). The problem is that under the *in vivo* conditions, these ingredients are exposed to an environment of acidic pH (3.8-6.5) and endogenous chitinase enzymes in the stomach 'prior to' entry into the alkaline (>pH 7) pyloric caeca (Danulat and Kausch 1984; Grabner 1985; Jeuniaux 1966). This *in vivo* 'preparatory' gastric phase is unavailable in a pH-Stat assay using digestive enzyme from the pyloric caeca only. In fact, Danulat and Kausch (1984) demonstrated that the activity of chitinase enzyme in the gadoid pyloric caeca is lower than that of the stomach and what little chitinolytic activity does exist in the pyloric caeca is not optimized at pH levels above 6.5. This is in agreement with other monogastric animals like poultry that showed that the acid (gastric) phase was critical for chitin and chitosan digestion because it provides a preparatory phase whereby acidic gastric juices dissolve and swell the molecules, thus permitting higher substrate availability for chitinase enzyme activity (Hirano *et al.*, 1990) and subsequent alkaline protease activity. Since the enzyme fractions used in these *in vitro* studies were extracted only from the pyloric caeca at pH 7, these particular test ingredients lacked the benefit of a preparatory low gastric pH and chitinase pre-exposure phase that they would have had during *in vivo* digestion and not as important for the other low-chitin, low-ash feed ingredients. Thus, it is not surprising that the ash and chitin-rich crustacean meals could be less digested under these specific *in vitro* conditions and especially for the particular sample of shrimp meal used in these studies which contained an unusually high level of ash (38%). Bassompierre *et al.* (1998a) found improved agreement between *in vivo* protein utilization (measured in rats) and *in vitro* protein DH (measured in rainbow trout) when an *in vitro* acidic (pH 3.8) gastric phase was implemented prior to the *in vitro* alkaline (pH 7.8) intestinal digestion phase. Similar increases in *in vitro* DH following an acid pre-step have been demonstrated using rainbow trout pyloric caeca enzymes (Grabner and Hofer, 1985) and purified mammalian enzymes (Rothenbuhler and Kinsella, 1985). However, many authors concluded that the improvement was only marginal and resulted in a more complex and time-consuming assay, which may not be practical for use by the feed industry. Alarcón *et al.* (2002) also found higher DH values with seabream after an acid pre-digestion, although the improvement was only observed for some ingredients

(corn gluten meal, meat and bone meal, fish meal, soybean meal and blood meal) but not others (squid meal, lupin meal and green pea meal). Similarly, Rothenbuhler and Kinsella (1985) observed that an acid pre-treatment greatly enhanced the *in vitro* DH of soy protein and casein but reduced it for bovine serum albumin. Recent work with other fish species on the development of a gastrointestinal model (GIM) that incorporates both the gastric acidic and intestinal alkaline phase, the use of bile salts and also a pH 'transition' phase (Hamdan *et al.*, 2009; Morales and Moyano, 2010) may also be useful for gadoid species. The low nutritional value of hydrolyzed feather meal found both *in vivo* and *in vitro* was not unexpected as it is consistently reported to be low when fed to most fish species and other terrestrial animals. The low nutritional value may be due to high levels of poorly digestible keratin protein (Dong *et al.*, 1993; Hardy and Barrows, 2002; Yu *et al.*, 2004), an inferior essential amino acid profile with low levels of methionine, lysine, histidine and tryptophan, the presence of disulfide bonding (Moran *et al.*, 1966) and the presence of indigestible amino acid processing products, namely lysinoalanine and lanthionine (Williams *et al.*, 1991; Wang and Parsons, 1997). This limits the use of high proportions of feather meal in gadoids feeds. Cost-effective processes that can further increase the protein digestibility of feather meals could greatly increase their feeding value and provide an excellent high protein alternative ingredient for marine fish and other animal feeds (Bertsch and Coello, 2005).

### *DH of plant-origin feed ingredients*

*In vitro* DH of the plant-origin feed ingredients is presented in Table 6. DH values were highest (17-21%) for wheat gluten meal, soy protein isolate, soy protein concentrate and canola protein concentrate; high (10-13%) for soybean meal, white lupin meal and canola meal and mid-range (6-9%) for pea protein concentrate and flaxseed meal. No results could be determined for corn gluten meal because, unlike other ingredients, the hydrolysis curve remained linear over the entire 10 hour assay. This result was initially confirmed after repeating the assays 4 additional times. For further confirmation of this result, the corn gluten meal assays were repeated again in duplicate over a 20-hour assay duration and linearity remained, therefore making it impossible to determine a maximum DH. The cause for this situation remains unknown but may be



related to the fact that glutelin proteins, which account for a large proportion of CGM protein, are relatively insoluble in water (de Rodríguez *et al.* 2011). Kiliç Apar and Özbek (2010) successfully hydrolyzed the protein in corn gluten meal in a pH-Stat assay however, they used much higher assay temperatures (40-60°C) and a high-activity purified commercial bacterial endopeptidase enzyme. Lemos *et al.* (2009) determined DH values for corn gluten meal (2-4%) using an enzyme cocktail from Pacific white shrimp hepatopancreas and found poor agreement between *in vitro* DH and *in vivo* protein ADC.

The results for wheat gluten meal, all soy-based products and white lupin meal are in agreement with conventional *in vivo* protein ADC results that also show high to very high protein digestibility for these ingredients (90-100%). In contrast, it appears that *in vitro* DH may over-estimate the relative protein quality for canola protein concentrate, canola meal and flaxseed meal, as their *in vivo* protein ADC were high (89%), mid-range (76-83%) and low (53%), respectively while their *in vitro* DH were very high (17%), high (12%) and mid-range (9%), respectively. The relatively high DH found for these ingredients is consistent with results for canola protein concentrate found during earlier *in vitro* digestion studies with rainbow trout and rats, where relatively higher DH was also observed (Dimes and Haard, 1994; Gauthier *et al.*, 1982; Henry and Ford, 1965). Under *in vivo* conditions, inclusion of dietary ingredients containing high fibre typically results in lowered protein digestibility (reduced protein ADC) in fish feeds and this is attributed to decreased proteolytic enzyme activity (Falge *et al.*, 1978) and shortened gut-transit time (Jobling, 1981; Steffens, 1989). By contrast, the high indigestible fibre content of these ingredients tends to elevate digestibility estimations (increased protein DH) under *in vitro* situations. It has been shown that the fibre component of some plant-based feed ingredients have especially high buffering capacity in the presence of proteolytic enzymes and this high fibre content and subsequent high buffering capacity requires excessive use of NaOH titrant causing over-estimates of protein digestibility via *in vitro* methods (O'Hare *et al.*, 1984). The *in vitro* pH-Stat assays used a procedural blank to account for this high buffering capacity and other sources of non-enzymatic hydrolysis, whereas previous studies with salmonids and other marine fish and shellfish have either used a distilled water blank or no blank at all. Although processing conditions play a

large role in protein quality of feed ingredients of both plant and animal-origin, it has been suggested that when higher *in vitro* protein DH values are observed for plant-origin ingredients, the primary causes may also be due to higher protein solubility, higher percentage of amino acids that are susceptible to alkaline protease cleavage and differences in peptide bond flexibility (Alarcón *et al.*, 2002).

It has been shown in other species of fish and shellfish that potential inconsistencies between *in vitro* protein DH and *in vivo* protein ADC based on quantification of fecal nitrogen may involve the effects of ingredient composition, dietary inclusion level and poor palatability (Lemos *et al.*, 2009). It is likely that the use of 30% plant protein substitution in the initial *in vivo* protein ADC trials may have been too high given the low palatability of some plant protein ingredients. It has been demonstrated for gadoids that inclusion levels of 10-50% fish meal and 10-40% soybean meal had no significant effect on *in vivo* protein ADC (Kim *et al.*, 2006, 2007), however, it remains unclear what the effect would be with other less digestible, less palatable ingredients. It is highly likely that some of the ingredients used in this study may not be used at the 30% replacement level under practical, commercial aquafeed conditions due to undesirable proximate composition, inferior amino acid profile, palatability problems, pelletability/extrudability problems, anti-nutritional factors and cost. The robustness of the correlations between *in vivo* protein ADC and *in vitro* protein DH could be greatly strengthened with further determination of *in vivo* protein ADC data conducted at more practical ingredient inclusion levels (Lemos *et al.*, 2009; Tacon and Akiyama, 1997).

The *in vitro* pH-Stat assay used in this study appears suitable as a tool for assessing the effect of processing on particular plant protein ingredients, which is in agreement with studies with terrestrial animals (Rothenbuhler and Kinsella, 1985) and shrimp (García-Carreño *et al.*, 1997; Lemos and Tacon 2011). The *in vitro* DH results for the variously processed canola and soy products (e.g. meal, concentrate and isolate) mirrored the *in vivo* protein ADC results with correlation coefficients (*r*) of 0.90 and 0.99, respectively. It is well documented that the various processing stages from intact beans or seeds to de-hulled meals and ultimately the production of protein concentrates and isolates can significantly reduce the levels of poorly digestible non-protein components such as fibre, oligosaccharides, non-starch polysaccharides and phytic acid

(Storebakken *et al.*, 1998, 2000) and also inactivate protease inhibitors (Anderson and Wolf, 1995), all of which can negatively affect nutrient digestion in fish. As such, through an appropriate combination of physical, chemical and thermal processing, these anti-nutritional components are reduced, inactivated and/or the protein structures altered through thermal processing permitting higher protease activity on peptide bonds (García-Carreño *et al.*, 1997; Hsu *et al.*, 1977) and improved accessibility of protein to enzymatic hydrolysis. The mode of action of plant-based anti-nutritional factors in monogastric animals has been well studied and is through nutrient binding with bile salts and other anti-nutritional components (e.g., phytic acid, metal ions), obstruction of protease activity (proteolytic enzyme inhibition), accelerated movement of digesta through the intestinal tract and increased viscosity of digesta (Storebakken *et al.*, 1998, 2000; Refstie *et al.*, 1999; Francis *et al.*, 2001; Dendougui and Schwedt, 2004; Leenhouders *et al.*, 2006; Krogdahl *et al.*, 2010). As discussed earlier, the relationship between the level of processing of canola products (meal to concentrate) and soy products (meal to concentrate to isolate) used in this study with the *in vitro* protein DH was proportional. This result is in agreement with Dimes *et al.* (1994) who reported significantly reduced *in vitro* DH of casein when rainbow trout pyloric caeca enzymes were incubated with graded levels of soybean trypsin inhibitor (SBTI, 0-16 µM) representing those found in un-processed soy products. The results also agree with García-Carreño *et al.* (1997) who demonstrated increased *in vitro* DH of legume seed meals using shrimp hepatopancreas enzymes after thermal processing. Similar results have been reported on the beneficial effects of de-hulling and reduction of anti-nutritional factors in plant protein supplements when fed to rainbow trout during *in vivo* protein digestibility studies (Glencross *et al.*, 2007, 2010).

### *In vitro prediction of protein quality*

Most of the *in vitro* protein digestion studies with fish and crustaceans have subjected 'individual' test ingredients to the various enzyme cocktails and *in vivo* protein ADC studies typically determine digestion coefficients for 'single' test ingredients. Thus, the combination of these two methods may complicate the application of results to the feed industry for the following reasons: a) these *in vitro* enzyme studies do not take

into account the effect of other dietary nutrients and binders which can inhibit proteolytic enzyme activity *in vivo* (Yamamoto and Akiyama, 1995) and b) *in vivo* studies assume that the single ingredient digestion coefficients are always additive in the combined diet (Cho *et al.*, 1982); which is valid in many cases but may not be for ingredients having very high or very low digestibility (Tibbetts *et al.*, 2006). Due to these concerns and the complexity of *in vivo* food digestion, the complete reproduction of *in vivo* results through *in vitro* methods may be difficult (Bassompierre, 1997; Savoie, 1994).

The ultimate goal of determining the *in vitro* protein DH of feed ingredients is to utilize the data in conjunction with *in vivo* protein ADC values by generating a predictive equation(s). However, the generation of an 'all-inclusive' predictive regression equation may not be possible. It is likely that several predictive equations for each species are required according to the origin of feed ingredient, level of processing and relative digestibility as discussed by several authors (Pedersen and Eggum, 1983; Jaguelin *et al.*, 1994; Shipton and Britz, 2002; Lemos *et al.*, 2009). Specifically, Haard (1993) pointed out that *in vitro* pH-Stat assays may over-estimate protein quality of plant-origin ingredients relative to those of animal-origin for salmonids. This has also been documented for shrimp (Fernández Gimenez *et al.*, 2009), seabream (Alarcón *et al.*, 2002) and mammals (Marletta *et al.*, 1992). This is consistent with the findings of the present study where the DH of plant-origin ingredients were higher than those of animal-origin ingredients and this highlights the necessity for separate predictive equations for plant-origin and animal-origin feedstuffs (Table 4).

Measurement of *in vitro* DH by pH-Stat using enzymes from the pyloric caeca of farmed Atlantic cod provided results that were in general agreement with *in vivo* protein digestibility of many conventional and novel feed ingredients including of fish and poultry meals, soy-based products, wheat gluten and lupin meals, while ingredients containing high levels of chitin, ash and/or fibre were not as successful. In order to make *in vitro* DH data useful for research or industrial use it is necessary to combine these data with known *in vivo* protein quality data through the generation of predictive regression equations. For finfish, only one of these equations currently exists for rainbow trout (Dimes and Haard, 1994) while there are several equations for white shrimp (Ezquerria *et al.*, 1997, 1998; Lemos *et al.*, 2009). With the exception of Lemos *et al.* (2009), these

few published predictive equations are based on a small number of test feed ingredients (<10) providing data from a relatively static set of environmental conditions and have generated only a few small data sets and predominantly linear models. This is highly unlikely if the studies were conducted under natural environmental conditions of fish farms (e.g. culture conditions and nutritional history of donor animals) and a higher number and composition/quality range of test ingredients had been assayed (Bender 1982; Jørgensen, 1995). Indeed, this was the case reported by Lemos *et al.* (2009) who conducted extensive DH assays with shrimp hepatopancreas enzymes from various different culture conditions, enzyme batches and activities and using a large number (26) of test ingredients with a wide range of composition (28-99% crude protein, 0-20% fat, 0-47% carbohydrate, 0-49% ash) and *in vivo* protein digestibility (59-100% protein ADC). These authors found that non-linear models were required to describe the relationships between *in vivo* protein ADC and *in vitro* protein DH as was the case in this study (Table 4). To accurately 'model' this relationship and generate truly robust predictive equations for a particular species, data sets from numerous feed ingredients from a large number of processing conditions must be included in order to be adopted by the feed industry and researchers. At this stage, it would be wise for the aquaculture feed industry to learn from past mistakes associated with the human food and farm animal feed sectors. For example, many correlations between rapid-screening *in vitro* assays and *in vivo* performance have been made over the past century, only to be discredited once a wider range of samples were tested (Bender, 1982). Although the data generated in this study should provide the basis for further work, the current body of knowledge on gadoid nutrition needs additional research to develop more robust equations. As concluded for the salmonid work in the early 1990's (Dimes *et al.*, 1994) upon which these studies were based, seabream by Alarcón *et al.* (2002) and shrimp in the mid- to late 1990's (Ezquerria *et al.*, 1997; Lan and Pan, 1993), additional *in vivo* data are needed to establish a clear relationship between *in vitro* and *in vivo* assays for fish, including gadoids.

## Conclusions

Initial *in vivo* digestibility studies with juvenile gadoids indicated that the 'measured' *in vivo* protein digestibility coefficients (protein ADC) were very high

(>95%) for wheat gluten meal, soy protein concentrate, soy protein isolate and whole krill meal; high (85-95%) for herring meal, soybean meal, anchovy meal, pea protein concentrate, white lupin meal, crab meal, canola protein concentrate and corn gluten meal; mid-range (75-85%) for poultry by-product meal and canola meal; and low (<75%) for high ash shrimp meal, hydrolyzed feather meal and flaxseed meal. Using an enzyme fraction extracted from the pyloric caeca of farmed Atlantic cod, the *in vitro* degree of protein hydrolysis (protein DH) of these same feed ingredients was measured. Regression equations describing the relationship between *in vivo* protein ADC and *in vitro* protein DH provided good correlation (<4 percentage points difference) of protein ADC in most of the cases ( $r = 0.90-0.99$ ;  $R^2 = 0.88-0.99$ ), while some ingredients were either over- or under-estimated (6-7 percentage points) and appears to be related to high ash or chitin content ( $r = 0.75$ ;  $R^2 = 0.61$ ) and may indicate the need for an acid pre-hydrolysis stage and full account of non-protein nitrogen (NPN) content. The ‘predicted’ *in vitro* protein ADC were above 95% for wheat gluten meal, soy protein concentrate, soy protein isolate and whole krill meal; relatively high (85-95%) for soybean meal, white lupin meal, herring meal, anchovy meal, canola protein concentrate, pea protein concentrate and poultry by-product meal; mid-range (75-85%) for crab meal, shrimp meal and canola meal; and low (<75%) for hydrolyzed feather meal and flaxseed meal. Further research on development of a two-stage hydrolysis assay involving an acid (gastric) pre-digestion step prior to the assay presented may provide better agreement between *in vivo* protein ADC and *in vitro* protein DH and more robust predictive equations, specifically for farmed gadoids.

## **Acknowledgements**

We greatly acknowledge the significant scientific inputs of Joyce Milley, Adel El-Mowafi, Prabir Roy, Sandra Molas and Ryan Gibbs during the various method development phases of these studies. We thank Frank Powell and Kenneth Tibbetts for valuable assistance during tissue sample collection in the field. The critical review and valuable suggestions of Drs. Neil Ross and Stephen Ewart during preparation of this manuscript is greatly appreciated.

**Table 1**

Formulation and proximate composition of the basal diet (*as-fed* basis) used to measure *in vivo* apparent protein digestibility (ADC) of common and alternative feed ingredients.

Ingredient	(%)
Herring meal <sup>1</sup>	46-48
Wheat gluten meal <sup>2</sup>	5
CPSP-G <sup>3</sup>	5
Wheat middlings <sup>4</sup>	16.8-18.7
Whey powder <sup>5</sup>	7
Krill hydrolysate <sup>6</sup>	0-2 n
Corn starch (pre-gel) <sup>7</sup>	5.6-6.1
Vitamin mixture <sup>8</sup>	1.95
Mineral mixture <sup>8</sup>	1.95
Choline chloride <sup>9</sup>	0.3
Herring oil <sup>10</sup>	6.4-8.0
Proximate composition	
Moisture (%)	10.1±0.1
Crude protein (%)	47.9±2.5
Lipid (%)	13.0±1.3
Ash (%)	7.2±1.6
Carbohydrate <sup>11</sup> (%)	22.7±0.2
Gross energy (MJ/kg)	20.6±0.1

<sup>1</sup>St. Laurent Gulf Products Limited (Caraquet, NB, Canada)

<sup>2</sup>Roquette UK Limited (Northants, UK)

<sup>3</sup>Concentre proteique soluble de poisson (soluble fish protein concentrate) (Sopropêche, France)

<sup>4</sup>Dover Mills Limited (Halifax, NS, Canada)

<sup>5</sup>Farmers Co-operative Dairy (Truro, NS, Canada)

<sup>6</sup>SD-KH2, MaraVision Marine Products (Vancouver, BC, Canada)

<sup>7</sup>National Starch and Chemical Company (Bridgewater, NJ, USA)

<sup>8</sup>Vitamin and mineral premixes according to Tibbetts *et al.* (2004)

<sup>9</sup>USB Corporation (Cleveland, OH, USA)

<sup>10</sup>Corey Feed Mills Limited (Fredericton, NB, Canada)

<sup>11</sup>Calculated as 100 – (moisture + crude protein + lipid + ash)

**Table 2**

Proximate composition, gross energy content (*as-fed* basis) and *in vivo* apparent protein digestibility (ADC) of the reference and experimental diets used to determine *in vivo* apparent protein digestibility (ADC) of the conventional and alternative feed ingredients.

	Moisture (%)	Crude protein (%)	Ash (%)	Gross energy (MJ/kg)	<i>In vivo</i> protein ADC (diet) (%)
Reference	10.0-10.3	44.2-49.4	7.0-9.1	20.4-20.6	91.2-93.6
Herring meal	9.2-9.5	51.1-57.1	8.0-10.5	20.5-20.9	92.0-93.8
Anchovy meal	9.4	56.7	9.5	19.8	91.6
Whole krill meal	8.9	56.1	9.8	20.0	93.2
Crab meal	8.3-9.5	46.5-50.8	10.9-13.3	19.2-19.9	90.1-90.6
Shrimp meal	7.7-8.5	42.4-46.3	15.4-16.3	18.2-19.0	85.2-86.3
Poultry by-product meal	8.2	54.8	8.3	20.8	87.8
Hydrolyzed feather meal	8.3	59.9	6.0	21.1	78.2
Soybean meal	9.3-10.0	43.7-48.4	6.8-8.2	19.6-20.8	90.1-91.5
Soy protein concentrate	9.1	56.0	6.5	20.0	94.0
Soy protein isolate	9.4	61.1	6.4	20.6	92.8
Canola meal	8.8-9.0	41.0-46.9	7.1-8.2	19.8-20.5	87.3-90.4
Canola protein concentrate	8.3	54.2	8.1	20.0	89.9
Flaxseed meal	10.3	43.9	6.3	19.9	81.6
Pea protein concentrate	8.8	49.5	6.6	19.9	90.3
White lupin meal	9.0	45.6	6.0	20.0	90.8
Corn gluten meal	8.8-10.0	49.6-53.6	5.3-6.6	20.5-21.7	89.5-92.5
Wheat gluten meal	9.1	59.5	5.0	21.1	94.8



**Table 3** Proximate composition, gross energy content (*as-fed* basis) and *in vivo* apparent protein digestibility (ADC) of the conventional and alternative feed ingredients used to measure *in vitro* degree of protein hydrolysis (DH) using enzymes from pyloric caeca of Atlantic cod (*Gadus morhua*).

	International feed number	Moisture (%)	Crude protein (%)	Lipid (%)	Ash (%)	Carbohydrate <sup>a</sup> (%)	Gross energy (MJ/kg)	<i>In vivo</i> protein ADC (ingredient) (%)
<i>Fish meals</i>								
Herring meal <sup>b</sup>	5-02-000	7.1	74.5	10.1	10.4	0.0	20.8	93.3
Herring meal <sup>b</sup>	5-02-000	8.5	69.7	10.2	14.4	0.0	19.8	95.9
Anchovy meal <sup>c</sup>	5-01-985	7.8	68.3	9.6	15.8	0.0	19.1	92.2
<i>Zooplankton and crustacean by-product meals</i>								
Whole krill meal <sup>d</sup>	5-16-423	4.8	72.4	5.3	17.5	0.0	18.8	96.3
Crab meal <sup>e</sup>	5-01-663	9.1	54.0	5.7	22.7	8.4	15.8	89.4
Crab meal <sup>e</sup>	5-01-663	8.5	50.3	7.1	26.7	7.4	15.0	82.0
Shrimp meal <sup>f</sup>	5-04-226	6.2	37.2	3.5	38.4	14.7	12.4	66.7
Shrimp meal <sup>f</sup>	5-04-226	5.8	40.6	4.5	37.7	11.4	12.5	73.5
<i>Animal by-product meals</i>								
Poultry by-product meal <sup>g</sup>	5-03-798	5.0	66.3	14.6	10.8	3.3	22.0	80.2
Hydrolyzed feather meal <sup>g</sup>	5-03-795	5.8	83.5	7.9	3.8	0.0	22.7	62.4
<i>Oilseed meals</i>								
Soybean meal <sup>h</sup>	5-04-612	11.4	47.3	2.0	6.0	33.3	17.4	92.3
Soybean meal <sup>h</sup>	5-04-612	6.6	46.3	5.5	5.7	35.9	19.5	92.2
Soy protein concentrate <sup>i</sup>	5-08-038	7.9	68.7	0.3	5.1	18.0	19.0	98.6
Soy protein isolate <sup>i</sup>	–	7.6	85.6	4.4	4.5	0.0	21.2	97.4
Canola meal <sup>j</sup>	5-06-145	6.3	38.9	2.6	7.1	45.0	18.2	76.0
Canola meal <sup>j</sup>	5-06-145	11.4	38.3	3.8	6.9	39.6	18.2	83.0
Canola protein concentrate <sup>j</sup>	–	4.7	61.4	2.7	10.3	20.7	19.4	88.8
Flaxseed meal <sup>k</sup>	–	12.0	31.0	9.5	4.6	42.8	18.8	52.6

**Table 3 (Continued)** Proximate composition, gross energy content (*as-fed* basis) and *in vivo* apparent protein digestibility (ADC) of the conventional and alternative feed ingredients used to measure *in vitro* degree of protein hydrolysis (DH) using enzymes from pyloric caeca of Atlantic cod (*Gadus morhua*).

	International feed number	Moisture (%)	Crude protein (%)	Lipid (%)	Ash (%)	Carbohydrate <sup>a</sup> (%)	Gross energy (MJ/kg)	<i>In vivo</i> protein ADC (ingredient) (%)
<i>Pulse meals</i>								
Pea protein concentrate <sup>l</sup>	–	7.2	49.0	4.1	4.9	34.8	18.5	89.8
White lupin meal <sup>m</sup>	–	7.4	38.5	6.2	3.4	44.4	18.9	89.7
<i>Cereal grain meals</i>								
Corn gluten meal <sup>h</sup>	5-28-242	11.0	61.6	4.3	1.0	22.1	20.9	86.3
Corn gluten meal <sup>h</sup>	5-28-242	7.5	65.8	1.8	1.4	23.5	22.1	92.3
Wheat gluten meal <sup>n</sup>	5-05-220	7.4	79.3	1.9	0.5	10.9	22.6	99.9

<sup>a</sup> Calculated as 1000 – (moisture + crude protein + lipid + ash)

<sup>b</sup> Scotia Garden Seafood Incorporated (Yarmouth, NS, Canada)

<sup>c</sup> Sindicato SA, Grupo Sipesa (Lima, Peru)

<sup>d</sup> Aqion (Colorado Springs, CO, USA)

<sup>e</sup> St. Laurent Gulf Products Limited (Caraquet, NB, Canada)

<sup>f</sup> Island Fisherman's Co-Op (Lemeque, NB, Canada)

<sup>g</sup> Rothsay (Dundas, ON, Canada)

<sup>h</sup> Bunge Canada (Oakville, ON, Canada)

<sup>i</sup> Soycomil<sup>®</sup> and Pro-Fam<sup>®</sup>, respectively; Archer Daniels Midland (Decatur, IL, USA)

<sup>j</sup> MCN BioProducts Incorporated (Saskatoon, SK, Canada), Canbra Foods (Lethbridge, AB, Canada)

<sup>k</sup> Bioriginal Food and Science Corporation (Saskatoon, SK, Canada)

<sup>l</sup> Parrheim Foods (Portage La Prairie, MB, Canada)

<sup>m</sup> Alberta Department of Agriculture (AB, Canada)

<sup>n</sup> Roquette UK Limited (Northants, UK)

**Table 4** Correlation coefficients ( $r$ ) of the relationship between *in vivo* apparent protein digestibility (ADC) and *in vitro* degree of protein hydrolysis (DH) and coefficients of determination ( $R^2$ ) of various predictive models of feed ingredients fed to juvenile gadoids.

Ingredients used in model	$r$	$R^2$			
		Linear	Log	Power	Exponential
All (n=21)	0.58	0.33	0.32	0.28	0.29
Animal-origin (n=10)	0.66	0.43	0.47	0.46	0.42
Fish and poultry (n=5)	0.94	0.89	0.86	0.89	0.92 *
Zooplankton and crustacean (n=5)	0.75	0.57	0.61 *	0.57	0.53
Plant-origin (n=11)	0.58	0.34	0.26	0.23	0.29
Oilseed (n=8)	0.80	0.64	0.74	0.70	0.59
Soy (n=4)	0.99	0.99	0.99	0.99	0.99 *
Canola and flax (n=4)	0.90	0.80	0.88 *	0.85	0.77
Pulse and grain (n=3)	0.96	0.92 *	0.80	0.80	0.92

\* Predictive regression equations

Fish and poultry (Exponential)	Predicted <i>in vivo</i> protein ADC = 51.995 <sup>(0.046[in vitro DH])</sup>	$R^2 = 0.92$
Zooplankton and crustacean (Log)	Predicted <i>in vivo</i> protein ADC = 28.772Ln( <i>in vitro</i> DH) + 40.626	$R^2 = 0.61$
Soy (Exponential)	Predicted <i>in vivo</i> protein ADC = 83.071 <sup>(0.008[in vitro DH])</sup>	$R^2 = 0.99$
Canola and flax (Log)	Predicted <i>in vivo</i> protein ADC = 54.963Ln( <i>in vitro</i> DH) – 63.321	$R^2 = 0.88$
Pulse and grain (Linear)	Predicted <i>in vivo</i> protein ADC = 0.723( <i>in vitro</i> DH) + 84.377	$R^2 = 0.92$

**Table 5**

*In vitro* degree of protein hydrolysis (DH), *in vivo* apparent protein digestibility (measured vs. predicted) and prediction residuals (predicted protein ADC – measured protein ADC) of animal-origin feed ingredients<sup>a</sup> fed to juvenile gadoid fish.

	Enzyme activity <sup>b</sup>		<i>In vitro</i> DH (%)	Protein ADC		Residual
	(U/μL)			Measured	Predicted	
	Trypsin	Chymotrypsin		<i>In vivo</i>	<i>In vitro</i>	
<i>Fish meals</i>						
Herring meal (70-74%) <sup>c</sup>	0.46±0.01 <sup>ns</sup>	2.8±0.08 <sup>ns</sup>	12.2±0.3 <sup>c</sup>	94.6	91.2	-3.4
Anchovy meal (68%)	0.46±0.00	2.8±0.00	12.3±0.1 <sup>c</sup>	92.2	91.5	-0.7
<i>Zooplankton and crustacean by-product meals</i>						
Whole krill meal (72%)	0.45±0.01	2.9±0.03	7.3±0.3 <sup>b</sup>	96.3	98.0	+1.7
Crab meal (50-54%)	0.46±0.00	2.9±0.04	3.8±0.6 <sup>a</sup>	85.7	78.8	-6.6
Shrimp meal (37-41%)	0.47±0.03	2.9±0.01	3.4±0.5 <sup>a</sup>	70.1	76.1	+6.0
<i>Animal by-product meals</i>						
Poultry by-product meal (66%)	0.48±0.00	2.9±0.01	11.3±0.7 <sup>c</sup>	80.2	87.3	+7.1
Hydrolyzed feather meal (83%)	0.48±0.00	2.7±0.07	3.7±0.1 <sup>a</sup>	62.4	61.8	-0.6

<sup>a</sup> Mean ± SE (n=3); values within the same column with different superscript letters are significantly different (P<0.05)

<sup>b</sup> Measured enzyme activity of pyloric caeca-derived enzymes fractions

<sup>c</sup> Values in brackets indicate the crude protein content (% *as fed* basis) of the test ingredients

<sup>ns</sup> no significant differences (P>0.05) within column

**Table 6**

*In vitro* degree of protein hydrolysis (DH), *in vivo* apparent protein digestibility (measured vs. predicted) and prediction residuals (predicted protein ADC – measured protein ADC) of plant-origin feed ingredients<sup>a</sup> fed to juvenile gadoid fish.

	Enzyme activity <sup>b</sup>		<i>In vitro</i>	Protein ADC		Residual
	(U/ $\mu$ L)			DH (%)	Measured	
	Trypsin	Chymotrypsin	<i>In vivo</i>		<i>In vitro</i>	
<i>Oilseed meals</i>						
Soybean meal (46-47%) <sup>c</sup>	0.48 $\pm$ 0.02 <sup>ns</sup>	2.7 $\pm$ 0.08 <sup>ns</sup>	13.3 $\pm$ 0.3 <sup>bc</sup>	92.3	92.4	+0.1
Soy protein concentrate (69%)	0.45 $\pm$ 0.00	3.0 $\pm$ 0.09	21.5 $\pm$ 2.4 <sup>d</sup>	98.6	98.7	+0.1
Soy protein isolate (86%)	0.45 $\pm$ 0.00	2.9 $\pm$ 0.10	20.7 $\pm$ 0.1 <sup>d</sup>	97.4	98.0	+0.6
Canola meal (38-39%)	0.45 $\pm$ 0.01	2.8 $\pm$ 0.16	12.5 $\pm$ 0.7 <sup>bc</sup>	79.5	75.4	-4.1
Canola protein concentrate (61%)	0.46 $\pm$ 0.00	2.9 $\pm$ 0.05	17.2 $\pm$ 0.4 <sup>cd</sup>	88.8	93.0	+4.2
Flaxseed meal (31%)	0.46 $\pm$ 0.01	3.0 $\pm$ 0.02	8.9 $\pm$ 0.2 <sup>ab</sup>	52.6	56.5	+3.9
<i>Pulse meals</i>						
Pea protein concentrate (49%)	0.46 $\pm$ 0.00	3.0 $\pm$ 0.02	5.6 $\pm$ 0.5 <sup>a</sup>	89.8	88.5	-1.3
White lupin meal (38%)	0.46 $\pm$ 0.01	2.9 $\pm$ 0.01	10.0 $\pm$ 0.7 <sup>ab</sup>	89.7	91.6	+1.9
<i>Cereal grain meals</i>						
Corn gluten meal (62-66%)	0.47 $\pm$ 0.00	2.9 $\pm$ 0.01	nd	89.3	-	-
Wheat gluten meal (79%)	0.46 $\pm$ 0.00	3.0 $\pm$ 0.07	20.7 $\pm$ 2.2 <sup>d</sup>	99.9	99.4	-0.5

<sup>a</sup> Mean  $\pm$  SE (n=3); values within the same column with different superscript letters are significantly different (P<0.05)

<sup>b</sup> Measured enzyme activity of pyloric caeca-derived enzymes fractions

<sup>c</sup> Values in brackets indicate the crude protein content (% *as fed* basis) of the test ingredients

<sup>ns</sup> no significant differences (P>0.05) within column



# Chapter 7

## General Discussion

## **Dietary protein and energy sources**

One of the primary research goals of this thesis was to examine the digestive capacity of farmed juvenile gadoids when fed conventional or alternative (novel) feed ingredients, using a combination of *in vivo* methods (**Chapters 2 and 3**) and *in vitro* methods (**Chapters 5 and 6**). After determination of the macronutrient composition of feed ingredients, these methods are typically the next step to understand dietary protein and energy utilization by fish. Considering both *in vivo* measured protein and energy apparent digestibility (ADC) and *in vitro* predicted protein ADC data, it was clear that gadoids have a high capacity to utilize a wide variety of dietary feed ingredients such as fish meals (herring meal and anchovy meal), zooplankton meal (whole freeze-dried krill), soy products (protein meal, concentrate and isolate) and wheat gluten meal with very high protein and energy ADC values of 90-100% and 86-96%, respectively. Other feed ingredients that may have considerable potential for use in gadoid feeds include pulse meals (pea protein concentrate and white lupin meal), corn gluten meal and canola protein concentrate with relatively high protein and energy ADC values of 84-93% and 75-83%, respectively. Due to high levels of poorly digestible components (e.g. chitin, ash, fiber, carbohydrates and keratin protein), poultry meals (poultry by-product meal and hydrolyzed feather meal), crustacean meals (crab and high-ash shrimp meal), canola meal and flaxseed meal may have limited value as feed ingredients in gadoid diets with poor protein ADC values of 53-89% and energy ADC values of 29-83%. It should be noted that there is some discrepancy with regard to the nutrient utilization from crustacean meals between gadoids in these studies and other marine species reported in the literature. The discrepancy is certainly due to the unusually high ash content (>38%) of the shrimp meal sample used in these studies relative to other studies at 18–27% (Hardy 1996; NRC 2011). In addition, the present studies showed a relatively high nutrient utilization of crab meal *in vivo* but this was not reflected *in vitro* and will be discussed further. As a result, the nutritional value of crustacean meals by gadoids should be re-examined with additional sources of crab and shrimp meals.

Digestibility of dietary macronutrients by farmed gadoids fed formulated feeds has received some attention recently (Hemre *et al.* 1989, 2003; Førde-Skjærvik *et al.* 2006; Kim *et al.* 2006, 2007; Refstie *et al.* 2006). However, with the exception of Kim *et*



*al.* (2006, 2007) that only examined two common feed ingredients (herring and soybean meal), all of these previous studies have been limited to work on ‘complete feeds’ and have exclusively used manual stripping or dissection to obtain fecal samples. The *in vivo* digestibility data presented in this thesis (**Chapters 2 and 3**) is unique because it is the only body of work with farmed gadoids that has examined the macronutrient digestibility of ‘individual feed ingredients’. This provides essential data that is required for least-cost ration formulations and the effective substitution of dietary feed ingredients. In addition, these studies used sedimentation columns for fecal collection, which is generally considered to be more appropriate and accurate than other methods (Cho *et al.* 1982). Manual stripping and dissection to obtain fecal samples from fish have been criticized because they underestimate nutrient digestibility (Hajen *et al.* 1993; Kabir *et al.* 1998; Storebakken *et al.* 1998; Vandenberg and de la Noüe 2001) due to incomplete digestion and fecal contamination with non-dietary components of endogenous origin (blood, urine, semen, sloughed intestinal cells). In addition, these methods subject the fish to considerable handling stress and potential physical damage (manual stripping) and death (dissection). Specifically, the internal anatomy of gadoids have a fold in the mid-section of the abdomen, unlike salmonids, that make manually stripping difficult, requiring additional pressure on the abdomen that can result in significant stress, injuries and contaminated fecal samples (Førde-Skjærvik *et al.* 2006; Roy *et al.* 2004). In contrast, fecal samples collected from properly designed settling columns, such as those designed for these studies (**Chapters 2 and 3**), allow for collection of uncontaminated samples from actively feeding, free-swimming fish that are naturally voided from the animal without stressful fish handling.

### **Digestible protein/digestible energy ratio**

Protein bioavailability through *in vivo* and *in vitro* methods is a critical step to assess the protein quality of feed ingredients and complete feeds for fish. However, the ultimate assessment of protein quality is through biological evaluation with the target species involving growth and nutrient metabolism studies (Bender 1982). This thesis addressed this area by documenting the growth potential and nutrient utilization efficiency of gadoid fish at the juvenile grower phase using varying levels of dietary

macronutrients (**Chapter 4**) which could not have been accurately done without an initial *in vivo* digestibility study (**Chapter 2**). The range of digestible protein/digestible energy (DP/DE) ratios examined in these studies was within the range (22–33 g DP/MJ DE) reported to promote high protein gains in other juvenile fish species such as rainbow trout, Atlantic halibut, Atlantic cod and gilthead seabream (Lie *et al.* 1988; Cowey 1992; Aksnes *et al.* 1996; Lupatsch *et al.* 2001). After 63 days of feeding, fish receiving all experimental diets achieved over 400% growth and over 98% survival indicating that juvenile gadoids have excellent potential for rapid growth on formulated diets. In particular, these studies demonstrated that a dietary DP/DE ratio of no less than 28.5 g DP/MJ DE promotes the highest growth rates (>2.4%/day) of juvenile (<100 g) gadoids. This level of growth performance is similar to those reported for other marine fish such as juvenile European sea bass (2.3%/day) of similar size (Peres and Oliva-Teles 1999). The macronutrient utilization data presented in **Chapter 4** also revealed that the weight gain observed in the fish was regulated solely by increasing levels of dietary protein in a linear manner and was independent of dietary lipid level or DP/DE ratio. Likewise, the feed conversion ratios (FCR) of the fish were solely affected by dietary protein content rather than dietary lipid level or DP/DE ratio.

Since protein efficiency ratio (PER) is generally regulated by the non-protein energy input of the diet, PER is a good measure of the ‘protein-sparing effect’ of dietary lipid and/or carbohydrate (Lie *et al.* 1988). In these studies, there were no significant differences in PER between the experimental diets with the exception of the lowest DP/DE ratio (24.7 g DP/MJ DE) which was significantly higher than all other diets. All of these results indicate that when dietary protein is adequate, haddock preferentially use protein as the prime dietary energy source. This result from **Chapter 4** using haddock confirms this situation for commercially important gadoids as it is also consistent with previous results with Atlantic cod (Lie *et al.* 1988; Morais *et al.* 2001). These results provide further evidence for the case that the opportunity for protein sparing in gadoids diets is very limited and that only when dietary protein is limited (e.g. below requirement), does dietary lipid have some ability to spare dietary protein, possibly at the expense of growth rate. This nutritional constraint has also been reported for European sea bass (Dias *et al.* 1998).

Juvenile gadoids, like other marine fish, efficiently utilize single feed ingredients and ‘complete’ feeds formulated with multiple feed ingredients. High protein and energy digestibilities (>90% and >80%, respectively) are achievable in juvenile gadoids when the fish are provided with nutritionally complete feeds formulated with high quality feed ingredients (**Chapters 2, 3 and 4**). These studies demonstrated that dietary carbohydrate content has little effect on protein digestibility which is in agreement with other farmed marine species such as Atlantic halibut (Grisdale-Helland and Helland 1998), salmonids (Aksnes 1995; Hemre *et al.* 1995; Grisdale-Helland and Helland 1997) and European sea bass (Peres and Oliva-Teles 1999). Alternatively, significant differences were observed with respect to energy digestibility given different feed formulations. Since the energy content of a diet is supplied by the catabolism of protein, lipid and carbohydrate and differences in protein digestibility measured in **Chapter 4** were negligible, the significant differences in energy digestibility observed must be attributed to either lipid or carbohydrate content, or a combination of both. In the experimental diets used in **Chapter 4**, with a decrease in protein from 55 to 45% and lipid from 16 to 11%, the dietary carbohydrate content increased from 12 to 28%. The decreasing energy digestibility observed was significantly correlated to increasing dietary carbohydrate content but lipid content had no effect. Lie *et al.* (1988) suggested that dietary carbohydrate should not exceed 17% for juvenile Atlantic cod and data presented in **Chapter 4** now confirms this as well for juvenile haddock where energy digestibility was significantly reduced in all diets containing carbohydrate levels in excess of 17%.

Unlike salmonids, gadoids accumulate excess dietary lipid in the liver, resulting in enlarged livers and a high hepatosomatic index (HSI). This has been well demonstrated for both Atlantic cod and haddock (Lie *et al.* 1986, Dos Santos *et al.* 1993, Nanton *et al.* 2001). Further studies have shown that the primary causes of this condition in gadoids are a low capacity for lipoprotein transport from the liver to the muscle cells and limited catabolic activity ( $\beta$ -oxidation) of lipid in the liver (Nanton *et al.* 2003). Although liver function may not be impaired by this condition (Morais *et al.* 2001; Nanton 2002), it is considered undesirable from a fish metabolism perspective. Fish with enlarged livers inefficiently utilize dietary energy resulting in lower somatic tissue growth as a percentage of whole-body weight gain than fish with smaller livers and this

condition can also be stressful to the fish. Thus, minimizing the HSI or ‘fatty liver’ condition in cultured gadoids is of economic importance. Earlier reports suggest that it is excessive dietary lipid levels that promote this enlarged liver condition. However, the results presented in **Chapter 4** demonstrate that it was both dietary protein and lipid levels that had significant effects on liver growth in haddock, as HSI values increased in step with increasing protein and lipid levels. This result for haddock is in agreement with reports on Atlantic cod (Jobling *et al.* 1991) suggesting that the accumulation of liver lipid is not only dependent upon total dietary lipid content but its interaction with other nutrients causing an aberration in lipid metabolism. Clearly, the dietary carbohydrate also plays a role in the results observed in the literature for cod and in **Chapter 4** for haddock since excess dietary energy is not only stored as lipid but also as liver glycogen. In fact, the combination of the energy-yielding nutrients (defined by the DP/DE ratio) when fed to haddock was the most strongly correlated variable with HSI values measured in the studies presented in **Chapter 4** (e.g. as DP/DE ratio decreases, HSI correspondingly increases). This strong inverse relationship has also been documented in sharpsnout seabream, *Diplodus puntazzo* (Hernández *et al.* 2001). These studies demonstrated that a minimum DP/DE ratio of 29.3 g DP/MJ DE is required to ensure juvenile haddock have a liver HSI under 9%, which corresponds to a diet containing minimum 50% protein and 11% lipid. This result is consistent with preliminary studies using isocaloric diets (Kim and Lall 2001; Kim *et al.* 2001; Nanton *et al.* 2001) which demonstrated that high growth rates and minimal HSI can be achieved in juvenile fish fed 50-55% protein and <12% lipid, but also suggests a maximum carbohydrate inclusion of 17%.

The various levels of dietary protein (45-55%) and lipid (11-16%) used in **Chapter 4** had highly significant effects on final whole-body (WB) energy retention. That is, within each dietary lipid level, increasing dietary protein from 45 to 55%, led to significant increases in WB energy gain and within each dietary protein level, increasing dietary lipid from 11 to 16% also led to significantly higher WB energy gains. The end result was that the diet containing the highest levels of both dietary protein and lipid (28.5 g DP/MJ DE) resulted in juveniles with the highest WB energy gain, which is also documented for juvenile European sea bass (Lanari *et al.* 1999). This high energy

retention efficiency (>45%) is higher than that reported previously for juvenile haddock (43%) (Kim and Lall 2001) using isocaloric diets so it is likely the result of a more appropriate DP/DE ratio. However, it cannot be concluded that this particular DP/DE ratio is optimum because one of the goals of farming fish is to produce marketable fish products containing high levels of protein, which is in the form of the fillet flesh and not other components like viscera and liver. As discussed, all diets containing less than 29.3 g DP/MJ DE (e.g. 16% lipid) produced juveniles with enlarged livers (>11% HSI). These enlarged livers, being high in lipid, contributed considerable amounts of energy to the WB energy content, so it is an undesirable portion of the WB energy gain as it currently has no commercial value and will ultimately be discarded during processing. The highest nitrogen gains (>1.2 g/fish) were achieved when the DP/DE ratio was 28.5 and 30.2 g DP/MJ DE as a result of high nitrogen retention efficiency (>40%) of fish being fed these diets. To discriminate between these two potential optimum DP/DE ratios, studies in **Chapter 4** determined the ‘composition’ of the energy gain according to Rodehutschord and Pfeffer (1999). The results showed that in juveniles fed the 28.5 g DP/MJ DE diet, the gains were predominantly due to a build-up of energy in the form of lipid (>100 kJ/fish), particularly liver lipid. In contrast, juveniles fed the 30.2 g DP/MJ DE diet had significantly lower and more acceptable levels of energy retained as lipid (<85 kJ/fish), relative to that retained as the more desirable protein energy (>180 kJ/fish). The energy retained in the form of protein was highly regulated by the dietary protein content whereas energy retained as lipid was highly regulated by both dietary lipid and digestible energy levels. The overall conclusions from the data presented in **Chapter 4** were that in order to ensure not only maximum growth rate (>2.4%/day) but also highest digestibility of organic matter (>80%), protein (>93%) and energy (>85%), maximum nitrogen and energy retention efficiency (>40 and >45%, respectively), low energy retention in the form of liver lipid (<100 kJ/fish) and minimal excessive liver growth and reasonable HSI (<10%), a diet for farmed gadoids during the juvenile grower phase must contain 30.2 g DP/MJ DE. Practically, this requirement can be met in a commercial feed formulation containing 55% crude protein, 11% fat and 16% carbohydrate. The studies presented in **Chapter 4** were conducted with juvenile haddock based on real measured nutrient ADC values of feed ingredients measured in **Chapter 2**. The goal was to

improve the understanding of juvenile haddock nutrition and also to confirm the suspected similarities between both gadoid species. The recommended juvenile diet formulation for haddock discussed above closely agrees with previous recommendations for Atlantic cod (54% protein and >17% carbohydrate) and initial studies with haddock (50–54% protein and >12% lipid).

## **Dietary protein quality – *In vitro* evaluation**

### *Method development*

A major goal of this thesis was to develop and assess the potential of an *in vitro* pH-Stat method for rapid screening of the protein quality of feed ingredients, specifically for farmed gadoids (**Chapters 5 and 6**). Current methods for finfish are highly variable, have poor repeatability and use pyloric caeca-derived digestive enzymes from sources other than the target species, and therefore required a novel approach to study ‘gadoid-specific’ nutritional development (**Chapter 5**). The pyloric caeca in gadoids is relatively small in size compared to other fish species, representing only about 5% of the total digestive tract length and 1.5% of the fish body weight. The pylorosomatic index (PSI) reported for the farm-raised Atlantic cod used in these studies (1.4%) is much lower than that of rainbow trout which is 2.8-3.8% (Bassompierre *et al.* 1998b). However, due to the very large number of blind diverticula or caecal ‘fingers’ present in gadoids (222) relative to the less than 60 for most other species including rainbow trout, the multiple foldings contained within the pyloric caeca in gadoids increases the gut surface area to such an extent that it makes it a larger site of digestion than all of the remaining regions of the alimentary tract combined (Buddington *et al.* 1986; 1987). As such, the pyloric caeca of gadoids likely accounts for more than 70% of total enzymatic digestion, making it the most suitable digestive tissue for *in vitro* protein hydrolysis studies.

In the first part of **Chapter 5**, the two major alkaline protease enzymes were successfully concentrated through various extraction and partial purification steps. Each step was performed to enrich the total concentration of the target enzymes being followed in the enzyme fraction (e.g. trypsin and chymotrypsin) which have similar molecular weights of 24.2 and 26.2 kDa, respectively (Ásgeirsson *et al.* 1989; Ásgeirsson and Bjarnason 1991; Raae and Walther 1989). These target enzymes were selected as

‘marker’ enzymes because they have been clearly shown to constitute the major enzymes produced by the pancreatic cells for proteolytic function in the pyloric caeca of gadoids and other coldwater marine species. Large increases in enzyme activities (trypsin, 408%, chymotrypsin, 1270%) were measured throughout the extraction steps indicating that the extraction procedure was successful in concentrating these enzymes. The trypsin and chymotrypsin activity levels in the final extracts were  $0.50 \pm 0.01$  and  $3.05 \pm 0.15$  U/ $\mu$ g protein, respectively while the final blank fractions were confirmed to have no proteolytic activity. When reviewing the literature with respect to digestive enzyme activities of fish, the only consistency is the overwhelming lack of consistency; making comparisons very difficult. Reported values for fish pyloric caeca enzyme extracts processed at similar levels are highly variable due to species differences, nutritional history, culture conditions of donor fish, extraction/purification techniques and different activity assay conditions (e.g. different substrates, incubation temperature and/or pH, method of calculation, reporting units, etc.) (Alarcón *et al.* 1995 ; Hidalgo *et al.* 1999; Pérez-Jiménez *et al.* 2009).

The method development studies reported in **Chapter 5** also involved running a ‘procedural blank’ to account for background protein hydrolysis that occurs for non-enzymatic reasons (eg. stirring motion, hydration, atmospheric gases, pH-probe fluctuations, etc.). During early *in vitro* studies, Pedersen and Eggum (1983) assumed that measuring non-enzymatic hydrolysis was not necessary and would not increase the agreement between *in vitro* and *in vivo* results, while Alarcón *et al.* (2002) proved that this assumption was incorrect by demonstrating that non-enzymatic hydrolysis can be highly variable between samples and may account for a significant amount of total protein hydrolysis (>35%). Pedersen and Eggum (1983) pointed out that *in vivo* digestion is a combination of both enzymatic hydrolysis and non-enzymatic hydrolysis; however, several authors have demonstrated better agreement between *in vivo* and *in vitro* results when non-enzymatic hydrolysis was accounted for. The research presented in **Chapters 5 and 6** is the first time a procedural blank has been used to account for non-enzymatic hydrolysis, whereas previous studies with salmonids, other marine fish and shellfish have either used distilled water or no blank at all.

A major objective of **Chapter 5** was to determine the most appropriate protein substrate concentration [S] to use during pH-Stat assays. This was an important step because the [S] used in various studies in the literature with aquatic animals is quite variable (1-2 mg of N per mL of solution) and the reason for this range was not entirely clear. This was troubling from the stand-point of method development because the [S] should surely affect the degree of hydrolysis (DH) under the variable assay durations used in the literature, even for the same test ingredient. An interesting finding of Wei and Zhimin (2006) demonstrated its significant effects on protein hydrolysis rate and final DH by varying the [S] (0.3-2.4 mg/mL) using purified trypsin as the enzyme and bovine serum albumin (BSA) as the protein substrate. It would appear that the use of a 1-2 mg N/mL [S] may have originated from the work of Hsu *et al.* (1977) and Maga *et al.* (1973) using an *in vitro* pH-Shift method with laboratory rats. In these studies, a high correlation between *in vitro* DH and *in vivo* protein digestibility was achieved within 3-10 minutes using 1-2 mg N/mL solution. Subsequent studies with aquatic animals appear to have adopted these [S] as the standard. Researchers working with salmonids, sparids, tuna, shrimps and abalone have used [S] in the range of 0.7 to 1.6 mg N/mL given differences in protein content and proteolytic activity of their enzyme fractions (Alarcón *et al.* 1998; Carter *et al.* 1999; Córdova-Murueta and García-Carreño 2002; Dimes and Haard 1994; Dimes *et al.* 1994a; Ezquerra *et al.* 1997, 1998; García-Carreño *et al.* 1997; Lan and Pan 1993; Shipton and Britz, 2002). However, these studies did not attempt to optimize the [S] for the assay. Only Alarcón *et al.* (1998, 2002) working with seabream assessed the effects of varying [S] on DH. Direct adoption of the procedures of Hsu *et al.* (1977) and Maga *et al.* (1973) is not appropriate for aquatic animal studies since rats are warm-blooded endothermic animals and, as such, these studies were conducted at higher temperatures (37°C) than have been used in the literature for ectothermic shellfish (25-30°C) and finfish (15-25°C). In particular, digestive enzymes from gadoids, used in **Chapters 5 and 6**, have been shown to be highly efficient at lower temperatures and different pH levels compared to endothermic animals (Gudmundsdóttir and Pálsdóttir 2005; Haard 1992; Hazel and Prosser 1974; Jóhannsdóttir 2009; Shahidi and Kamil 2001; Simpson *et al.* 1990; Simpson and Haard 1984, 1987; Squires *et al.* 1986). In addition, Hsu *et al.* (1977) and Maga *et al.* (1973) did not use a prepared enzyme extract fraction



from the digestive tract of rats; rather they used a mixture of commercially available, high-activity purified enzymes (trypsin, chymotrypsin, peptidase).

The work presented in **Chapter 5** was largely based on pioneering method development studies for salmonids that used vitamin-free casein as the test protein source (Dimes and Haard 1994). The results using Atlantic cod enzymes were in agreement with the relevant literature for salmonids. Casein DH achieved in **Chapter 5** (23-26%) was similar to the range reported for salmonids (23-27%; Dimes and Haard 1994; Dimes *et al.* 1994a) upon which this work was based. The data presented in **Chapter 5** demonstrated that the same DH can be achieved in a shorter period of time using an optimized [S]. Plots of [S] versus assay duration (minutes) and titrant volume required (mL) showed significant linear relationships ( $R^2=0.85-0.99$ ), demonstrating the high proportionality between [S] and both assay duration and titrant consumption. As a result of these findings, a [S] of 0.5 mg N/mL was recommended for subsequent DH studies (**Chapter 6**) based on the curve progression over 10 hours having a rapid increase initially and then leveling off at maximum DH (26%) in a moderate assay duration (~6 hours) with minimal use of titrant (<12 mL). This was also supported by comparing slopes of the linear portion ( $R^2>0.99$ ) of each hydrolysis curve over the first 90 minutes. The most rapid proteolysis occurred at a [S] of 0.5 mg N/mL (>0.18), whereas the activity rates fell to <0.12 at [S] of 0.75 and 1 mg N/mL. This result supports that of Rothenbuhler and Kinsella (1985) working at 37°C with purified enzymes and various protein substrates (sodium caseinate, bovine serum albumin and defatted soy protein). They found the optimum [S] to be 3 mg protein/mL, when expressed in terms of nitrogen (N/P conversion factors of 6.38 for sodium caseinate and 6.25 for bovine serum albumin and defatted soy protein) equals 0.47 and 0.48 mg N/mL, respectively.

A secondary goal of studies in **Chapter 5** was to assess the stability, in terms of protein concentration and proteolytic activity, of the enzyme fractions stored at -20 and -80°C over a period of 12 months. The results provided important quality-control information for these studies and also for future studies with respect to the thermal stability or usable “shelf-life” of enzyme fractions produced in the manner described in **Chapter 5**. The enzyme fractions produced were extracted and stored in Tris/NaCl and sodium phosphate solutions in polypropylene cryogenic vials without an anti-microbial

additive and were only thawed once. Results from this part of the study (**Chapter 5**) have demonstrated that under these conditions, the enzymes were very stable with the protein content remaining relatively constant over 12 months at storage temperatures of -20 and -80°C and the trypsin activity showing no significant change over 10 months, having retained over 94% of initial activity. Although there was a significant loss by 12 months (83% of initial activity) when stored at -80°C, there was no significant difference relative to those stored at -20°C over the same period of time. At -80°C, the chymotrypsin after 12 months storage showed no significant loss of activity and retained 88% of initial activity. However, when stored at -20°C, chymotrypsin showed a significant loss of activity after 8 months (70% of initial activity). As a final quality control check, the results of DH of vitamin-free casein was compared using fresh enzyme fractions ( $T_{0 \text{ months}}$ ) versus ones stored for 12 months at -80°C ( $T_{12 \text{ months}}$ ). The DH was statistically the same ( $P=0.839$ ) at  $23.5\pm 1.8\%$  and  $23.3\pm 0.5\%$ , respectively. Based on these results, it was recommended that enzyme fractions produced by the methods detailed in **Chapter 5** be stored at -80°C and used within 8-10 months.

### *Application to common and alternative ingredients*

Using enzyme fractions isolated from the pyloric caeca of Atlantic cod according to the methods in **Chapter 5**, the *in vitro* degree of protein hydrolysis (DH) of the same feed ingredients used during *in vivo* protein ADC studies (**Chapter 2 and 3**) were measured by an *in vitro* closed-system pH-Stat assay (**Chapter 6**). The ingredients represented a wide range of available feed ingredients either in use or being considered for use in gadoid diets in Canada with highly variable compositions (31-86% crude protein, 0.3-15% lipid, 0.5-38% ash, 0-45% carbohydrate, 12-23 MJ/kg gross energy) providing a large variation in *in vivo* measured protein ADC of 50-100% (**Chapter 2 and 3**). The work presented in **Chapter 6** is the first time that these *in vitro* protein hydrolysis methods have been applied to gadoid species. Because of the technical difficulties inherent with the pH-Stat procedure, successful use of the methods with aquatic animals is rare and to date have only been adequately demonstrated a few times with non-gadoid finfish and shrimps (Dimes and Harrod 1994; Ezquerro *et al.* 1997, 1998; Alarcón *et al.* 2002; Lemos *et al.* 2009). The work presented in **Chapter 6** should add to

the much-needed body of knowledge on the application of the *in vitro* pH-Stat assay as a tool for nutritional development for aquatic animals, in particular the rapid-screening of potential feed ingredients.

For animal-origin feed ingredients, the *in vitro* DH values were highest (11-12%) for poultry by-product meal, herring meal and anchovy meal, mid-range (7%) for whole krill meal; and lowest (3-4%) for crab meal, shrimp meal and hydrolyzed feather meal. These *in vitro* DH results were in good agreement with *in vivo* protein ADC data for fish meals and poultry meals (**Chapters 2 and 3**) that also showed relatively high protein ADC for herring, anchovy and poultry by-product meals and low protein ADC for hydrolyzed feather meal. The *in vitro* DH results for zooplankton and crustacean meals, however, indicated lower digestibility than those using *in vivo* protein ADC methods (**Chapters 2 and 3**). For the zooplankton and crustacean meals, the total amount of intact protein was likely over-estimated because of a relatively higher proportion of N in the form of NPN. Zooplankton and crustacean feed ingredients may contain significant levels of chitin (10-20%) and free amino acids (>2%) (Hertrampf and Piedad-Pascual 2000; Heu *et al.* 2003). In addition, it is possible that the krill and crustacean products used in this study may have retained some endogenous enzyme activity that may be rapidly triggered causing partial post-mortem protein hydrolysis after capture at sea (within 6-8 hours) prior to final processing (Kolakowski 1986) resulting in elevated levels of NPN (e.g. volatile bases, trimethylamine, free amino acids, peptides, ammonia). Various authors have reported that freshly harvested krill and crustaceans with NPN levels of less than 10 g N/100 g can exceed 50 g N/100 g within 24 hours (Kolakowski 1986; Fagbenro and Bello-Olusoji 1997; Heu *et al.* 2003). If this were the case, these products would have a comparatively high content of NPN that may not affect apparent *in vivo* protein ADC (since it is based on N ratios between diet and faeces) (**Chapters 2 and 3**) but could influence *in vitro* protein DH (**Chapter 6**) if the specific enzyme cleavage sites along those polypeptides (during *in vitro* protein hydrolysis) have previously been cleaved (Córdova-Murueta and García-Carreno, 2002). The implication of these scenarios is an altered ratio of enzyme to intact protein substrate and this may have artificially resulted in lower *in vitro* DH than anticipated. Secondly, and likely the major cause for the lower *in vitro* DH results, involves the method used in these studies

that used enzymes isolated from the pyloric caeca of Atlantic cod which function at a pH of 7 or higher (Danulat and Kausch, 1984). Unlike other animal and plant protein sources, the major by-product of zooplankton and crustacean processing is the carapace or shell which may contain 50–80% chitin (poly- $\beta$ -(1 $\rightarrow$ 4)-N-acetyl-glucosamine) and relatively high levels of ash (>15%) which have both shown high *in vivo* digestibility in gadoids (Danulat, 1987; Danulat and Kausch, 1984; Toppe *et al.*, 2006). The problem is that under the *in vivo* conditions such as those used in **Chapters 2 and 3**, these ingredients are exposed to an environment of acidic pH (3.8-6.5) and endogenous chitinase enzymes in the stomach ‘prior to’ entry into the alkaline (>pH 7) pyloric caeca (Danulat and Kausch 1984; Grabner 1985; Jeuniaux 1966). This *in vivo* ‘preparatory’ gastric phase is unavailable in an *in vitro* pH-Stat assay using digestive enzymes from the pyloric caeca only, like that of **Chapter 6**. In fact, Danulat and Kausch (1984) demonstrated that the activity of chitinase enzyme in the gadoid pyloric caeca is lower than that of the stomach and what little chitinolytic activity does exist in the pyloric caeca is not optimized at pH levels above 6.5. This is in agreement with other monogastric animals like poultry that showed that the acid (gastric) phase was critical for chitin and chitosan digestion because it provides a preparatory phase whereby acidic gastric juices dissolve and swell the molecules, thus permitting a higher substrate availability for chitinase enzyme activity (Hirano *et al.*, 1990) and subsequent alkaline protease activity. Since the enzyme fractions used in **Chapter 6** were extracted only from the pyloric caeca at pH 7, these particular test ingredients lacked the benefit of a preparatory low gastric pH and chitinase pre-exposure phase that they would have had during *in vivo* digestion and not as important for the other low-chitin, low-ash feed ingredients. Thus, it is not surprising that the ash and chitin-rich crustacean meals could be less digested under these specific *in vitro* conditions and especially for the particular sample of shrimp meal used in these studies which contained an unusually high level of ash (38%). In fact, consistent lower than expected *in vivo* protein ADC and *in vitro* protein DH was observed for this ingredient in **Chapters 2, 3 and 6**. Bassompierre *et al.* (1998a) found improved agreement between *in vivo* protein utilization (measured in rats) and *in vitro* protein DH (measured in rainbow trout) when an *in vitro* acidic (pH 3.8) gastric phase was implemented prior to the *in vitro* alkaline (pH 7.8) intestinal digestion phase. Similar

increases in *in vitro* DH following an acid pre-step have been demonstrated using rainbow trout pyloric caeca enzymes (Grabner and Hofer, 1985) and purified mammalian enzymes (Rothenbuhler and Kinsella, 1985). However, many authors concluded that the improvement was only marginal and resulted in a more complex and time-consuming assay, which may not be practical for use by the feed industry. Alarcón *et al.* (2002) also found higher DH values with seabream after an acid pre-digestion, although the improvement was only observed for some ingredients (corn gluten meal, meat and bone meal, fish meal, soybean meal and blood meal) but not others (squid meal, lupin meal and green pea meal). Similarly, Rothenbuhler and Kinsella (1985) observed that an acid pre-treatment greatly enhanced the *in vitro* DH of soy protein and casein but reduced it for bovine serum albumin. Recent work with other fish species on the development of a gastrointestinal model (GIM) that incorporates both the gastric acidic and intestinal alkaline phase, the use of bile salts and also a pH ‘transition’ phase (Hamdan *et al.*, 2009; Morales and Moyano, 2010) may also be useful for gadoid species.

The low nutritional value of hydrolyzed feather meal for gadoid feeds was confirmed by both *in vivo* protein ADC (**Chapter 3**) and *in vitro* protein DH methods (**Chapter 6**) and was not unexpected. Similar findings have been reported for other farmed fish species and also other farmed terrestrial animals. The low nutritional value may be due to high levels of poorly digestible keratin protein (Dong *et al.* 1993; Hardy and Barrows 2002; Yu *et al.* 2004), an inferior essential amino acid profile with low levels of methionine, lysine, histidine and tryptophan, the presence of disulfide bonding (Moran *et al.* 1966) and the presence of indigestible amino acid processing products, namely lysinoalanine and lanthionine (Williams *et al.*, 1991; Wang and Parsons 1997). This limits the use of high proportions of feather meal in gadoid feeds. It appears that global poultry production will continue to rise and availability of poultry feathers from the processing industry is enormous (4,500 million tonnes annually) and they routinely contain high (>80%) levels of total protein (Hertrampf and Piedad-Pascual 2000; Bertsch and Coello 2005). Cost-effective processes that can further increase the protein quality of feather meals would greatly increase their feeding value and provide an excellent high protein alternative ingredient for marine fish and other animal feeds (Bertsch and Coello 2005).

For plant-origin feed ingredients, the *in vitro* DH values obtained in **Chapter 6** were highest (17-21%) for wheat gluten meal, soy protein isolate, soy protein concentrate and canola protein concentrate; high (10-13%) for soybean meal, white lupin meal and canola meal and mid-range (6-9%) for pea protein concentrate and flaxseed meal. The results for wheat gluten meal, all soy-based products and white lupin meal are in agreement with conventional *in vivo* protein ADC results (**Chapters 2 and 3**) that also showed high to very high protein digestibility for these ingredients (90-100%). In contrast, it appears that *in vitro* DH may overestimate the relative protein quality for canola protein concentrate, canola meal and flaxseed meal, as their *in vivo* protein ADC (**Chapter 3**) were found to be high (89%), mid-range (76-83%) and low (53%), respectively while their *in vitro* DH (**Chapter 6**) were found to be very high (17%), high (12%) and mid-range (9%), respectively. The relatively high DH found for these ingredients is consistent with results for canola protein concentrate found during earlier *in vitro* digestion studies with rainbow trout and rats, where relatively higher DH was also observed (Dimes and Haard 1994; Gauthier *et al.* 1982; Henry and Ford 1965). Under *in vivo* conditions, inclusion of dietary ingredients containing high fibre typically results in lowered protein quality (reduced protein ADC) in fish feeds and this is attributed to decreased proteolytic enzyme activity (Falge *et al.* 1978) and shortened gut-transit time (Jobling 1981; Steffens 1989). This was observed in particular for canola meal and flaxseed meal used in **Chapters 2 and 3** where protein ADC was low (50-83%) and fecal output was very high from fish fed these high-fibre test ingredients. By contrast, the high indigestible fibre content of these ingredients tends to elevate digestibility estimations (increased protein DH) under *in vitro* situations. It has been shown that the fibre component of some plant-based feed ingredients have especially high buffering capacity in the presence of proteolytic enzymes and this high fibre content and subsequent high buffering capacity requires excessive use of NaOH titrant causing over-estimates of protein digestibility via *in vitro* methods (O'Hare *et al.* 1984). The *in vitro* pH-Stat assays used in **Chapter 6** used a procedural blank to account for this high buffering capacity and other sources of non-enzymatic hydrolysis, whereas previous studies with salmonids and other marine fish and shellfish have either used distilled water or no blank at all. Although processing conditions play a large role in protein quality of feed

ingredients of both plant and animal-origin, it has been suggested that when higher *in vitro* protein DH values are observed for plant-origin ingredients, the primary causes may also be due to higher protein solubility, higher percentage of amino acids that are susceptible to alkaline protease cleavage and differences in peptide bond flexibility (Alarcón *et al.* 2002).

It has been shown in other fish and shellfish species that potential inconsistencies between *in vitro* protein DH and *in vivo* protein ADC based on quantification of fecal nitrogen may involve the effects of ingredient composition, dietary inclusion level and poor palatability (Lemos *et al.* 2009). It is likely that the use of 30% plant protein substitution in the initial *in vivo* protein ADC trials may have been too high given the low palatability of some plant protein ingredients. It has been demonstrated for gadoids that inclusion levels of 10-50% fish meal and 10-40% soybean meal had no significant effect on *in vivo* protein ADC (Kim *et al.*, 2006, 2007), however, it remains unclear what the effect would be with other less digestible, less palatable ingredients. It is highly likely that some of the ingredients used in these studies may not be used at the 30% replacement level under practical, commercial aquafeed conditions due to undesirable proximate composition, inferior amino acid profile, palatability problems, feed processing (pelleting/extrusion) problems, anti-nutritional factors and cost. The robustness of the correlations between *in vivo* protein ADC and *in vitro* protein DH could be strengthened with further determination of *in vivo* protein ADC data conducted at more practical ingredient inclusion levels (Lemos *et al.* 2009; Tacon and Akiyama 1997).

The results presented in **Chapter 6** demonstrated that the *in vitro* DH assay used may be a suitable tool for assessing the effect of processing on particular plant protein ingredients for gadoids, which is in agreement with studies with terrestrial animals (Rothenbuhler and Kinsella 1985) and shrimp (García-Carreño *et al.* 1997; Lemos and Tacon 2011). The *in vitro* DH results (**Chapter 6**) for the variously processed canola and soy products (e.g. meal, concentrate and isolate) mirrored ( $r = 0.90$  and  $0.99$ , respectively) the *in vivo* protein ADC results of **Chapter 3**. It is well documented that the various processing stages from intact beans or seeds to de-hulled meals and ultimately the production of protein concentrates and isolates can significantly reduce the levels of poorly digestible non-protein components such as fibre, oligosaccharides, non-starch

polysaccharides and phytic acid (Storebakken *et al.* 1998, 2000) and also inactivate protease inhibitors (Anderson and Wolf 1995), which can negatively affect protein quality and nutrient digestion in fish. As such, through an appropriate combination of physical, chemical and thermal processing, these antinutritional components are reduced, inactivated and/or the protein structures altered through thermal processing permitting higher protease activity on peptide bonds (García-Carreño *et al.* 1997; Hsu *et al.* 1977) and improved accessibility of protein to enzymatic hydrolysis. The mode of action of plant-based anti-nutritional factors in monogastric animals has been well studied and is through nutrient binding with bile salts and other anti-nutritional components (e.g., phytic acid, metal ions), obstruction of protease activity (proteolytic enzyme inhibition), accelerated movement of digesta through the intestinal tract and increased viscosity of digesta (Storebakken *et al.*, 1998, 2000; Francis *et al.*, 2001; Dendougui and Schwedt, 2004; Leenhouders *et al.*, 2006; Krogdahl *et al.*, 2010). As discussed, the relationship between the level of processing of canola products (meal to concentrate) and soy products (meal to concentrate to isolate) used in **Chapter 6** was similar. This was also reflected *in vivo* in **Chapter 3** where protein ADC for canola and soybean was improved with processing (e.g. isolate  $\geq$  concentrate > meal).

The ultimate goal of determining the *in vitro* protein DH of feed ingredients is to utilize this data in conjunction with *in vivo* protein ADC values by generating a predictive equation(s). However, the generation of an ‘all-inclusive’ predictive regression equation may not be possible. It is more likely that several predictive equations for each species are required according to the origin of feed ingredient, level of processing and relative digestibility as discussed by several authors (Pedersen and Eggum 1983; Jaguelin *et al.* 1994; Shipton and Britz 2002; Lemos *et al.* 2009). Specifically, Haard (1993) pointed out that *in vitro* pH-Stat assays may overestimate protein quality of plant-origin sources relative to those of animal-origin for salmonids. This has also been documented for shrimp (Fernández Gimenez *et al.* 2009), seabream (Alarcón *et al.* 2002) and mammals (Marletta *et al.* 1992). This was consistent with the findings of **Chapter 6** where the DH of plant-origin ingredients were higher than those of animal-origin ingredients and this highlights the necessity for separate equations for plant-origin and animal-origin feedstuffs.



Measurement of the *in vitro* DH by pH-Stat using enzymes from the pyloric caeca of farmed Atlantic cod (**Chapter 6**) provided results that were in general agreement with *in vivo* protein digestibility of many conventional and novel feed ingredients including of fish and poultry meals, soy-based products, wheat gluten and lupin meals, while ingredients containing high levels of chitin, ash and/or fibre were not as successful relative to the results measured *in vivo* (**Chapters 2 and 3**). As discussed, in order to make *in vitro* DH data useful for research or industrial use, it is necessary to combine these data with known protein quality data measured *in vivo* through the generation of predictive regression equations. For finfish, only one of these equations currently exists for rainbow trout (Dimes and Haard 1994) while there are several equations for white shrimp (Ezquerria *et al.* 1997, 1998; Lemos *et al.* 2009). With the exception Lemos *et al.* (2009), these few published predictive equations are based on a small number of test feed ingredients (<10) providing data from a relatively static set of environmental conditions and have generated only a few small data sets and predominantly linear models. This is highly unlikely if the studies were conducted under natural environmental conditions of fish farming (e.g. culture conditions and nutritional history of donor animals) and a higher number and composition/quality range of test ingredients had been assayed (Bender 1982; Jørgensen 1995). Indeed, this was the case reported by Lemos *et al.* (2009) who conducted extensive DH assays with shrimp hepatopancreas enzymes from various different culture conditions, enzyme batches and activities and using a large number (26) of test ingredients with a wide range of composition (28-99% protein, 0-20% fat, 0-47% carbohydrate, 0-49% ash) and *in vivo* protein digestibility (59-100%). These authors found that non-linear models were required to describe the relationships between *in vivo* protein ADC and *in vitro* protein DH as was the case for gadoids in **Chapter 6** of this thesis.

To accurately 'model' this relationship and generate truly robust predictive equations for a particular species, data sets from numerous feed ingredients from a large number of processing conditions must be included in order to be adopted by the feed industry and researchers. At this stage, it would be wise for the aquaculture feed industry to learn from past mistakes associated with the human food and farm animal feed sectors. For example, many correlations between rapid-screening *in vitro* assays and *in vivo*

performance have been made over the past century, only to be discredited once a wider range of samples were tested (Bender 1982). Although the gadoid *in vitro* data generated in **Chapters 5 and 6** and the comparisons with *in vivo* data from **Chapters 2 and 3** should provide the basis for further work, the current body of knowledge on gadoid nutrition needs additional research to develop more robust equations. As concluded for the salmonid work in the early 1990s (Dimes *et al.* 1994a) upon which these studies were based, seabream by Alarcón *et al.* (2002) and shrimp in the mid- to late 1990s (Ezquerria *et al.* 1997; Lan and Pan 1993), additional data are needed to establish a clear relationship between *in vitro* and *in vivo* assays for fish, including gadoids.

# References

- Adler-Nissen, J., Eriksen, S., Olsen, H.S. (1983)** Improvement of the functionality of vegetable proteins by controlled enzymatic hydrolysis. *Qual. Plant Foods Hum. Nutr.* 32, 411-423.
- Adler-Nissen, J. (1986)** Enzymatic hydrolysis of food proteins. Elsevier, New York, NY. 427 pp.
- Aiken, D.E. (2003)** Early rearing of haddock: State of the Art. Aquaculture Association of Canada, Special Publication Number 7. 136 pp.
- Aksnes, A. (1995)** Growth, feed efficiency and slaughter quality of salmon, *Salmo salar* L., given feeds with different ratios of carbohydrate and protein. *Aquaculture Nutrition* 1, 241–248.
- Aksnes, A., Hjertnes, T., Opstvedt, J. (1996)** Effect of dietary protein level on growth and carcass composition in Atlantic halibut (*Hippoglossus hippoglossus* L.). *Aquaculture* 145, 225–233.
- Alarcón, F.J., Moyano, F.J., Díaz, M. (1995)** Digestión proteica en peces marinos: una vision general. *Actas V Congreso Nac. Acuicultura*, 455-260.
- Alarcón, F.J., Díaz, M., Moyano, F.J., Abellán, E. (1998)** Characterization and functional properties of digestive proteases in two *sparids*; gilthead seabream (*Sparus aurata*) and common dentex (*Dentex dentex*). *Fish Physiol. Biochem.* 19, 257-267.
- Alarcón, F.J., Moyano, F.J., Díaz, M., Fernández- Díaz, C., Yúfera, M. (1999)** Optimization of the protein fraction of microcapsules used in feeding of marine fish larvae using *in vitro* digestibility techniques. *Aquaculture Nutrition* 5, 107-113.
- Alarcón, F.J., Moyano, F.J., Díaz, M. (2002)** Evaluation of different protein sources for aquafeeds by an optimised pH-stat system. *J. Sci. Food. Agric.* 82, 697-704.
- Alarcón, F.J., de Oña, C., Díaz, M., García-Carreño, F.L., Moyano, F.J., Navarrete del Toro, M.A. (2007)** The effect of proteinase inhibitors in food protein hydrolysis by digestive proteinases of white shrimp (*Penaeus vannamei*) larvae. *J. Sci. Food Agric.* 87, 120-126.
- Alexis, M.N. (1997)** Fish meal and fish oil replacers in Mediterranean marine fish diets. In: *Feeding Tomorrow's Fish. Proceedings of the Workshop of the CIHEAM Network on Technology of Aquaculture in the Mediterranean* (ed. By A. Tacon and B. Barsureo), pp.183-204. CIHEAM, Zaragoza, Spain.
- Allan, G.L., Rowland, S.J., Parkinson, S., Stone, D.A.J., Jantrarotai, W. (1999)** Nutrient digestibility for juvenile silver perch *Bidyanus bidyanus*: development of methods. *Aquaculture* 170, 131–145.
- Allan, G.L., Parkinson, S., Booth, M.A., Stone, D.A.J., Rowland, S.J., Frances, J., Warner-Smith R. (2000)** Replacement of fish meal in diets for Australian silver perch, *Bidyanus bidyanus*: I. Digestibility of alternative ingredients. *Aquaculture* 186, 293-310.
- Anderson, J.S., Lall, S.P., Anderson, D.M., Chandrasoma, J. (1992)** Apparent and true availability of amino acids from common feed ingredients for Atlantic salmon (*Salmo salar*) reared in seawater. *Aquaculture* 108, 111-124.
- Anderson, J.S., Lall, S.P., Anderson, D.M., McNiven, M.A. (1993)** Evaluation of protein quality in fish meals by chemical and biological assays. *Aquaculture* 115, 305-325.

- Anderson, J.S., Lall, S.P., Anderson, D.M., McNiven, M.A. (1995)** Availability of amino acids from various fish meals fed to Atlantic salmon (*Salmo salar*). *Aquaculture* 138, 291–301.
- Anderson, J.S., Higgs, D.A., Beames, R.M., Rowshandeli, M. (1997)** Fish meal quality assessment for Atlantic salmon (*Salmo salar* L.) reared in sea water. *Aquaculture Nutrition* 3, 25-38.
- Anderson, R.L., Wolf, W.R. (1995)** Compositional changes in trypsin inhibitors, phytic acid, saponins and isoflavones related to soybean processing. *J. Nutr.* 125, 581-588.
- Árnason, J., Björnsdóttir, R., Arnarsson, I., Árnadóttir, G.S., Thorarensen, H. (2010)** Protein requirements of Atlantic cod, *Gadus morhua* L. *Aquaculture Research* 41, 385-393.
- Arzel, J., Guillaume, J., Kaushik, S.J. (1999)** Composition and nutritive value of raw materials. In: *Nutrition and Feeding of Fish and Crustaceans* (ed. by J. Guillaume, S. Kaushik, P. Bergot, R. Métailler), Praxis Publishing, Chichester, UK, 408 pp.
- Ásgeirsson, B., Fox, J.W., Bjarnason, J.B. (1989)** Purification and characterization of trypsin from the poikilotherm *Gadus morhua*. *European J. Biochem.* 180, 85-94.
- Ásgeirsson, B., Bjarnason, J.B. (1991)** Structural and kinetic properties of chymotrypsin from Atlantic cod (*Gadus morhua*). Comparison with bovine chymotrypsin. *Comp. Biochem. Physiol.* 99B, 327-335.
- Austreng, E. (1978)** Digestibility determination in fish using chromic oxide marking and analysis of contents from different segments of the gastrointestinal tract. *Aquaculture* 13, 265–272.
- Austreng, E., Skrede, A., Eldegard, Å. (1980)** Digestibility of fat and fatty acids in rainbow trout and mink. *Aquaculture* 19, 93-95.
- Baker, R.T.M., Pfeiffer, A.M., Schöner, F.-J., Smith-Lemmon, L. (2002)** Pigmenting efficacy of astaxanthin and canthaxanthin in fresh-water reared Atlantic salmon, *Salmo salar*. *Animal Feed Science and Technology* 99, 97–106.
- Bassompierre, M. (1997)** *In vitro* protein digestion in fish. Ph.D. Thesis. Aalborg University, Aalborg, Denmark, 126 pp.
- Bassompierre, M., Nielsen, H.H., Børresen, T. (1993)** Purification and characterization of elastase from the pyloric caeca of rainbow trout (*Oncorhynchus mykiss*). *Comp. Biochem. Physiol.* 106B, 331-336.
- Bassompierre, M., Kristiansen, H.R., McLean, E. (1998)** Influence of weight on *in vitro* protein digestive capacity of rainbow trout. *J. Fish Biology* 52, 213-216.
- Bassompierre, M., Ostefeld, T.H., McLean, E., Torrissen, K. (1998)** Growth and *in vitro* protein digestion of Atlantic salmon with genetically different trypsin isozymes. *Aquaculture International* 6, 47-56.
- Bassompierre, M., Kjær, A., McLean, E. (1998)** Simulating protein digestion in trout. A rapid and inexpensive method for documenting fish meal quality and screening novel protein sources for use in aquafeeds. *Ribarstvo* 55, 137-145.
- Bender, A.E. (1982)** Evaluation of protein quality: Methodological consideration. *Proc. Nutr. Soc.* 41, 267-276.

- Berge, G.M., Storebakken, T. (1991)** Effect of dietary fat level on weight gain, digestibility and fillet composition of Atlantic halibut. *Aquaculture* 99, 331–338.
- Berge, G.M., Grisdale-Helland, B., Helland, S.J. (1999)** Soy protein concentrate in diets for Atlantic halibut (*Hippoglossus hippoglossus*). *Aquaculture* 178, 139-148.
- Bertsch, A., Coello, N. (2005)** A biotechnological process for treatment and recycling poultry feathers as a feed ingredient. *Biores. Technol.* 96, 1703-1708.
- Bjarnason, J. (2001)** Biotechnological applications of fish offal in Iceland. Conference Verdiskaping av marine biprodukter etter år 200. Trondheim, Jan. 2001.
- Björnsson, B., Steinarsson, A., Árnason, T. (2007)** Growth model for Atlantic cod (*Gadus morhua*): Effects of temperature and body weight on growth rate. *Aquaculture* 271, 216-226.
- Bligh, E.G., Dyer, W.J. (1959)** A rapid method of total lipid extraction and purification. *Can. J. Biochem. Biophys.* 37, 911–917.
- Bøhle, B. (1974)** Temperaturpreferanse hos torsk (*Gadus morhua* L.). *Fisken og Havet Ser. B* 20, 1-28.
- Boyce, D.G., Lewis, M.R., Worm, B. (2010)** Global phytoplankton decline over the past century. *Nature* 466, 591-596.
- Bradford, M.M. (1976)** A rapid and sensitive method for the quantitation of microgram quantities of protein utilizing the principle of protein-dye binding. *Anal. Biochem.* 72, 248-254.
- Bricknell, I.R., Bron, J.E., Bowden, T.J. (2006)** Diseases of gadoid fish in cultivation: a review. *ICES Journal of Marine Science* 63, 253-266.
- Brown, J.A., Minkoff, G., Puvanendran, V. (2003)** Larviculture of Atlantic cod (*Gadus morhua*): progress, protocols and problems. *Aquaculture* 227, 357-372.
- Brown, L., Renner, M., Flavin, C. (1998)** Vital Signs 1998: The Environmental Trends that are Shaping Our Future. Worldwatch Institute, Washington, DC. In: Costa-Pierce, B.A. (2002) The ‘blue revolution’ – aquaculture must go green. *World Aquaculture* 33, 4-5, 66.
- Buchanan, R.A. (1969)** *In vivo* and *in vitro* methods of measuring nutritive value of leaf protein preparation. *Brit. J. Nutr.* 23, 533-545.
- Buddington, R.K., Diamond, J.M. (1986)** Aristotle revisited: The function of pyloric caeca in fish. *Proc. Natl. Acad. Sci.* 83, 8012-8014.
- Buddington, R.K., Diamond, J.M. (1987)** Pyloric caeca of fish: ‘new’ absorptive organ. *Am. J. Physiol.* 252, 65-76.
- Bureau, D.P. (2004)** Factors affecting metabolic waste outputs in fish. In: Cruz Suárez, L.E., Ricque, M.D., Nieto López, M.G., Villarreal, D., Scholz, U., y González, M. (eds.) *Avances en Nutrición Acuícola VII. Memorias del VII Simposium Internacional de Nutrición Acuícola*, 16-19 November 2004, Hermosillo, Sonora, México, pp. 2-7.
- Bureau, D.P., Harris, A.M., Cho, C.Y. (1999)** Apparent digestibility of rendered animal protein ingredients for rainbow trout (*Oncorhynchus mykiss*). *Aquaculture* 180, 345–358.

- Bureau, D.P., Kaushik, S.J., Cho, C.Y. (2002)** Bioenergetics. In: Halver, J.E., Hardy, R.W. (eds.) Fish Nutrition, 3rd Edition. Academic Press, New York, USA. pp. 1-59.
- Burel, C., Boujard, T., Tulli, F., Kaushik, S.J. (2000)** Digestibility of extruded peas, extruded lupin and rapeseed meal in rainbow trout (*Oncorhynchus mykiss*) and turbot (*Psetta maxima*). Aquaculture 188, 285-298.
- Buttle, L.G., Crampton, V.O., Williams, P.D. (2001)** The effect of feed pigment type on flesh pigment deposition and color in farmed Atlantic salmon, *Salmo salar*. Aquaculture Research 32, 103-111.
- Carter, C.G., Bransden, M.P., van Barneveld, R.J., Clarke, S.M. (1999)** Alternative methods for nutrition research on the southern bluefin tuna, *Thunnus maccoyii*: *in vitro* digestibility. Aquaculture 179, 57-70.
- Carter, C.G., Houlihan, D.F., Kiessling, A., Medale, F., Jobling, M. (2001)** Physiological effects of feeding. In: Houlihan, D.F., Boujard, T., Jobling, M. (eds.) Food Intake in Fish. Blackwell Science, Oxford, UK, pp. 297-331.
- Calvo-Carrillo, C., Castro-González, I., Sánchezarmas-Luna, R., Pérez-Gil-Romo, F. (1995)** Crude fiber and chitin in the red crab (*Pleuroncodes planipes*, Stimpson): similarities and differences. Ciencias Marinas 21, 179-186.
- Chambers, M.D., Howell, W.H. (2006)** Preliminary information on cod and haddock production in submerged cages off the coast of New Hampshire, USA. ICES Journal of Marine Science 63, 385-392.
- Cheng, Z.J., Hardy, R.W. (2002)** Apparent digestibility coefficients of nutrients and nutritional value of poultry by-product meals for rainbow trout, *Oncorhynchus mykiss*, measured *in vivo* using settlement. J. World Aquac. Soc. 33, 458-465.
- Cheng, Z.J., Hardy, R.W. (2003)** Effects of extrusion processing of feed ingredients on apparent digestibility coefficients of nutrients for rainbow trout (*Oncorhynchus mykiss*). Aquaculture Nutrition 9, 77-83.
- Cheng, Z.J., Hardy, R.W., Huige, N.J. (2004)** Apparent digestibility coefficients of nutrients in brewer's and rendered animal byproducts for rainbow trout (*Oncorhynchus mykiss* (Walbaum)). Aquac. Res. 35, 1-9.
- Cho, C.Y. (1987)** La Energía en la nutrición de los peces. In: Espinosa de los Monteros, J., Labarta, U. (eds.). Nutrición en Acuicultura, CAICYT, Madrid, Spain, pp. 197-237.
- Cho, C.Y., Slinger, S.J. (1979)** Apparent digestibility measurement in feedstuffs for rainbow trout. In: Finfish Nutrition and Fishfeed Technology, Vol. 2 (ed. By J.E. Halver and K. Tiews), pp. 239-247. Heinemann, Berlin, Germany.
- Cho, C.Y., Slinger, S.J., Bayley, H.S. (1982)** Bioenergetics of salmonid species: energy intake, expenditure and productivity. Comparative Biochemistry and Physiology 73B, 25-41.
- Cho, C.Y., Kaushik, S.J. (1985)** Effects of protein intake on metabolizable and net energy values of fish diets. In: Cowey, C.B., Mackie, A.M., Bell, J.G. (eds). Nutrition and Feeding in Fish, Academic Press, London, UK, pp. 95-117.

- Cho, C.Y., Kaushik, S.J. (1990)** Nutritional energetics in fish: protein and energy utilization in rainbow trout. *World Rev. Anim. Nutr. Diet.* 61, 132-172.
- Choubert, G., Cravedi, J.P., Laurentie, M. (2009)** Effect of alternate distribution of astaxanthin on rainbow trout (*Oncorhynchus mykiss*) muscle pigmentation. *Aquaculture* 286, 100-104.
- Choubert, G. (2010)** Response of rainbow trout (*Oncorhynchus mykiss*) to varying dietary astaxanthin/canthaxanthin ratio: color and carotenoid retention of the muscle. *Aquaculture Nutrition* 16, 528-535.
- Clarke, W.C., Higgs, D., Whyte, J.N.C. (2000)** Effects of varying dietary protein and lipid levels on growth and feed efficiency of juvenile sablefish, *Anoplopoma fimbria*. In: Proceedings from the Aquaculture Association of Canada Conference, Moncton, NB, Canada, 28–31 May, p. 125.
- Córdova-Murueta, J.H., García-Carreno, F.L. (2002)** Nutritive value of squid and hydrolyzed protein supplement in shrimp feed. *Aquaculture* 210, 371-384.
- Cowey, C.B. (1992)** Nutrition: estimating requirements of rainbow trout. *Aquaculture* 100, 177-189.
- Crampton, V.O., Nanton, D.A., Ruohonen, K., Skjervold, P.O., El-Mowafi, A. (2010)** Demonstration of salmon farming as a net producer of fish protein and oil. *Aquaculture Nutrition* 16, 437-446.
- Dabrowski, K., Guderley, H. (2002)** Intermediary metabolism. In: Halver, J.E., Hardy, R.W. (eds.) *Fish Nutrition*, 3rd Edition. Academic Press, New York, USA. pp. 309-365.
- Danulat, E., Kausch, H. (1984)** Chitinase activity in the digestive tract of the cod, *Gadus morhua* (L.). *J. Fish Biol.* 24, 125–133.
- Danulat, E. (1986)** Role of bacteria with regard to chitin degradation in the digestive tract of the cod, *Gadus morhua*. *Marine Biology* 90, 335-343.
- Danulat, E. (1986)** The effects of various diets on chitinase and beta-glucosidase activities and the condition of cod, *Gadus morhua*. *Journal of Fish Biology* 28, 191-197.
- Danulat, E. (1987)** Digestibility of chitin in cod, *Gadus morhua*, *in vivo*. *Helgoländer Meeresunters* 41, 425-436.
- Dendougui, F., Schwedt, G. (2004)** *In vitro* analysis of binding capacities of calcium to phytic acid in different food samples. *Eur. Food Res. Technol.* 219, 409-415.
- Dias, J., Alvarez, M.J., Diez, A., Arzel, J., Corraze, G., Bautista, J.M., Kaushik, S.J. (1998)** Regulation of hepatic lipogenesis by dietary protein/energy in juvenile European sea bass (*Dicentrarchus labrax*). *Aquaculture* 161, 169–186.
- Dias, J., Huelva, C., Denis, M.T., Métailler, R. (1998)** Influence of dietary bulk agents (silica, cellulose and a natural elite) on protein digestibility, growth, feed intake and feed transit time in European seabass (*Dicentrarchus labrax*) juveniles. *Aquat. Living Resour.* 11, 219–226.
- Dimes, L.E., Haard, N.F. (1994)** Estimation of protein digestibility – I. Development of an *in vitro* method for estimating protein digestibility in salmonids (*Salmo gairdneri*). *Comp. Biochem. Physiol.* 108A, 349-362.

- Dimes, L.E., Haard, N.F., Dong, F.M., Rasco, B.A., Forster, I.P., Fairgrieve, W.T., Arndt, R., Hardy, R.W., Barrows, F.T., Higgs, D.A. (1994)** Estimation of protein digestibility – II. *In vitro* assay of protein in salmonid feeds. *Comp. Biochem. Physiol.* 108A, 363-370.
- Dimes, L.E., Garcia-Carreno, F.L., Haard, N.F. (1994)** Estimation of protein digestibility – III. Studies on the digestive enzymes from the pyloric ceca of rainbow trout and salmon. *Comp. Biochem. Physiol.* 109A, 349-360.
- Dong, F.M., Hardy, R.W., Haard, N.F., Barrows, F.T., Rasco, B.A., Fairgrieve, W.T., Forster, I.P. (1993)** Chemical composition and protein digestibility of poultry by-product meals for salmonid diets. *Aquaculture* 116, 149–158.
- Dos Santos, J., Burkow, I.C., Jobling, M. (1993)** Patterns of growth and lipid deposition in cod (*Gadus morhua* L.) fed natural prey and fish-based feeds. *Aquaculture* 110, 173-189.
- Duguay, S.J., Mommsen, T.P. (1994)** Molecular aspects of pancreatic peptides. In: Hoar, W.S., Randall, D.J. (eds.) *Fish Physiology*. Academic Press, San Diego, CA, pp 225-271.
- Ebeling, M.E. (1968)** The Dumas method for nitrogen in feeds. *Journal of the Association of Official Analytical Chemists* 51, 766-770.
- El-Mowafi, A.F., Dorrell, H., Bureau, D.P. (2000)** Potential of a pH-stat method to estimate apparent digestibility of protein in salmonids. IX International Symposium on Nutrition and Feeding of Fish, 21–25 May 2000, Miyazaki, Japan.
- Einarsson, S., Jonsson, A.C., Davies, P.S. (1997)** Seasonal variation in trypsin activity in juvenile Atlantic salmon upper and lower modal groups. *J. Fish Biology* 51, 1209-1218.
- Einen, O., Roem, A.J. (1997)** Dietary protein/energy ratios for Atlantic salmon in relation to fish size: growth, feed utilization and slaughter quality. *Aquaculture Nutrition* 3, 115-126.
- Engin, K., Carter, C.G. (2002)** Ingredient apparent digestibility coefficients for the Australian short-finned eel (*Anguilla australis australis*, Richardson). *Anim. Sci.* 75, 401–413.
- Ezquerro, J.M., Garcia-Carreño, F.L., Civera, R., Haard, N.F. (1997)** pH-stat method to predict digestibility *in vitro* in white shrimp *Penaeus vannamei*. *Aquaculture* 157, 249–260.
- Ezquerro, J.M., Garcia-Carreño, F.L., Carrillo, O. (1998)** *In vitro* digestibility of protein sources for white shrimp *Penaeus vannamei*. *Aquaculture* 163, 123–136.
- Fagbenro, O.A., Bello-Olusoji, O.A. (1997)** Preparation, nutrient composition and digestibility of fermented shrimp head silage. *Food Chemistry* 60, 489-493.
- Fagen, B.M. (2006)** *Fish on Friday: Feasting, Fasting and the Discovery of the New World*. Basic Books Publishing/Perseus Books Group, New York, NY. 338 p.
- Falge, R., Schpanof, L., Jurss, K. (1978)** Amylase, esterase and protease activity in the intestine content of rainbow trout *Salmo gairdneri* Rich. after feeding with feed containing different amounts of starch and protein. *Journal of Ichthyology* 18, 283-278.



- Farrell, A.P., Friesen, E.N., Higgs, D.A., Ikonou, M.K. (2010)** Toward improved public confidence in farmed fish quality: A Canadian perspective on the consequences of diet selection. *Journal of the World Aquaculture Society* 41, 207-223.
- Farzaneh-Far, R., Lin, J., Epel, E.S., Harris, W.S., Blackburn, E.H., Whooley, M.A. (2010)** Association of marine omega-3 fatty acid levels with telomeric aging in patients with coronary heart disease. *J. American Med. Assoc.* 303, 250-257.
- Fernández-García, E., Lérída-Carvajal, I., Pérez-Gálvez, A. (2009)** *In vitro* bioaccessibility assessment as a prediction tool of nutritional efficiency. *Nutrition Research* 29, 751-760.
- Fernández Gimenez, A.V., Díaz, A.C., Velurtas, S.M., Fenucci, J.L. (2009)** *In vivo* and *in vitro* protein digestibility of formulated feeds for *Artemesia longinaris* (Crustacea, Penaeidae). *Braz. Arch. Biol. Technol.* 52, 1379-1386.
- Fisheries and Oceans Canada (2010)** Aquaculture in Canada, socio-economic impact of aquaculture in Canada. Document DFO/2010-1645, 54 p.
- Food and Agriculture Organization (2002)** The state of world fisheries and aquaculture 2002. FAO Fisheries Department, Rome, Italy, 150 p.
- Food and Agriculture Organization (2009)** The state of world fisheries and aquaculture 2008. FAO Fisheries and Aquaculture Department, Rome, Italy, 176 p.
- Food and Agriculture Organization (2009)** Commercial aquaculture and economic growth, poverty alleviation and food security: Assessment framework. FAO Fisheries and Aquaculture Technical Paper No. 512. Rome, Italy.
- Ford, J.E., Salter, D. (1966)** Analysis of enzymatically digested food proteins by Sephadex-gel filtration. *Br. J. Nutr.* 20, 843-848.
- Førde-Skjærvik, O., Refstie, S., Aslaksen, M.A., Skrede, A. (2006)** Digestibility of diets containing different soybean meals in Atlantic cod (*Gadus morhua*); comparison of collection methods and mapping of digestibility in different sections of the gastrointestinal tract. *Aquaculture* 261, 241-258.
- Forster, I. (1999)** A note on the method of calculating digestibility coefficients of nutrients provided by single ingredients to feeds of aquatic animals. *Aquaculture Nutrition* 5, 143-145.
- Francis, G., Makkar, H.P.S., Becker, K. (2001)** Antinutritional factors present in plant-derived alternate fish feed ingredients and their effects in fish. *Aquaculture* 199, 197-227.
- Frantsi, C., Lanteigne, C., Blanchard, B., Alderson, R., Lall, S., Johnson, S., Leadbeater, S., Martin-Robichaud, D., Rose, P. (2002)** Haddock culture in Atlantic Canada. *Bulletin of the Aquaculture Association of Canada* 102, 31-34.
- Fuller, M.F. (1991)** *In vitro* Digestion for Pigs and Poultry. CAB International, Wallington, Oxon, UK. 209 pp.
- Fujihara, S., Sasaki, H., Aoyagi, Y., Sugahara, T. (2008)** Nitrogen-to-protein conversion factors for some cereal products in Japan. *J. Food Sci.* 73, 204-209.

- Gamboa-Delgado, J., Le Vay, L., Fernández-Díaz, C., Cañavate, P., Ponce, M., Zerolo, R., Manchado, M. (2011)** Effect of different diets on proteolytic enzyme activity, trypsinogen gene expression and dietary carbon assimilation in Senegalese sole (*Solea senegalensis*) larvae. *Comp. Biochem Physiol.* 158B, 251-258.
- García-Carreño, F.L., Dimes, L.E., Haard, N.F. (1993)** Substrate gel electrophoresis for composition and molecular weight of proteinases or proteinaceous proteinases inhibitors. *Anal. Biochem.* 214, 65-69.
- García-Carreño, F.L., del Toro, A.V., Ezquerro, M. (1997)** Digestive shrimp proteases for evaluation of protein digestibility *in vitro*. I: Effect of protease inhibitors in protein ingredients. *J. Mar. Biotechnol.* 5, 36-40.
- Garlick, P.J., McNurlan, M.A., Bark, T., Lang, C.H., Gelato, M.C. (1998)** Hormonal regulation of protein metabolism in relation to nutrition and disease. *Journal of Nutrition* 128, 356-359.
- Gatlin III, D., Barrows, F., Bellis, D., Brown, P., Campen, J., Dabrowski, K., Gaylord, T.G., Hardy, R.W., Herman, E.M., Hu, G., Krogdahl, Å., Nelson, R., Overturf, K.E., Rust, M., Sealey, W., Skonberg, D., Souza, E.J., Stone, D., Wilson, R.F. (2007)** Expanding the utilization of sustainable plant products in aquafeeds: a review. *Aquaculture Research* 38, 551–579.
- Gauthier, S.F., Vachon, C., Jones, J.D., Savoie, L. (1982)** Assessment of protein digestibility by *in vitro* enzymatic hydrolysis with simultaneous dialysis. *J. Nutr.* 112, 1718-1725.
- Gawlicka, A., Parent, B., Horn, M.H., Ross, N., Opstad, I., Torrissen, O.J. (2000)** Activity of digestive enzymes in yolk-sac larvae of Atlantic halibut (*Hippoglossus hippoglossus*): indication of readiness for first feeding. *Aquaculture* 184, 303-314.
- Gerking, S.D. (1994)** Feeding Ecology of Fish. Academic Press. New York, NY, 416 p.
- Gildberg, A. (2004)** Digestive enzyme activities in starved pre-slaughter farmed and wild-captured Atlantic cod (*Gadus morhua*). *Aquaculture* 238, 343-353.
- Glencross, B.D., Boujard, T., Kaushik, S.J. (2003)** Influence of oligosaccharides on the digestibility of lupin meals when fed to rainbow trout, *Oncorhynchus mykiss*. *Aquaculture* 219, 703–713.
- Glencross, B., Evans, D., Dods, K., McCafferty, P., Hawkins, W., Maas, R., Sipsas, S. (2005)** Evaluation of the digestible value of lupin and soybean protein concentrates and isolates when fed to rainbow trout, *Oncorhynchus mykiss*, using either stripping or settlement faecal collection methods. *Aquaculture* 245, 211–220.
- Glencross, B.D., Booth, M., Allan, G.L. (2007)** A feed is only as good as its ingredients – a review of ingredient evaluation strategies for aquaculture feeds. *Aquaculture Nutrition* 13, 17–34.
- Glencross, B., Sweetingham, M., Hawkins, W. (2010)** A digestibility assessment of pearl lupin (*Lupinus mutabilis*) meals and protein concentrates when fed to rainbow trout (*Oncorhynchus mykiss*). *Aquaculture* 303, 59-64.
- Goddard, S.V., Fletcher, G.L. (1994)** Antifreeze proteins: their role in cod survival and distribution from egg to adult. *ICES Mar. Sci. Symp.* 198, 676–683.

- Gomes da Silva, J., Oliva-Teles, A. (1998)** Apparent digestibility coefficients of feedstuffs in seabass (*Dicentrarchus labrax*) juveniles. *Aquatic Living Resources* 11, 187-191.
- Grabner, M. (1985)** An *in vitro* method for measuring protein digestibility of fish feed components. *Aquaculture* 48, 97-110.
- Grabner, M., Hofer, R. (1985)** The digestibility of the proteins of broad bean (*Vicia faba*) and soya bean (*Glycine max*) under *in vitro* conditions simulating the alimentary tracts of rainbow trout (*Salmo gairdneri*) and carp (*Cyprinus carpio*). *Aquaculture* 48, 111-122.
- Grisdale-Helland, B., Helland, S.J. (1997)** Replacement of protein by fat and carbohydrate in diets for Atlantic salmon (*Salmo salar*) at the end of the freshwater stage. *Aquaculture* 152, 167-180.
- Grisdale-Helland, B., Helland, S.J. (1998)** Macronutrient utilization by Atlantic halibut (*Hippoglossus hippoglossus*): diet digestibility and growth of 1 kg fish. *Aquaculture* 166, 57-65.
- Grydeland, O. (2008)** Canada: Problems for one can benefit someone else. *Fish Farming Expert* 2, 30-33.
- Gudmundsdóttir, Á., Pálsdóttir, H.M. (2005)** Atlantic cod trypsins: From basic research to practical applications. *Marine Biotechnology* 7, 77-88.
- Haard, N.F. (1992)** A review of proteolytic enzymes from marine organisms and their application in the food industry. *J. Aquat. Food Prod. Technol.* 1, 17-35.
- Haard, N. (1993)** Digestibility and *in vitro* evaluation of plant protein for salmonid feed, in: Sessa, D.J., Lim, C. (Eds.), *Nutrition and Utilization Technology in Aquaculture*. American Oil Chemists Society: Champaign, pp. 1-29.
- Hagen, Ø., Solberg, C. (2010)** Fasting of farmed Atlantic cod (*Gadus morhua* L.) used as a tool to improve fillet texture during the summer. *International Journal of Food Science and Technology*. 45, 2669-2673.
- Hajen, W.E., Beames, R.M., Higgs, D.A., Dosanjh, B.S. (1993)** Digestibility of various feedstuffs by post-juvenile Chinook salmon (*Oncorhynchus tshawytscha*) in seawater. 1. Validation of technique. *Aquaculture* 112, 321-332.
- Hajen, W.E., Higgs, D.A., Beames, R.M., Dosanjh, B.S. (1993)** Digestibility of various feedstuffs by post-juvenile Chinook salmon (*Oncorhynchus tshawytscha*) in seawater. 2. Measurement of digestibility. *Aquaculture* 112, 333-348.
- Halver, J.E., Hardy, R.W. (2002)** *Fish Nutrition*, 3rd Edition. Academic Press, New York, USA. pp. 780-783.
- Hamdan, M., Moyano, F.J., Schuhardt, D. (2009)** Optimization of a gastrointestinal model applicable to the evaluation of bioaccessibility in fish feeds. *J. Sci. Food Agric.* 89, 1195-1201.
- Hansen, A.C., Karlsen, Ø., Rosenlund, G., Rimbach, M., Hemre, G.I. (2007)** Dietary plant protein utilization in Atlantic cod, *Gadus morhua* L. *Aquaculture Nutrition* 13, 200-215.
- Hansen, J.M., Lazo, J.P., Kling, L.J. (2009)** A method to determine protein digestibility of microdiets for larval and early juvenile fish. *Aquaculture Nutrition* 15, 615-626.

- Hardy, R.W. (1996)** Alternate protein sources for salmon and trout diets. *Anim. Feed Sci. Technol.* 59, 71–80.
- Hardy, R.W. (2010)** Utilization of plant proteins in fish diets: effects of global demand and supplies of fishmeal. *Aquaculture Research* 41, 770-776.
- Hardy, R.W., Masumoto, T. (1991)** Specifications for marine by-products for aquaculture, in: Akiyama, D.A., Tan, R.K.H. (Eds.), *Proceedings of the Aquaculture Feed Processing and Nutrition Workshop*, American Soybean Association, Singapore, pp. 99-108.
- Hardy, R.W., Barrows, F.T. (2002)** Diet formulation and manufacture. In: Halver, J.E., Hardy, R.W. (eds.) *Fish Nutrition*, 3rd Edition. Academic Press, New York, USA. pp. 505-600.
- Harrington, J.M., Myers, R.A., Rosenberg, A.A. (2005)** Wasted fishery resources: discarded bycatch in the USA. *Fish and Fisheries* 6, 350–361.
- Hazel, J.R., Prosser, C.L. (1974)** Molecular mechanism of temperature compensation in poikilotherms. *Physiological Reviews* 54, 620-677.
- Hemre, G.I., Lie, Ø., Lied, E., Lambertsen, G. (1989)** Starch as an energy source in feed for cod (*Gadus morhua*): digestibility and retention. *Aquaculture* 80, 261–270.
- Hemre, G.I., Sandnes, K., Lie, Ø., Torrissen, O., Waagbø, R. (1995)** Carbohydrate nutrition in Atlantic salmon, *Salmo salar* L.: growth and feed utilization. *Aquacult. Res.* 26, 149–154.
- Hemre, G.I., Karlsen, Ø., Mangor-Jensen, A., Rosenlund, G. (2003)** Digestibility of dry matter, protein, starch and lipid by cod, *Gadus morhua*: comparison of sampling methods. *Aquaculture* 225, 225-232.
- Henry, K.M., Ford, J.E. (1965)** The nutritive value of leaf protein concentrates determined in biological tests with rats and by microbiological methods. *J. Sci. Food Agr.* 16, 425-432.
- Hernández, M.D., Egea, M.A., Rueda, F.M., Aguado, F., Martínez, F.J., García, B. (2001)** Effects of commercial diets with different P/E ratios on sharpnose seabream (*Diplodus puntazzo*) growth and nutrient utilization. *Aquaculture* 195, 321–329.
- Hertrampf, J.W., Piedad-Pascual, F. (2000)** *Handbook on Ingredients for Aquaculture Feeds*. Kluwer Academic Publishers, Boston, USA, 573 pp.
- Heu, M-S., Kim, J-S., Shahidi, F. (2003)** Components and nutritional quality of shrimp processing by-products. *Food Chemistry* 82, 235-242.
- Hidalgo, M.C., Urea, E., Sanz, A. (1999)** Comparative study of digestive enzymes in fish with different nutritional habits. Proteolytic and amylase activities. *Aquaculture* 170, 267-283.
- Higgs, D.A., Dosanjh, B.S., Prendergast, A.F., Beames, R.M., Hardy, R.W., Riley, W., Deacon, G. (1995)** Use of rapeseed/canola protein products in finfish diets. In: *Nutrition and Utilization Technology in Aquaculture* (ed. by D. Sessa and C. Lim), pp. 130-156. AOCS Press, Champaign, FL, USA.
- Hilton, J.W., Slinger, S.J. (1986)** Digestibility and utilization of canola meal in practical-type diets for rainbow trout (*Salmo gairdneri*). *Canadian Journal of Fisheries and Aquatic Sciences* 43, 1149-1155.
- Hirano, S., Itakura, C., Seino, H., Akiyama, Y., Nonaka, I., Kanbara, N., Kawakami, T. (1990)** Chitosan as an ingredient for domestic animal feeds. *J. Agric. Food Chem.* 38, 1214-1217.

- Horwood, J., O'Brien, C., Darby, S. (2006)** North Sea cod recovery? ICES Journal of Marine Science 63, 961-968.
- Hossain, M.A., Nahar, N., Kamal, M. (1997)** Nutrient digestibility coefficients of some plant and animal proteins for rohu (*Labeo rohita*). Aquaculture 151, 37-45.
- Houlihan, D.F., Carter, C.G., McCarthy, I.D. (1995)** Protein synthesis in fish. In: Mommsen, H.A. (ed.) Biochemistry and Molecular Biology of Fishes. Elsevier Science B.V., pp. 191-219.
- Houlihan, D., Boujard, T., Jobling, M. (2001)** Food Intake in Fish. Blackwell Science Ltd., Oxford, UK, 418 p.
- Hsu, H.W., Vavak, D.L., Satterlee, L.D., Miller, G.A. (1977)** A multienzyme technique for estimating protein digestibility. J. Food Sci. 42, 1269-1273.
- Hutchings, J.A., Minto, C., Ricard, D., Baum, J.K., Jensen, O.P. (2010)** Trends in the abundance of marine fishes. Can. J. Fish. Aquat. Sci. 67, 1205-1210.
- Huxley, T.H. (1884)** Inaugural address of the Fishery Conferences. Fisheries Exhibition Literature 4, 18.
- Jaguelin, Y., Fevrier, C., Seve, B., Lechevestrier, Y., Mariscal-Landin, G., Leroux, P., Lebreton, W. (1994)** *In vitro* method for evaluation of apparent and true nitrogen digestibility of pig feedstuffs, in: Souffrant, W.B., Hagemester, H. (Eds.), Proceedings of the Sixth International Symposium on Pig Digestive Physiology, EAAP. Translated by Sichuan Agricultural University, Sichuan Science and Technology Press, China, 1997, pp. 116-119.
- Jeuniaux, H. (1966)** Chitinases, in: Colowick, S.P., Kaplan, N.O. (Eds.), Methods in Enzymology, Academic Press, London, UK. 644 p.
- Jobling, M. (1981)** Dietary digestibility and the influence of food components on gastric evacuation in plaice *Pleuronectes platessa* L. Journal of Fish Biology 19, 29-36.
- Jobling, M. (1988)** A review of the physiological and nutritional energetics of cod, *Gadus morhua* L., with particular reference to growth under farmed conditions. Aquaculture 70, 1-19.
- Jobling, M. (1994)** Fish Bioenergetics. Chapman and Hall Publishing Co., New York, NY, 309 p.
- Jobling, M., Knudsen, R., Pedersen, P.S., Dos Santos, J. (1991)** Effects of dietary composition and energy content on the nutritional energetics of cod, *Gadus morhua*. Aquaculture, 92, 243-257.
- Jóhannsdóttir, U.B. (2009)** Activity of Atlantic cod trypsin towards cytokines and other proteins. M.Sc. Thesis, University of Iceland, 53 pp.
- Johnson, D. (1988)** Crab meal as a feed for hogs. Economic and Regional Development Agreement for Prince Edward Island - Prince Edward Island Agri-Food Development Sub-Agreement. Project Report - Technology Development Program, 53 pp.
- Johnson, H.M. (2008)** Balancing future seafood supply – Demand in a global economy. Global Aquaculture Advocate 11, 22-24.
- Jørgensen, S.E. (1995)** State of the art of ecological modelling in limnology. Ecol. Model. 78, 101-115.
- Jürs, K., Bittorf, T.H., Vökler, T.H. (1985)** Influence of salinity and ratio of lipids to protein in diets of certain enzyme activities in rainbow trout. Comp. Biochem. Physiol. 81B, 73-79.

- Kaushik, S.J. (1998)** Nutritional bioenergetics and estimation of waste production in non-salmonids. *Aquat. Living Resour.* 11, 211-217.
- Kabir, N.M.J., Wee, K.L., Maguire, G. (1998)** Estimation of apparent digestibility coefficients in rainbow trout (*Oncorhynchus mykiss*) using different markers. 1. Validation of microtracer F-Ni as a marker. *Aquaculture* 167, 259-272.
- Kaushik, S.J., de Oliva-Teles, A. (1985)** Effect of digestible energy on nitrogen and energy balance in rainbow trout. *Aquaculture* 50, 89-101.
- Kaushik, S.J., Cowey, C.Y. (1991)** Dietary factors affecting nitrogen excretion by fish. In: C.B. Cowey, Cho, C.Y. (eds.) *Nutritional Strategies and Aquaculture Waste. Proceedings of the 1<sup>st</sup> International Symposium on Nutritional Strategies in Management of Aquaculture Waste*, Guelph, ON, pp. 3-19.
- Kaushik, S.J., Cravedi, J.P., Lalles, J.P., Sumpter, J., Fauconneau, B., Laroche, M. (1995)** Partial or total replacement of fishmeal by soybean protein on growth, protein utilization, potential estrogenic or antigenic effects, cholesterolemia and flesh quality in rainbow trout. *Aquaculture* 133, 257-274.
- Kaushik, S.J., Seiliez, I. (2010)** Protein and amino acid nutrition and metabolism in fish: current knowledge and future needs. *Aquaculture Research* 41, 322-332.
- Kiliç Apar, D., Özbek, B. (2010)** Corn gluten hydrolysis by Alcalase: Calibration of pH-stat. *Food Bioprod. Process.* 32, 1-4.
- Kim, J.D., Lall, S.P. (2001)** Effects of dietary protein level on growth and utilization of protein and energy by juvenile haddock (*Melanogrammus aeglefinus*). *Aquaculture* 195, 311-319.
- Kim, J.D., Lall, S.P., Milley, J.E. (2001)** Dietary protein requirements of juvenile haddock (*Melanogrammus aeglefinus* L.). *Aquacult. Res.* 32, 1-7.
- Kim, J.D., Tibbetts, S.M., Milley, J.E., Lall, S.P. (2006)** Effect of the incorporation level of herring meal into test diet on apparent digestibility coefficients for protein and energy by juvenile haddock, *Melanogrammus aeglefinus* L. *Aquaculture* 258, 479-486.
- Kim, J.D., Tibbetts, S.M., Milley, J.E., Lall, S.P. (2007)** Effect of the incorporation level of dehulled soybean meal into test diet on apparent digestibility coefficients for protein and energy by juvenile haddock, *Melanogrammus aeglefinus* L. *Aquaculture* 267, 308-314.
- Kjesbu, O.S., Taranger, G.L., Trippel, E.A. (2006)** Gadoid mariculture: Development and future challenges. *ICES Journal of Marine Science* 63, 187-191.
- Koeleman, E. (2009)** Aquaculture takes environment seriously. *Feed Tech: International Feed Production and Applied Nutrition* 13, 29-31.
- Kofuji, P.Y.M., Akimoto, A., Hosokawa, H., Masumoto, T. (2005)** Seasonal changes in proteolytic enzymes of yellowtail *Seriola quinqueradiata* (Temminck & Schlegel; Carangidae) fed extruded diets containing different protein and energy levels. *Aquaculture Research* 36, 696-703.
- Kolakowski, E. (1986)** Changes of non-protein nitrogens fractions in Antarctic krill (*Euphausia superba* Dana) during storage at 3° and 20°C. *Z. Lebensm Unters Forsch* 183, 421-425.

- Kora, H., Osato, S., Miyata, K., Wu, Z., Tachibana, K., Tsuchimoto, M. (1995)** Changes in amounts of fat, water, protein and ash in whole body of cultured red sea bream with growth and comparison with wild bream. *Nippon Suissan Gakkaishi* 61, 211-218.
- Kristinsson, H.J., Rasco, B.A. (2000)** Hydrolysis of salmon muscle proteins by an enzyme mixture extracted from Atlantic salmon (*Salmo salar*) pyloric caeca. *J. Food Biochem.* 24, 177-187.
- Kristjánsson, M.M. (1991)** Purification and characterization of trypsin from the pyloric caeca of rainbow trout (*Orcorhynchus mykiss*). *J. Agric. Food Chem.* 39, 1738-1742.
- Krogdahl, Å. (1991)** Alternative protein sources from plants contain antinutrients affecting digestion in salmonids. In: *Current Status of Fish Nutrition in Aquaculture. Proceedings of the IV International Symposium on Nutrition and Feeding of Fish* (ed. by M. Takeda and T. Watanabe), pp. 253-261. Tokyo University of Fisheries, Japan.
- Krogdahl, Å., Penn, M., Thorsen, J., Refstie, S., Bakke, A.M. (2010)** Important antinutrients in plant feedstuffs for aquaculture: an update on recent findings regarding responses in salmonids. *Aquaculture Research* 41, 333-344.
- Kumar, M.N.V.R. (2000)** A review of chitin and chitosan applications. *Reactive and Functional Polymers* 46, 1-27.
- Kurlansky, M. (1997)** *Cod: A Biography of the Fish that Changed the World*. Alfred A. Knopf Canada Publishing, Toronto, ON. 294 p.
- Kuz'mina, V.V., Gelman, A.G. (1997)** Membrane-linked digestion in fish. *Rev. Fish. Sci.* 5, 99-129.
- Lainé, J., Beattie, M., LeBel, D. (1993)** Simultaneous kinetic determinations of lipase, chymotrypsin, trypsin, elastase and amylase on the same microtiter plate. *Pancreas* 8, 383-386.
- Lall, S.P. (1991)** Concepts in the formulation and preparation of a complete fish diet. In: *Fish Nutrition Research in Asia. Proceedings of the Fourth Asian Fish Nutrition Workshop*. Asian Fisheries Society Special Publication 5 (ed. by S.S. De-Silva), pp. 1-12. Asian Fisheries Society, Manila, Philippines, 205 pp.
- Lall, S., Parazo, M. (1995)** Vitamins in fish and shellfish. In: *Ruiter, A. (ed.) Fish and Fishery Products: Composition, Nutritive Properties and Stability*, CABI, Oxford, pp. 157-186.
- Lall, S.P., Nanton, D. (2002)** Nutrition of Atlantic cod. *Bull. Aquac. Assoc. Can.* 102-1, 23-26.
- Lall, S.P., Anderson, S. (2005)** Amino acid nutrition of salmonids: Dietary requirements and bioavailability. In: *Montero, D., Basurco, B., Nengas, I., Alexis, M., Izquierdo, M. (eds.) Cahiers Options Méditerranéens, CIHEAM, Zaragoza, Spain*, pp. 73-90.
- Lall, S.P., Tibbetts, S.M. (2009)** Nutrition, feeding, and behaviour of fish. In: *Hess, L., Antinoff, N. (Eds.), Nutrition and Behaviour of Uncommon Species*, *Vet. Clin. N. American - Exot. Anim. Pract.* 12, 361-372.
- Lall, S.P., Nanton, D.A., Tibbetts, S.M., Roy, P.K., Milley, J.E. (2003)** Nutrient requirements and feeding of haddock. In: *Aiken, D.E. (ed.) Early Rearing of Haddock: State of the Art*. Aquaculture Association of Canada, Special Publication Number 7, 79-86.

- Lan, C.C., Pan, B.S. (1993)** *In vitro* digestibility simulating the proteolysis of feed protein in the midgut gland of grass shrimp (*Penaeus monodon*). Aquaculture 109, 59-70.
- Lanari, D., Poli, B.M., Ballestrazzi, R., Lupi, P., D'Agaro, E., Mecatti, M. (1999)** The effects of dietary fat and NFE levels on growing European sea bass (*Dicentrarchus labrax* L.). Growth rate, body and fillet composition, carcass traits and nutrient retention efficiency. Aquaculture 179, 351-364.
- Lanteigne, C., Leadbeater, S. (2003)** Haddock culture in Atlantic Canada. Hatchery International 4, 14-17.
- Lavigne, C., Tremblay, F., Asselin, G., Jacques, H., Marette, A. (2001)** Prevention of skeletal muscle insulin resistance by dietary cod protein in high fat-fed rats. Am. J. Physiol. Endocrinol. Metab. 281, 62-71.
- Lee, S.M. (2002)** Apparent digestibility coefficients of various feed ingredients for juvenile and grower rockfish (*Sebastes schlegeli*). Aquaculture 207, 79-95.
- Lee, S.M., Jeon, I.G., Lee, J.Y. (2002)** Effects of digestible protein and lipid levels in practical diets on growth, protein utilization and body composition of juvenile rockfish (*Sebastes schlegeli*). Aquaculture 211, 227-239.
- Lee, D.J., Putnam, G.B. (1973)** The response of rainbow trout to varying protein/energy ratios in a test diet. J. Nutr. 103, 916-922.
- Leenhouders, J.I., Adjei-Boateng, D., Verreth, J.A.J., Schrama, J.W. (2006)** Digesta viscosity, nutrient digestibility and organ weights in African catfish (*Clarias gariepinus*) fed diets supplemented with different levels of a soluble non-starch polysaccharide. Aquaculture Nutrition 12, 111-116.
- Lemieux, H., Blier, P., Dutil, J.D. (1999)** Do digestive enzymes set a physiological limit on growth rate and food conversion efficiency in the Atlantic cod (*Gadus morhua*)? Fish Physiol. Biochem. 20, 293-303.
- Lemos, D., Nunes, A.J.P. (2008)** Prediction of culture performance of juvenile *Litopenaeus vannamei* by *in vitro* (pH-stat) degree of feed protein hydrolysis with species-specific enzymes. Aquaculture Nutrition 14, 181-191.
- Lemos, D., Lawrence, A.L., Siccardi III, A.J. (2009)** Prediction of apparent protein digestibility of ingredients and diets by *in vitro* pH-stat degree of protein hydrolysis with species-specific enzymes for juvenile Pacific white shrimp *Litopenaeus vannamei*. Aquaculture 295, 89-98.
- Lemos, D., Tacon, A.G.J. (2011)** A rapid low-cost laboratory method for measuring the *in vitro* protein digestibility of feed ingredients and feeds for shrimp. Aquaculture Asia Pacific 7, 18-21.
- Li, M.H., Robinson, E.H., Hardy, R.W. (2000)** Protein sources for feeds. In: Encyclopedia of Aquaculture (ed. by R.R. Stickney), pp. 688-695. John Wiley and Sons, New York, NY, USA.
- Lie Ø., Lied E., Lambertsen G. (1986)** Liver retention of fat and fatty acids in cod (*Gadus morhua*) fed different oils. Aquaculture 59, 187-196.
- Lie Ø., Lied E., Lambertsen G. (1988)** Feed optimization in Atlantic cod (*Gadus morhua*): fat versus protein content in the feed. Aquaculture 69, 333-341.



- Lie, Ø., Lied, E., Lambertsen, G. (1990)** Haematological values in cod (*Gadus morhua*). Fisk. Dir. Skr. Ser. Eraering, 3III, 11-17.
- Lie, K.K., Hansen, A.C., Eroldogan, O.T., Olsvik, P.A., Rosenlund, G., Hemre, G.I. (2011)** Expression of genes regulating protein metabolism in Atlantic cod (*Gadus morhua* L.) was altered when including high diet levels of plant proteins. *Aquaculture Nutrition* 17, 33-43.
- Lim, C., Webster, C.D., Lee, C.S. (2008)** *Alternative Protein Sources in Aquaculture Diets*. Haworth Press, New York, NY, USA.
- Lindsay, G.J.H., Walton, M.J., Adron, J.W., Fletcher, T.C., Cho, C.Y., Cowey, C.B. (1984)** The growth of rainbow trout (*Salmo gairdneri*) given diets containing chitin and its relationship to chitinolytic enzymes and chitin digestibility. *Aquaculture* 37, 315-324.
- Lovell, T. (1989)** *Nutrition and Feeding of Fish*. Van Nostrand Reinhold, New York, NY, pp. 88-89.
- Lupatsch, I., Kissil, G.W., Sklan, D., Pfeffer, E. (1997)** Apparent digestibility coefficients of feed ingredients and their predictability in compound diets for gilthead seabream, *Sparus aurata* L. *Aquaculture Nutrition* 3, 81-89.
- Lupatsch, I., Kissil, G. Wm., Sklan, D., Pfeffer, E. (1998)** Energy and protein requirements for maintenance and growth in gilthead seabream. *Aquaculture Nutrition* 4, 165–173.
- Lupatsch, I., Kissil, G. Wm., Sklan, D., Pfeffer, E. (2001)** Effects of varying dietary protein and energy supply on growth, body composition and protein utilization in gilthead seabream (*Sparus aurata* L.). *Aquaculture Nutrition* 7, 71–80.
- Maga, J.A., Lorenz, K., Onayemi, O. (1973)** Digestive acceptability of proteins as measured by the initial rate of *in vitro* proteolysis. *J. Food Sci.* 38, 173-174.
- Manchester, K.L. (1977)** Hormonal control of protein metabolism. In: Cole, D.J.A. (ed.) *Protein Metabolism and Nutrition*. Butter-Worth, London, UK, pp. 35-47.
- Marletta, L., Carbonaro, L., Carnovale, E. (1992)** *In vitro* protein and sulphur amino acid availability as a measure of bean protein quality. *J. Sci. Food Agricult.* 59, 497-504.
- Maynard, L.A., Loosli, J.K. (1969)** *Animal Nutrition*, 6th edn. McGraw-Hill, New York, NY, USA, 613 pp.
- Maynard, L.A., Loosli, J.K., Hintz, H.F., Warner, R.G. (1979)** *Animal Nutrition*, 7th Edition. McGraw-Hill, New York. 603 pp.
- McGoogan, B.B., Reigh, R.C. (1996)** Apparent digestibility of selected ingredients in red drum (*Sciaenops ocellatus*) diets. *Aquaculture* 141, 233-244.
- Médale, F., Aguirre, P., Kaushik, S.J. (1991)** Utilization of dietary carbohydrates at two water temperatures. In: Wenk, C., Boessinger, M. (eds.) *Energy Metabolism of Farm Animals*. EAAP Publication No. 58. Institut für Nutztierwissenschaften, Gruppe Ernährung, Zürich, Switzerland.
- Mommsen, T.P., Plisetskaya, E.M. (1991)** Insulin in fishes and agnathans: history, structure and metabolic regulation. *Rev. Aquat. Sci.* 4, 225–259.

- Mommsen, T.P., Moon, T.W. (2001)** Hormonal regulation of muscle growth. In: Johnston, I.A. (ed.) Muscle Development and Growth. Academic Press, San diego, CA, pp. 251-308.
- Morais, S., Bell, J.G., Robertson, D.A., Roy, W.J., Morris, P.C. (2001)** Protein/lipid ratios in extruded diets for Atlantic cod (*Gadus morhua* L.): effects on growth, feed utilization, muscle composition and liver histology. Aquaculture 203, 101-119.
- Morales, A.E., Cardenete, G., Sanz, A., de la Higuera, M. (1999)** Re-evaluation of crude fibre and acid-insoluble ash as inert markers, alternatives to chromic oxide, in digestibility studies with rainbow trout (*Oncorhynchus mykiss*). Aquaculture 179, 71–79.
- Morales, G.A., Moyano, F.J. (2010)** Application of an *in vitro* gastrointestinal model to evaluate nitrogen and phosphorous bioaccessibility and bioavailability in fish feed ingredients. Aquaculture 306, 244-251.
- Moran Jr., E.T., Summers, J.D., Slinger, S.J. (1966)** Keratin as a source of protein for the growing chick. 1. Amino acid imbalance as the cause for inferior performance of feather meal and the implication of disulfide bonding in raw feathers as the reason for poor digestibility. Poult. Sci. 45, 1257-1266.
- Morris, C.J., Green, J.M. (2002)** Biological characterization of a resident population of Atlantic cod (*Gadus morhua* L.), in southern Labrador. ICES J. Mar. Sci. 59, 666–678.
- Muzzarelli, R.A.A. (1977)** Chitin. Pergamon Press, Oxford, UK, 309 pp.
- Mwachireya, S.A., Beames, R.M., Higgs, D.A., Dosanjh, B.S. (1999)** Digestibility of canola protein products derived from the physical, enzymatic and chemical processing of commercial canola meal in rainbow trout, *Oncorhynchus mykiss* (Walbaum), held in freshwater. Aquaculture Nutrition 5, 73-82.
- National Research Council (1981)** Nutrient Requirements of Coldwater Fishes. National Academy Press, Washington, DC, USA., 63 p.
- National Research Council (1993)** Nutrient Requirements of Fish. National Academy Press, Washington, DC, USA, 114 p.
- National Research Council (2011)** Nutrient Requirements of Fish and Shrimp. National Academy Press, Washington, DC, USA, 376 p.
- Nanton D.A. (2002)** Lipid Metabolism of Haddock (*Melanogrammus aeglefinus*). PhD Thesis, Atlantic Veterinary College, University of Prince Edward Island, PEI, Canada. 182 pp.
- Nanton, D.A., Lall, S.P., McNiven, M.A. (2001)** Effects of dietary lipid level on liver and muscle deposition in juvenile haddock, *Melanogrammus aeglefinus* L. Aquaculture Research 32, 225-234.
- Nanton, D.A., Lall, S.P., Ross, N.W., McNiven, M.A. (2003)** Effect of dietary lipid level on fatty acid  $\beta$ -oxidation and lipid composition in various tissues of haddock, *Melanogrammus aeglefinus* L. Comp. Biochem. Physiol. 135B, 95-108.
- Naylor, R.L., Goldburg, R.J., Primavera, J.H., Kautsky, N., Beveridge, M.C.M., Clay, J., Folke, C., Lubchenco, J., Mooney, H., Troell, M. (2000)** Effect of aquaculture on world fish supplies. Nature 405, 1017-1024.

- Naylor, R.L., Hardy, R.W., Bureau, D.P., Chiu, A., Elliot, M., Farrell, A.P., Forster, I., Gatlin, D.M., Goldburg, R.J., Hua, K., Nichols, P.D. (2009)** Feeding aquaculture in an era of finite resources. *Proceedings of the National Academy of Sciences* 106, 15103-15110.
- Nengas, I., Alexis, M.N., Davies, S.J., Petichakis, G. (1995)** Investigation to determine digestibility coefficients of various raw materials in diets for gilthead seabream, *Sparus auratus* L. *Aquaculture Research* 26, 185-194.
- New, M.B., Wijkström, U.N. (2002)** Use of Fish meal and Fish oil in Aquafeeds: Further Thoughts on the Fish meal Trap. FAO Fish Circ. No. 975. FAO, Rome, Italy.
- Nordøy, E.S., Sørma, W., Blix, A.S. (1993)** *In vitro* digestibility of different prey species of minke whales (*Balaenoptera acutorostrata*). *Brit. J. Nutr.* 70, 485-489.
- Norwegian Directorate of Fisheries – Statistical Services** (<http://www.fiskeridir.no/english/statistics/norwegian-aquaculture/aquaculture-statistics/cod>) accessed on November 25, 2010.
- O'Hare, W.T., Curry, M.C., Allen, J.C. (1984)** Effect of buffering capacity on a commonly used assay of protein digestibility. *J. Food Sci.* 49, 498-499.
- Olli, J.J., Krogdahl, Å. (1995)** Alcohol soluble components of soybeans seem to reduce fat digestibility in fish-meal based diets for Atlantic salmon, *Salmo salar* L. *Aquaculture Research* 26, 831-835.
- Olsen, R.E., Ringø, E. (1998)** The influence of temperature on the apparent nutrient and fatty acid digestibility of Arctic charr, *Salvelinus alpinus* L. *Aquaculture Research* 29, 695-701.
- Olsen, R.E., Hansen, A.C., Rosenlund, G., Hemre, G.I., Mayhew, T.M., Knudsen, D.L., Eroldoğan, O.T., Myklebust, R., Karlsten, Ø. (2007)** Total replacement of fish meal with plant proteins in diets for Atlantic cod (*Gadus morhua* L.) II – Health aspects. *Aquaculture* 272, 612-624.
- Owusu-Ansah, Y.J., McCurdy, S.M. (1991)** Pea proteins: a review of chemistry, technology of production, and utilization. *Food Rev. Int.* 7, 103–134.
- Paisley, L.G., Ariel, E., Lyngstad, T., Jónsson, G., Vennerström, P., Hellström, A., Østergaard, P. (2010)** An overview of aquaculture in the Nordic countries. *Journal of the World Aquaculture Society* 41, 1-17.
- Papatryphon, E., Soares, J.H. Jr (2001)** The effect of phytase on apparent digestibility of four practical plant feedstuffs fed to striped bass, *Morone saxatilis*. *Aquaculture Nutrition* 7, 161-167.
- Pauly, D. (1996)** One hundred million tonnes of fish, and fisheries research. *Fisheries Research* 25, 25-38.
- Pauly, D., Watson, R., Alder, J. (2005)** Global trends in world fisheries: impacts on marine ecosystems and food security. *Proceedings of the Royal Society of London, Series B Biological Sciences* 360, 5-12.
- Peach, R.W. (2005)** Protein and energy utilization by juvenile Atlantic halibut (*Hippoglossus hippoglossus*). M.Sc. Thesis. Dalhousie University, Halifax/Nova Scotia Agricultural College, Truro, Nova Scotia, 133 pp.
- Pedersen, B., Eggum, B.O. (1983)** Prediction of protein digestibility by an *in vitro* enzymatic pH-stat procedure. *J. Anim. Physiol. Anim. Nutr.* 49, 265-277.

- Peres, H., Oliva-Teles, A. (1999)** Effect of dietary lipid level on growth performance and feed utilization by European sea bass juveniles (*Dicentrarchus labrax*). *Aquaculture* 179, 325–334.
- Peres, H., Oliva-Teles, A. (2001)** Effect of dietary protein and lipid level on metabolic utilization of diets by European sea bass (*Dicentrarchus labrax*) juveniles. *Fish Physiol. Biochem.* 25, 269-275.
- Pérez-Jiménez, A., Cardenete, G., Morales, A.E., García-Alcázar, A., Abellán, E., Hidalgo, M.C. (2009)** Digestive enzymatic profile of *Dentex dentex* and response to different dietary formulations. *Comp. Biochem. Physiol.* 154A, 157-164.
- Pfeffer, E. (1982)** Utilization of dietary protein by salmonid fish. *Comparative Biochemistry and Physiology* 73B, 51-57.
- Pickova, J., Mørkøre, T. (2007)** Alternate oils in fish feeds. *Eur. J. Lipid Sci. Technol.* 109, 256-263.
- Pierce Biotechnology Inc. (2010)** [www.piercenet.com](http://www.piercenet.com) 2010 (accessed on January 5).
- Pike, I.H. (1991)** Freshness of fish for fish meal—effect of growth on salmon. In: Kaushik, S.J., Luquet, P. (eds.), *Fish Nutrition in Practice. Les Colloques*, vol. 61. INRA, Paris, pp. 843–846.
- Pike, I.H., Andorsdottir, G., Mundheim, H. (1990)** The Role of Fish Meal in Diets for Salmonids, No. 24. International Association of Fish Meal Manufacturers, Hertfordshire, UK, 35 pp.
- Plisetskaya, E.M., Mommsen, T.P. (1996)** Glucagon and glucagon-like peptides in fishes. *Int. Rev. Cytol.* 168, 187-257.
- Post, G., Shanks, W.E., Smith, R.R. (1965)** A method for collecting metabolic excretions from fish. *Prog. Fish Cult.* 27, 108-111.
- Powell, K. (2003)** Eat your veg. *Nature* 426, 378-379.
- Price, K.R., Griffiths, N.M., Curl, C.L., Fenwick, G.R. (1985)** Undesirable sensory properties of the dried pea (*Pisum sativum*). The role of saponins. *Food Chem.* 17, 105–115.
- Quaglia, G.B., Orban, E. (1987)** Enzymatic solubilisation of proteins of sardine (*Sardina pilchardus*) by commercial proteases. *J. Sci. Food Agric.* 38, 263-269.
- Raae, A.J., Walther, B.T. (1989)** Purification and characterization of chymotrypsin, trypsin and elastase like proteinases from cod (*Gadus morhua* L.). *Comp. Biochem. Physiol.*, 93B, 317-324.
- Rathmacher, J.A. (2000)** Measurement and significance of protein turnover. In: D’Mello, J.P.F. (ed.) *Farm Animal Metabolism and Nutrition*. CABI Publishing, Wallingford, UK, pp. 25-47.
- Refstie, S., Helland, S.J., Storebakken, T. (1997)** Adaptation to soybean meal in diets for rainbow trout, *Oncorhynchus mykiss*. *Aquaculture* 153, 263-272.
- Refstie, S., Svihus, B., Shearer, K.D., Storebakken, T. (1999)** Nutrient digestibility in Atlantic salmon and broiler chickens related to viscosity and non-starch polysaccharide content in different soybean products. *Anim. Feed Sci. Technol.* 79, 331-345.

- de Rodrigáñez, M.A.S., Medina, M., Moyano, F.J., Alarcón, F.J. (2011)** Evaluation of protein hydrolysis in raw sources by digestive proteases of Senegalese sole (*Solea senegalensis*, Kaup 1858) using a combination of an *in vitro* assay and sodium dodecyl sulphate polyacrylamide gel electrophoresis analysis of products. *Aquaculture Research*, doi:10.1111/j.1365-2109.2010.02758.x.
- Refstie, S., Korsøen, Ø.J., Storebakken, T., Bæverfjord, G., Lein, I., Roem, A.J. (2000)** Differing nutritional responses to dietary soybean meal in rainbow trout (*Oncorhynchus mykiss*) and Atlantic salmon (*Salmo salar*). *Aquaculture* 190, 49-63.
- Refstie, S., Landsverk, T., Bakke-McKellep, A.M., Ringø, E., Sundby, A., Shearer, K.D., Krogdahl, Å. (2006)** Digestive capacity, intestinal morphology, and microflora of 1-year and 2-year old Atlantic cod (*Gadus morhua*) fed standard or bioprocessed soybean meal. *Aquaculture* 261, 269-284.
- Regost, C., Arzel, J., Kaushik, S.J. (1999)** Partial or total replacement of fish meal by corn gluten meal in diet for turbot (*Psetta maxima*). *Aquaculture* 180, 99–117.
- Ricker, W.E. (1979)** Growth rates and models. In: *Fish Physiology* (Hoar, W.S., Randall D.J. and Brett J.R. eds), pp. 677–743. Academic Press, New York.
- Robaina, L., Corraze, G., Aguirre, P., Blanc, D., Melcion, J.P., Kaushik, S. (1999)** Digestibility, post-prandial ammonia excretion and selected plasma metabolites in European sea bass (*Dicentrarchus labrax*) fed pelleted or extruded diets with or without wheat gluten. *Aquaculture* 179, 45–56.
- Rodehutscord, M., Pfeffer, E. (1999)** Maintenance requirement for digestible energy and efficiency of utilization of digestible energy for retention in rainbow trout, *Oncorhynchus mykiss*. *Aquaculture* 179, 95–107.
- Rose, G.A. (2007)** *Cod: The Ecological History of the North Atlantic Fisheries*. Breakwater Books Ltd., St. John's, NL. 591 p.
- Rosenlund, G., Karlsen, Ø., Tveit, K., Mangor-Jensen, A., Hemre, G.I. (2004)** Effect of feed composition and feeding frequency on growth, feed utilization and nutrient retention in juvenile Atlantic cod, *Gadus morhua* L. *Aquaculture Nutrition* 10, 371-378.
- Rosenlund, G., Skretting, M. (2006)** Worldwide status and perspective on gadoid culture. *ICES Journal of Marine Science* 63, 194-197.
- Rothenbuhler, E., Kinsella, J.E. (1985)** The pH-Stat method for assessing protein digestibility: An evaluation. *J. Agric. Food Chem.* 33, 433-438.
- Roy, P.K., Lall, S.P. (2003)** Dietary phosphorous requirement of juvenile haddock (*Melanogrammus aeglefinus* L.). *Aquaculture* 221, 451-468.
- Roy, P.K., Lall, S.P., Harvey-Clark, C. (2004)** A cannulation technique for urine collection from haddock, *Melanogrammus aeglefinus* L. *Aquaculture Research* 35, 87-92.
- Rust, M.B. (2002)** Nutritional physiology. In: Halver, J.E., Hardy, R.W. (eds.) *Fish Nutrition*, 3rd Edition. Academic Press, New York, USA. pp. 367-452.

- Ruxton, C.H.S., Reed, S.C., Simpson, M.J.A., Millington, K.J. (2007)** The health benefits of omega-3 polyunsaturated fatty acids: a review of the evidence. *J. Hum. Dietet.* 20, 275–285.
- Ruzzin, J., Turcotte, S., Leblanc, V., Lavigne, C., Froyland, L., Remman, T.R., Marette, A. (2007)** Dietary salmon protein improves insulin sensitivity in high-fat fed obese rats. *Ann. Nutr. Metab.*, 51, 347.
- Rychly, J. (1980)** Nitrogen balance in trout. II. Nitrogen excretion and retention after feeding diets with varying protein and carbohydrate levels. *Aquaculture* 20, 343-350.
- Santerre, C.R. (2010)** The risks and benefits of farmed fish. *Journal of the World Aquaculture Society* 41, 250-257.
- Sandnes, K., Lie, Ø., Waagbø, R. (1988)** Normal ranges of some blood chemistry parameters in adult farmed Atlantic salmon (*Salmo salar*). *J. Fish Biol.* 32, 129-136.
- Sargent, J.R. (1997)** Fish oils and human diet. *British Journal of Nutrition* 78, 5-13.
- Sargent, J.R., Tacon, A.G.J. (1999)** Development of farmed fish: a nutritionally necessary alternative to meat. *Proc. Nutr. Soc.* 58, 377-383.
- Satterlee, L.D., Marshall, H.F., Tennyson, J.M. (1979)** Measuring protein quality. *J. Am. Oil Chem. Soc.* 56, 103-109.
- Savoie, L. (1994)** Digestion and absorption of food: usefulness and limitations of *in vitro* models. *Can. J. Physiol. Pharmacol.* 72, 407-413.
- Scott, W.B., Scott, M.G. (1988)** Atlantic Fishes of Canada. *Can. Bull. Fish. Aquat. Sci.* 219, 731 p.
- Shahidi, F., Kamil, Y.V.A.K. (2001)** Enzymes from fish and aquatic invertebrates and their application in the food industry. *Trends Food Sci. Technol.* 12, 435-464.
- Shearer, K.D. (1994)** Factors affecting the proximate composition of cultured fishes with emphasis on salmonids. *Aquaculture* 119, 63-88.
- Sheffner, A.L., Eckfeld, G.A., Spektor, H. (1956)** The pepsin-digest-residue (PDR) amino acid index of net protein utilization. *J. Nutr.* 60, 105-111.
- Shipton, T.A., Britz, P.J. (2002)** Evaluation of an *in vitro* digestibility technique for the prediction of protein digestibility in the South African abalone, *Haliotis midae* L. *Aquaculture Nutrition* 8, 15-21.
- Sigurgisladdottir, S., Lall, S., Parrish, C.C., Ackman, R.G. (1992)** Cholestane as a digestibility marker in the absorption of polyunsaturated fatty acid ethyl esters in Atlantic salmon. *Lipids* 27, 418-424.
- da Silva, G.J., Oliva-Teles, A. (1998)** Apparent digestibility coefficients of feedstuffs in seabass (*Dicentrarchus labrax*) juveniles. *Aquat. Living Resour.* 11, 187–191.
- Simpson, B.K., Haard, N.F. (1984)** Trypsin from Greenland cod, *Gadus ogac*. Isolation and comparative properties. *Comp. Biochem. Physiol.* 79B, 613-622.
- Simpson, B.K., Haard, N.F. (1987)** Trypsin and a trypsin enzyme from the stomachless cunner. Catalytic and other physical characteristics. *J. Agric. Food Chem.* 35, 652-656.
- Simpson, B.K., Simpson, M.V., Haard, N.F. (1990)** Properties of trypsin from the pyloric caeca of Atlantic cod (*Gadus morhua*). *J. Food Sci.* 55, 959-961.

- Small, B.C., Austic, R.E., Soares, J.H. Jr (1999)** Amino acid availability of four practical feed ingredients fed to striped bass *Morone saxatilis*. *Journal of the World Aquaculture Society* 30, 58-64.
- Smith, L.S. (1989)** Digestive functions in teleost fishes. In: Halver, J.E. (ed.). *Fish Nutrition* 2<sup>nd</sup> edition, Academic Press, San Diego, CA., pp. 331-421.
- Smith, R.R. (1971)** A method for measuring digestibility and metabolizable energy of fish feeds. *Prog. Fish Cult.* 33, 132-134.
- Smith, R.R., Peterson, M.C., Allred, A.C. (1980)** The effect of leaching on apparent digestion coefficients in determining digestibility and metabolizable energy of feedstuffs for salmonids. *Progressive Fish Culturist* 42, 195-199.
- Somsueb, P. (1993)** Aquafeeds and feeding strategies in Thailand. In: *Proceedings of the Regional Expert Consultation on Farm-Made Aquafeeds, 14-18 December 1992, FAO-RAPA/AADCP, Bangkok, Thailand, 14-18 December 1994* (ed. by FAO-RAPA/AADCP), pp. 365-385.
- Squires, J., Haard, N.F., Feltham, L.A.W. (1986)** Pepsin isozymes from Greenland cod (*Gadus ogac*). 2. Substrate specificity and kinetic properties. *Can. J. Biochem. Cell Biol.* 65, 215-222.
- Standal, D., Utne, I.B. (2007)** Can cod farming affect cod fishing? A system evaluation of sustainability. *Marine Policy* 31, 527-534.
- Steel, R.G.D., Torrie, J.H. (1960)** *Principles and Procedures of Statistics*. McGraw-Hill Book Company, Inc., New York.
- Steffens, W. (1989)** *Principles of Fish Nutrition*. Ellis Harwood, Chichester, UK, 384 p.
- Stinson, C.T., Snyder, H.E. (1980)** Evaluation of heated soy flours by measurement of tryptic hydrolysis using a pH Stat. *Food Sci.* 45, 936-945.
- Storebakken, T. (1988)** Krill as a potential feed source for salmonids. *Aquaculture* 70, 193-205.
- Storebakken, T. (2002)** Atlantic salmon, *Salmo salar*. In: Webster, C.M., Lim, C.E. (eds.). *Nutrient Requirements and Feeding of Finfish for Aquaculture*, CABI Publishing, Oxon, UK, pp. 79-102.
- Storebakken, T., Kvien, I.S., Shearer, K.D., Grisdale-Halland, B., Helland, S.J., Berge, G.M. (1998)** The apparent digestibility of diets containing fish meal, soybean meal or bacterial meal fed to Atlantic salmon (*Salmo salar*): evaluation of different faecal collection methods. *Aquaculture* 169, 195-210.
- Storebakken, T., Shearer, K.D., Roem, A.J. (1998)** Availability of protein, phosphorous and other elements in fish meal, soy-protein concentrate and phytase-treated soy-protein concentrate based diets to Atlantic salmon, *Salmo salar*. *Aquaculture* 161, 365-379.
- Storebakken, T., Refstie, S., Ruyter, B. (2000)** Soy products as fat and protein sources in fish feeds for intensive aquaculture. In: Drackley, J.K. (ed.). *Soy in Animal Nutrition*, Federation of Animal Science Societies, Savoy, IL, pp. 127-170.
- Storebakken, T., Shearer, K.D., Bæverfjord, G., Nielsen, B.G., Åsgård, T., Scott, T., De Laporte, A. (2000)** Digestibility of macronutrients, energy and amino acids, absorption of elements and absence of intestinal enteritis in Atlantic salmon, *Salmo salar*, fed diets with wheat gluten. *Aquaculture* 184, 115-132.

- Storelli, C., Verri, T. (1993)** Nutrient transport in fish: studies with membrane vesicles. In: Lahlou, B., Vitiello, P. (eds.) Aquaculture: fundamental and applied research. American Geophysical Union, Washington, DC, pp 139-157.
- Suárez, M.D., Hidalgo, M.C., Garcia-Gallego, M., de la Higuera, M. (1991)** Intermediary metabolism response of the European eel to dietary protein to lipids ratio. INRA (ed.) Fish Nutrition in Practice, Biarritz, France, pp. 327-331.
- Subasinghe, R., Soto, D., Jia, J. (2009)** Global aquaculture and its role in sustainable development. Reviews in Aquaculture 1, 2-9.
- Sugiura, S.H., Dong, F.M., Rathbone, C.K., Hardy, R.W. (1998)** Apparent protein digestibility and mineral availabilities in various feed ingredients for salmonid feeds. Aquaculture 159, 177-202.
- Sugiura, S.H., Babbitt, J.K., Dong, F.M., Hardy, R.W. (2000)** Utilization of fish and animal by-product meals in low-pollution feeds for rainbow trout *Oncorhynchus mykiss* (Walbaum). Aquac. Res. 31, 585–593.
- Sullivan, J.A., Reigh, R.C. (1995)** Apparent digestibility of selected feedstuffs in diets for hybrid striped bass (*Morone saxatilis* × *Morone chrysops*). Aquaculture 138, 313–322.
- Suzuki, E.Y., Early, R.J. (1991)** Analysis of chromic oxide in small samples of feeds and faeces using chlorine bleach. Canadian Journal of Animal Science 71, 931-934.
- Sveier, H. (2004)** The physical qualities and composition of dietary protein; effects on incorporation and growth in Atlantic salmon (*Salmo salar* L.). Ph.D. Thesis, University of Bergen, Bergen, Norway, 264 p.
- Tacon, A.G.J. (1987)** The nutrition and feeding of farmed fish and shrimp - A training manual. 2. nutrient sources and composition, GCP/RLA/075/I1A, FAO, Brasilia/Brazil.
- Tacon, A.G.J., Akiyama, D.M. (1997)** Feed ingredients, In: D'Abramo, L.R., Conklin, D.E., Akiyama, D.M. (Eds.), Crustacean Nutrition. Advances in World Aquaculture 6. World Aquaculture Society, Baton Rouge, LA, USA, pp. 411–472.
- Tacon, A.G.J., Metian, M. (2008)** Global overview on the use of fish meal and fish oil in industrially compounded aquafeeds: Trends and future prospects. Aquaculture 285, 146-158.
- Tacon, A.G.J., Metian, M. (2009)** Fishing for feed or fishing for food: increasing global competition for small pelagic forage fish. Ambio 38, 294-302.
- Tacon, A.G.J., Metian, M., Hasan, M.R. (2009)** Feed ingredients and fertilizers for farmed aquatic animals: sources and composition. FAO Fisheries and Aquaculture Technical Paper. No. 540. Rome, FAO. 2009. 209 p.
- Takeuchi, T., Yokoyama, M., Ogino, C. (1978)** Optimum ratio of dietary energy to protein for rainbow trout. Bull. Jpn Soc. Sci. Fish. 44, 729–732.
- Tarr, H.L.A., Biely, J. (1972)** Effect of processing on the nutritional value of fish meal and related products. In: Effect of Processing on the Nutritional Value of Feeds (ed. by National Academy of Sciences), pp. 252-281. National Academy of Sciences, Washington, DC, USA.
- Thiessen, D.L., Campbell, G.L., Adelizi, P.D. (2003)** Digestibility and growth performance of juvenile rainbow trout (*Oncorhynchus mykiss*) fed with pea and canola products. Aquaculture Nutrition 9, 67–75.



- Thiessen, D.L., Maenz, D.D., Newkirk, R.W., Classen, H.L., Drew, M.D. (2004)** Replacement of fishmeal by canola protein concentrate in diets fed to rainbow trout (*Oncorhynchus mykiss*). *Aquaculture Nutrition* 10, 379–388.
- Tibbetts, S.M., Lall, S.P., Milley, J.E. (2004)** Apparent digestibility of common feed ingredients by juvenile haddock, *Melanogrammus aeglefinus* L. *Aquac. Res.* 35, 643–651.
- Tibbetts, S.M., Milley, J.E., Lall, S.P. (2006)** Protein digestibility of common and alternative feed ingredients by juvenile Atlantic cod, *Gadus morhua*. XII International Symposium on Fish Nutrition and Feeding, 28 May– 1 June 2006, Biarritz, France, p. 245.
- Tibbetts, S.M., Milley, J.E., Lall, S.P. (2006)** Apparent protein and energy digestibility of common and alternative feed ingredients by Atlantic cod, *Gadus morhua* (Linnaeus, 1758). *Aquaculture* 261, 1314-1327.
- Tibbetts, S.M., Milley, J.E., Ross, N.W., Verreth, J.A.J., Lall, S.P. (2011)** *In vitro* pH-Stat protein hydrolysis of feed ingredients for Atlantic cod, *Gadus morhua*. 1. Development of the method. *Aquaculture* 319, 398-406.
- Toppe, J., Aksnes, A., Hope, B., Albrektsen, S. (2006)** Inclusion of fish bone and crab by-products in diets for Atlantic cod, *Gadus morhua*. *Aquaculture* 253, 636–645.
- Torrissen, O.J. (1995)** Strategies for salmonid pigmentation. *Journal of Applied Ichthyology* 11, 276-281.
- Treasurer, J.W., Sveier, H., Harvey, W., Allen, R., Cutts, C.J., Mazorra de Quero, C., Ford, L. (2006)** Growth, survival, diet and on-growing husbandry of haddock, *Melanogrammus aeglefinus* in tanks and netpens. *ICES Journal of Marine Science* 63, 376-384.
- Treasurer, J. (2008)** Haddock culture: Current knowledge and challenges. *Fish Farming Expert* 2, 62-65.
- Treimo, J., Aspmo, S.I., Eijsink, V.G.H., Horn, S.J. (2008)** Enzymatic solubilization of proteins in brewer's spent grain. *J. Agric. Food Chem.* 56, 5359-5365.
- Vandenberg, G.W., de la Noüe, J. (2001)** Apparent digestibility comparison in rainbow trout (*Oncorhynchus mykiss*) assessed using three methods of faeces collection and three digestibility markers. *Aquaculture Nutrition* 7, 237-245.
- Van den Ingh, T.S.G.A.M., Olli, J.J., Krogdahl, Å. (1996)** Alcohol-soluble components in soybeans cause morphological changes in the distal intestine of Atlantic salmon, *Salmo salar* L. *Journal of Fish Diseases* 19, 47-53.
- Van Lunen, T.A., Anderson, D.M. (1990)** Crab meal. In: *Non-traditional Feed Sources for Use in Swine Production* (ed. by P.A. Thacker and R.N. Kirkwood), pp. 153-159. Butterworths Publishers, Stoneham, MA, USA.
- Van Warde, A. (1983)** Aerobic and anaerobic ammonia production by fish. *Comp. Biochem. Physiol.* 74B, 675-684.
- Walker, A.B., Sidor, I.F., O'Keefe, T., Cremer, M., Berlinsky, D.L. (2010)** Partial replacement of fish meal with soy protein concentrate in diets of Atlantic cod. *North American Journal of Aquaculture* 72, 343-353.

- Watanabe, T. (2002)** Strategies for further development of aquatic feeds. *Fisheries Science* 68, 242-252.
- Wang, X., Parsons, C. (1997)** Effect of processing systems on protein quality of feather meal and hog hair meals. *Poult. Sci.* 76, 491-496.
- Watanabe, T., Takeuchi, T., Satoh, S., Kiron, V. (1996)** Digestible crude protein contents in various feedstuffs determined with four freshwater fish species. *Fish. Sci.* 62, 278–282.
- Watanabe, T., Takeuchi, T., Satoh, S., Kiron, V. (1996)** Digestible energy: methodological influences and a mode of calculation. *Fish. Sci.* 62, 288–292.
- Wei, Q., Zhimin, H., Deqing, S. (2003)** Product distribution of casein tryptic hydrolysis based on HPSEC analysis and molecular mechanism. *Chem. Eng. Sci.* 58, 767-775.
- Wei Q., Zhimin, H. (2006)** Enzymatic hydrolysis of protein: mechanism and kinetic model. *Front. Chem. China* 3, 308-314.
- Wendelaar-Bonga, S.E. (1993)** Endocrinology. In: Evans, D.H. (ed.) *The Physiology of Fishes*. CRC Press, Boca Raton, FL, pp. 469-502.
- Williams, C.M., Lee, C.G., Garlich, J.D., Shih, J.C.H. (1991)** Evaluation of a bacterial feather fermentation product, feather-lysate, as a feed protein. *Poult. Sci.* 70, 85-94.
- Wilson, R.P. (1994)** Utilization of dietary carbohydrates by fish. *Aquaculture* 124, 67–80.
- Wilson, R.P. (2002)** Amino acids and proteins. In: Halver, J.E., Hardy, R.W. (eds.) *Fish Nutrition*, 3rd Edition. Academic Press, New York, USA. pp. 143-179.
- Wilson, R.P., Poe, W.E. (1985)** Apparent digestible protein and energy coefficients of common feed ingredients for channel catfish. *Prog. Fish-Cult.* 47, 154–158.
- Woyewoda, A.D., Shaw, S.J., Ke, P.J., Burns, B.G. (1986)** Recommended laboratory methods for assessment of fish quality. *Canadian Tech Report of Fisheries and Aquatic Sciences*, vol. 1448ISSN :0706-6473. Fisheries and Oceans Canada.
- Xi, F., Wu, J., Jia, Z., Lin, X. (2005)** Preparation and characterization of trypsin immobilized on silica gel supported macroporous chitosan bead. *Process Biochem.* 40, 2833-2840.
- Yamamoto, T., Akiyama, T. (1995)** Effect of carboxymethylcellulose,  $\alpha$ -starch, and wheat gluten incorporated in diets as binders on growth, feed efficiency, and digestive enzyme activity of fingerling Japanese flounder. *Fish. Sci.* 61, 309–313.
- Yamamoto, T., Ikeda, K., Unuma, T., Akiyama, T. (1997)** Apparent availabilities of amino acids and minerals from several protein sources for fingerling rainbow trout. *Fish. Sci.* 63, 995–1001.
- Yamamoto, T., Akimoto, A., Kishi, S., Unuma, T., Akiyama, T. (1998)** Apparent and true availabilities of amino acids from several protein sources for fingerling rainbow trout, common carp, and red seabream. *Fisheries Science* 64, 448-458.
- Yu, P., McKinnon, J.J., Christensen, C.R., Christensen, D.A. (2004)** Using synchrotron-based FTIR microspectroscopy to reveal chemical features of feather protein secondary structure: comparison with other feed protein sources. *J. Agricult. Food Chem.* 52, 7353-7361.

**Zhu, C.F., Peng, H.B., Liu, G.Q., Zhang, F., Li, Y. (2010)** Beneficial effects of oligopeptides from marine salmon skin in a rat model of type 2 diabetes. *Nutrition* 26, 1014-1020.

# Appendices

## Summary

There is growing interest in gadoid farming as a means to meet the demand for Atlantic cod and haddock and to ease the strain on wild populations that would have otherwise been fished into extinction. Although the majority of farmed gadoid production will be accomplished through infrastructure that currently exists for marine salmonid farming, these feeds may not be suitable for gadoids due to differences in dietary protein digestion, absorption and metabolism as well as energy utilization. The primary research goals of this thesis were to: 1) examine the *in vivo* digestion and absorption of macronutrients from conventional or alternative (novel) feed ingredients incorporated into practical diets fed to juvenile gadoids (**Chapters 2 and 3**), 2) document the growth potential of gadoid fish at the juvenile grower phase given varying levels of dietary protein and energy (**Chapter 4**) and 3) to assess the potential of an *in vitro* pH-Stat method for rapid screening the protein quality of feed ingredients, specifically for gadoids (**Chapters 5 and 6**). All of these primary research questions were linked to, and built upon, one another with the ultimate goal of gaining a better understanding of protein and energy utilization of gadoids during the juvenile grower phase.

The studies presented in **Chapters 2 and 3** demonstrated that cod and haddock have a high capacity to utilize a wide range of dietary feed ingredients. High *in vivo* apparent protein digestibility (APD) was found for fish meals such as herring meal (93-96%) and anchovy meal (92%), whole freeze-dried krill meal (96%), soybean products such as soybean meal (92%), soy protein concentrate (99%) and soy protein isolate (97%) and wheat gluten meal (100%). Other feed ingredients having relatively high APD included corn gluten meal (86-92%), pea protein concentrate (90%), white lupin meal (90%), canola protein concentrate (89%) and crab meal (82-89%). High *in vivo* apparent energy digestibility (AED) was found for fish meals such as herring meal (92-93%) and anchovy meal (86%), whole freeze-dried krill meal (96%), soybean products such as soybean meal (88-92%), soy protein concentrate (95%) and soy protein isolate (92%) and wheat gluten meal (95%). Other feed ingredients having relatively high AED included crab meal (82-83%), corn gluten meal (81-83%) and canola protein concentrate (83%). The digestibility data presented in this thesis is currently the only research that has

examined both the *in vivo* (**Chapters 2 and 3**) and *in vitro* (**Chapter 6**) macronutrient digestibility of a large number and wide range of individual feed ingredients, specifically for gadoids. This data is essential to gain new knowledge on protein and energy utilization as well as for least-cost ration formulations and effective substitution of ingredients into new feed formulations.

Using species-specific *in vivo* protein and energy digestibility data from **Chapter 2** it was possible to precisely formulate several experimental diets for use in **Chapter 4** to further examine dietary protein and energy utilization of juvenile haddock with respect to growth rate, efficiency of protein and energy utilization and nutrient retention and deposition. The data presented in **Chapter 4** demonstrated that a dietary digestible protein/digestible energy (DP/DE) ratio of 30 g DP/MJ DE was required for haddock during the juvenile grower phase (<100 g). This DP/DE ratio was achieved in an experimental diet containing 54.8% crude protein, 11.4% lipid and 16.4% carbohydrate which agrees well with that of juvenile Atlantic cod. Fish fed this practical diet formulation had the highest daily growth rate (2.4%), lowest feed conversion ratio (0.7 g feed/g gain), highest protein and energy digestibility (94 and 86%, respectively), highest nitrogen gain (1.2 g/fish) and highest energy retention efficiency (46%). In addition, fish fed this diet had the lowest hepatosomatic index (9%) indicating that it prevented excessive liver lipid accumulation which has been problematic for farming of gadoids. This findings of this thesis have brought various preliminary nutrient requirement studies together for both cod and haddock and, through an applied nutritional approach using *in vivo* digestibility studies (**Chapters 2, 3 and 4**) and growth performance and nutrient utilization studies (**Chapter 4**), has identified that commercial feeds for juvenile gadoids (fingerling to 100 g) farmed in the Western North Atlantic should be formulated to contain 50-55% crude protein, <12% fat and <17% carbohydrate.

The studies presented in **Chapters 5 and 6** of this thesis are the first reports towards the development and application of an *in vitro* closed-system pH-Stat assay for rapid screening the protein quality of test feed ingredients that is 'species-specific' to gadoids. The method development studies (**Chapter 5**) demonstrated that by using a combination of techniques used previously with fish and shellfish, a species-specific protease enzyme cocktail rich in trypsin and chymotrypsin proteolytic activity (0.5 and

3.0 U/ $\mu$ g protein, respectively) could be produced relatively easily in the lab and had better frozen storage capacity. The studies demonstrated that the enzyme fractions had stable activity when stored at -80°C for up to 10 months while stability when stored at -20°C was lost after 8 months. These results provide very important quality-control information for subsequent studies presented in **Chapter 5** (optimum substrate concentration), studies presented in **Chapter 6** (*in vitro* pH-Stat degree of protein hydrolysis (DH) of feed ingredients) and also for future studies with respect to the thermal stability or usable “shelf-life” of enzyme fractions produced in the manner described in **Chapter 5** of this thesis. A major objective of **Chapter 5** was to determine the most appropriate protein substrate concentration [S] to use during pH-Stat assays. A [S] of 0.5 mg N/mL was found to be the most suitable based on the degree of protein hydrolysis (DH) curve progression having a rapid increase initially and then leveling off at maximum DH (26%) in a moderate assay duration (~6 hours) with minimal use of NaOH titrant (<12 mL) and this conclusion was also confirmed through slope modeling.

The final chapter of this thesis (**Chapter 6**) involved the application of the enzyme extraction methods and pH-Stat assay conditions from **Chapter 5** to measure the *in vitro* degree of protein hydrolysis (protein DH) of several conventional and novel feed ingredients by closed-system pH-Stat assay. The protein DH data were combined with *in vivo* apparent protein digestibility data (protein ADC) from **Chapter 3** to generate ‘species-specific’ equations to predict protein ADC. The equations resulted in good correlation (<4 percentage points difference) between ‘measured’ and ‘predicted’ protein ADC in the majority of cases ( $r = 0.90-0.99$ ;  $R^2 = 0.88-0.99$ ), while some ingredients were either over- or under-estimated (6-7 percentage points) which appears related to high ash or chitin content ( $r = 0.75$ ;  $R^2 = 0.61$ ) and may indicate the need for an acid pre-hydrolysis phase and full account of non-protein nitrogen (NPN) content. The ‘predicted’ *in vitro* protein ADC were high for wheat gluten meal (99%), soy protein concentrate (99%), soy protein isolate (98%) and whole krill meal (98%); relatively high for soybean meal (92%), white lupin meal (92%), herring meal (91%), anchovy meal (91%), canola protein concentrate (93%), pea protein concentrate (88%) and poultry by-product meal (87%); mid-range for crab meal (79%), shrimp meal (76%) and canola meal (75%); and low for hydrolyzed feather meal (62%) and flaxseed meal (56%). It was

concluded that the *in vitro* results (**Chapter 6**) generally reflected the results obtained through conventional *in vivo* protein digestibility methods (**Chapters 2 and 3**) and results were more rapidly obtained using less animals. The studies presented in **Chapters 5 and 6** have resulted in the first generation of a ‘gadoid-specific’ enzyme extraction method and *in vitro* closed-system pH-Stat assay, which will be useful to further investigate protein digestion, absorption and metabolism of gadoids and development of their feeds. The results of this thesis suggest good potential to reduce the use of high-cost fish meals in gadoid diets by replacement with other more economically cost-effective and more environmentally sustainable feed ingredients.



## Samenvatting

Er is groeiende belangstelling voor gadoid landbouw al seen middle om de vraag naar Atlantische kabeljauw en schelvis te ontmoeten en om de druk op wilde populaties die anders zou zijn geweest gevist in uitsterven te verlichten. Hoewel de meerderheid van gekweekte gadoid productie zal worden bereikt door de infrastructuur die momenteel bestaat voor de scheepvaart zalmachtigen landbouw, kunnen deze feeds niet geschikt voor gadoids te wijten aan verschillen in de eiwitbehoefte vertering, absorptie en metabolisme en energie gebruik. De voornaamste onderzoeksdoelstellingen van dit proefschrift waren: 1) onderzoekt de *in vivo* vertering en absorptie van macronutriënten van conventionele of alternatieve (nieuwe) diervoederingsrediënten opgenomen in praktische diëten gevoerd aan jeugdige gadoids (**hoofdstukken 2 en 3**), 2) het document van de groei van potentieel van gadoid vis op de juveniele fase teler krijgt verschillende niveaus van eiwitten en energie (**hoofdstuk 4**) en 3) de mogelijkheden van een *in vitro* pH-Stat methode voor snelle screening van het eiwit kwaliteit van de voedermiddelen te beoordelen, specifiek voor gadoids (**hoofdstuk 5 en 6**). Al deze primaire onderzoeksvragen zijn gekoppeld aan, en gebouwd op, een andere met het uiteindelijke doel van het verkrijgen van een beter begrip van eiwit-en energie-benutting van gadoids tijdens de jonge kweker fase.

De studies gepresenteerd in de **hoofdstukken 2 en 3** laten zien dat kabeljauw en schelvis een hoge capaciteit om een breed scala van dieet voedermiddelen te gebruiken zijn. Hoog *in vivo* zichtbaar eiwitverteerbaarheid (APD) werd gevonden voor vis eten, zoals haring eten (93 tot 96%) en ansjovis maaltijd (92%), hele gevriesdroogd krill meel (96%), soja-producten, zoals sojameel (92%), soja-eiwit concentraat (99%) en soja-eiwit isolaat (97%) en tarwe gluten maaltijd (100%). Andere voedermiddelen met relatief hoge APD opgenomen maïs glutenmeel (86-92%), erwten-eiwit concentraat (90%), witte lupine maaltijd (90%), canola-eiwit concentraat (89%) en krab maaltijd (82-89%). Hoog *in vivo* schijnbare energie verteerbaarheid (AED) werd gevonden voor vis eten, zoals haring eten (92 tot 93%) en ansjovis maaltijd (86%), hele gevriesdroogd krill meel (96%), soja-producten, zoals sojameel (88-92%), soja-eiwit concentraat (95%) en soja-eiwit isolaat (92%) en tarwe gluten maaltijd (95%). Andere voedermiddelen met relatief hoge AED

inbegrepen krab maaltijd (82-83%), maïsglutenmeel (81-83%) en canola-eiwit concentraat (83%). De verteerbaarheid data gepresenteerd in dit proefschrift is momenteel het enige onderzoek dat heeft onderzocht zowel de *in vivo* (**hoofdstukken 2 en 3**) en *in vitro* (**hoofdstuk 6**) macronutriënten verteerbaarheid van een groot aantal en een breed scala aan individuele diervoedingrediënten, specifiek voor gadoids. Deze data is essentieel om nieuwe kennis over eiwit-en energie-gebruik en voor least-cost rantsoen formuleringen en effectieve vervanging van de ingrediënten te krijgen in nieuwe feed formuleringen.

Met behulp van soortspecifieke *in vivo* eiwit-en energie verteerbaarheid van gegevens uit **hoofdstuk 2** was het mogelijk om precies te formuleren een aantal experimentele diëten voor gebruik in **hoofdstuk 4** tot en met eiwitten en energie het gebruik van jonge schelvis verder te onderzoeken met betrekking tot de groei, efficiëntie van de eiwit-en energie- gebruik en voedingsstoffen vasthouden en depositie. De gegevens gepresenteerd in **hoofdstuk 4** aangetoond dat een voeding verteerbare eiwitten / verteerbare energie (DP/DE) verhouding van 30 g DP/MJ DE nodig was voor schelvis in de juveniele teler fase (<100 g). Deze DP/DE verhouding werd bereikt in een experimentele dieet met 54.8% ruw eiwit, 11.4% vet en 16.4% koolhydraten die goed overeenstemmen met die van jonge kabeljauw. Vissen gevoed deze praktische dieet formulering had de hoogste dagelijkse groei (2.4%), laagste voederconversie ratio (0.7 g voeder/g gain), de hoogste eiwit en energie verteerbaarheid (94 en 86%, respectievelijk), hoogste stikstof te krijgen (1.2 g/vis) en de hoogste energie-efficiëntie retentie (46%). Daarnaast, vissen gevoed dit dieet had de laagste hepatosomatic index (9%) die aangeeft dat het overdreven lever vet ophoping die problematisch waren voor de landbouw van gadoids voorkomen. Deze bevindingen van dit proefschrift hebben geleid tot diverse voorbereidende voedingsstoffen vereiste studies samen voor zowel de kabeljauw en schelvis en, door middel van een toegepaste voedings-benadering met behulp van *in vivo* verteerbaarheid studies (**hoofdstukken 2, 3 en 4**) en de groei prestaties en nutriëntenbenutting studies (**hoofdstuk 4**), heeft vastgesteld dat de commerciële feeds voor jeugdige gadoids (fingerling tot 100 g), gekweekt in de West-Noord-Atlantische Oceaan moet worden geformuleerd om 50-55% ruw eiwit, <12% vet en <17% koolhydraten bevatten.

De studies gepresenteerd in **hoofdstuk 5 en 6** van dit proefschrift zijn de eerste berichten naar de ontwikkeling en toepassing van een *in vitro* gesloten systeem pH-Stat test voor een snelle screening van het eiwit kwaliteit van test diervoedingrediënten dat is 'soort eigen' om gadoïds. De methode ontwikkeling studies (**hoofdstuk 5**) toonde aan dat met behulp van een combinatie van technieken eerder gebruikte met vis en schaaldieren, een soort-specifiek protease-enzym cocktail rijk aan trypsine en chymotrypsine proteolytische activiteit (0.5 en 3.0 U/ $\mu$ g eiwit, respectievelijk) kan worden relatief gemakkelijk geproduceerd in het lab en maar beter bevroren opslagcapaciteit. De studies hebben aangetoond dat het enzym fracties stabiele activiteit was indien bewaard bij  $-80^{\circ}\text{C}$  tot 10 maanden, terwijl de stabiliteit indien bewaard bij  $-20^{\circ}\text{C}$  werd verloren na 8 maanden. Deze resultaten leveren een zeer belangrijke kwaliteitscontrole van informatie voor latere studies gepresenteerd in **hoofdstuk 5** (optimale substraat concentratie), studies gepresenteerd in **hoofdstuk 6** (*in vitro* pH-Stat mate van eiwithydrolyse (DH) van diervoedingrediënten) en ook voor toekomstige studies met betrekking tot de thermische stabiliteit of bruikbare "shelf-life" van enzym fracties geproduceerd op de wijze zoals beschreven in **hoofdstuk 5** van dit proefschrift. Een belangrijke doelstelling van **hoofdstuk 5** was om de meest geschikte eiwit substraat concentratie [S] te gebruiken tijdens de pH-Stat testen te bepalen. A [S] van 0.5 mg N/mL was gevonden om de meest geschikte gebaseerd op de mate van eiwithydrolyse (DH) curve progressie met een snelle stijging in eerste instantie en daarna afvlakt bij maximale DH (26%) in een matige test duur worden (~ 6 uur) met minimaal gebruik van NaOH titrant (<12 ml) en deze conclusie werd ook bevestigd door de helling modellering.

Het laatste hoofdstuk van dit proefschrift (**hoofdstuk 6**) die betrokken zijn op de toepassing van het enzym extractiemethoden en pH-Stat assay voorwaarden uit **hoofdstuk 5** van de *in vitro* mate van eiwithydrolyse (eiwit DH) van diverse conventionele en nieuwe diervoedingrediënten te meten door closed-systeem pH-Stat assay. Het eiwit DH gegevens werden gecombineerd met *in vivo* schijnbaar eiwitverteerbaarheid data (eiwit ADC) van **hoofdstuk 3** tot en met 'soortspecifieke' vergelijkingen te genereren van eiwit ADC voorspellen. De vergelijkingen resulteerde in een goede correlatie (<4 procentpunten verschil) tussen 'gemeten' en 'voorspelde' eiwit

ADC in de meeste gevallen ( $r = 0.90-0.99$ ;  $R^2 = 0.88$  tot  $0.99$ ), terwijl sommige ingrediënten waren ofwel over-of onder-schatting (6-7 procentpunten) die is opgenomen met betrekking tot hoge as of chitine inhoud ( $r = 0.75$ ;  $R^2 = 0.61$ ) en kan de noodzaak van een zure hydrolyse pre-fase en volle rekening gehouden met niet-eiwit stikstof (NPN geven) content. De 'voorspelde' *in vitro* proteïne ADC waren hoog voor tarwe gluten eten (99%), soja-eiwit concentraat (99%), soja-eiwit isolaat (98%) en hele krill meel (98%), relatief hoog voor sojameel (92 %), witte lupine maaltijd (92%), haring eten (91%), ansjovis maaltijd (91%), canola-eiwit concentraat (93%), erwten-eiwit concentraat (88%) en pluimvee bijproduct maaltijd (87%), mid-range voor de krab maaltijd (79%), garnalen maaltijd (76%) en canola maaltijd (75%) en laag voor gehydrolyseerd verenmeel (62%) en lijnzaad maaltijd (56%). Er werd geconcludeerd dat de *in vitro* resultaten (**hoofdstuk 6**) in het algemeen de resultaten verkregen door middel van conventionele *in vivo* eiwitverteerbaarheid methodes (**de hoofdstukken 2 en 3**) en de resultaten waren sneller verkregen met behulp van minder dieren weerspiegeld. De studies gepresenteerd in **hoofdstuk 5 en 6** hebben geleid tot de eerste generatie van een 'gadoid-specifieke' enzym extractie methode en *in vitro* gesloten systeem pH-Stat test, die nuttig zal zijn om verder te onderzoeken eiwit vertering, absorptie en metabolisme van gadoids en de ontwikkeling van hun feeds. De resultaten van dit proefschrift suggereren goede mogelijkheden voor het gebruik van hoge kosten vis gerechten te verminderen gadoid diëten door vervanging door andere, meer economisch rendabel en ecologisch duurzame voedingsingrediënten.

## List of publications

### Peer-reviewed journal papers

**Tibbetts, S.M.**, Milley, J.E., Lall, S.P. Composition, total phenolics content and *in vitro* protein digestibility of microalgae cultured in photobioreactors. Food Chemistry (Manuscript in progress).

Colombo-Hixson, S.M., Olsen, R.E., **Tibbetts, S.M.**, Lall, S.P. (2011) Evaluation of *Calanus* copepod and *Euphausia* krill meal as dietary protein and lipid supplements for juvenile Atlantic halibut (*Hippoglossus hippoglossus*). Aquaculture (Submitted manuscript).

**Tibbetts, S.M.**, Milley, J.E., Ross, N.W., Verreth, J.A.J., Lall, S.P. (2011) *In vitro* pH-Stat protein hydrolysis of feed ingredients for Atlantic cod, *Gadus morhua*. 1. Development of the method. Aquaculture 319, 398-406.

**Tibbetts, S.M.**, Verreth, J.A.J., Lall, S.P. (2011) *In vitro* pH-Stat protein hydrolysis of feed ingredients for Atlantic cod, *Gadus morhua*. 2. *In vitro* protein digestibility of common and alternative feed ingredients. Aquaculture 319, 407-416.

**Tibbetts, S.M.**, Olsen, R.E., Lall, S.P. (2011) Effects of partial or total replacement of fish meal with freeze-dried krill (*Euphausia superba*) on growth and nutrient utilization of juvenile Atlantic cod (*Gadus morhua*) and Atlantic halibut (*Hippoglossus hippoglossus*) fed the same practical diets. Aquaculture Nutrition 17, 287-303.

Lall, S.P., **Tibbetts, S.M.** (2009) Nutrition, feeding, and behaviour of fish. In: Hess, L., Antinoff, N. (Eds.), Nutrition and Behaviour of Uncommon Species, Vet. Clin. N. Amer. – Exot. Anim. Pract. 12, 361-372.

Kim, J-D., **Tibbetts, S.M.**, Milley, J.E., Lall, S.P. (2007) Effect of the incorporation level of dehulled soybean meal into test diet on apparent digestibility coefficients for protein and energy by juvenile haddock, *Melanogrammus aeglefinus* L. Aquaculture 267, 308-314.

**Tibbetts, S.M.**, Milley, J.E., Lall, S.P. (2006) Apparent protein and energy digestibility of common and alternative feed ingredients by Atlantic cod, *Gadus morhua* (Linnaeus, 1758). Aquaculture 261, 1314-1327.

Kim, J-D., **Tibbetts, S.M.**, Milley, J.E., Lall, S.P. (2006) Effect of the incorporation level of herring meal into test diet on apparent digestibility coefficients for protein and energy by juvenile haddock, *Melanogrammus aeglefinus* L. Aquaculture 258, 479-486.

**Tibbetts, S.M.**, Lall, S.P., Milley, J.E. (2005) Effects of dietary protein and lipid levels and DP/DE ratio on growth, feed utilization and hepatosomatic index of juvenile haddock, *Melanogrammus aeglefinus* L., *Aquaculture Nutrition* 11, 67-75.

**Tibbetts, S.M.**, Lall, S.P., Milley, J.E. (2004) Apparent digestibility of common feed ingredients by juvenile haddock, *Melanogrammus aeglefinus* L. *Aquaculture Research* 35, 643-651.

**Tibbetts, S.M.** (2003) Diet and feeding of eels for aquaculture. *Hatchery International* 4, 22-23.

Lall, S.P., Nanton, D.A., **Tibbetts, S.M.**, Roy, P.K., Milley, J.E. (2003) Nutrient requirements and feeding of haddock. In: *Early Rearing of Haddock: State of the Art* (ed. by D.E. Aiken), pp. 79-86. Bulletin of the Aquaculture Association of Canada, Special Publication Number 7.

**Tibbetts, S.M.**, Lall, S.P., Anderson, D.M. (2001) Optimum dietary ratio of digestible protein and energy for juvenile American eel, *Anguilla rostrata*, fed practical diets. *Aquaculture Nutrition* 7, 213-220.

**Tibbetts, S.M.**, Lall, S.P., Anderson, D.M. (2000) Dietary protein requirement of juvenile American eel (*Anguilla rostrata*) fed practical diets. *Aquaculture* 186, 145-155.

### **Short papers and conference abstracts**

**Tibbetts, S.M.**, Milley, J.E., Lall, S.P. (2011) *In vitro* protein quality evaluation of seaweeds and microalgae. 4<sup>th</sup> Congress of the International Society for Applied Phycology, 19-24 June 2011, Halifax, Nova Scotia, Canada, p. 104.

**Tibbetts, S.M.**, Milley, J.E., Ross, N.W., Lall, S.P. (2010) Development of a pH-Stat method to measure *in vitro* degree of protein hydrolysis using enzymes from pyloric caeca of Atlantic cod (*Gadus morhua* L.). XIV International Symposium on Fish Nutrition and Feeding, 31 May - 4 June 2010, Qingdao, China, p. 14.

**Tibbetts, S.M.**, Walbourne, C.M., Hori, T.S.F., Afonso, L.O.B., Lall, S.P. (2008) Effects of dietary cholesterol history on stress response of juvenile Atlantic cod, *Gadus morhua* L. XIII International Symposium on Fish Nutrition and Feeding, 1-5 June 2008, Florianópolis, Brazil, p. 70.

Kim, J-D., Lall, S.P., **Tibbetts, S.M.**, Milley, J.E. (2006) Effect of the incorporation level of soybean meal into reference diet on apparent digestibility coefficients for protein and energy by juvenile haddock, *Melanogrammus aeglefinus* L. XII International Symposium on Fish Nutrition and Feeding, 28 May - 1 June 2006, Biarritz, France, p. 244.

**Tibbetts, S.M.**, Milley, J.E., Lall, S.P. (2006) Protein digestibility of common and alternative feed ingredients by juvenile Atlantic cod, *Gadus morhua*. XII International Symposium on Fish Nutrition and Feeding, 28 May - 1 June 2006, Biarritz, France, p. 245.

**Tibbetts, S.M.** , Lall, S.P. (2006) Utilization of plant protein sources by juvenile Atlantic cod (*Gadus morhua* L.). Aquaculture Canada 2006, 23<sup>rd</sup> Annual Meeting of the Aquaculture Association of Canada, November 19-22, 2006, Halifax, Nova Scotia, Canada, p. 57.

Kim, J-D., Lall, S.P., **Tibbetts, S.M.** (2005) Effect of dietary levels of herring meal on apparent protein digestibility by juvenile haddock, *Melanogrammus aeglefinus* L. Aquaculture Association of Canada Special Publication 9, 88-90.

Kim, J-D., Lall, S.P., **Tibbetts, S.M.** (2004) Digestibility assay for haddock, *Melanogrammus aeglefinus* L.: Effect of varying levels of fishmeal in the diet on apparent protein and energy digestibility. Aquaculture Canada 2004, 21<sup>st</sup> Annual Meeting of the Aquaculture Association of Canada, October 17-20, 2004, Quebec City, Quebec, Canada.

Doncaster, K.L., Lall, S.P., **Tibbetts, S.M.**, Milley, J.E. (2003) Alternate dietary lipid sources in juvenile haddock diets: effects on growth, feed efficiency, digestibility and muscle fatty acid composition. 13<sup>th</sup> Annual Atlantic Universities Aquaculture Conference, March 7-9, 2003, Halifax, Nova Scotia, Canada.

**Tibbetts, S.M.** (2003) Fish feeds and feed technology. Finfish Nutrition Course, Education Series Co-sponsored by the Canadian Aquaculture Institute and AquaNet, March 24-25, 2003, Moncton, New Brunswick, Canada.

Doncaster, K.L., Lall, S.P., **Tibbetts, S.M.**, Milley, J.E. (2002) Effect of replacing marine fish oil with plant oils and poultry fat on growth and tissue lipid composition of juvenile haddock (*Melanogrammus*

*aeglefinus* L.). AquaNet II, Annual Research Conference and Annual General Meeting of AquaNet, September 14-17, 2002, Moncton, New Brunswick, Canada.

Doncaster, K.L., Lall, S.P., **Tibbetts, S.M.**, Milley, J.E. (2002) Effect of replacing marine fish oil with plant oils and poultry fat on growth and tissue lipid composition of juvenile haddock (*Melanogrammus aeglefinus* L.). Aquaculture Canada 2002, 19<sup>th</sup> Annual Meeting of the Aquaculture Association of Canada, September 17-20, 2002, Charlottetown, Prince Edward Island, Canada.

**Tibbetts, S.M.**, Lall, S.P., Milley J.E. (2002) *In vivo* and *in vitro* protein digestibility of common feed ingredients by haddock, *Melanogrammus aeglefinus*, and Atlantic halibut, *Hippoglossus hippoglossus*. Aquaculture Canada 2002, 19<sup>th</sup> Annual Meeting of the Aquaculture Association of Canada, September 17-20, 2002, Charlottetown, Prince Edward Island, Canada.

**Tibbetts, S.M.**, Lall, S.P., Milley J.E. (2001) Effect of dietary protein/energy ratio on growth, nutrient utilization and hepatosomatic index of juvenile haddock, *Melanogrammus aeglefinus*. Aquaculture Canada 2001, 18<sup>th</sup> Annual Meeting of the Aquaculture Association of Canada, May 6-9, 2001, Halifax, Nova Scotia, Canada.

**Tibbetts, S.M.** (2001) Biology, markets and culture of *Anguillid* eels. Hook, Line and Thinker: The Newsletter of the Fishermen and Scientists Research Society. FSRS 2001-4, 10-13.

**Tibbetts, S.M.**, Lall, S.P., Milley J.E. (2000) Utilization of major dietary nutrients by juvenile haddock (*Melanogrammus aeglefinus*). Aquaculture Canada 2000, 17<sup>th</sup> Annual Meeting of the Aquaculture Association of Canada, May 29-June 1, 2000, Moncton, New Brunswick, Canada.

Bricelj, V.M., **Tibbetts, S.M.**, McKenna, S. (2000) Biological and economic feasibility of land-based overwintering of European oyster, *Ostrea edulis*, seed. Aquaculture Canada 2000, 17<sup>th</sup> Annual Meeting of the Aquaculture Association of Canada, May 29-June 1, 2000, Moncton, New Brunswick, Canada.

**Tibbetts, S.M.**, Lall, S.P., Anderson, D.M. (1998) Optimum protein level in a practical fish-meal based diet for American eel (*Anguilla rostrata*). Aquaculture Canada 1998, 15<sup>th</sup> Annual Meeting of the Aquaculture Association of Canada, May 31-June 3, 1998, St. John's, Newfoundland, Canada.



**Tibbetts, S.M.**, Lall, S.P., Anderson, D.M., Peterson, R.H. (1998) Nutritional development for juvenile American eel (*Anguilla rostrata*): Optimum dietary protein requirement. 8<sup>th</sup> Annual Atlantic Universities Aquaculture Conference, March 6-8, 1998, Halifax, Nova Scotia, Canada.

**Tibbetts, S.M.**, Lall, S.P., Anderson, D.M., Peterson, R.H. (1998) Optimum dietary protein requirement for juvenile American eel (*Anguilla rostrata*). Aquaculture '98, The International Triennial Conference and Exposition of the World Aquaculture Society, National Shellfisheries Association and American Fisheries Society Fish Culture Section, February 15-19, 1998, Las Vegas, Nevada, USA.

**Tibbetts, S.M.**, Lall, S.P., Anderson, D.M. (1998) Optimum protein level in a practical fishmeal-based diet for juvenile American eel (*Anguilla rostrata*). Bulletin of the Aquaculture Association of Canada 98-2, 50-52.

**Tibbetts, S.M.**, Lall, S.P., Anderson, D.M. (1997) Feed enhancement and diet development for juvenile stage American eel (*Anguilla rostrata*). 7<sup>th</sup> Annual Atlantic Universities Aquaculture Conference, March 7-9, 1997, Truro, Nova Scotia, Canada.

Webster, A.B., **Tibbetts, S.M.**, Mullins, T.F., Crober, D.C. (1994). Effect of dissolved iodine in drinking water on the production performance of broiler chickens. 3<sup>rd</sup> Annual Atlantic Canada Animal Science and Technology Workshop, May 17-19, 1994, Truro, Nova Scotia, Canada.

**Tibbetts, S.M.**, Lall, S.P., Anderson, D.M. (1993) Digestibility measurements of various alternate feedstuffs for Atlantic salmon (*Salmo salar*). 2<sup>nd</sup> Annual Atlantic Canada Animal Science and Technology Workshop, May 26-28, 1993, Truro, Nova Scotia, Canada.

## About the author

Sean Michael Tibbetts was born on 21<sup>st</sup> of September, 1970 in Halifax, Nova Scotia, Canada as the second child of Kenneth Graham Tibbetts and Jean Kathleen Tibbetts (nee McKim). He obtained his first degree in 1994, a BSc (Agr.) in Animal Science (Honours) from Dalhousie University (Halifax, Nova Scotia) in association with the Nova Scotia Agricultural College (Truro, Nova Scotia). He then worked as a Research Assistant with the Atlantic Poultry Research Institute, (Truro, Nova Scotia) in the areas of poultry nutrition, welfare and behaviour. In 1995, he enrolled at Dalhousie University and the Nova Scotia Agricultural College and was granted his second degree in 1999, an MSc (Agr.) in Monogastric Animal Nutrition. He immediately started working as a Nutrition Research Technologist at the National Research Council of Canada – Institute for Marine Biosciences (NRCC-IMB) in Halifax, Nova Scotia and has worked in the areas of shellfish and marine finfish aquaculture, feed production technology, basic and applied fish, animal and human nutrition, marine bioactives and algal biofuels. During this time, he published 11 peer-reviewed journal papers and numerous proceedings papers and conference abstracts. In addition, he has been invited to do peer-review for *Journal of the World Aquaculture Society*, *Journal of Fish Biology*, *Aquaculture*, *Aquaculture Research*, *New Zealand Journal of Marine and Freshwater Research*, *North American Journal of Aquaculture* and *Journal of Agricultural Science and Technology*. In 2008, he began his third degree, a PhD in Aquatic Animal Nutrition with the Aquaculture and Fisheries Group, Wageningen Institute of Animal Sciences at Wageningen University, The Netherlands. After completion of his PhD, he will continue his work at the NRCC-IMB in Halifax, Nova Scotia, Canada.

This work was supported primarily by the National Research Council of Canada - Institute for Marine Biosciences (Halifax, Nova Scotia) with additional funding from Heritage Aquaculture Limited (St. George, New Brunswick) and the National Resesearch Council of Canada - Industrial Research Assistance Program (Halifax, Nova Scotia).

## Acknowledgements

This thesis would never have been completed without tremendous contributions of many talented and dedicated colleagues, professors, lab-mates, instructors and friends; I thank-you all for assistance in the laboratory, advice and encouragement and, above all, your friendship.

I particularly want to thank two very important people. Thank-you Dr. Neil Ross for being so generous with your time as I was struggling to understand the principles of applied biochemistry and enzyme kinetics. I have been very fortunate to benefit from your contagious enthusiasm, friendship and your wonderful support especially during difficult times within and outside of the lab. I extend my deepest gratitude to Joyce Milley for countless hours of teaching and assistance with laboratory analyses, tissue sampling and data collection, consultation on lab procedures and results and scientific writing. You have pushed me to a level that I thought I was not capable of achieving; you are a great analytical chemist and a superb teacher. You have increased the quality of all of this work; none of which would have been possible without you. I am proud to call you a colleague and a friend.

I am grateful to my thesis promoters Dr. Santosh P. Lall (Canada) and Dr. Johan A.J. Verreth (The Netherlands) and my co-promoter Dr. Johan W. Schrama (The Netherlands) for supporting me as an external PhD candidate. Allowing me to pursue my Doctorate in this manner has permitted me to maintain precious time with my wife and young family and has allowed us to maintain our careers with little interruption and for this, I am truly grateful. To Santosh, my mentor of almost 2 decades, you are a great example of how to achieve success as a research scientist and maintain high respect of your peers and still be one of the most humble, selfless and kindest humans I have known.

I gratefully acknowledge the support of my oldest and dearest friends, Jeff Lipton, Jason Young, Steven Irsa and Glen Farrell. Thank-you for a 'lifetime' of cherished memories. Thank-you for your individual strengths that I persistently struggle to mirror. Most important, thank-you for your humor and for your friendship throughout the many chapters of our lives. Friends, girlfriends, school, careers, family and other life

commitments have come and gone and geography has separated us, but you guys remain ‘rocks’ that ground me and our friendship has shaped who I am today.

I thank my parents Kenneth and Jean (nee McKim) Tibbetts for your enduring love and support of my various endeavors. Thank-you Mom for being a wonderful ‘pillar of strength and wisdom’ and for your words of encouragement whenever I needed them; and so often still do. Thank-you Dad for passing onto me your love of science and nature and ‘all things fishy’; I became a part of biological science because of your passions and the experiences we shared. I gratefully acknowledge my sister Laura Tibbetts-Napke for always being there for me with support, much-needed big-sister advice and for being such a tremendous ‘positive spirit’ in my life. I am grateful to my in-law family Bill and Sandy (nee Reid) Scott, Margaret Reid and Stacey Scott and Jonathan Histon. Thank-you for welcoming me into your family, for always supporting my marriage to Shannon, and for your love and support of Evyn and Liam.

I also thank all those who graciously reviewed portions of this thesis and provided valuable input and comments from different scientific and non-scientific backgrounds.

Most importantly, I thank my wife Shannon. I could never have completed this endeavor without your patience, love, support, strength and understanding. There were many late nights and early mornings where writing this thesis became my mistress and you never criticized; but only encouraged. You made this achievement possible in so many ways and I am eternally grateful for your unconditional love, strength and support.

Cover designed by Sean Tibbetts and Laura Garrison

Printed by: CPI Koninklijke Wöhrmann, The Netherlands