

Working Paper Series
ISSN 1177-777X

**TRACKING BATTERY
STATE-OF-CHARGE IN A
CONTINUOUS USE OFF-GRID
ELECTRICITY SYSTEM**

M. D. Apperley and M. M. Alahmari

Working Paper: 04/2013
October 2013

© 2013 M. D. Apperley and M. M. Alahmari
Department of Computer Science
The University of Waikato
Private Bag 3105
Hamilton, New Zealand

Tracking Battery State-of-Charge in a Continuous Use Off-Grid Electricity System

M. D. Apperley and M. M. Alahmari

University of Waikato, Hamilton, New Zealand
m.apperley@waikato.ac.nz

Abstract. The growing importance of batteries in the delivery of primary energy, for example in electric vehicles and isolated off-grid electricity systems, has added weight to the demand for simple and reliable measures of a battery’s remaining stored energy at any time. Many approaches to estimating this battery state-of-charge exist, ranging from those based on a full appreciation of the chemistry and physics of the storage and delivery mechanisms used, and requiring extensive data on which to base an estimate, to the naïve and simple, based only, for example, on the terminal voltage of the battery. None, however, is perfect, and able to deliver a simple percentage-full figure, as in a fuel gauge. The shortcomings are due to a range of complicating factors, including the impact of rate of charge, rate of discharge, battery aging, and temperature, to name just some of these.

This paper presents a simple yet effective method for tracking state-of-charge in an off-grid electricity system, where batteries are in continuous use, preventing static parameter measurements, and where charge/discharge cycles do not necessarily follow an orderly sequence or pattern. A reliable indication of state-of-charge is, however, highly desirable, but need be only of fuel gauge precision, say to the nearest 12-20%. The algorithm described utilises knowledge of the past, and constantly adapts parameters such as charge efficiency and total charge capacity based on this knowledge, and on the occurrence of specific identifiable events such as zero or full charge.

Keywords: state-of-charge · battery · time series data · lead-acid · off-grid

1 Introduction

A confident estimate of the state of charge (SoC) of lead-acid batteries is highly desirable, yet often elusive. The increasing use of such batteries as a primary energy supply, in particular in electric vehicles, but also in off-grid electricity systems, has heightened awareness of this situation. A range of techniques exist for predicting the energy stored (see, for example [1, 2, 3]). Many of these take full account of a detailed knowledge of the chemistry and physics involved in energy storage and retrieval, but are dependent on multiple parameters, such as voltage, impedance, charge/discharge rates, open circuit voltage, and temperature, some of which can be measured effectively only when the battery is at rest. As Scott et al [3] have commented, “While these methods are powerful they require significant training, and the training data must include the output variable—the remaining capacity—that is typically only available as an estimate with hindsight.”

Yet this information is important. For the driver of an electric vehicle, it is imperative to be able to answer such questions as “Do I have enough charge in the battery to get me home?” or “Do I need to re-charge the battery overnight so I can drive to work tomorrow?” For the person living in an off-grid dwelling, there are similar questions: “Is there enough charge in the batteries for me to use the electric saw to cut firewood?” or “Was it sunny enough today to fully charge the batteries, or do we need to start the back-up generator now to provide enough energy to last us through the night?” But to answer questions like these we do not need to know the precise residual charge in the batteries, even if it was possible to calculate, but rather, we need an estimate, something like the fuel gauge in a car (see Figure 1), to say the nearest 12.5%.

Typically, the basic battery status information available for an off-grid power installation is a volt-meter, similar to that shown in Figure 2. While this example meter does include *green* (OK) and *red* (problem) bands, and indicates ranges for *low battery* and *on charge*, the pointer could be in the *low battery* range with a fully charged battery under heavy load, and a battery that is almost completely discharged will show a voltage well into the green band as soon as charging commences. Voltage alone is not a reliable indicator of state of charge unless the battery is at rest, a situation rarely experienced in an off-grid system. In fact, this never-at-rest phenomenon makes the off-grid state-of-charge estimation

more difficult than that for an electric vehicle, where the battery will normally have been at rest for a period prior to each use of the vehicle.



Figure 1: The example of a car fuel gauge, which gives a rough indication of the fuel remaining, sufficient for most purposes.

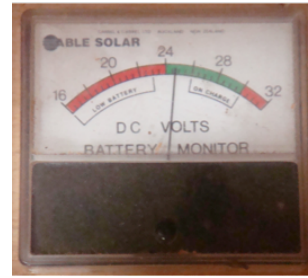

Figure 2: A typical off-grid installation battery voltage meter.

If a full history of past charging and discharging of a battery is available, then it is possible to base a state-of-charge estimate on this history, using the so-called “ampere hour counting” or “Coulomb counting” method to maintain a total charge figure [1], [4]. With this approach, it is possible to account for losses in the battery using a charge-efficiency factor, which can be experimentally determined. However, there are a variety of other factors which such a “black-box” approach overlooks, and consequently significant drift errors can accumulate over time, rendering the calculated state-of-charge grossly in error. An approach to minimising such drift is to recalibrate the calculations whenever possible using known events. Typically such events are indications of either full-charge, or full discharge, often flagged by other components in the battery system. If a battery is regularly charged until it is “full”, as is often the case, for example, with an electric vehicle, then when the charging system indicates this *full* state, the **SoC** calculation can be recalibrated at this point. Less common, but still occurring, are *battery empty* events, typically triggered by auto-protect systems which shut off the load when the battery charge level is observed to be so low that further discharging may cause long-term damage to the battery. These are referred to as low-voltage shut-down events (LVSDs).

However, there are a number of confounding factors that arise with the potentially continuous use nature of batteries in an off-grid installation, which add to the challenge of determining an accurate estimation of state-of-charge.

1.1 While there are system events that might be used to flag 0% and 100% battery charge as indicated above, these events, which are triggered by other sensing hardware that forms part of the off-grid installation, are neither fundamental nor deterministic, and there may sometimes be conflict between different components. Section 2 describes a typical off-grid installation (the one from which the data used in this study was derived) which includes separate solar controller and inverter/charger modules, each of which independently senses and interprets the battery state for its own purpose.

- a) The inverter/charger in the installation shuts down if the battery voltage falls below 23.2 volts for more than 2 minutes [5]. While this is a proxy for 0% charge level, it can occur well above 0% **SoC** during the application of a heavy load.
- b) The solar controller in the installation, and the inverter/charger, both (independently) switch to absorption charging mode [5, 6, 7] when the battery is nearing full charge, indicated by a particular combination of voltage and current. However, each module assumes that there is no other current demand on the battery, so in normal operation both can give false indications (see Figure 3). The inverter/charger will have a false impression of the actual battery current if there is also input from the solar controller, as will the solar controller if the inverter is applying a load to the batteries, which is commonly the case.

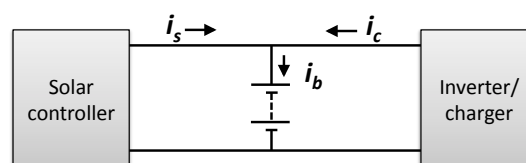

Figure 3: Neither the inverter/charger nor the solar controller can independently determine the actual battery current, i_b .

- c) Battery voltage under charge is dependent on charge rate, and a high charge rate can give rise to a false impression of 100% SoC at a significantly lower charge level [8,9].
- 1.2 Battery characteristics are not constant, with changes arising for a number of reasons [8]:
- a) As a battery ages, its full charge capacity will decrease.
 - b) Temperature is a factor in battery behaviour, and many complex battery monitors do incorporate temperature sensors.
 - c) Charging behaviour changes with charging current. A fast charge rate may appear to have fully charged a battery (from voltage/current behaviour) well before 100% charge is achieved; a lower charge rate may ultimately deliver a fuller charge [10].
 - d) Discharging behaviour varies with load. Under a high current load, battery voltage will drop, and not just because of internal resistance. It will also take time to recover voltage after the load is removed.
 - e) Left unattended and unused for a period of time, lead-acid batteries do self-discharge, continuously losing a small proportion of their charge [4].
- 1.3 Not all of the energy delivered to a battery during a charge cycle is stored. Some of it is released as heat. Although this lost energy can be accounted for by an overall *charge efficiency*, this is typically not constant, and varies with temperature, charge rate, and SoC [4], [8], [11].
- 1.4 Batteries in an off-grid installation do not undergo a regular or cyclic full charge/discharge sequence. For example, with a PV array, if sunshine coincides with a high load, then the potential solar charge is delivered directly to the load, and not to the batteries. If wind generation is included, then this is generally non-deterministic, and not cyclic. During any 24-hour interval, there may be several periods in which the batteries are charging from one source or another, at varying rates of charge, depending on the source and any loads present at the time, and these may not always culminate in a full charge [4].

The challenge addressed in this paper is to develop a time series-based [12] algorithm (B3SOC – **Black Box Battery State Of Charge**) that will reliably provide an estimate of the state-of-charge of the batteries in an off-grid electricity installation, where the system is in continuous use. Section 2 describes the characteristics and technical details of a typical off-grid system, and identifies the parameters that might be used by such an algorithm. In Section 3, detailed data derived from this system is examined and analysed, and an algorithm developed which has the potential to calculate SoC to an appropriate accuracy. The application of the algorithm to a three-week data set is then described in Section 4, with an equivalent real-time state-of-charge calculated. The effectiveness of the approach in delivering a solution to the challenge is reviewed in Section 5.

2 Overview of the Off-Grid System

A representative off-grid electricity system is shown in Figure 4. This diagram describes the off-grid installation at Pauaeke, which has been used to provide the data analysed in this paper. Pauaeke, which is fully off-grid, utilises a solar PV array and a small wind turbine to provide a continuous 230v ac supply to a permanently occupied house and outbuildings. The key features of the system are as follows:

- (i) A 1080 watt solar PV array of six panels is configured as a nominal 72-volt source, and supplies the input to a MPPT (maximum power-point tracking) solar controller [7], which provides a 24-volt dc output, and is the primary energy source.
- (ii) Energy is stored in a 24-volt deep-cycle lead-acid battery set.¹ These batteries are nominally rated at 670 amp-hours, or 16.08 kwh for the 24-volt set.
- (iii) A small wind turbine provides a secondary energy source. This is a 24-volt three phase ac turbine, the output of which is connected via a three-phase bridge rectifier directly to the batteries. The turbine has a nominal rating of 400 watts, but provides this level of power only in very strong wind conditions.

¹ Henceforth referred to as *the batteries*.

- (iv) The 24-volt dc supply from the batteries is converted to a standard 230-volt 50-hertz ac supply for the house by a sine-wave inverter/charger. This unit is rated at 1600 watts continuous, and at 2200 watts peak for up to 30 minutes [5].

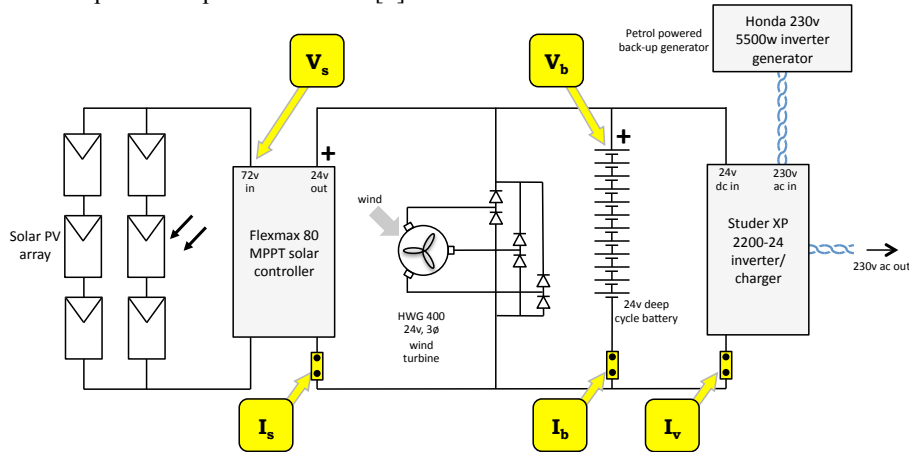

Figure 4: An overview of the Pauaeke off-grid electricity system, showing the two voltages (V_s and V_b) and the three currents (I_s , I_b and I_v) measured by the Pentametric monitor.

- (v) A back-up petrol powered generator is available when needed. It generates 230-volts ac (inverter stabilised) and connects to the inverter/charger unit. When the generator is running, the inverter/charger switches automatically to charge mode, and charges the batteries from the generator input, while at the same time switching the generator input directly through to the 230-volt house supply. The maximum charge rate through the inverter/charger is set to 1600 watts. Typical usage of the generator is \sim 4-5 hours per week, on average over a year.
- (vi) Average daily electricity consumption is \sim 5kwh. Most common appliances and power tools are used from the inverter 230-volt supply. This includes lighting, TV/entertainment, computers, refrigerator, freezer, vacuum cleaner, washing machine, iron, microwave, toaster, etc., but other than for the few exceptions in this list, electricity is not used for heating and cooking.
- (vii) On relatively rare occasions when equipment consuming more than 2.2kw needs to be used, for example, sheep-shearing machinery, this is powered directly from the back-up generator.

Figure 4 also shows the monitoring facilities which have been installed in the off-grid system. Of principal interest here are those sensors for monitoring the 24-volt sub-system; the battery voltage and the currents associated with the batteries. For this function, a Pentametric Battery Monitor has been used [13]. This unit is able to continuously sample up to two dc voltages and up to three dc currents, which it then outputs via an RS232 communications port. In the Pauaeke installation, the five quantities which are monitored (see Figure 4) are:

- The battery voltage, V_b , nominally 24 volts;
- The solar array voltage, V_s , nominally 72 volts;
- The battery current, I_b , which is normally in the range from -90 amps (maximum discharge rate at 2200 watts) to +67 amps (maximum charge rate at 1600 watts);
- The solar charge current, I_s , which is normally in the range from 0 to 45 amps (maximum panel output at 1080 watts);
- The inverter/charger current, I_v , which is normally in the range from -90 amps to +67 amps.

The current shunts are arranged so that the polarity of the three monitored currents are all positive for battery charging mode. In other words, with reference to Figure 4 and Formula 1, I_b is positive when the battery is charging; I_s is positive when the solar array is active and the battery is charging; and I_v is normally negative when the inverter/charger is drawing current. I_w is not a directly monitored current, but can be calculated from the other three, and represents the charging contribution of the wind turbine.

$$I_b = I_s + I_v + I_w \quad (1)$$

The output from the Bogart monitor is connected to an Intense PC [14] via an RS232-to-USB conversion cable. The Intense PC, a low-power consumption display-less computer ideally suited to off-grid data logging applications such as this, is programmed to sample the Pentametric outputs at 10-second intervals, and to record these, making them available for periodic download via an Internet connection. Alahmari [15] provides a more detailed description of the data logging software, and of the

other off-grid system parameters (those on the 230 volt side) which are recorded in addition to the Pentametric outputs described.

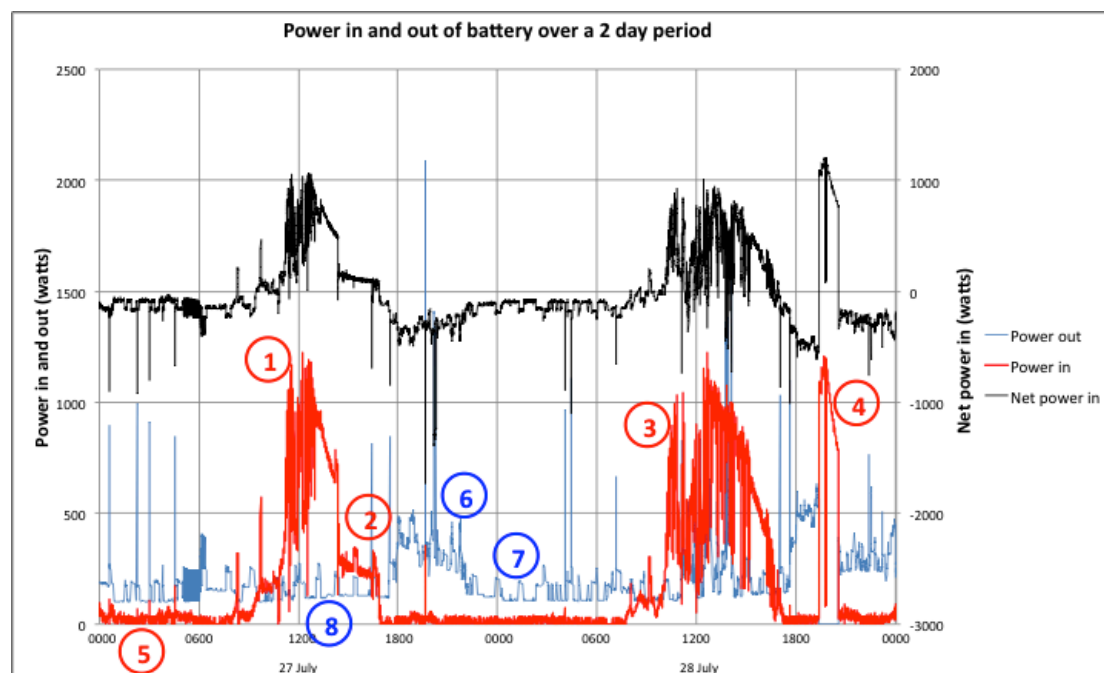

Figure 5: Detail of power in and out of the Pauaekē batteries over two days, showing the cyclic nature of both consumption and generation.

It is worth noting typical behaviour of the off-grid system in operation. Figure 5 provides a detailed view of just two day's data of power in and out of the batteries, together with the difference between these two values shown as the net power flow to the batteries. There are several points worthy of note in this diagram; the numbers refer to the corresponding reference points on the graph:

1. Power **in** is dominated by the daily solar cycle, on this occasion seen to start seriously at around 11am.
2. The sudden drop-off from the solar panels at around 2.30pm is the result of a charger back-off; the solar controller interpreted the battery behaviour as showing near full charge, so switched to absorption mode [6].
3. On the second day there was some cloud cover, causing the solar input to fluctuate continuously. The fact that there is no charger back-off later on this day indicates that because of the cloud cover, the batteries did not reach full charge.
4. That indication is further supported by the fact that the back-up petrol generator was activated at around 7.30pm for approximately 90minutes. Note that the power out of the batteries drops to zero during this charge phase, because the 230 volt house supply is provided directly from the generator when it is running (refer to (v) above).
5. The low-level background generation of ~ 50-100 watts represents the output from the wind turbine.
6. Consumption is characterised by heavier evening usage of ~ 300 watts average from 6pm to 10pm.
7. The characteristic signature of a thermostatically controlled load, around 100 watts regularly switching on for 12 minutes at approximately 1 hour intervals, is due to a refrigerator.
8. The base load of approximately 100 watts represents devices on standby, clocks, and the Intense PC.

In summary, from this short observation, it is clear that there are regular charge/discharge cycles on a daily basis, although the solar charge cycle may not occur on a cloudy day, and specific but irregular loads may interfere with this. Although not every day sees a full charge event nor a battery empty event, there is a regular daily ebb and flow of charge to the batteries, and every day sees some charging and some discharging activity.

The next section examines the monitored data in more detail, and develops an approach to calculating the state-of-charge of the batteries, and for recalibrating the parameters used in this calculation on a regular basis.

3 Ampere-Hour Counting and Recalibration

The approach taken in the proposed B3SOC algorithm is to treat the batteries effectively as “black box” with a small number of characteristics and attributes, but to exploit a full historical record of these parameters. Some of these attributes are accepted as being dynamic, and from time to time, and on the occurrence of certain events, their values will be modified to fit the currently known facts (recalibration). The model itself is to be kept as simple as possible, but the notion of adaptive parameters exploits the relatively detailed knowledge of the past system history implicit in the 10-second sampling. It is a passive model that is based solely on data and observation rather than complex chemistry and physics, and one which does not involve specific intervention in the charging/discharging process.

In terms of monitoring the battery SoC, the data obtained from the Pentametric monitor provides detailed records of battery voltage and current; from these there are several important battery parameters and events which it is possible to calculate or identify, and which potentially play a part in the SoC calculations.

- The present value of the power in or power out of the battery set can be calculated at each 10-second increment, using the monitored battery voltage and battery current, and from this, an accurate record of total energy in and total energy out can be maintained. This is effectively using the integration of the battery power flow to maintain a total stored energy figure, the “ampere counting” or “Coulomb counting” approach to SoC estimation [1], [4]. Figure 6 shows this power in/out data over a 12-day period for Pauaeke, very clearly revealing the overall daily cycles in both, and the continuous use nature of the installation.

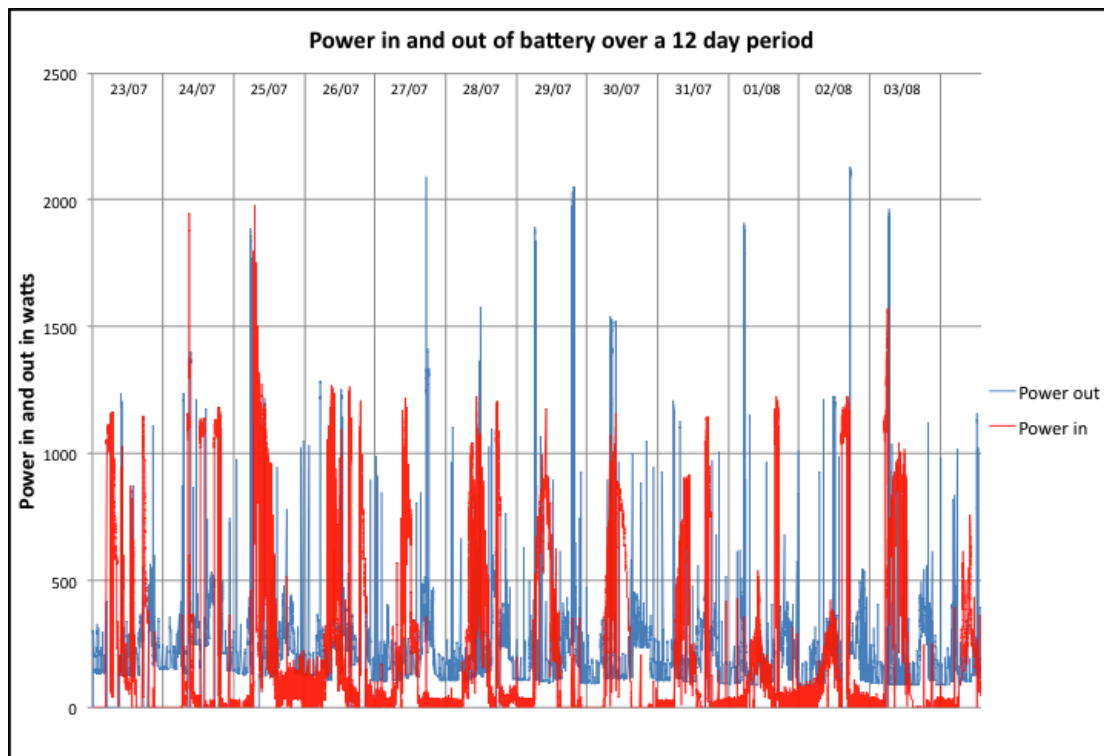

Figure 6: Power in and out of the Pauaeke batteries sampled at 10-second intervals over the 12-day period 23/07/13 to 03/08/13.

- Charge and discharge rates at each 10-second interval can be calculated, as these may influence the interpretation of full charge or zero charge events.
- Inverter/charger *low voltage shut-down* events (LVSDs) can be inferred from the data when the inverter load current suddenly drops to zero and the battery voltage is low.
- Charger back-off events, which may indicate full-charge, can also be inferred when the charge current drops for no apparent reason at a higher battery voltage. These events are, however, not

a reliable indicator, because the **SoC** at which they occur is very dependent on the charge current.

Three other parameters are potentially useful in determining **SoC**. These are:

- Battery temperature; while this can be readily monitored, it is not presently available for the Pauaeke installation, so has not been used at this stage in the algorithm development.
- Battery charge efficiency is not known *a priori*, and is variable, dependent on a range of factors [8], [11]. It is suggested, however, that it should be possible to approximate this with a constant, provided that its value is frequently recalibrated. Typical operational patterns, as indicated in Figure 5, suggest that recalibration events will occur in a scale of days, rather than weeks, lending support to this concept.
- Auto-discharge rate – the rate at which the batteries lose charge when not being used. Given the continuous use aspect of the Pauaeke installation (refer to Figure 5), and the suggestion that typically the rate is as small as 0.2%/day [4] this parameter has not been included at this stage of the algorithm development.

On the basis of these parameters and assumptions, the B3SOC black box model has been developed as follows.

- The batteries are assumed to be a simple energy storage system with a charging efficiency C_{eff} (≤ 1). If energy J watt-hours is delivered into the batteries, then the actual energy stored is $C_{\text{eff}} \times J$ watt-hours, which can be recovered in full at a later time (the discharge efficiency is assumed to be 100%). B3SOC assumes an appropriate initial value of C_{eff}^2 , but adapts this value continuously on the basis of observation and history. In Figure 7 the energy in and out data shown earlier in Figure 6 has been combined assuming 100% efficiency (7(a)) and 80% efficiency (7(b)). These graphs represent the net energy into the batteries, and show the integral of the difference between the power in and power out of Figure 6, taking into account the relevant charge efficiency value.

In Figure 7(a) it is evident that the maximum and minimum charge levels established by day 3 of the observation are quickly overtaken as the apparent charge level escalates on a daily basis. However, Figure 7(b) gives strong support for an initial value of C_{eff} of 80%; the maximum and minimum values established in the first three days provide a stable operating range over the remainder of the observation of around 4500 watt-hours, consistent with the known daily use of ~ 4500 watt-hours, and the regular cycling of the batteries between 0% and 100% as revealed by observed charger back-off and LVSD events.

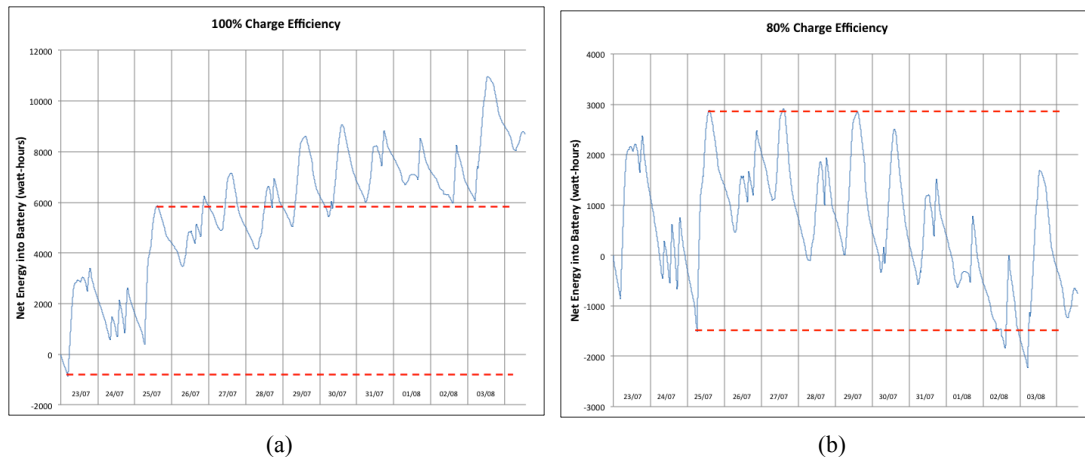

Figure 7: Net energy into the batteries (effectively energy stored) from the data of Figure 6, assuming (a) an overall charge/discharge efficiency (C_{eff}) of 100%, and (b) an efficiency of 80%.

- The batteries can be characterised by a maximum capacity for recoverable energy.³ This full charge capacity (or 100% charge level) is represented by E_{100} in watt-hours. This is not the same

² C_{eff} is initially set to 80%, a value which has proven to be remarkably accurate. Suggestions in the literature are that this composite charge/discharge efficiency typically varies from 60% to 90%, depending on a variety of other factors [11].

³ Note that the more common approach to recoverable battery energy is to work with two parameters – maximum and minimum charge levels, recognising that most charging control systems protect the batteries from unwarranted damage by not allowing the actual charge level to fall below some minimum (often 60 –

as the nominal rating of the batteries; it represents the amount of energy that can be extracted without damaging the batteries. Even for deep-cycle batteries, this will typically be less than 40% of their rating, and it also decreases with battery age [16]. The value of E_{100} is continuously modified to align with observation and history. Initially, at time t_0 , its value is assumed to be zero, but as will be seen later, its real value is relatively quickly established.

- At any time t , the battery is assumed to hold deliverable energy E_t . Normally E_t will have a value between zero and E_{100} . If during a given time interval, energy E_{in} is delivered to the battery set and energy E_{out} is extracted, then the change in energy stored in the battery can be described as:

$$\Delta E_t = C_{eff} \times E_{in} - E_{out} \quad (2)$$

Since the algorithm has no knowledge of history at time t_0 , the initial value of E_t is assumed to be zero, and is then modified on the basis of observation.

- The battery state-of-charge can then be calculated at any time t as:

$$SoC = E_t / E_{100} \quad (3)$$

Following the initial assumption of values for the three key parameters ($C_{eff} = 0.8$; $E_{100} = 0$; $E_t = 0$), observation, as in Figure 7(b), would suggest that after a few charge/discharge cycles (in this case 3 days proves adequate), a value for E_{100} can be readily established (the difference between the upper and lower dotted lines – ~ 4300 watt-hours) and an origin or base value for E_t (the lower dotted line – ~ -1500 watt-hours on the original axis, implying that the actual initial value was 1500). Subsequent events then need to be interpreted and the information used to recalibrate these three parameters as time progresses. Recalibration is vital for several reasons that have already been discussed, but principally that (i) charge efficiency is not in fact a constant, and varies, for example, with temperature and charge level, and (ii) events which imply either full or empty may occur over a range of charge levels, so that our initial, and subsequent estimates of maximum charge and instantaneous charge may be in error. The cumulative effect of erroneous calculations on the value of E_t , and consequently on the SoC estimate, is very evident from Figure 7(a). As pointed out by Piller et al [1] in relation to ampere counting, “...the method is easy and reliable as long as the current measurement is accurate and enough recalibration points are available.”

There are four situations which occur reasonably frequently with a continuous use off-grid system which both imply that recalibration is required, and provide sufficient information to perform this recalibration. These are:

- a. A *battery empty* event occurs when the calculated SoC is above 0%;
- b. The calculated SoC falls below 0% without a *battery empty* event occurring;
- c. The calculated SoC rises to greater than 100% without a *battery full* event occurring;
- d. A *battery full* event occurs when the calculated SoC is less than 100%.

The following paragraphs and diagrams describe these four situations, and in each case show which of the parameters need(s) to be modified. In order to avoid frequent minor adjustments which are of little consequence, tolerance bands of $\pm 5\%$ have been introduced around the 0% and 100% values. It should be noted that errors in charge efficiency C_{eff} are the most serious issue, since their effect is cumulative, whereas errors in maximum charge E_{100} simply give a (constant) proportional error in the SoC calculation (if E_{100} is 20% too high, then the calculated SoC will be 20% too high). Given the critical nature of C_{eff} , then the more reliable or deterministic events are used to recalibrate this value, the *battery empty* events. *Battery full* events, which as suggested earlier are a less reliable indication, are used to recalibrate the less critical E_{100} value. In either case, if an inappropriate adjustment is made to one of these parameters, this will be revealed and corrected in subsequent recalibration opportunities.

Figure 8 describes recalibration situation (a), where an overall upward drift of calculated SoC is revealed by a *battery empty* event (LSVD) occurring when the calculated SoC is greater than +5%. Although this situation could be ignored if the power draw over the previous two minutes (for example) was considered to be unusually high (say $>50\% P_{max}$), since this may have inadvertently triggered the LSVD, it will generally indicate that the charge efficiency value C_{eff} is too high. Recalibration requires the following steps (refer to Figure 8):

1. The E_t and SoC values should both be reset to zero;
2. The C_{eff} value is recalculated over the previous 7 days, using the E_t value from that point (E_{t-7}), together with the total energy in (E_{in}) and total energy out (E_{out}) over that 7 day period:

$$C_{eff} = (E_{out} - E_{t-7}) / E_{in} \quad (4)$$

70%). This algorithm, based solely on observation, is aware only of the delivered charge, and not of any residual but unobtainable energy. Hence the use of a single parameter to represent the maximum deliverable charge.

3. The E_{100} value remains unchanged.

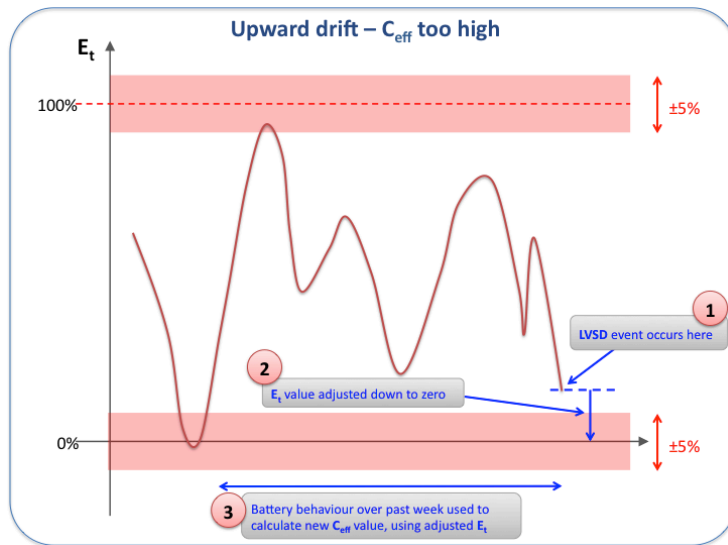

Figure 8: Upward drift of calculated charge level caused by the charge efficiency value, C_{eff} , being too high, and the correction of this drift.

This recalibration is based on the assumptions (i) that the LVSD is a valid *battery empty* event, and (ii) that any erroneous drift in the E_t value is confined to the past 7 days. The latter assumption is reasonable if recalibration opportunities generally occur at less than 7 day intervals.

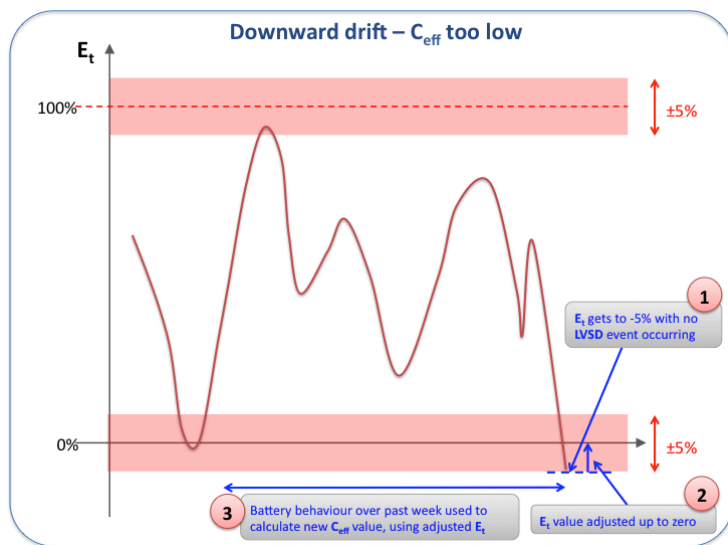

Figure 9: Downward drift of calculated charge level caused by the charge efficiency value, C_{eff} , being too low, and the correction of this drift.

Downward drift of the E_t (and hence **SoC**) calculations is shown in Figure 9, and will be flagged by the E_t value falling below -5% without a *battery empty* event (LVSD) occurring. This situation, corresponding to (b) above, can be interpreted as resulting from a C_{eff} value which is too low, and the required recalibration is exactly the same as for the previous case.

It is possible that a more radical adjustment of C_{eff} will be required, since the battery may continue to discharge without a *battery empty* event occurring, but if this is the case then a sequence of these recalibrations will be triggered until either battery discharge ceases, or a *battery empty* event does occur.

Figures 10 and 11 describe situations which provide an opportunity to recalibrate the total battery capacity parameter, E_{100} . In Figure 10, the calculated **SoC** has reached a value of 105% without a *battery full* event occurring (recalibration situation (c) above). As **SoC** is calculated as the ratio E_t / E_{100} , this situation suggests that the E_{100} value is too low, and needs to be adjusted upwards to be equal to E_t . This is the only adjustment required in this situation, as a recalculated **SoC** will now be

exactly 100%. Of course, as suggested in the previous paragraph, the battery charge level may continue to rise without a *battery full* event, in which case there may result a sequence of these recalibrations until charging ceases, or a *battery full* event does occur.

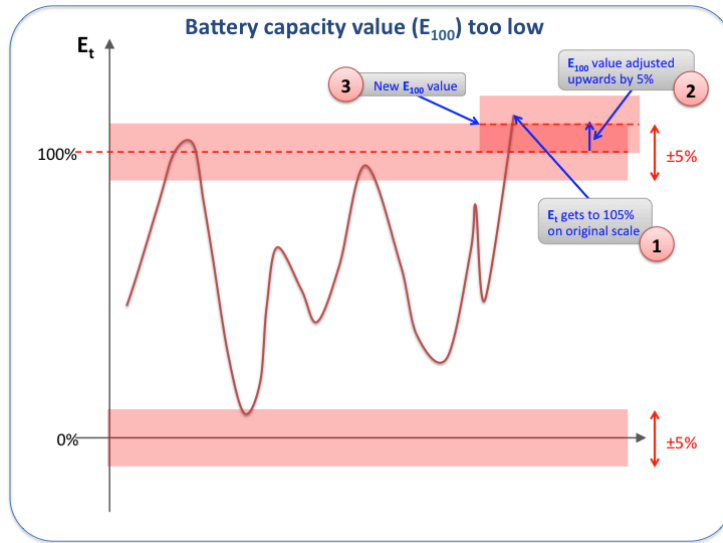

Figure 10: Battery full-charge estimate, E_{100} , proves to be too low when the battery reaches 105% charge and the charging module does not recognize a full-charge state.

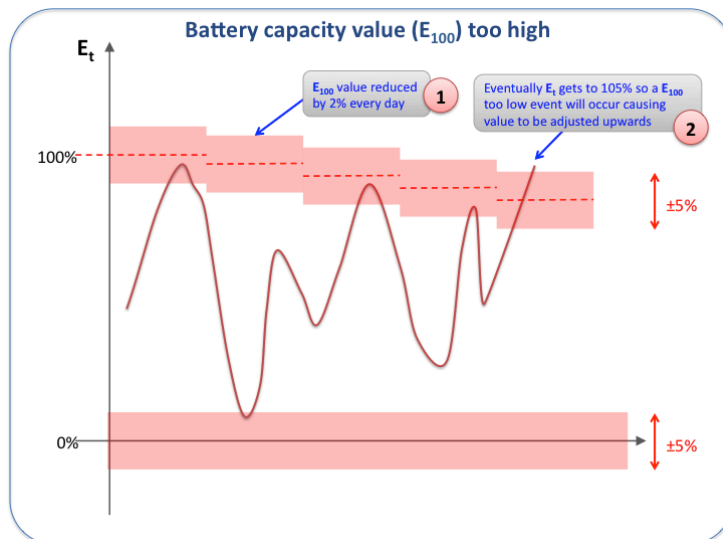

Figure 11: To ensure an isolated high charge level does not continue to distort SoC calculations, the full-charge estimate, E_{100} , can be reduced by 2% each day until a *full-charge estimate too low* situation (see Figure 10) occurs. This ensures a reasonably frequent ($\sim <10$ days) recalibration of the E_{100} value.

Recalibration situation (d) is treated in a different way, as shown in Figure 11. It is generally preferable that the E_{100} estimate is too high rather than too low, since the former will provide a conservative value for SoC. Because *battery full* events (flagged by charger back-off) are less reliable, and may commonly occur at any SoC $>70\%$, it was decided not to automatically adjust E_{100} downwards when situation (d) occurred – battery full at SoC $< 100\%$ – but instead to provide a different mechanism for ensuring that E_{100} is recalibrated downwards if its value is too high. This approach, illustrated in Figure 11, exploits the concept of *data aging* [17]. Every 24 hours (at midnight) the existing value of E_{100} is reduced by 2%. This means that, left untouched, E_{100} would reduce to $\sim 85\%$ of its initial value over a week. However, during this time it is inevitable that a high charge level will occur, taking E_t above the current day's value of E_{100} , so creating situation (c) which will adjust the E_{100} value upward from its downward declining path, as indicated in Figure 11. This technique exploits the fact that the absence of a *battery full* event is a more trustworthy situation (the battery is genuinely not yet full) than the occurrence of a *battery full* event (the battery is probably at some level above 70% SoC).

This section has described the development of the B3SOC algorithm, covering the “Coulomb counting” method, the general “black-box” approach requiring little or no detail knowledge of the actual installation and its specification, and the use made of recalibration opportunities. The following section traces the application of the algorithm to a real 3-week Pauaeke data set, identifying notable and critical points in this data.

4 Application of the B3SOC algorithm

The operation of the B3SOC algorithm is best explained with reference to the graphs and notable points of Figure 12. This shows the algorithm in operation, and plots the changes in calculated E_t (energy stored in the batteries), as well as changes in the estimate of E_{100} (maximum capacity), and the resulting calculated state-of-charge (SoC) at each data point, over the 21-day sample period.

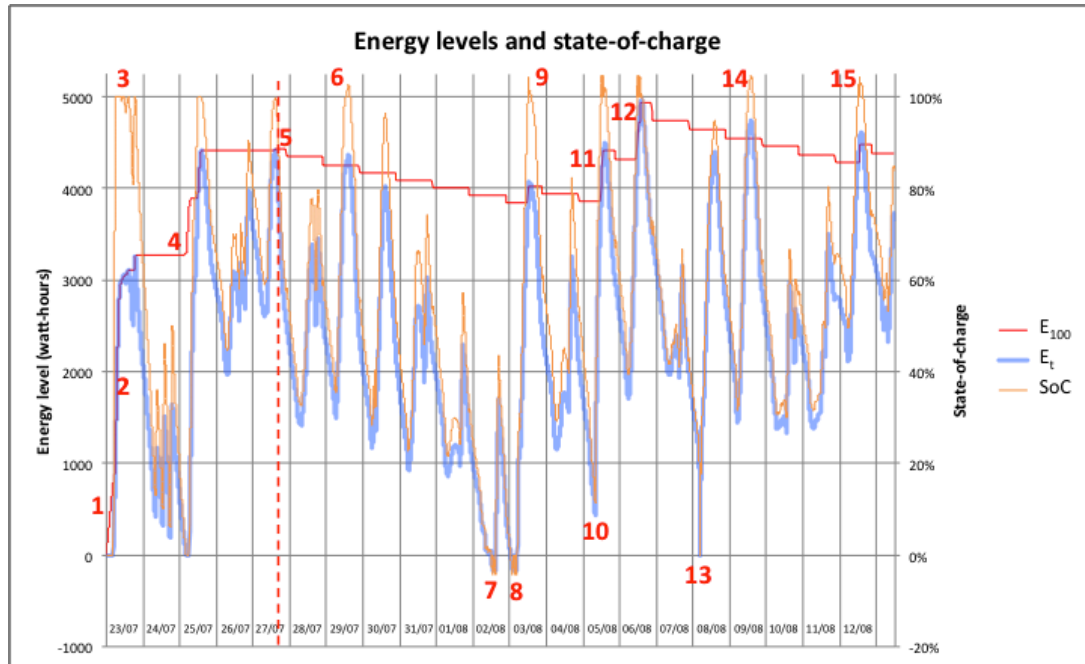

Figure 12: Algorithm and parameter development based on the 3 week sample data, showing battery stored energy E_t , battery maximum capacity E_{100} , and state-of-charge SoC . The overlaid numbers indicate notable points which are described in the text.

With reference to this graph, and the discussion of Section 3, the following general points should be noted:

- At the outset, all three plotted parameters are assumed to be zero, as there is no prior knowledge of their actual values; ie actual energy stored, maximum capacity, and state-of-charge.
- The initial assumed value of the charge efficiency C_{eff} is 80%; ie on average only 80% of the energy delivered to the battery is actually stored and available for re-use.
- Within the first 3 days of the algorithm’s operation, the maximum capacity figure, E_{100} , becomes well established (at around 4400 watt-hours) meaning that from this point onwards, the SoC figures are valid.
- Any error in the *charge efficiency* (C_{eff}) value shows up as a general upward (C_{eff} too high) or downward (C_{eff} too low) drift in the E_t and SoC values, as described in detail in Section 3. However, provided the maximum (E_{100}) value is established relatively quickly (say in 5 days) then the impact of any C_{eff} drift on this value will be minimal.

A more detailed understanding of the operation of the algorithm is provided with reference to the numbered points/events on the graph, as follows:

1. At this point, E_{100} is increasing because E_t was assumed to have an initial value of zero, but it is getting less (ie tending negative), so E_{100} is being increased in order that E_t does not go below zero (ie E_t is held at zero while the batteries continue to discharge). E_{100} represents the highest value of E_t seen so far.
2. E_{100} continues to increase in this region, following the rise of E_t as charging commences.

3. As the true E_{100} value has not yet been established, the **SoC** value shows as 100% for the highest charge level (E_t) so far seen.
4. E_{100} continues to track the maximum value of E_t so far, but is also driven up if E_t tries to go negative, as in (1) above.
5. Five days have passed, so the algorithm freezes E_{100} at this point, assuming a “stable” value has been established (4430 watt-hours). (The daily 2% drop in its value is also introduced at this stage.) From this point onwards **SoC** values should be considered valid, and *battery full* and *battery empty* events (or their absence) can be used to recalibrate the parameters.
6. **SoC** goes over 100% at this point, but not as high as 105% (the tolerance region), so no recalibration occurs.
7. **SoC** drops to -5% with no *battery empty* event occurring, suggesting that C_{eff} is too low, in that the batteries hold more charge than the parameters predict (Figure 9). A new value of C_{eff} is calculated from the power in and out of the battery over the previous 7 days (81%), and E_t is reset to zero. Although E_t (and hence **SoC**) continues to fall for a period, it does not fall to -5%, so no further recalibration action occurs here.
8. **SoC** again drops to -5% with no *battery empty* event, so C_{eff} is recalculated, this time to 82%. Very shortly afterwards **SoC** again drops to -5% and C_{eff} is recalculated to 82.5%; this is repeated once again giving a value for C_{eff} of 83.2%. Shortly afterwards a *battery empty* event (LVSD) does occur, but as **SoC** is at 0%, no action from the algorithm is required; the 0% value has been confirmed.
9. Here the **SoC** rises up to 105% without a *battery full* event, so E_{100} is increased to bring **SoC** down to 100% (Figures 10 and 11). The new value (4020 watt-hours) is lower than that set in step 5, as a result of the 2% drop in the original value each day. At this stage, the net effect is a correction downwards from that original value. Although the **SoC** continues to rise, it goes only to 101% before falling again, so no further action is triggered.
10. Here a *battery empty* event (LVSD) did occur at **SoC** = 11% (> 5%), but as the power draw was high (~1.3kw = 59% P_{max}) over the previous two or more minutes, no recalibration action was carried out.
11. The **SoC** again rises to 105%, so E_{100} is increased to bring this down to 100%, as shown in Figures 10 and 11. Subsequently **SoC** continues to rise, and reaches 105% again, with E_{100} adjusted up again, and then a third time as well, before **SoC** starts to fall. The final adjusted value of E_{100} , 4407 watt-hours, is close to the original estimate from step 5.
12. At peak solar time the following day, there are again a sequence of three 105% **SoCs**, as in step 11, with each resulting in an increase to E_{100} , and producing an ultimate value of 4930 watt-hours.
13. A *battery empty* event (LVSD) event occurs at 20% **SoC**, the situation described in Figure 8. The average power draw over the previous two minutes was ~380watts (= 17% P_{max}), so this is acknowledged as requiring recalibration of C_{eff} . E_t is reduced to 0, and C_{eff} is recalculated using the previous 7 days data (down to 81.7%).
14. **SoC** rises to 104% as solar charge peaks for the day, but as this is within the $\pm 5\%$ tolerance range, no recalibration occurs.
15. **SoC** rises to 105%, so E_{100} is recalibrated upwards, to 4472 watt-hours.

This section has described the algorithm in operation, and shown the **SoC** values produced in real-time by the algorithm. In the following review section, these values are analysed with hindsight, to establish the accuracy of the approach.

5 Analysis and Conclusion

The aim of this work has been to develop a black box approach to estimating in real-time the state-of-charge (**SoC**) of the batteries in a continuous use off-grid electricity system. It was suggested at the outset that the required accuracy for this **SoC** estimate was similar to that of the fuel gauge in a car ($\pm 12.5\%$). It was also established that under the circumstances (particularly continuous use), **SoC** calculations at best are not precise, nor deterministic, and even with hindsight, the “true” value of the **SoC** at any point in history can still only be estimated, but with the advantage of knowing about subsequent recalibrations which may have rendered the original **SoC** in error.

5.1 Errors in the Calculated State-of-Charge

In order to assess the accuracy of the B3SOC algorithm, retrospective analysis has been applied to the original calculations shown in Figure 12, and the consequent error in the real-time **SoC** value has been

calculated. The calculated error is shown in Figure 13. Before discussing this graph, it is necessary to describe the means by which the “true” SoC has been calculated.

There are three key parameters in the B3SOC algorithm which with hindsight may need to be modified, and consequently those modifications may have an impact on the historical value of SoC.

1. The charge efficiency, C_{eff} . This value is subject to recalibration, for example at points 7, 8 and 13 in Figure 12. When it is recalibrated, data from the previous week is used (this assumes that a week ago the old value was correct, but since then has been incorrect). In retrospect, this new value should be applied to all energy into the batteries over the previous week, and consequently will impact those historical values of SoC.
2. The maximum charge level, E_{100} . This value is also subject to recalibration, in the case of the data under discussion, at points 9, 11, 12 and 15 (Figure 12). Although there is the 2% reduction in this value every midnight, this is not a recalibration *per se*, but is intended ultimately to initiate one. For the retrospective calculation, a straight line interpolation of the E_{100} value is carried out between actual recalibration points.
3. The deliverable energy in the batteries, E_t . Although this value is not directly subject to recalibration, this is implicit in the low charge situations illustrated by Figures 8 and 9. In those cases (7, 8 and 13), as mentioned in (1) above, as the C_{eff} value is modified for the previous week, then so too will a recalculation of E_t over this period be required.

For completeness, for the initial 5-day settling-in period, the values of the three parameters at the end of that period have been retrospectively applied to the full period.

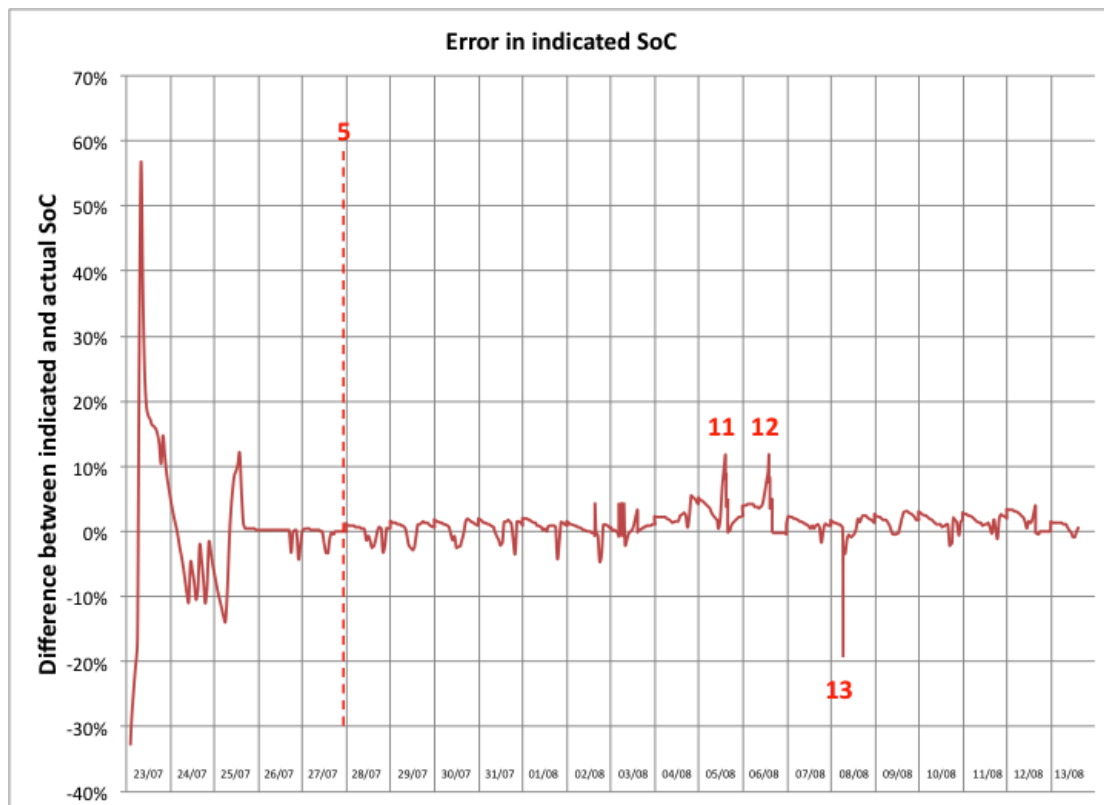

Figure 13: A comparison of the retrospectively established SoC with the real-time estimate produced by the B3SOC algorithm. The data shown is the percentage point difference between the two values, and the overlaid numbers refer to specific points shown in Figure 12.

From Figure 13 it can be seen that once the initial 5-day settling-in period has passed (point 5 in Figure 13), the real-time calculated SoC provides an indication of charge level typically within $\pm 5\%$ of the “true” SoC (actually, it is within $\pm 5\%$ after only 3 days). There are three exceptions to this, all occurring at recalibration points (11, 12 and 13 in Figures 12 and 13). Each of these departures is characterised by a single point on the graph (Figure 13) where data points are at 1-hour intervals, indicating that an error of this magnitude persisted for less than 2 hours. Each of the points 11 and 12 represents an upward recalibration of the E_{100} value, which has the effect of a step reduction in SoC (formula 3). In fact, in both of these cases the error is exactly 12%, the difference between the real-time SoC (105%) and the retrospectively calculated “true” SoC (93%). The more significant error, and the

only one falling outside the specification of $\pm 12.5\%$, is that occurring at point 13. Note that the error is small immediately before and after the recalibration event, suggesting (i) that the gross recalibration, triggered in this case by an LVSD at an SoC greater than zero, was an over-reaction, and (ii) that even so, the consequences of that over-reaction diminish quickly. It is likely that refinement of the algorithm in relation to this could be achieved.

5.2 Summary

In summary, this paper has described an algorithm for estimating in real-time the state-of-charge of lead-acid batteries in an off-grid electricity system, where they are effectively in continuous use, making it impossible to use approaches which require “at rest” measurements. The technique which is based solely on battery voltage and current measurement, with frequent automatic recalibration of critical parameters using this data, has produced results which with few exceptions are within $\pm 12.5\%$ of the “true” state-of-charge, sufficient for fuel-gauge accuracy.

A detailed pseudo-code description of the B3SOC algorithm is included as an appendix to this report.

6 References

1. Piller, S., Perrin, M., Jossen, A.: Methods for state-of-charge determination and their applications. *Journal of Power Sources*, **96** (1), 113–120 (2001)
2. Sato, S., Kawamura, A.: A new estimation method of state of charge using terminal voltage and internal resistance for lead acid battery. *Power Conversion Conference, 2002. Proceedings of PCC-Osaka 2002*, **2**, 565–570 (2002)
3. Scott, J., Pennington, K., Schwarz, S., Rowe, P.: Vehicle lead-acid battery state-of-charge meter. *Proceedings of IECON 2011, the 37th IEEE International Conference on Industrial Electronics*, 7–10 November 2011, Melbourne Australia, 1660–1664 (2011)
4. Zhou, Wei., Yang, Hongxing., Fang, Zhaohong.: Battery behavior prediction and battery working states analysis of a hybrid solar–wind power generation system. *Renewable Energy*, **33** (6), 1413–1423 (2008)
5. Studer XP-Compact XPC 2200-24 Manual, http://www.studer-inno.com/?cat=sine_wave_inverter-chargers&id=433
6. Wong, Y.S., Hurley, W.G., Wölfle, W.H.: Charge regimes for valve-regulated lead-acid batteries: Performance overview inclusive of temperature compensation. *Journal of Power Sources*, **183** (2), 783–791 (2008)
7. OutBack Power Flexmax series charge controller manual, <http://www.outbackpower.com/downloads/documents/0307121010258900-0009-01-00RevB.pdf>
8. Bode, H.: *Lead Acid Batteries*. Wiley, NY (1977)
9. Manwell, J.F., McGowan, J.G.: Lead acid battery storage model for hybrid energy systems. *Solar Energy*, **50** (5), 399–405 (1993)
10. Perez, R.: Lead-acid battery state of charge vs. voltage. *Home Power*, **36**, 66–69 (1993)
11. Stevens, J.W., Coney, G.P.: A study of lead-acid battery efficiency near top-of-charge and impact on PV design. *Proc IEEE Photovoltaic Specialists Conf*, Washington DC, 1485–1488 (1996)
12. Chatfield, C.: *The analysis of time series: an introduction*. 4th ed. Chapman & Hall, London (1989)
13. Pentametric System Manual, <http://www.bogartengineering.com/support/manuals>
14. Intense PC, <http://www.fit-pc.com/web/products/intense-pc/>
15. Alahmari, M.M.: *Off-grid Energy Monitoring*. Unpublished master’s thesis, University of Waikato, Hamilton, New Zealand (2013)
16. Divya, K.C., Østergaard, J.: Battery energy storage technology for power systems—An overview. *Electric Power Systems Research*, **79** (4), 511–520 (2009)
17. Zhang, J., Izmailov, R., Reiningger, D., Ott, M.: Web caching framework: analytical models and beyond. *IEEE Workshop on Internet Applications*, 132–141 (1999)

Appendix

Detailed B3SOC Algorithm Description

1. Initialise:¹

Total power into battery:	$P_{in} \leftarrow 0;$
Total power out of battery:	$P_{out} \leftarrow 0;$
Energy stored in battery:	$E_t \leftarrow 0;$
Maximum battery capacity:	$E_{100} \leftarrow 0;$
Charge efficiency:	$C_{eff} \leftarrow 0.8;$

2. For the first five days the following sequence will establish the value for E_{100} :
 - a) Take next data record to get values for battery voltage V_b , battery current I_b , and inverter current I_v ;
 - b) Calculate power increment P_{inc} , actual battery increment B_{inc} , and update P_{in} and P_{out} :
 - i. Power increment: $P_{inc} \leftarrow V_b \times I_b \times \text{time increment};$
 - ii. If $P_{inc} > 0$ then /power flow into battery

$P_{in} \leftarrow P_{in} + P_{inc}$	
$B_{inc} \leftarrow C_{eff} \times P_{inc}$	/C _{eff} determines how much of P_{in} actually stored in battery
 - else /power flow out of battery

$P_{out} \leftarrow P_{out} - P_{inc}$	/keep P_{out} as a positive value
$B_{inc} \leftarrow P_{inc};$	
 - c) Calculate the actual stored energy E_t , recognising that in this settling-in phase it may be trying to go below zero or above E_{100} ; in either case need to adjust E_{100} upwards:²

If $(E_t + B_{inc}) < 0$ then /new value would be less than zero
$E_{100} \leftarrow E_{100} - (E_t + B_{inc})$
$E_t \leftarrow 0$
else
$E_t \leftarrow E_t + B_{inc}$
If $E_t > E_{100}$ then /new value is greater than E_{100}
$E_{100} \leftarrow E_t$
 - d) Calculate the state-of-charge at this sample point:

$SoC \leftarrow E_t \div E_{100}$

 - e) continue looping from 2(a)

3. After 5 days, the algorithm moves to its steady state, assuming that an appropriate E_{100} value has now been established and that the initial charge efficiency estimate was approximately right. At each data point the SoC is calculated, and checks are made for opportunities to recalibrate the E_{100} and C_{eff} values:
 - a) Take next data record to get values for battery voltage V_b , battery current I_b , and inverter current I_v ;
 - b) Calculate power increment P_{inc} , update P_{in} and P_{out} , and calculate new value for stored charge E_t :
 - i. Power increment: $P_{inc} \leftarrow V_b \times I_b \times \text{time increment};$
 - ii. If $P_{inc} > 0$ then /power flow into battery

$P_{in} \leftarrow P_{in} + P_{inc}$	
$E_t \leftarrow E_t + C_{eff} \times P_{inc}$	/C _{eff} determines how much of P_{in} actually stored in battery
 - else /power flow out of battery

$P_{out} \leftarrow P_{out} - P_{inc}$	/keep P_{out} as a positive value
$E_t \leftarrow E_t + P_{inc}$	

- c) Calculate the state-of-charge at this sample point:

$$\text{SoC} \leftarrow E_t \div E_{100}$$
- d) Check for upward drift:³
 If (LVSD⁴) and (SoC \geq 5%)⁵ and (2 minute load $>$ 500watts)⁶ then /upward drift occurring:
 /C_{eff} is too low

$$E_t \leftarrow 0$$

$$\text{SoC} \leftarrow 0\%$$
 Calculate ΔE_b , ΔP_{out} and ΔP_{in} using values from 7 days back,⁷ and use these to calculate a new value for C_{eff}:

$$C_{eff} \leftarrow (\Delta E_t + \Delta P_{out}) \div \Delta P_{in}$$
- e) Check for downward drift:⁸
 If (not LVSD⁴) and (SoC \leq -5%)⁵ then /downward drift is occurring: C_{eff} is too low

$$E_t \leftarrow 0$$

$$\text{SoC} \leftarrow 0\%$$
 Calculate ΔE_b , ΔP_{out} and ΔP_{in} using values from 7 days back,⁷ and use these to calculate a new value for C_{eff}:

$$C_{eff} \leftarrow (\Delta E_t + \Delta P_{out}) \div \Delta P_{in}$$
- f) Check for E₁₀₀ too low:⁹
 If (SoC \geq 105%)⁵ then /E₁₀₀ is too low

$$E_{100} \leftarrow E_t$$

$$\text{SoC} \leftarrow 100\%$$
- g) Check for E₁₀₀ too high:¹⁰
 If (time is end of day¹¹) then /E₁₀₀ is too high

$$E_{100} \leftarrow 0.98^{11} \times E_{100}$$
- h) continue looping from 3(a)

Notes:

1. The values of these parameters need to be stored at each time increment, since reference to them in history is at times required (see note 7 for example)
2. These calculations differ from the steady state ones covered in (3) because of the need to maintain E_t between 0 and E₁₀₀, until the initial E_t and E₁₀₀ values are established. Refer to Figure 7(b) in main report.
3. Upward drift is characterised by Figure 8 in the main report.
4. A low voltage shut-down event (LVSD) will typically be characterised by the inverter load current (I_v) suddenly dropping to zero when the battery voltage is low.
5. A $\pm 5\%$ tolerance zone is established around 0% and 100% SoC, as suggested by Figure 8, 9, 10 and 11 in the main report. A different tolerance could be used; this provision simply reflects the fact that precise values for zero and full charge are elusive.
6. This third clause reflects the fact that an LVSD event can occur above zero charge level if there is a high sustained load. In this implementation of the algorithm a load of > 0.33 maximum load for a period of two or more minutes defines a high sustained load. Experience with a specific installation may lead to a refinement of these values.
7. Recalibration of C_{eff} under these conditions uses the ratio total energy out to the total energy in of the batteries over the previous 7 days from the current data point. The stored values for E_t, P_{out} and P_{in} from that 7 day history point are required for this calculation.
8. Downward drift is characterised by Figure 9 in the main report.
9. The E₁₀₀ too low situation is characterised by Figure 10 in the main report.
10. The E₁₀₀ too high situation is characterised by Figure 11 in the main report.
11. The E₁₀₀ too high check involves a daily reduction in the E₁₀₀ value until an E₁₀₀ too low event is triggered, as shown in Figure 11. This aging process is quite arbitrary, but a daily reduction (at midnight) of 2% produces results consistent with recalibration intervals of days rather than weeks.