

Enhancement of Steric Repulsion with Temperature in Oriented Lipid Multilayers

G. Pabst,¹ J. Katsaras,¹ and V. A. Raghunathan²

¹National Research Council, Steacie Institute for Molecular Sciences, Building 459, Station 18,
Chalk River, Ontario K0J 1J0, Canada

²Raman Research Institute, Bangalore 560 080, India
(Received 22 October 2001; published 6 March 2002)

We have studied the temperature dependence of the stacking periodicity, d , of oriented phospholipid multilayers using grazing angle neutron scattering techniques. d is found to increase substantially at higher temperatures, just before the bilayers peel off from the substrate. Although we do not observe thermal unbinding, our results are consistent with the notion that the unbinding transition is driven by steric repulsion arising from thermal fluctuations of the membranes, in contrast to those of a recent study by Vogel *et al.* [Phys. Rev. Lett. **84**, 390 (2000)].

DOI: 10.1103/PhysRevLett.88.128101

PACS numbers: 87.16.Dg, 61.10.Kw, 87.15.Ya

Many phospholipids self-assemble in water to form bilayers [1]. At temperatures above the so-called main transition temperature, the in-plane order in these systems is liquid-like. Such fluid bilayers have long served as models of biomembranes. In the case of nonionic lipids, van der Waals attraction and steric repulsion arising from thermal fluctuations of the membranes [2] are the only long-range interbilayer interactions. At relatively low temperatures, van der Waals attraction dominates over steric repulsion and the bilayers are in a bound state forming the L_α phase with a well-defined stacking periodicity, d . As the temperature is raised, fluctuations of the bilayers increase and at a sufficiently high temperature the steric repulsion force can overcome the attractive van der Waals force. The membrane stack can then be expected to unbind into individual bilayers dispersed in water, presumably in the form of unilamellar vesicles (ULVs).

The unbinding transition of a stack of membranes has been the subject of many theoretical investigations [3–6]. They predict this transition to be continuous. However, scaling arguments indicate that the temperature range over which the divergence in d can be seen is inversely proportional to the number of bilayers in the stack [6]. Therefore, in a typical experimental situation with hundreds of bilayers in the stack, the critical region is expected to be so narrow that the transition would appear discontinuous.

The first experimental observation of an unbinding transition was reported by Mutz and Helfrich [7]. Their phase contrast optical microscopy studies on digalactosyl-diacylglycerol (DGDG) multilamellar vesicles (MLVs) showed that the positional correlations of the bilayers in an MLV were lost on heating. More recently, Vogel *et al.* [8] reported x-ray reflectivity studies of oriented bilayer stacks made up of 1-palmitoyl-2-oleoyl-*sn*-glycero-3-phosphocholine (POPC) and 1,2-dimyristoyl-*sn*-glycero-3-phosphocholine (DMPC) as a function of temperature. Above a certain temperature, the scattered intensity from both systems was found to abruptly drop to that expected from a single bilayer adsorbed on the substrate. Vogel *et al.* associated this temperature with the unbinding transition.

Moreover, from the analysis of the diffuse scattering, they were able to estimate the moduli of compression (B) and curvature (K) of the bilayer stack. In the case of POPC, they found B to decrease by an order of magnitude and K to decrease by about 30% as the temperature was varied from 10 to 80 °C. However, since they did not observe an increase in d , expected from such a decrease in the elastic moduli, they concluded that steric repulsion was not responsible for the unbinding.

In order to reconcile the reduction in the elastic moduli with the absence of swelling, Vogel *et al.* [8] invoked the possibility that the compressibility modulus B is determined, at least partly, by parameters such as the static defect density in the system. The speculative nature of their conclusions, and the fact that swelling of bilayers with increasing temperature has been previously reported in un-oriented samples [9,10], prompted us to carry out detailed neutron diffraction experiments on both oriented and powder samples of POPC and DMPC.

One of the clear advantages in using neutrons, compared to x-rays, is that we are not limited by the volume of water that can be used to hydrate the sample, as both the sample cell and the substrate are transparent to neutrons. Further, the size of the incident neutron beam is much larger, so that the entire sample, of the order of a few cm² in area, contributes to the scattered intensity. We find that the stacking periodicity d of both systems studied shows a significant increase at high temperatures. Since the only long-range repulsive interbilayer interaction in these systems is of steric origin, this increase in d must result from increased bilayer flexibility. The observed enhancement of steric repulsion at high temperatures supports the conjecture that thermal unbinding of the membrane stack is driven by steric repulsion, contrary to the conclusion of Vogel *et al.* [8]. We also find that oriented bilayers are not suitable for studying the unbinding transition due to the continuous peeling off of bilayers from the stack.

POPC and DMPC were obtained from Avanti Polar Lipids (Birmingham, Alabama) and were used without further purification. Polyvinylpyrrolidone (PVP) of average

molecular weight 40000 was purchased from Sigma Chemical Co. (Milwaukee, Wisconsin) and D_2O of 99.92 wt % purity from Atomic Energy of Canada Limited (Chalk River, Ontario). The oriented samples were prepared by first spreading a solution of typically 20 mg lipid in methanol on a clean substrate. Both silicon and mica substrates ($48 \text{ mm} \times 18 \text{ mm} \times 0.3 \text{ mm}$) were used in the present experiments. After the evaporation of the solvent, the samples were kept in vacuum for 12–24 h to remove any traces of methanol. The lipid films were subsequently annealed for 12–24 h at 70°C in a D_2O saturated environment. For the scattering experiments, the substrate was mounted in an aluminum cell containing D_2O (Fig. 1). The entire aligned sample was covered by a 6.5 mm thick water layer, thus ensuring full hydration. We have also studied an unoriented sample made up of POPC MLVs (20 wt %) in order to compare the results with those obtained from oriented samples [11]. The experiments were carried out at the NRU reactor, Chalk River Laboratories, using the N5 triple-axis spectrometer, which has a flux of about $5.4 \times 10^9 \text{ neutrons cm}^{-2} \text{ s}^{-1}$ at the monochromator. Neutrons of wavelength 2.37 \AA were selected using either the (002) reflection of a pyrolytic-graphite monochromator or the (113) reflection of a germanium monochromator. The beam size at the

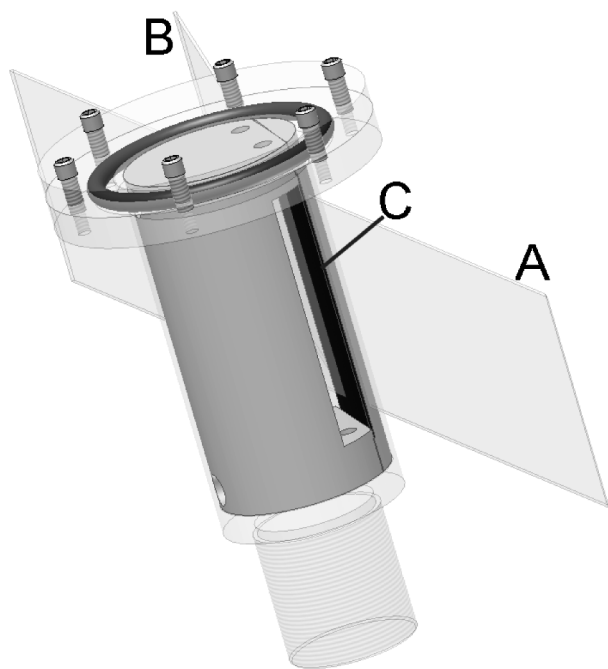

FIG. 1. Schematic of the sample cell used to study oriented multibilayers. The incident neutron beam (A) is scattered along (B) by the oriented multilayers on the substrate (C). The substrate faces a 6.5 mm wide cavity containing D_2O . The cell is mounted in an aluminum chamber (not shown) whose temperature is regulated using a circulating thermostat to within $\pm 0.1^\circ\text{C}$. Absorption of neutrons by the aluminum walls of the chamber and the substrate is negligible. The sample cell is sealed to prevent evaporative loss of D_2O .

sample was about $50 \text{ mm} \times 6 \text{ mm}$. The d of one of the oriented samples was monitored over time after filling the sample cell with D_2O . The time taken for the sample to achieve full hydration (i.e., maximal d) was found to be of the order of 10 h. Thus, all the samples were initially equilibrated for about 10 h before starting the measurements. For each subsequent change in temperature, the sample was equilibrated for 30 min.

The observed variation of d with temperature in POPC multibilayers is given in Fig. 2. This figure shows data from three different samples; two on silicon substrates and the third on mica. Clearly, all the samples exhibit the same behavior. The last point in each data set corresponds to the highest accessible temperature, beyond which the diffraction signal was lost. In the oriented sample of POPC studied by Vogel *et al.* [8], the signal was lost at about 80°C . The fact that we are able to go to much higher temperatures points to the possibility that the loss of signal in their experiments was not due to the thermal unbinding of the membrane stack. The initial decrease in d with temperature has been the subject of many recent studies [9,12], and is believed to be the result of both the thinning of the bilayer and the water layer. Our data on highly aligned DMPC samples also show the same trend (data not shown). The observed increase in d at higher temperatures is similar to that found in DMPC MLVs [9]. These results are very different from those of Vogel *et al.* [8], who observe a monotonic increase in d of about 1 \AA as the temperature was varied from 10 to 80°C . As both POPC and DMPC are zwitterionic, the only long-range repulsive interbilayer interaction present is steric repulsion. The increase in d at high temperatures, therefore, indicates a reduction in the rigidity modulus $\kappa (= Kd)$ of the bilayers, leading to more pronounced thermal fluctuations and resulting in a stronger steric repulsion between the bilayers.

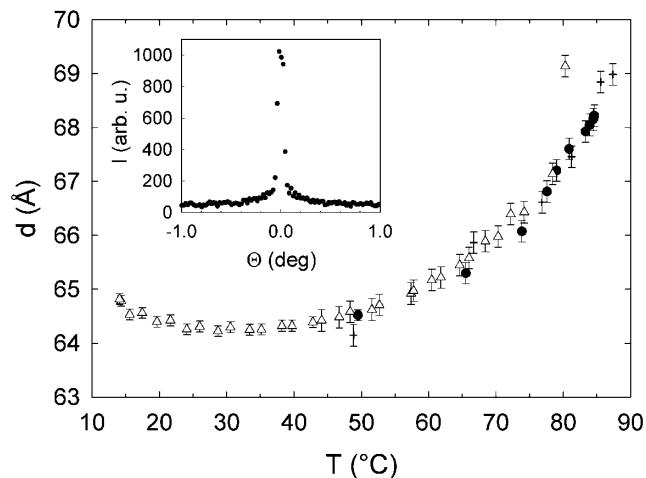

FIG. 2. The variation of the lamellar periodicity of POPC with temperature. The data were obtained from samples aligned on silicon (Δ , $+$) and on mica (\bullet) substrates. A typical rocking curve is also shown (inset, $\text{FWHM} = 0.08^\circ$).

In order to estimate the temperature dependence of the bulk modulus for compression B , we have measured d as a function of temperature in POPC under an osmotic pressure P , which was applied by keeping the bilayer stack in contact with a PVP solution in D_2O . The results are shown in Fig. 3. The application of an osmotic pressure leads to a larger decrease in d at higher temperatures, compared to the nonstressed system at $P = 0$, indicating a decrease in the compressibility modulus B with temperature. Figure 3 also shows that the temperature at which the Bragg peak disappears increases with P . This dependence of d on P implies roughly a 50% decrease in B across the temperature range studied [13]. Note that the decrease of K and B with increasing temperature observed by us is similar to the trend reported by Vogel *et al.* [8], though our rough estimate of the change in B is, in comparison, much lower. However, the important point to note is that, in all of our samples, regardless of the type of substrate or lipid used, we observe a significant swelling of the bilayers at high temperatures consistent with the reduction in the elastic moduli, whereas Vogel *et al.* do not. It was this lack of swelling that led them to conclude that thermal unbinding of the membrane stack is not driven by steric repulsion. The fact that they obtained a lower unbinding transition temperature for POPC (80 °C) compared to DMPC (95 °C), even though κ of POPC bilayers is larger by almost a factor of 2 [14], seemed to support this conclusion. However, as will be discussed below, one has to be careful in attributing the sudden disappearance of the Bragg peak to the unbinding transition.

In some of our samples, we found abrupt drops in the intensity of the quasi-Bragg peak as the temperature was raised. In different samples it occurred to different degrees and at different temperatures. Even at a fixed tem-

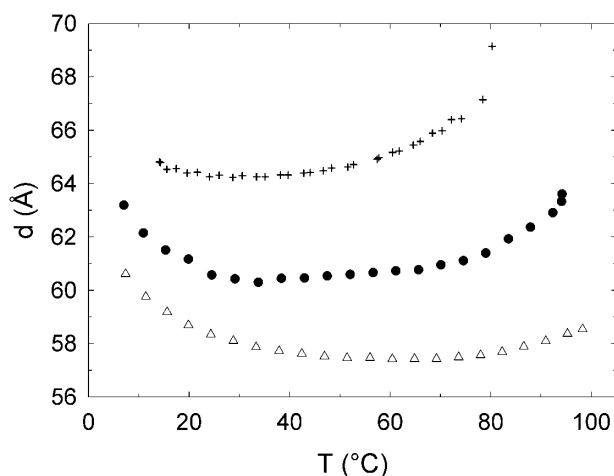

FIG. 3. The variation of the lamellar periodicity of POPC with temperature under osmotic pressure, P . The three curves correspond to $P = 0$ (+), 0.4 atm (•), and 2.2 atm (Δ), respectively. B was estimated from $\partial P/\partial d$ using the data at $P = 0$ and $P = 0.4$ atm.

perature, the intensity was found to decrease with time. A typical plot is shown in Fig. 4. There is a continuous decrease in the intensity with time. The rate of decrease is found to be larger at higher temperatures. This decrease in the scattered intensity is undoubtedly due to a gradual loss of sample from the substrate into water. However, it is not clear if the layers are peeling off one by one or in bunches. The fact that the scattered intensity often decreased abruptly by significant amounts points to the possibility that at least in some cases bunches of bilayers get dislodged from the substrate. A similar behavior has been reported by Hartung *et al.* [15] in POPC. They also found a gradual decay of the scattered intensity with time at a fixed temperature of 25 °C, with the decay rate varying significantly from sample to sample. The patches of the sample dislodged from the substrate can be expected to form MLVs (and ULVs in the case of free bilayers) in the water surrounding the sample. The contribution of these MLVs to the intensity of the Bragg peak would be negligible as they make up an unoriented sample of extremely low concentration [16]. Therefore, if the entire scattering volume of the sample were to get detached from the substrate, the diffraction peak would abruptly disappear. It is impossible to differentiate this situation from a true unbinding transition, if the latter is as sharp as predicted. The problem of the sample dislodging from the substrate is accentuated when using a fine beam, as in the case of x-ray reflectivity studies.

In order to further confirm the importance of sample loss, we have studied a thin oriented sample made with 1 mg of lipid, instead of the typical 20 mg. The values of d obtained from this sample are again similar to those obtained from thicker ones. However, the Bragg peak disappeared at around 50 °C in this case (data not shown). Thus, it is clear that the disappearance of the peak does not necessarily indicate the onset of the unbinding transition,

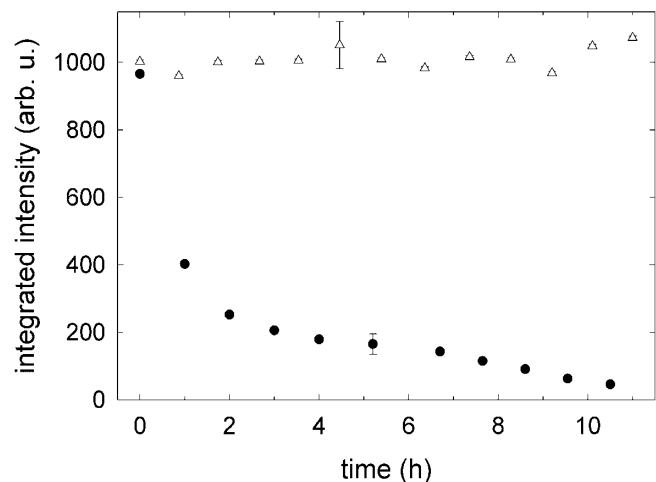

FIG. 4. The temporal dependence of the integrated intensity of the first quasi-Bragg peak obtained from oriented sample at 78 °C (•) and from MLV sample at 84 °C (Δ).

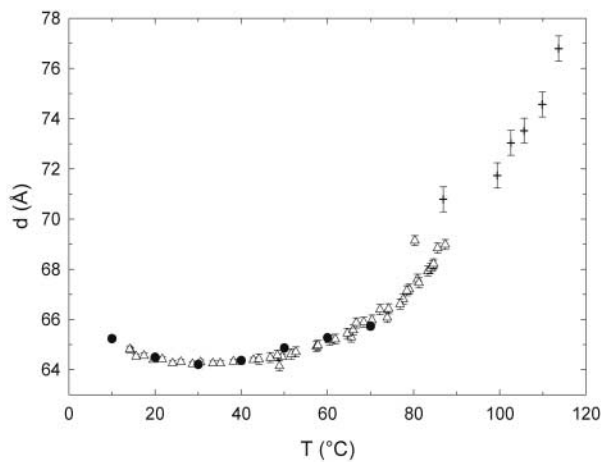

FIG. 5. The variation of the lamellar periodicity of POPC MLVs with temperature (+). Data from oriented samples (Δ) are also presented for comparison. The \bullet 's correspond to data from MLVs obtained using x-rays [10]. In the case of MLVs, the larger error bars are the result of asymmetric quasi-Bragg peaks, due to the superposition of Debye-Scherrer rings from a line source of neutrons, and poorer signal/noise. The instrumental resolution was the same for both MLV and aligned samples.

but also arises from the detachment of the sample from the substrate. On the other hand, in the case of an unoriented sample consisting of MLVs, the decrease in the scattered intensity results either from the formation of ULVs or from the loss of positional correlations of the bilayers within the MLVs. Hence, in this case, the disappearance of the Bragg peak is a true signature of the unbinding transition.

In Fig. 4 we show the results from an unoriented sample consisting of POPC MLVs, containing 20 wt % of the lipid. The integrated intensity of the Bragg peak, at a fixed temperature, did not show any significant decay with time. Moreover, there was also no apparent decay of the intensity with temperature, implying that almost all the bilayers were still in the bound state even up to a temperature of 115 °C. The temperature dependence of d obtained is shown in Fig. 5. In comparison to oriented samples, we are able to go to higher temperatures (as high as permitted by our setup) and, hence, see a larger increase in d , consistent with the trend exhibited by the aligned samples (Fig. 2). This result then further confirms that the abrupt drop in the scattered intensity seen in oriented samples is not the result of an unbinding transition, but is due to the dislodging of patches of the sample from the substrate. It is very likely that a similar loss of sample occurred in the systems studied by Vogel *et al.* [8]. In fact, Fig. 5 of [8] shows a small peak at $q \approx 0.1 \text{ \AA}^{-1}$, which is not accounted for by the scattering from a single bilayer on the substrate. This points to the presence of a thin stack on the substrate, consisting of a few bilayers. Therefore, in all probability, the

sudden drop in the scattered intensity observed by Vogel *et al.* was not the result of an unbinding transition.

The swelling of bilayers at higher temperatures, reported here, should not be confused with the divergence of the d spacing at the unbinding transition. The observed swelling is consistent with the decrease in the rigidity modulus κ of the bilayers with increasing temperature. Such swelling is not predicted by the theories as they do not take into account the temperature dependence of κ . Although we do not observe the unbinding transition, the enhancement of thermal fluctuations of the membranes, seen at high temperatures, supports the notion that it is driven by steric repulsion. We also find that oriented samples are not well suited for probing this transition. In view of our results, earlier reports of experimental observation of thermal unbinding of oriented membrane stacks have to be reexamined.

We thank Mike Watson for technical assistance. G.P. is grateful to the Austrian Science Fund (Grant No. J2004-GEN).

- [1] See, for example, *Structure and Dynamics of Membranes*, edited by R. Lipowsky and E. Sackmann, Handbook of Biological Physics (Elsevier, Amsterdam, 1995).
- [2] W. Helfrich, *Z. Naturforsch.* **33A**, 305 (1978).
- [3] R. Lipowsky and S. Leibler, *Phys. Rev. Lett.* **56**, 2541 (1986).
- [4] R. Netz and R. Lipowsky, *Phys. Rev. Lett.* **71**, 3596 (1993).
- [5] S. T. Milner and D. Roux, *J. Phys. I (France)* **2**, 1741 (1992); W. Helfrich, *J. Phys. II (France)* **3**, 385 (1993).
- [6] R. Lipowsky, *Z. Phys. B* **97**, 193 (1995).
- [7] M. Mutz and W. Helfrich, *Phys. Rev. Lett.* **62**, 2881 (1989).
- [8] M. Vogel, C. Münster, W. Fenzl, and T. Salditt, *Phys. Rev. Lett.* **84**, 390 (2000).
- [9] S. Kirchner and G. Ceve, *Europhys. Lett.* **23**, 229 (1993).
- [10] G. Pabst *et al.*, *Langmuir* **16**, 8994 (2000).
- [11] Previously, it has been shown that samples aligned on a substrate are, with regards to repeat spacings, transition temperatures, etc., indistinguishable from their liposomal counterparts [J. Katsaras, *Biophys. J.* **73**, 2924 (1997); **75**, 2157 (1998).]
- [12] T. Hønger *et al.*, *Phys. Rev. Lett.* **72**, 3911 (1994); R. Zhang *et al.*, *Phys. Rev. Lett.* **74**, 2832 (1995); J. Lemmich *et al.*, *Phys. Rev. Lett.* **75**, 3958 (1995); F. Y. Chen *et al.*, *Phys. Rev. Lett.* **79**, 4026 (1997); J. F. Nagle *et al.*, *Phys. Rev. E* **58**, 7769 (1998); P. C. Mason *et al.*, *Phys. Rev. E* **63**, 030902(R) (2001).
- [13] This is only a lower estimate for the decrease in B , as the osmotic pressure of a PVP solution decreases with temperature [H. Vink, *Eur. Polym. J.* **7**, 1411 (1971)].
- [14] W. Rawicz *et al.*, *Biophys. J.* **79**, 328 (2000).
- [15] J. Hartung, W. Helfrich, and B. Klösgen, *Biophys. Chem.* **49**, 77 (1994).
- [16] Even if the entire sample dissolved in the surrounding water, the wt % of lipid would amount only to about 0.05%.