

# EFFECT OF ELECTRIC FIELD ON TYNDALL SCATTERING

BY R. S. SUBRAHMANYA, K. S. GURURAJA DOSS AND  
BASRUR SANJIVA RAO

(From the Department of Chemistry, Mysore University, Central College, Bangalore)

Received November 18, 1943

## *Introduction*

AMONGST the agencies which can bring about a preferential orientation of particles in a mobile colloidal system having anisotropic particles are (a) its flow, (b) the magnetic field, and (c) the electric field. The existence of such orientation has been proved by the work of earlier investigators on double refraction, induced by these agencies.<sup>1</sup> The effect of the preferential orientation on the intensity of Tyndall scattering is of great interest. The only investigations which have been carried out in this field are by (a) Freundlich<sup>2</sup> on the changes in Tyndall intensity, induced by flow and (b) R. S. Krishnan<sup>3</sup> on the effect of magnetic field on the Tyndall intensity. The effect of the electric field however, has so far received little attention. Mueller<sup>4</sup> attempted to study this effect with bentonite sols, but did not get any positive results. This is probably due to the fact that the particles in the sols used by Mueller were very fine and the orientation was not sufficiently intense to show the effect, owing to the lively Brownian movement of the fine particles. The small intensity of the scattered light might have added to the difficulty in observing the effect. The present investigation was undertaken with a view to study the effect of the electric field on a few typical sols.

## *Experimental*

1. *Preparation of silver iodide sol.*—Silver iodide sol was prepared by the method of Kruyt and Verwey.<sup>5</sup> Silver nitrate was run dropwise into a solution of potassium iodide containing a 10% excess of the latter. The concentrations of potassium iodide solution and silver nitrate solution were so adjusted that the resulting sol contained about 40 millimols of AgI/litre. The sol was then subjected to hot dialysis, until the dialysate gave no test for iodide (14 hrs.). By this method a highly purified sol stabilised by iodide ions and having H<sup>+</sup> as gegen ions was got. It was found advantageous to further stabilize the sol by addition of potassium iodide to give a concentration of 0.001 N iodide ion. The sol was then centrifuged (1800 r.p.m.) for one and a half hours to remove the bigger particles. The clear sol was decanted out. The sol prepared in this way was stable for many months.

2. *Preparation of stearic acid sol.*—Stearic acid sol was prepared by Mukherjee's method.<sup>6</sup> 2.5 gm. of "extra pure" stearic acid was dissolved in 200 c.c. of methyl alcohol. The alcoholic solution was poured dropwise into 700 c.c. of boiling distilled water. Then the excess of methyl alcohol was boiled off. The sol was then filtered through Whatman No. 3 filter-paper, in order to free it from the larger particles. It was then protected by using 0.0003 N sodium hydroxide. The sol prepared by this method was stable for many months.

3. *Sol of Benzopurpurine 6 B.*—A five-year old sol of benzopurpurine (0.0002 M) prepared by Doss<sup>7</sup> was used.

4. *Determination of size of the particles.*—The size of the particles in these sols was determined with the aid of the slit-ultramicroscope (Bausch and Lomb). The field of view in the ultramicroscope was limited by using an Ehrlich stop. The dimensions of the Ehrlich stop were determined by means of an eye-piece micrometer, previously calibrated using a stage micrometer. A concentrated sol was put into the cell, provided for the purpose. The slit was turned to the vertical position and the width of the beam as seen in the ultramicroscope was suitably adjusted, by rotating the screw head. This gave the depth of illumination, for the horizontal position of the slit. Then the slit was rotated to the horizontal direction. The volume of the illuminated portion of the sol = Length of the Ehrlich stop × Breadth of the Ehrlich stop × depth of illumination.

The illuminated zone was 0.1 cm. below the surface of the liquid in the cell. The Perrin distribution of micelles did not therefore interfere with the measurements.

The sol was diluted sufficiently so as to give an easily countable number of particles in the small illuminated element of volume. The number of particles  $N$ , in the element of volume, was counted every two seconds. About three hundred readings for  $N$  were taken. One of the typical sets obtained is given in Table I.

TABLE I

2	2	2	2	2	2	2	2	2	2	2	0	0	0	0	2	2	1	2	2	2	3	3	3
2	3	1	2	3	4	4	2	3	3	4	1	3	4	3	3	2	1	2	0	1	2	2	
0	0	0	0	0	0	0	0	0	0	0	0	0	0	2	0	0	1	2	4	3	4	5	
2	2	1	4	1	2	3	3	3	4	4	3	1	2	3	2	1	1	1	1	0	0	0	
0	1	1	2	1	1	1	0	0	0	0	1	2	2	1	3	2	3	1	1	2	2		
2	2	1	1	2	1	2	1	1	1	2	1	1	1	1	1	0	2	1	2	1	0	2	1
2	2	3	3	3	2	4	1	1	1	2	3	3	4	4	5	0	0	1	3	3	0	1	2

The average of the values was 1.66.

With a view to find out whether the values really correspond to the spontaneous concentration fluctuations, V. Smoluchowski's relations<sup>8</sup> for (a) the mean relative fluctuation  $\delta$ , (b) the mean square relative fluctuation  $\delta^2$  and (c) the probability  $P(n)$  for the occurrence of any particular  $N$  were verified. Results are given in Tables II and III.

TABLE II

$\bar{\delta}_{\text{obs.}}$	$\bar{\delta}_{\text{calc.}} = 2e^{-\nu} \nu k / k!$	$\bar{\delta}^2_{\text{obs.}}$	$\bar{\delta}^2_{\text{calc.}} = \frac{1}{\nu}$
0.66	0.63	0.56	0.60

TABLE III

	$n = 0$	$n = 1$	$n = 2$	$n = 3$	$n = 4$	$n = 5$
$P(n)_{\text{calc.}} = \frac{e^{-\nu} \cdot \nu^n}{n!}$	31.2	51.77	42.95	23.75	9.85	3.27
$P(n)_{\text{obs.}}$	35.0	41.00	46.00	25.00	12.00	2.0

These results (Tables II and III) show that the values for the spontaneous concentration fluctuations obey the Smoluchowski's equations.

The results obtained for the concentration and particle size are given below [Table III (a)]:—

TABLE III (a)

Sol.	Conc. of sol.	Dilution (to give a countable no. of particles)	No. of particles per c.c. of conc. sol.	Equivalent spherical diameter
Silver iodide sol. .. ..	0.25%	1 : 200,000	$7.32 \times 10^{11}$	104.8 $m\mu$
Stearic acid sol. .. ..	0.085%	1 : 10,000	$3.2 \times 10^{10}$	390.8 $m\mu$

Size of the particles in benzopurpurine 6 B sols however, could not be determined, since (a) the sols had, as was to be expected, particles of largely varying sizes and (b) the bigger particles broke down on dilution into particles of smaller size.

5. *Shape of the particles.*—Stearic acid sol at temperatures below the melting point has been shown to consist of anisotropic particles by Schlierung experiments.<sup>9</sup> The particles also exhibit in a striking manner the twinkling effect under the ultramicroscope. The sol also exhibits electric double refraction. The quantitative measurement of the double

refraction is difficult since the large scattering in the forward direction interferes with the measurement. These effects disappear when the sol is heated to about 70° C. (a temperature which is higher than the melting point of stearic acid), showing thereby that the observed effects are connected with the anisotropic shape of the particles. In order to find out if the particles are to be considered as rods or discs, the elegant new technique of Langmuir<sup>10</sup> was adopted. In this technique the sol is allowed to flow through a pipette. The stem of the pipette is illuminated by a beam of light polarised at 45° to the direction of flow. The light transmitted by the stem (in which the flow is occurring) is viewed through another polaroid which is crossed with reference to the former polaroid. If the sol consists of rods, the flow of the sol produces a uniform brightening throughout the thickness of the stem of the pipette. If the sol contains discs, a flowing sol shows a central dark band. We have confirmed the observation of Langmuir that vanadium pentoxide shows a uniform brightening. With stearic acid sols a clear dark band is noticed, showing that it contains disc-shaped particles.

Silver iodide sol did not show any schlierung. Under the ultramicroscope, the twinkling was not marked. The Langmuir technique showed that the particles were not appreciably anisometric.

The aged benzopurpurine sol showed marked schlierung. The Langmuir technique with a concentrated sol indicated that the particles were rod-shaped.

6. *Technique for investigating the effect of electric field on Tyndall scattering.*—The electric field was applied by employing platinum or carbon sheet electrodes having apertures in them so as to allow the incident or scattered beam to pass. The light was incident on the sol horizontally. The scattered light was viewed transversely in the vertical and in the horizontal directions. It can be shown that one of the directions of observation can be dispensed with since each of the cases in the vertical direction of observation has a completely corresponding position in the horizontal direction of observation. This fact was also confirmed experimentally. Only the results got with the horizontal direction of observation have been given in Table IV. The field could be applied (*a*) longitudinally parallel to the beam ( $E_z$ ) or transversely in the vertical ( $E_y$ ) or horizontal ( $E_x$ ) directions. These gave six modes of observation. The incident light was polarised horizontally or vertically by using a polaroid. The scattered light was viewed through a polaroid so as to enable us to notice the changes in the intensity of the scattered component, parallel or perpendicular to the direction of the incident

beam. The results are represented in Table IV. The fields used were of the order of 100 volts/cm. D.C. or 220 volts/cm. A.C. Both the types of fields gave identical results. With direct current, however, electrolysis often interfered with the work.

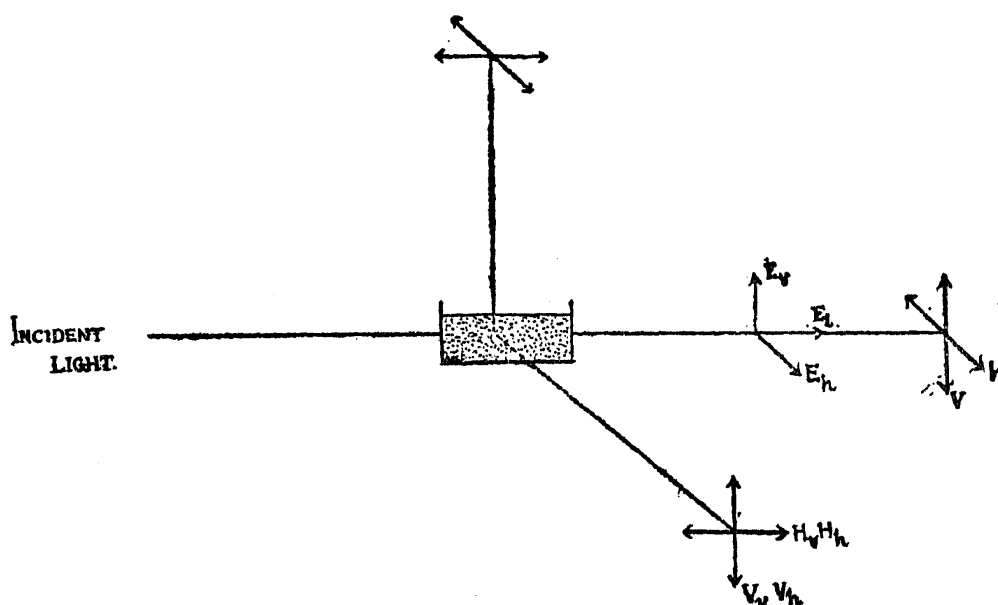

FIG. 1

The various symbols used in Table IV are illustrated in Fig. 1.

TABLE IV

*Effect of electric field on Tyndall scattering by stearic acid sol*

- ++ indicates strong brightening on applying the field
- + indicates moderate brightening on applying the field
- indicates darkening on applying the field

Field	Corresponding Orientation	Effect of the field			
		$V_v$	$H_v$	$V_h$	$H_h$
$E_v$		++	+	+	++
$E_l$		-	-	-	-
$E_h$		-	-	-	-

The results obtained with benzopurpurine sol were identical with those got with the stearic acid sol. With silver iodide sol, the effects were not observable at the low fields used.

*Discussion*

Freundlich<sup>11</sup> has proposed a theory to account for the effect of flow on Tyndall scattering which can be applied *mutatis mutandis* to the action of the electric field. He assumes that the scattered intensity is determined by the orientation of the particle in relation to the direction of the incident electric vector. His predictions, no doubt, apply only to positively double refracting rod-shaped particles. This theory however can be extended to apply even to negatively double refracting disc-shaped particles and leads to the result that the scattering intensity will similarly be affected by the electric field in any of the transverse directions. But this conclusion is not at all in accord with our observations. Furthermore, since the scattering intensity is assumed to be dependent on the direction of the incident vector, the effect of field should differ according as the incident vector is horizontal or vertical. This too is not supported by our experimental results. The Freundlich theory therefore breaks down completely.

The applicability of the Rayleigh theory of scattering to the present case may now be considered. The electric field itself tends to orient the particles so as to make their longest axis parallel to the field. We shall discuss how this orientation affects the various scattered components. (In the present discussion we shall assume that the particles are discs.)

*The component  $V_v$ .*—The change in the intensity of  $V_v$  can be calculated by finding out the change in the average polarisability of the particle in the vertical direction brought about by the orientating influence of the field. Let the three principal polarisabilities of the disc-shaped particle be  $a$ ,  $a$  and  $b$  ( $b \ll a$ ). The average polarisability for the present purposes can be calculated by taking the mean of the values for the extreme orientations of the particle. This comes out to be:

$$\frac{a + \frac{a+b}{2} + \frac{a+b}{2}}{3} = \frac{2a+b}{3}.$$

Particles oriented by  $E_v$  would have the various orientations given in Table IV. The average polarisability in the vertical direction corresponding to this orientation would be  $a$ . Since  $a$  is greater than  $\frac{2a+b}{3}$ , one should get a brightening in this case. For particles oriented by  $E_l$  and  $E_h$ , the average polarisability would be  $\frac{a+b}{2}$ . Since  $\frac{a+b}{2}$  is smaller than  $\frac{2a+b}{3}$ , there would be a darkening in these cases.

The component  $H_v$ .—Let the incident light be parallel to the X-axis, the horizontal direction of observation be along Y-axis and let the third axis be the Z-axis. In predicting the action of the electric field we shall consider the three main types of orientation:—

- (a) The plane of the discs  $\parallel$  to the X-axis.
- (b) The plane of the discs  $\parallel$  to the Y-axis.
- (c) The plane of the discs  $\parallel$  to the Z-axis.

In the absence of the field all the three orientations are equally probable. Of these, the orientations corresponding to (b) are the only ones which give rise to the component  $H_v$ . This type of orientation is favoured by  $E_h$  and disfavoured by  $E_v$  and  $E_l$ . Thus there should be a brightening produced by  $E_h$  and darkening by  $E_v$  and  $E_l$ .

The component  $V_h$ .—This component is got only by the orientation (a). Since  $E_l$  favours this orientation and the other two fields disfavour it, we should expect a brightening with  $E_l$  and darkening with  $E_h$  and  $E_v$ .

The component  $H_h$ .—This component is got only by the orientation (c). Since  $E_v$  favours this orientation and the other two disfavour it, we should expect a brightening with  $E_v$  and darkening with  $E_h$  and  $E_l$ .

The above predictions are summarised in Table V.

TABLE V

*Predictions on the basis of the Rayleigh Theory*

Field	$V_v$	$H_v$	$V_h$	$H_h$
$E_v$	+	—	—	+
$E_l$	—	—	+	—
$E_h$	—	+	—	—

A comparison of Tables IV and V shows that the Rayleigh theory is not applicable to the present case.\* This is not very surprising. For, the stearic acid sol used in the present work consists of particles which are too large for the Rayleigh theory to hold good. This is supported by the fact that this sol shows a marked Krishnan effect, the  $\rho_h$  deviating appreciably from 100%.<sup>12</sup> Moreover, the scattering is highly asymmetric there being a large scattering in the forward direction and the Tyndall light has hardly any preponderance of the blue tint. A rigorous theoretical treatment of

\* We have assumed that the particles are disc-shaped. Assuming any other shape does not remove the difficulty.

systems such as this, composed of large and anisotropic particles is beset with many difficulties. Under these circumstances, we would formulate an empirical generalisation, which we would refer to as "The Reflection Rule", which summarises all the facts observed in such systems:—

"Large disc-shaped or rod-like particles oriented by a linear field, show enhanced scattering when the field is put on, if the plane of incidence and observation is perpendicular to the field; in other orientations the scattering is decreased by the field."

We may also add that the brightening when it occurs, is more marked with  $V_v$  and  $H_h$  than  $H_v$  and  $V_h$ .

It was also found that in the brightening positions the  $H_v$  or  $V_h$  had a distinct red tinge whereas the  $V_v$  and  $H_h$  had a distinct blue colour. This interesting observation remains to be elucidated.

It is interesting to note that benzopurpurine sol gave the same general results as given in Table I, though this sol consists of rod-shaped particles as shown by the Langmuir technique. We would also like to record the observation that the benzopurpurine sol treated with small amounts of sodium hexa-metaphosphate showed (a) diminished scattering and (b) no schlierung, and did not show any change in Tyndall scattering when an electric field was applied. This was presumably due to the dispersion caused by sodium hexa-metaphosphate. The exact mechanism of the action of the latter is not clear.

An attempt was made to make similar observations on the effect of flow on Tyndall scattering. Stearic acid sol was allowed to flow in a tube of circular cross-section. The observations were confined to the middle of the tube. A comparison of these observations with those obtained with the electric field, showed that an electric field is equivalent to a flow in a tube (of circular section) in the direction of the field. This is in agreement with the orientation of particles postulated by Langmuir.<sup>10</sup>

It is to be noted that the observations made by R. S. Krishnan<sup>8</sup> on graphite sols, using magnetic fields can mostly be interpreted in terms of the Reflection rules formulated in the present paper.

### Conclusion

The study of the action of an electric field on the scattering intensity of sols has thus led to interesting results. The study is useful in determining the shape of the particles. The present technique would be supplementary to the studies of double refraction, in that the latter cannot be conveniently



investigated in a highly scattering system. With slightly conducting sols, large fields can be used so as to produce saturation effects. Under such conditions, the use of rotating fields would bring about a unique orientation of the discs. A superposition of two A.C. fields of different cycles at right angles to each other would have the same effect as the circular field. The use of elliptical fields would reveal any want of equality of the two axes in the plane of discs of flat particles. The technique itself is simpler than the flow technique. Since there is often a large difference in the dielectric constant between the particles and the medium, the orientation is marked even with small fields, and the electric field is thus more powerful than the magnetic field in bringing about orientation.

*Acknowledgement*

The authors are deeply grateful to Sir C. V. Raman for his kind and instructive discussions.

REFERENCES

1. Taylor .. *Treatise on Physical Chemistry*, Second Edition, Vol. II, 1608.
2. Freundlich .. *Colloid and Capillary Chemistry*, 1926, 407.
3. R. S. Krishnan .. *Proc. Ind. Acad. Sci.*, 1938, 7 A, 91-7.
4. Mueller .. *Phys. Rev.*, 1939, 55, 508.
5. Kruyt and Verwey .. *Inor. Colloid Chem. Weiser*, Vol. III, 115.
6. .. *Jour. Mys. Univ.*, 1935, 49, 84.
7. Doss .. *Kolloid-z.*, 1938, 84, 138.
8. Taylor .. *Treatise on Physical Chemistry*, Vol. II, 1577-8.
9. Subbaramiah, Iyer and Doss .. *Current Science*, 1939, 8, 360.
10. Langmuir .. *J. Chem. Phys.*, 1938, 6, 873.
11. Freundlich .. *Colloid and Capillary Chemistry*, 1926, 403-411.
12. Subrahmanya, Doss and Rao (Unpublished).