

[Home](#) [Search](#) [Collections](#) [Journals](#) [About](#) [Contact us](#) [My IOPscience](#)

Single and multiple ionization of CS_2 in intense laser fields: wavelength dependence and energetics

This article has been downloaded from IOPscience. Please scroll down to see the full text article.

1996 J. Phys. B: At. Mol. Opt. Phys. 29 3135

(<http://iopscience.iop.org/0953-4075/29/14/023>)

View [the table of contents for this issue](#), or go to the [journal homepage](#) for more

Download details:

IP Address: 122.179.17.200

The article was downloaded on 22/10/2010 at 06:30

Please note that [terms and conditions apply](#).

Single and multiple ionization of CS₂ in intense laser fields: wavelength dependence and energetics

C P Safvan, V R Bhardwaj, G Ravindra Kumar, D Mathur and F A Rajgara
Tata Institute of Fundamental Research, Homi Bhabha Road, Bombay 400 005, India

Received 24 April 1996

Abstract. Single and multiple ionization of carbon disulphide by intense picosecond laser fields is the subject of this paper. Mass spectra were measured at five wavelengths from the infrared to the ultraviolet. In terms of the Keldysh adiabaticity parameter, we cover both the multiphoton and the tunnelling regimes. The dynamics of the dissociative ionization process is shown to be dependent upon the regime in which the laser–molecule interaction occurs. Resonances, which may be possible and which could access electronically excited states of the molecule, appear to play little part in the dynamics. Ion abundances have been measured as a function of laser intensity in the tunnelling regime; no correlation is found between measured values of saturation intensity and zero-field molecular properties such as dissociation or ionization thresholds and ionization energies. In addition, the covariance mapping technique is applied to study the dissociation dynamics of multiply charged ions at 1064 nm. The measured values of kinetic energy release accompanying formation of fragment ion-pairs are very much less than those measured in single-photon and electron-impact experiments. It is postulated that this reduction may be a manifestation of the extent to which potential energy surfaces of CS₂^{q+} ions are ‘flattened’ by the action of the intense, linearly polarized laser radiation, akin to the bond-softening process that has been observed in the case of diatomic molecules. Our observations indicate that distortion of molecular potential energy surfaces may be the dominating feature in intense laser–molecule interactions.

1. Introduction

Studies of the ionization and dissociation of molecules in intense laser fields continue to be the focus of considerable contemporary interest (see, for instance, Bandrauk 1994, Codling and Frasinski 1993, Corkum and Dietrich 1993, Guisti-Suzor *et al* 1995, Ilkov *et al* 1995, Kumar *et al* 1996a, b and references therein). The effects on molecules of the electric field present in intense light fields give rise to several phenomena which have major consequences for the dynamics of molecular dissociation and ionization:

(1) Zero-field potential energy surfaces of molecules can be grossly distorted (see, for instance, the recent review by Guisti-Suzor *et al* 1995), giving rise to possibilities of bond softening or bond hardening which, in turn, may result in totally different energetics accompanying the dissociation/dissociative ionization process.

(2) The molecular ground state can be strongly coupled to high-lying excited states, or to the continuum, by multiphoton excitation, giving rise to the possible dependence of molecular fragmentation patterns on the wavelength of the exciting laser light.

(3) The electric field generated by the intense laser light is sufficiently strong to cause both ionization and dissociation, and the competition between these two processes

may depend not only upon zero-field molecular structure properties (dissociation energies, ionization energies) but also upon properties of the laser field itself (Kumar *et al* 1994a, b).

(4) The polarized light field can *align* linear molecules, so that the fragment ions resulting from the dissociation process possess markedly anisotropic angular distributions (Normand *et al* 1992, Dietrich *et al* 1993, Kumar *et al* 1996a, b).

We present here the results of measurements of the dissociative ionization patterns of a linear triatomic, CS₂, over a range of incident laser wavelengths, covering the region from the infrared to the ultraviolet: 1064, 683, 590 and 355 nm. We also make a preliminary foray into the hitherto-unexplored question of the possible role of resonances in molecular dissociative ionization in strong laser fields. Specifically, our measurements have been conducted with the following aims:

(i) extending our earlier measurements conducted at 532 nm (Kumar *et al* 1994a, b); specifically, we now study the dissociative ionization pattern over a range of laser wavelengths chosen to give access to different ionization regimes defined, as discussed below, by the Keldysh adiabaticity parameter whose values range from below unity (tunnelling regime) to far above unity (multiphoton ionization regime);

(ii) probing whether the possibility of resonance excitation of CS₂ to different electronic states affects the strong field induced dissociative ionization pattern; and

(iii) measuring the kinetic energies released upon dissociation of CS₂^{q+} ions ($q \geq 2$).

2. Experimental method

Our experiments were conducted in two different apparatuses, the common features of which are schematically depicted in figure 1. Measurement of fragmentation patterns at different laser wavelengths were conducted in two different crossed beams apparatuses in which a molecular beam intersected, at right angles, a focused laser beam from either an active-passive modelocked high-energy Nd-YAG laser or a dye laser pumped by this YAG laser. The YAG laser produced 35 ps pulses (up to 70 mJ per pulse at 1064 nm) at a repetition rate of 10 Hz. The maximum energy values at 532 nm and 355 nm were 35 mJ and 10 mJ, respectively. The dye laser could be tuned between 580 and 605 nm and produced 10 ps pulses at a maximum energy of 5 mJ. In addition, we used a Raman shifter containing H₂ gas at a pressure of 200 lb in⁻² and pumped by 532 nm laser radiation to produce radiation at 683 nm (first Stokes wavelength) of a maximum energy of 3 mJ.

Ions produced in the laser-molecule interaction were electrostatically accelerated by a field of 50–100 V cm⁻¹ into a quadrupole mass spectrometer. This field was sufficient to ensure near unit collection efficiency. As in our earlier measurements (Kumar *et al* 1994a, b), we calibrated our laser intensities by measuring the saturation intensity of singly charged rare gas ions (Xe⁺ and Kr⁺) and normalizing to the data of Perry *et al* (1988) and Lompré *et al* (1989). Maximum intensities used in the present experiment are in the region of 5×10^{14} W cm⁻² at 1064 nm.

For studies of multiple ionization, a somewhat different arrangement was utilized. Radiation at 1064 nm from the Nd-YAG laser was focused to a spot size of 40 μm and made to interact with an effusive molecular beam of CS₂. Positively-charged ions produced as a result of the interaction of CS₂ with the intense laser beam were electrostatically extracted into a linear time-of-flight (TOF) mass spectrometer, using typical extraction fields of the order of 100 V cm⁻¹; the intensity of mass-analysed ions was monitored by a channel electron multiplier (CEM) as a function of the energy density of the intense beam. The output pulses from the CEM were amplified and fed into a fast digital storage oscilloscope (DSO); a small portion of the input laser beam was reflected using a beam splitter to serve

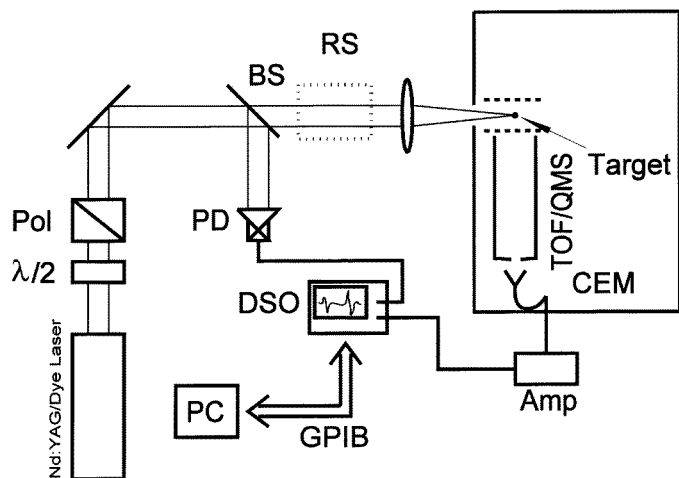

Figure 1. Schematic diagram outlining the main features of the two apparatuses used in the present experiments. The measurements of mass spectra at different laser wavelengths were carried out using a quadrupole mass spectrometer (QMS) whereas the covariance mapping utilized a linear time-of-flight (TOF) spectrometer. The laser-CS₂ interaction occurred in a zone identified as 'Target'. The Nd:YAG laser provided laser wavelengths of 1064 nm and its first and second harmonics; the dye laser was utilized for generation of 590 nm and the Raman shifter (RS) produced light at 683 nm wavelength. $\lambda/2$: halfwave plate, Pol: polarizer, BS: beam splitter, PD: photodetector, CEM: channel electron multiplier, DSO: digital oscilloscope connected by a fast data bus to a laboratory computer.

as a timing trigger for the DSO. The TOF spectrum from each laser shot was transferred from the DSO to a laboratory computer along a fast data bus (Safvan *et al* 1996).

3. Results and discussion

3.1. Fragmentation patterns at different laser wavelengths

The fragmentation pattern at a given laser wavelength would, in general, be expected to reflect on the relative importance of the cross section for molecular ionization and for dissociative ionization. Each of these would, in turn, depend on details of transition dipole moments and the existence of intermediate resonance states (either present in the molecule or induced by the incident laser field). Our earlier measurements of CS₂ mass spectra at 532 nm at laser intensities of 10^{12} – 10^{14} W cm⁻² (Kumar *et al* 1994a) yielded results which indicated that dissociation preceded ionization at the lower end of the intensity range; the mass spectra were dominated by fragment ion peaks (mostly by the S⁺ fragment) and the parent CS₂⁺ ion contributed only a little to the overall ion yield. Was such behaviour specific to 532 nm radiation? We now examine the mass spectra by using a laser wavelength of 590 nm, which is sufficiently distant from 532 nm to eliminate the possible effect of any resonances but is, nevertheless, close enough to the original wavelength to ensure that the dynamics occurs in the same ionization regime. To properly examine the role played by resonances, we need to know the molecular potential energy surfaces for the ground and various low-lying electronically excited states: to the best of our knowledge, these are not available for a triatomic such as CS₂. It is nevertheless, possible to carry out a morphological study by varying the laser wavelength over a wide enough range which might excite some

resonances (which, for triatomics, would be expected to be broad anyway). To examine the possible role of resonances in the fragmentation pattern, we have recorded mass spectra at different wavelengths and typical mass spectra, measured at approximately the same laser intensity are shown in figures 2 and 3.

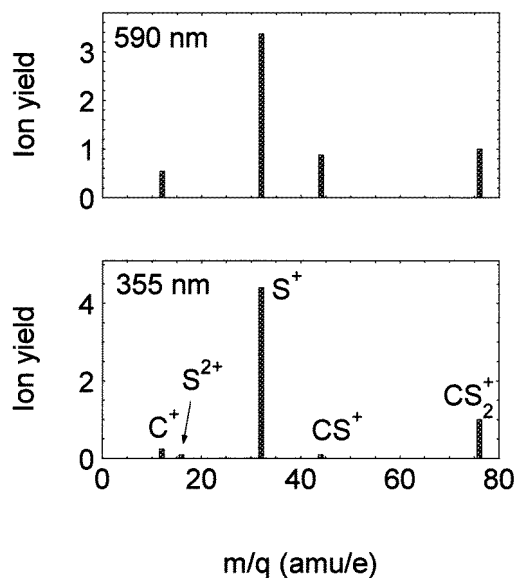

Figure 2. Mass spectra of CS₂ at 590 nm and 355 nm and intensity of $2 \times 10^{13} \text{ W cm}^{-2}$. The ion intensities have been normalized to the CS₂⁺ peak.

Our measurements at 590 nm, made using a Rhodamine 610 dye laser, yield a mass spectrum which is very similar to that reported earlier by us (Kumar *et al* 1994a) using 532 nm laser radiation. As in the latter spectrum, at 590 nm also the S⁺ fragment is the dominant ion; CS⁺ and C⁺ also appear prominently in the mass spectrum. Our measurements were made at several values of laser intensity over the range from 4.1×10^{12} – $4.3 \times 10^{13} \text{ W cm}^{-2}$ and the S⁺ ion continued to dominate the mass spectrum even at the lowest laser intensity, at both wavelengths. Moreover, spectra in the entire tuning range of the dye (20 nm) were similar to that obtained at 590 nm. It thus appears that preference for dissociation is not specific to 532 nm radiation.

The mass spectrum measured at the ultraviolet wavelength of 355 nm (the third harmonic of our Nd:YAG laser) is also shown in figure 2. Here too, the parent molecular ion, CS₂⁺, is much less abundant than the fragment ions. There is no major difference between this spectrum and those obtained at 532 nm and 590 nm. It is pertinent to note that measurements at this wavelength were particularly difficult because of the propensity of ultraviolet laser radiation to produce copious quantities of photoemitted electrons from metallic surfaces in the vicinity of the laser–molecule interaction zone. We carried out various experimental checks, including comparison of the presented spectra with that obtained using an electron beam, to ensure that the effect of secondary electrons was negligible in the data presented here.

The mass spectra obtained using 1064 nm laser radiation (figure 3), on the other hand, show significant differences from the spectra obtained at 532 nm, 590 nm and 355 nm in that the CS₂⁺ parent molecular ion dominates the spectrum; the fragment ions account for

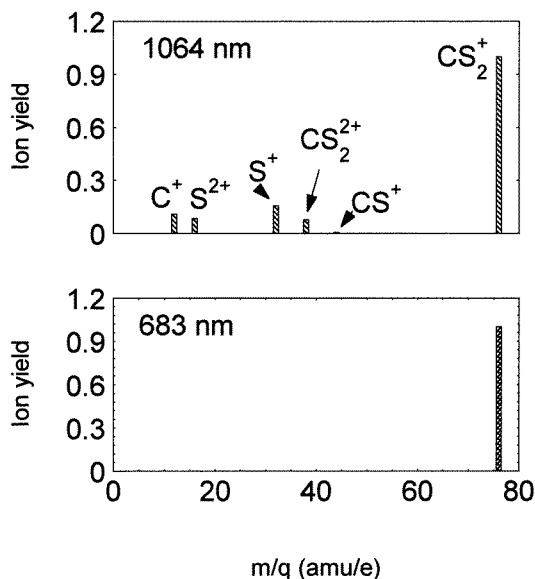

Figure 3. Mass spectra of CS₂ at 1064 nm (intensity of 2×10^{13} W cm⁻²) and 683 nm (intensity of 1.3×10^{13} W cm⁻²). The ion intensities have been normalized to the CS₂⁺ peak.

a minor component of the overall ion yield. The CS₂²⁺ dication is also observed at this wavelength and some tentative evidence for the trication was also obtained at the highest laser intensities used in the present experiments. Mass spectra were measured at 1064 nm over a wide range of laser intensities, from 1×10^{12} – 5×10^{14} W cm⁻²; the CS₂⁺ molecular ion was found to dominate the mass spectrum over this entire range of laser intensity. Even the dication, CS₂²⁺, appeared as prominently as the S⁺ fragment at higher values of laser intensity.

Figure 3 also shows a mass spectrum measured at 683 nm, at a laser intensity of 1.3×10^{13} W cm⁻². Although the use of a Raman shifter to obtain this wavelength precluded wide enough variation in laser intensities in the present experiments, it is clear that the spectrum at this wavelength is also significantly different from spectra obtained using 532 nm and 590 nm, and is, in fact, akin to the mass spectrum obtained 1064 nm in that the parent molecular ion dominates the mass spectrum: at this wavelength no signals pertaining to molecular fragmentation are observed.

The dynamics of the molecular dissociative ionization process clearly depends upon the laser wavelength. Specifically, it depends upon whether the laser–molecule interaction occurs in the multiphoton or the tunnelling regime, or in an intermediate regime (Walsh *et al* 1993, Kumar *et al* 1994a, b). The particular regime in which ionization occurs is defined by the Keldysh adiabaticity parameter, γ , which is the ratio of the laser field frequency to the tunnelling frequency. Quantitatively,

$$\gamma = \omega(2m_e V_{IE})^{1/2}/eE \quad (1)$$

where V_{IE} is the zero-field ionization energy of the molecule in its ground state, E is the electric field strength generated by the laser, ω is the angular frequency of the laser field, and e and m_e are the electronic charge and mass, respectively (Keldysh 1965). A value of $\gamma \ll 1$ indicates the tunnelling regime while $\gamma \gg 1$ implies multiphoton ionization. Ilkov *et al* (1992) have examined this criterion carefully and have suggested a more pragmatic

definition of the tunnelling regime as $\gamma < 0.5$. It may be argued that it is unrealistic to expect a single parameter, such as γ , to fully account for the rich dynamics that occur in laser–molecule interactions; for instance, it has been shown by Rhodes and coworkers (Luk *et al* 1992) that tunnel ionization can occur in the multiphoton ionization regime. Nevertheless, γ does provide a good indication of the gross features that may be expected when molecules are subjected to intense laser fields; there is sufficient evidence to suggest that the value of γ in any experimental situation provides a useful guidepost for the experimentalist and the present results appear to bear this out.

The wavelengths and intensities used in the measurements reported here place the Keldysh parameter in different regimes: the intermediate regime ($\gamma \sim 3$ at 532 nm and 590 nm); the multiphoton ionization regime ($\gamma = 8$ at 355 nm); or the tunnelling regime ($\gamma \sim 0.3$ at 1064 nm).

It is pertinent to note that the laser intensities used in the measurements of mass spectra were all below the saturation intensity of any ion (see below). The main feature of all the mass spectra measured in the multiphoton ionization regime, or in the intermediate regime, is the large abundance of fragment ions, much more than that of the parent molecular ion. It may also be noted that multiply charged ions are not observed at all at these wavelengths and at the intensities used. The differences in the mass spectrum measured in the tunnelling regime can be attributed, in the manner discussed earlier by Chin and coworkers (Walsh *et al* 1993), to ‘atom-like’ tunnel ionization of the parent molecule. It is the distortion of the potential surfaces that is most likely to be responsible for the dynamics governing the detachment of electrons and the breaking of molecular bonds in this regime.

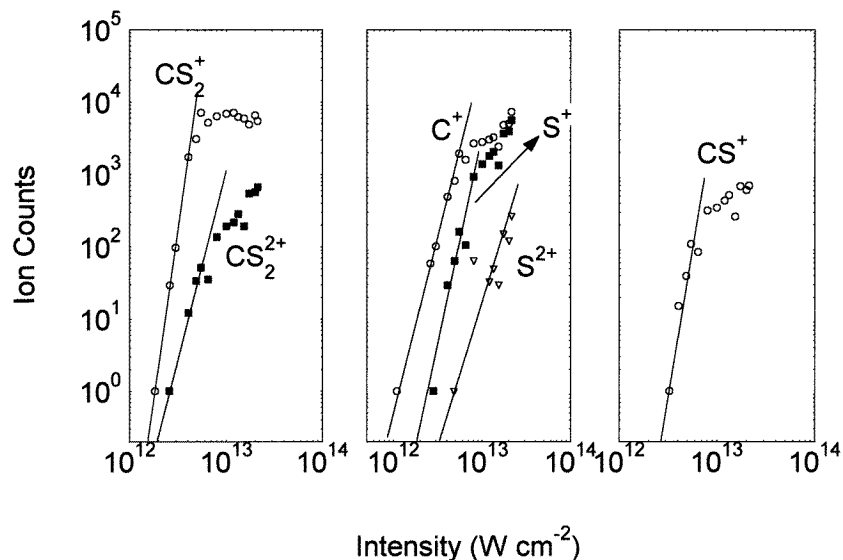

Figure 4. Variation of various ions as a function of incident laser intensity. Note the log–log scale. The saturation intensity is taken to be the point at which the data points deviate from the straight line portion of each curve at low values of laser intensity (see Kumar *et al* 1994b).

In our earlier studies (Kumar *et al* 1994a,b) we have had occasion to examine the abundances of different ions as a function of laser intensity at 532 nm in detail. In view of the differences in the dissociation dynamics observed in the tunnelling regime, we have

carried out similar measurements using 1064 radiation and some illustrative results are depicted in figure 4. In our log–log plot, all the data deviate from linearity at a suitably high laser intensity, which is known as the saturation intensity. The saturation intensities (I_{sat}) of different ions can tell us about the dynamics of the processes involved. In the present measurements, the saturation intensities were all in the region of $4\text{--}8 \times 10^{12} \text{ W cm}^{-2}$. It is of interest to consider this in the light of values of the thresholds for dissociative ionization (DI) obtained from electron impact methods; these show an increase in the following order: S^+ (14.8 eV) < CS^+ (16.7 eV) < C^+ (20 eV). Our measurements, on the other hand, clearly indicate (see figure 4) that I_{sat} for S^+ is higher than that for C^+ . Moreover, the value of I_{sat} for the CS_2^{2+} dication is only marginally higher than that for CS_2^+ , even though the double ionization energy of CS_2 is nearly a factor 2.5 times higher than the single ionization energy. The fact that I_{sat} values cannot be correlated in a simple fashion with zero-field molecular parameters such as DI thresholds (or ionization energies) indicates strongly that the distortion of the potential energy surfaces completely dominates the dissociation dynamics at 1064 nm (that is to say, in the tunnelling regime).

3.2. The possible role of resonances in the dissociative ionization of CS₂

In pursuit of our aim to study the possible role of resonances in the dissociation dynamics, we focus attention on the formation, or otherwise, of the S_2^+ product of the dissociative ionization of CS_2 using a laser wavelength of 355 nm. In the context of the present study, the formation of the S_2^+ fragment represents a particularly appropriate and unambiguous channel for dissociative ionization of CS_2 : in an earlier study (Mathur *et al* 1994a), we had compared the formation of the S_2^+ fragment by intense polarized and unpolarized electric fields. The former were created using intense laser fields whereas the latter arose in collisions of CS_2 with fast, positively charged projectiles (100 MeV Si^{8+} ions) as well as fast negatively charged ions and electrons.

The S_2^+ dimer ion was observed in collisions of charged particles (electrons, positive ions, negative ions) with CS_2 , over a wide range of particle velocities (from tens of eV up to hundreds of MeV); the appearance of the S_2^+ fragmentation channel has been established irrespective of the type of particles or the type of charge they carry (see Mathur *et al* 1994a, and references therein). The data pertaining to MeV ions of highly charged ions (such as Si^{8+}) incident on CS_2 are particularly relevant to our discussion here, because the magnitude of the electric fields experienced by the molecule in such a collision are quite similar to those arising in an intense, ultrashort pulse laser field. There is, however, one major difference in that the electric field in the laser pulse is *polarized*, unlike that exerted by the fast ion projectile. Rhodes and coworkers (Luk *et al* 1993) have pointed out that the polarization of the laser electric field causes important changes in the fragmentation process and have attributed the site-specific dissociation of N_2O in an intense laser field to the polarization characteristics of the incident laser field. In an earlier study of the dissociative ionization of CH_4 , we have also shown how polarization effects can dramatically alter the fragmentation pattern, especially leading to the suppression of specific bond breaking channels when intense polarized laser radiation is used (Mathur *et al* 1994b).

In our earlier studies on this molecule at 532 nm and 1064 nm (Mathur *et al* 1994a), we did not observe the S_2^+ fragment ion. We interpreted this to be due to (i) preference for dissociation over ionization and (ii) a large induced dipole moment and the resulting alignment of the molecule with the laser field. The latter effect plays a very crucial role in the sense that the two sulphur atoms, which are the peripheral positions in linear, ground-state CS_2 , are not allowed to come close enough to enable the formation of a bound

state of the dimer ion (the average separation between the two S atoms being of the order of 3.3 Å).

Krishnamurthy and Mathur (1995) have recently reported the results of high-resolution energy loss spectrometry experiments on CS₂; their data indicate the existence of an electronically excited state (a ³A₂, of bent geometrical configuration) at an energy corresponding almost exactly to 355 nm radiation. Moreover, there is a broad band of excited states covering the energy region from 7.5 eV to the first ionization energy of CS₂ (10.08 eV) in which there is a high density of excited states possessing bent equilibrium configurations. Laser irradiation at different wavelengths provides an excellent opportunity to effectively probe the possible role of resonances in the dynamics of intense field ionization/dissociation. At different laser wavelengths, especially at 355 nm, the presence of one-photon (or multiphoton) resonances can lead to the formation of a bent CS₂ molecule in electronically excited states. Do such resonances facilitate the formation of the S₂⁺ dimer ion?

Our careful and extensive search for the S₂⁺ ion peak in mass spectra at all the laser wavelengths used in the present experiments leads us to answer this question in the negative. Moreover, the non-observation of S₂⁺, even at the highest laser intensities employed in the present experiments, leads us to postulate that the polarized laser radiation affects the electronic charge cloud density distribution in such a manner that excitation to certain (bent) electronic states, and subsequent bond-breakages, become significantly less likely (Mathur *et al* 1994b).

3.3. Dissociation of multiply charged CS₂ molecules

The interaction of molecules with intense laser fields can also result in the ejection of more than one electron, leading to the formation of metastable and unstable states of multiply charged molecular ions which dissociate, either by tunnelling through a potential barrier or spontaneously (Mathur 1993). Earlier measurements of the distribution of kinetic energies released upon dissociation of such molecules have indicated that the values are consistently lower than those expected on the basis of a simple Coulomb explosion; dissociation along non-Coulombic potential energy curves has been postulated (Safvan and Mathur 1994) to account for this deviation. There are also indications which suggest that dissociation of such ions may occur at internuclear distances which are significantly larger than the equilibrium separations (Normand *et al* 1991, Codling *et al* 1991, Schmidt *et al* 1994, and references therein). Concepts such as bond softening and electron localization have been introduced in a number of recent theoretical attempts to model the dissociation dynamics of diatomic molecules (see, for instance, Zavriyev *et al* 1993, Seideman *et al* 1995, Ilkov *et al* 1995, Posthumus *et al* 1995).

We have carried out studies of the multiple ionization of CS₂ at 1064 nm. Our measurement procedure was as follows. A TOF mass spectrometer was used in the apparatus depicted in figure 1 to obtain mass spectra which were typically accumulated and averaged over 10 000–30 000 laser shots. The dissociation dynamics of highly charged states of CS₂ was probed by means of coincidence techniques applied to detection of mass-selected fragment ions. At the highest laser intensities used in these experiments, many ions can be generated with a single laser pulse, populating an entire range of charge states. Sequential ionization by additional photons may also occur for laser intensities of the order of 10¹⁴ W cm⁻². Under such circumstances, conventional coincidence techniques have to be replaced by other data handling techniques. Covariance mapping is one such coincidence

technique that has found utility in studies of fragmentation dynamics of multiply charged molecules (Frasinski *et al* 1989a).

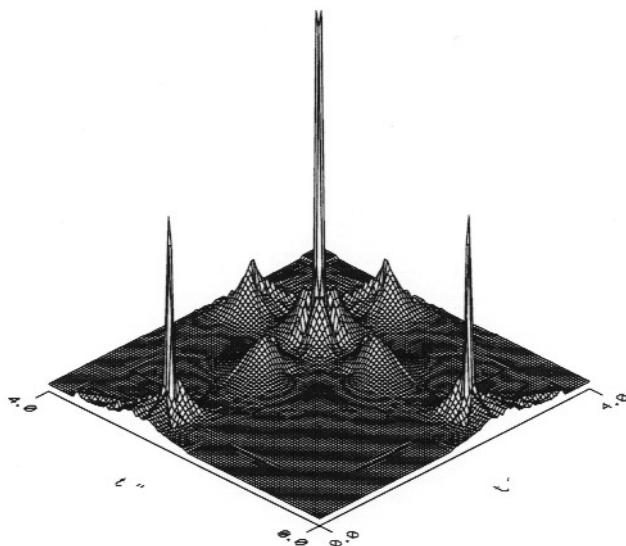

Figure 5. A covariance map of CS₂ obtained using 35 ps pulses of 1064 nm laser radiation at an intensity of 1×10^{14} W cm⁻². The most prominent peak at the centre of the map corresponds to formation of S⁺-S⁺ ion-pairs; all other ion-pairs are most clearly identified by taking a slice through the covariance map, as shown in the example in figure 6.

A typical covariance map obtained for CS₂ (at 1064 nm, using a laser intensity of 1×10^{14} W cm⁻²) is shown in figure 5. The peaks represent a map of true coincidence signals between pairs of ions which result from dissociation of CS₂^{q+} when $q \geq 2$. The true coincidence signals arise from correlated ion pairs. False coincidences can arise from uncorrelated ions which arrive by chance at the appropriate times; these have been removed using a methodology similar to that recently described in detail elsewhere (Frasinski *et al* 1989b). The interaction zone in our experiment has a diameter of 40 μm; at typical ion extraction fields of 100 V cm⁻¹, the corresponding time spread gives rise to an ion energy spread of the order of only tens of meV, much smaller than the energy values of interest in the present study.

The following ion-pairs are clearly observed in our covariance map: S⁺ + S⁺, S⁺ + C⁺, S⁺ + CS⁺ and S⁺ + CS²⁺. All these ion-pairs can be most clearly identified by making an appropriate slice through the three-dimensional plot shown in figure 5; the resulting spectrum, shown in figure 6 for double coincidences involving S⁺ ions, resembles a conventional double coincidence TOF spectrum. For the S⁺-S⁺ ion-pair, which is the most prominent of the peaks in figure 5, note the apparent dip in the coincidence peak; this is due to the automatic rejection of self-coincidences which occur within the dead-time of the channel electron multiplier detector. S⁺-C⁺ ion-pairs also appear with some prominence in figure 5. In addition, there is clear evidence for the formation of S⁺-CS⁺ pairs and S⁺-CS²⁺ pairs (figure 6). Many such coincidence spectra were measured in the course of this study, at different laser intensities with different values of resolution (including enhanced resolution which was adequate to clearly resolve the S⁺-¹²C⁺ ion peak from the very much weaker S⁺-¹³C⁺ peak, as shown most clearly in figure 5).

The precursors of most of the ion-pairs observed in the coincidence spectra depicted

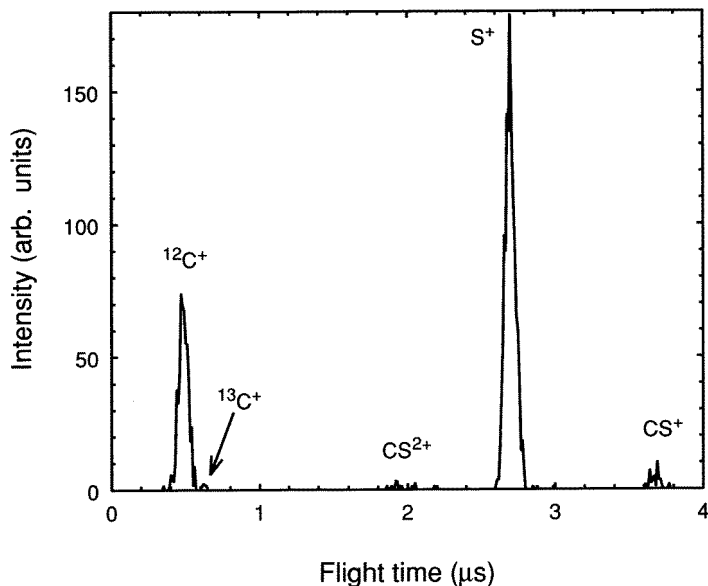

Figure 6. A slice through the covariance map shown in figure 5 showing peaks corresponding to coincidence of S^+ with other ions.

in figures 5 and 6 are different electronic states of the CS_2^{2+} dication. The presence of the S^+-CS^{2+} ion-pair also indicates that charge states of CS_2 which are higher than 2+ come into play under our experimental conditions. Consider CS_2^{3+} as a possible precursor of such ion-pairs. Assuming that this trication would preferentially dissociate into three symmetrical fragments, S^+ , C^+ and S^+ , we have also measured triple coincidence spectra for these three ion-triplets and the resulting spectrum, although very weak, offered indications that symmetric fragmentation of the trication was part of the overall dynamics in the present experiment. Detailed analysis of this information is, however, precluded not only by the technical difficulties we experienced in eliminating, in an unambiguous manner, the contribution made by false coincidences but also by the total lack of data on the potential energy surfaces of any electronic state of CS_2^{3+} .

The electronic states of the CS_2^{2+} dication, on the other hand, have been the subject of extensive calculations and experimentation (see, for instance, Mille *et al* 1986, Eland 1987, Hagan and Eland 1989, Mathur and Harris 1989, Mathur 1993). The valence-shell electronic configuration of the ground electronic state of the neutral molecule can be written as $6\sigma_g^2 5\sigma_u^2 2\pi_u^4 \pi_g^4$. Removal of two electrons from the outermost π_g orbital leads to formation of dication states $^3\Sigma_g^-$, $^1\Delta$ and $^1\Sigma_g^+$. Dication states of $^1\Delta_u$ and $^1\Sigma_u^+$ state become accessible if one electron is removed from the π_g and π_u orbitals, respectively. Millie *et al* (1986) have considered an entire gamut of such states and have calculated that the most probable dissociation limits (and relative weights, RW) of low-lying CS_2^{2+} dication states will be:

$S^+ + C + S^+$ (RW = 0.5), $S^+ + C^+ + S$ (RW = 0.25), $S^+ + C^- + S^{2+}$ (RW = 0.15) and $S^{2+} + C + S$ (RW = 0.05).

The relative peak intensities in figures 4 and 5 are in remarkable accord with the calculated values of RW for the dissociation of the CS_2^{2+} dication. On the experimental front, other coincidence experiments have been conducted. Hagan and Eland (1989) used

a beam of 1.5-keV electrons; the major ion-pairs observed in these experiments were: S⁺ + CS⁺, S⁺ + C⁺, S⁺ + S⁺, with relatively weak contributions to the coincidence signal from C⁺ + S²⁺, S²⁺ + S⁺ and CS²⁺ + S⁺ pairs. The major ion-pairs observed in these electron-impact experiments were also observed in single-photon photoionization (photoion-photoion coincidence) experiments (Eland 1987). The kinetic energies released upon dissociation of the CS₂²⁺ precursor were measured to be 4.2 ± 0.4 eV (for the channel leading to S⁺ + CS⁺ ion-pair formation), 6.6 ± 1.3 eV (for the S⁺ + C⁺ channel), and 6.9 ± 2.0 eV (for the S⁺ + S⁺ channel).

In all the present measurements, the peaks in coincidence spectra were devoid of structure which might be indicative of many-valued kinetic energy releases and of forward-backward ion scattering. This lack of structure is indicative of small values of kinetic energy release. In the absence of forward-backward peaks in our coincidence spectra, which would make determination of kinetic energy release values somewhat more reliable, we have determined values of the average kinetic energy releases by measuring the full-widths at half-maxima of the peaks measured in our coincidence spectra. The values thus deduced are found to be considerably smaller than those obtained in the earlier electron-impact and single-photon experiments: our values for the kinetic energy releases are: 0.18 ± 0.05 eV (for the channel leading to S⁺ + CS⁺ ion-pair formation); 0.52 ± 0.05 eV (for the S⁺ + C⁺ channel); and 0.27 ± 0.05 eV (for the S⁺ + S⁺ channel). What gives rise to this dramatic difference in kinetic energy release values obtained in single-photon experiments and in the present intense laser field measurements?

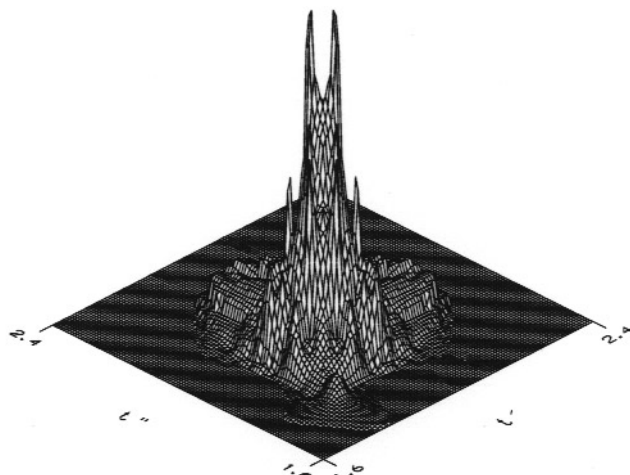

Figure 7. A covariance map of H₂ obtained using 35 ps pulses of 1064 nm laser radiation at an intensity of 2×10^{14} W cm⁻².

Before probing this question further it is of importance to check the veracity of the present measurements and our methodology; in order to accomplish this, we have also carried out measurements on the H₂ molecule. A typical covariance map obtained at 1064 nm, at an intensity of 2×10^{13} W cm⁻², is shown in figure 7. Forward and backward scattered H⁺ peaks arising out of dissociation of H₂²⁺ are observed in our map; further details of these measurements will be presented elsewhere but for the present it is sufficient to draw attention to the values of kinetic energy release that can be determined from our measurements. The kinetic energy distribution is shown in figure 8; the most probable H⁺

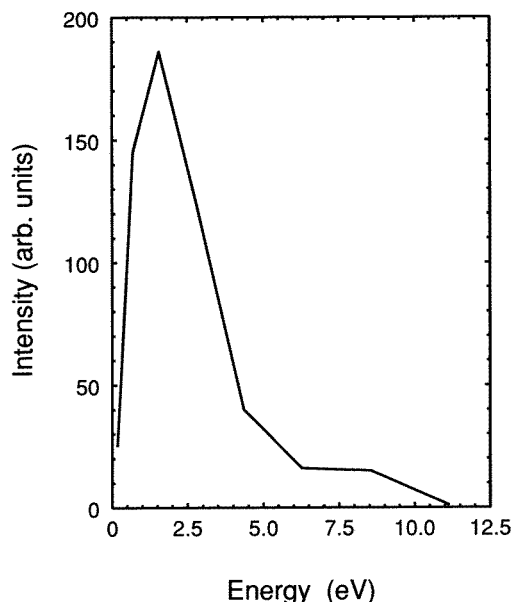

Figure 8. Distribution of the kinetic energies of H^+ arising from irradiation of H_2 by 1064 nm laser radiation at an intensity of $2 \times 10^{14} \text{ W cm}^{-2}$.

kinetic energy is deduced to be approximately 2.0 eV, with a distribution which extends to approximately 11 eV. These values are in excellent accord with those determined in the earlier measurements of Frasiniski *et al* (1992) (carried out at a laser wavelength of 600 nm, pulse length of 3 ps and an intensity of approximately $10^{15} \text{ W cm}^{-2}$) and help to lend credence to the methodology utilized in the present experiments on CS_2 .

Before we consider some conjectures regarding the low KER values obtained for CS_2 , it is pertinent to note that the overall dissociation dynamics must be governed by the competition between intense-field-induced ionization and dissociation. The mass spectra at 1064 nm indicate that the laser- CS_2 interaction leads to the following likely sequence of events: ionization of CS_2 occurs first, to be subsequently followed by dissociation of various electronic states of CS_2^{q+} , with values of q probably covering the range from 1 to 3 in the present case.

Multiple ionization of diatomic molecules using intense laser fields has been studied in a number of laboratories (see, for instance, Boyer *et al* 1989, Cornaggia *et al* 1992, Hill *et al* 1992) and evidence exists that the kinetic energy release values measured in such experiments are independent of laser intensity, laser wavelength and pulse duration in the picosecond and femtosecond regimes (Cornaggia *et al* 1991, Codling and Frasiniski 1993). It appears well established that dissociation of such ions yields kinetic energy release values which are generally *lower* than those that would be expected on simple Coulomb-explosion considerations. Non-Coulombic potential energy functions have been invoked to account for such observations (Safvan and Mathur 1994), as have explanations involving dissociation occurring at internuclear separations larger than the equilibrium ones (Normand *et al* 1991, Codling *et al* 1991).

Invoking dissociation along non-Coulombic potential energy curves does not lead to any further insight in the case of a triatomic like system CS_2 as knowledge of the relevant potential energy surfaces is simply not available at present. Dissociation which occurs

at internuclear distances larger than the equilibrium separations is closely related to the concept of bond-softening that has been invoked in explanation of results obtained in intense field experiments on H₂⁺ (Bucksbaum *et al* 1990, Zavriyev *et al* 1993). It has been shown that an intense laser field gives rise to molecular dressed states which are coherent superpositions of field-free bonding and anti-bonding electronic states; as a result of avoided crossings, H₂⁺ ions can be trapped in laser-induced vibrational states at large values of internuclear separation. Normally, one would expect that as the internuclear separation increases, the electron density distribution becomes more localized, thus making it less likely that charge transfer effects might account for low values of KER of the fragments. However, the formation of quasi-bound states at large internuclear distances, and the subsequent dissociation (spontaneous or laser-induced) of such trapped states can give rise to kinetic energy releases which are significantly smaller than would be expected if the dissociation had occurred at the equilibrium (zero-field) distance.

A further development of bond-softening ideas considers the effect that the ejected electrons have on the dissociation dynamics and, concomitantly, upon the kinetic energy release values. Schafer *et al* (1993) and Corkum (1993) have shown that the quiver motion of the ejected electrons can lead to scattering processes involving the molecular ion core. Such electron–nucleus couplings can modify the time evolution of the internuclear distance in the course of the dissociative ionization process. Theoretical treatment of how such electron–nucleus couplings determine the dissociation dynamics of triatomic systems like CS₂ remain to be carried out. It may, of course, turn out that for picosecond pulses of the type used in the present experiments such effects are not significant. Nevertheless, time-dependent quantal calculations are clearly urgently required to be carried out in order to make a proper quantitative assessment of the effect of laser-induced polarization of the molecular electronic charge cloud and concomitant deformation of the internuclear geometry.

It is also possible that the low KER values might be indicative of a sequential laser-induced process of the type: CS₂ → CS₂⁺* → CS + S⁺ followed by CS → S⁺ + C. The first step of such a process is dissociative ionization of CS₂ and, as the CS and S⁺ fragments separate, the CS fragment is further dissociatively ionized. The time separation between the two steps would be expected to be of the order of a few hundred femtoseconds, the two S⁺ ions resulting from such a sequential process would appear to be correlated in time in our present experiments and would contribute to the covariance map measured here. The KER values expected in such a two-step process would, however, be much lower than those that would arise out of a single-step dissociation of the CS₂²⁺ dication. Pump-probe experiments carried out using femtosecond laser pulses may help to further elucidate the dynamics.

4. Summary

We have carried out measurements of the mass spectra of CS₂ subjected to intense laser irradiation over a range of wavelengths covering the region from the infrared to the ultraviolet. The corresponding range of the Keldysh adiabaticity parameter covers the multiphoton ionization regime, the intermediate regime as well as the tunnelling regime. The dynamics of the dissociative ionization process is clearly dependent upon the nature of the regime in which the laser–molecule interaction occurs. Moreover, the existence of possible resonances which could access electronically excited states of the molecule appears to have little part to play in the dynamics. This indicates that the strong field aspect of the interaction, which leads to the distortion of molecular potential energy surfaces (creation of dressed surfaces), is the dominating feature in such laser–molecule interactions. This is also indicated in our results of measurements of ion intensity as a function of laser intensity; at

1064 nm there appears to be no correlation between the values of saturation intensity for various ions and their dissociative ionization thresholds or ionization energies.

Further, covariance mapping has been applied to study the dissociation dynamics of CS_2^{q+} ions. The measured values of kinetic energy release accompanying formation of fragment ion-pairs are very significantly less than those measured in a number of earlier experiments in which multiple ionization was accomplished using either single-photon sources or by electron-impact. We postulate that this reduction may also be a manifestation of the extent to which potential energy surfaces of CS_2^{q+} ions are 'flattened' by the action of the intense, linearly polarized laser radiation in a manner which is akin to the bond-softening process that has been observed in the case of diatomic molecules. There is clearly an urgent necessity for high-level calculations of the dressed potential energy surfaces of triatomics like CS_2 with a view to elucidating the nature of bond-softening processes in such molecules.

Acknowledgments

We are grateful to A Sevian and K Vijayalakshmi for assistance during different stages of the measurements.

References

- Bandrauk A D 1994 *Molecules in Laser Fields* (New York: Dekker)
- Boyer K, Luk T S, Solem J C and Rhodes C K 1989 *Phys. Rev. A* **39** 1186
- Bucksbaum P H, Zavriyev A, Muller H G and Schumacher D W 1990 *Phys. Rev. Lett.* **64** 1883
- Codling K, Cornaggia C, Frasinski L J, Hatherly P A, Morellec J and Normand D 1991 *J. Phys. B: At. Mol. Opt. Phys.* **24** L593
- Codling K and Frasinski L J 1993 *J. Phys. B: At. Mol. Opt. Phys.* **26** 783
- Corkum P B 1993 *Phys. Rev. Lett.* **71** 1994
- Corkum P B and Dietrich P 1993 *Comm. in At. Mol. Phys.* **28** 357
- Cornaggia C, Lavancier J, Normand D, Morellec J, Agostini P, Chambaret J P and Antonetti A 1991 *Phys. Rev. A* **44** 4499
- Cornaggia C, Normand D and Morellec J 1992 *J. Phys. B: At. Mol. Opt. Phys.* **25** L415
- Dietrich P, Strickland D T, Laberge M and Corkum P B 1993 *Phys. Rev. A* **47** 2305
- Eland J H D 1987 *Mol. Phys.* **61** 725
- Frasinski L J, Codling K and Hatherly P A 1989a *Science* **246** 973
- Frasinski L J, Stankiewicz M, Hatherly P A and Codling K 1989b *Meas. Sci. Technol.* **3** 1188
- Frasinski L J, Stankiewicz M, Hatherly P A, Cross G M, Codling K, Langley A J and Shaikh W 1992 *Phys. Rev. A* **46** R6789
- Guisti-Suzor A, Mies F H, DiMauro L F, Charron E, Yang B 1995 *J. Phys. B: At. Mol. Opt. Phys.* **28** 309
- Hagan D A and Eland J H D 1989 *Rapid Commun. Mass Spectrom.* **6** 186
- Hill W T, Zhu J, Hatten D L, Cui Y, Goldhar J and Yang S 1992 *Phys. Rev. Lett.* **69** 2646
- Ilkov F A, Decker J E and Chin S L 1992 *J. Phys. B: At. Mol. Opt. Phys.* **25** 4005
- Ilkov F A, Walsh T D G, Turgeon S and Chin S L 1995 *Phys. Rev. A* **51** R1
- Keldysh L V 1965 *Sov. Phys.-JETP* **20** 1307
- Krishnamurthy M and Mathur D 1995 *J. Phys. B: At. Mol. Opt. Phys.* **28** L367
- Kumar G R, Gross P, Safvan C P, Rajgara F A and Mathur D 1996a *Phys. Rev. A* **53** at press
- 1996b *J. Phys. B: At. Mol. Opt. Phys.* **29** L95
- Kumar G R, Safvan C P, Rajgara F A and Mathur D 1994a *J. Phys. B: At. Mol. Opt. Phys.* **27** 2981
- 1994b *Chem. Phys. Letts.* **217** 626
- Lompré L-A, L'Huillier A and Mainfray G 1989 *Fundamentals of Laser Interactions II* ed F Ehlotzky (Berlin: Springer) p 67
- Luk T S, McPherson A, Boyer K and Rhodes C K 1992 *Atoms in Intense Laser Fields* ed M Gavril (San Diego: Academic) p 212
- Luk T S, Tate D A, Boyer K and Rhodes C K 1993 *Phys. Rev. A* **48** 1359

- Mathur D 1993 *Phys. Rep.* **225** 193
- Mathur D and Harris F M 1989 *Mass Spectrom. Rev.* **8** 269
- Mathur D, Kumar G R, Safvan C P and Rajgara F A 1994a *J. Phys. B: At. Mol. Opt. Phys.* **27** L603
- Mathur D, Safvan C P, Kumar G R and Krishnamurthy M 1994b *Phys. Rev. A* **50** R7
- Millie P, Nenner I, Archirel P, Lablanquie P, Fournier P and Eland J H D 1986 *J. Chem. Phys.* **84** 1259
- Normand D, Cornaggia C, Lavancier J, Morellec J and Liu H X 1991 *Phys. Rev. A* **44** 475
- Normand D, Lompré L A and Cornaggia C 1992 *J. Phys. B: At. Mol. Opt. Phys.* **25** L497
- Perry M D, Landen O L, Szöke and Campbell E M 1988 *Phys. Rev. A* **37** 747
- Posthumus J H, Frasiniski L J, Giles A J and Codling K 1995 *J. Phys. B: At. Mol. Opt. Phys.* **28** L349
- Safvan C P and Mathur D 1994 *J. Phys. B: At. Mol. Opt. Phys.* **27** 4073
- Safvan C P, Rajgara F A, Bhardwaj V R, Kumar G R and Mathur D 1996 *Chem. Phys. Lett.* at press
- Schafer K J, Baorui Yang, DiMauro L F and Kulander K C 1993 *Phys. Rev. Lett.* **70** 1599
- Schmidt M, Cornaggia C and Normand D 1994 *Phys. Rev. A* **50** 5037
- Seideman T, Ivanov M V and Corkum P B 1995 *Phys. Rev. Lett.* **75** 2819
- Walsh T D G, Decker J E and Chin S L 1993 *J. Phys. B: At. Mol. Opt. Phys.* **26** L85
- Zavriyev A, Bucksbaum P H, Squier J and Salane F 1993 *Phys. Rev. Lett.* **70** 1077