

## Output characteristics of a 400 MW Nd:glass laser system

R BHATNAGAR, P D GUPTA, B S NARAYAN, M ANWAR  
B L GUPTA and D D BHAWALKAR

Laser Section, Bhabha Atomic Research Centre, Trombay, Bombay 400 085

MS received 20 July 1978; revised 6 January 1979

**Abstract.** The paper discusses the performance characteristics of a Nd: glass laser system designed for laser produced plasma studies. It consists of a *Q*-switched oscillator followed by two amplifier stages. The output behaviour of the oscillator, i.e. laser pulse duration, peak power and optimum coupling, has been studied and is in good agreement with theory. Gain characteristics of amplifiers were obtained as a function of various parameters. Energies in excess of 7 J with pulse durations as small as 18 nsec were obtained giving rise to 400 MW peak power.

**Keywords.** *Q*-switching; pulse amplification; gain saturation; high power laser.

### 1. Introduction

The possibility of using lasers for heating dense plasmas of very high temperature was considered soon after the invention of the laser (Basov *et al* 1964; Dawson 1964). Several high power Nd:Glass and CO<sub>2</sub> lasers are currently being used for these studies. These laser systems essentially consists of a low power oscillator followed by several stages of amplifiers (Hagen 1969; Basov *et al* 1968; Grek *et al* 1977; Kachen 1971). The relatively low power in the oscillator ensures flux densities below the damage threshold of various components and better beam control. In amplifiers the important factors are the gain, energy extraction characteristics, optical damage, premature oscillations due to feedback, etc. In this paper we discuss the design and performance characteristics of a three stage Nd:glass laser system giving 400 MW peak power in about 20 nsec full width at half maximum (FWHM) pulse.

### 2. Experimental set-up

The block diagram of the system is shown in figure 1. A Nd<sup>3+</sup> glass oscillator with laser rod of 10 mm diameter (SG 91 H Hoya Glass) and 150 mm length is followed by two amplifiers of 12 mm diameter (LG 650 Schott Glass) and 19 mm diameter (SG 91 H Hoya Glass), each 300 mm long. The diameter of the amplifier rods is increased successively to keep the power density below the damage threshold of the glass material. Self oscillations of amplifiers are avoided by using laser rods with end faces cut at 6°. Each stage of the system is pumped by four xenon filled linear flash lamps enclosed in clover leaf reflectors (Ross 1964). A solution of sodium nitrite is circulated around the laser rods to cool and cut off the ultraviolet radiation from the flash

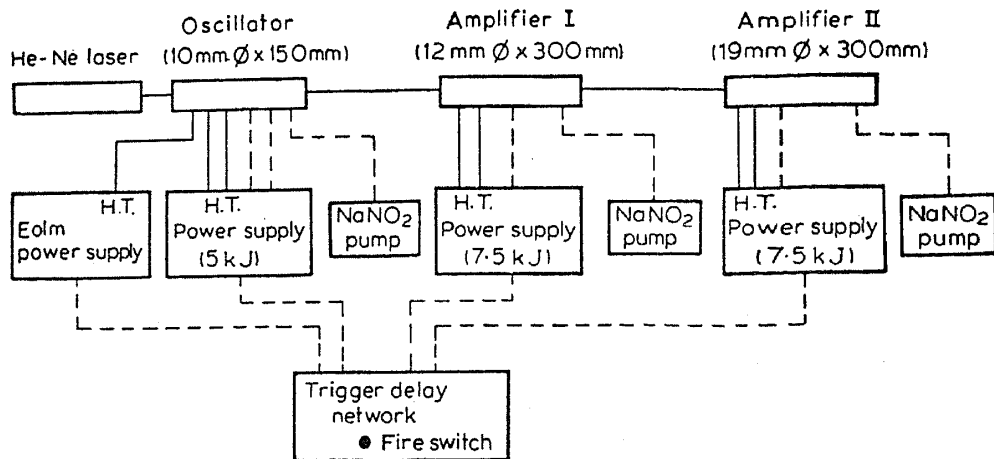

Figure 1. Block diagram of the laser system

lamps. The flash lamps pulse duration were 400  $\mu$  sec, 550  $\mu$  sec and 450  $\mu$  sec respectively whereas the fluorescent life time for the glass are 300  $\mu$  sec, 640  $\mu$  sec and 300  $\mu$  sec respectively. It is apparent from this that individual stages will reach peak inversion at different times. Appropriate time delays are introduced between the firings of different stages and opening of the electrooptic light modulator (EOLM) switch. The sequential firing of the stages is controlled by a trigger delay network (Bhatnagar et al 1978).

### 2.1. Oscillator

The oscillator shown schematically in figure 2 consisted of two mirrors  $M_1$  and  $M_2$ , an EOLM glass polariser and a glass rod. A 6 mm aperture was used to restrict the number of transverse modes. The optimum reflectivity of the output mirror can be estimated from threshold energy measurements. Exact calculations for pulsed

- |            |                                |    |                             |
|------------|--------------------------------|----|-----------------------------|
| B. S.      | -Beam splitter                 | R  | -Nd <sup>3+</sup> glass rod |
| $M_1, M_2$ | -Resonator mirrors             | A  | -Circular aperture          |
| P          | -GlanThomson polariser         | Ac | -Autocollimator             |
| M          | -Electro-optic light modulator |    |                             |

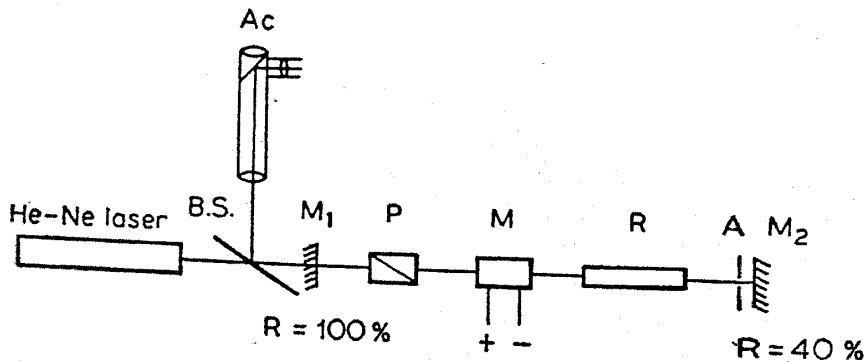

Figure 2. Schematic diagram of the oscillator

laser are not straightforward. For steady state lasers the optimum reflectivity is given by (Walter-Kuechner, 1976)

$$R_{\text{opt}} = 1 - \frac{(2KP_{\text{in}}L)^{1/2} - L}{1+L}$$

where  $K$  is the slope of the curve for threshold energy vs  $(-\log R)$  i.e.

$$K = \frac{1}{2} d \frac{(-\ln R)}{dP_{\text{th}}},$$

and

$$L = \frac{P_{\text{th}} \ln(R) - P'_{\text{th}} \ln(R'')}{P'_{\text{th}} - P_{\text{th}}},$$

where  $P_{\text{th}}(R)$  is the threshold energy for reflectivity  $R$  and  $P_{\text{in}}$  is the input energy.

From the plot of threshold energy vs  $(-\log R)$  for the oscillator

$$K = 0.83 \text{ (kJ}^{-1}\text{)} \text{ and } L = 0.715.$$

For input energy of 2.35 kJ the optimum reflectivity for normal oscillations case comes to be 43% and for a  $Q$ -switched case the optimum reflectivity should be still lower. Hence a mirror of 40% reflectivity was used for  $Q$ -switch operation.

The switching of voltage on the modulator was done using a Krytron KN-22 which gave switching time as fast as 5 nsec. The delay between the flash lamp firing and switching of the EOLM voltage was optimised and was found to be 370  $\mu$  sec. The  $Q$ -switched pulse was detected by a biplanar photodiode ITT 400 (rise time 0.3 nsec) and displayed on a tektronix oscilloscope. Figure 3 shows the variation of output power and pulse duration at different input energies with a typical pulse shape shown in the inset.

Output energies can be calculated from stored energy consideration. The threshold population inversion for the system is  $5.7 \times 10^{17}/\text{cc}$ . For a pump energy of 2.35 kJ, the population inversion comes out to be  $1.3 \times 10^{18}/\text{cc}$ . For an aperture of 6 mm and exposed length of the rod 10 cm, the total population inversion is  $3.7 \times 10^{18}$ . For photon energy of 1.17 eV ( $\lambda = 1.06 \mu$ ), the stored energy is 0.7 J. Using energy utilisation factor of 0.86 for a final population inversion 2.3 times the threshold (Steele 1965), the energy output is approximately 0.6 J.

The half width of the pulse can be calculated from the analysis of  $Q$ -switch pulse by Wagner and Lengyel (1963). The cavity decay time  $t_c$ , for an optical path of 58 cm and effective reflectivity of 15% is 4.5 nsec. For pump energy 2.3 times the threshold energy, the pulse width is given to be  $3.7 t_c$ . Thus the pulse width for input energies of 2.35 kJ comes out to be 16.5 nsec, in good agreement with the experimentally observed value. The output power and pulse durations of the laser were similarly calculated for different input energies and are shown in figure 3. The agreement with experimentally observed values is good.

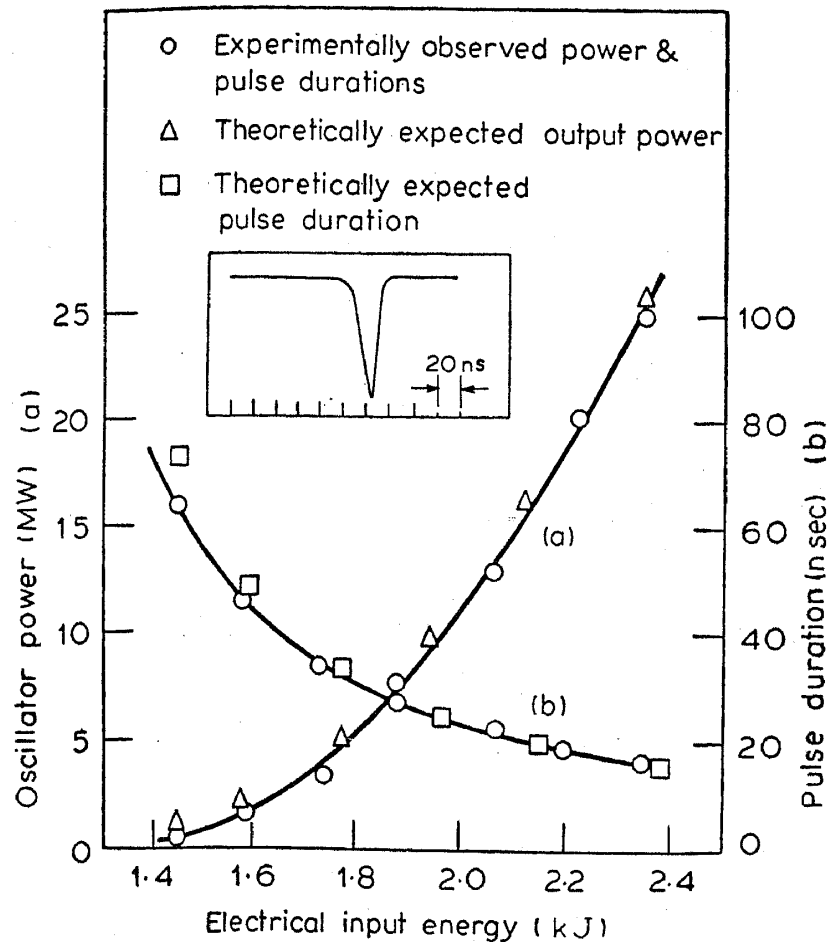

Figure 3. Oscillator output power and pulse duration vs electrical input energy

## 2.2. Amplifiers

The gain characteristics of the amplifiers were studied by simultaneously measuring the input and output power. Variation of gain with electrical input energy for both the amplifiers at different laser inputs is shown in figure 4. It is seen that at higher electrical input energies the first amplifier goes in saturation region. This is found to be consistent with the stored energy calculations. For an electrical input of 6 kJ to this amplifier and laser input of 0.45 J (25 MW, 18 n sec), the extracted energy is 2.5 J about half the stored energy, suggesting saturation operation of the amplifier. It is noted that the second amplifier is not driven in saturation region for the same inputs. This results from the fact that oscillator beam divergence is 2 m radians and the spot size increases to  $\sim 10$  mm at the input of second amplifier. This reduces the incident energy density of the laser much below the saturation energy density of the amplifier glass. However, the second amplifier is driven in saturation region for higher input laser energies of 1.7 J (95 MW, 18 n sec pulse). The system gave maximum energies of 8 J with peak powers of  $\sim 400$  MW. Pulse duration could be changed from 18 to 70 nsec by changing the electrical input to the oscillator.

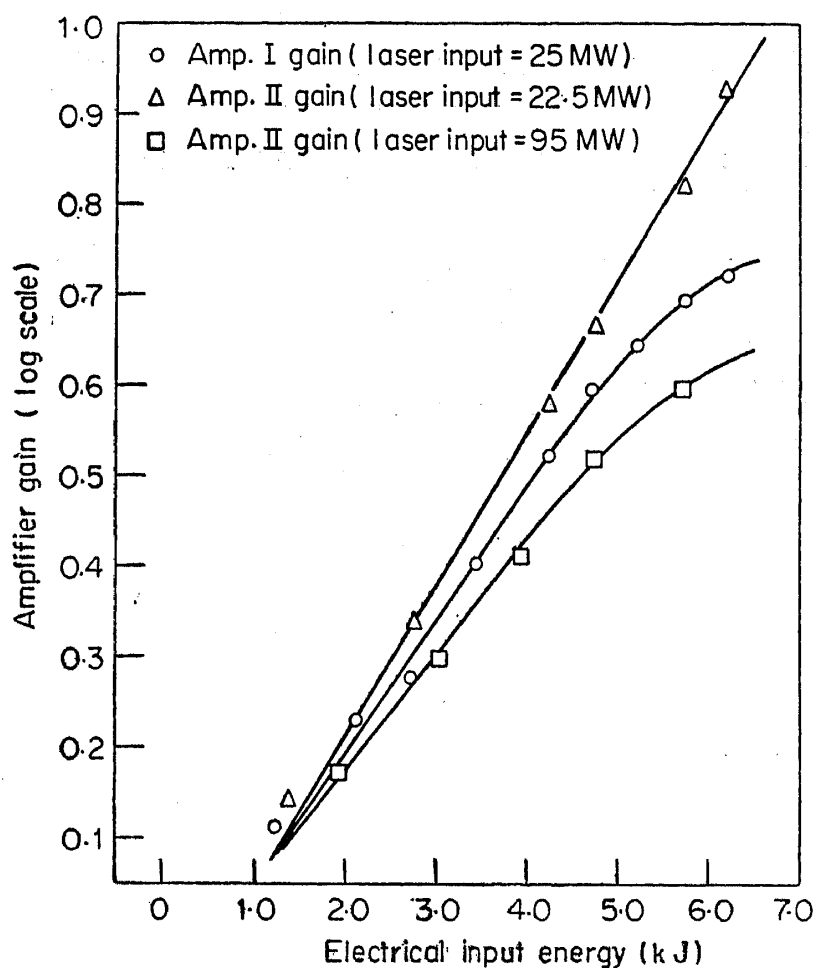

Figure 4. Gain characteristics of amplifiers

### 3. Conclusions

The performance characteristics of a Nd:glass laser system are discussed. The EOLM *Q*-switched oscillator gave peak powers of 25 MW in 18 nsec FWHM. The output power and pulse duration of the oscillator output were measured at different electrical inputs and good agreement was found with the theoretically expected behaviour. Gain characteristics of the amplifiers were obtained and saturation behaviour explained from stored energy consideration. The system gave output energies upto 8 J in pulse durations of 20 nsec giving peak powers of 400 MW in a multimode beam.

### Acknowledgements

The authors wish to acknowledge the assistance of Mr S Kumbhare and Mr K S Birdi.

## References

- Basov N G and Krokhin O N 1964 *J. Exp. Theor. Phys.* **46** 171
- Basov N G, Zeuv V S, Krinkov P C, Letokhov V S, Senatskit Yu-V and Chekalim S V 1968 *Sov. Phys. JETP* **54** 767
- Bhatnagar R, Gupta P D, Narayan B S, Anwar M, Gupta B L and Bhawalkar D D 1978 BARC Int. Rep. (to be published)
- Dawson J M 1964 *Phys. Fluids* **7** 981
- Grek B, Pepin H, Johnston T W, Leboeuf J N and Baldis H A 1977 *Nucl. Fusion* **17** 1165
- Hagen W 1969 *J. Appl. Phys.* **40** 511
- Kachen G I (ed.) 1971 Lawrence Livermore Laboratory Report UCRL-50021-71
- Ross D 1964 *Appl. Opt.* **3** 259
- Steele E L 1965 *J. Appl. Phys.* **9** 2442
- Wagner W G and Lengyel B A 1963 *J. Appl. Phys.* **34** 2040
- Walter Kuechner (ed.) 1976 *Solid State Laser Engineering* (New York: Springer-Verlag)