



Simpson, B., & Vardanega, P. J. (2014). Results of monitoring at the British library excavation. *Proceedings of the Institution of Civil Engineers: Geotechnical Engineering*, 167(2), 99-116. 10.1680/geng.13.00037

Link to published version (if available):
[10.1680/geng.13.00037](https://doi.org/10.1680/geng.13.00037)

[Link to publication record in Explore Bristol Research](#)
PDF-document

University of Bristol - Explore Bristol Research

General rights

This document is made available in accordance with publisher policies. Please cite only the published version using the reference above. Full terms of use are available:
<http://www.bristol.ac.uk/pure/about/ebr-terms.html>

Take down policy

Explore Bristol Research is a digital archive and the intention is that deposited content should not be removed. However, if you believe that this version of the work breaches copyright law please contact open-access@bristol.ac.uk and include the following information in your message:

- Your contact details
- Bibliographic details for the item, including a URL
- An outline of the nature of the complaint

On receipt of your message the Open Access Team will immediately investigate your claim, make an initial judgement of the validity of the claim and, where appropriate, withdraw the item in question from public view.

Results of monitoring at the British Library excavation

Brian Simpson OBE, FEng, MA, PhD, CEng, FICE
Arup Fellow, Ove Arup & Partners, London, UK

Paul J. Vardanega MEngSc, PhD, MIEAust, MASCE
Lecturer, Department of Civil Engineering, University of Bristol, UK;
formerly Research Associate, Department of Engineering, University of Cambridge, UK

The main phase of excavation for the basements of the British Library at St Pancras, London, was completed in 1987. The project included basements extending up to 25 m deep, through the London Clay and into the Lambeth Group. The excavations were formed using both the top-down method and open excavation with ground anchors. Existing major buildings lie within 25 m of the site and London Underground tunnels lie below and adjacent to the site. The purpose of this paper is to present the results of displacement monitoring; they are summarised in the paper and presented in more detail in online supplementary data files. The retaining walls advanced towards the site by up to about 32 mm and the clays expanded rapidly on unloading beneath the excavations, causing the Victoria Line tunnels to heave by up to 22 mm. The slow progress of the project provided an unusual opportunity to monitor ground and structure movements in the surroundings before site activity began. Ironically, it was found that the largest settlements of adjacent buildings were caused by the installation of equipment intended to measure the settlements. Extensive condition surveys were carried out, but no damage to adjacent structures or tunnels has been recorded.

1. Introduction

In 1972 a number of nationally important libraries were incorporated under one authority, the British Library Board. It was thought desirable to relocate these libraries on a single site in London and in 1975 a site adjacent to St Pancras station was selected. Design and construction of the building progressed slowly, regulated by the supply of public funds. The conception of the project is described in more detail by Ryalls and Stevens (1990), Stevens and Ryalls (1990) and by the architect, Colin St John Wilson (1998).

The British Library project was very significant in terms of the development of design and analysis of deep basements and embedded retaining walls. There was a large quantity of extensometer, inclinometer, tunnel monitoring and traditional survey measurements carried out at the time which has not received detailed review or back-analysis. The main purpose of this paper has been to make available the database of monitoring results from the British Library excavation.

This paper is concerned with the ground movements measured during construction of phase 1A of the Library. Later phases which were planned initially were substantially reduced, leaving only the 'completion phase' in the early 1990s. For phase 1A, the excavation was complete by 1987 and the structure was complete by 1989. The monitoring results are summarised in this paper and presented in more detail in the online supplementary material, which also includes detailed records of the sequence of excavation and construction. The appendix lists five online supplementary data files, referred to as W1, W2, W3, W4 and W5 in this paper.

1.1 The site

The site lies to the north side of Euston Road, immediately west of St Pancras station (Figure 1). To the west is Ossulston Street and, to the east, Midland Road. The width of frontage on Euston Road is 83 m. The width at the northern limit of construction, 150 m north of the Euston Road, is about 140 m. The level at the north-east corner of the site is 17.5 m OD (Ordnance Datum). Ground level falls roughly 2.5 m from the south-west to the north-east corner. Until 1972, the site was occupied by an old railway construction, the Somerstown goods depot, demolition of which left large brick masonry spread footings up to 4 m below ground level. St Pancras station, a listed building, lies to the east and St Pancras old town hall is on the south side of Euston Road. Both of these buildings were constructed in load-bearing brickwork. To the west of the site, across Ossulston Street, are a residential block and the Shaw theatre and library.

Railway tunnels of London Underground run adjacent to, and beneath, the site (Figures 1 and 2). The Metropolitan Line lies under Euston Road in tunnels originally constructed in 1863, and repaired after damage during World War II. The tunnels of the Victoria Line, in both precast concrete and cast-iron segments, lie roughly 120 m north of Euston Road with their crown at about 0.0 m OD. Fifty metres further north, and about 5 m deeper, the two tunnels of the Northern Line are formed in cast-iron segments. The north-east corner of the site is skirted by the brick masonry tunnels of the Midland Loop, an overground rail line.

1.2 Ground conditions

The stratigraphy at the site is shown in Figures 2 and 3. About 2 m of fill overlies the London Clay, which is about 18 m thick.

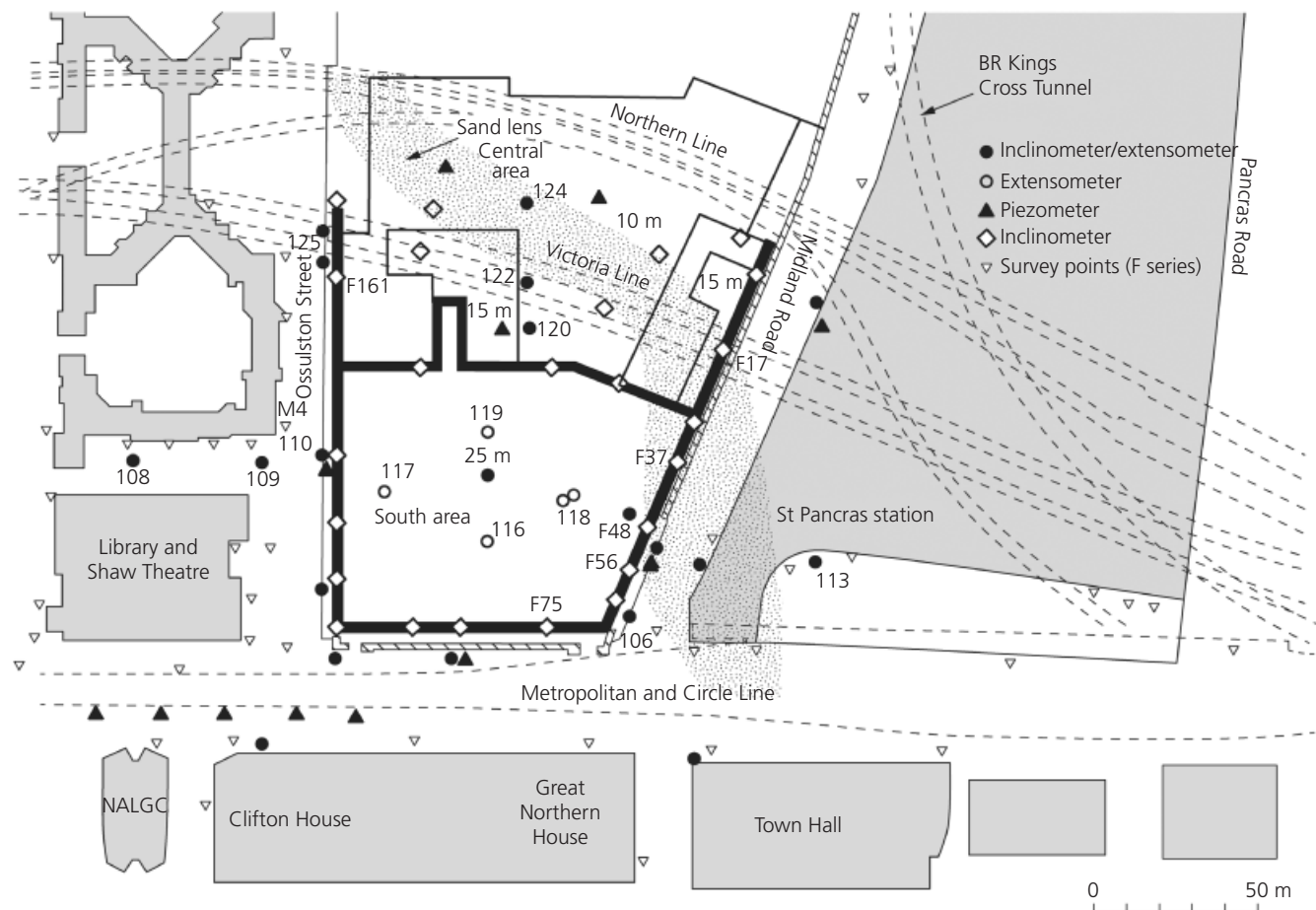

Figure 1. Location plan, including surrounding buildings and location of instruments

Below this lie 18 m of Lambeth Beds, which are generally clay in their upper 14 m, becoming very sandy below this. In the central area, a 2 m thick lens of sand in the Lambeth Beds intersects the Victoria Line tunnel and was also found in site investigation and instrumentation boreholes between -2.5 and -4.7 m OD. Its approximate location is shown in Figure 1. The beds of the Lambeth Group are underlain by 4 m of Thanet Sand, below which lies Upper Chalk at a depth of about 44 m.

Some results of the site investigation for the project and other testing carried out on the site were published by Simpson *et al.* (1981) and some analysis of the soil properties was undertaken in Vardanega *et al.* (2012a, 2012b). These include results of undrained triaxial tests, standard penetration tests, cone penetrometer tests and pressuremeter tests.

Very little free water was encountered in the fill overlying the clays, but water pressures measured in standpipe piezometers increased with depth below the clay surface (Simpson *et al.*, 1989; Vardanega *et al.*, 2012b). The Thanet Sands contained no

free water and a deep well sunk during construction identified a water table in the Chalk at -48.2 m OD in 1984, which had risen to -44.9 m OD by 1991 (and to -35.6 m OD by 2001, since when levels in the area of the site have been relatively stable). As a result of this under-drainage, the water pressures throughout the clays are sub-hydrostatic from the upper water table at the clay surface, roughly represented as 60% of hydrostatic. The sand lens in the central area, typically located between -2.3 and -4.6 m OD, contained water with a piezometric level of about $+5$ m OD.

1.3 The structure

The structure of the basements is shown in Figures 1–3. It is divided into a south area with four to five levels of basement and a central area with one to two levels. Retaining walls built of 1.1 m dia. secant piles surround the whole basement area.

The south area is about 25 m deep and was constructed using the top-down method, with a wall toe-in of about 4.5 m below the excavation. Its foundations consist of 1.8 m dia. bored piles, under-reamed up to 4.3 m dia. at the base of the Lambeth Beds.

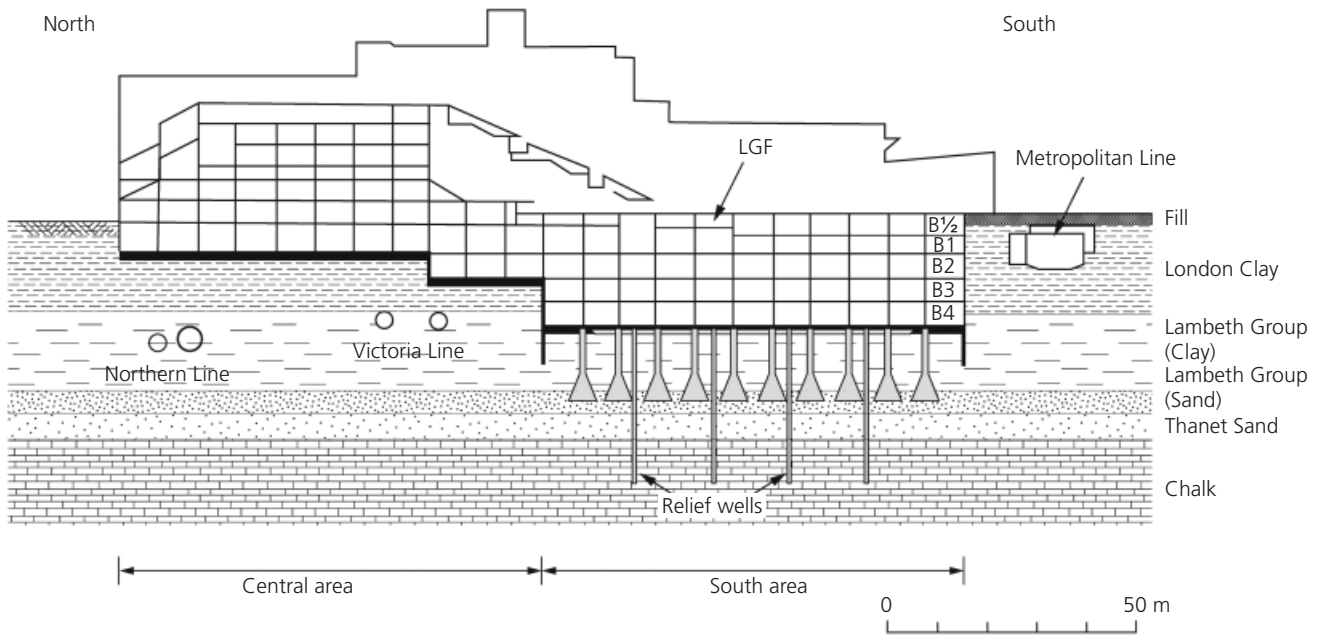

Figure 2. North–south section through the structure. (LGF, lower ground floor)

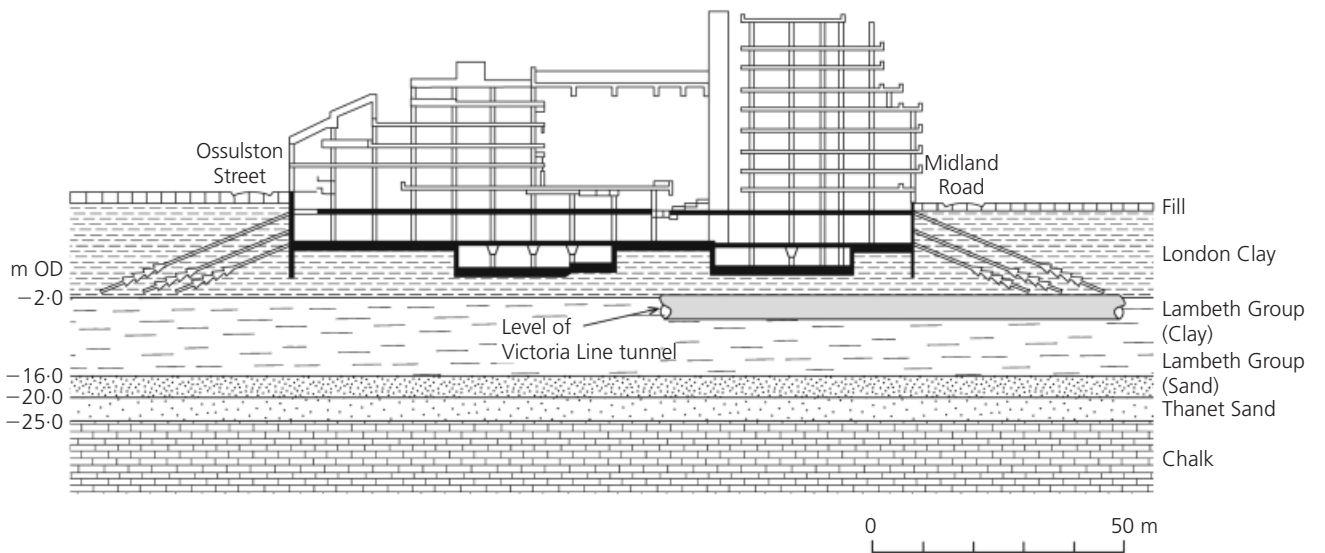

Figure 3. East–west section through the central area (looking north)

The piles were concreted up to the level of the lowest basements leaving cased shafts above, in which the columns were subsequently installed. The retaining walls are supported by the floor slabs that span across the site and are generally 400 mm thick.

The central area is up to 14 m deep and is underlain by tunnels of the Victoria Line, which made a piled foundation scheme inappropriate. This area was therefore founded on a raft and

constructed in open cut with retaining walls supported during excavation by ground anchors (more detail in Raison (1987a, 1987b)).

During construction of the basements, pressure relief wells were formed in both the south and central areas (see W5). In the south area, their main purpose is to ensure that, in the long term, water pressures in the aquifer beneath the site do not become high

enough to disrupt the foundations. In both areas the wells were designed to drain downwards to the Thanet Sands during the construction period, in order to prevent development of positive pore pressures in the clay beneath the excavation. In the central area, the relief wells were sealed by grouting at the end of construction.

2. Monitoring

2.1 General

The construction and subsequent behaviour of the excavation was monitored by measuring displacements, water pressures and structural strains. Displacements were measured using level and traverse surveys on the ground surface and in tunnels, inclinometers and magnet extensometers in boreholes and the basement walls, and rod extensometers to measure changes of dimensions in the tunnels. In addition to the standpipe piezometers used in the original site investigation, pneumatic piezometers were installed for monitoring purposes during the construction, but the results of these were not found to be meaningful. Similarly, strains were measured in concrete floor slabs but it has not proved possible to derive useful information from the results.

Much of this monitoring was started in 1979, 4 years before significant activity on the site. Precise locations for all the instruments are given in online supplementary data W1.

2.2 Surface surveys

Precise levelling and surveying were carried out around the site from 1979 by surveyors of the Directorate of Civil Accommodation of the Property Services Agency. The locations of the survey stations are shown in Figure 1. The tops of boreholes and wall inclinometers were also included in the surveys. Further details are given in online supplementary data W1 and W2.

2.3 Ground and structural instrumentation

In 1979, 24 strings of magnetic extensometers were installed in boreholes in the locations shown in Figure 1. These consisted of ring magnets located at nominal 3 m spacing on access tubes. Within the site and close to it, the extensometers generally extended to about 40 m below ground level; lengths of about 25 m were used further away.

In 20 of the boreholes, the access tubes were also used for inclinometers, whereas in the other four boreholes standard 25 mm tubing was used for the extensometers. Readings were taken from the inclinometers in two orthogonal directions, generally oriented to be approximately parallel and perpendicular to the plane of the nearest retaining wall. Over the years, various inclinometer torpedoes were used, taking readings at 1 m intervals. Twenty inclinometers were installed in the secant pile walls of the basement during their construction at the F-series locations shown in Figure 1.

2.4 Tunnels

In the tunnels of the Victoria and Northern Lines, deformations have been measured using level and traverse surveys, measurements of offsets from lines set up in the traverse surveys, and measurements of diameters. The tunnels of the Metropolitan and Circle Line vary in section along the length affected by the excavation. Deformations were measured by level and traverse surveys and by measuring across internal dimensions with an extensometer.

2.5 Reliability and accuracy

The reliability and accuracy of the instrumentation was discussed by Loxham *et al.* (1990). The reliability of some of the equipment and early readings was disappointing and so required careful filtering. Inclinometers in boreholes were particularly problematic, but confidence can be gained in some of the results by careful comparison of readings from different dates and correlation with survey results. Results presented in this paper are considered to be sufficiently accurate to provide useful engineering insight.

In contrast, the inclinometers in the walls showed much better repeatability. It is not reasonable, however, to assume that the bottoms of the walls do not move, so some means of fixing the absolute displacement of the walls is required. This has generally been based on the results of the traverse survey of the tops of the tubes. This started too late to pick up some of the movement due to initial excavation, so for this stage it was assumed that the bases of the walls were stationary.

3. Measured movement

3.1 Summary

The general trend of movements within and around the site followed a predictable pattern. Figure 4 shows a 'bird's eye view'

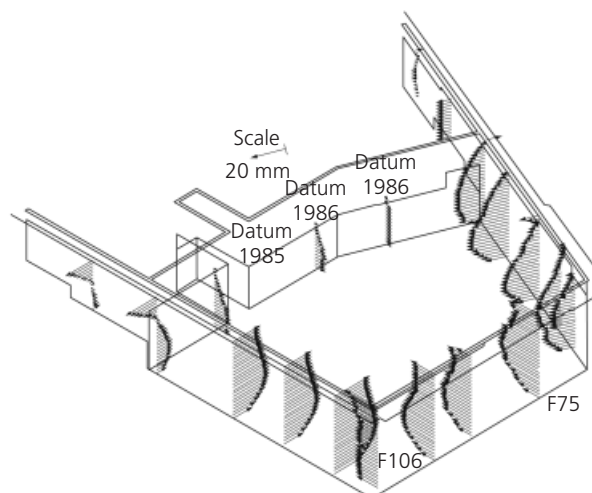

Figure 4. Wall displacements at end of excavation in 1987

of movements at the end of construction of the basements in 1987, indicating inward movements of the walls of up to 32 mm. The exceptional outward movement of the wall along Ossulston Street will be discussed later. Three inclinometers, marked on Figure 4, only became accessible after substantial excavation had taken place. Of the rest, only F75 and F106 (in a corner) were installed and read before the initial excavation of 5 m.

Settlements recorded around the site at the end of construction are shown as numbers in Figure 5, together with horizontal displacements shown as arrows. The settlements around borehole 109 are exceptional and will be discussed separately. The overall rotational movement of the ground towards the site can be seen in Figure 6, which also shows heave occurring beneath the excavations.

The development of the movements will now be discussed in more detail, considering separately: (a) the period that elapsed after installation of the instrumentation and before major activity on the site; (b) the stage of initial site clearance, wall and pile construction; (c) the main excavation and construction. The construction of the basements at the British Library was inevitably a very complex exercise and it is beyond the scope of this paper to describe it in detail. A brief account of the main features relevant to understanding the ground movements is given below.

3.2 Before excavation began on site

Much of the instrumentation was installed in 1979 and demolition of the Somerstown goods yard took place in the same year. Further work on site was delayed until 1982. This gave an unusual opportunity to study the reliability of the measurements

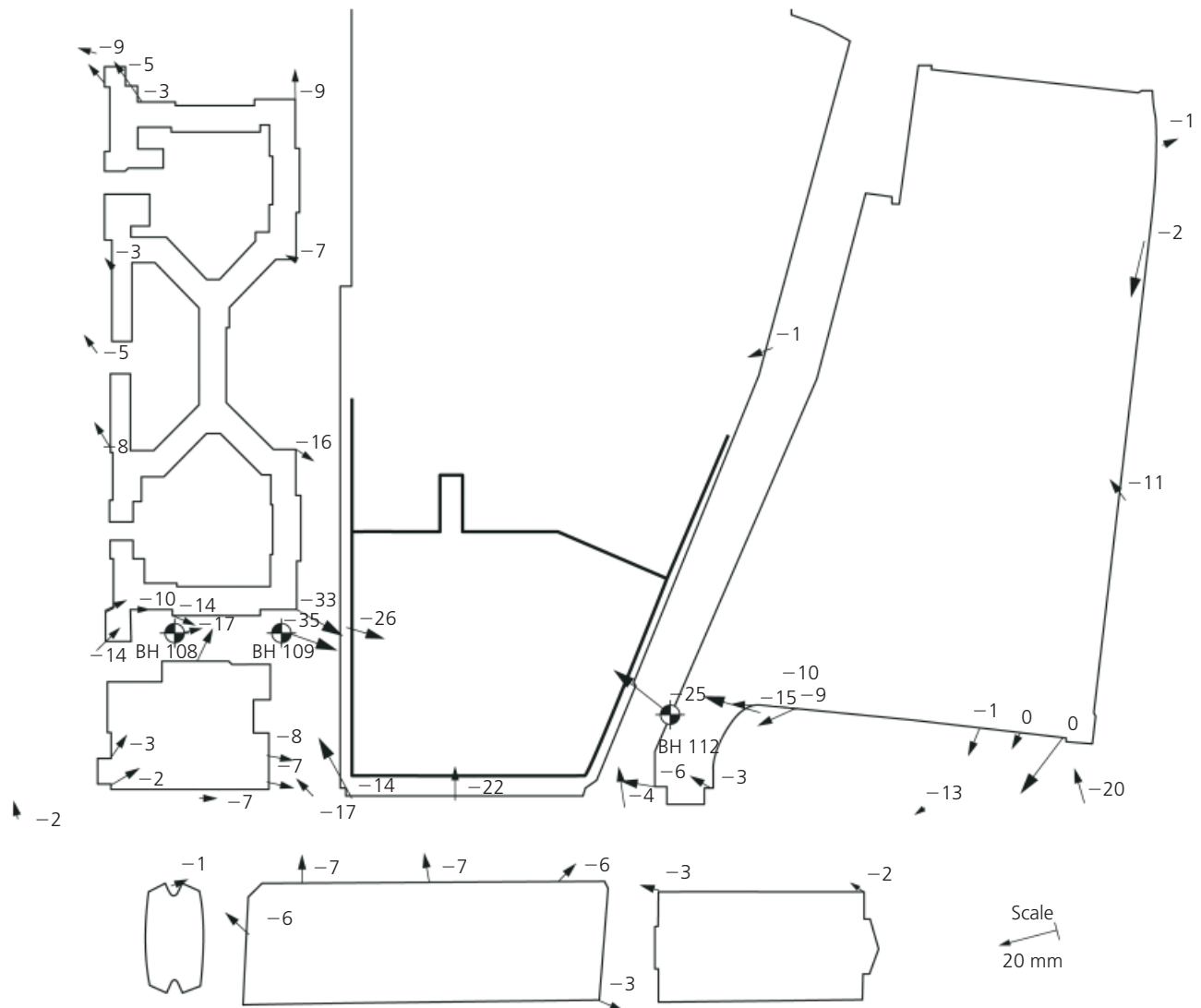

Figure 5. Displacement at ground surface to end of excavation in 1987. Numbers represent settlements in mm; arrows show displacements in plan

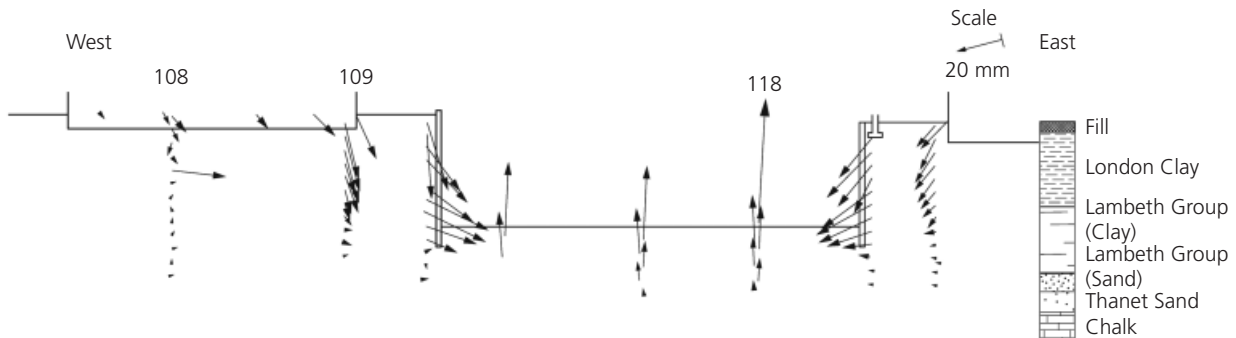

Figure 6. East–west section across south area, showing ground movements at end of excavation in 1987

and also to note movements that were taking place, not caused by site activity. The reasons for these were often unclear.

During this period, the survey reference points showed very little movement, with the exception of two concrete blocks situated over the Metropolitan Line tunnel. Some of the points on buildings showed more movement, notably around borehole 109. Settlements derived from level surveys for the tops of the boreholes and from the top magnets of the borehole extensometers over a longer period are shown in Figure 7; settlements of nearby wall marks are also shown. Overall, the extensometers show a similar pattern of settlement to that of the survey results, but with slightly less total settlement and some significant fluctuations, confirming the reliability of the extensometers.

In contrast, it became clear during the period before 1982 that the borehole inclinometers could only provide useful results if they were corrected by reference to the traverse survey. They did not provide any reliable measurement of the small ground movements before 1982.

3.3 The area around boreholes 108 and 109

Between 1979 and 1981 rates of settlement of up to about 5.5 mm/year were recorded by surface surveys and extensometers in two adjacent boreholes, 108 and 109 (Figure 5). Although this continued throughout the period of construction, it is noted here because it started before the main site works began.

Adjacent to these boreholes is a five-storey building constructed in the 1930s. On inspection, no damage to the structure was apparent and it was concluded that the building could not have been settling at this rate for much of the time since its construction. By 1981, no significant work had been carried out on the British Library site so some other cause of the settlement was sought. Local details of the history and geology of the site were considered, together with the histories of benchmarks in the area generally, but this study did not provide an explanation.

Figure 8 shows settlements recorded at a wall mark on the corner of the building, which had already reached 11 mm by

1981. By 1990 the total settlement of the south-east corner of the building adjacent to borehole 109 amounted to 38 mm and had apparently come to a halt. The settlement trough is extensive but very gentle, with maximum gradients of about 1/1800. This would not be expected to cause damage, and none was observed.

Settlements recorded by extensometer 109, up to October 1987, are shown in Figure 8, indicating that the settlement was due to compression extending to about 20 m depth.

Most of the ground instrumentation boreholes contained access tubes for either inclinometers or extensometers that extended through the stiff clays into the Thanet Sands, in which there was no free water. The boreholes were backfilled with cement–bentonite grout, but it was found that if water was poured from buckets down the inclinometer tube in borehole 109 it was not possible to fill it up. It therefore seemed likely that borehole 109 acted as a drain through the London Clay and the Lambeth Beds, relieving water pressure and so causing consolidation.

Referring to Figure 5, it is possible that borehole 108 also contributed to the problem and that a similar but less marked problem may have occurred around borehole 112. If the explanation of the settlement given above is correct, it is ironic to note that the largest settlements of adjacent buildings recorded on this project were caused, not by the excavation, but by the installation of equipment intended to measure the settlements. On a more typical project in which instrumentation is not established significantly before the start of site works, these observations may well have been misinterpreted to be caused by the excavation.

3.4 Initial excavation, and construction of walls and piles

3.4.1 Site activities

The first phase of excavation, carried out between April 1982 and May 1983, was required to remove old foundations which would have constituted an obstruction to pile construction. The secant

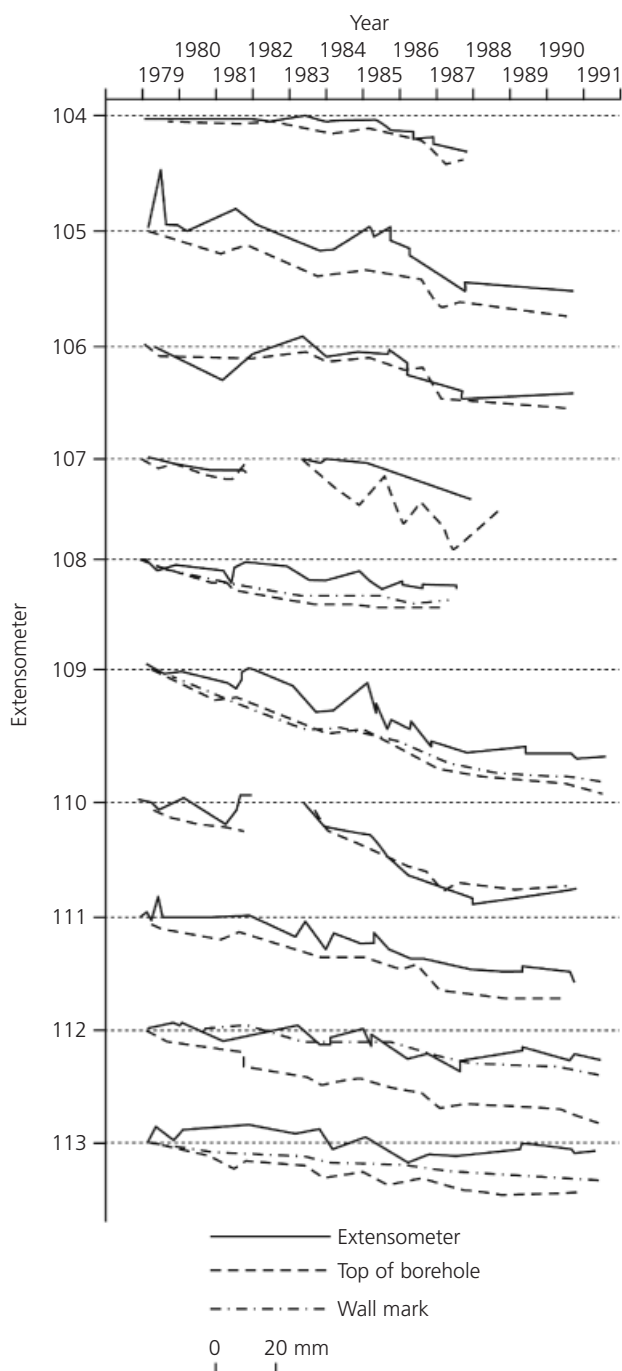

Figure 7. Settlement at ground level around the site at end of excavation in 1987

pile walls were constructed during the same period. The levels on the site at the end of 1983 are shown in Figure 9(a). A description of the site activities at this early stage is provided in *Ground Engineering* (1984).

The under-reamed piles for foundations were constructed between June and September 1983. These piles were concreted up to a level of -5 m OD and the shafts above were held open by

'Armco' corrugated casings surrounded by an annulus of pea gravel. The steel columns for the structure were subsequently placed in the shafts and surrounded by pea gravel to give them temporary stability under vertical load.

3.4.2 Ground displacements

Displacements measured between 1982 and 1984 are shown in Figures 10 and 11. The surrounding ground generally moved towards the site by up to about 10 mm and settled by up to about 5 mm, with larger settlements around borehole 109.

Inclinometer F75, on the south wall of the site (Figure 1), was one of the earliest wall inclinometers to be commissioned and was in an area where nearby excavation took place at a late stage. Detailed results for this inclinometer are shown in Figure 12, from which the following points may be drawn.

- (a) By the end of February 1983, general excavation on the site was not very far advanced. However, in January 1983 a 10 m wide trench had been excavated in front of the wall at the location of F75 to the full depth of the initial excavation, about 5 m. The inclinometer readings indicate that this may have caused the wall to move forward about 2 mm, with an additional rotation of about 8 mm over the top 3 m. This form of movement at the top of the wall is considered unlikely and has been eliminated from readings shown in this paper.
- (b) By the end of April 1983, the immediate effect of excavation was a forward rotation of the wall of about 9 mm. This increased by a further 7 mm by February 1984, which includes the period of under-reamed pile construction, ending September 1983.

3.4.3 Extensometers

Figure 13 shows results from extensometers within the site, for 4 to 6 m of excavation (Figure 9(a)). Up to 1984, the results for the central area and south area are strikingly different. It is probably significant that at inclinometers 120, 122 and 124 excavation took place before November 1982 and part of the excavation was under water during much of the winter. It appears that the London Clay was swelling to a depth of almost 20 m below excavation level, even in this relatively short period. At the extensometers in the south area, excavation took place in March to May 1983 and was followed in June to September by construction of the under-reamed piles. It is possible that the effects of constructing the piles, including any loss of ground and the effects of the drains provided by the shafts, cancelled the heave that would otherwise have been caused by this initial excavation. Nevertheless, vertical expansion of up to 15 mm is indicated for the top 10 m or so of the clay in this area.

3.5 Effect of installation of under-reamed piles

The under-reamed piling was constructed between June and September 1983. Figure 14 shows the displacement recorded by wall inclinometers and extensometers within the site between

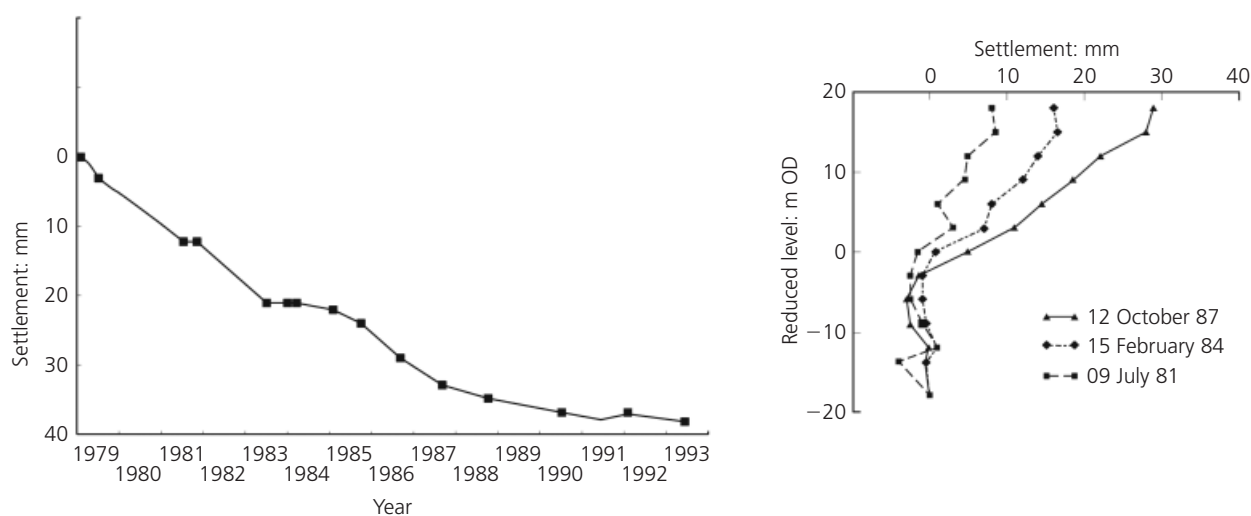

Figure 8. X18B Settlements recorded (a) at wall mark M4 on the adjacent building and (b) by extensometer 109 from early 1979

May 1983 and early 1984. During this period, the site could still have been reacting to the effects of the initial excavation in 1982. These plots assume that the bases of the inclinometer tubes, at the bottoms of the walls, did not move during this period, an assumption supported by negligibly small movements recorded at depth during the same period by inclinometers immediately outside the walls.

The dates of the available data make it difficult to draw conclusions about the movement caused by pile construction alone. The extensometers within the site show that settlements were very small during this period, much less than the 24 mm recorded by Burland and Hancock (1977) during under-reaming in the London Clay at the New Palace Yard site. Figure 14 suggests that the piling may have been responsible for an inward rotation of the walls in the region of 10 mm. As noted by Simpson (1992), this would be equivalent to around 1% of the total area of the piles in plan, similar in magnitude to ground loss due to tunnelling. However, the inward movement tapers towards zero at the bottom of the walls.

3.6 Main excavation in the south area

3.6.1 Excavation and construction

The south area was designed as a 'top-down' construction. The complete sequence of excavation and strutting is given in online supplementary data W5. The state of the site part way through the works is shown in Figure 9.

At each level, excavation was taken to about 0.6 m below the required soffit level of the slab and the clay surface was blinded with concrete. The slab was then constructed on removable formwork which was required to be released within 4 weeks of casting to provide a void beneath each slab. This proved to be a wise specification in view of the very rapid heave noted at some

stages on the site since the slabs and column seats would have been very intolerant to upward movement or pressure.

The method of support provided to the walls of the north and south halves of the south area differed at the upper level of the basement, as can be seen in Figure 2. In the south half the 'B₂¹' slab supported the east and west sides of the site by direct thrust, but had no restraint on its northern edge. It therefore had to support the south side of the site by plate action, spanning across from east to west. Further north, the lower ground floor (LGF) slab was at a slightly higher level and supported the east and west sides by direct thrust.

The propping action of each floor level was required to be complete before excavation was allowed beneath it. Generally spoil was removed through access holes in the higher slabs. Excavation beneath the B1 slab in the south area was not allowed until completion of the B1 slab in the central area, thus providing a complete north-south prop at that level.

At levels B2 to B4 the slabs supported all four sides of the basement, so forces were balanced. At levels B2 and B3, excavation was complete over most of the south area before the slab was cast. However, at level B4 a more restrictive sequence of excavation and construction was used in order to minimise ground movements. Excavation to -5.4 m OD was carried out first in the centre of the area, leaving a berm about 10 m wide round the perimeter. The berm was then removed in lengths near the mid-sides of each of the four walls and a roughly cruciform section of slab was cast as shown in Figure 9(e). The intention of this procedure was that no long lengths of wall would be left unsupported at B4 level. The wall penetrated about 4.6 m beneath the excavation level at this stage. The berms were then removed in stages towards the corners of the area and the slab was cast in

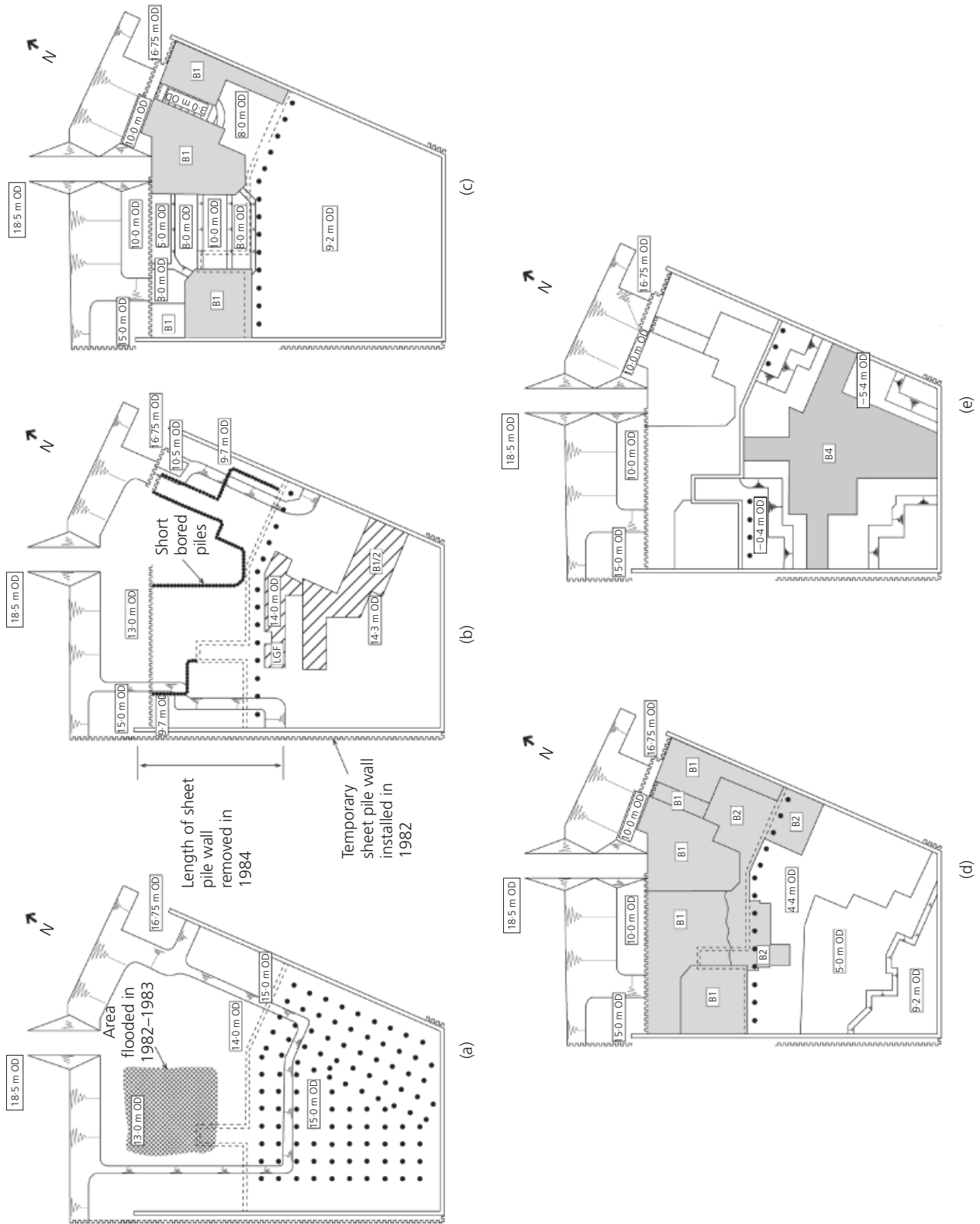

Figure 9. The site showing levels of excavation: (a) end of 1983; (b) December 1984; (c) July 1985; (d) February 1986; (e) April 1987. Slabs over excavation omitted for clarity in south area

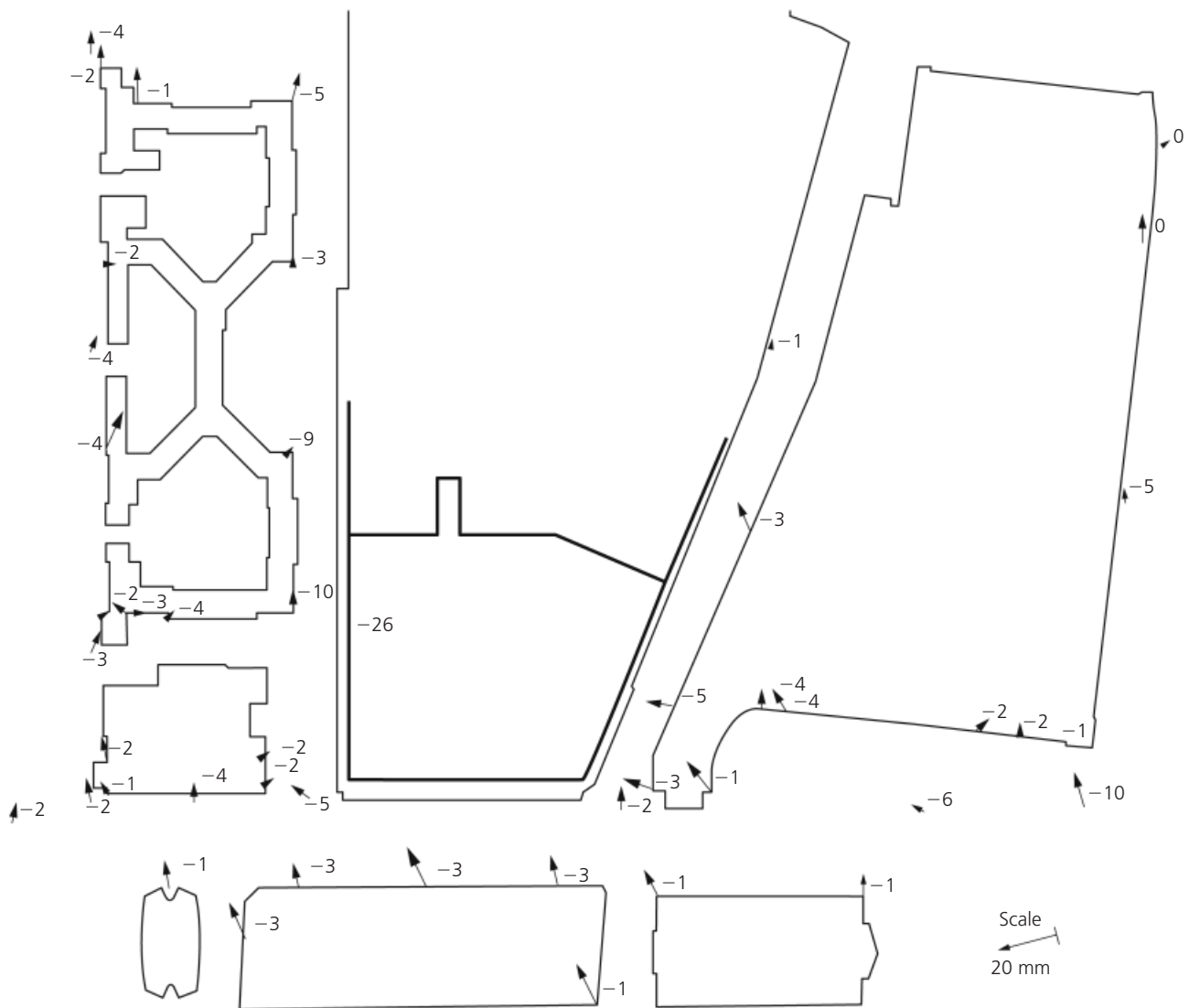

Figure 10. Displacement at ground surface between 1982 and 1984. Numbers represent settlements in mm; arrows show displacements in plan

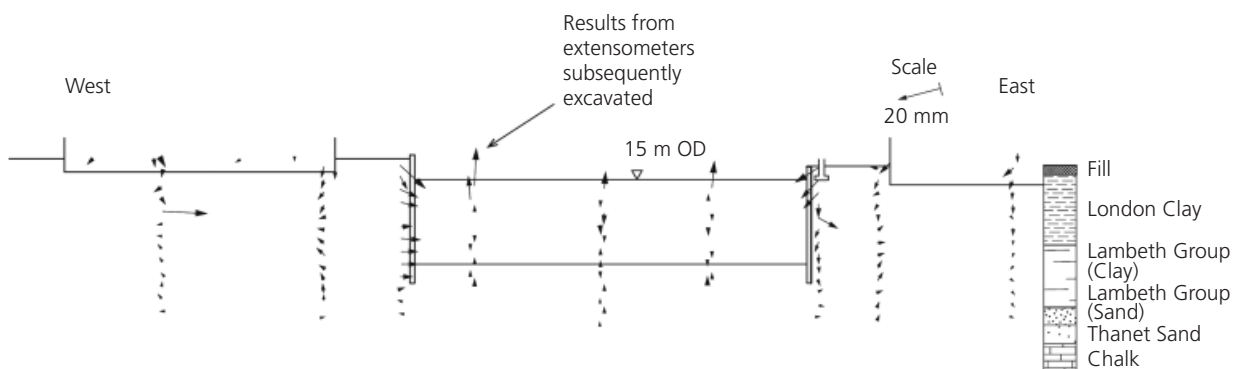

Figure 11. East-west section through the south area showing displacements 1982 to 1984

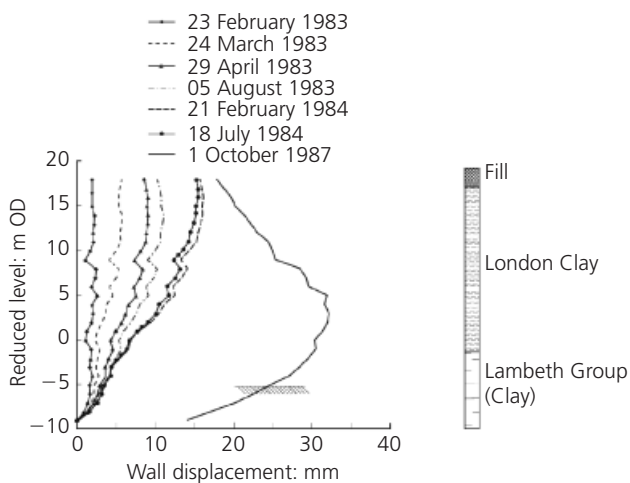

Figure 12. Inclinometer F75

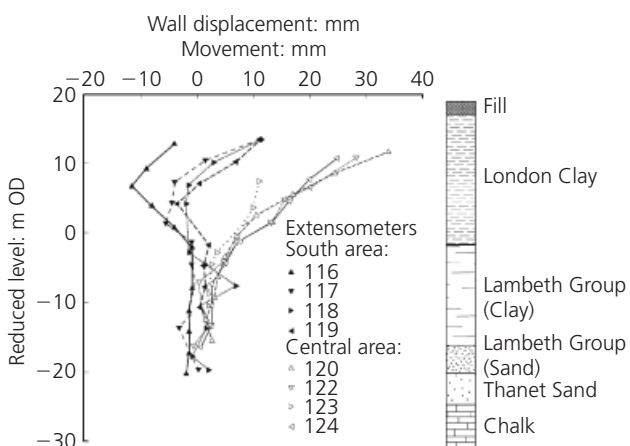

Figure 13. Results of extensometers in south and central areas, January 1979 to September 1984

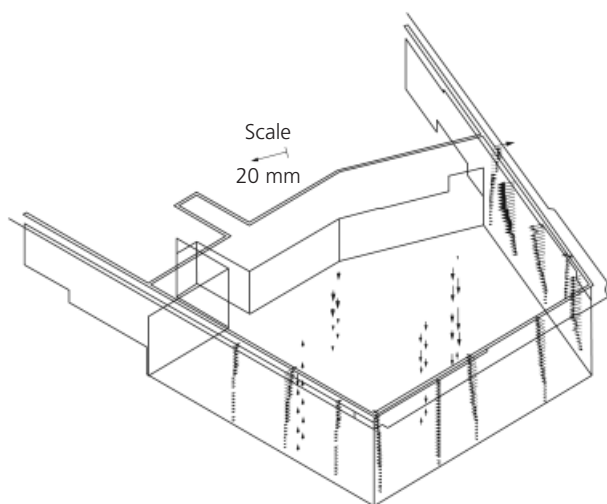

Figure 14. Results from wall inclinometers and extensometers within the site, May 1983 to early 1984

bays to provide support as rapidly as possible. The B4 slab was generally suspended but had a 5 m wide section of ground-bearing raft around the perimeter to enhance the passive pressure providing permanent support to the walls.

3.6.2 Ground movements around the south area

The displacements recorded up to the end of construction of the basement in 1987 are summarised in Figures 4 and 5. The development of the wall movements is shown in more detail in Figure 15. It was noted earlier that some movement may have taken place before many of the wall inclinometers became available. It can be seen that the largest displacement was recorded by inclinometer F75, which was available for reading at an early date when it was still well clear of any excavation. At the end of construction this inclinometer showed a maximum displacement of 32 mm with a toe displacement of 13 mm, as shown in Figure 12.

Figure 15 shows that maximum wall displacements in the south area were generally just over 30 mm. Most of this displacement was in the form of translation; bending and rotation accounted for about 10 to 15 mm. The toes of the walls moved inwards by up to about 20 mm. The measured displacements are remarkably uniform around the area and seem to vary little with distance from the corners of the excavation.

Figures 6 and 16 show displacements measured at the end of construction on planes normal to the walls near their mid-points. The results from the borehole inclinometers, after correction on the basis of the surface survey, show a credible pattern of movement which is consistent in magnitude with the results from the wall inclinometers and from the survey in the Metropolitan Line tunnel. This consistency suggests that despite the difficulties in interpreting each type of measurement taken separately the results presented here are fairly reliable.

Horizontal and vertical displacements recorded around the site at ground level are shown in Figure 5. Although there are some anomalous results, probably where there has been movement for reasons not connected to the excavation, there is a general pattern of movement towards the excavation by amounts up to about 20 mm. Settlements within about 20 m of the excavation are of similar magnitude; settlements greater than about 20 mm were probably not caused by the excavation alone. The special case of the area around borehole 109 was discussed earlier.

3.6.3 Settlements recorded by extensometers

Figure 7 shows vertical movements of the tops of boreholes close to the site, comparing measurements made using the borehole extensometers and surface level survey. Where possible, the results of level surveys on nearby wall marks have also been added. All these results show settlement at the tops of all the boreholes and there is reasonable correspondence between the various measurements. More settlement is recorded near the mid-sides of the excavation than near the corners.

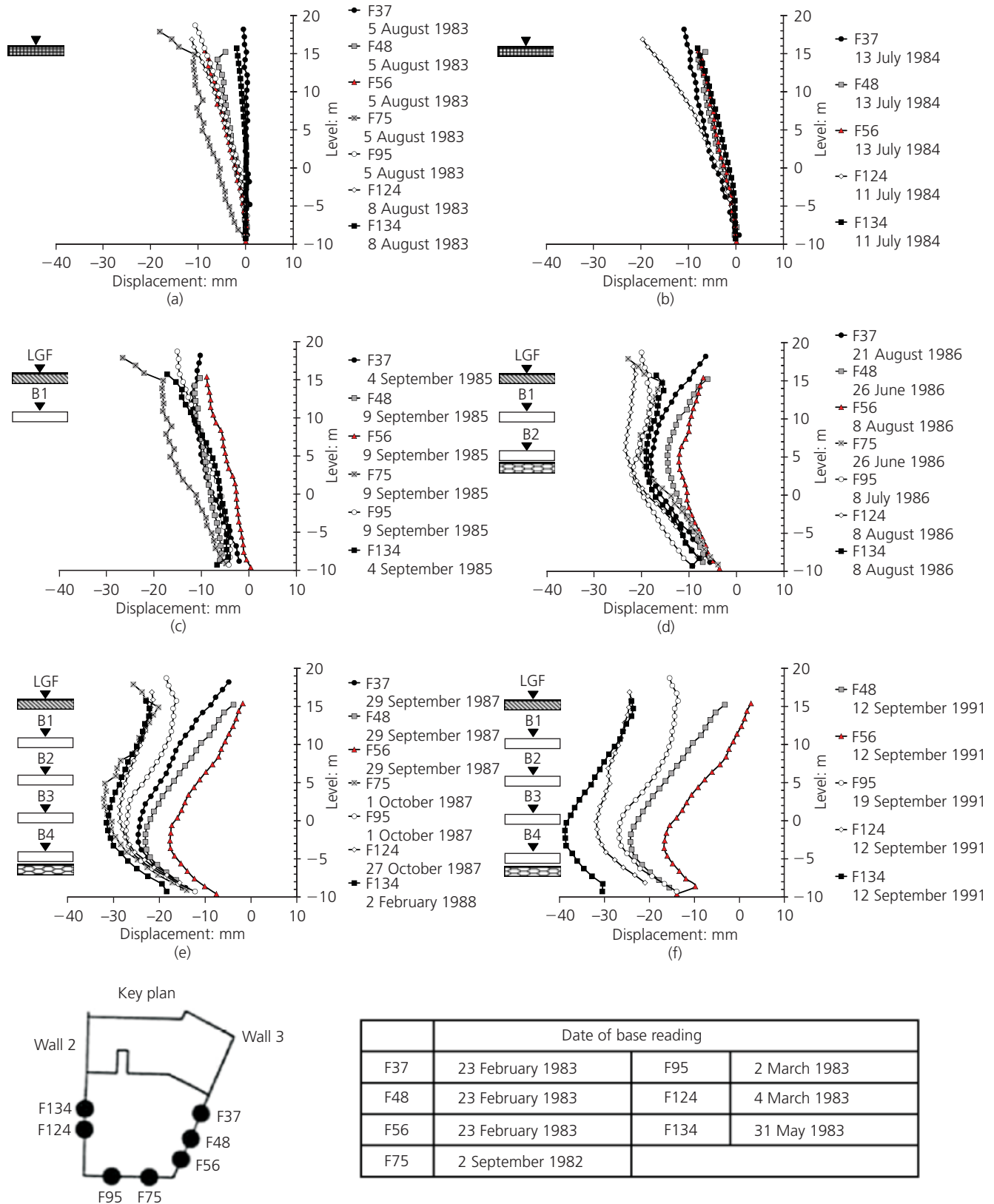

Figure 15. Development of wall movement – south area

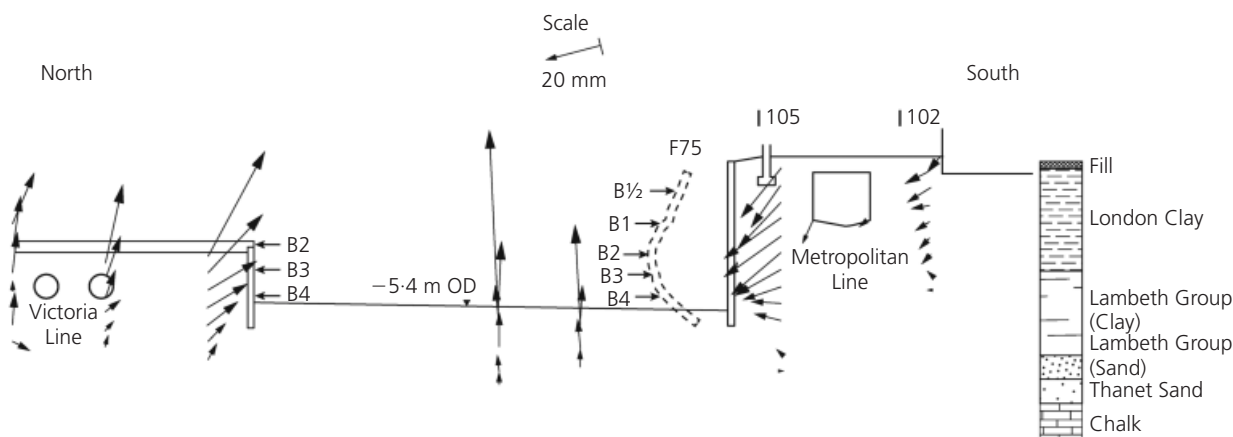

Figure 16. North-south section showing ground displacements at the end of excavation in 1987

The level surveys generally show more settlement at the boreholes than is indicated by the extensometers. This may be due to the fact that the level surveys record displacement at the tops of the extensometer access tubes, at ground level, whereas the top magnets of the extensometers are generally between 0.5 and 2 m below ground level. This explanation is supported to some extent by the observation that, at boreholes 112 and 113, wall marks on the adjacent walls of St Pancras station settled less than indicated for the boreholes by the level survey but more than indicated by the extensometers. At borehole 109, level survey results for the borehole and for wall marks M4 and M37, 9.5 m and 11.2 m away, respectively, showed very similar results and the settlement recorded by the extensometer was only slightly less.

With the exception of 110, all the extensometers included in Figure 7 had their lowest magnets at levels between -17.4 mOD and -18.5 mOD, that is, just above the Thanet Sands. Within the south area there was a net removal of overburden equivalent to about 420 kPa, which could have caused heave of the underlying Thanet Sands and Chalk. Around the perimeter of the site, the Thanet Sands would not be affected but the Chalk would experience reduction in stress to considerable depth. If this had caused measurable heave, the apparent settlement recorded by the extensometers would have exceeded that measured by level surveys. The fact that this was not the case indicates that, at the perimeter of the site, the heave of the Chalk was very small.

This finding has two implications. First, it shows that the bottom magnets of extensometers within the site are unlikely to have moved significantly and can be used as datum for other measurements. Second, it implies a very high stiffness in unloading for the Chalk. For extensometers on the perimeter of the site, elastic analysis for a 100 m thick stratum shows that heaves of 2 mm and 4 mm at the bottom magnets would have indicated Young's moduli of about 6 GPa and 3 GPa, respectively. Since it is unlikely that the heaves were as large as this, it appears that the stiffness of the Chalk is at least at the top of the range, up to

about 4 GPa, quoted for loading of Upper Chalk by Lord *et al.* (1994).

3.6.4 Heave recorded by extensometers

Figure 1 shows the locations of boreholes 116 to 119 in the south area and results from extensometers in these boreholes are shown in Figures 17 and 18. It was noted above that, in contrast to locations in the central area, none of these extensometers showed significant heave in response to the initial excavation of 5 m in 1982/1983. Heave was recorded, however, as soon as the main excavation started in late 1984. It is not clear why removal of 5 m of overburden in 1982/1983 caused no heave but removal of a further 0.7 m, only, in 1984/1985 apparently triggered rapid heave.

Figure 17 shows the heave recorded by all the magnets in extensometer 117. As excavation proceeded, magnets of the extensometer strings were dug out. Figure 18 shows the maximum heaves recorded at each of the magnets. In some cases, less than 3 m of overburden would have remained at the time of these readings, but more in other cases. For excavation depths between about 10 m and 25 m, magnets near the excavated surface heaved about 40–60 mm in both the London Clay and in the Lambeth Beds.

Reference to results such as shown in Figure 17 suggests that at any one time most of the heave is concentrated in the top 4 m or so beneath the current excavation level. Taking 40 mm over 4 m yields a vertical expansion of the clay of 1%, which corresponds for the whole excavation to a volume of about 1540 m^3 ($1\% \times 20 \text{ m} \times 7700 \text{ m}^2$). The average inward movement of the walls did not exceed 20 mm, which would give a volume of inward movement of 178 m^3 ($20 \text{ mm} \times 355 \text{ m} \times 25 \text{ m}$). Therefore, much of the vertical extension and heave must be accounted for by volumetric expansion of the London Clay and Lambeth Beds. During the period when this took place, the surface of the clay was almost completely protected from ingress of water, the site was surrounded by the secant pile wall which has very few

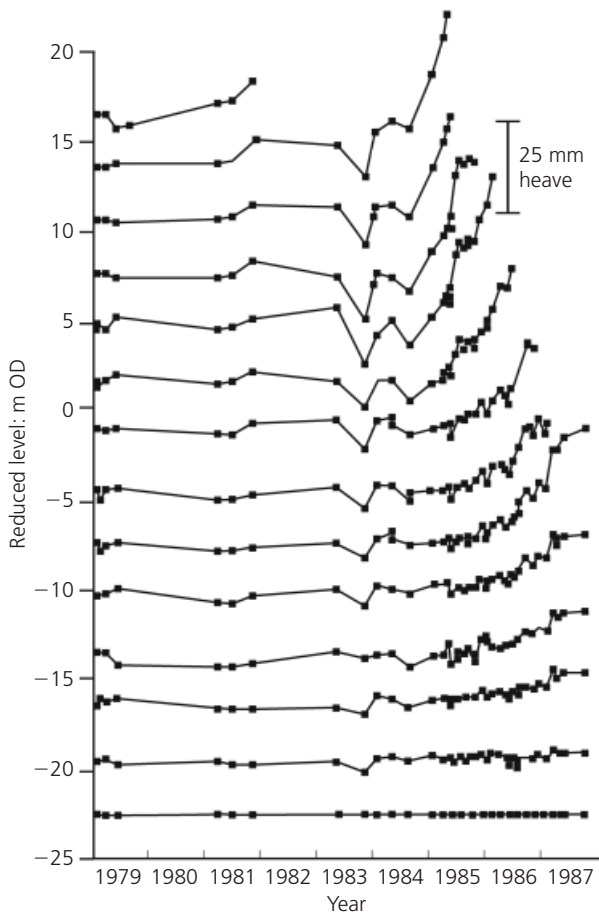

Figure 17. Extensometer 117 in the south area

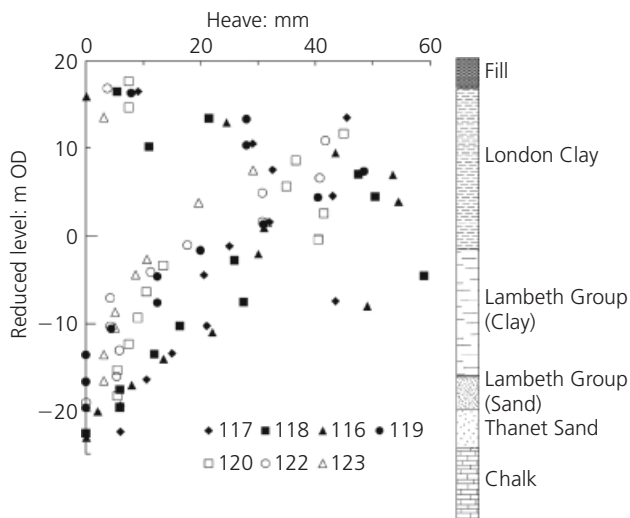

Figure 18. Maximum heaves recorded by extensometers in the south area (solid symbols – maximum excavation to -5.4 m OD) and central area (open symbols – maximum excavation to $+2$ m OD or $+5$ m OD)

leakages and the clay was underlain by Thanet Sands, which contain no free water. It is therefore most unlikely that the clay expanded by drawing in water and increasing its water content. Such ‘undrained expansion’ could only take place by processes such as cavitation or opening of fissures which could allow air to penetrate from the excavated surface.

3.7 Main excavation in the central area

3.7.1 Excavation and construction

The central area straddles the tunnels of the Victoria and Northern Lines. This made it impractical to use piled foundations and so a raft was adopted, stepping between the B1 and B2 levels. Consequently it was not possible to adopt a top-down construction procedure and the area was designed as an open excavation with the east and west sides supported by ground anchors. The state of the site during excavation can be seen in Figure 9.

As in the south area, the central area was excavated to a depth of about 5 m between April 1982 and May 1983 to remove existing foundations. Along the west side of the site the new secant pile wall was to follow the same line as the existing masonry wall which had foundations about 4 m deep. In order to remove the old wall it was necessary to install a temporary sheet pile wall outside the site; this was done in June 1982 in the location shown on Figure 9(b). During August and September 1984, the length of this sheet piling adjacent to the central area was withdrawn to facilitate installation of ground anchors.

The secant pile walls for the central area were constructed during 1982 and 1983, and ground anchor trials were carried out in April/May 1984. In July/August 1984 rows of short bored piles were constructed, as shown in Figure 9(b), which were to form the walls connecting the raft between B1 and B2 levels, cantilevering down from the B1 raft to provide support for the excavations for B2.

Between July and September 1984 pressure relief wells were installed in the central area (locations are shown in online supplementary data W5). The purpose of these was to limit the heave of the Victoria Line by ensuring that positive pore-water pressures would not occur in the clay beneath it. The wells were designed to drain downwards into the Thanet Sands.

3.7.2 Ground movements

The main features of the pattern of ground movements in the central area can be seen in Figure 19. The ground below the excavation, including the Victoria Line, heaved and buildings across the road from the site to east and west settled slightly and moved towards the site. Surprisingly, the retaining walls appear to have bent outwards, especially along Ossulston Street.

The initial earth pressures in the London Clay were considered in the site investigation. It was concluded that the vertical effective stress could be represented as increasing linearly with depth at a gradient of 14 kPa/m (due to under-drainage). Relative to this,

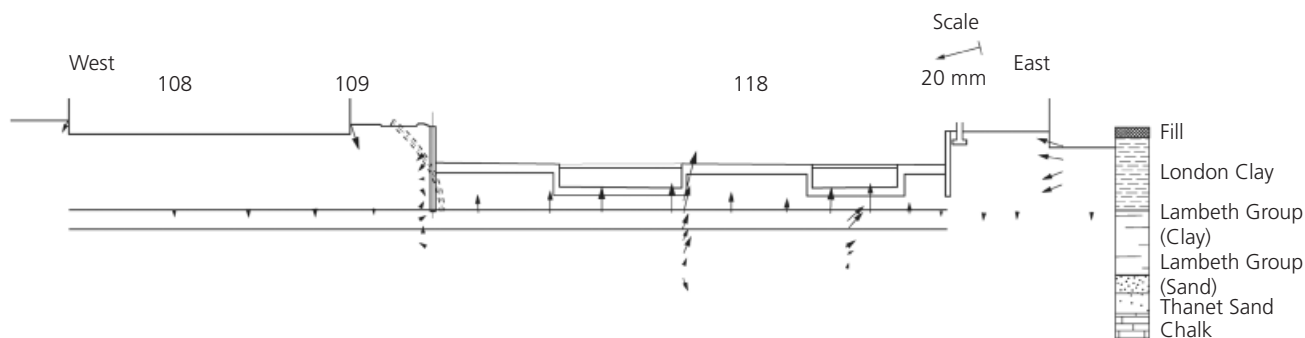

Figure 19. East-west section across central area, showing ground movements at end of excavation in 1987

the horizontal effective stress could be represented by a coefficient of earth pressure K_0 of 1.8. The data supporting this were published by Simpson *et al.* (1981).

The ground anchors were designed on the assumption that some relaxation of horizontal stress was tolerable, indeed unavoidable, and they were intended to balance an equivalent coefficient of earth pressure of 1.0. In the event, due to rounding up at various stages in the design and the practice of leaving the anchors stressed above their design loads, the total anchor force corresponded to a coefficient of about 1.3.

On Ossulston Street temporary sheet piling had been used to retain the street when the foundations of the old wall were removed. The northern portion of this was removed after construction of the secant pile wall, shortly before the anchors were installed. Extraction of the Frodingham 5 sheet piles left a zone of loose, disturbed soil behind the secant pile wall. Thus, when the anchorages were stressed the wall was bent backwards as shown in Figure 19. This resulted in the most severe wall curvature observed on the site.

It is notable, however, that inclinometer 125, about 2 m away from the wall and beyond the disturbed zone, also moved about 15 mm away from the site as the two lower rows of anchorages were stressed. On the east side there was no sheet piling but the wall moved away from the site as the anchorages were stressed, as shown in Figure 20 for inclinometer F17 at level 15.5 m OD. The walls on the east of the site subsequently moved back towards the site. The buildings across the roads from the site were largely beyond the fixed lengths of the anchorages and these moved towards the site at all stages. Noting that there is little evidence of measurable movement of the ground during construction of the walls, these data may indicate that the initial coefficient of earth pressure was less than 1.3.

3.7.3 Heave in the central area

The heave of the clay beneath the central area at the end of excavation can be seen in Figure 19. The heave of the northbound Victoria Line tunnel is also included on this figure and can be seen to be consistent with the extensometer results. As discussed

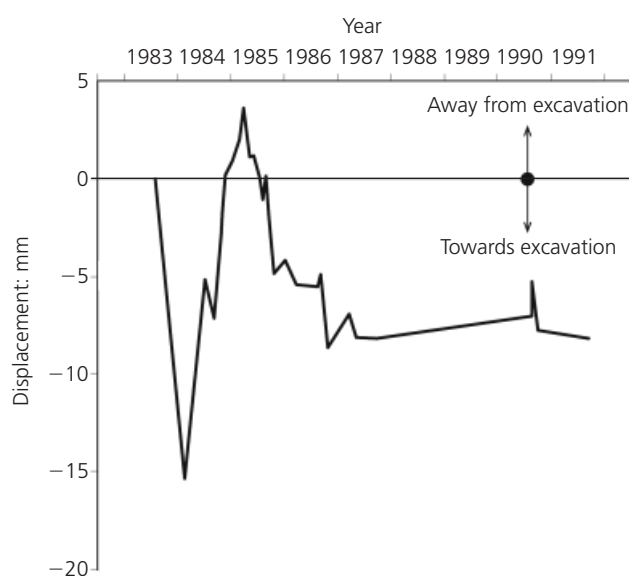

Figure 20. Displacement of the east wall at inclinometer F17, level 15.5 m OD

by Raison (1988), it is obvious from this cross-section that the clay exhibited volumetric expansion.

Figure 21 shows the heave recorded in extensometers 120 and 122, which are typical of others in the central area. It is notable that heave occurred rapidly as excavation took place and then stopped abruptly. Comparison of Figures 21, 18 and 17 shows that the amounts of heave recorded in the central area were similar to those of the south area.

In the central area, the excavated surface was exposed and rainwater could penetrate the clay. Part of the western half of the area was under water during the winter of 1982/1983 at a level of 14 m OD. It is therefore possible that the swelling of the clay was associated with increase of water content. The abrupt end to the heave might be caused by the placing of the concrete raft which would reload the clay to a small extent and would also cut off the supply of water from the surface. Nevertheless, in view of the

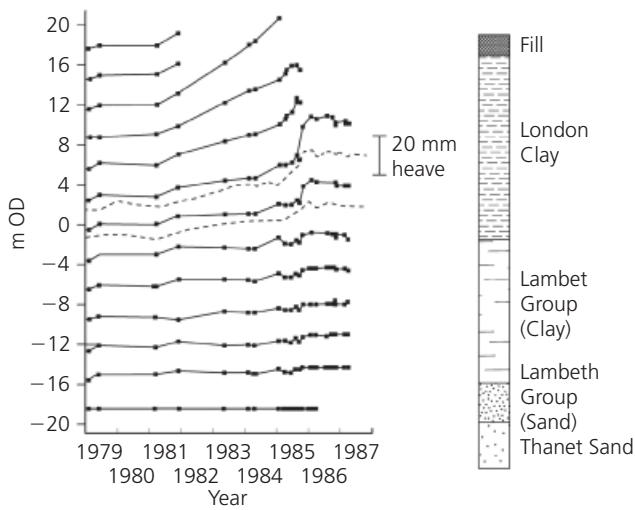

Figure 21. Extensometers 120 (solid lines) and 122 (broken lines)

conclusions drawn for the south area it is possible that the similar amounts of swelling in the central area were also caused by cavitation and ingress of air on fissures, rather than increase of water content.

3.8 Measurements for the underground tunnels

The database contains extensive sets of measurements of displacement and distortion for the underground tunnels. A brief account of the heave and distortion of the Victoria Line tunnels was given by Loxham *et al.* (1990), from which Figure 22 is reproduced. A maximum of 22 mm was recorded in late 1985, which reduced thereafter. This was accompanied by a maximum change of diameter of 11 mm. The maximum displacement of the Northern Line was of the order of 2 mm, too small to measure with confidence. Similar data were published by Raison (1988), who also discussed the rapid development of heave as the excavation proceeded, showing a correlation between the tunnel displacement and results of extensometers.

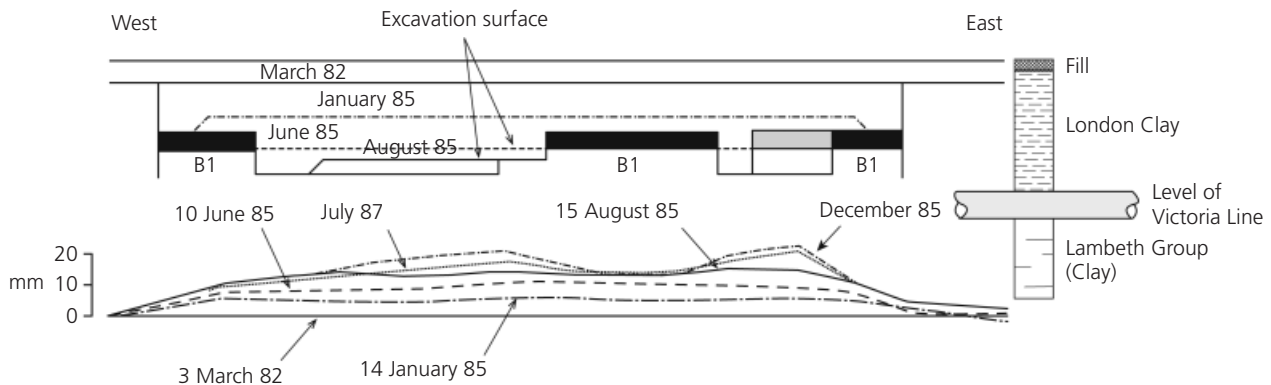

Figure 22. Development of heave for the northbound Victoria Line tunnel (after Loxham *et al.*, 1990)

Figure 23 shows contours of the settlement recorded by late 1988 in the tunnels of the Metropolitan and Circle Line. The tunnels extend from about +10.0 m OD to +17.0 m OD, with the tracks at about +12.0 m OD. During the period of excavation, these tunnels settled by up to 19 mm and moved north by up to 17.5 mm. Figure 24 shows the final displacements measured at cross-sections 608 and 611.

During the initial excavation in 1982, movement north was recorded, together with settlement of up to 7 mm (Figure 24(c)). However, during 1983 there was no excavation near this wall and much of the settlement of the Metropolitan Line seems to have recovered. As the excavation proceeded and the retaining walls moved further inwards, additional settlement took place and this was not recovered.

This tunnel is a large, old structure, deep enough in the ground to be unaffected by traffic or seasonal effects. The recovery of settlement during 1983 is therefore significant and suggests that the London Clay outside the site did not exhibit constant volume 'undrained' behaviour during the period of the excavation.

3.9 Movements measured after 1987

Monitoring continued at the site until about 1993. During this period displacements were relatively small and the progressive loss of instruments makes it difficult to gain significant insights from the results. The full set of results is included in online supplementary data W3 and W4.

4. Conclusion

The main purpose of this paper has been to make available the database of monitoring results from the British Library excavation. The full data set is available online and the authors hope that this will be sufficient to allow further study and back-analysis.

The project progressed fairly slowly, and it has been shown that volumetric changes were apparent in the London Clay during the

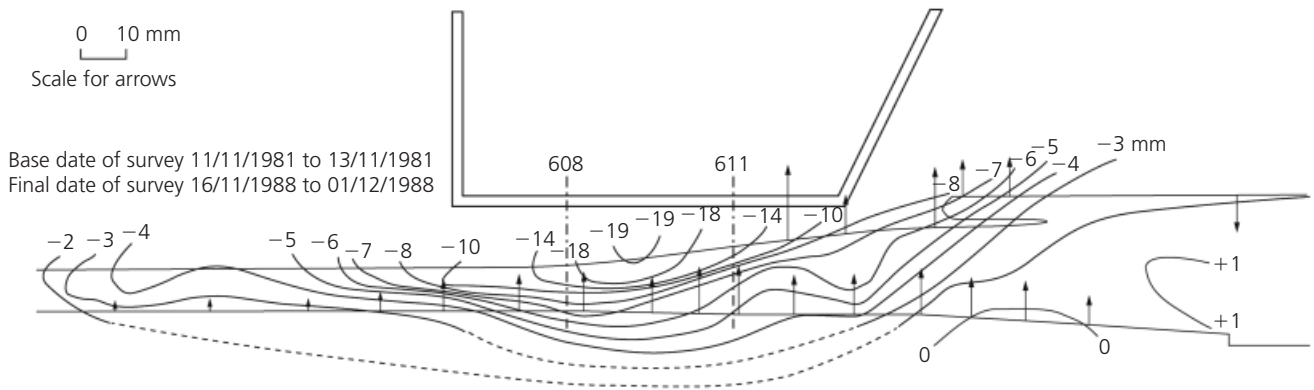

Figure 23. Contours of settlement for the Metropolitan Line tunnel between November 1981 and November 1988

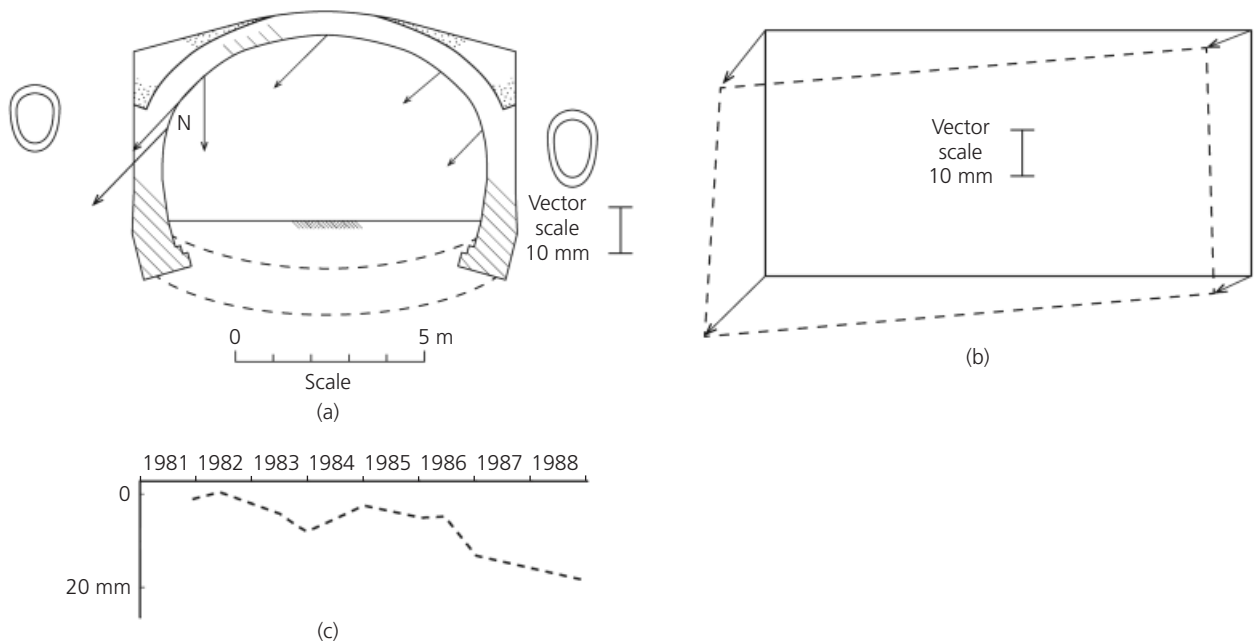

Figure 24. Displacements at (a) section 608 and (b) section 611 on the Metropolitan Line (located on Figure 23); (c) settlement record at point N

works. Some of these may have been related to saturated swelling, requiring ingress of water, but it seems likely that others, taking place rapidly during excavation, involved desaturation, or ‘undrained expansion’.

During excavation, retaining walls moved inwards and it is most likely that there were significant displacements of their toes, making it more difficult to derive absolute movements. By correlating with surface surveys of the tops of the inclinometer tubes, the toe movement and hence overall movement of the walls

have been assessed. Some early displacement of the walls was probably not recorded but the best indication of maximum total movement is probably about 32 mm.

The Victoria Line tunnels heaved by up to 22 mm, then settled back as weight was replaced on top of them. The largest settlement of an adjacent building was probably caused by inadequately sealed boreholes forming drains, rather than by the excavation itself. No damage to adjacent structures or tunnels was recorded.

Acknowledgements

The authors gratefully acknowledge the work of many former colleagues of the first author in Arup, in particular Peter Ryalls, Peter Evans, Tony Stevens and David Croft. Also thanks are owed to Jon Shillibeer for helping prepare some of the figures for the manuscript. The permission of the British Library to publish this paper is gratefully acknowledged.

Appendix: online supplementary data files

The following supplementary data files are available for download from the journal website

- W1_x-y coordinates.xlsx
- W2_Level&Traverse data.xlsx
- W3_Inclinometer data.xlsx
- W4_Extensometer data.xlsx
- W5_Site Progress Figures.pdf.

REFERENCES

- Burland JB and Hancock RJR (1977) Underground car park at the House of Commons, London: geotechnical aspects. *The Structural Engineer* **55(2)**: 87–100.
- Ground Engineering (1984) Deep foundations for the British Library. *Ground Engineering* **17(3)**: 20–26.
- Lord JA, Twine D and Yeow H (1994) *Foundations in Chalk: Funders Report/CP/13*. Construction Industry Research and Information Association, London, UK, Ciria Project Report 11.
- Loxham R, Simpson B and Gatenby NE (1990) Ground instrumentation at the British Library, Euston. *Geotechnical Instrumentation in Practice*. Thomas Telford, London, UK, pp. 257–273.
- Raison CA (1987a) Ground anchorages: component testing at the British Library, Euston. *Proceedings of the Institution of Civil Engineers – Part 1* **82(June)**: 615–626.
- Raison CA (1987b) Ground anchorages: drillhole alignment determination at the British Library, Euston. *Proceedings of the Institution of Civil Engineers – Part 1* **82(June)**: 627–634.
- Raison CA (1988) Discussion on Paper 9138 by Burland, J. B. and Kalra, J. C. *Proceedings of the Institution of Civil Engineers – Part 1* **84(Feb)**: 114–117.
- Ryalls PJ and Stevens A (1990) A large excavation at the New British Library in Central London. *Structural Survey* **8(1)**: 9–27.
- Simpson B (1992) Retaining structures: displacement and design. *Géotechnique* **42(4)**: 541–576.
- Simpson B, Calabresi G, Sommer H and Wallays M (1981) Design parameters for stiff clays. In *Proceedings of the 7th European Conference on Soil Mechanics and Foundation Engineering, Brighton, Design Parameters in Geotechnical Engineering*. British Geotechnical Society, London, UK, vol. 5, pp. 91–125.
- Simpson B, Blower T, Craig RN and Wilkinson WB (1989) *The Engineering Implications of Rising Groundwater in the Deep Aquifer Beneath London*. Construction Industry Research and Information Association, London, UK, Ciria Report SP69.
- St John Wilson C (1998) *The Design and Construction of The British Library. [Architects: Colin St John Wilson and Partners]*. The British Library, London, UK.
- Stevens A and Ryalls PJ (1990) Design and construction of the structured works, phase 1A, British Library, St Pancras. *The Structural Engineer* **68(9)**: 159–166.
- Vardanega PJ, Kolody E, Pennington SH, Morrison PRJ and Simpson B (2012a) Bored pile design in stiff clay I: codes of practice. *Proceedings of the Institution of Civil Engineers – Geotechnical Engineering* **165(4)**: 213–232.
- Vardanega PJ, Williamson M and Bolton MD (2012b) Bored pile design in stiff clay II: mechanisms and uncertainty. *Proceedings of the Institution of Civil Engineers – Geotechnical Engineering* **165(4)**: 233–246.

WHAT DO YOU THINK?

To discuss this paper, please email up to 500 words to the editor at journals@ice.org.uk. Your contribution will be forwarded to the author(s) for a reply and, if considered appropriate by the editorial panel, will be published as a discussion in a future issue of the journal.

Proceedings journals rely entirely on contributions sent in by civil engineering professionals, academics and students. Papers should be 2000–5000 words long (briefing papers should be 1000–2000 words long), with adequate illustrations and references. You can submit your paper online via www.icevirtuallibrary.com/content/journals, where you will also find detailed author guidelines.