



Doufexi, A., Armour, S. M. D., Butler, M. R. G., Nix, A. R., Bull, D. R., McGeehan, J. P., & Karlsson, P. (2002). A comparison of the HIPERLAN/2 and IEEE 802.11a wireless LAN standards. *IEEE Communications Magazine*, 40(5), 172 - 180. 10.1109/35.1000232

Link to published version (if available):
[10.1109/35.1000232](https://doi.org/10.1109/35.1000232)

[Link to publication record in Explore Bristol Research](#)
PDF-document

University of Bristol - Explore Bristol Research

General rights

This document is made available in accordance with publisher policies. Please cite only the published version using the reference above. Full terms of use are available:
<http://www.bristol.ac.uk/pure/about/ebr-terms.html>

Take down policy

Explore Bristol Research is a digital archive and the intention is that deposited content should not be removed. However, if you believe that this version of the work breaches copyright law please contact open-access@bristol.ac.uk and include the following information in your message:

- Your contact details
- Bibliographic details for the item, including a URL
- An outline of the nature of the complaint

On receipt of your message the Open Access Team will immediately investigate your claim, make an initial judgement of the validity of the claim and, where appropriate, withdraw the item in question from public view.

A Comparison of the HIPERLAN/2 and IEEE 802.11a Wireless LAN Standards

*Angela Doufexi, Simon Armour, Michael Butler, Andrew Nix, David Bull, and Joseph McGeehan
Centre for Communications Research, University of Bristol, UK
Peter Karlsson, Radio System Malmo, Telia Research AB, Sweden*

ABSTRACT

At present, WLANs supporting broadband multimedia communication are being developed and standardized around the world. Standards include HIPERLAN/2, defined by ETSI BRAN, 802.11a, defined by the IEEE, and HiSWANa defined by MMAC. These systems provide channel adaptive data rates up to 54 Mb/s (in a 20 MHz channel spacing) in the 5 GHz radio band. In this article an overview of the HIPERLAN/2 and 802.11a standards is presented together with software simulated physical layer performance results for each of the defined transmission modes. Furthermore, the differences between these two standards are highlighted (packet size, upper protocol layers etc.), and the effects of these differences on throughput are analyzed and discussed.

INTRODUCTION

Wireless LANs (WLANs) provide wideband wireless connectivity between PCs and other consumer electronic devices as well as access to the core network and other equipment in corporate, public, and home environments. WLANs also offer an easy way to configure computer networks by avoiding the need for cable installation. Another potential application of WLANs is as a high-speed extension to cellular radio access networks.

Currently, WLAN technology operating in the 2.4 GHz industrial, scientific, and medical (ISM) band is widely used. Besides proprietary technology, IEEE 802.11 provides an internationally accepted standard for WLANs with data rates up to 2 Mb/s. A higher-rate extension to this standard, 802.11b, will achieve data rates of up to 11 Mb/s, also operating in the 2.4 GHz ISM band [1]. However, the ever increasing demand for higher bit rates and the need for dedicated spectrum have led to the development of new standards and the allocation of new spectrum. In North America, the FCC has allocated

300 MHz of spectrum to the unlicensed national information infrastructure (U-NII) band (at 5 GHz), and the IEEE has developed another extension to the 802.11 physical (PHY) layer known as 802.11a [2]. In Europe, the ERC have designated a total of 455 MHz of spectrum (also at 5 GHz) for WLANs, and the European Telecommunications Standards Institute (ETSI) has developed the HIPERLAN/2 standard [3]. In Japan, spectrum has also been allocated at 5 GHz, and the HiSWANa standard has been developed by ARIB.

The PHY layers of these new standards will support multiple transmission modes, providing raw data rates of up to 54 Mb/s where channel conditions permit. However, the actual throughput achieved is also highly dependent on the medium access control (MAC).

Close cooperation between ETSI BRAN, ARIB MMAC, and IEEE 802.11 has ensured that the PHY layers of the various 5 GHz WLAN standards are broadly harmonized. The large-scale worldwide markets and harmonization of the PHY layers should facilitate low-cost production of devices conforming to all three standards. As a result, all standards have received considerable industrial backing (e.g., the HIPERLAN/2 Global Forum) and look set to dominate the future of WLAN technology in the 5 GHz band.

This article focuses on the HIPERLAN/2 and 802.11a standards, and identifies their similarities and differences. The two standards differ primarily in the MAC [1, 4–6]. However, some differences also occur in the PHY layers.

The HIPERLAN/2 radio network is defined in such a way that there are core-independent PHY and data link control (DLC) layers as well as a set of convergence layers (CLs) for interworking. The CLs include Ethernet, asynchronous transfer mode (ATM), and IEEE 1394 infrastructure [7], and technical specifications for HIPERLAN/2–third generation (3G) interworking are expected to be completed mid-2002. IEEE 802.11a defines simi-

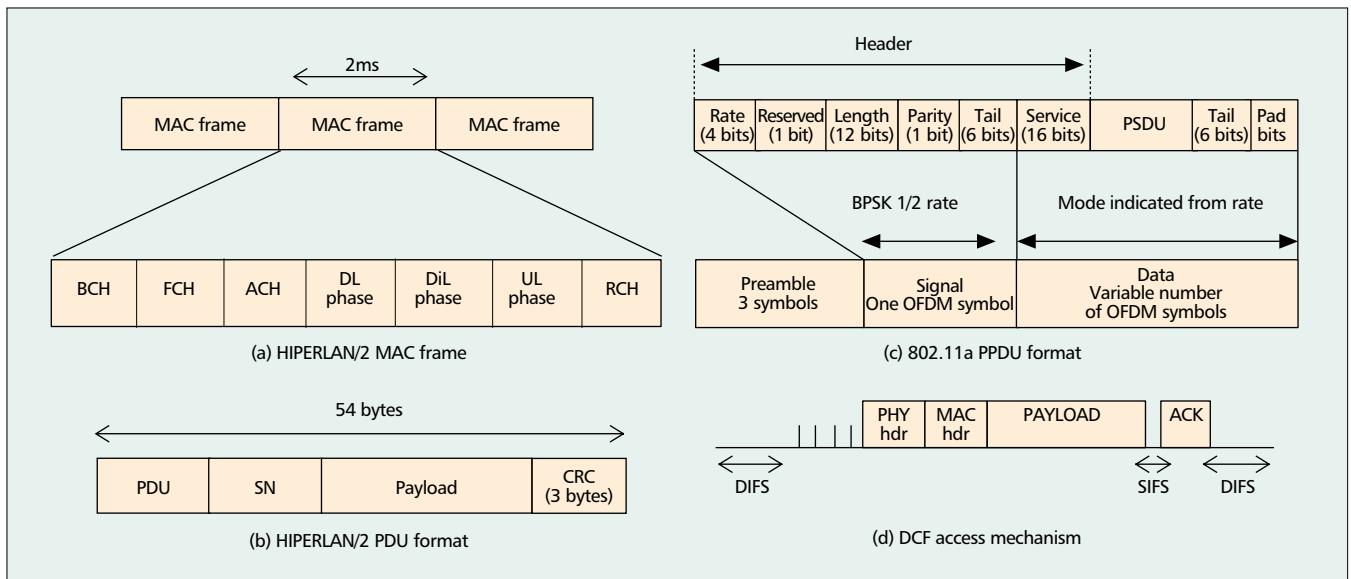

■ **Figure 1.** MAC structures for HIPERLAN/2 and 802.11a.

larly independent PHY and MAC layers (with the MAC common to multiple PHYs within the 802.11 standard). A similar approach to network protocol convergence is expected.

This article is organized as follows. In the first section the MACs specified by the two standards are presented. Then their PHY layers are described and compared. The channel models that have been specified for evaluation of both standards are presented. The results of PHY layer software simulations for the two standards are given in the form of packet error rate (PER) performance vs. carrier-to-noise ratio (C/N) for the different channel types and transmission modes. These results facilitate an examination and comparison of the performance of the two standards. We consider the link adaptation mechanism and present an analysis of the throughput performance of the two standards. We discuss the results and conclude the article.

MEDIUM ACCESS CONTROL

The main differences between the IEEE 802.11a (at 5 GHz) and HIPERLAN/2 standards occur at the MAC layer [1, 5–7].

In HIPERLAN/2, medium access is based on a TDMA/TDD approach using a MAC frame with a period of 2 ms [8]. This frame comprises uplink (to the AP), downlink (from the AP), and direct link (DiL, directly between two stations) phases. These phases are scheduled centrally by the AP, which informs mobile terminals (MTs), at which point in time in the MAC frame they are allowed to transmit their data. Time slots are allocated dynamically depending on the need for transmission resources. The HIPERLAN/2 MAC is designed to provide quality of service support, essential to many multimedia and real-time applications.

IEEE 802.11a uses a distributed MAC protocol that obviates the requirement for any centralized control. The MAC is based on a carrier sense multiple access with collision avoidance (CSMA/CA) protocol [1, 2]. This protocol is often described as “listen before talk” because

an MT must sense the radio channel before transmitting. If the channel is free, transmission begins; otherwise, an exponential backoff period is implemented before the channel is sensed once more. The use of a distributed MAC makes IEEE 802.11a more suitable for ad hoc networking and non-real-time applications.

Another significant difference between the two standards is the length of the packets employed: HIPERLAN/2 employs fixed length packets; 802.11a supports variable length packets.

The HIPERLAN/2 and 802.11a MAC layers are discussed in more detail in the next two sections.

HIPERLAN/2 MAC [8]

The MAC frame structure (Fig. 1a) comprises time slots for broadcast control (BCH), frame control (FCH), access feedback control (ACH), and data transmission in downlink (DL), uplink (UL), and direct link (DiL) phases, which are allocated dynamically depending on the need for transmission resources. An MT first has to request capacity from the AP in order to send data. This is performed in the random access channel (RCH), where contention for the same time slot is allowed.

DL, UL, and DiL phases consist of two types of PDUs: long and short. The long PDUs (illustrated in Fig. 1b) have a size of 54 bytes and contain control or user data. The payload comprises 48 bytes, and the remaining bytes are used for the PDU type, a sequence number (SN), and cyclic redundancy check (CRC-24). Long PDUs are referred to as the long transport channel (LCH).

Short PDUs contain only control data and have a size of 9 bytes. They may contain resource requests, automatic repeat request (ARQ) messages, and so on, and are referred to as the short transport channel (SCH).

Traffic from multiple connections to/from one MT can be multiplexed onto one PDU train, which contains long and short PDUs. A physical burst is composed of the PDU train payload preceded by a preamble, and is the unit to be transmitted via the PHY layer [3].

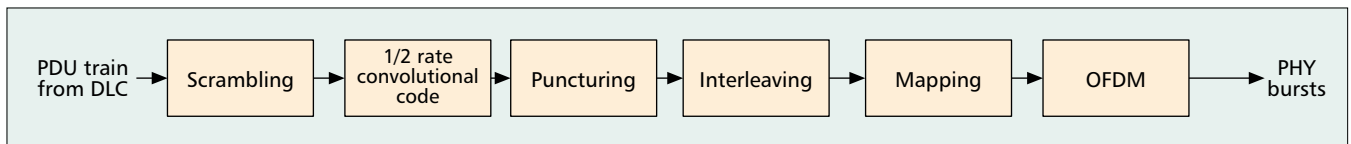

■ **Figure 2.** HIPERLAN/2 & IEEE 802.11a transmitter PHY layer.

IEEE 802.11 MAC

To access the medium, IEEE 802.11 provides two types of service: asynchronous and contention-free. The asynchronous type implements a CSMA/CA MAC protocol, with binary exponential backoff, known as the distributed coordination function (DCF). DCF defines a basic access method and an optional four-way handshaking technique, known as the *request-to-send/clear-to-send* (RTS/CTS) method [9]. The contention-free service is provided by the point coordination function (PCF) in order to support time-bounded services. PCF is optional and will not be considered in this article.

According to the DCF, an MT must sense the medium for a specific time interval; if the medium is idle, it can start transmitting the packet [6, 9]. Otherwise, the transmission is deferred and a backoff process begins, which means that the MT has to wait for a time interval. Once the backoff time has expired, the MT can access the medium again. Because a collision in a wireless environment is undetectable, a positive acknowledgment is used to notify that a frame has been successfully received. If this acknowledgment is not received, the terminal will retransmit the packet.

In this article the basic DCF access mechanism is considered. The transmission cycle consists of the following phases (Fig. 1d): distributed interframe space (DIFS), backoff, data packet transmission, short interframe space (SIFS), and acknowledgment (ACK).

A PHY layer convergence procedure (PLCP) maps a MAC PDU into a frame format. Figure 1c shows the format of a complete packet (PPDU) in 802.11a, including the preamble, header, and PHY layer service data unit (PSDU or payload):

- The header contains information about the length of the payload and the transmission rate, a parity bit, and six zero tail bits. The header is always transmitted using the lowest-rate transmission mode in order to ensure robust reception. Hence, it is mapped onto a single binary phase shift keying (BPSK) modulated orthogonal frequency-division multiplexed (OFDM) symbol.
- The rate field conveys information about the type of modulation and the coding rate used in the rest of the packet.
- The length field takes a value between 1 and 4095, and specifies the number of bytes in the PSDU.
- The parity bit is a positive parity for the first 17 bits of the header.
- The 6 tail bits are used to reset the convolutional encoder and terminate the code trellis in the decoder.
- The first 7 bits of the service field are set to zero and used to initialize the descrambler. The remaining 9 bits are reserved for future use.
- The pad bits are used to ensure that the number of bits in the PPDU maps to an integer number of OFDM symbols.

THE PHYSICAL LAYER OF HIPERLAN/2 AND IEEE 802.11A

The PHY layers of both standards are very similar and are based on the use of OFDM. OFDM is used to combat frequency selective fading and to randomize the burst errors caused by a wideband fading channel. The PHY layer modes (Table 1) with different coding and modulation schemes are selected by a link adaptation scheme [7, 10]. The exact mechanism of this process is not specified in the standards. Figure 2 shows the reference configuration of the transmitter.

Mode	Modulation	Coding rate R	Nominal bit rate (Mb/s)	Coded bits per subcarrier	Coded bits per OFDM symbol	Data bits per OFDM symbol
1	BPSK	1/2	6	1	48	24
2	BPSK	3/4	9	1	48	36
3	QPSK	1/2	12	2	96	48
4	QPSK	3/4	18	2	96	72
5	16-QAM (H/2 only)	9/16	27	4	192	108
5	16-QAM (IEEE only)	1/2	24	4	192	96
6	16QAM	3/4	36	4	192	144
7	64QAM	3/4	54	6	288	216
8	64-QAM (IEEE only)	2/3	48	6	288	192

■ **Table 1.** Mode-dependent parameters.

Data for transmission is supplied to the PHY layer in the form of an input PDU train or PPDU frame, as explained earlier. This is then input to a scrambler that prevents long runs of 1s and 0s in the input data being input to the remainder of the modulation process. Although both 802.11a and HIPERLAN/2 scramble the data with a length 127 pseudo-random sequence, the initialization of the scrambler is different.

The scrambled data is input to a convolutional encoder. The encoder consists of a 1/2 rate mother code and subsequent puncturing. The puncturing schemes facilitate the use of code rates 1/2, 3/4, 9/16 (HIPERLAN/2 only), and 2/3 (802.11a only). In the case of 16-quadrature amplitude modulation (QAM), HIPERLAN/2 uses rate 9/16 instead of rate 1/2 in order to ensure an integer number of OFDM symbols per PDU train. The rate 2/3 is used only for the case of 64-QAM in 802.11a. Note that there is no equivalent mode for HIPERLAN/2. HIPERLAN/2 also uses additional puncturing in order to keep an integer number of OFDM symbols with 54-byte PDUs.

The coded data is interleaved in order to prevent error bursts from being input to the convolutional decoding process in the receiver.

The interleaved data is subsequently mapped to data symbols according to either a BPSK, quadrature PSK (QPSK), 16-QAM, or 64-QAM constellation. OFDM modulation is implemented by means of an inverse fast Fourier transform (FFT). 48 data symbols and 4 pilots are transmitted in parallel in the form of one OFDM symbol.

Numerical values for the OFDM parameters are given in Table 2. In order to prevent intersymbol interference (ISI) and intercarrier interference (ICI) due to delay spread, a guard interval is implemented by means of a cyclic extension. Thus, each OFDM symbol is preceded by a periodic extension of the symbol itself. The total OFDM symbol duration is $T_{total} = T_g + T$, where T_g represents the guard interval and T the useful OFDM symbol duration. When the guard interval is longer than the excess delay of the radio channel, ISI is eliminated.

The OFDM receiver basically performs the reverse operations of the transmitter. However, the receiver is also required to undertake AGC, time and frequency synchronization, and channel estimation. Training sequences are provided in the preamble for the specific purpose of supporting these functions. Two OFDM symbols are provided in the preamble in order to support the channel estimation process. A prior knowledge of the transmitted preamble signal facilitates the generation of a vector defining the channel estimate, commonly referred to as the channel state information (CSI).

The channel estimation preamble is formed such that the two symbols effectively provide a single guard interval of length 1.6 μ s. This format makes it particularly robust to ISI. By averaging over two OFDM symbols, the distorting effects of noise on the channel estimation process can also be reduced.

HIPERLAN/2 and 802.11a use different training sequences in the preamble. The training

Parameter	Value
Sampling rate (f_s)	20 MHz
Useful symbol duration (T_U)	3.2 μ s
Guard interval duration (T_g)	0.8 μ s
Total symbol duration (T_{Total})	4.0 μ s
Number of data subcarriers (N_D)	48
Number of pilot subcarriers (N_P)	4
FFT size	64
Subcarrier spacing (Δ_f)	0.3125 MHz
Total bandwidth (B)	16.875 MHz

■ Table 2. OFDM parameters.

Name	RMS delay spread	Characteristic	Environment
A	50 ns	Rayleigh	Office NLOS
B	100 ns	Rayleigh	NLOS
C	150 ns	Rayleigh	NLOS
D	140 ns	Rice	LOS
E	250 ns	Rayleigh	NLOS

■ Table 3. Channel models.

symbols used for channel estimation are the same, but the sequences provided for time and frequency synchronization are different.

Decoding of the convolutional code is typically implemented by means of a Viterbi decoder.

CHANNEL MODELS

HIPERLAN/2 and IEEE 802.11a systems will be deployed in a wide range of environments such as offices, industrial buildings, exhibition halls, and residential environments. Different channel models have been produced to represent these different environments [11]. Table 3 summarizes the channel models that were specified for the two standards and also used to perform the simulations presented in this article. The channels are wideband, with Rayleigh or Rician modeled tapped delay lines. Each tap suffers independent Rayleigh or Rician (in the case of channel model D) fading with a mean corresponding to an exponentially decaying average power delay profile. For the results presented in this article, 2000 quasi-static independently random instances of the given channel model were considered.

PHYSICAL LAYER SIMULATION RESULTS

A software simulation tool (based on the PHY layer specification of the two standards and employing the channel models described above) has been developed by the authors and used to analyze the

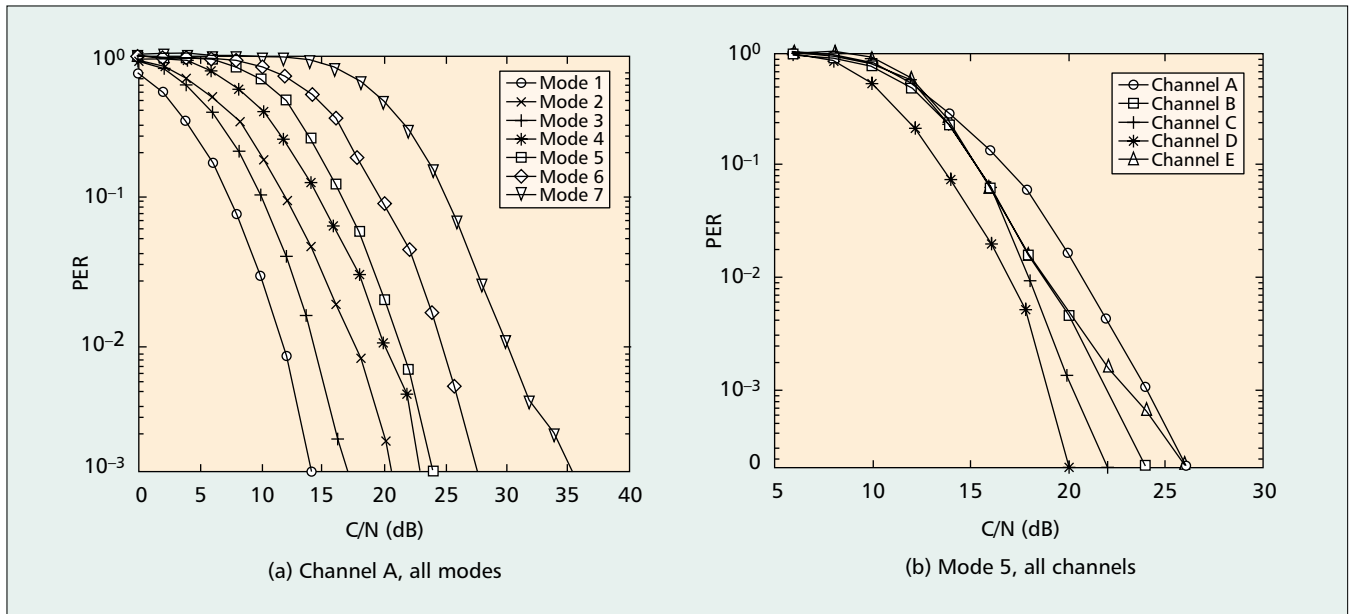

■ **Figure 3.** PER performance of HIPERLAN/2.

performance of the different transmission modes. The PHY layer simulation results take the form of packet (PDU or PSDU) error rate (PER) vs. average C/N. In all the simulations, soft decision Viterbi decoding (with the metric weighted according to the CSI) was used.

HIPERLAN/2 PERFORMANCE RESULTS

Figure 3a presents the performance results for the different modes of HIPERLAN/2 vs. average C/N for channel model A. Channel model A is typical of large office environments with non-line-of-sight (NLOS) propagation. Note that similar results have been observed elsewhere [12].

It can be seen that the C/N requirement increases for modes 1, 3, 2, 4, 5, 6, and 7 respectively. The degradation in performance in mode 2 (BPSK 3/4) is due to the fact that the punctured convolutional code does not cope well with the lack of frequency diversity in channel A. Errors due to large and deep fades in the frequency domain are difficult to correct using this code. Since mode 2 is inferior to mode 3 in terms of both C/N requirement and data rate, it is superfluous for operation in channel A or similar conditions.

A reasonable point of operation for packet services without delay constraint may lie in a PER of 1–10 percent [7, 10]. The respective C/N requirement is therefore between 7–30 dB depending on the mode.

Figure 3b shows PER performance vs. mean C/N for mode 5 for all the specified channels. It can be seen that as the delay spread increases, the performance is improved in the Rayleigh channels until the delay spread becomes so large that ISI and ICI become limiting factors (as is the case for channel E). Channels B, C, and D have increasingly better performances than channel A due to the increased frequency diversity of the channels. As expected, channel D has slightly better performance than channel C because it is modeled as a Rician channel. In channel E the excess

channel delay of 1760 ns is much larger than the 800 ns guard interval. As a result, ISI cannot be completely eliminated.

IEEE 802.11A PERFORMANCE RESULTS

Figure 4a presents the performances of all modes of IEEE 802.11a against average C/N for channel model A. Note that for these results, the PSDU size for all modes is 512 bytes. As would be expected, the relative performance of these modes for 802.11a follows a similar trend as for HIPERLAN/2.

It has been observed that the bit error rate (BER) performances of the two standards are the same [13]. This is expected due to the similarity of the PHY layers and the common mode parameters. However, the PER performances of the two standards are different. This is due to the different packet sizes used in the simulations (here we have considered 54 bytes for HIPERLAN/2 and 512 bytes for 802.11a).

The 802.11a results also include mode 8, which has no equivalent in HIPERLAN/2. The PER performance of this mode lies between modes 6 and 7. At higher C/N the performance of mode 8 is similar to that of mode 6. However, mode 8 offers an additional 12 Mb/s data rate. This is due to the lower-rate code offsetting the additional C/N requirement of the larger constellation size. Thus, for values of C/N where HIPERLAN/2 would use mode 6, 802.11a will exhibit a significant performance advantage.

Figure 4b presents the PER performance of mode 6 for different PSDU lengths. As can be seen, a larger PSDU size results in an increased C/N requirement to maintain the same PER. This is also expected since a longer PSDU is more likely to be in error for a given BER. Note that the BER does not vary as a function of PSDU size. It can be seen that an increase in PSDU size from 54 to 512 bytes results in a significant change in PER performance (PER

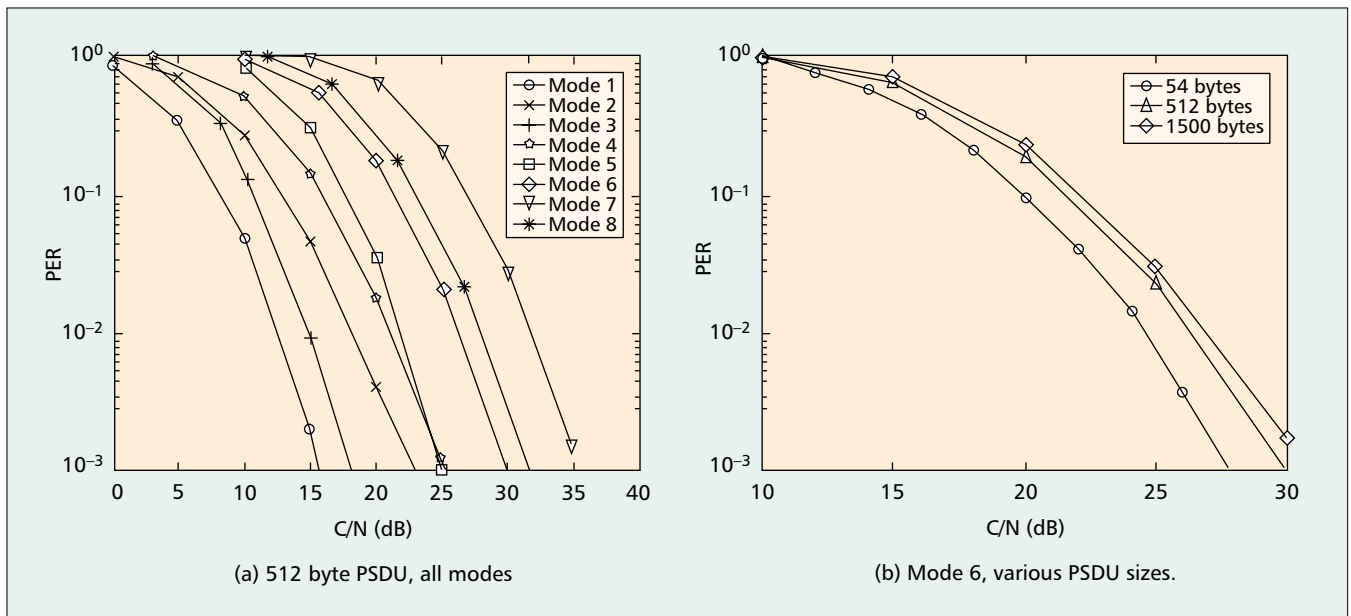

■ **Figure 4.** PER performance of 802.11a in channel A.

increases from 7×10^{-3} to 2×10^{-2} for a C/N value of 25 dB). Note that similar results have been observed elsewhere [12].

The increased C/N requirement (for a given PER) of the larger PSDU size means that either an increase in transmit power or a change of mode is required in order to maintain PER performance. This has interesting implications on transmission performance and system capacity of 802.11a. A larger PSDU has a smaller overhead requirement for the header, signal field, and so on, and hence is more efficient. However, if the use of a larger PSDU can only be achieved by using a lower transmission mode, efficiency is reduced since each PSDU occupies more transmission time. This is considered further in a later section.

LINK ADAPTATION

The PHY layer modes (Table 1) with different coding and modulation schemes are selected by a link adaptation scheme. Link adaptation schemes may use a variety of link quality measurements like PER, received signal strength, and so on [7, 10].

Each packet (PDU or PPDU) uses CRC- r (Cyclic Redundancy Check) block codes for error detection, where $r = 32$ for IEEE 802.11a and 24 or 16 for HIPERLAN/2. If a packet is detected to be erroneous by the CRC codes (or a positive acknowledgment is not received in 802.11a), the terminal will retransmit the packet. In HIPERLAN/2 a selective repeat ARQ scheme has been chosen for error control. A stop and wait ARQ scheme is specified for 802.11.

A simple approximation of the link throughput when retransmission is employed is given by: Throughput = $R(1 - PER)$, where R and PER are the bit rate and PER for a specific mode, respectively. In case of ideal link adaptation (in terms of the data rate achieved), the mode with the highest throughput would be chosen for each

instantaneous C/N value [7, 10]. Note that perfect link adaptation is assumed in the remainder of this article.

THROUGHPUT PERFORMANCE

The throughput performance of the two WLAN standards is a function of both PHY and MAC layer performance. The two distinct MAC protocols employed impose different overhead requirements on the two standards, with a corresponding impact on throughput. Overheads in the MAC layer result from many factors, such as gap time, preamble, header fields, and ACK frames. The measurement of net throughput in WLANs is commonly achieved by measuring the time it takes to transfer large files between a server PC and wireless clients [14]. In this article an analytical model is employed.

Figure 5a presents the *maximum* throughput achieved by the different modes of HIPERLAN/2 for various numbers of MTs. This is determined from the fractions of the MAC frame occupied by payload data and overhead, respectively [4]. It is assumed that there is one connection per MT. It can be seen that the throughput performance depends on the number of data bursts in the uplink, downlink, and direct link phases. As the number of data bursts (or number of MTs) increases, the MAC frame becomes “fragmented” and throughput decreases. This is primarily due to two factors. First, as the number of data bursts increases, the quantity of information required in the FCH also increases. This is due to the fact that the FCH is used to communicate information on the scheduling of these data bursts between the access point (AP) and MTs. Second, each burst is preceded by a preamble sequence. Thus, as the UL, DL, and DiL phases become fragmented, the proportion of each MAC frame occupied by the FCH and preambles increases, and the proportion occupied by PDU trains decreases.

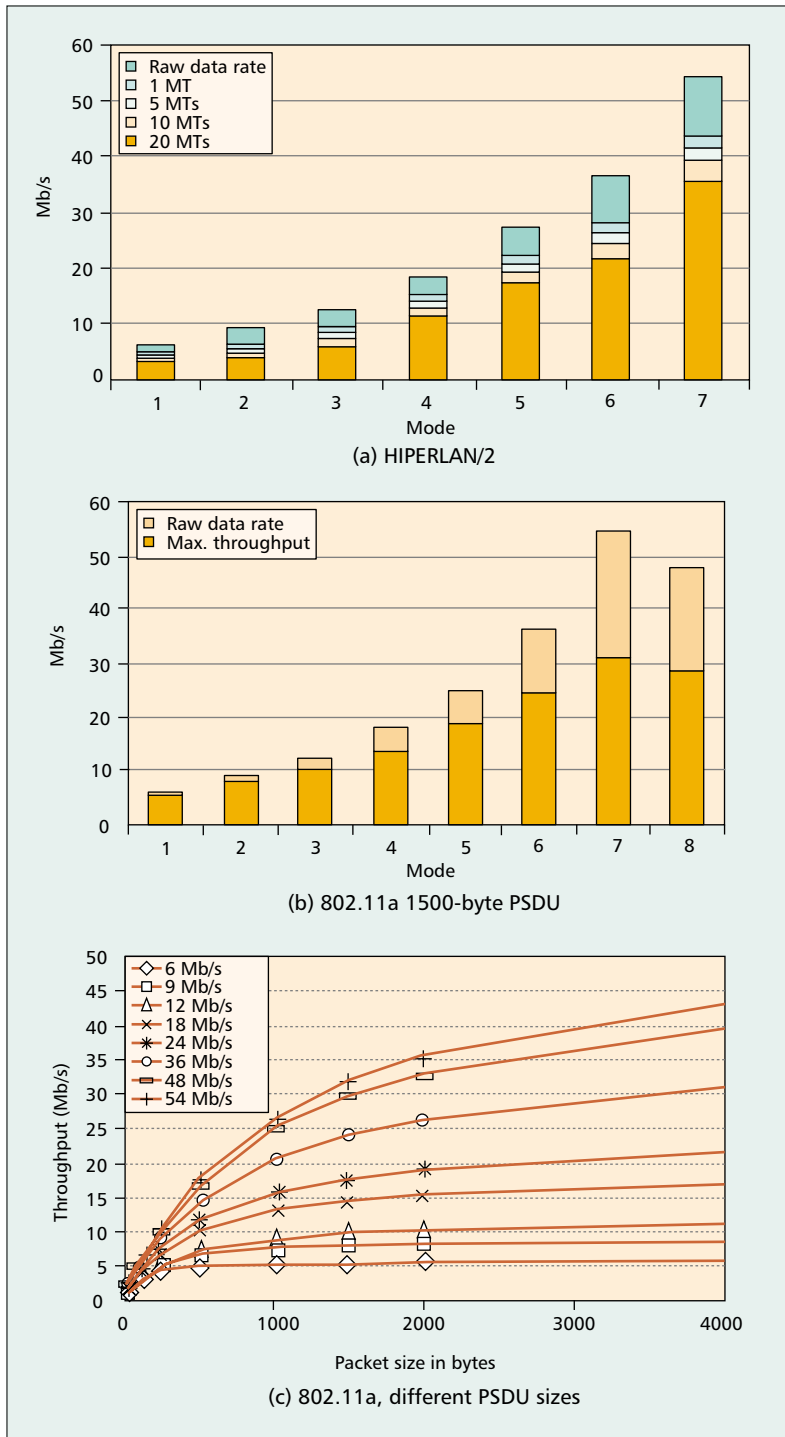

Figure 5. Maximum throughput.

Clearly, the throughput performance of HIPERLAN/2 depends on how effectively the central scheduler manages the allocation of resources and thereby minimizes fragmentation of the MAC frame.

Figure 5b presents the *maximum* throughput achieved by the different modes of 802.11a for a PSDU size of 1500 bytes. It is assumed that only one terminal transmits and one terminal receives (no collisions) and that the medium is never idle [4]. The total throughput is given by: throughput = payload/transmission cycle [4–6]. As can be seen from Fig. 5c, the throughput depends largely on PSDU size.

Mode	IEEE 802.11a		HIPERLAN/2	
	Mb/s	%	Mb/s	%
6	5.3	88	4.6	77
24/27	18	74	21.12	78
36	24	67	27.84	77
54	32	59	42.24	78

Table 4. Throughput with 1500-byte-long packets.

From Fig. 5 it can be seen that HIPERLAN/2 and 802.11 have similar throughput performances only in the case where the PSDU size in 802.11a approaches its maximum (i.e., 4096 bytes). As PSDU size decreases, the performance of 802.11a deteriorates due to the overhead, which is worse for higher transmission modes. However, as can be seen from Fig. 4b, a larger PSDU size results in an increased C/N requirement to maintain the same PER. Thus, effective combination of packet size and transmission mode is essential if the worst performance of 802.11a is to be avoided.

Based on the PER analysis presented in Figs. 3 and 4, and the throughput analysis presented in Fig. 5, it is possible to analyze the performance in terms of throughput with link adaptation as a function of the received C/N using the equation given earlier.

If the 802.11 system is connected to an 802.3 wired connection (e.g., at the AP), the maximum payload of the packets becomes 1500 bytes [14]. Throughput results with link adaptation are shown in Fig. 6a for this case; Fig. 6b presents the throughput performance with link adaptation for HIPERLAN/2.

Table 4 shows a comparison of the throughput for 1500-byte-long packets (HIPERLAN/2 uses segmentation and reassembly, 802.11a without RTS/CTS). It can be seen that the relative throughput for 802.11a with 1500-byte packets varies from 59–88 percent depending on the PHY mode used. The reason for this is that the time required for SIFS and DIFS is independent of the mode, so it affects the higher data rates more (for the same duration of time higher rates transmit more data). This is not the case for HIPERLAN/2, where the relative throughput does not significantly depend on the mode. The throughput of 802.11a can be expected to decrease further in realistic traffic situations where a mean packet size of approximately 400 bytes can be expected.

Thus, it has been shown that HIPERLAN/2 achieves superior throughput to 802.11a for all values of C/N. However, 802.11a does see some benefit from the additional mode 8.

CONCLUSIONS

Performance results in terms of PER have been presented for both HIPERLAN/2 and IEEE 802.11a standards, and for all transmission modes for the case of transmission over channel A. As expected, the BER performances of the two standards are the same. Where PSDU size

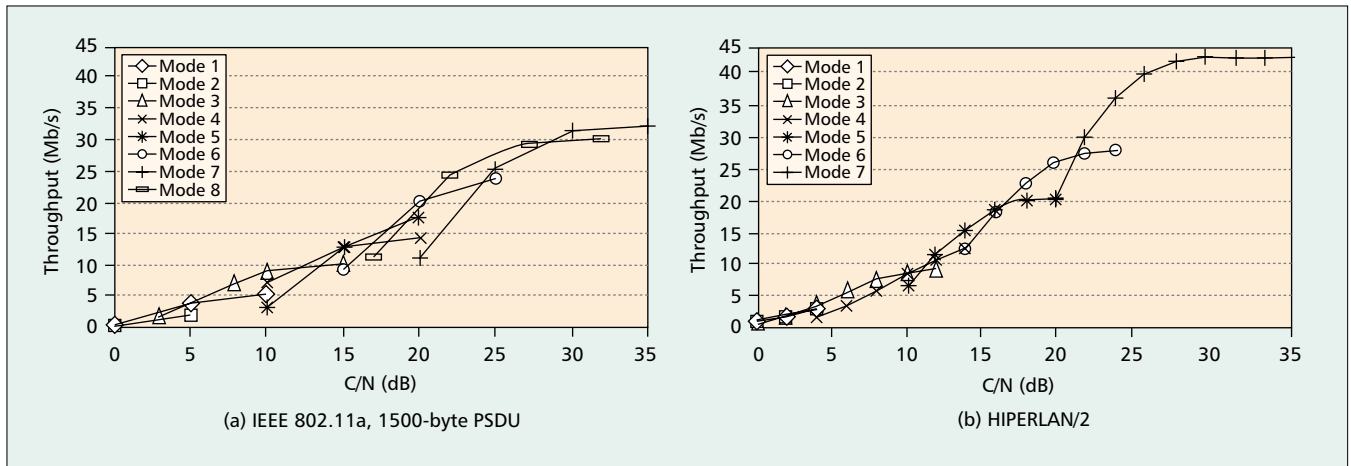

■ Figure 6. Throughput with link adaptation (channel A).

in 802.11a differs from PDU size in HIPERLAN/2, the PER performances of the two standards differ. In 802.11a, which has variable size PSDUs, results suggest that the PSDU size will have a significant impact on performance. Larger PSDUs will improve the link throughput but will result in increased PER or else require the use of lower-rate transmission modes. Even so, the highest throughput is achieved by larger PSDUs. Thus, when connected to an 802.3 wired connection, a 1500-byte PSDU gives the highest possible throughput.

Because HIPERLAN/2 has a fixed length PDU, throughput is independent of packet size. However, efficient scheduling is required for HIPERLAN/2 to prevent unnecessary fragmentation of the MAC frame and thereby maintain maximal throughput.

It has been shown that HIPERLAN/2 achieves superior throughput to IEEE 802.11a. This is due to the use of centrally controlled medium access. This MAC protocol is also more suitable for time-bounded applications. However, the distributed MAC employed by IEEE 802.11a offers advantages for ad hoc wireless computing. The "listen before talk" nature of the protocol employed is also expected to offer advantages in the presence of interference [15] (HIPERLAN/2 will employ dynamic frequency selection and transmit power control to combat interference). The additional mode supported by 802.11a also serves to achieve a small increase in throughput.

Performance results have also been presented for both standards for transmission in mode 5 over channels A, B, C, D, and E. These results indicate that system performance improves as the RMS delay spread increases, until the excess delay significantly exceeds the guard interval length. This characteristic is due to the use of OFDM instead of a single-carrier system. OFDM exploits the increased frequency diversity that results from high RMS delay spread. However, when the excess delay exceeds the guard interval length, ISI impairs performance.

REFERENCES

[1] R. Van Nee *et al.*, "New High-Rate Wireless LAN Standards", *IEEE Commun. Mag.*, vol. 37, no.12, Dec. 1999, pp. 82-88.

[2] IEEE Std 802.11a/D7.0-1999, "Part11: Wireless LAN Medium Access Control (MAC) and Physical Layer (PHY) Specifications: High Speed Physical Layer in the GHz Band."

[3] ETSI, "Broadband Radio Access Networks (BRAN); HIPERLAN type 2 technical specification; Physical (PHY) layer," Aug. 1999.

[4] A. Doufexi *et al.*, "Throughput Performance of WLANs Operating at 5GHz Based on Link Simulations with Real and Statistical Channels," *IEEE VTC '01 Spring*.

[5] G. Anastasi, L. Lenzi, and E. Mingozzi "MAC Protocols for Wideband Wireless Local Access: Evolution Toward Wireless ATM", *IEEE Pers. Commun.*, Oct. 1998, pp. 53-64.

[6] A. Hettich and M. Schrother, "IEEE 802.11a or ETSI BRAN HIPERLAN/2: Who Will Win the Race for a High-Speed Wireless LAN Standard," *Euro. WL Conf.*, Germany, Oct. 1999, pp. 169-74.

[7] J. Khun-Jush *et al.*, "Structure and Performance of HIPERLAN/2 Physical Layer," *IEEE VTC '99 Fall*, pp. 2667-71.

[8] ETSI, "Broadband Radio Access Networks (BRAN); HIPERLAN Type 2; Data Link Control (DLC) Layer; Part 1: Basic Transport Functions," Dec.1999.

[9] G. Bianchi, "IEEE802.11-Saturation Throughput Analysis", *IEEE Commun. Lett.*, no. 12, Dec. 1998.

[10] A. Doufexi *et al.*, "A Study of the Performance of HIPERLAN/2 and IEEE 802.11a Physical Layers," *IEEE VTC '01 Spring*.

[11] J. Medbo and P. Schramm "Channel Models for HIPERLAN/2" ETSI/BRAN doc. no. 3ER1085B, 1998.

[12] H. Li, G. Malmgren, and M. Pauli, "Performance Comparison of the Radio Link Protocols of IEEE802.11a and HIPERLAN/2," *IEEE VTC 2000*.

[13] A. Doufexi *et al.*, "A Comparison of HIPERLAN/2 and IEEE 802.11a Physical and MAC Layers," *IEEE Symp. Commun. Vehic. Tech.*, (SCVT-2000), p 13-19.

[14] A. Kamerman and G. Aben "Throughput Performance of WLANs Operating at 2.4 and 5 GHz," *PIMRC 2000*.

[15] S. Armour *et al.*, "The Impact of Power Limitations and Adjacent Residence Interference on the Performance of WLANs for Home Networking Applications," *IEEE Trans. Cons. Elect.*, Aug. 2001, vol. 47, no. 3.

BIOGRAPHIES

ANGELA DOUFEXI [M] (A.Doufexi@bristol.ac.uk) graduated from the University of Athens with a B.Sc. in physics in 1996. She received an M.Sc. with distinction in electronic engineering from Cardiff University, United Kingdom, in 1998. She recently completed her Ph.D. at the University of Bristol, United Kingdom, on the subject of OFDM-based multimedia WLANs. She is currently working as a research assistant at the University of Bristol and is contributing to the European Union SATURN project. Her research interests include OFDM systems, wireless LANs, smart antennas, and error-resilient video transmission. She has published more than 20 journal and conference papers in these areas. She is a member of the IEE.

SIMON ARMOUR [M] (Simon.Armour@bristol.ac.uk) received his B.Eng. degree from the University of Bath in 1996 and his Ph.D. degree from the University of Bristol in 2001. Fol-

Efficient scheduling is required for HIPERLAN/2 to prevent unnecessary fragmentation of the MAC frame and thereby maintain maximal throughput.

lowing a period of post-doctoral research in the area of advanced WLAN technologies, he was appointed to the position of lecturer in software radio at the University of Bristol in 2001. His research interests include software radio, WLANs/PANs, wireless home networks, and multicarrier modulation, and he has published over 30 papers on these subjects. He is a member of the IEE.

MICHAEL BUTLER (Mike.Butler@bristol.ac.uk) received his B.Eng. in computer systems engineering and M.Sc. in telecommunication systems and signal processing from the Universities of Warwick and Bristol, respectively. Currently, he is studying toward a Ph.D. within the Center for Communications Research at the University of Bristol. His research work has included PHY layer modeling, and development of enhanced modem architectures for HIPERLAN/2 and IEEE 802.11 WLAN systems.

ANDREW NIX [M] (Andy.Nix@bristol.ac.uk) received his B.Eng. and Ph.D. degrees from the University of Bristol in 1989 and 1993 respectively. He is currently professor of wireless communication systems. His main research interests include broadband wireless communications, radiowave propagation modeling, cellular network optimization and advanced digital modulation/reception techniques. He currently leads the propagation modeling and WLAN groups in the Center for Communications Research (CCR). He has published in excess of 160 journal and conference papers.

DAVID BULL (Dave.Bull@bristol.ac.uk) is currently professor of signal processing at the University of Bristol. He leads the signal processing group in CCR at Bristol and is head of the Department of Electrical and Electronic Engineering. He has worked widely in the area of 1D and 2D signal pro-

cessing, and has published well over 200 papers and a book in these areas. His recent research has focused on the problems of image and video communications, in particular error-resilient source coding, linear and nonlinear filter banks, scalable methods, content-based coding, and architectural optimization. He is currently a director of Provision Communications Technologies Ltd.

JOE MCGEEHAN (J.P.McGeehan@bristol.ac.uk) is presently professor of communications engineering and dean of engineering at the University of Bristol. He is also managing director of Toshiba Research Europe Limited: Telecommunications Research Laboratory (Bristol). He has been actively researching spectrum-efficient mobile radio communication systems since 1973, and has pioneered work in many areas, including linear modulation, linearized power amplifiers, smart antennas, propagation modeling/prediction using raytracing, and phase-locked loops. In 1993 he was elected a Fellow of the Royal Academy of Engineering.

PETER KARLSSON (Peter.C.Karlsson@telia.se) received both his M.Sc. and Ph.D. from the Lund Institute of Technology in 1988 and 1995, respectively. In 1995 he joined the Radio System Group at Telia Research AB, Malmo, Sweden, working on design and analysis of high-capacity broadband radio communications systems. He has been active in the standardization of ETSI HIPERLAN2 and chairs the HIPERLAN2 Global Forum regulatory group. During 2000 he was a research fellow at the University of Bristol in combination with a half-time position at Telia Research. He has written more than 30 papers on mobile and fixed radio systems. He is now an appointed expert in radio communications at Telia Research AB.