

ISSN 0280-5316
ISRN LUTFD2/TFRT--5766--SE

Control of Heating Chamber on Packaging Machine A1 TFA

Hampus Carlsson
Nils-Petter Nytzén

Department of Automatic Control
Lund University
March 2006

Department of Automatic Control Lund Institute of Technology Box 118 SE-221 00 Lund Sweden		<i>Document name</i> MASTER THESIS	
		<i>Date of issue</i> March 2006	
		<i>Document Number</i> ISRNLUTFD2/TFRT--5766--SE	
<i>Author(s)</i> Hampus Carlsson and Nils-Petter Nytzén		<i>Supervisor</i> Pär Olanders, Tetra Pak in Lund Tore Hägglund, Automatic Control in Lund	
		<i>Sponsoring organization</i>	
<i>Title and subtitle</i> Control of Heating Chamber on Packaging Machine A1 TFA. (Reglering av värmelåda på förpackningsmaskin A1 TFA).			
<i>Abstract</i> On the packaging machine Tetra Pak A1 a heating box is used to sterilize the packaging material. This is done by passing the material through a bath of hydrogen peroxide and then vaporizing the liquid in the heating box. The heating is done by three resistive elements that pass their energy by convection and radiation to the packaging material. Problems occur due to temperature variations on the web of the packaging material. During normal production the temperature variations are small and acceptable. At starts and stops, overshoots cause material damages and undershoot results in peroxide residues forcing disposal of packages. This master's thesis proposes how to optimize the control of the temperature. The control will be divided into three stages; start, running and stop. Different conditions during these stages will force the control logic into three different implementations.			
<i>Keywords</i>			
<i>Classification system and/or index terms (if any)</i>			
<i>Supplementary bibliographical information</i>			
<i>ISSN and key title</i> 0280-5316			<i>ISBN</i>
<i>Language</i> English	<i>Number of pages</i> 76	<i>Recipient's notes</i>	
<i>Security classification</i>			

Table of contents

Acknowledgements	3
1. Introduction	5
1.1 About Tetra Laval Group	5
1.1.1 Tetra Pak	5
1.2 Background	6
1.2.1 Aseptic packaging	6
1.2.2 Problem Background	6
1.3 A short description of the main problem	6
2. Problem description	7
2.1 Limitations	7
3. Machine description	8
3.1 Material trajectory through the machine	8
3.2 Heating chamber	10
3.3 PLC-program	11
3.3.1 Current control logic	11
4. Method	13
4.1 Process identification	13
4.1.1 Transient response	14
4.1.2 Frequency response	15
4.2 Design method	16
5. Measurements	18
5.1 First measurements	18
5.1.1 Measurement equipment	18
5.1.2 Results	20
5.2 PLC measurements	24
5.2.1 Measurement equipment	24
5.2.2 Results	25
5.3 Web speed measurements	29
5.3.1 Measurement equipment	29
5.3.2 Results	30
5.4 Step response identification	31
5.4.1 Measurement equipment	31
5.4.2 Results	32
5.5 Frequency response measurements	33
5.5.1 Measurement equipment	33
5.5.2 Result	33

6. Modelling and simulation	35
6.1 Creating a process model	35
6.1.1 Step response identification	35
6.1.2 Frequency response	37
6.2 Bode diagram	39
6.3 Simulink model	40
7. Designing a new control	41
7.1 Choice of PID structure	41
7.2 PID tuning	42
7.2.2 Simulation	43
7.3 Start up control	48
7.4 Stop control	50
8. Implementation	51
9. Validation	53
9.1 Validation of simulation	53
9.2 Validation of start function	54
9.3 Improvement	56
10. Alterations of the TFA A1 200/250	57
10.1 Different package sizes	57
10.2 Different machine speed	57
10.3 Introduction of a fan	58
10.4 Different probe position	59
11. Tuning manual	60
11.1 Measurements	60
11.2 Control design	61
11.3 Implementation	61
12. Summary	62
13. References	63
14. Appendices	64
Appendix 1	65
Appendix 2	67
Appendix 3	70

Acknowledgements

This thesis is developed in collaboration with the Department of Automatic Control at Lund Institute of Technology and Tetra Pak Research and Development. The thesis is the fulfilment of the requirements for the degree of Master of Science in Technical Physics and is written as a cooperative work between two students and constitutes 20 weeks of full time university studies per student.

The work could not be accomplished without all the support from people surrounding us and all of them deserve to be acknowledged.

Firstly we would like to thank our two supervisors, Professor Tore Hägglund, LTH and Pär Olanders, Tetra Pak. Thank you Tore for your positive attitude and for all the help you have provided throughout the work. Special thanks to you Pär for guiding us through our work and at all times providing us with new ideas.

Thank you all at Tetra Pak Research and Development, special thanks to our “roommates” for all presents and surprises.

We would also like to thank Jan Andersson, Hans Korsell, Peter Göransson, Torsten Andersson, Erik Johansson and everybody else at Tetra Pak Carton Ambient for all help and guidance.

Lastly but certainly not least we would like to thank our girlfriends, families and friends for supporting us.

We have had a great time, learned a lot and gained a lot of experience. Thank you all!

Hampus Carlsson

Nils-Petter Nytzén

2006-02-08

Lund

1. Introduction

1.1 About Tetra Laval Group

The Tetra Laval group consists of three independent industry groups, these are; Tetra Pak, DeLaval and Sidel. ^[R.0] DeLaval produces accessories for dairy production and animal husbandry. ^[R.1] Sidel is a manufacturer of filling and blowing machines for PET-bottles. ^[R.2]

1.1.1 Tetra Pak

Tetra Paks main business areas are processing and packaging solutions for food. The company is operating in more than 165 countries with over 20 000 employees.

In Lund, Tetra Pak has a plant for packaging material production, an assembly line for packaging machines and a Research and Development centre with a total of about 2 500 employees. ^[R.0]

Tetra Pak offers a wide range of different packaging solutions, materials and machines as well as processing procedures. Many of the packages come in both aseptic and non aseptic designs. Common for almost every package material is that 75% of it is paper. This provides the strength and stiffness that is needed. To keep the material from leaking and as a barrier against micro organisms a thin layer of polyethylene (20%) is added to both sides. Aluminium foil (5%) keeps the air, light and off-flavours from deteriorating the food. ^[R.0]



*Figure 1.1
Product guide from the Tetra Pak family.*

1.2 Background

1.2.1 Aseptic packaging

With the introduction of aseptic (germ free) packaging principles, Tetra Pak presented a new way of keeping food fresh, safe and flavoured for long periods of time without refrigeration or preservatives. This is done by ensuring that both the food and the packaging material are sterile at the time it is packaged. To ensure sterility the package material passes through a bath of hydrogen peroxide and then it is heated in order to activate the peroxide and finally remove it by evaporation. Sterilization of the product is done by quickly raising its temperature to 150°C for a few seconds. This will kill any unwanted bacteria and it is done just before packaging enclosure.

The packaging material is shaped into a tube which is filled with the product and packages are shaped and sealed below the surface of the liquid. This leaves the package completely full without any air coming into contact with the food.

1.2.2 Problem Background

The hydrogen peroxide bath and heating process is designed differently in different machines. This thesis studies the heating chamber used for sterilization on a Tetra Pak A1 machine. The machine produces the Tetra Classic and Tetra Fino packages. In the A1 machine the packaging material passes through a hydrogen peroxide bath and then enters a heating chamber. Sterilization is achieved when the peroxide is vaporized and the material is heated to about 84°C. These three steps (peroxide bath, vaporization and heat) in combination with exposure time create a sterile material. The sterilization effect is measured in a logarithmic scale called log-reduction.

Heat is created with resistive heating elements that are ordered in three different layers with the material passing between them. To maintain a constant concentration of hydrogen peroxide gas, sterile air is blown in to the chamber at a certain rate.

1.3 A short description of the main problem

The thesis studies the temperature control of the heating chamber. There is a known problem with the control. After a halt in production it is of great importance that the temperature reaches its operational level fast without any over- or undershoots. A halt in the production causes blisters on the packaging material since the temperature difference in the chamber between production and pause is too large. These blisters seriously damage the material and the produced packages have to be destroyed.

2. Problem description

The specific control problem with the A1 machines sterilization unit, the heating chamber, is the overshoots during start-ups. These start-ups cause variations in the amount of peroxide residue as well as material damages on the finished package, therefore disposal is necessary. During normal operations, i.e. the machine is running, the web temperature should be maintained at 84°C. (Web refers to the surface of the packaging material) Typical temperature variation of the web during a start and normal operation is shown below in figure 2.1.

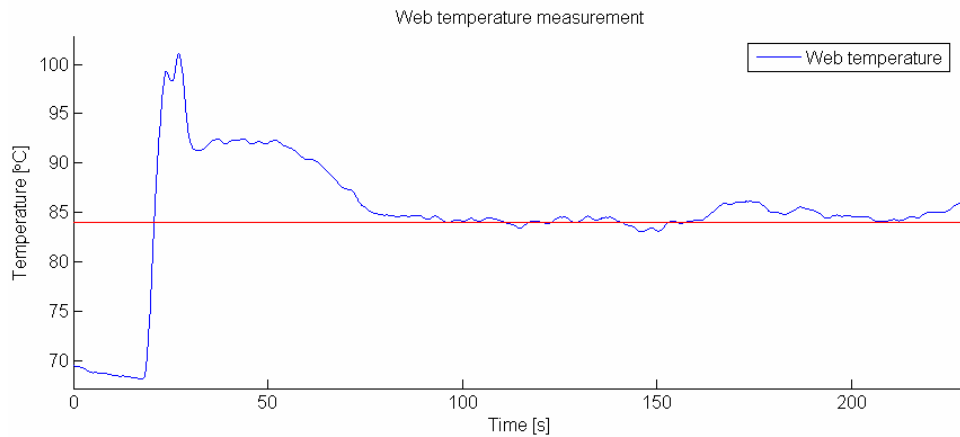

Figure 2.1

Web temperature during a start, the machine is started at $t \approx 20s$

As seen in the figure, a production start results in the web temperature to peak during the initial 13 seconds. After the initial 13 seconds the web temperature decreases into a small dip and after this rising slowly for a couple of seconds. The temperature is then lowered until it reaches its designated set point of 84°C. The total time that the web temperature is above the desired set point varies from start to start. Once the machine reaches the operational temperature small, but acceptable, deviations occur.

It is desired that the temperature overshoots following a start as well as the deviations during operations are reduced to a minimum.

2.1 Limitations

This thesis studies if it is possible to control the heating chamber and the web temperature in a more satisfying way. It is not a study of how a new sterilization system should be designed instead it proposes how the current system could be optimized. Any physical configurations of the chamber must be financially motivated so that the added production cost is covered by substantial gains to the product.

3. Machine description

To fully comprehend the complexity of the problem it is essential to have a basic knowledge of how the machine works in general. Customers of the A1 platform will position the machine in direct connection to the dairy production facility. The product is fed through pipes and connected to A1. The produced packages exit the machine on a conveyer belt distributing the packages to further loading.

3.1 Material trajectory through the machine

Packaging material is delivered to the machine in rolls of different widths. The rolls are mounted to the machine so that they can easily rotate. The material is then pulled through different rollers constituting a buffer so that material can be changed without production stops. After this a longitudinal seal strip (LS strip) is applied on one side of the material and is used to cover the carton edge when the tube is formed. The LS-strip is attached by heating the material side as well as the strip itself making them stick together. The LS-strip consists of a thin roll feed plastic strip that also passes through a buffer enabling roll change without disturbing production. After the plastic seam is attached, the material path is altered by different rollers so that the material enters the hydrogen peroxide bath. The hydrogen peroxide bath acts as an air lock to the pressure chambers that follow the peroxide bath. This ensures that no germs will come in contact with the package material from this point on.

Two calender rollers apply pressure to the packaging material mangling off the excess peroxide so that a thin and consistent layer of peroxide is sustained when the material enters the heating chamber. The effective path through the heating chamber is tripled by bending the material on two rollers thus increasing the sterilization and vaporization effect. Further description of the heating chamber can be found in section 3.2. As the material exits the heating chamber it is at the highest point of the machinery as it bends of a roller entering the filling tower. This is where the material is formed into a tube and the longitudinal seal is done by sealing the LS-strip and the material edges together.

Both the heating chamber and the filling tower are over pressurized, ensuring that a leak in the compartment will not allow micro organisms to enter the sterile environment. The excess air from the heating chamber and the filling tower is released through a chimney where the two meet. The product filled tube leaves the filling tower and the packages are shaped and sealed beneath the liquid surface making the packages air free. All this is done at a speed of 0.4 meters per second rendering the total time from the roll to finished product of 35 seconds.

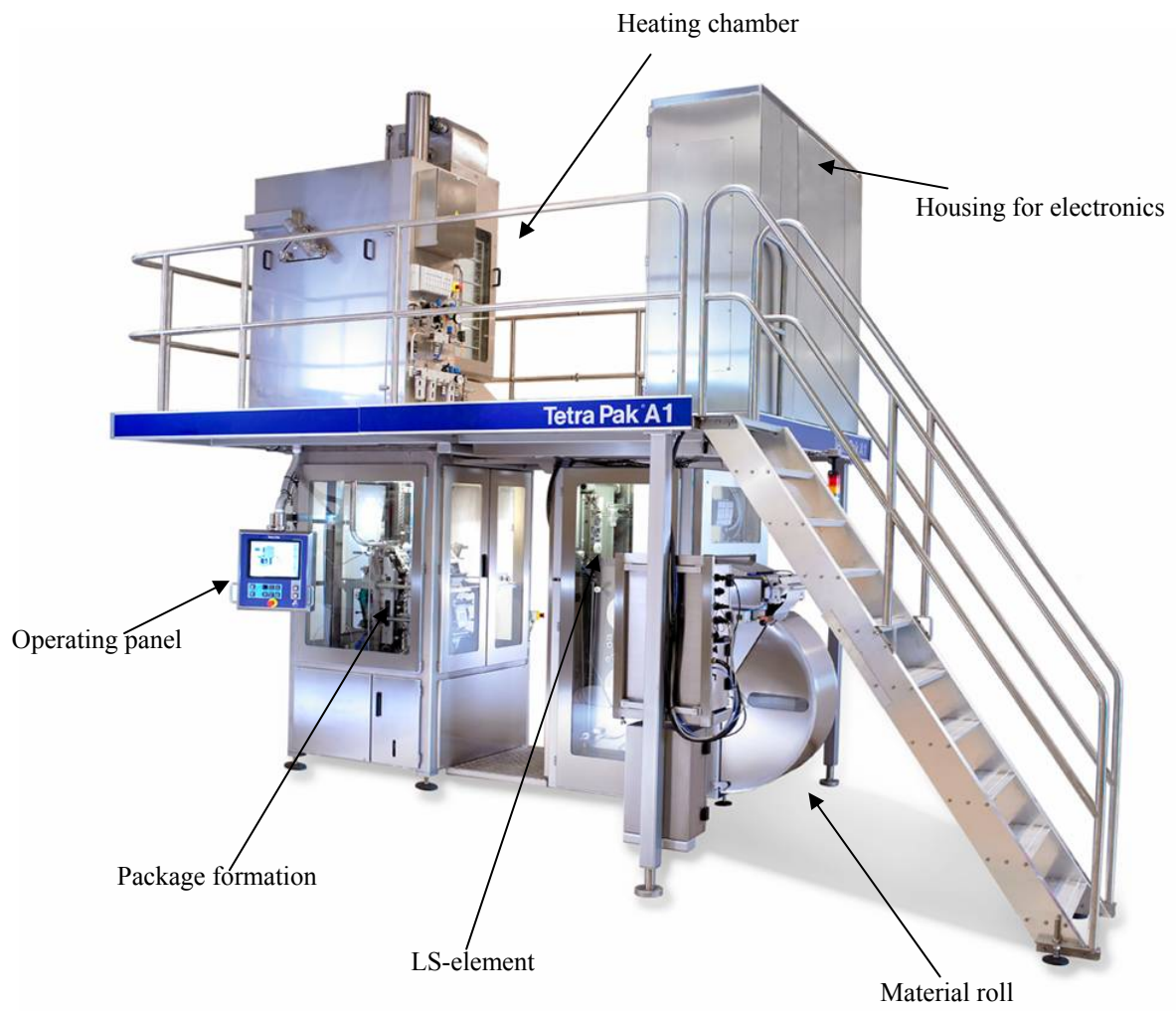

Figure 3.1 a
Picture of the Tetra Pak A1 machine and highlighted parts.



Figure 3.1 b
The heating chamber opened and closed.

3.2 Heating chamber

After the material has passed the two pressure rollers following the peroxide bath it enters the chamber through a thin slit. In the chamber the material will pass between the three heating elements bending on rollers as seen in figure 3.2. The heating elements are composed of a thin stainless steel net connected in series so that heat is received as current flows through them. The heat is emitted to the web by means of convection and radiation, the main energy transport is convection.

In the chamber there are several inlets for sterile air, marked with dots in figure 3.2. The air flow into the chamber is controlled manually by a valve and monitored by a flow meter. It is controlled so that the air flow into the chamber is within fixed limits, holding the gas concentration at a desired level as well as sustaining a higher pressure than its surroundings. There is however at present no way of measuring the peroxide gas concentration. A secondary effect of letting the air flow through the inlets is that it will increase the overall flow and therefore increase the energy exchange.

There is a probe for air temperature measurement located near the middle heating element. This is used as feedback during production halts to maintain a desired temperature of 98°C. This temperature was once found to give best conditions for the start i.e. lowest level of residues in the first packages. Further attempts to optimize this temperature have not been performed. When a production halt occurs the packaging material may blister since the temperature of the heating elements can't be lowered fast enough. The input of energy is many times higher during operation than during halt. Due to the blisters, a certain amount of material must be rejected in order to avoid faulty packages to be produced. The blisters compromise the quality of the product and may damage the surface temperature probe leaving plastic remains on it.

At the top of the chamber the material exits into the filling tower. Here is a surface temperature probe measuring the temperature of the web. This temperature is used as feedback to the control loop regulating the chamber when the machine is running. The control loop consists of a PID-controller with a set point value of 84°C. At this web temperature the residue of peroxide is within limits and the sterilization effect is very high. It takes about 8 seconds for the material to pass through the heating chamber since the speed is 0.4 meters per second and the effective length of the chamber is about 3.2 meters. In this time the web temperature must rise from its initial temperature to the desired 84°C, this is achieved through the control algorithm holding the chamber temperature at about 140°C depending on the heat capacity of the material and the air flow in the heating chamber.

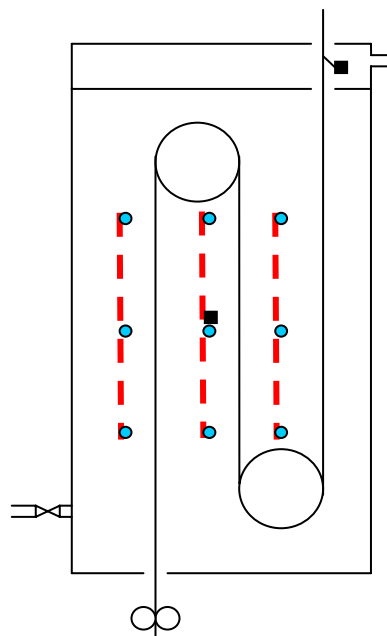

Figure 3.2
Material path through the chamber.

3.3 PLC-program

The control and logic of the A1 machine is implemented on a PLC (Programmable Logic Controllers) using the IEC 61131 standard program language called Ladder Diagram. The program is written and monitored through a program called Logic Master Series 90-30.

The CPU (Central Processing Unit) operates in a cyclic pattern where the following seven steps are executed in a standard sweep mode. The CPU sweep time is the total execution time of the seven steps where the program logic often constitutes the longest time.

1. Start-of-sweep housekeeping
2. Input scan (read inputs)
3. Application program logic solution
4. Output scan (update outputs)
5. Programmer communications
6. System communications
7. Diagnostics

When in housekeeping the CPU performs necessary tasks to prepare for the start of the sweep. If the PLC is in constant sweep mode the start is delayed until sufficient time has passed. When the start sequence is done the inputs are scanned and the discrete (%I) and analogue (%AI) memory is updated. The program logic occurs directly after completion of the scan sequence and performs two main tasks; solving/executing the program logic and updating the output memory. The outputs are scanned following the logic part. Outputs are updated according to the output memory, %Q for discrete output and %AQ for analogue. If there is a programmer attached, communication with it occurs during the communication sweep. In system communications information to and from any intelligent option modules are sent. Requests are serviced on a first-come-first served basis. During the diagnostic part the CPU checks the actual hardware against the configuration and any changes are updated at this time. ^[R.3]

3.3.1 Current control logic

To be able to fully understand the outcome of the measurements on the system it is essential to have a basic knowledge of how the current control logic is implemented.

The current configuration sets the sweep time of the PLC's CPU to 30ms. In this time all of the machine's inputs, control logic and outputs are scanned, calculated and updated. Temperature in the heating chamber is controlled by passing current through the three resistive heating elements. The control signal is calculated by either PID controllers, or pre-pro-

grammed values implemented in the PLC. The PID sets a control value between 0-32000 once every 100ms. This value, after divided by 32, is compared with a counter that counts to 1000 during one second. If the control value (now between 0-1000) is greater than the incremented timer value, the output to the heating elements is turned on (10V). This signal is then passed through a solid-state relay amplifying it to 24V. This means that the signal to the elements is controlled by an on-off signal, either 0V or 24V once every 30ms.

The logic is divided into four parts; start up, pre-programmed sequence, normal operation and halt as described below.

Start up

When the machine is turned on for the first time (after a night's stop) the whole machine goes through a sterilisation process. Hydrogen peroxide is sprayed through the filling tower, heating chamber and the peroxide bath. Hot sterile air is blown through the system and the peroxide is vaporized. The chamber temperature is controlled to 98°C by the PLC's PID, and this warm up and sterilisation period takes about one hour.

Pre-programmed sequence

When the operator starts the production a pre programmed start sequence is executed. First there is a check to see that the chamber temperature is below 110°C, otherwise it is not allowed to start. The power to the elements is set at a constant value for the first 20 seconds, after this it is gradually decreased until the web temperature comes below a pre set temperature. At this point the temperature control is handed over to the PLC's PID.

Normal operations

During normal operations, after the pre-programmed sequence, the PID controls the temperature to a steady 84°C. It is maintained there during the production to ensure that the material is sterilised and that the peroxide residue is minimal.

Halt

During production halts or machine initialisation the chamber temperature is controlled to 98°C. When a production halt occurs, the main drive motor abruptly stops, causing the material to be exposed to the operational conditions of the heating chamber, about 140°C. At this point a pre programmed sequence cuts the power to the heating elements as long as the inner temperature is above 105°C. As the temperature sinks below 105°C a PID-controller takes over and controls the temperature to 98°C. It is because of these abrupt stops and the high working temperature inside the chamber that the packaging material sometimes blisters. ^[R.4]

4. Method

A proper problem solving approach used in control theory is divided into three major steps. First, measurements are performed in order to identify the system. Secondly, a control design is derived from the identified system and thirdly, the new control is implemented and tested.

4.1 Process identification

It is important to get a physical comprehension of the process before using any identification tools. The number of physical inputs and how they affect the system are of great importance to the identification process. The means of energy transportation and how it is changed due to modifications in the process gives great help for understanding the controllability of the system. When enough information is gathered about the system, the choice of identification procedure is determined by the complexity of the system.

Initial experiments such as logging of data during normal operations give a good idea about the measurement problems that arise when measuring the different signals such as:

- Sampling speed. The sampling frequency should be greater than the Nyquist frequency to avoid aliasing.
- Signal to noise ratio.
- Linearity region.
- Physical limitations and saturations.
- Rise time. It is important to know the maximum rise time of measurement equipment so that it can be compared with the rise time of the system.
- Probe accuracy and influence.
- Data logging and storing. The amount of data grows rapidly when using a high measurement frequency and this might compromise the ability to read information from it. Programs like Microsoft Excel for example can only handle 65 536 measurement points.

These problems should be taken into consideration when selecting measurement device and planning of further tests. The dominating time delays and time constants can be evaluated from step responses as well as the causal relationship between inputs and outputs. From this information a second stage of experiments should be derived where the linearity, time

invariance and noise conditions of the system should be considered. The choice of input e.g. step functions in transient analysis, sinusoids in frequency response and PRBS (Pseudo Random Binary Sequence) in correlation analysis all have to fulfil the sufficient excitation criteria, meaning that the signal should contain enough information to excite the interesting parts of the system. The amplitude of the signal should be chosen so that it has a good enough signal to noise ratio without entering a nonlinear region. ^[R.5]

4.1.1 Transient response

Identification through signals like impulse and step response are often easy to apply and give a good enough estimate of system gain, time constants and time delays for simple systems. High frequency properties, saturation and nonlinearities are some of the problems arising when using transient response.

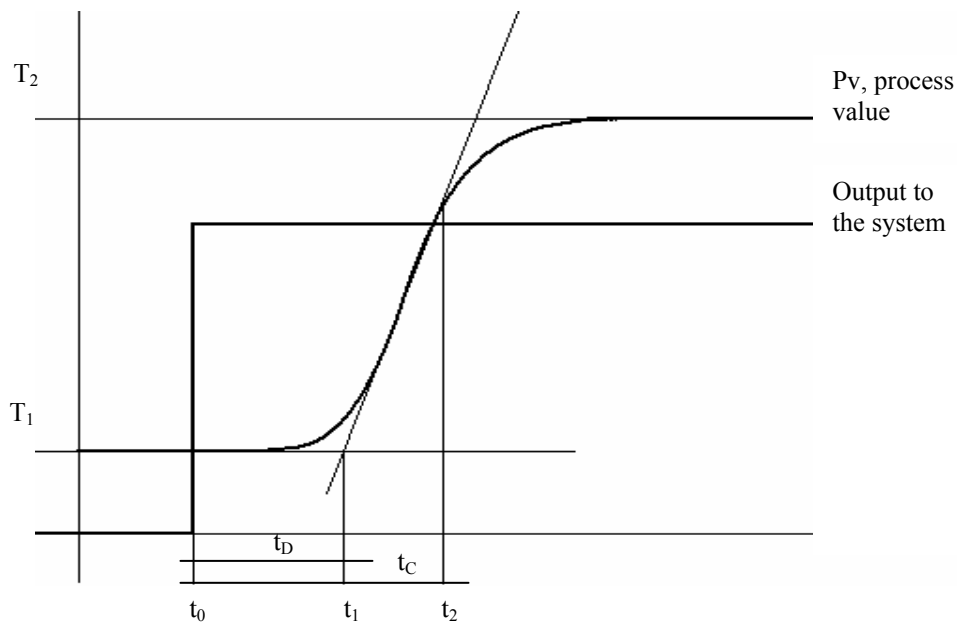

Figure 4.1

A process can be approximated by a simple first order system calculated from the t_D , t_C and process gain

The step response experiment should be performed on the open loop system; this means that no controller with feedback is used. Any constraints on the output such as minimum slew time should be removed so that a perfect step in the control signal, feeding the system, is achieved. When the process value and the output are plotted a figure like 4.1 is attained. From this a simple first order system can easily be calculated from the process gain K , the process dead time t_D and the process time constant t_C .

$$\frac{PV(s)}{CV(s)} = G(s) = K \frac{e^{-t_D s}}{1 + t_C s}, \quad K = \frac{T_2 - T_1}{CV_{step}} \quad \text{Equation 4.1}$$

The process time constant is defined as the time it takes for the process to reach 63,2% of the step. ^[R.6]

4.1.2 Frequency response

In order to generate a more accurate model of the system a method called frequency response analysis can be used. This method uses a sinusoidal signal with different frequencies and constant amplitude to identify the systems gain and phase shift.

When feeding a stable system with a sinusoidal signal, $u(t)=u \sin(\omega t)$, the steady state response, $y(t)$, is characterized by the gain $|G(i\omega)|$ and the phase shift $\Phi(\omega)$, that when plotted against the frequency form a bode plot.

$$y(t) = |G(i\omega)| u \sin(\omega t + \Phi(\omega)); \Phi(\omega) = \arg G(i\omega) \quad \text{Equation 4.2}$$

A way of calculating the gain and phase shift of the system is to let the output of the system be multiplied with sinusoidal's and integrated during the specified measurement interval T, se figure 4.2.

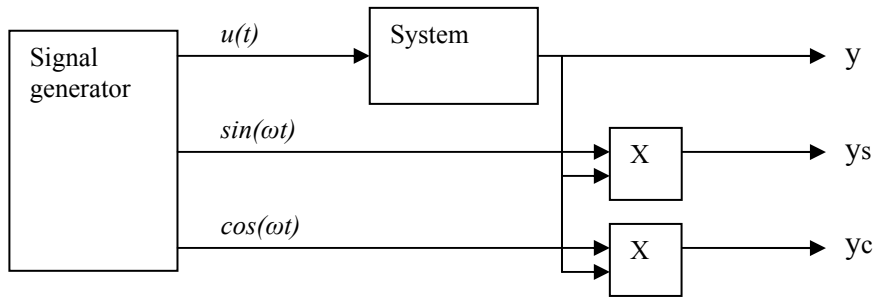

Figure 4.2
Signal routing for calculations of gain and phase shift.

The measurement duration T should always be an integer, k , of full periods, this to minimize the disturbance which gives $T = k (2 \pi / \omega)$. The calculations of the sine and cosine channel are performed as follows:

$$s_T = \int_0^T y(t) \sin \omega t \, dt = \frac{1}{2} T |G(i\omega)| u \cos \phi(\omega) \quad \text{Equation 4.3}$$

$$c_T = \int_0^T y(t) \cos \omega t \, dt = \frac{1}{2} T |G(i\omega)| u \sin \phi(\omega)$$

The estimates of gain and phase shift are obtained by:

$$|G(i\omega)| = \frac{2}{T \cdot u} \sqrt{s_T^2(\omega) + c_T^2(\omega)} \quad \text{Equation 4.4}$$

$$\phi(\omega) = \arctan\left(\frac{c_T(\omega)}{s_T(\omega)}\right) + k\pi$$

The frequencies examined should reflect the working area of interest so that the desired bode diagram is attained. [R.5]

Matlab Identification Toolbox provides a way to build and evaluate linear models from input to output data. Data pre-processing such as removal of bias and linear trends, filtering and removing outliers can be done using graphical interface. Model estimation is conducted through parametric estimation, process model estimation or nonparametric estimation. The attained models can be imported into Simulink software and the system can be simulated. [R.7]

4.2 Design method

To control the system, PID controllers provided by the PLC makers GE Fanuc will be used. Once a first order system is identified the controllers can be tuned using different schemes, two of these described below. These schemes provide good initial values for the P, I and D settings of the controller.

The mathematical expression for the PID-controller in standard form is given by:

$$u(t) = K_C \left(e + \frac{1}{T_i} \int e(t) dt + T_d \frac{de}{dt} \right) \quad e = (sp - pv) \quad \text{Equation 4.5}$$

Parameters of the PID-controller can be estimated using Ziegler-Nichols method or lambda tuning.

Ziegler-Nichols method:

Controller	K_c	T_i	T_d
P	$\frac{t_C}{K \cdot t_D}$		
PI	$0,9 \cdot \frac{t_C}{K \cdot t_D}$	$3 \cdot t_D$	
PID	$1,2 \cdot \frac{t_C}{K \cdot t_D}$	$2 \cdot t_D$	$0,5 \cdot t_D$

Equation 4.6

Lambda tuning for a PI- controller:

$$K_C = \frac{t_C}{K(t_D + \lambda)} \quad T_i = t_C \quad \text{Equation 4.7}$$

Ziegler-Nichols way of calculating the parameters only present one way of tuning the PID controller. With the lambda tuning method it is possible to choose whether the controller should behave in an aggressive or defensive way by the choice of lambda, λ . To calculate lambda a lambda factor is introduced as:

$$\kappa = \frac{\lambda}{T_i}$$

Equation 4.8

If $\kappa < 1$ the PI-controller will be aggressive and if $\kappa > 1$ it will be defensive. With an aggressive tuning the controller will bring the process value to the desired set point faster than the process step response. The downside with an aggressive tuning is that it may lead to self-induced oscillations. ^[R.8]

Simulation of the identified system gives an easy way of calculating and testing different control strategies, thus increasing the understanding of the problem. Simulink enables analysis on dynamic systems. For Simulink to simulate the process a graphical model has to be created. With the model Simulink depicts the time dependent mathematical relationships and the system can be simulated over a specified period of time. ^[R.7]

5. Measurements

Process identification relies on the ability to measure the signals and the physical parameters controlling the process. This can be done with different kinds of measurement tools. The sampling interval and noise sensitivity are some of the parameters that must be taken into consideration before selecting equipment.

5.1 First measurements

To gather basic knowledge of the system measurements of the inputs and outputs of the system were performed. Measurements were done both in stop and running mode and the results are analyzed in the following sections. The placements of the measurement probes are shown in figure 5.1.

Point 1 shows the original web temperature probe and point 2 the original chamber temperature probe; these are the measured outputs of the system. Points 3-5 symbolizes the signal to the element, i.e. the inputs to the system.

Additional measurements were carried out at the points showed. Points 7-10 shows where the additional web temperature measurements were performed. At point 6 one of the new probes was mounted next to the existing one so that the new probes could be verified. Point 11 measured the air temperature at the top of the chamber and finally the outside temperature was logged at point 12.

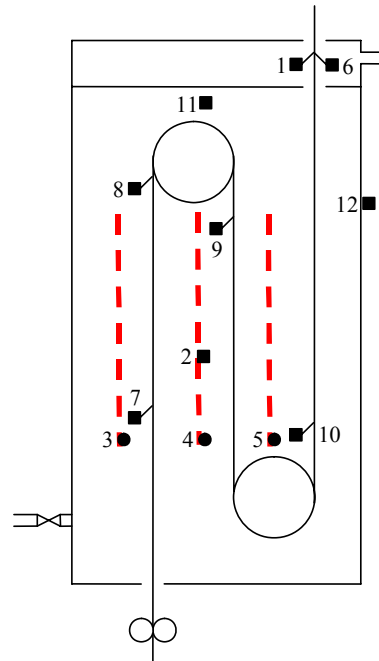

Figure 5.1
Measurement points within the chamber

5.1.1 Measurement equipment

Measurement readings were extracted using a Hewlett Packard System. Temperature readings were done by specially designed probes connected to a HP 3852A Data acquisition/control unit. This unit was controlled by the program Agilent VEE 6 running on a Dell Workstation 400 Pentium II which enabled real time observation of the collected data as well as measurement logging to a file. The different types of measurement probes were connected through wires to a HP 44713, 24 channel high speed FET multiplexer with thermocouple compensation.

No existing surface measurement tool for temperature was found small enough to fit into the heating chamber at the given measurement points, a new had to be constructed. A very thin metal plate was constructed so that it was in direct contact with the material as the web passed the measurement point. On the metal plate a thermal wire (type K) was attached, the wire registered the temperature, see figure 5.2.

To evaluate this measurement probe it was mounted next to the original web measurement probe.

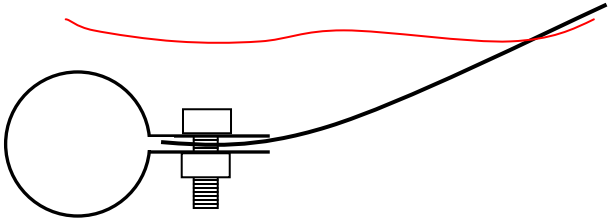

Figure 5.2
The constructed web temperature probe with its attachment ring and bolt.

5.1.2 Results

Figure 5.3 shows the two web temperature measurement points 1 and 6, the existing one versus the new. The probes registered an offset of about five degrees between them; the new gave a higher value. Apart from this they seem to behave almost identical.

The plot shows a start and a stop of the machine. At $t \approx 4170$ s the machine was started; the web started to move and the chamber elements was switched on. The registered web temperature rose fast and peaked at about 100°C . After this high overshoot the temperature decreased to about 90°C and then slowly descended to the desired web temperature of 84°C . The web temperature reached 84°C after about 60s.

The first peak, the one that reached 100°C , originates from the material that was at a halt inside the chamber during the stop. At a stop, material within the chamber will be heated to the same temperature as the chamber, i.e. $98 - 110^\circ\text{C}$. When the machine starts, this material exits the chamber, which the web measurement probe displays. The length of this overshoot in time is about 11s. This time should be compared to the amount of material that is inside the chamber during a stop which is 3.40m (length of material) / 0.4 m/s (machine speed) = 8.5s . If the time of the overshoot is only measured until the temperature starts to drop the 11s will decrease to about 8-9s. This will be studied in greater detail in section 5.3, measurement of web speed.

The second, longer and lower, overshoot originates from the control of the elements. Any further conclusions about this can not be drawn unless compared to the control signal to the elements. This will be done later.

When the machine was stopped, at $t \approx 4400$ s, the temperature dropped due to two different effects. The first since no new hot material is fed to the probe and therefore the probe cools down to the surrounding temperature. The second contribution to the temperature drop is that the air temperature in the small compartment where the web probe is installed also will cool down. This since the air entering this space comes from the chamber and the chamber temperature decreases during a stop.

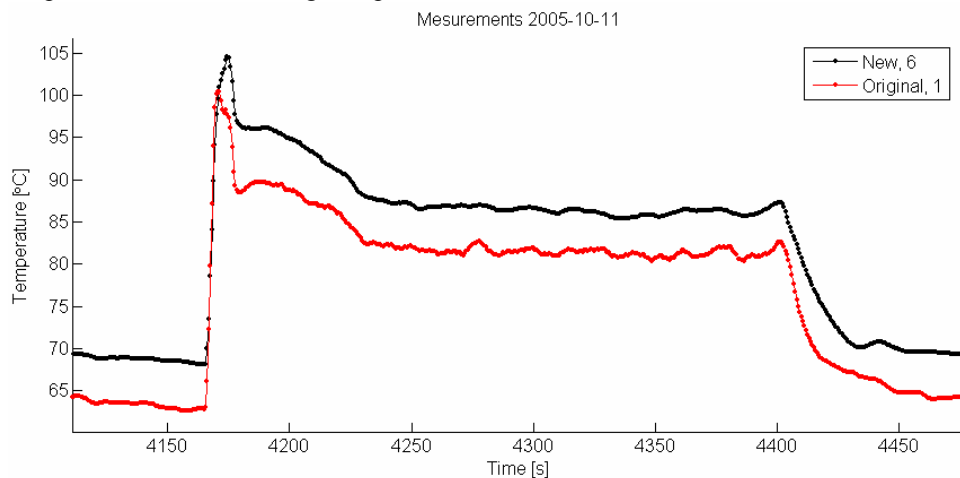

Figure 5.3

Comparison between original and the new measurement probes, situated at the top of the chamber, during a short production run. The new probe resulted in a higher temperature.

Figure 5.4 shows the two air temperature measurement points inside the chamber, 2 and 11. The machine is started at $t \approx 4800$ s and stopped at $t \approx 5100$ s.

The difference in the signals was not only of offset character. Since the original probe was exposed to direct radiation from the elements and the new was not. When the machine was started the original probe peaked in the beginning and then settled down at about 30°C above the start temperature. The new probe only increased about 10°C without any overshoot. The different behaviour is due to the direct radiation and the fact that they were mounted at different locations. The original probe measured the chamber temperature plus the radiation effect and the new only measured the increase in chamber temperature.

The original probe has two different characteristics in the cool down flank after a stop. The fast decrease in temperature can be explained by removal of direct radiation as the elements are switched of. The slow temperature drop is because of the material cooling down by convection. Finally the temperature is so low that the control switches the elements back on to maintain a temperature of 98°C .

The difference in temperature registered by the two probes during a stop is due to their different locations, studied deeper in section 5.3.

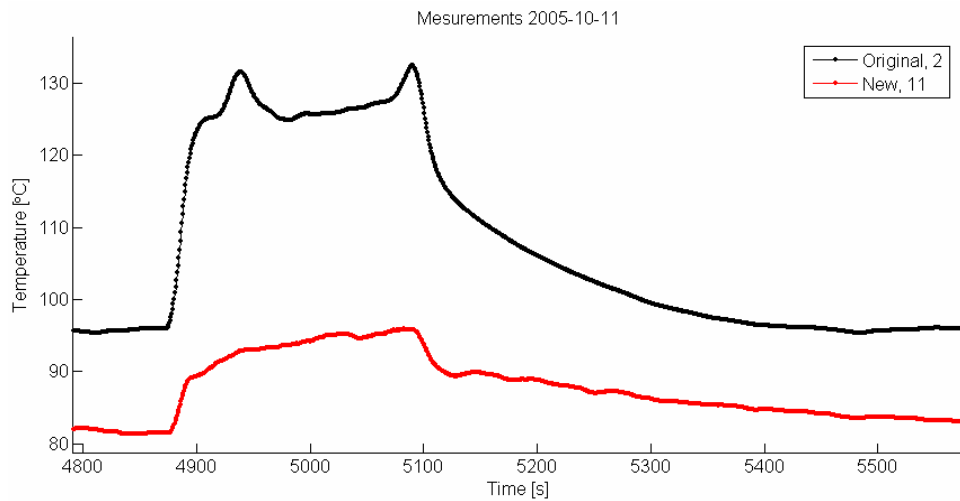

Figure 5.4
Comparison of the temperature readings from the original and the top chamber temperature probes.
The new rising to over 130°C .

Figure 5.5 contains readings from points 7-10. The machine was started at $t \approx 4890s$ and stopped at $t \approx 5100s$. The result from this measurement very much shows the effect of radiation from the elements. Point 7, the one that measured the web temperature where the material entered the chamber gave a reading of about $96^{\circ}C$. The material is about $20^{\circ}C$ (room temperature) when it enters the chamber and therefore it is not realistic that the temperature has increased $76^{\circ}C$ in such a short time.

The only measurement point not installed in direct radiation contact with the elements was point 8, so this reading should be more correct, but it is not logical that the point after (point 9) gives a lower value since this probe was exposed to radiation. The result from these probes, when the machine is running, is not considered to be very reliable.

More trustworthy are the readings from when the machine was stopped, the radiation was much lower due to lower power supply to the elements. Points 7 and 10 that were positioned low in the chamber gave higher temperatures than points 8 and 9 that were mounted high up. Point 8 gives about the same temperature as point 11 when steady state is reached. Point 2 was also close to points 7 and 10 in the geometry and they gave a similar temperature reading. From this the conclusion is that the temperature is higher in the lower end of the chamber during stops.

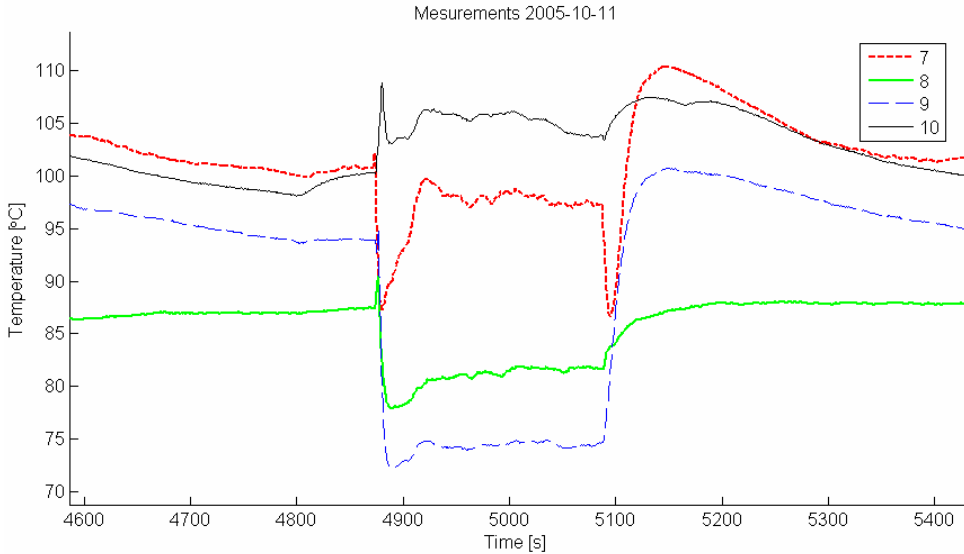

Figure 5.5

Variation of the web temperature from the inlet to the outlet of the chamber, measurements 7-10. The machine was stopped at $t \approx 4880s$ and started again at $t \approx 5100s$.

Figure 5.6 shows the logging from the three solid-state relays. The purpose of this measurement was to determine the input signal to the process, but from the plot it is obvious that this is not possible. The only conclusion that can be drawn is whether the elements were switched on or off. The signal to the solid-state relays is a signal that is on for a part of a second and then switched off for the remaining part of the second. This behaviour is repeated every second and in this way the power to the elements are controlled. In the PLC the control signal to the elements is calculated by controllers to a value between 0 and 32000 and this is the signal that was intended to be measured. The result from this measurement shows that the output from the controllers (input to the system) is not measurable unless the sampling frequency is really high; > 1000Hz or the signal is extracted directly from the PLC.

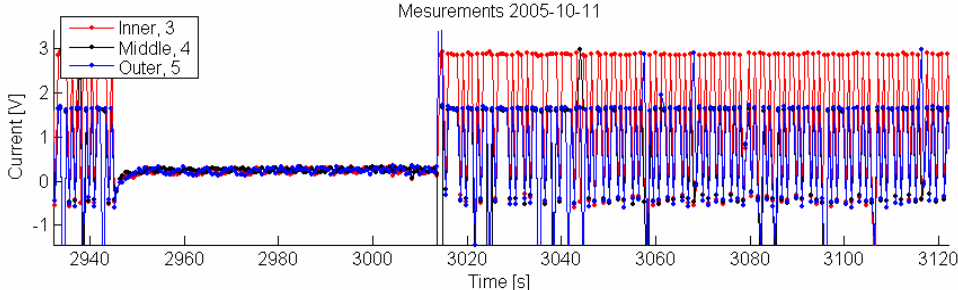

Figure 5.6

The on off signal to the heating elements sampled at 3Hz. From the result it is only possible to determine whether the elements were turned on or off.

Figure 5.7 shows the two original probes that measured the chamber and web temperature. When the machine is running the web temperature has the same characteristics every time. First there is the overshoot due to the material that has been inside the chamber and then the overshoot due to the control of the elements.

The chamber temperature does not behave in the same controlled way when the machine is running; the temperature varies over 50°C. When the machine is stopped the chamber temperature behaves as expected; it cools down as previously explained and is controlled to 98°C.

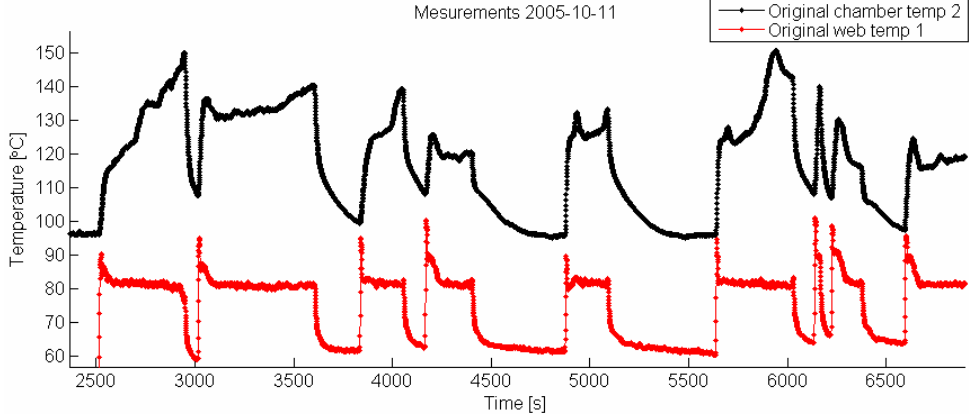

Figure 5.7

The original web and chamber temperature probes showing production starts and stops.

Figure 5.8 shows the outside temperature of the chamber. The vertical line indicates where production started for the first time, everything before this line is preparations of the machine such as sterilization and so forth. The temperature reaches steady state at about 63°C.

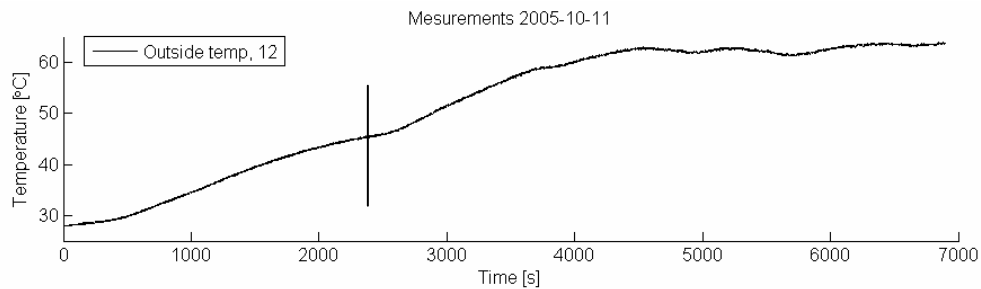

Figure 5.8

The chamber material increases from room temperature to a production temperature of about 63°C.

5.2 PLC measurements

The above mentioned problem, measuring the discrete signal from the solid-state relays, could be solved by measuring the control signal directly from the PLC. Before the signal is converted into a discrete sequence in the PLC it is a value between 0-32000 (described in section 3.3.1 about the PLC). This value could be measured using an analogue output from the PLC connected to the logging device. Since the control signal is calculated by one PID-controller during stop, another PID-controller when the machine is running and a sequence consisting of three different signals, one for each element, during start all these signals were logged. Moreover the web and chamber temperatures measured by the PLC were logged as well as a control signal showing if the machine is in stop, start or running mode.

During the measurements the machine was stopped and started several times with varying lengths of the stops so that the initial temperature of the chamber varied between 98 – 110°C.

5.2.1 Measurement equipment

To avoid any conflicts with the currently used configuration of the PLC a new analogue output card was installed on the PLC rack. The outputs from the card were logged using a USB-based Personal Measuring Device, PDM-1208FS, connected to a personal computer running HP-VEE 6.0 where the logging was performed.

5.2.2 Results

Figure 5.9 shows a measurement where the machine was started at $t \approx 1910$ s with 98°C as initial chamber temperature.

As seen in the figure the web temperature has the same characteristics as before, a high overshoot in the absolute beginning and then the slow movement towards the set point of 84°C .

The control signal to the elements during the start of the machine is generated by a pre programmed sequence that is executed at every start, explained in section 3.3.1.

The pre programmed sequence is executed until certain conditions are fulfilled; this is marked by the vertical line. After this a PID-controller strives to control the web temperature to the desired set point until the machine is stopped again.

When the machine is started the pre programmed sequence is set to a fix value of 23200 for all three elements. After 20 seconds the signal starts to ramp down and this will continue until the web temperature is less than 86°C and at least 30 seconds has passed. The slope of the ramp is decided by a logic check that is executed every second, this check is comparing the time passed with the web temperature and tries to adapt to this.

At the vertical line the sequence hands over to the PID-controller. This controller is, when the machine is started, set to its maximum value, 27000, for 2 seconds and then let free. This controller then tries to control the process but its output is not connected to the elements until the start sequence has ended.

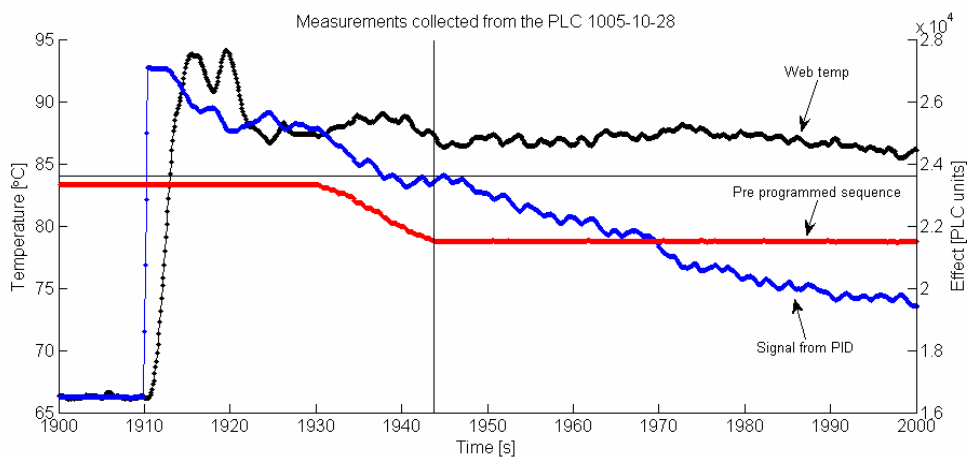

Figure 5.9

In this measurement the difference between the controllers output and the pre-programmed sequence causes the temperature to rise when the PID-controller receives the control.

Figure 5.10 shows a start of the machine when the chamber temperature was 110°C, as high as it is allowed to be. Noticeable differences between this and the previous start are that the temperature overshoot for the web is larger and that the control signals is somewhat different. In the beginning the pre set control value is the same as the previous start. The following ramp down of the element is longer and it changes the gradient for the inner element at the end. This shows how the logic check discovered that the web temperature was higher and how the signal tried to compensate for this.

The output from PID-controller also shows another phenomenon, the effect of minimum slew time. In the controller a value called minimum slew time is set to 50 seconds, this means that the maximum rate of change is 32000 units in 50 seconds. This gives that $32000 \text{ units} / 50 \text{ s} = 640 \text{ units/s}$ is the biggest change of the control signal. The PID-controller was again set to 27000 for two seconds at the start of the machine and then decreases since the temperature is too high. Now the controller wanted to decrease its output faster than the minimum slew time allowed and therefore the signal decreases as a ramp with the gradient 640 units/s. At $t \approx 985 \text{ s}$ yet another effect in the configuration of the PID-controller showed. The PID-controller has a lower clamp at 14700 units during the start sequence, this was what the controller reached and therefore the calculated output (not the actual output) stayed constant at this level until the start sequence ended at the vertical line. The lower clamp is then set to zero until the next stop. These effects do not have any influence on the actual power to the elements during the start, since the signal from the PID-controller is not used.

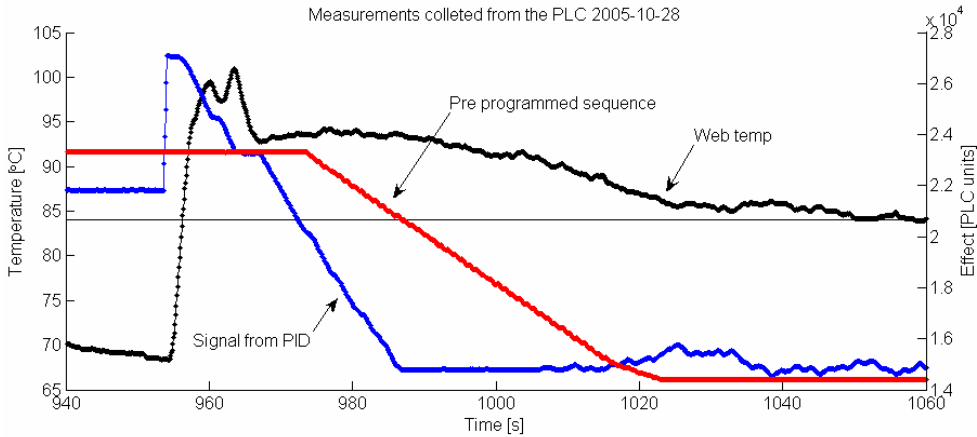

Figure 5.10

The difference between the controller output and the pre-programmed sequence is not as large as before, see figure 5.9.

Figure 5.11 shows as previous the web and chamber temperature and the control signal to the elements. The difference is that the two signals (pre programmed sequence and output from PID) have been put together to one signal showing the actual output to the elements.

As before the start sequence first runs and then the controller takes over at the vertical line. Here it is obvious that there is a mismatch between the two signals when the mode, start to running, of the machine is changed. The actual output to the elements does a discrete jump when the mode changes so that the power is actually increased when it really should be lowered in order to reach 84°C. An effect of this discrete jump can be seen in the figure on the web temperature. When the mode changed from sequence to controller the temperature was descending towards the set point quite fast. The power to the elements increased to where the ramping started and therefore the temperature gradient increased making the overshoot linger.

The difference between the signals can very well be the other way around so that the discrete step decreases the power to the elements. This is often preferred since the temperature always is above 84°C.

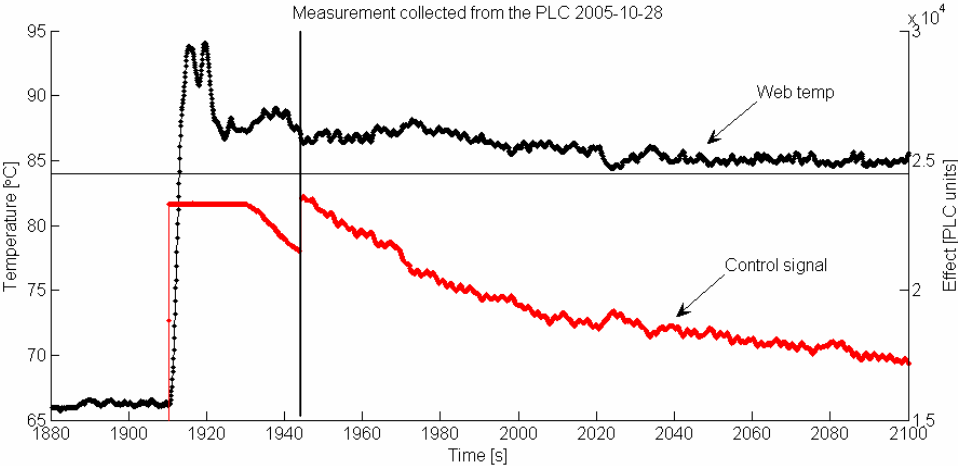

Figure 5.11
The discrete output step and its effect are clearly visible in the figure.

Figure 5.12 shows the control of the element when the machine was stopped. The elements are now controlled by a PID-controller with different settings than the one controlling the elements when the machine was running. This PID-controller controls the temperature of the chamber and has a set point of 98°C. When the machine was stopped the chamber temperature was way above 98°C and therefore the PID-controller remained at zero until the temperature came near the set point. The signal from the PID-controller grows and finally holds the temperature at 98°C. The high production temperatures of the chamber (130°C) and the slow disperse of energy makes the total time until the chamber temperature is under 110°C to about 2 minutes.

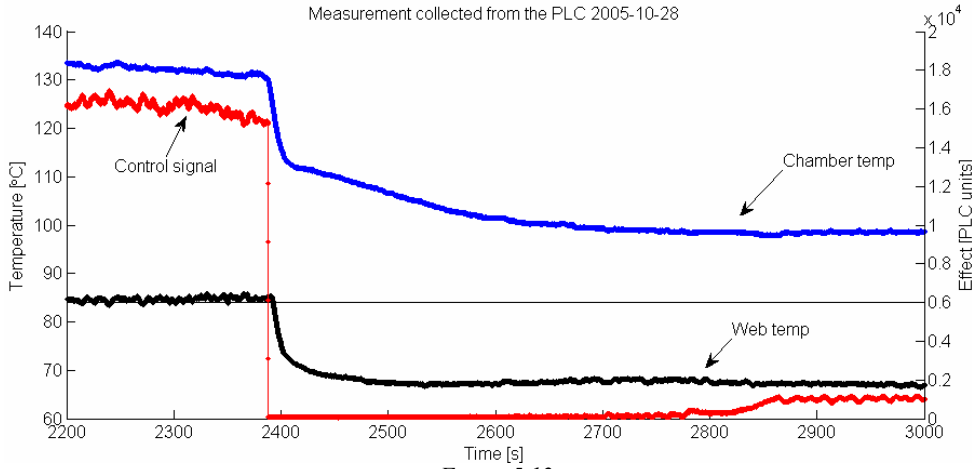

Figure 5.12
The control holds the desired chamber temperature at 98°C

During measurements it was, by accident, discovered that the system is sensitive to leakage from the sterilization and filling compartments. A hatch locking device was left open and the temperature behaved differently. Due to this glitch air escaped to the surroundings directly from the filling tower, not exiting through the chimney and therefore not passing the small space housing the web probe. Closing and opening the locking device generated the following figure, showing the systems sensitivity towards air leakage. A glitch produces the lower values of the “square form” in the control signal. Due to the design of the web probe it is hard know whether it is the temperature of the material or of the air that causes these variations. One theory might be that the flow of cooler tower air into the small compartment, where the probe is situated, is reduced when the glitch is present. Thus increasing the compartments temperature and affecting the web temperature reading.

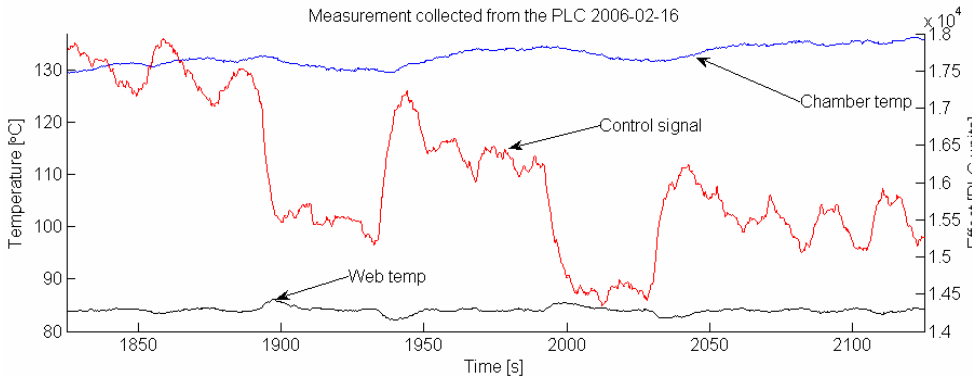

Figure 5.13
Control signal and temperature variations due to air leakage from the filling tower.

5.3 Web speed measurements

As mentioned the first and highest peaks that are measured during a start comes from the fact that the chamber temperature is above 98°C. When the machine is stopped and the material is still within the chamber the temperature will come to equilibrium with its surroundings. The chamber temperature will be between 98 – 110°C when the machine starts and it would be expected to get one peak in the web temperature when the machine is started. This is however not the case, instead there are two peaks as can be seen in the previous figures, i.e. 5.9 and 5.10. In order to explain this phenomenon it was decided to measure the web speed so that the exact position of where, on the web, the peaks appear. The air temperature at the top middle and bottom of the chamber was measured as well.

5.3.1 Measurement equipment

A web speed measurement tool, RadioEnergie 91300-Massy-France, was installed on the machine. Thermocouple thread (type K) was mounted at three points in the chamber in order to measure the chamber temperature. It was installed so that the direct radiation from the elements would be minimized.

As before an analogue output card was installed on the PLC for measuring desired outputs.

The outputs from the PLC card and the web speed measurement was measured by an IOtech data shuttle and logged with a personal computer running Dasy Lab 6.0.

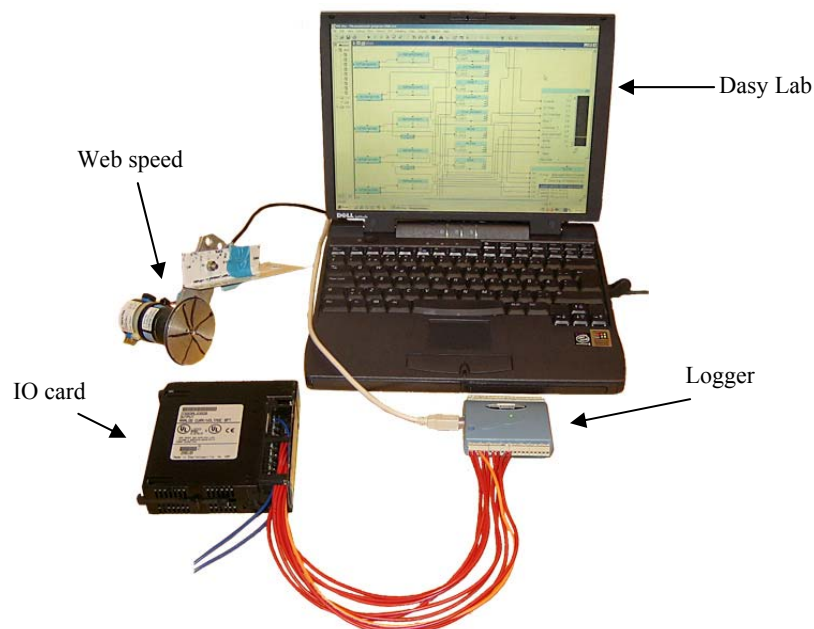

Figure 5.14

The measurement equipment used to collect data from the PLC as well as the web speed monitor.

5.3.2 Results

Figure 5.15 shows that, as concluded before, that the chamber has its maximum temperature at the bottom when the machine is stopped. The temperature difference between top and bottom was about 10°C. The temperature measured by the original probe was always higher than the new probes, this probably since the new probes were mounted closer to the chamber walls and the old probe is situated in the middle of the chamber, between the heating elements.

That the chamber temperature is higher at the bottom of the chamber probably originates from turbulence in the chamber.

When the machine is started the bottom temperature decreases because new, cold, material enters the chamber. The temperature increases after a while as the elements are heated.

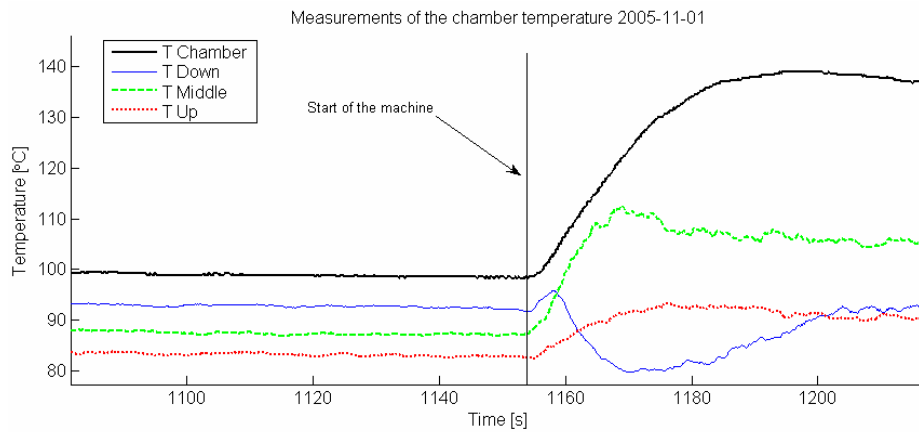

Figure 5.15
Shows the different temperatures in the chamber.

Figure 5.16 shows the result from the web speed measurement. In the figure the web speed has been integrated so that the position of the web has been extracted. Three vertical lines indicate where the bending rollers are situated seen from the chamber exit. The first line represents where the material from the roller at the bottom comes in contact with the measurement probe. The second line indicates the roller at the top of the chamber and the third line marks the chamber entrance, i.e. new material has passed the chamber.

The pattern in the figure repeats itself for every start of the machine. The two peaks appear at approximately the same place, at the top roller and the chambers entrance.

As the last figure suggested the chamber temperature is highest at the bottom of the chamber, this could explain the position of the peaks. The measurement probe has a limited rise time and therefore the expected peak that should have occurred at the first, lower, roller might very well be present.

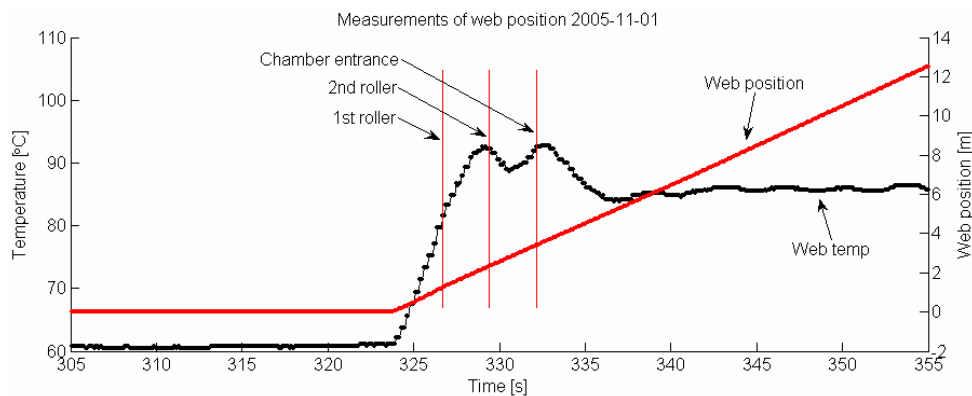

Figure 5.16
Web position measured during a start.

5.4 Step response identification

The first identification procedure used is step response identification, as described in section 4.1.1. To do this the PLC program was modified in order to create a step in the control signal to the system. This was done by enabling the manual function in the PID controller and setting a constant value to the output. This value was then changed in steps, up and down, and the process response was logged. The alarm limits had to be increased since they are too narrow in order to get a good signal to noise ratio.

This procedure was performed both when the machine was running and stopped in order to identify both systems.

5.4.1 Measurement equipment

The setup was exactly the same as in section 5.2.1.

5.4.2 Results

Figure 5.17 shows the result from the step response test performed on the machine when it was running. The top line in the figure shows how the web temperature acts when the input to the chamber elements was changed in a step as the bottom line in the figure indicates. As can be seen, especially in the cooling down flank, the process has a fast and a slow response. This shall not be compared to a stop of the machine as described in section 5.1.2 where the web was stopped. In this test the web was moving and the control signal to the elements was changed. The fast and the slow response are due to radiation and convexity phenomenon, convexity being the slowest. This since the web temperature is a result of the chamber temperature.

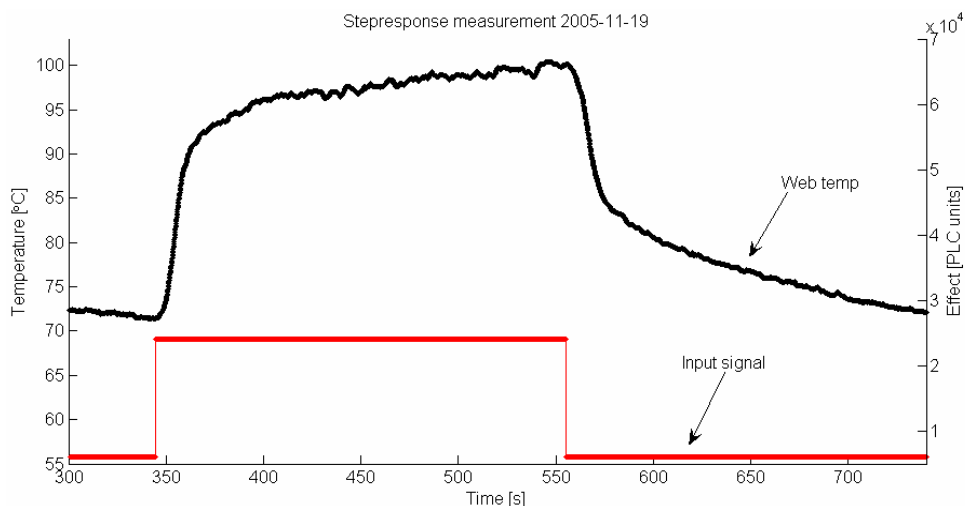

Figure 5.17

Step response on the web temperature performed whilst the material is moving.

Figure 5.18 shows the result from the step response test performed on the machine when it was in stop mode. The top line in the figure shows how the chamber temperature acted when the input to the chamber elements was changed in a step as the bottom line in the figure shows. The same fast and slow behaviour as seen in previous figure can be seen here.

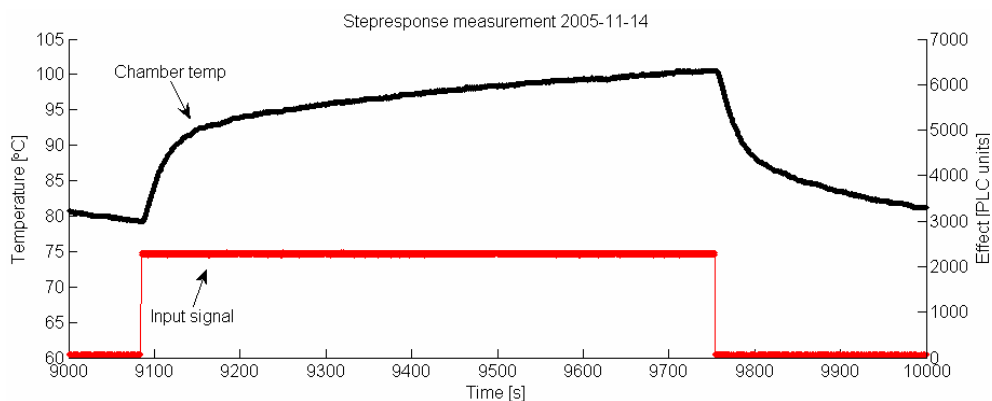

Figure 5.18

Step response on the chamber temperature when the material is stopped.

5.5 Frequency response measurements

To further deepen the understanding of the system a frequency response test was performed. Frequency response testing is described in section 4.1.2.

The PLC was modified so that the input to the process was a sine wave with different frequencies. With the machine running and in stop mode the outputs from the process (temperatures) were logged. A sine function in the PLC generated a signal with different frequencies that was sent to the PID controllers manual output. This enabled open loop identification.

5.5.1 Measurement equipment

The setup was exactly the same as in section 5.2.1.

5.5.2 Result

Figure 5.19 shows the frequency response of the web temperature when the machine was running. The top signal is the web temperature adjusted so that the mean value is zero and any linear trends removed. The bottom signal is the input signal to the elements.

As can be seen the amplitude of the web temperature decreased with increasing frequency as can be seen in figure 5.19. The phase shift is also noticeable for higher frequencies, this shown in figure 5.20 which displays a zoomed plot of the higher frequencies. Bode diagrams are presented in section 6.2.

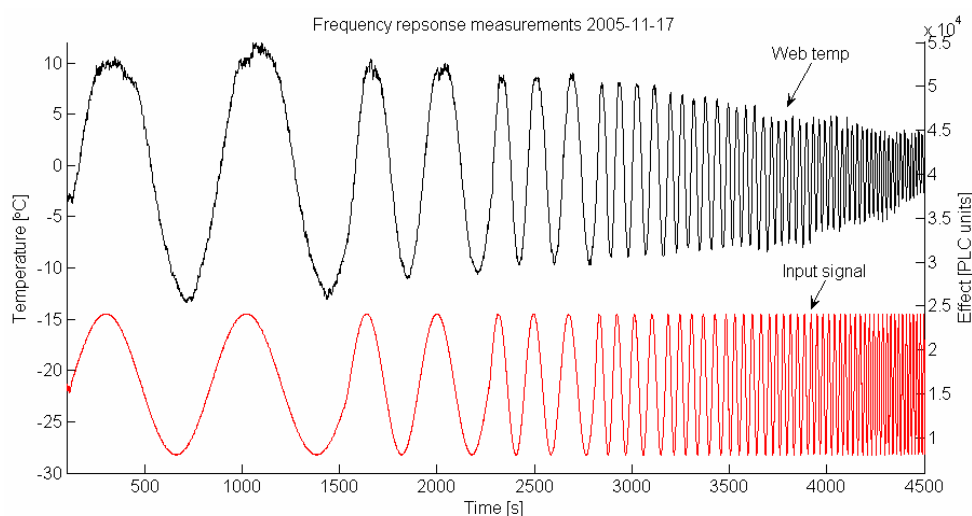

Figure 5.19

The web temperature gain depends on the frequency as seen in the figure.

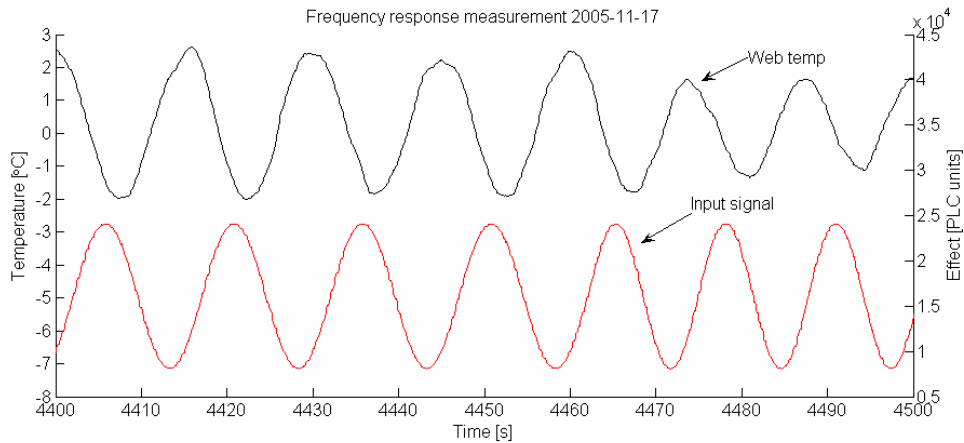

Figure 5.20
Zoom of the higher frequencies from figure 5.19

Figure 5.21 shows how the chamber temperature reacted when the machine was stopped. As in the previous figure the data is processed so that the mean value of the signal is zero and linear trends removed. The amplitude decrease and the phase shift appear in this signal as well.

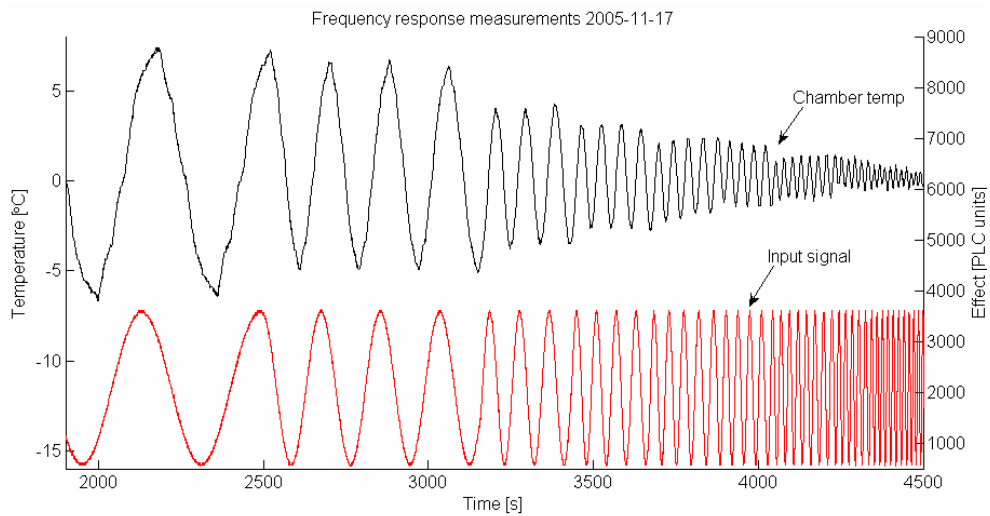

Figure 5.21
The chamber temperature gain depends on the frequency as seen in the figure.

6. Modelling and simulation

6.1 Creating a process model

From the measurements process models can be generated and the control of the process can be evaluated. In this chapter two different identification methods will be used and compared in order to produce two process models.

The reason for generating two models is that the feedback to the control of the elements is from different measurements probes when the machine is running and stopped. The web temperature probe is used for controlling the web temperature to 84°C when the machine is running and the chamber temperature probe is used to control the chamber temperature to 98°C when the machine is stopped.

6.1.1 Step response identification

From the experiments shown in figure 5.17 and figure 5.18 the dead time, the time constant and gain of the process were estimated using the technique described in chapter 4.1.1. This gives:

Web temperature	Chamber temperature
$K = 0.014$ [PLC units / °C] $t_C = 10.0$ [s] $t_D = 4.3$ [s]	$K = 0.055$ [PLC units / °C] $t_C = 26.8$ [s] $t_D = 3.3$ [s]
Process model: $G(s) = K \frac{e^{-t_D s}}{1+t_C s} = 0.014 \frac{e^{-4.3s}}{1+10s}$	Process model: $G(s) = K \frac{e^{-t_D s}}{1+t_C s} = 0.055 \frac{e^{-3.3s}}{1+26.8s}$

Table 6.1

Now two, first order, process models are derived. The models simulate how the temperature in the chamber and on the web will respond to different inputs. In the PLC the temperature measured is the actual temperature times ten, so 98,1 degrees in the chamber corresponds to 981 units in the PLC. Using this temperature the PID implemented in the PLC calculates a control value between 0-32000 units. Tuning of the PID will be described in later chapters.

Below, in figure 6.1, the step response from the model versus the real process is shown for the web temperature. It can be seen that the fast response, the first flank, is modelled quite good but the slow increments after this flank is missed by the model. To conclude, it is of greater importance that the model is accurate for the fast response than for the slow. This since any slow drifting of the controlled variable will be suppressed by the control, which is designed to handle fast deviations.

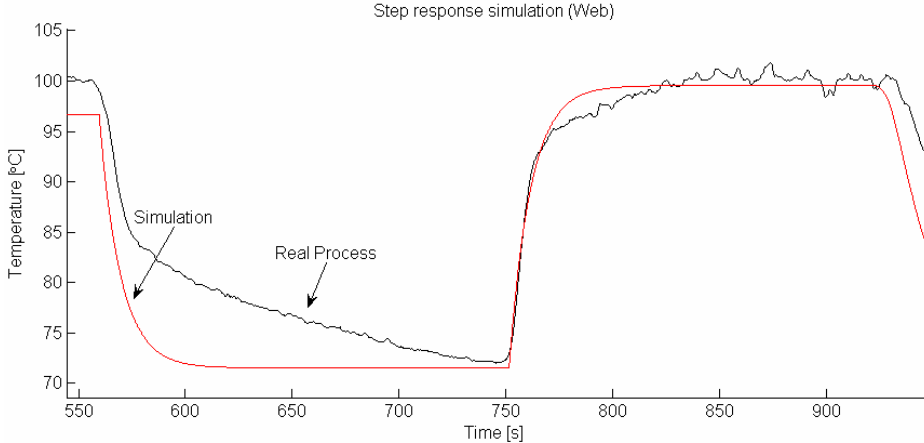

Figure 6.1
The step response of the first order model of the web compared to the real process.

Figure 6.2 shows the step response for the chamber temperature compared to the designed first order model. This model, as well as the previous, also models the fast temperature variations with acceptable accuracy. In the next section the models will be improved to also handle the slow temperature variations.

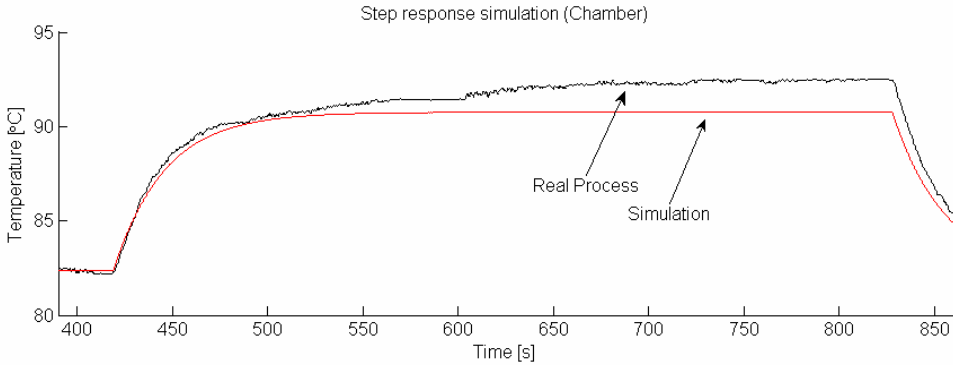

Figure 6.2
The step response of the first order model of the chamber compared to the real process.

6.1.2 Frequency response

In order to improve the models the frequency response tests are used to create better models. The modelling was done using System Identification Toolbox Version 6.1. This program builds a mathematical model of the system by adjusting parameters within a given model until the models output coincides as well as possible with the measured output.

The characteristics of the step response appears to be the sum of two first order systems, one fast and one slow, with a time delay. The sum of two first order systems can be written as a second order system with a zero as shown below:

$$\left(\frac{K_1}{1+t_{C_1} \cdot s} + \frac{K_2}{1+t_{C_2} \cdot s} \right) \cdot e^{-t_d \cdot s} = \dots = (K_1 + K_2) \cdot \frac{1 + \frac{K_1 \cdot t_{C_2} + K_2 \cdot t_{C_1}}{K_1 + K_2} \cdot s}{(1+t_{C_1} \cdot s) \cdot (1+t_{C_2} \cdot s)} \cdot e^{-t_d \cdot s} =$$

$$K \frac{1+t_Z \cdot s}{(1+t_{C_1} \cdot s) \cdot (1+t_{C_2} \cdot s)} \cdot e^{-t_d \cdot s} \quad \text{Equation 6.1}$$

This model was selected for System Identification Toolbox to use for parameter estimation. The identification was performed on the data shown in figures 5.19 and 5.21. The output data was multiplied with ten in order to be consistent with the data used by the PLC. Note that linear trends and non zero mean is removed.

Here follows a presentation of the result from the identification.

Web temperature	Chamber temperature
<p>K = 0.021608 [PLC units / °C] $t_{C_1} = 156.96$ [s] $t_{C_2} = 6.447$ [s] $t_Z = 81.527$ [s] $t_D = 5.2897$ [s]</p> <p>Process model: $G(s) = \frac{0.022 \cdot (1 + 81.53 \cdot s)}{(1 + 156.96 \cdot s) \cdot (1 + 6.45 \cdot s)} \cdot e^{-5.30 \cdot s}$</p>	<p>K = 0.062776 [PLC units / °C] $t_{C_1} = 113.73$ [s] $t_{C_2} = 19.918$ [s] $t_Z = 75.817$ [s] $t_D = 3.5567$ [s]</p> <p>Process model: $G(s) = \frac{0.063 \cdot (1 + 75.82 \cdot s)}{(1 + 113.73 \cdot s) \cdot (1 + 19.92 \cdot s)} \cdot e^{-3.56 \cdot s}$</p>

Table 6.2

The same step response is now performed on this, improved, model. Figure 6.3 shows that this model estimates both the fast and the slow dynamics of the process much better as compared to the first order model.

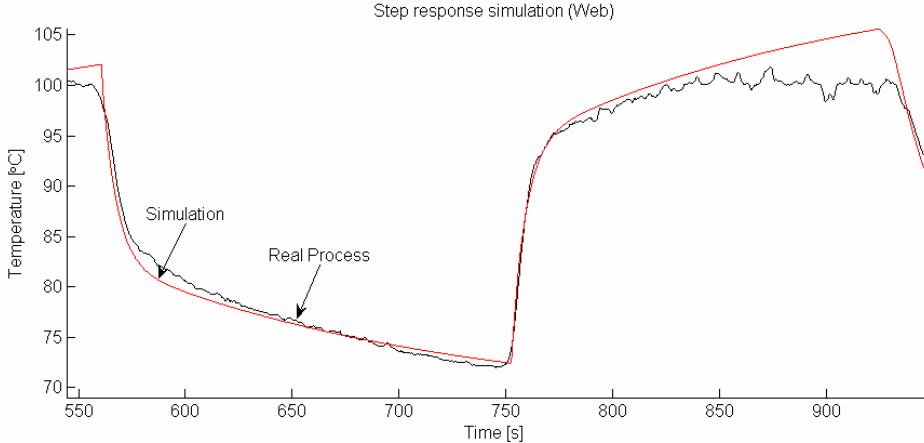

Figure 6.3
The step response for the second order model of the web compared to the real process.

The chamber temperature model is also improved to predict the slow drift in the temperature which can be seen in figure 6.4.

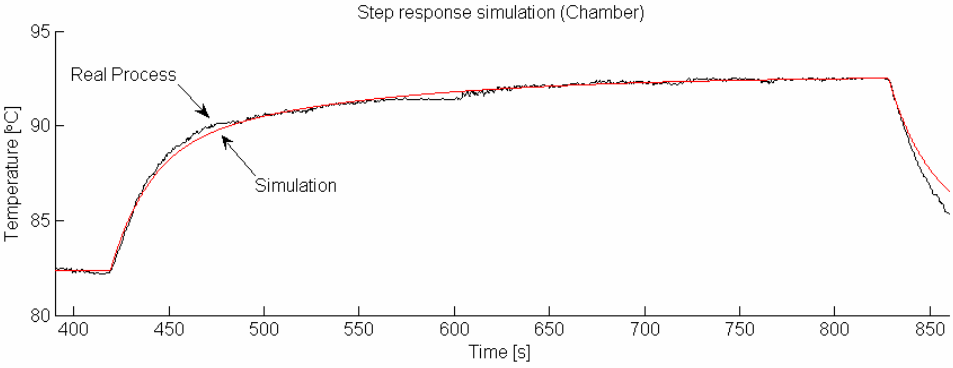

Figure 6.4
The step response for the second order model of the chamber compared to the real process.

6.2 Bode diagram

Another way to verify the accuracy of the model is to compare the bode diagram from the model with the bode diagram obtained from the frequency response test. The calculations of the bode diagram from the frequency response test are described in section 4.1.2.

In figure 6.5 the bode diagrams for the first and second order models are compared to the bode plot attained by the above calculations.

As seen in the figure the second order model simulates both the gain and the phase shift more accurately than the first order model.

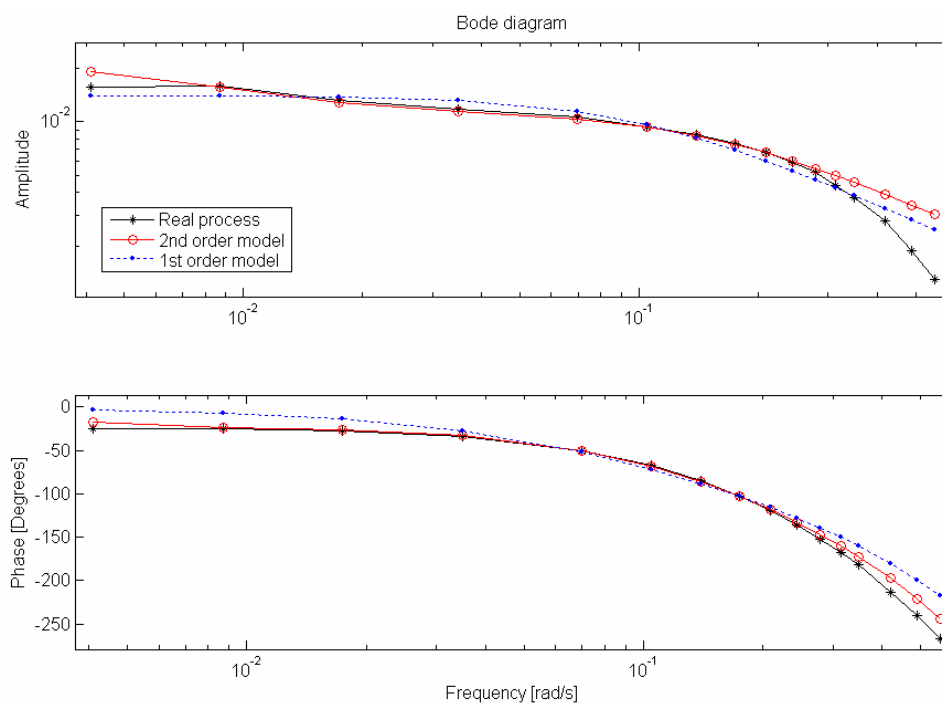

Figure 6.5

The web temperature bode plot for the first and second order models compared to the real process

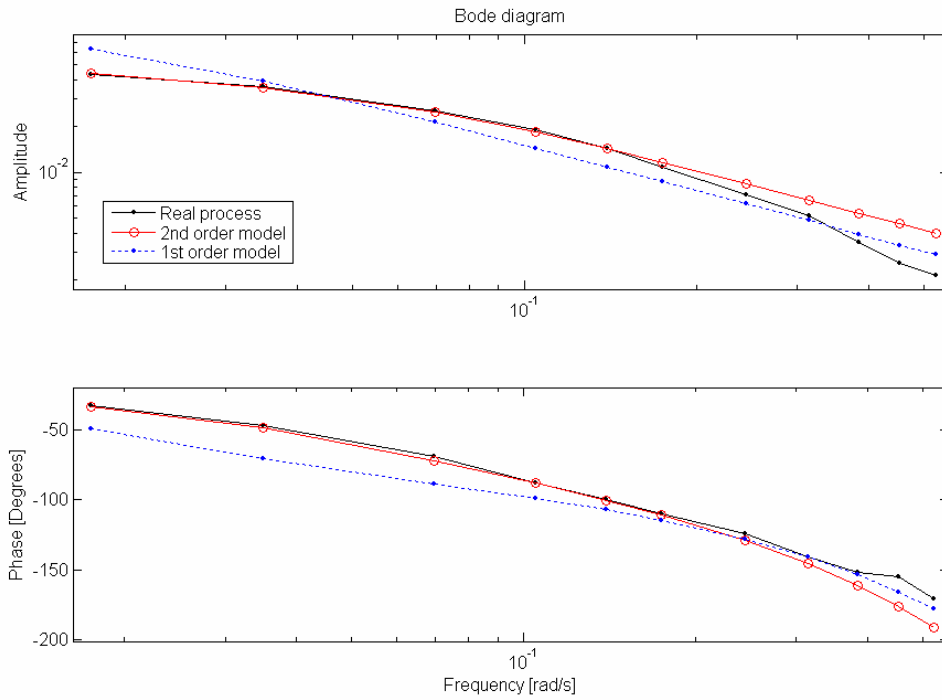

Figure 6.6
The chamber temperature bode plot for the first and second order models compared to the real process

6.3 Simulink model

With the help of Matlab and Simulink it is now possible to simulate different control strategies of the system. In Simulink it is possible to both import real data and create different reference signals and then run the simulation in order to study the response from the model. This is what was done to compare the step response of the model with the real step response. This will be demonstrated in the following chapter.

7. Designing a new control

To guarantee a certain degree of sterilization and minimum peroxide residue, constraints on the web temperature are set at $\pm 3^\circ\text{C}$. This means that if the web temperature deviates from the desired temperature of 84°C by more than 3°C , under normal production (90s after a start), the machine will halt. During the initial peaks (caused by the chamber temperature) and the following pre-programmed sequence, the upper limit is set to 110°C ($84^\circ\text{C} + 26^\circ\text{C}$). It is therefore crucial that the new control manages these alarm limits and minimizes the time after start up that the temperature deviates from the set point. The original set up sometimes causes the machine to stop when the alarm limits are shifted from 26°C to 3°C above the set point.

The different stages of control design are divided into three sub chapters.

7.1 Choice of PID structure

The optimal implementation of a controller for a system constituting of two poles, a zero and a time delay, where one pole is fast and the other slow, is a controller with at least two degrees of freedom. The GE Fanuc PLC used is not supporting this control structure therefore the control will be implemented with PID controllers. One drawback of this is that it is impossible to totally avoid overshoots when the set point is changed. The set point for the controller will only be changed one time during each production loop and therefore the effects of this implementation will be small.

The PLC system currently used in the Tetra Pak A1 machine has two different implementations of a PID controller, the standard (ISA) and the independent (IND). Equation 7.1 shows the difference between the two forms. The P, I and D terms represent the values fed to the PLC.

$$u(t)_{ISA} = K_C \left(e + \frac{1}{T_i} \int e(t) dt + T_d \frac{de}{dt} \right) = P \cdot \left(e + I \int e \cdot dt + D \frac{de}{dt} \right) \quad \text{Equation 7.1}$$

$$u(t)_{IND} = K_C \cdot e + \frac{K_C}{T_i} \cdot \int e(t) dt + K_C \cdot T_d \frac{de}{dt} = P \cdot e + I \int e \cdot dt + D \frac{de}{dt}$$

Figure 7.1 on the next page shows a graphical representation of the mathematical expression for ISA and IND controllers implemented in the GE Fanuc PLC system.

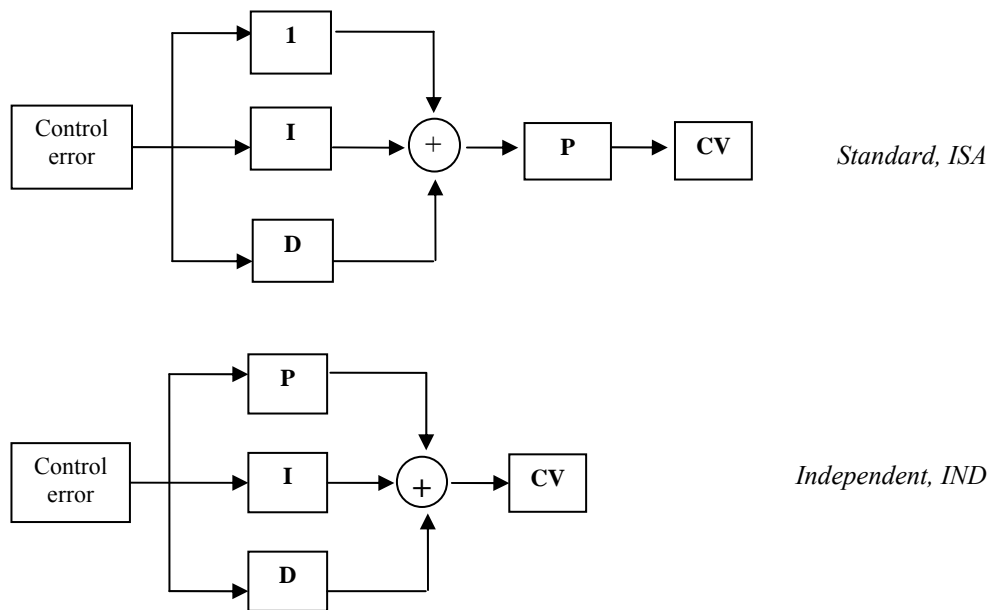

Figure 7.1
 Both the standard and the independent form of controller are implemented in the GE-Fanuc. They are called the ISA and the IND type PID.

7.2 PID tuning

Using the lambda tuning scheme and the Ziegler-Nichols method from section 4.2, the PI-control parameters were calculated from the first order models of the processes identified in section 6.1.1. For the lambda scheme the lambda factor, κ , was set to 1 to receive a relative neutral controller (neither to aggressive nor to slow). The values attained from section 4.2 are represented in the independent, IND, form.

Web	Chamber
Original setting $P_{\text{Orig}} = 90$ $I_{\text{Orig}} = 5$ $D_{\text{Orig}} = 0,01$	Original setting $P_{\text{Orig}} = 60$ $I_{\text{Orig}} = 2,4$ $D_{\text{Orig}} = 0$
Lambda scheme $P_{\lambda} = 50$ $I_{\lambda} = 5$	Lambda scheme $P_{\lambda} = 16,2$ $I_{\lambda} = 0,6$
Ziegler Nichols $P_{\text{ZN}} = 149,5$ $I_{\text{ZN}} = 11,6$	Ziegler Nichols $P_{\text{ZN}} = 132,9$ $I_{\text{ZN}} = 13,42$

Table 7.1
 The controllers parameters represented in the independent form, IND.

Since the web temperature signal contains some signal noise the derivative part of the controller must be kept at a low value, otherwise the control value will be very noisy. Filtering the signal is a possible way of lowering the noise but this introduces further delay on the system. This is why a simple PI-controller was implemented. It gave fast enough response time and kept the overshoot at a minimum.

7.2.2 Simulation

By implementing the identified system in Matlab Simulink, different control strategies were tested and compared. Both PI and PID controllers were tested for varying degrees of aggressiveness. The Simulink implementation of the PID-controller and system is seen in figure 7.2.

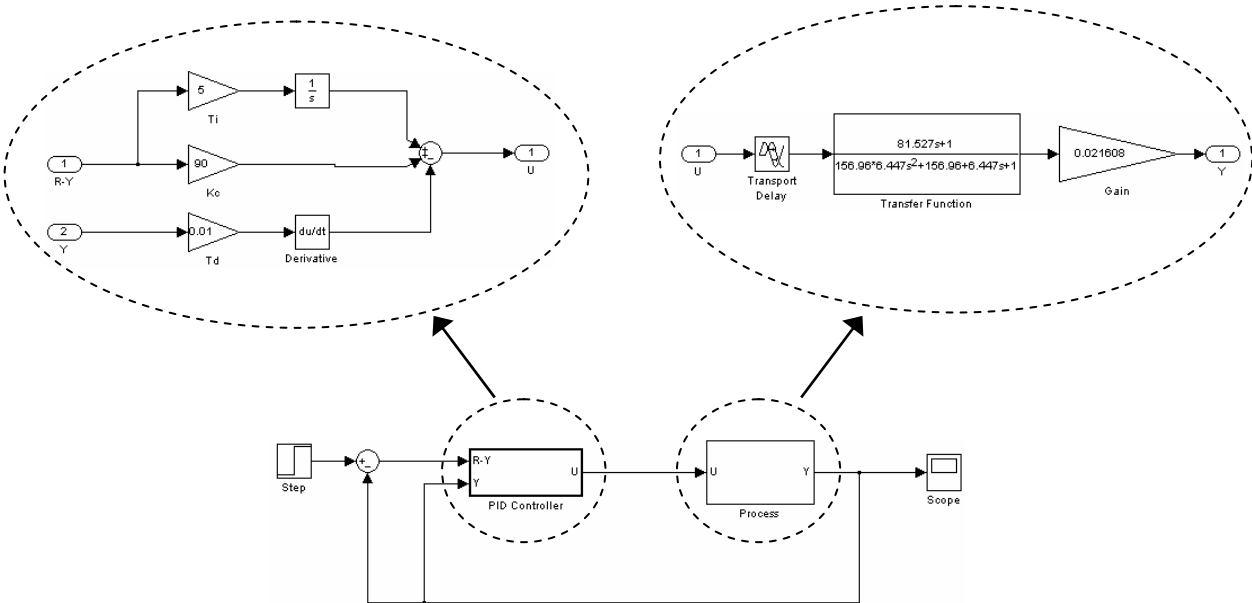

Figure 7.2
Simulink implementation of the closed loop system.

To validate the models and the simulation the simulated web temperature controller was implemented with the same parameters as the original controller working in the machine. A step response test was performed in the simulation and this was compared with a step response test from the actual process. In figure 7.3 the results are displayed, the two plots to the left show the results from the simulation and the plots to the right display the real process. The simulation shows the same characteristics as the real process, both in the temperature and in the control signal.

When the step is performed the control signal makes a step due to the gain, P, part of the PI controller. During the following dead time, before the process responds, the I part integrates the error and therefore the control signal increases until the temperature responds. The following changes are due to the interaction between the P and I parts and at last the temperature settles.

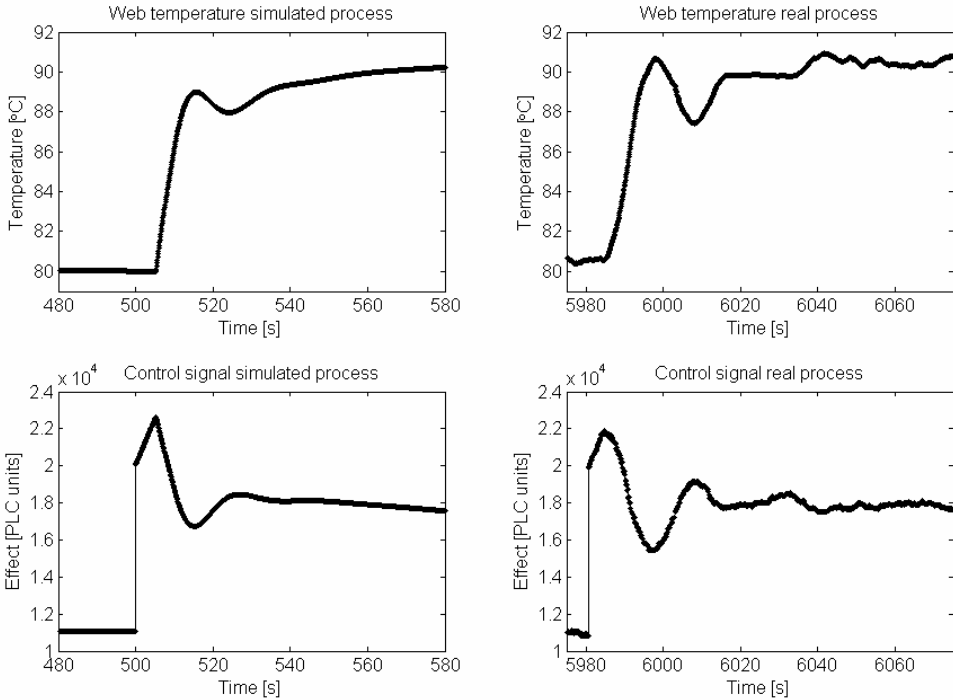

Figure 7.3
Comparison between the real and the simulated process with the original PID parameters.

With the help of Simulink and the derived models different settings of the controllers were tested until desired characteristics of the closed loop system were achieved. Table 7.2 presents the final choices of parameters for the PI controller that will be tested on the real process.

Web	Chamber
$P_{Sim} = 60$ $I_{Sim} = 7.5$	$P_{Sim} = 40$ $I_{Sim} = 1$

Table 7.2

The different controllers were tested by simulation of the closed loop system. In figure 7.4 the resulting plots from changes in the set point for the web temperature are displayed. Here it can be seen that using the Ziegler Nichols tuning approach tends to generate a too aggressive control. The lambda tuning scheme also provided an aggressive controller that causes the web temperature to shoot over its desired set point.

The resulting step from the controller derived with the help of simulation is also displayed, it is less aggressive than the two controllers attained from calculations but still more aggressive than the existing one resulting in a fast step without significant overshoots.

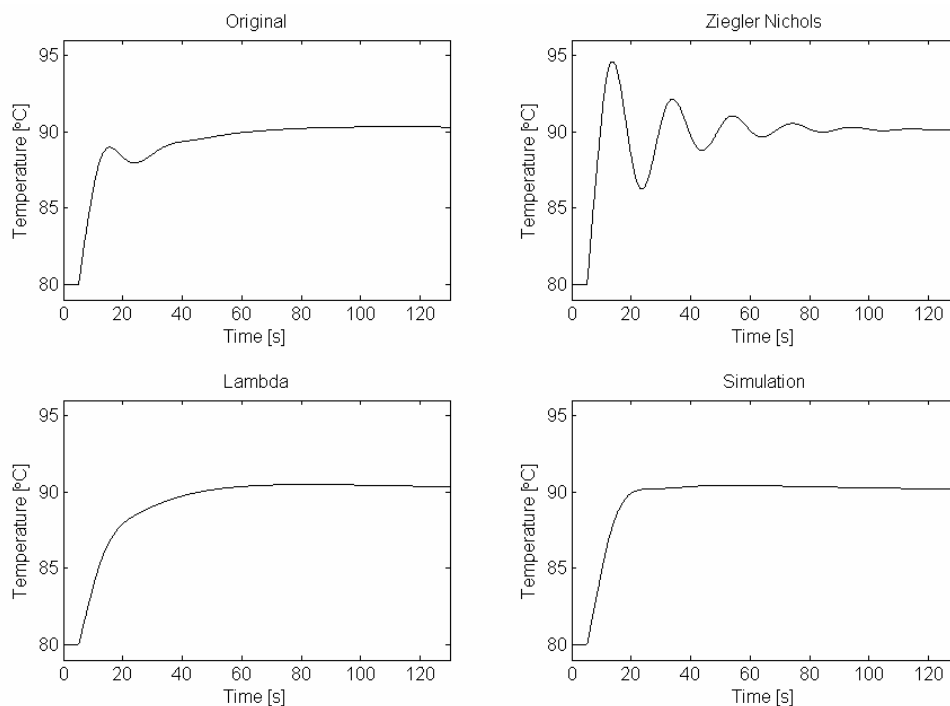

Figure 7.4

Step responses for the web simulated with the PID parameters as expressed in table 7.1 and 7.2.

In figure 7.5 the parameters for the chamber are tested. The original set up was already tuned in a good way with fast and accurate response. With the simulations new parameters was derived that will result in a slightly slower closed loop system. This to see if the slower parameters would remove some of the small oscillations that occurred during tests with the original settings.

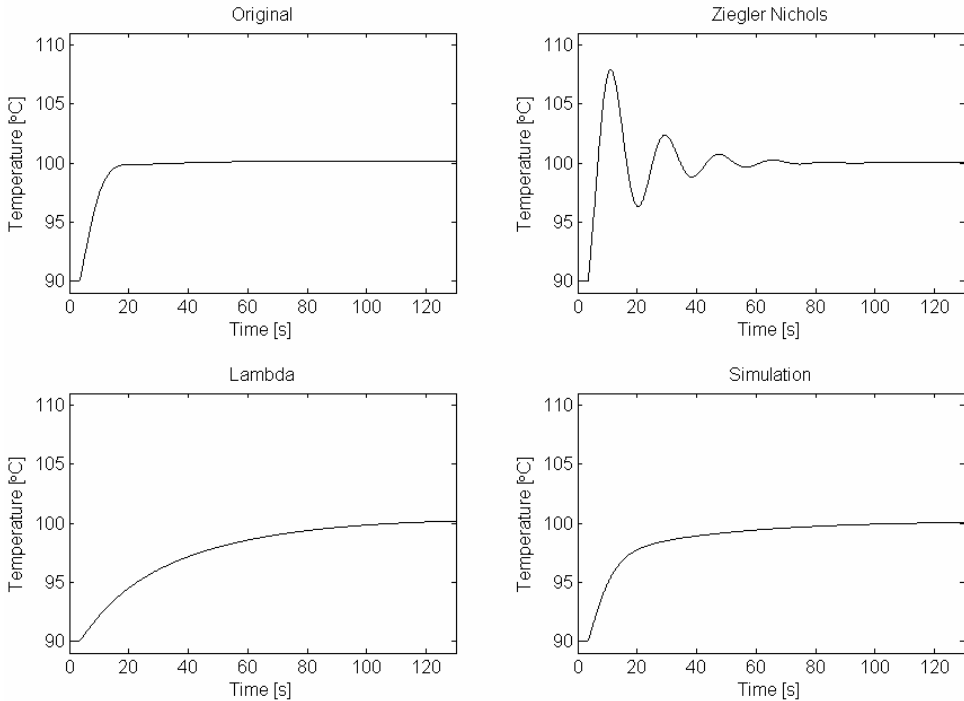

Figure 7.5
Step responses for the chamber simulated with the PID parameters as expressed in table 7.1 and 7.2.

To test the system's robustness a disturbance test was simulated. The disturbance can be seen as if the old material roll has been spliced with a new cooler one. For example if the material storage facilities have a different temperature than where the machine is kept. Figure 7.6 displays a step disturbance in the material surface of 8.5°C starting from $t=700\text{s}$. As seen in the figure, the temperature dip due to the cold material just reaches the lower alarm limit of 81°C . This means that the alarm limits can not be held if the temperature difference exceeds 8.5°C as the material enters the chamber. Since the material travels a couple of seconds before reaching the chamber the actual temperature difference between the new roll and the old can be larger.

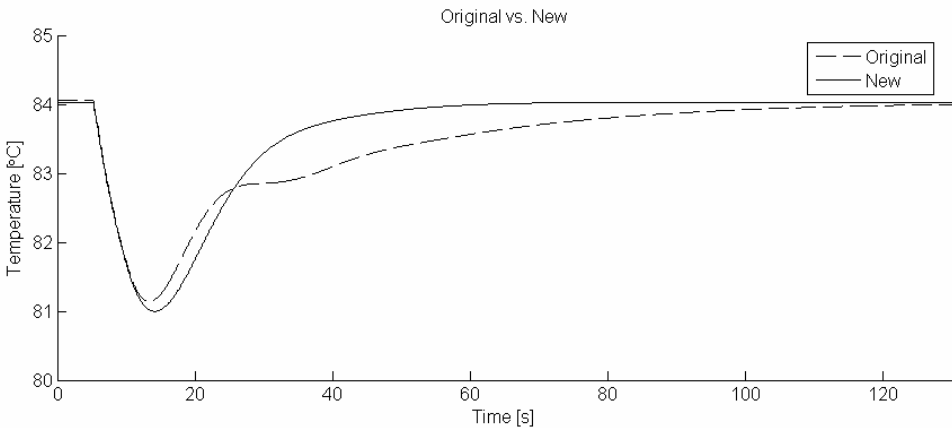

Figure 7.6
Disturbance test of the old and new control in closed loop.

7.3 Start up control

To minimize the amount of discarded packages from a production halt it is essential that the web temperature reaches its set point as fast as possible. Since the starting temperature for the chamber may vary, depending on the length of the stop, and the fact that for the first couple of seconds the web temperature measurements are not dependable, as discussed earlier. Therefore it was decided to control the first couple of seconds with open loop control. This means that the web temperature has no impact on the control signal during this period. In order to adapt the control signal to the current conditions in the chamber the chamber temperature will be used to calculate a start value of the control signal. This value will be used for the first couple of seconds, until the measured value from the web temperature measurement is dependable. To calculate the start control value a series of tests were conducted on the machine. Samples of these tests are shown in figure 7.7. A series of starts, at specific chamber temperatures were conducted and a linear function adapted to the result. This is seen in figure 7.8.

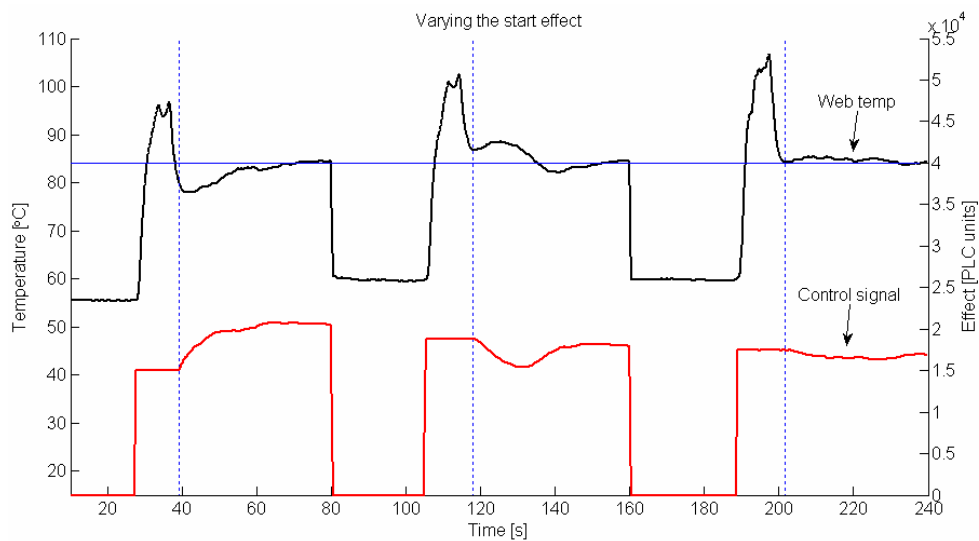

Figure 7.7
To low, to high and perfect start values.

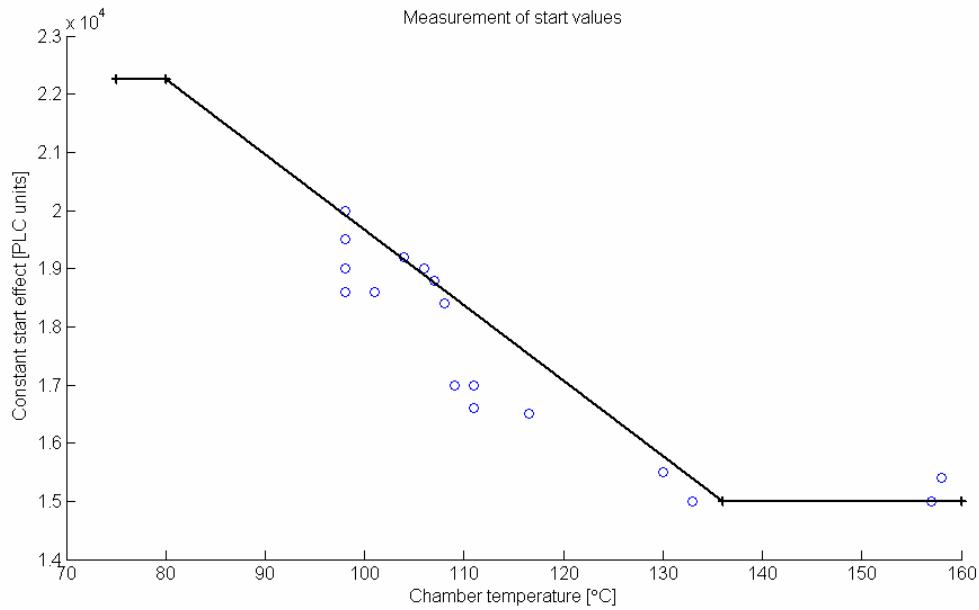

Figure 7.8

Showing the adapted function $f(T_{chamber})$ to a number of starting values. Every circle marks a successful start, i.e. the web temperature is 84°C after the initial peaks.

The function adapted to the test results allowed the starting control value to be adjusted so that the finishing web temperature reached the desired level. The function calculates the starting value using the temperature as represented in the PLC (98°C=980). The function attained was:

$$\begin{cases} f(T_{chamber}) = 22250 & T_{chamber} \leq 800 \\ f(T_{chamber}) = 22250 - 13 \cdot (T_{chamber} - 800) & 800 < T_{chamber} < 1360 \\ f(T_{chamber}) = 15000 & T_{chamber} \geq 1360 \end{cases}$$

Equation 7.2

This function will generate a start value that guarantees the web temperature to be above 84°C after the initial peaks. This will meet the demands on residue levels of hydrogen peroxide. The temperature should rather be a bit high than too low, explaining the chosen function.

Since it takes 13 seconds until the web temperature measurements are dependable it is not wise to feed this signal to the controller. Therefore the control is kept in 'manual' mode, thus updating its internal parameters so that its output is matched to the start function, this allows the switching between the open and closed loop control to be performed bumpless. After this, the controller is set in auto mode removing any remaining deviations. Since the starting value is adapted to chamber temperatures, any constraints on when the machine can be started are removed, meaning that the stop time is not dependent on the chamber temperature at all. The original set up did not allow the machine to be started unless the chamber temperature was below 110°C which sometimes took up to 5 minutes.

7.4 Stop control

The problem with blisters during stops is due to the high working temperature of the chamber under production. When the machine is stopped the heating chamber needs to be cooled down fast to avoid these blisters. The energy transport out from the chamber is too small for the sufficient temperature decrease and blisters appear. One way to avoid this problem is to decrease the machine speed gradually whilst keeping the web temperature at 84°C. This will result in a cooler chamber temperature since the amount of time the material spends inside the chamber is longer. Due to the wish of instant stop of the machine when pressing the stop button this theory is discarded.

When the machine is stopped the chamber temperature will always be way above the desired set point of 98°C and therefore the output from the controller should be zero if no derivative part is used. This, however, is not always the case for the implemented controller. From measurements it was discovered that the controller sometimes generates an output signal different from zero during these stop conditions. This behaviour can be seen in figure 7.9. The stop PID-controller is enabled at $t \approx 880$ s and all internal states in the controller should be zero since the controller is switched off during the production phase. As seen in the figure the initial output from the controller is zero, but then rises, peaks and sinks back to zero during the cool down of the chamber. This is not at all motivated from the prevailing conditions since no derivative part is implemented in the controller. Therefore the conclusion is drawn that this is some sort of program error in the control algorithm.

A way to solve this problem is to manually set the controller output to zero whilst the chamber temperature is above the set point. This will get the desired behaviour during the cool down phase but will affect the control during steady state. If the control signal is manually set to zero as long as the temperature is above 105°C the strange behaviour could be avoided and the control will work as intended during steady state.

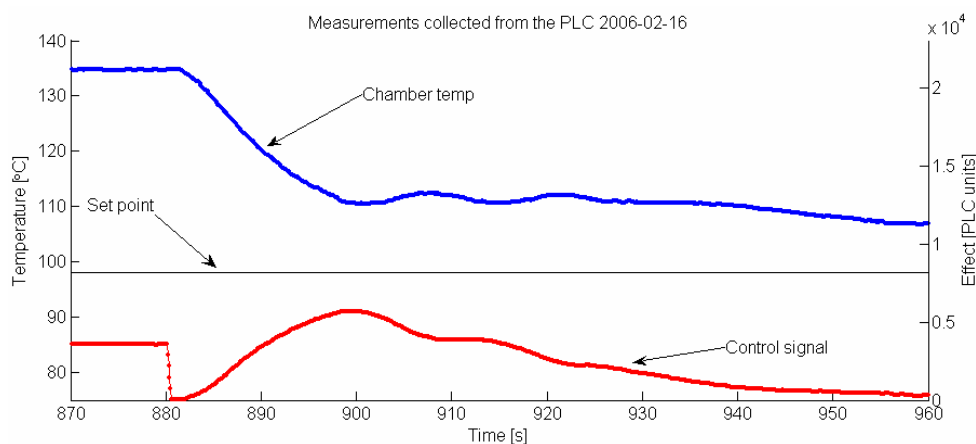

Figure 7.9

The control signal behaves irrational when controlling the chamber temperature to its set point.

8. Implementation

The current PLC system operating the A1 machine is built on the GE Fanuc Series 90-30. Program logics and configurations are all implemented using the LogicMaster 90 TCP/IP software. This software has predefined controllers. These are standard and independent PID's as discussed in section 7.1. Therefore the PID-theory explained in chapter 4.2 must be altered to fit the chosen type, as explained in equation 7.1. ^[R.3]

The current control logic uses both the IND and the ISA controller. There is however no practical reason for mixing the two, on the contrary, this might lead to confusion when tuning. For simplicity one controller form was selected, the choice fell upon the independent type PID because it has a simple and logical implementation. Increasing the proportional part will not affect the integral part as in the standard form. In the PID configuration it is also possible to set a number of parameters such as: sample period, dead band, bias, upper and lower clamp and minimum slew time. Further configuration includes normal or reversing error term, positive or negative output polarity, derivative action on the process value or the error term and anti-reset windup. These settings must be initiated, as well as the PID-settings, on the first computational scan of the CPU. Otherwise old values may still be occupying the memory variables. The control value outputted from the PID is in the range of 0-32000. The on-off signal explained in section 3.3.1 is still used but any settings apply to the 0-32000 range. The following settings were implemented for the web temperature and chamber controller:

	Web	Chamber
P-gain	60	60
I-gain	7.5	2.4
D-gain	0	0
Sample time	0 s	0 s
Dead band [+ -]	[0 0]	[0 0]
Bias	0	0
Clamp [upper lower]	[27000 0]	[6000 0]
Minimum slew time	0	0
Output polarity	Positive	Positive
Derivative action	PV	PV
Anti-reset windup	On	On

Table 8.1

The P, I and D-gains were calculated, as explained in the previous chapter, and fine tuned through machine tests. For the web the simulated parameters were found to be a good choice. Through testing it was decided to keep the original parameters for the chamber. The sample time was set to zero, meaning that the algorithm is executed on every PLC-sweep,

thus setting the actual sample time to 30 ms. The only benefit of a longer sample time would be to reduce the CPU load. Since the energy transportation means are purely electrical (heat is transported through resistive elements), no consideration for mechanical wear has to be taken and therefore minimum slew time is set to zero. The load on the CPU is of no concern so the dead band was removed, having a dead band would just introduce a nonlinear part to the system. No bias term is needed so it could be set to zero. To ensure that the web would not catch on fire the control signal was limited to 27000 when running and 6000 when stopped. Transferring more heat than at 27000 will make the plastic film on the paper soft, causing it to stick to the temperature measuring device leading to inaccurate measuring. The lower clamp is obvious, since a negative control value will result in a negative current through the heating elements and this will give a positive energy release. A positive output polarity will calculate the error term as set point minus process value (SP-PV), as described in the standard form in chapter 4.2. Derivative action can either be calculated on the error term or the PV. If calculated on the error term a step in the set point will generate a large derivative term, because of the discontinuity in the error term. The anti-reset windup will update the internal calculations for the control signal when the output is clamped. This will ensure that the control value will be held at the clamped value until the sum of the P,I and D-parts are less than the clamped value.

Calculation of the start algorithm was done using ints (16-bit integer). This is why the function has its zero at 80°C instead of 0°C. Using 0°C as zero would force the calculation to be done by reals (32-bit real) which would increase the computational time and complexity of the implementation. To further cut down on computational efforts, the controller (chamber or web) is turned off whilst the other is operating. Giving the total control logic, so that while the machine is in production halt, the chamber controller keeps the temperature at the desired set point and the web controller is turned off. When the operator pushes the start button the starting value is calculated from the chamber temperature (as described above). The chamber controller is turned off and the web controller is tuned on but put in manual mode with the output set to the calculated start value. After 13 seconds of manual control value the controller is set to auto and any deviations from the set point are removed by the controller. When the operator or any machine alarms cause the machine to stop the web controller is switched off and the chamber controller is turned on again. Thus concluding the control logic for a production run.

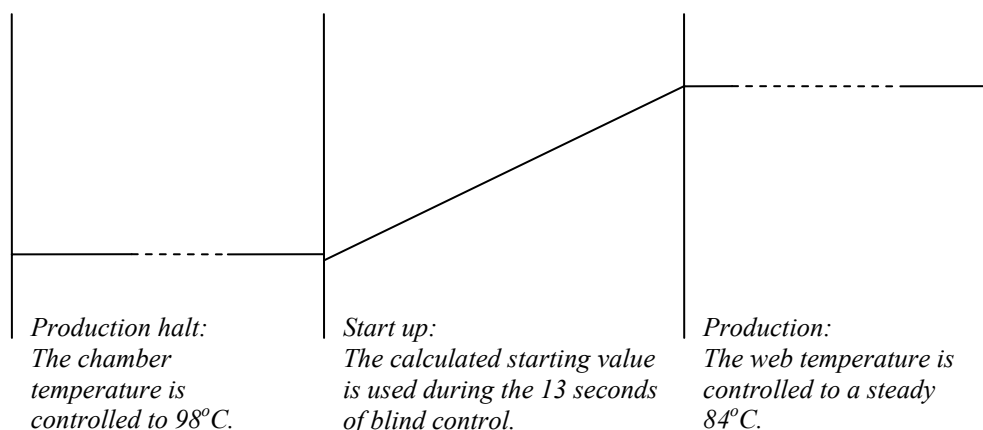

Figure 8.1
Schematics of a production run.

9. Validation

Validation was performed on two nearly identical machines. This way the controls robustness against small variations such as probe placements and chamber variation could be tested. The control should handle small variations in chamber configuration since the air flow inside the chamber seems to be very turbulent and non deterministic. Since the chamber temperature probe is very sensitive to radiation the slightest nudge from its position might alter its readings. This is not a major problem since the probe is not used as feedback during production and that the energy emitted through radiation is much less during production halt.

9.1 Validation of simulation

To test the attained parameters from the simulated tuning process step response tests were conducted on the closed loop system with the derived PI-parameters. As can be seen when comparing figure 9.1 with figure 7.4 the behaviour is as expected, the models and simulations for the web is adequate. Comparing figure 9.2 with figure 7.5 shows that all responses, except Ziegler Nicholds, are as expected. That Ziegler Nicholds does not match the simulation can be explained by the fact that the control signal is clamped.

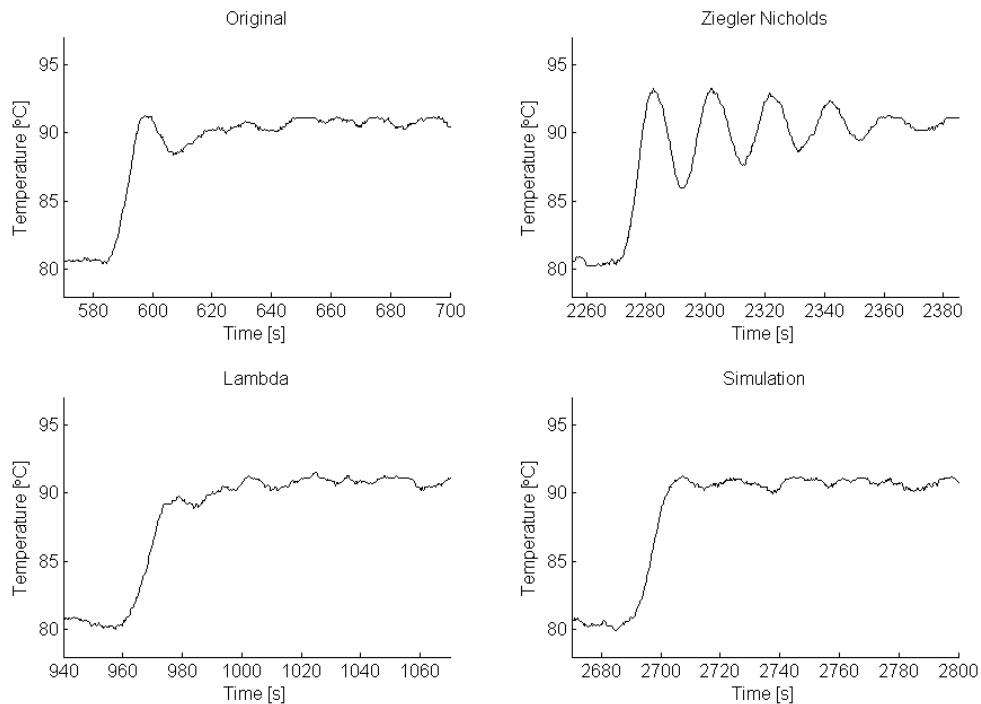

Figure 9.1
Step response for the web conducted from the real process.

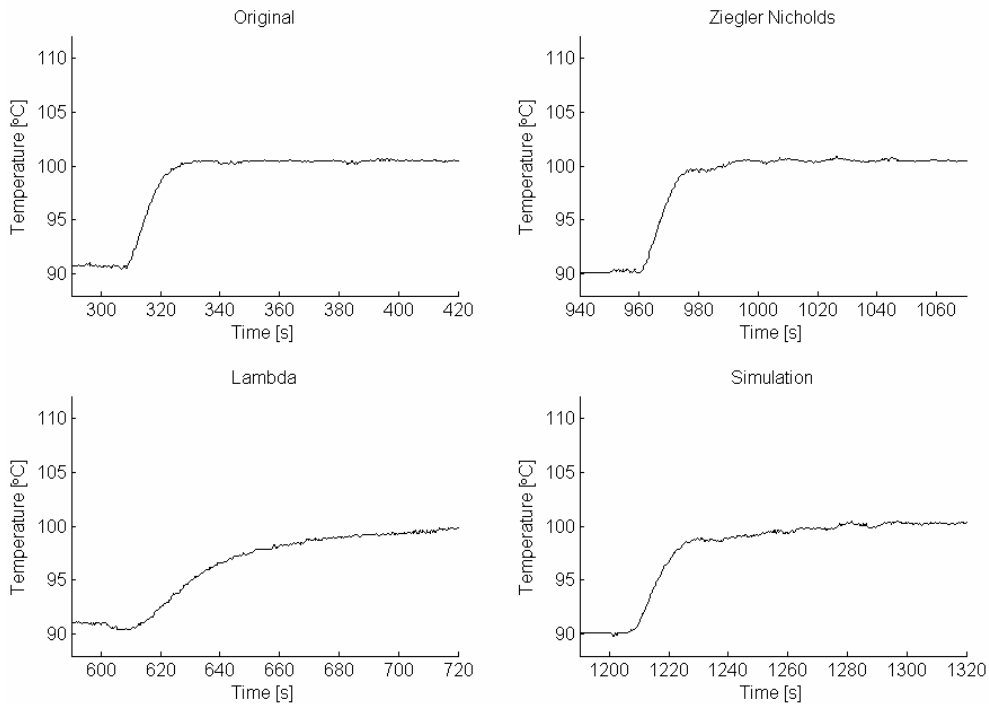

Figure 9.2
Step response for the chamber conducted from the real process.

9.2 Validation of start function

To validate the newly derived control strategy a series of starts at different conditions was performed. Below in figures 9.3 – 9.6 the machine was started at different chamber temperatures.

Figure 9.3 shows the most common start, the one where the chamber temperature is at its set point 98°C. As seen in the figure the web temperature is just above the 84°C set point when the initial peaks have passed. The following overshoot is due to the inertia of the system i.e. the chamber is heating up. The control signal shows that the initial 13 seconds need much more effect to heat up the chamber than the following static control that holds the desired set point.

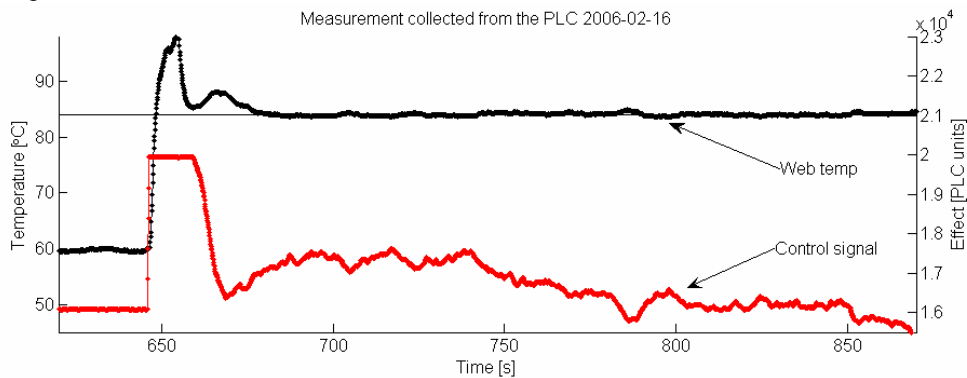

Figure 9.3
Test of new control during a start with the chamber temperature at 98°C.

Figure 9.4 shows a start where the machine is stopped and then started as soon as possible with the old 110°C limitation on the chamber temperature. The chamber is now hotter which will reduce the inertia of the system, thus lowering the overshoot after the initial 13 seconds. The value of the control signal is now lower than in the previous figure, yet leaving the web temperature just above 84°C, validating the accuracy of the start function.

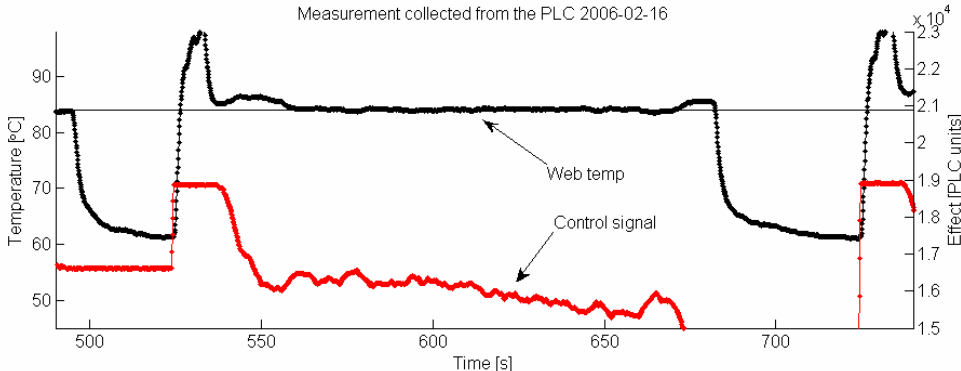

Figure 9.4
Test of new control during a start with the chamber temperature at 110°C.

In figure 9.5 the set point of the chamber temperature was changed to 90°C. This to test the robustness of the start function and for future implementations with a fan where the chamber temperature might be lowered, see section 10.3. Also here the start function worked leaving the web temperature just above 84°C after 13 seconds.

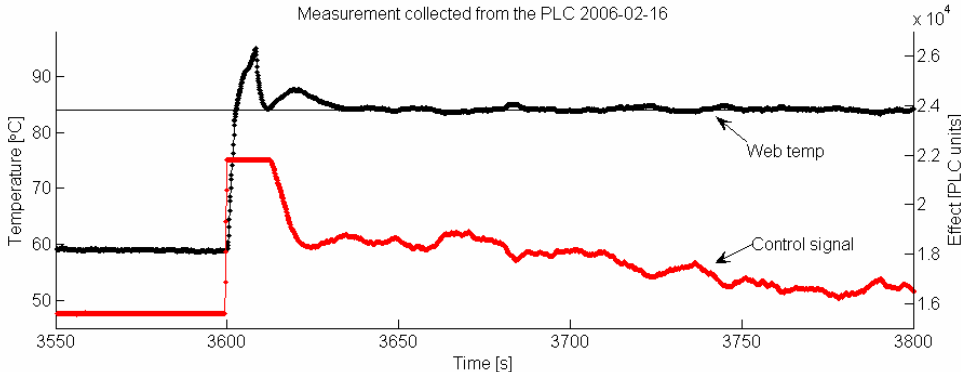

Figure 9.5
Test of new control during a start with the chamber temperature at 90°C.

In figure 9.6 the limitation of the chamber temperature was removed allowing the machine to be started at any temperature. Here the machine was started almost immediately after the stop providing a chamber temperature of about 120°C. The start function now generates a much lower value but still leaves the web temperature at 84°C.

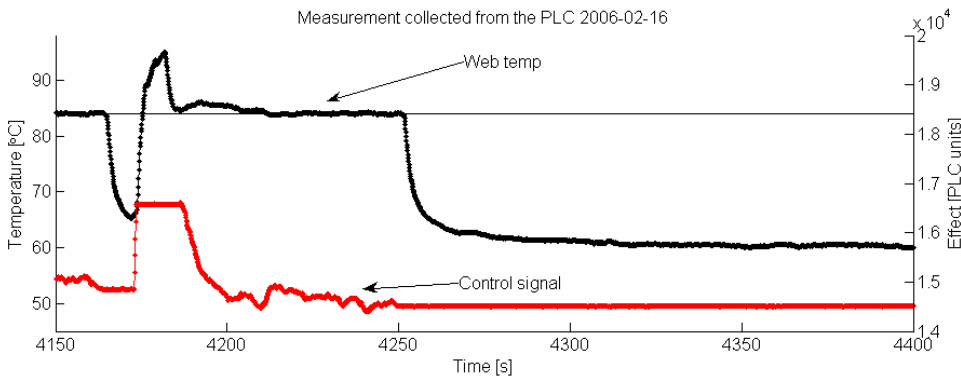

Figure 9.6
 Test of new control during a start with the chamber temperature at 120°C

9.3 Improvement

Figure 9.7 shows a comparison between the old and new implementation of the control. The left plot shows starts where the chambers initial temperature was 98°C and in the right plot the initial temperature was 110°C. It shows how the new control reduces the overshoot and therefore the time spent at wrong temperatures, minimizing the disposal of packages.

The error in temperature is decreased about three times and the web temperature reaches its set point at least twice as fast with the new implementation.

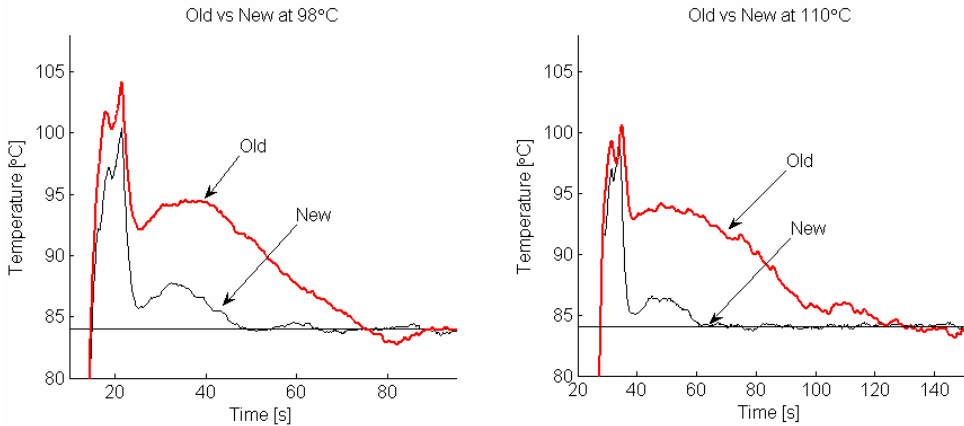

Figure 9.7
 Plot of original versus new control at different initial chamber temperatures

10. Alterations of the TFA A1 200/250

10.1 Different package sizes

This thesis studies the machines TFA 200 and TFA 250, these machines produce packages of sizes 200 and 250 ml. Both machines use the same width of material and the same heating chamber, the main difference between them is the last step of the production where the packages are shaped and sealed. Other machines manufacture other package sizes and these machines are using packaging material with different widths.

Different widths will mostly affect the energy needed to heat the material due to the difference in mass.

During start up the difference in mass will force alterations to the function described in section 7.3. Different widths of packaging material will consume different amount of energy in order to be heated to the desired set point.

The system describing the web temperature in section 6.1 will be altered due to the difference in mass flow. In order to get the most effective control the parameters of the PI controller must be re-tuned using a step response test.

During production the chamber temperature will be affected so that a wider material will need a higher temperature and vice versa. This chamber temperature difference will be seen when the machine is stopped so that a wider material will result in more blisters as a result of the higher initial temperature. Besides this the appearance of the chamber during stops will probably not be significantly changed.

10.2 Different machine speed

The TFA A1 machine is a newly developed platform and is still to be improved. Future upgrades will be to increase the production rate, i.e. the material will pass the heating chamber at a higher speed. Below follows a discussion concerning the effects of the increased speed, how the characteristics of the chamber might change and how the tuning of the control should be modified.

Whether the speed can be increased or not is determined by the amount of energy that needs to be transferred to the material. Since the amount of time the material spends inside the chamber will be decreased as the speed is increased it is necessary to amplify the chamber temperature. In the 200/250 set up the capacity used by the heating elements, measured in PLC units, is about 16 000 which corresponds to half of the maximum effect (32 000). Us-

ing this as guidance there is room for speed increments, since the elements are only switched on for half of the time.

The levels of the start up function, section 7.3, must be increased to counteract the increased speed. The faster speed leads to shorter start up time therefore shorter time to increase the chamber temperature to working level. The largest amount of energy needed is during start up. If the maximum energy supplied by the elements is insufficient an alternative would be to increase the speed gradually during starts.

With the machine running faster the dead time of the system as well as the stationary gain will decrease. Both these effects lead to a more stable system to control. To tune the PI parameters a step response is recommended.

The higher working temperature of the chamber will lead to more blisters during stops. One way of solving this might be by introducing stop control, mentioned in section 7.4. The PI parameters for the chamber temperature are the same as for the machine running at normal speed since the machine is stopped.

10.3 Introduction of a fan

Section 3.2 contained a short discussion regarding the blisters on the material that occurs during a stop. These blisters damage the material seriously and upon the next start of the machine the material exposed to blisters will be discarded. With software modifications the only way to solve this problem is by gradually lowering the web speed so that the chamber temperature decreases, described in section 7.4.

The temperature variations within the chamber seem to be quite big and non deterministic, this can be seen in figures 5.5, 5.7 and 5.15. If the temperature distribution in the chamber was more even, the temperature of the chamber during stops could be lowered. This since the temperature could be guaranteed to be over the dew point of the hydrogen peroxide everywhere in the chamber at a lower set point.

A suggested hardware configuration of the chamber is to install some sort of fan; this will increase the movement of the air-peroxide mixture within the chamber. This will probable amplify the heat transferred from the elements to the material so that the working temperature of the chamber will be lowered. As a result of this the decrease of temperature needed when the machine is stopped, to avoid blisters, is less. Thus minimizing the amount of blisters.

The fan might also enable the chamber temperature to be lowered during stops so that the initial peaks of the web temperature can be minimized. This since they are a direct result of chamber temperature at the point where the machine is started.

With the fan installed the levels of the start up function can probably be lowered, since the exchange between the elements and the material is increased.

Both of the PI controller's parameters must be tuned since the stationary gain of the process increases. The step response test will produce initial parameters for tuning.

10.4 Different probe position

The position of the web temperature probe is questioned as well as the actual probe design. Instead of the current method a pyrometer may be installed measuring the temperature of the first roller following the heating chamber, positioned in the filling tower. This might enable more accurate and disturbance free measurement of the temperature. Another benefit of a new probe is the removal of direct contact between the probe and the material.

Installing a new probe at the new location introduces some side effects of the controlled system. The distance between the chamber and the measurement point will be increased, thus increasing the time delay of the process. Increment of time delay always affects the closed loop system negatively making it harder to control. The new measurement technique, measuring the roller instead of the material surface also introduces measuring delay. It might also decrease the stationary gain due to greater energy losses between the chamber exit and the measurement probe than before.

An attempt to predict whether these effects will be acceptable or not has been performed. This by simulating the system with the additional estimated time delay and the reduced stationary gain. The new probe will be located about 50 centimetres further down the material path, measured from the current probe. Since the machine speed is about 0.4 metres per second this will introduce an additional time delay of $0.5 / 0.4 = 1.25$ seconds. The new measurement technique also adds to the time delay, how much is dependent of the heat transfer capacity between the material and the roller. In the simulation the time delay was increased 2.5 seconds to accumulate both these time delays. The stationary gain of the process was reduced with 10 percent. The simulation was performed as a step response test of the closed loop system, the result is shown in figure 10.1.

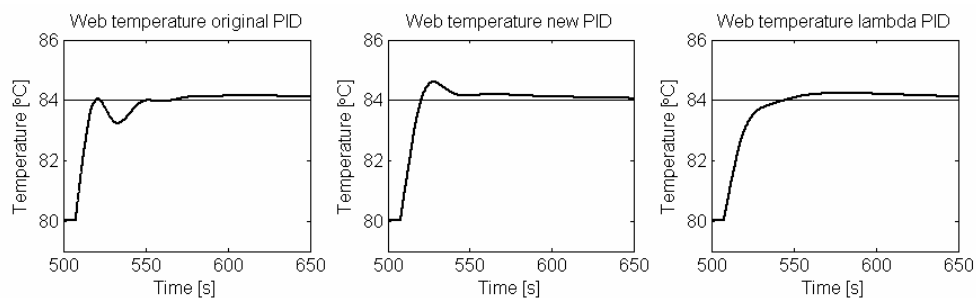

Figure 10.1
Simulating the effect of alternative probe placement

The simulation showed that the new placement gives an acceptable closed loop performance. It can be seen that either of the new (table 7.2) or lambda (table 7.1) PID's can be used as good start values for further tuning.

The suggested new start control (see section 7.3) must be modified to compensate for the new time delay. The introduced time delay by the new probe must be added to the current 13 seconds.

11. Tuning manual

The control derived in this thesis only applies for the studied material width and therefore experiences and conclusions from this work are put together and a manual for tuning of other machines and conditions is developed. The manual will be divided into four different stages; measurements, control design, implementation and validation.

11.1 Measurements

As in this thesis, tests of the system must be performed for a systematic approach. A basic step response test will be enough to derive initial parameters for the tuning of the control. In order to identify the system from a step response test it is necessary to measure the actual signals to and from the PLC. The easiest way to do this is to attach an analogue output module card to the PLC rack and measure the signals from it with an external logger. The output card must be correctly configured so that the values in the PLC that will be between 0-32000 units will correspond to a voltage between 0-10 volts from the card.

Signals that should be measured from the PLC are the two temperatures from the web and the chamber, called 7AI and 8AI. The value of these will be the measured temperature times ten and to obtain higher resolution in the measurement these analogue inputs should be multiplied by 10 and set to the outputs of the card. This gives that the measured voltage should be multiplied with 320 to get the temperature represented as seen from the controller.

Two more signals should be logged and these are the outputs (Control Values) from the web and chamber controllers. The outputs from the controllers will be a value between 0-32000 and should be assigned, moved, to outputs on the card. The measured voltage should be multiplied with 3 200 to get the correct values for identification.

When conducting the step response tests the alarm limits for the web temperature should be either increased or removed, otherwise the machine will stop. The following memory bits in the PLC are associated with the alarm; M 2539, M 2536.

To perform the step the active controller should be set in manual mode. Minimum slew time, lower clamp and dead band (\pm) should be set to zero. The upper clamp could be set at a desired level to guarantee that the material won't catch on fire. Suggested values are 27 000 for the web and 6 000 for the chamber.

Step sizes should be big enough to get a good signal to noise ratio but not too big so that the test excites the linear region. The resulting step in temperature should go from 80°C to 90°C for the web and from 90°C to 100°C for the chamber.

11.2 Control design

From the process reaction curve the process gain K , the process dead time t_D and the process time constant t_C can be estimated as described in section 4.1.1. With this calculated the lambda method, described in section 4.2, provides good start parameters for the P and I part of the controller. The D part is set to zero. A recommended value for the lambda factor, κ , is one. The values attained from the lambda method gives the P and I parts from equation 7.1, i.e. $P = K_C$, $I = K_C / T_i$.

11.3 Implementation

The new control structure is now ready to be implemented and tested, this should be done as described in section 8. When testing the new control the alarm limits described in section 11.1 should be increased or removed. In section 10 different modifications of the machine are described and these should be taken into consideration when implementing the start up control described in section 7.3.

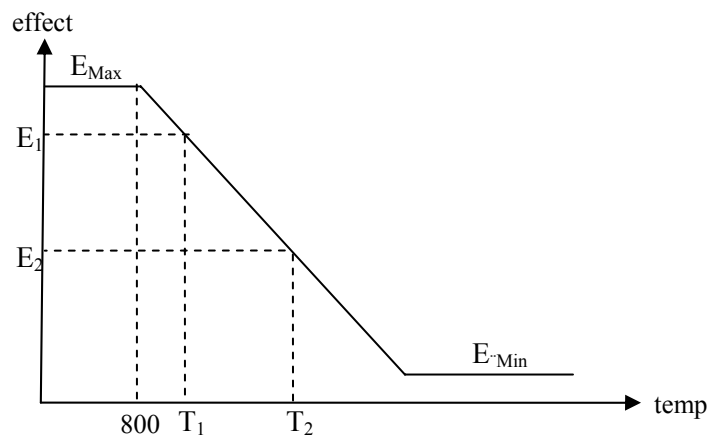

Figure 11.1
Tuning of the start up function

If, for example, the control structure is modified for handling wider material the start up function should be modified as more energy is needed to raise the temperature to the desired set point. The only way to fine tune this function is to test it with the machine starting from different chamber temperatures and adjusting the upper and lower limits until desired behaviour is attained. The start up function can be calculated approximately by starting the machine from two different initial chamber temperatures, for example 98°C and 110°C. The function should then be implemented as figure 11.1 implies. See also section 7.3.

The settings for the PI controller should be done as described in section 8 but with the calculated parameters from section 11.2. The upper limit for the web controller might be increased if further effect is needed. Once implemented in the PLC step response tests should be performed for validation and fine tuning. By tuning the lambda factor the desired behaviour of the closed loop system can be attained. By decreasing the lambda factor the control will be more aggressive and vice versa. Watch out for overshoots or too slow behaviour.

12. Summary

On the packaging machine Tetra Pak A1 a heating box is used to sterilize the packaging material. This is done by passing the material through a bath of hydrogen peroxide and then vaporizing the liquid in the heating box. The heating is done by three resistive elements that pass their energy by convection and radiation to the packaging material. The elements are controlled by a computer that calculates and adjusts the amount of current running through them. As feedback to the computer two measurements probes measure the air temperature inside the box and the surface temperature on the material after the box. When the machine is stopped, during a production pause, the air temperature inside the box is controlled to 98°C. When the machine is producing packages the surface temperature of the material is controlled to 84°C, at this temperature the material will be sterile.

Problems occur due to temperature variations on the web of the packaging material. During normal production the temperature variations are small and acceptable. At starts and stops, overshoots cause material damages and undershoot results in peroxide residues forcing disposal of packages.

This master thesis gives a solution on how to improve the control of the Tetra Pak A1 packaging machine. This was done through a series of different tests on the heating chamber. Through these tests a new control strategy could be derived, dividing the algorithm into three stages: start, running and stop. Linking them together reduced length and height of the overshoots. Another improvement compared to the old control is that it adopts the starting output to the prevailing conditions of the chamber temperature. This, new control strategy, allows the machine to be started from any chamber temperature and therefore shortening the minimum stoppage time. This combined with a new set of PID-parameters gave the desired effect of a faster control.

Included within the thesis is a tuning manual developed for future alterations on the A1 machine. Discussions concerning these alterations are performed in an academic way as no practical experiments could be performed on the machine. With the help of these discussions a new control can be derived optimizing it for the new circumstances.

13. References

- [R.0] www.tetrapak.com
- [R.1] www.delaval.com
- [R.2] www.sidel.com
- [R.3] GE Fanuc Automation (1997) *Series 90-30/20/Micro Programmable controller Reference manual*. GE Fanuc, North America
- [R.4] Program code extracted from the PLC.
- [R.5] Johansson, Rolf (2004) *System modelling and identification*. Prentice Hall, Englewood Cliffs.
- [R.6] Torkel, Glad; Lennart, Ljung (1989) *Reglerteknik grundläggande teori*. Studentlitteratur, Lund.
- [R.7] Matlab help instructions.
- [R.8] Forsman, Krister (2005) *Reglerteknik för processindustrin*. Studentlitteratur, Sverige.

14. Appendices

The three following appendices contain printouts of the PLC implementation used for generating the examples in this thesis. This can be seen as guidelines when implementing the new control structure in the current logic.

1. Initiation of regulators
This structure was placed in a separate subroutine. It should be called from the main program.
2. Control implementation
This structure was placed in a separate subroutine. It should be called from the main program.
3. Used for overriding existing control
This is modifications in the existing SupReg subroutine. The modifications are marked with bold characters.

Appendix 1

```

[ START LD SUBROUTINE  SETREG ]
[ VARIABLE DECLARATIONS ]
[ START OF SUBROUTINE LOGIC ]

<< RUNG 3 STEP #0001 >>

FST_SCN +-----+
+---] [---+MOVE+-----+MOVE+-----+MOVE+-----+<+>
          |INT|
CONST  -+IN Q+-%R09626  CONST -+IN Q+-%R09627  CONST -+IN Q+-%R09628
+00010 |LEN| +00002 |LEN| +00000 |LEN|
        |00001|        |00001|        |00001|
        +-----+        +-----+        +-----+

<< RUNG 4 STEP #0006 >>

+<+>-----+MOVE+-----+MOVE+-----+MOVE+-----+<+>
          |INT|
CONST  -+IN Q+-%R09629  CONST -+IN Q+-%R09630  CONST -+IN Q+-%R09631
+00000 |LEN| +00000 |LEN| +06000 |LEN|
        |00002|        |00001|        |00001|
        +-----+        +-----+        +-----+

<< RUNG 5 STEP #0011 >>

+<+>-----+MOVE+-----+MOVE+-----+MOVE+-----+<+>
          |INT|
CONST  -+IN Q+-%R09632  CONST -+IN Q+-%R09633  CONST -+IN Q+-%R09634
+00000 |LEN| +07500 |LEN| +00000 |LEN|
        |00001|        |00001|        |00001|
        +-----+        +-----+        +-----+

<< RUNG 6 STEP #0016 >>

+<+>-----+MOVE+-----+MOVE+-----+MOVE+-----+<+>
          |INT|
CONST  -+IN Q+-%R09635  CONST -+IN Q+-%R09636  CONST -+IN Q+-%R09637
+27000 |LEN| +00000 |LEN| +00000 |LEN|
        |00001|        |00001|        |00001|
        +-----+        +-----+        +-----+

<< RUNG 7 STEP #0021 >>

+<+>-----+MOVE+-----+MOVE+-----+MOVE+-----+<+>
          |INT|
CONST  -+IN Q+-%R09638  CONST -+IN Q+-%R09639  CONST -+IN Q+-%R09653
+00004 |LEN| +00000 |LEN| +00000 |LEN|
        |00001|        |00001|        |00001|
        +-----+        +-----+        +-----+

<< RUNG 8 STEP #0026 >>

+<+>-----+MOVE+-----+
          |INT|
CONST  -+IN Q+-%R09654
+00900 |LEN|
        |00001|
        +-----+

```

```

<< RUNG 9 STEP #0028 >>
FST_SCN +-----+
+--] [---+MOVE+-----+MOVE+-----+MOVE+-----<+>
      |INT|
      +-----+
CONST  -+IN Q+-%R09667  CONST  -+IN Q+-%R09668  CONST  -+IN Q+-%R09669
+00011 |LEN|          +00002 |LEN|          +00000 |LEN|
      |00001|          |00001|          |00001|
      +-----+          +-----+          +-----+

<< RUNG 10 STEP #0033 >>
+-----+
+>+-----+MOVE+-----+MOVE+-----+MOVE+-----<+>
      |INT|
      +-----+
CONST  -+IN Q+-%R09670  CONST  -+IN Q+-%R09671  CONST  -+IN Q+-%R09672
+00000 |LEN|          +00000 |LEN|          +04000 |LEN|
      |00002|          |00001|          |00001|
      +-----+          +-----+          +-----+

<< RUNG 11 STEP #0038 >>
+-----+
+>+-----+MOVE+-----+MOVE+-----+MOVE+-----<+>
      |INT|
      +-----+
CONST  -+IN Q+-%R09673  CONST  -+IN Q+-%R09674  CONST  -+IN Q+-%R09675
+00000 |LEN|          +01000 |LEN|          +00000 |LEN|
      |00001|          |00001|          |00001|
      +-----+          +-----+          +-----+

<< RUNG 12 STEP #0043 >>
+-----+
+>+-----+MOVE+-----+MOVE+-----+MOVE+-----<+>
      |INT|
      +-----+
CONST  -+IN Q+-%R09676  CONST  -+IN Q+-%R09677  CONST  -+IN Q+-%R09678
+06000 |LEN|          +00000 |LEN|          +00000 |LEN|
      |00001|          |00001|          |00001|
      +-----+          +-----+          +-----+

<< RUNG 13 STEP #0048 >>
+-----+
+>+-----+MOVE+-----+MOVE+-----+MOVE+-----<+>
      |INT|
      +-----+
CONST  -+IN Q+-%R09679  CONST  -+IN Q+-%R09680  CONST  -+IN Q+-%R09694
+00004 |LEN|          +00000 |LEN|          +00000 |LEN|
      |00001|          |00001|          |00001|
      +-----+          +-----+          +-----+

<< RUNG 14 STEP #0053 >>
+-----+
+>+-----+MOVE+-----+
      |INT|
      +-----+
CONST  -+IN Q+-%R09695
+01100 |LEN|
      |00001|
      +-----+

[   END OF SUBROUTINE LOGIC   ]

```

Appendix 2

```

[ START LD SUBROUTINE  REGTEST ]
[ VARIABLE DECLARATIONS ]
[ START OF SUBROUTINE LOGIC ]

<< RUNG 3 STEP #0001 >>
ALW_ON %M3500
+--] [-----] [-----] [-----] ( )--

<< RUNG 4 STEP #0003 >>
SUPI198 %M3502 +-----+ %M3501
+--] [-----]/[---+ TMR +-----] ( )--
|           | 0.10s |
|           +-----+
|           |PV |
|           +-----+
|           |R09617|
|           +-----+

<< RUNG 5 STEP #0007 >>
%M3501 %M3502
+--] [-----] (S)--

<< RUNG 6 STEP #0009 >>
SUPI198 %M3502
+--] [-----] (R)--

<< RUNG 7 STEP #0011 >>
SUPI198 %M3503
+--] [-----] (^)--

<< RUNG 8 STEP #0013 >>
%M3503 %M3506 +-----+ %M3506
+--] [---+ GE | +-----] ( )--
|           | INT |
|           +-----+
| B328 -+I1 Q+ |
|           |   |
|           |   |
|           +-----+
|           |I2 |
|           +-----+
|           |R09624|
|           +-----+

<< RUNG 9 STEP #0016 >>
%M3503 %M3506 +-----+
+--] [-----]/[---+MOVE +---
|           | INT |
|           +-----+
|           |IN Q+-%R09624|
|           +-----+
|           |LEN |
|           +-----+
|           |00001|
|           +-----+

<< RUNG 10 STEP #0019 >>
%M3506 +-----+ +-----+ +-----+
+--] [---+ SUB +-----] [---+ MUL +-----] [---+ SUB +-----]
|           | INT | |           | INT | |           | INT |
|           +-----+ +-----+ +-----+
| B328 -+I1 Q+-%R09707 %R09707-+I1 Q+-%R09708 CONST -+I1 Q+-%R09624
|           |   | |           |   | |           |   |
|           |   | |           |   | |           |   |
|           +-----+ +-----+ +-----+
|           |I2 | |           |I2 | |           |I2 |
|           +-----+ +-----+ +-----+
|           |R09708-+I2 |
|           +-----+

```

```

<< RUNG 11 STEP #0023 >>
%M3506 +-----+
+---] [---+ GE_
          |INT|
          |
%M09624-+I1  Q+-----+MOVE_+
          |   |   |INT|
          |   |   |
CONST  -+I2  |   |CONST -+IN  Q+-%R09624
+22250 +-----+ +22250 |LEN|
          |   |   |00001|
          +-----+

<< RUNG 12 STEP #0026 >>
%M3506 +-----+
+---] [---+ LE_
          |INT|
          |
%M09624-+I1  Q+-----+MOVE_+
          |   |   |INT|
          |   |   |
CONST  -+I2  |   |CONST -+IN  Q+-%R09624
+15000 +-----+ +15000 |LEN|
          |   |   |00001|
          +-----+

<< RUNG 13 STEP #0029 >>
SUP1198 %M3502 +-----+                                     %M3504
+---] [-----]/[---+MOVE_+-----+-----+-----+-----+-----+
          |INT|
          |
%M09624-+IN  Q+-%R09639
          |LEN|
          |00001|
          +-----+

<< RUNG 14 STEP #0033 >>
%M3500 SUP1198 +-----+
+---] [-----] [---+ PID_+
          |IND|
          |
CONST  -+SP  CV+-%R09625
+00840
          |
%AI0008-+PV
          |
%M3504
+---] [-----+MAN
          |
ALW_OFF
+---] [-----+UP
          |
ALW_OFF
+---] [-----+DN
          |
          +-----+
          %R09626

<< RUNG 15 STEP #0039 >>
ALW_ON +-----+                                     %M3505
+---] [---+ GT_
          |INT|
          |
B328  -+I1  Q+-----+MOVE_+
          |   |   |INT|
          |   |   |
CONST  -+I2  |   |CONST -+IN  Q+-%R09680
+01010 +-----+ +00000 |LEN|
          |   |   |00001|
          +-----+

```



```

  << RUNG 16  STEP #0043 >>
%M3500  SUP1198  +-----+
+---] [-----]/[---+ PID +-
                | IND |
                |-----|
                CONST --+SP CV+--%R09666
                +00980 |
                B328  --+PV
%M3505
+---] [-----+MAN
ALW_OFF
+---] [-----+UP
ALW_OFF
+---] [-----+DN
                |-----|
                %R09667

  << RUNG 17  STEP #0049 >>
%M3500  SUP1198  +-----+
+---] [-----] [---+MOVE +-
                | INT |
                |-----|
                %R09625--+IN Q+--%R05649
                | LEN |
                |00001|
                +-----+

  << RUNG 18  STEP #0052 >>
%M3500  SUP1198  +-----+
+---] [-----]/[---+MOVE +-
                | INT |
                |-----|
                %R09666--+IN Q+--%R05647
                | LEN |
                |00001|
                +-----+
[     END OF SUBROUTINE LOGIC     ]

```