

Student thesis series INES nr 340

# The water crisis in Gaborone

Investigating the underlying factors resulting in the 'failure' of the Gaborone Dam, Botswana



*Source: B. Farrington, 2015*

**Elisabeth Maria Farrington**

---

2015  
Department of  
Physical Geography and Ecosystem Science  
Lund University  
Sölvegatan 12  
S-223 62 Lund  
Sweden



Elisabeth Maria Farrington (2015).

***The Water Crisis in Gaborone: Investigating the underlying factors resulting in the 'failure' of the Gaborone Dam, Botswana***

Bachelor degree thesis, 15 credits in *Physical Geography and Ecosystem Science*

Department of Physical Geography and Ecosystem Science, Lund University

Level: Bachelor of Science (BSc)

Course duration: *March* 2015 until *June* 2015

Disclaimer

This document describes work undertaken as part of a programme of study at the University of Lund. All views and opinions expressed herein remain the sole responsibility of the author, and do not necessarily represent those of the institute.

# The water crisis in Gaborone

Investigating the underlying factors resulting in the ‘failure’ of the  
Gaborone Dam, Botswana

---

Elisabeth Maria Farrington

Bachelor thesis, 15 credits, in *Physical Geography and Ecosystem Science*

Supervisors:

Abdulghani Hasan & Harry Lankreijer

Exam committee:

Andreas Persson & Petter Pilesjö

Course coordinator:

Jonas Ardö

## **List of Abbreviations**

**CSO**- Central Statistics Office

**DMS**- Department of Meteorological Services

**FAO**- Food and Agriculture Organisation of the United Nations

**IPCC**- Intergovernmental Panel on Climate Change

**MEWT**- Ministry of Wildlife, Environment and Tourism

**NSCWP**- North South Carrier Water Project

**SADC**- Southern Africa Development Community

**TAMSAT**- Tropical Applications of Meteorology using SATellite data and ground-based observations

**USGS**- United States Geological Survey

**WUC**- Water Utilities Corporation

## **Abstract**

Botswana is an arid country endemic to drought. The major water supply in the capital Gaborone, the Gaborone Reservoir, has received a failed status early this year due to diminishing water levels which have fallen below six percent of the total potential volume in 2014. However, there seems to be no official consensus as to what has caused this extreme decrease in volume. Water scarcity can have great impacts in regards to the economy, development and national security of a country and it is important to grasp the cause of the problem in order to solve it in the most efficient way. By analysing data time series for temperature, rainfall and consumption as well as performing a spatial analysis over the catchment area it was possible to identify the changes that have occurred in the catchment area, the climate and the domestic consumption over the last decade. Poor data resolution and a lack of statistical significance mean that no concrete conclusions can be drawn. In order to sustain a sustainable water future, it is important that water conservation is promoted and that the second phase of the North South Water Carrier Project (with the purpose of pumping water from reservoirs in eastern Botswana and South Africa to Gaborone) keeps to the original timeline and fixes the faults within the pipeline.

**Keywords:** Gaborone Reservoir, drought, catchment area, climate change, consumption

## Sammanfattning

Torka är mycket vanligt i Botswana. I huvudstaden Gaborone har Gaboronedammen klassats som ett misslyckande eftersom vattennivån har sjunkit till under sex procent av den potentiella volymen under 2014. Det finns inte någon officiell enighet om vad som har orsakat denna extrema volymminskning. Vattenbrist kan ha negativa konsekvenser för ett lands ekonomi, utveckling och till och med för den nationella säkerheten eftersom grannländer ofta tycker olika när det gäller vem som ska få utnyttja delade vattendrag. Det är viktigt att förstå orsaken till volymminskningen för att lösa problemet på bästa och effektivaste sätt. Under studien har både en rumslig analys och en analys av tidsserier för data gällande nederbörd, temperatur och konsumtion genomförts. Detta har gjort det möjligt att se vilka förändringar som har skett sedan Gaboronedammen konstruerades 1965. På grund av brister i dataupplösning och trender utan statistisk signifikans så går det inte att dra några slutsatser. För att uppnå en hållbar vattentillgänglighet i Gaborone i framtiden så är det väsentligt att vattenvård främjas och att vattenförsörjning till Gaborone från Gaboronedammen kompletteras med pålitlig vattentillförsel från andra dammar i Botswana, dvs. NSCWP rörledningarna lagas och underhålls.

**Nyckelord:** Gaboronedammen, torka, dräneringsområde, klimatförändring, konsumtion

## **Acknowledgements**

This study was carried out during ten weeks. The limited timeframe and working remotely from Sweden meant that data collection was constrained. I am therefore grateful to all those who assisted with sourcing and supplying of relevant data not available from the internet. I am very grateful for all the support I received from my family and friends, especially those whom I spent many long hours with in the schools computer labs. I would also like to thank my supervisors for their guidance and especially Mr. Farai Marumbwa and Mr. Alfred Lefaphane at the Department of Meteorological Services in Gaborone for guidance on how to best analyse the TAMSAT data series and for providing rainfall records.

## **Table of Contents**

<b>1. The Global Water Dilemma.....</b>	<b>1</b>
<b>2. Water Scarcity in the Gaborone Reservoir, Botswana .....</b>	<b>2</b>
<b>3. Aim and Objectives .....</b>	<b>4</b>
<b>4. The Study Area .....</b>	<b>4</b>
<b>5. Materials and Methods .....</b>	<b>6</b>
<b>5.1 Catchment Area.....</b>	<b>6</b>
<b>5.2 Climate .....</b>	<b>7</b>
<b>5.3 Consumption.....</b>	<b>9</b>
<b>6. Results.....</b>	<b>10</b>
<b>6.1 Catchment Area.....</b>	<b>10</b>
<b>6.2 Climate .....</b>	<b>11</b>
<b>6.3 Consumption.....</b>	<b>14</b>
<b>7. Discussion .....</b>	<b>16</b>
<b>7.1 Catchment Area.....</b>	<b>16</b>
<b>7.2 Climate .....</b>	<b>17</b>
<b>7.3 Consumption.....</b>	<b>18</b>
<b>7.4 Planning for the Future .....</b>	<b>19</b>
<b>8. Sources of Error and Suggestions for Improvement.....</b>	<b>21</b>
<b>8.1 Catchment Area.....</b>	<b>21</b>
<b>8.2 Climate .....</b>	<b>22</b>
<b>8.3 Consumption.....</b>	<b>22</b>
<b>9. Conclusions.....</b>	<b>22</b>
<b>10. Bibliography .....</b>	<b>23</b>
<b>11. Appendix 1.....</b>	<b>26</b>
<b>11.1 FAO evapotranspiration.....</b>	<b>26</b>



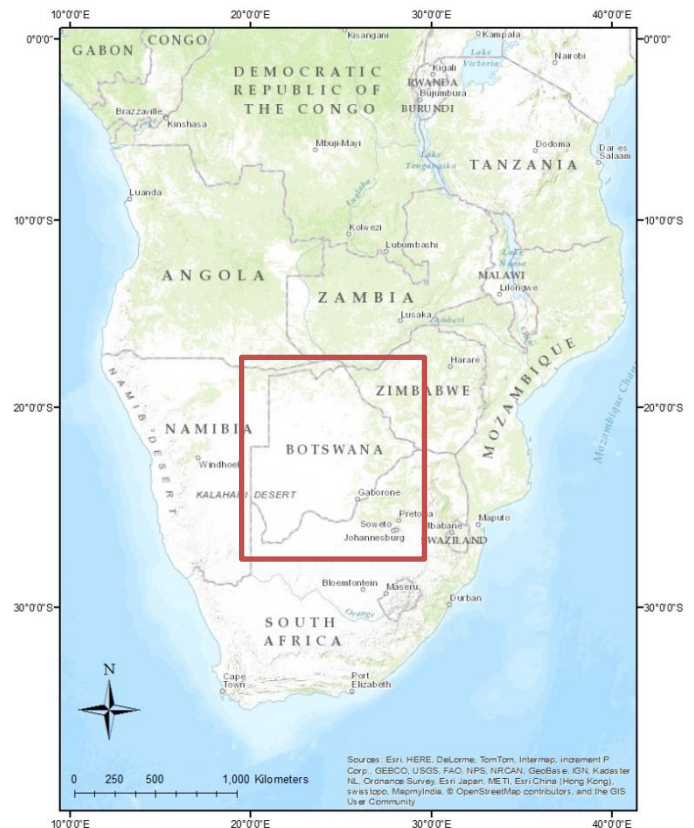
## 1. The Global Water Dilemma

Water is a complicated resource to define. Is it finite, as there is a fixed volume of it on the planet? Is it renewable, as it is constantly changing state within the hydrological cycle? One thing we can say with confidence is that water is essential for all living organisms, a basic necessity for human life, and we must be weary of how we regard this precious resource (Vitousek et al. 1997). Freshwater constitutes only three percent of the earth's total water supply, 0.3% of which is found as surface water (NOAA (a) 2014). Regardless of this very limited supply, there are still frequent cases of water pollution where water is contaminated by industrial waste, untreated human waste and pesticides amongst others, worsening the water quality (Palaniappan et al. 2010). Despite attempts to assert greater human control over natural water sources by manipulating rivers and constructing dams and reservoirs, water scarcity is still discernable in many parts of the world (Rijsberman 2006; NOAA (b) 2015). As the global population is growing exponentially from the current seven billion to an estimated 9.3 billion by 2050, it is probable that this problem will only worsen (Lee 2011).

The decline in water quality and quantity, also referred to as the global water crises, was in 2014 ranked as one of the top five "Global Risks of Highest Concern" by the World Economic Forum amongst other concerns such as income disparity and the failure to mitigate or adapt to climate change (World Economic Forum 2014). Water availability is directly related to food production and water scarcity would consequently result in food shortages (Eckardt et al. 2009). As the inability to access freshwater has a direct impact on the survival of communities, water scarcity threatens not only to impede the further development of nations, but also increases the risk of water conflicts on a local and an international scale (Vitousek et al. 1997; Madulu 2003). In fact, there are already several reported cases of water conflicts as of the 21<sup>st</sup> century. An actual African example would be that of the Grand Ethiopian Renaissance Dam, a costly project that intends to expand the generation of hydroelectricity in Ethiopia. Not only would the dam benefit the population of Ethiopians with no access to electricity (approximately 83% of the population), but exported surplus would be economically beneficial too (Hammond 2013). However, the dam proposal has been strongly opposed by Ethiopia's downstream neighbours Egypt and Sudan, as it would limit their available water resources. There have even been suggested threats of military interference if the project were to continue (Abebe 2014).

## 2. Water Scarcity in the Gaborone Reservoir, Botswana

Botswana, a sub-Saharan, semi-arid nation is no stranger to the discourse surrounding a sustainable water future (*Figure 1*). Water distribution within the country is uneven due to approximately 70% of the nation being covered by the Kalahari Desert, and drought is considered endemic to the country (Swatuk and Rahm 2004; Juana 2014). The Batswana (plural form referring to Botswana natives), regard rainfall highly within their culture and customs. The word 'Pula', translated to English as 'rainfall' or 'let there be rain', is the national cry of Botswana, as well as being the name given to their currency and the equivalent of saying cheers when making a toast (Denbow and Thebe 2006). Pula brings prosperity to the nation and the superstitious believes of many Batswana become more prominent during drought years (Gewald 2001).



**Figure 1** Botswana is a landlocked state in Southern Africa. Source: ArcGIS online

The country's capital city, Gaborone, is located in south-eastern Botswana (*Figure 2*). A nation with a high dependency on surface water, Gaborone is no different with, until recently, all of the city's water being abstracted from the Gaborone Reservoir (Meigh 1995). Since the new millennium, there has been a decline in the total volume of the Gaborone Reservoir, the leading supplier of water for the capital city Gaborone and the greater area. The reservoir is able to hold 141.1 million cubic metres when at full capacity, but in December 2014 the reservoir was reduced to roughly 8.5 million cubic meters (6% of the total capacity) and it was no longer possible to pump water out of it (Du Plessis and Rowntree 2003). When water levels had fallen below 6% of the total capacity, the WUC declared the reservoir as failed as it was unable to fulfil its purpose of providing water to Gaborone city. Though local newspapers theorize that lack of rainfall is the leading cause of this problem, it is still uncertain as to what is causing this drop in water levels and rumours have spread throughout the city associating the decreasing water levels with black magic and witchcraft (Gewald 2001).



**Figure 2** Major towns and cities in Botswana

In his ‘State of the Nation address’ in 2013, Botswana’s president emphasised the importance of shared watercourses stating that they would, in the future, become the country’s primary source of reliable water (Khama 2013). Botswana shares watercourses with Angola, Lesotho, Malawi, Namibia, South Africa, Tanzania, Zambia and Zimbabwe, of which all the nations are members of the Southern African Development Community (SADC). At present the community has produced a protocol for shared watercourses with the intention of promoting sustainable and peaceful water management within the region (SADC 2012). It is vital for Botswana that these peaceful relations continue if they are to be heavily reliant on water from these sources.

Since independence in 1966, the government of Botswana has been involved in many highly subsidised programmes aiding in low-cost water provision which in some cases are even free of charge. This initiative amongst others is the reason behind the great reduction of poverty throughout the country and subsequently high rates of development (Sebudubudu 2010). If the water crisis continues, a reduction in subsidies may be inevitable as capital must be injected into other sectors such as the improvement of water infrastructure. This could have a huge impact on Botswana’s development including the standard of living of many of its inhabitants.

There currently seems to be no consensus to what has caused the fluctuations in the reservoir volume. This information is critical as water scarcity will not only threaten to stunt development but may also be a matter of national security. In order to combat water scarcity efficiently it is important to know the possible causes especially since the IPCC suggest that

arid regions are predicted to become even drier (Kirtman et al. 2013). It is for these reasons that the intention of this study is to investigate what factors are causing the discernable decrease in volume of the Gaborone Reservoir.

### **3. Aim and Objectives**

The aim of this study is to investigate the factors that have led to the decline of the volume of the Gaborone Reservoir over the last ten years with the intention of ranking each factor by importance. Measures currently taken by the Botswana government will be discussed, as well as additional suggestions as to what may prevent further water scarcity in the city of Gaborone. The study aims to answer the questions:

- How have changes catchment size, climate and consumption over the last decade impacted the amount of water stored in the Gaborone Reservoir?
- What methods have been put in place to decrease the stress placed on the Gaborone Reservoir, and what are the future prospects for a city with no water?

### **4. The Study Area**

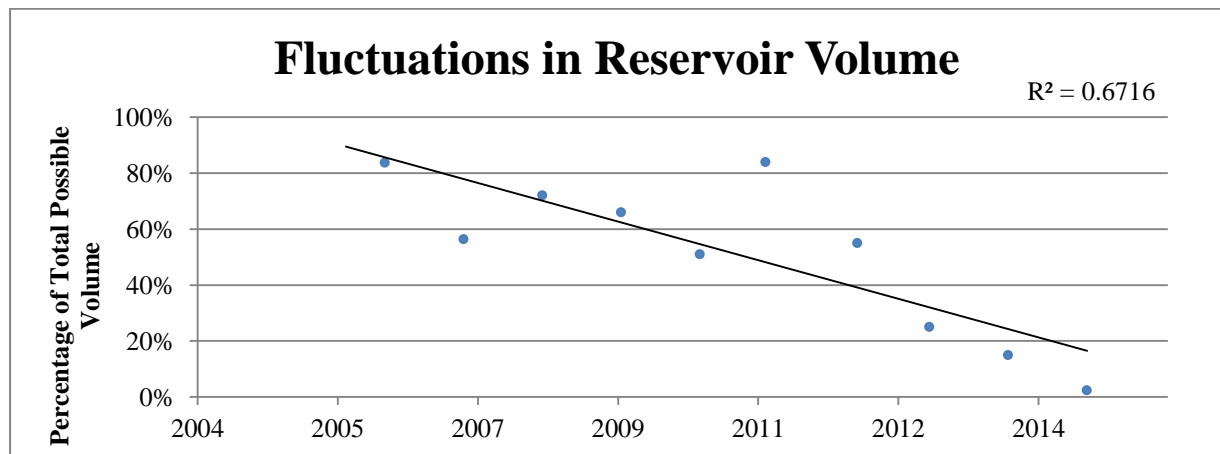
Botswana, bisected by the Tropic of Capricorn and landlocked by four countries: South Africa, Namibia, Zambia and Zimbabwe (see *Figure 1* and *2*), can be classified for the most part as having a hot, arid steppe climate (BSh) whilst the south-western corner matches the requirements of a hot, arid desert (BWh) according to the Köppen-Geiger classification system (Peel et al. 2007). The climate can be characterized into two specific seasons, the dry season and the rainy season. The dry season extends from April to October with cooler air temperatures and little to no rainfall. The rainy season occupies the remaining months, majority of rainfall occurring in December, January and February. However, rainfall is sporadic and extent varies depending on the location in the country with up to 650 mm per annum in the north-east and as low as 250 mm per annum in the south-west. The average annual rainfall in Gaborone and the catchment area is approximately 500 mm (Department of Meteorological Services n.d).

Botswana's topography is fairly uniform, with few hills and only a slight undulation in the terrain. There are few areas of greater water accumulation such as lakes, existing ones having a large surface area but shallow depth resulting in high rates of evaporation (Moalafhi et al. 2012). There are only two perennial rivers in northern Botswana, each of which has its source in a different country. However, both rivers, the Okavango and the Chobe, are located in areas with low population density and high biodiversity with national parks being located in both areas and the Ramsar Convention, for conservation of wetlands, acting on the Okavango River. This means that there is limited extraction of water from both permanent resources (Scudder 2008). The majority of Botswana's two million inhabitants can be found on the countries eastern border, where soils are more suitable for agriculture and the drainage basin for the ephemeral Limpopo River can be found (Juana 2014).

Gaborone, initially the village of Gaberones, was chosen to replace Botswana’s previous capital Mafikeng, located across the border in South Africa, when the country gained independence from Great Britain in 1966. Besides wanting the capital city in the actual country, a variety of other factors influenced the location of Gaborone. Firstly, the village had no tribal affiliation meaning that there would be no tensions between neighbouring tribes and no risk of the new capital city encroaching on tribal land as it continued to develop (Nashua Telegraph 1966). Secondly, the proximity to the Notwane River with a basin suitable for dam construction served as a suitable means for providing the local residents with water (Geotechnical Instrumentation in Civil Engineering 1990).

At the time of the dam’s construction, it was estimated that the Gaborone Reservoir would be able to serve as a reliable freshwater source for the population of Gaborone which was estimated to increase from roughly 6’000 residents in 1966 to approximately 20’000 residents by 1983. However, this was an extreme underestimation as the population of Gaborone exceeded 50’000 by this time (Mosha 1996). In conjunction with this and in order to increase the capacity of the reservoir, the dam wall underwent further construction between 1984 and 1986, raising it an additional eight meters to a height of 25 meters (Andringa 1990). This increased the potential capacity from 38 million m<sup>3</sup> to 141.1 million m<sup>3</sup> (Water Utilities Corporation n.d). However, there have been few occasions where the water levels correspond with this maximum capacity and a prevalence of droughts since the wall was raised.

At the time of writing, Gaborone is currently experiencing an extended drought period which has been on-going since early 2011 (*Figure 3*). Water levels have fallen to the point where the ‘skeletons’ of Leadwood trees and cattle kraals’ that were found in the basin prior to the construction of the dam are starting to appear from the shallow water (*Figure 4*).



**Figure 3** Fluctuations in the volume of the Gaborone reservoir between 2005-2015. Measurements are all taken during the dry season between May and July (WUC, 2015).



**Figure 4** Photograph showing 'tree skeletons' taken in February 2015 from an island that emerged as the water levels continue to drop. Source: B. Farrington, 2015

## 5. Materials and Methods

Prior to trend determination, calculations and data visualisation, it was necessary to determine exactly what data would be required in order to best define what is impacting the decrease in reservoir volume. The volume of a water body (the change in reservoir storage  $\Delta S$ ) is dependent on three major factors: precipitation (P), runoff (R) and evapotranspiration (E), all of which make up the simplified water-balance (*I*) (Jensen 2010).

$$\Delta S = P + R - E \quad (1)$$

This report will focus on runoff in the catchment area and the climatic factors precipitation and evaporation, the latter of which requires temperatures data. Domestic consumption will also be researched as this the volume of water stored in the reservoir is also controlled by how much is abstracted for consumption purposes.

The aim of this study requires many different variables, including population statistics and meteorological data, each obtained from different fields of study. Much of the interpreted data come from monthly or annual measurements taken from a time series in order to see if there are any discernable trends.

### 5.1 Catchment Area

Firstly, it is important that the spatial extent and location of the catchment area is known. In order to solve this, a mosaic was created of four digital elevation model (DEM) tiles downloaded from the United States Geological Survey (USGS) satellite image database Earth Explorer. The DEM was produced in 2011 by the USGS and projected in WGS84 with a resolution of 30\*30 metres. Thereupon, the ArcMap programme was used to fill sinks, calculate both flow direction and flow accumulation and eventually the watershed of the area

(ESRI 2011). Both flow direction and flow accumulation are based on the elevation data in the DEM and are determined by algorithms. Water in a cell will flow towards the neighbouring cell of lowest elevation, thus making it possible to discern possible streams in areas with concentrated flow.

Finally, using a pour point on the Gaborone Dam wall, it was possible to calculate the watershed of the whole study area. An additional spatial analysis was performed whereby satellite images from Google Earth were carefully analysed visually with the purpose of detecting any additional dams within the Gaborone catchment area. Dams were found by searching for water bodies and reservoirs within the catchment and noting the coordinates at the location of each dam. The catchment areas for all the additional dams were visualised by using the same methods that resulted in the Gaborone catchment area. Calculating the extent of additional dams enables the visualisation of how much the Gaborone catchment area is reduced in size.

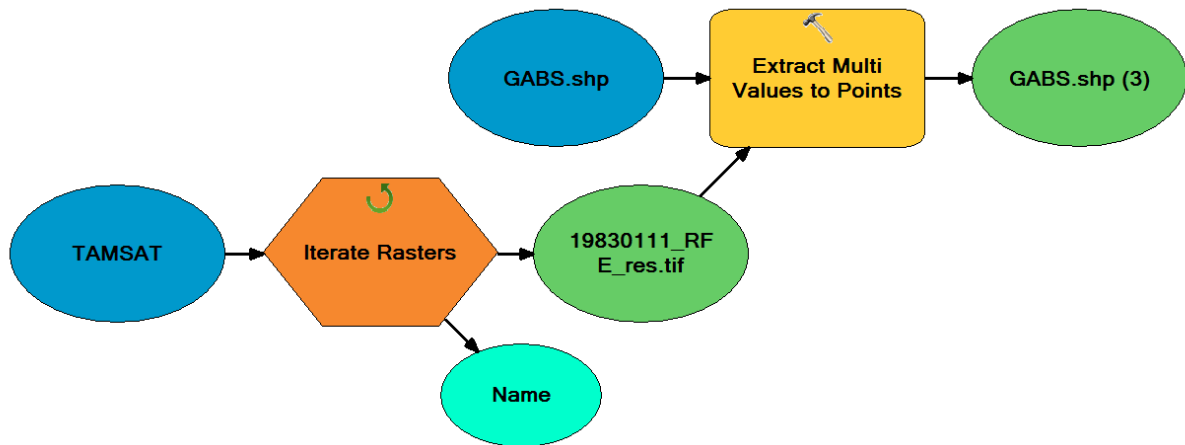
## **5.2 Climate**

The following sections describe the data and methods used for interpreting the climate variables rainfall, temperature and evaporation.

### **5.2.1 Rainfall**

All actual rainfall data have been acquired from the Botswana Department of Meteorological Services (DMS). The measurements were taken at the Sir Seretse Khama International Airport. As is the case with many countries, there is little to no access to reliable physical data measurements until very recent years or the coverage is limited and, as a result, the meteorology office must rely on a variety of methods to gain further insight of changes in the country's climate over the past century. The DMS provided a time series ranging from 1925 to 2010 of ground measurements. These were plotted and a regression analysis was performed. It is suggested that since the variable time is causally related to precipitation, it cannot fully explain any apparent trends (Andersson et al. 1983). Projections can only be made if one is relatively certain that the trend will continue. As rainfall is patchy and there are few rainfall gauges in the catchment area, the DMS also suggested using the monitoring product for Tropical Applications of Meteorology using Satellite data and ground observations (TAMSAT) for better coverage. TAMSAT was developed with the purpose of providing rainfall estimations over the African continent where ground measurements were few and far between. The data series runs from January 1983 until present, with ten-daily cumulative rainfall estimates for the 1<sup>st</sup>, 11<sup>th</sup> and 21<sup>st</sup> of each month (Tarnavsky et al. 2014). The result is a raster layer over the country in question. In order to determine the rainfall for Gaborone, a point shapefile named 'GABS.shp' was created locating the city, and the value for this point on the raster layer was extracted using the 'Extract Multi Values to Points' function within ArcMap. This was done for each TAMSAT raster layer, starting with the first on the 11<sup>th</sup> January 1983 (19830111\_RFE\_res.tiff in *Figure 5*). As there were over 1000 raster layers to be analysed, a model was created using the model builder function (*Figure 5*). An iterator was used in order to allow the model to loop and extract data from every TAMSAT raster. This proved to be a time efficient method of extracting cell values for precipitation over the catchment area. The result of the model was called GABS.shp (3), as

can be seen in *Figure 5*, and contained a table with three decades worth of ten-daily precipitation data.



**Figure 5** Model used to extract TAMSAT rainfall data (ESRI 2011)

### **5.2.2 Temperature**

As for data series regarding temperature trends over recent decades, the only reliable data that DMS were able to provide were the mean monthly maximum and minimum temperatures for the last three decades. These data played a major role in the calculation of evapotranspiration. Since only minimum and maximum temperature values were available from the DMS, data concerning temperature trends over a longer period had to be found elsewhere. Mean monthly temperature data was taken from the database DataGURU, developed at the Department of Physical Geography and Ecosystem Science at Lund University (Lund University n.d). The database provides interpolated climate data on a global scale between the years 1901 and 2011, though considering that the data is interpolated from ground data measurements, and the lack of available temperature from DMS, one must be weary of the accuracy of this data too. However, some data is better than none, and this available data was considered suitable. In the database, the spatial extent of the catchment area was manually set and a monthly mean temporal resolution was chosen from year 1901 until 2011. In order to analyse the data which was obtained in NetCDF format, it had to be run through a script in Matlab which allowed for the data to be opened in a database format such as Microsoft Excel (Microsoft 2010; MATLAB 2014). The changes in temperature were plotted graphically and a regression analysis was performed.

### **5.2.3 Evaporation**

Two methods for determining potential evaporation were tested. Firstly a simplified version of the Hargreaves-Samani equation, specific for when there is minimal climate data available, was tested (2) (Samani 2000).  $KT$  stands for the empirical coefficient which varies depending on whether the area of interest is located inland or on the coast. Gaborone is located inland, so the suggested value of 0.162 was used. The extra-terrestrial radiation,  $R_a$ , was obtained from the FAO (Allen et al. 1998).  $TD$  stands for minimum daily temperature subtracted from the maximum daily temperature whereby average monthly minimum and maximum values were used.  $TC$  stands for the average daily temperature.



$$ET_0 = 0.0135(KT)(R_a)(TD)^{0.5} (TC+17.8)$$

(2)

As the Hargreaves-Samani method uses minimal data another method used by the FAO that incorporates more climate variables such as humidity and wind speed was also tested.

The second evapotranspiration calculations followed the guidelines for computing the Penman-Monteith equation suggested by the FAO (Allen et al. 1998). The calculation intends to equate daily potential evaporation yet some data was only available on a monthly time scale and some, such as reliable wind speed and humidity measurements, were missing altogether. This meant that the method for calculating monthly potential evapotranspiration and the method for calculating potential evapotranspiration when data is missing had to be used in combination with one another. A detailed guideline of the method used can be found in *Appendix 1*. In order to account for the foreseeable global temperature increases projected in the International Panel for Climate Change (IPCC) AR5 report, potential evaporation was also calculated for a possible one, two, three and four degree Celsius increase in average monthly temperature that could occur in the near future.

### **5.3 Consumption**

Data regarding the changes in demography of the city were obtained through census reports and other official documents released by the Botswana Central Statistics Office (CSO) or Water Utilities Corporation (WUC), the parastatal organization concerned with water distribution and infrastructure in towns and cities in Botswana. Data regarding consumption was hard to come by, however the CSO had published total water consumption values for the years 1998 until 2008 (CSO (a) 2009). This data is a combination of domestic, government and commercial/industrial usage which comprise 34%, 47% and 19% of the Gaborone's total water consumption respectively. In order to determine the domestic consumption, 34% of the total consumption was calculated for each year that was represented. Additional data was obtained from reports by the World Bank that provided consumption figures for some years during the late seventies and early eighties (The World Bank 1983).

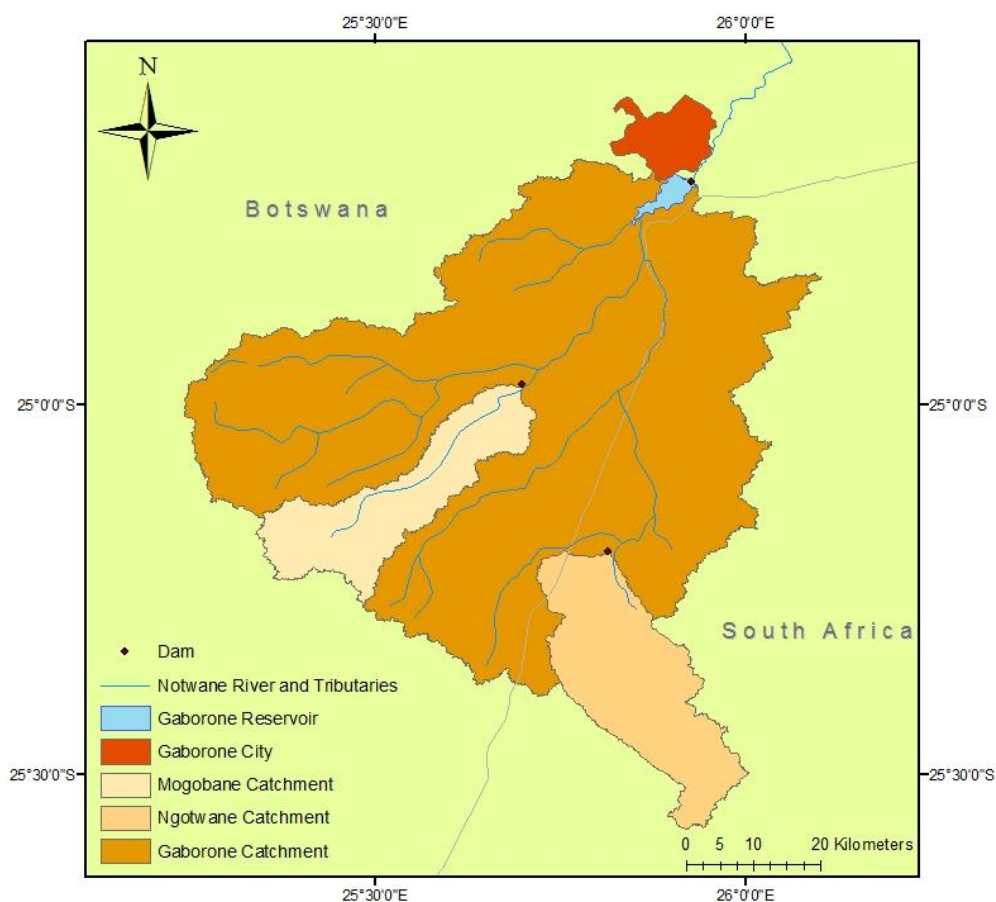
As there was no continuous time series, and more figures regarding long-term consumption were still of great interest, it was necessary to find another solution. To determine how the demand for water has changed, it is important to know how much water is required per person on a daily basis. In the water scarcity index, it is proposed that the minimum requirements of water necessary to satisfy the basic human needs in terms of sanitation and drinking water amongst other activities, is roughly 50 litres per person per day (Gleick 1996). With this value in mind, domestic consumption was estimated for those years with available population data for Gaborone (CSO (b) 2014).

## 6. Results

Despite restrictions regarding data availability, the following results show that changes in the variables of the water balance have all had some form of impact in regards to the water crisis in Gaborone though it is not yet possible to say which factor has the greatest effect.

### 6.1 Catchment Area

The extent of the Gaborone Reservoir catchment area as well as the catchment areas of the two larger reservoirs found within the Gaborone Reservoir catchment can be seen in *Figure 6*. Two thirds of the major catchment area exists in Botswana whilst the remaining catchment is found across the border in South Africa. The map also depicts the Notwane River and its tributaries, all of which are ephemeral streams that flow within the catchment area. Gaborone is located to the north of the watershed area but, despite high rates of development and urban expansion, still remains outside the catchment. The investigation of the two additional reservoirs (*Figure 6* and *Table 1*) shows that the smaller Mogobane Dam which is located between Gaborone and the town Lobatse occupies 9.36% of the total catchment area. The Ngotwane Dam, located in the South African part of the catchment is slightly larger and takes up 12.10% of the total catchment area. When these values are combined it results in the Gaborone Reservoir catchment being reduced by 21.46%.



**Figure 6** Map over the Gaborone catchment area including the Mogobane and Ngotwane catchment area. Projected Coordinate System: WGS\_1984\_UTM\_Zone\_35S

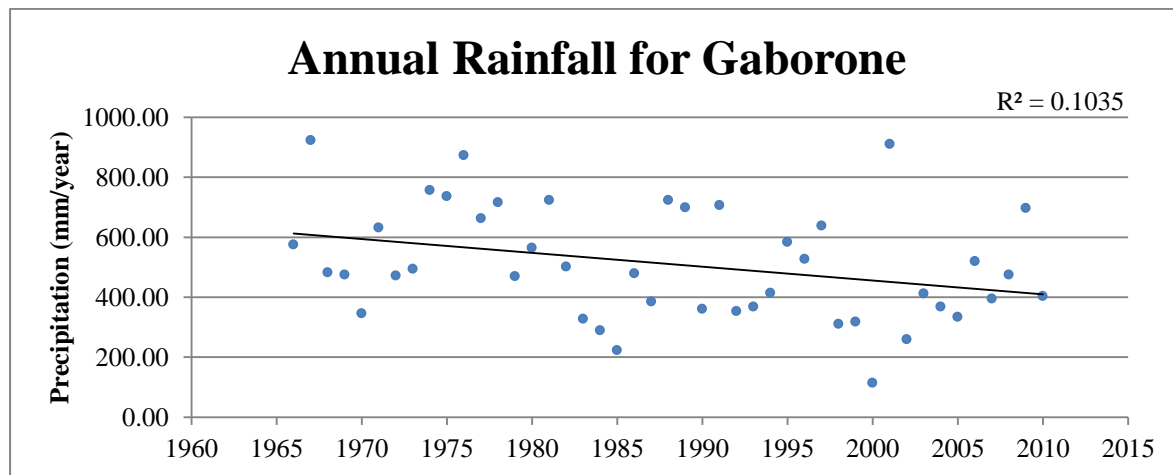
**Table 1** Areas of the respective watersheds

	Area (km <sup>2</sup> )	Percentage of Total Catchment (%)
<b>Mogobane Catchment</b>	418.28	9.36
<b>Ngotwane Catchment</b>	540.52	12.10
<b>Gaborone Catchment</b>	4468.19	100.00

## 6.2 Climate

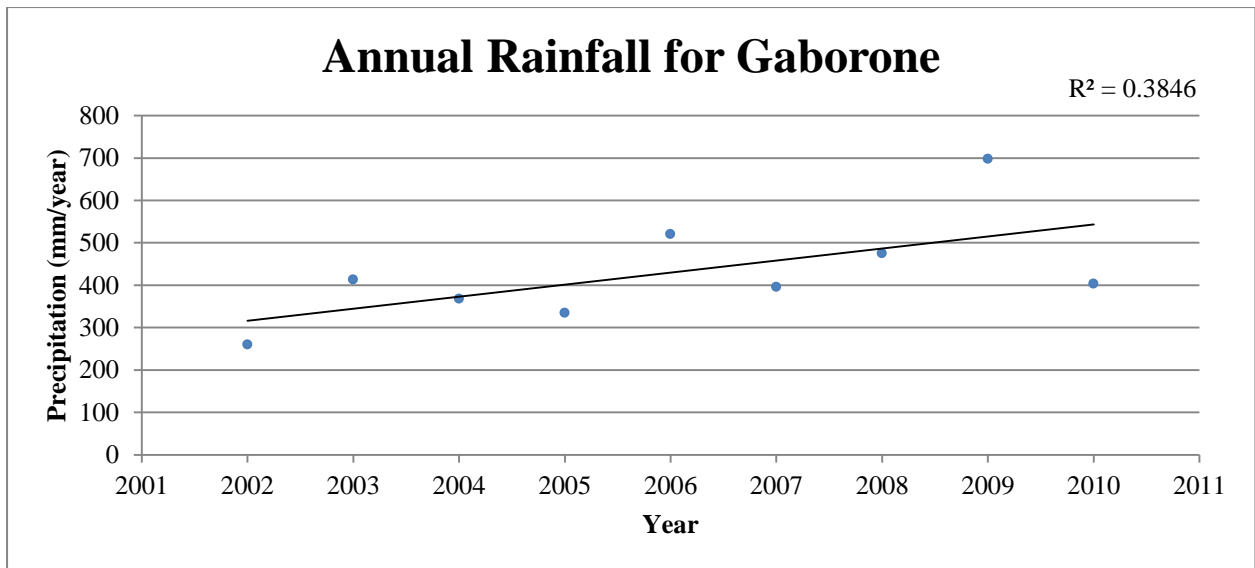
Concerning inputs into the area’s water balance, it is necessary to assess whether there have been any changes in precipitation. *Figure 7* below shows the total annual rainfall since the first year the reservoir was filled in 1965/66, until the year 2010<sup>1</sup>. The trend line makes it seem as if precipitation has decreased in the past five decades. However, the  $R^2$  value is only 0.1035 and a regression test with a confidence level of 95% confirms that the results of the regression are not statistically significant. A second annual rainfall figure (*Figure 8*) shows rainfall trends over the last decade where data was available. Though the  $R^2$  value is 0.3846, the value is not statistically significant when using a confidence level of 95%. The gradient of the fitted trend line suggest an increase in rainfall by 28 mm per year, though this value has no statistical significance either.

The TAMSAT rainfall estimates (*Figure 9*) provide insight on how rainfall was distributed during the past three decades and shows that there is a very distinctive wet and dry season each year. The dry seasons all show that there is little to no rainfall during this period. The graph also facilitates in showing periods of flood and drought. All the years that have a peak rainfall below 40 mm correspond with the recorded drought periods reported by the Ministry of Environment, Wildlife and Tourism (MEWT) (Manthe-Tsuaneng 2014). The graph also depicts the on-going drought period that commenced in 2011.

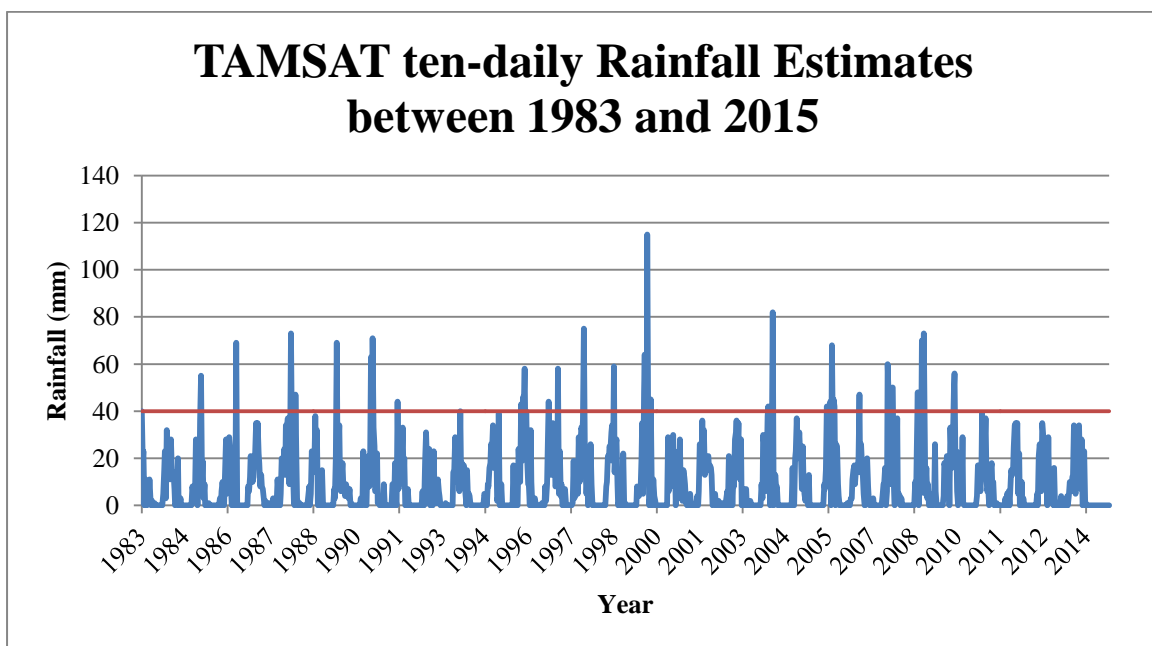


**Figure 7** Graph showing the total annual rainfall for Gaborone since the dam was first filled.

<sup>1</sup> The dam wall was raised between 1984-1986 increasing the potential capacity from 38 million m<sup>3</sup> to 141.1 million m<sup>3</sup>



**Figure 8** Annual rainfall for Gaborone over the last decade



**Figure 9** TAMSAT ten-daily rainfall estimates for Gaborone between 1983 and 2014

The mean monthly temperature for Gaborone has remained fairly consistent over the past 100 years, with temperatures ranging between 10 and 27 °C (*Figure 10*). Though the  $R^2$  value is very low, only 0.0071, a regression analysis with a confidence interval of 95% suggests that the ‘Significance f’ is below 0.05 (with a value of 0.0021) and is in fact significant. When looking at the gradient of the trend line, it suggests that temperatures will increase by roughly 0.001°C per year. However, if the time series is shortened and only the most recent decade is analysed (*Figure 11*), the results show that there is no statistically significant change in temperature.

Figure 12 shows the monthly potential evapotranspiration from calculations following the compendium in Appendix 1. The results from the Hargreaves equation were not included as they suggested annual evaporation to be over 4000 mm which is extremely high and was deemed unlikely. The levels of evapotranspiration are highest during the summer months which coincide with the rainy season, whilst lowest evapotranspiration levels are reached during the winter months and correspond with the dry season. Annual evaporation varies between an average of 3.00 mm/day in June and an average of 5.37 mm/day in December. The potential evaporation is plotted against the average rainfall to see the months where runoff is most probable.

If temperatures are to increase as the IPCC predicts and as the temperature graph suggests, this will have a direct impact on evaporation (Table 2). Evaporation increases with an average of 0.68% per every degree Celsius increase in temperature.

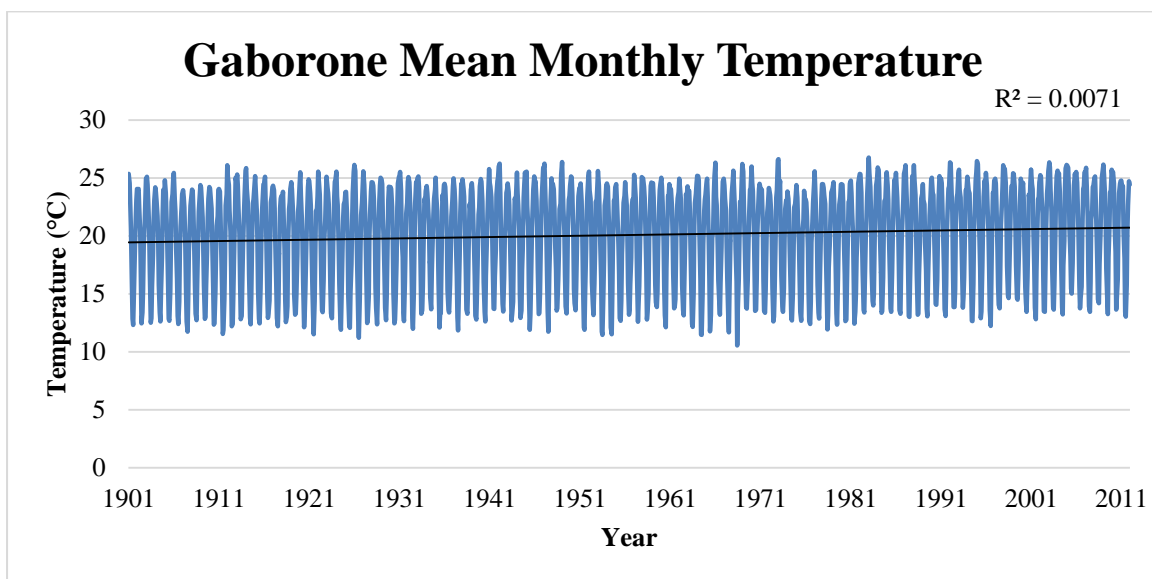


Figure 10 The trend line shows that temperature in Gaborone has increased by 1°C between 1901 and 2011(Lund University n.d)

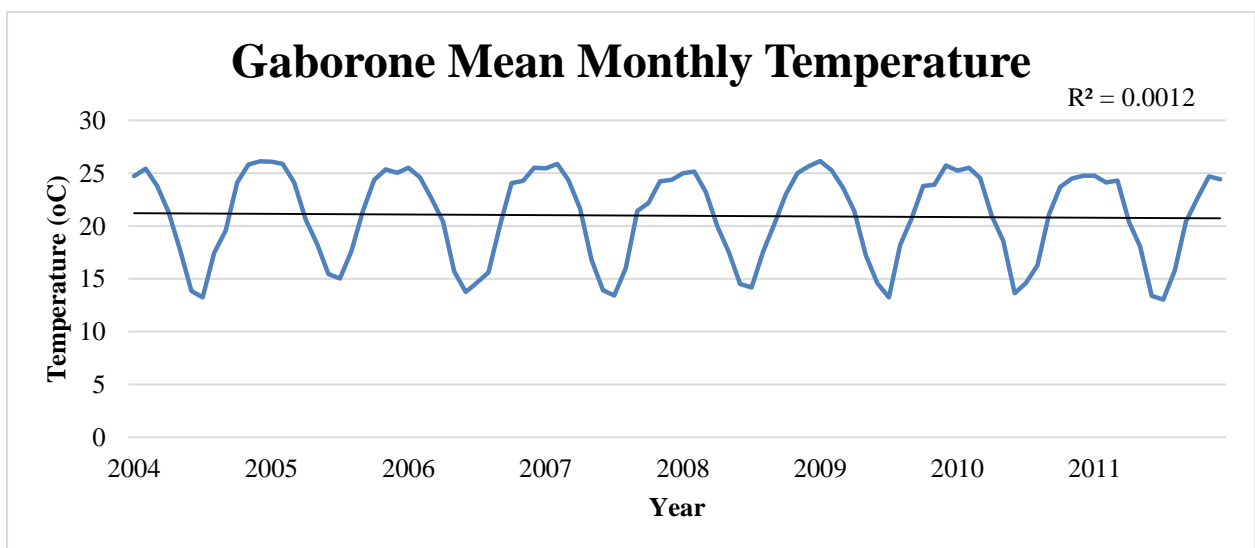
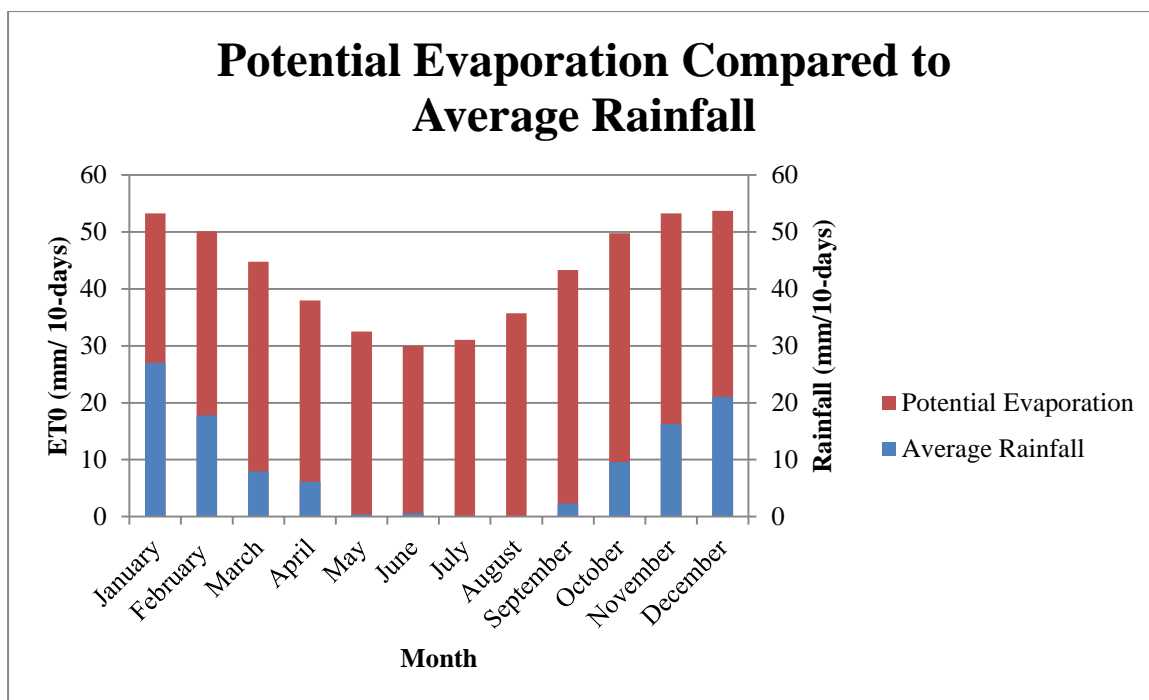


Figure 11 Mean monthly temperature over the last decade



**Figure 12** Potential evaporation for 10-daily measurements of rainfall

**Table 2** Percentage change in evaporation as temperature increases

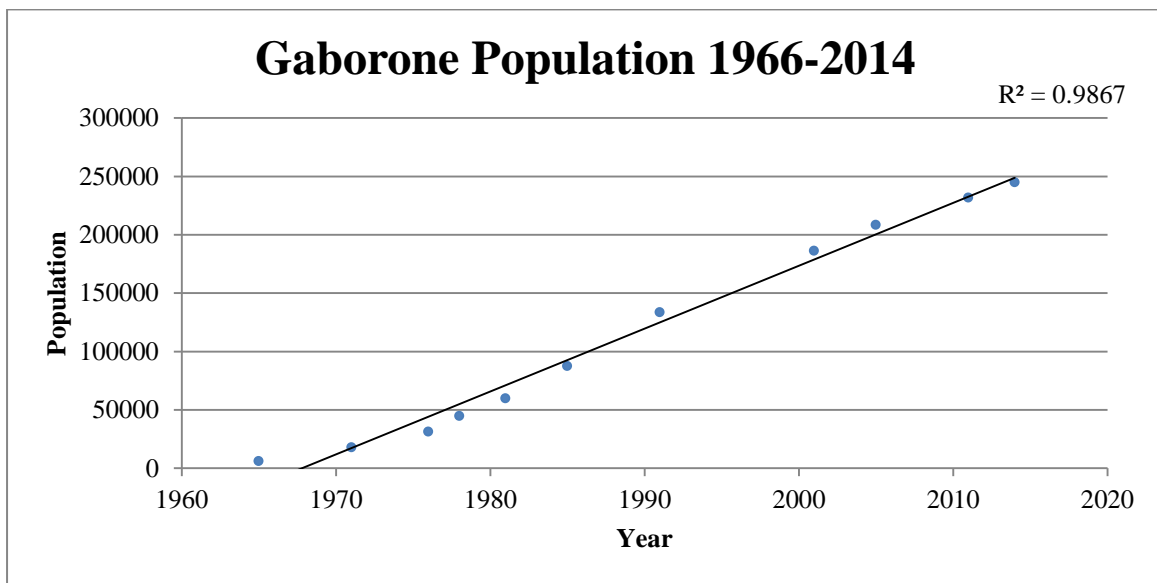
Mean temperature increase (°C)	1	2	3	4
Average ET <sub>0</sub> change per degree increase (%)	0.57	1.21	1.93	2.71

### 6.3 Consumption

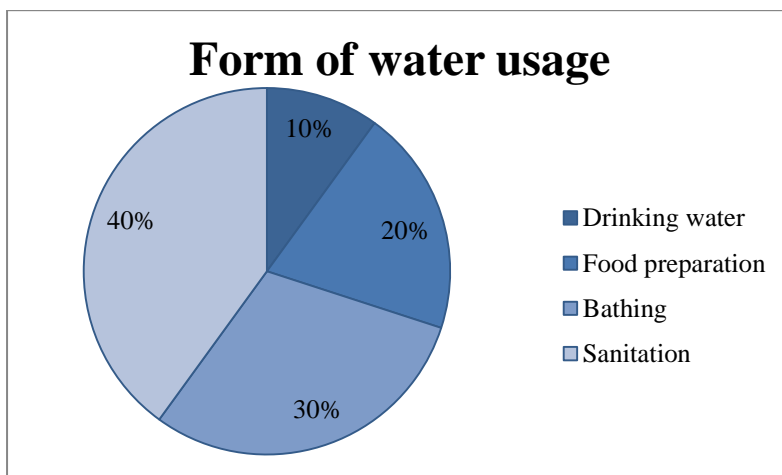
Since independence in 1966, Gaborone’s population has steadily increased in a linear fashion to roughly 40 times what it was at the city’s conception (*Figure 13*). This population growth rate is predicted to continue, with projections suggesting that the number of inhabitants in Gaborone will have surpassed 300’000 by 2030 (Sebekedi n.d). As water is vital for survival, each new inhabitant will require some form of water supply in order to prosper. It is suggested that the minimum water requirement is 50 litres per person per day in the proportions suggested in *Figure 14* (Gleick 1996). *Figure 15* shows a combination of domestic consumption estimations, calculated by multiplying the total population with the minimum water requirement since 1966, and actual domestic water consumption. As the consumption estimations are based directly on population growth, these results, shown in *Figure 15*, follow the same positive linear gradient as the population growth in *Figure 13*. The actual consumption values also follow a pattern of increasing water demand though with greater variability (see *Figure 15* and *Figure 16*).

Firstly, there is very little historical data regarding consumption, so it is not possible to see exactly how consumption has changed since the reservoir first started acting as the city’s leading water supplier. The available data shows domestic consumption patterns between 1978 and 1982, and 1998 and 2008. Despite being an unfortunately short time series, it is still possible to discern a positive trend in the results. There are clear fluctuations in the levels of consumption. This can be seen clearly by the distinct drop in consumption from 8.33 Mm<sup>3</sup> to

6.68 Mm<sup>3</sup> between 2004 and 2005. However, by 2007 the values return to what they were prior to the sudden 1.66 Mm<sup>3</sup> decrease in consumption. The actual consumption from 1978 is the year that corresponds best with the estimated values but apart from that actual recorded consumption is greater than consumption estimated from minimum requirements. *Figure 16* shows a similar pattern but of how the average daily consumption for each year has changed over time. Similar to *Figure 15*, it shows that actual consumption is greater than the recommended minimum and, by year 1998, the daily consumption is almost double the minimum recommendation. A regression analysis with a confidence interval of 95% was performed on the daily consumption data (*Figure 16*) which showed that there was no statistically significant change in the domestic consumption of water in Gaborone between 1998 and 2008.



**Figure 13** The change in Gaborone’s population since independence in 1966 (CSO (b) 2014)



**Figure 14** The proportions in which the 50litre/day water minimum is used (Gleick 1996).

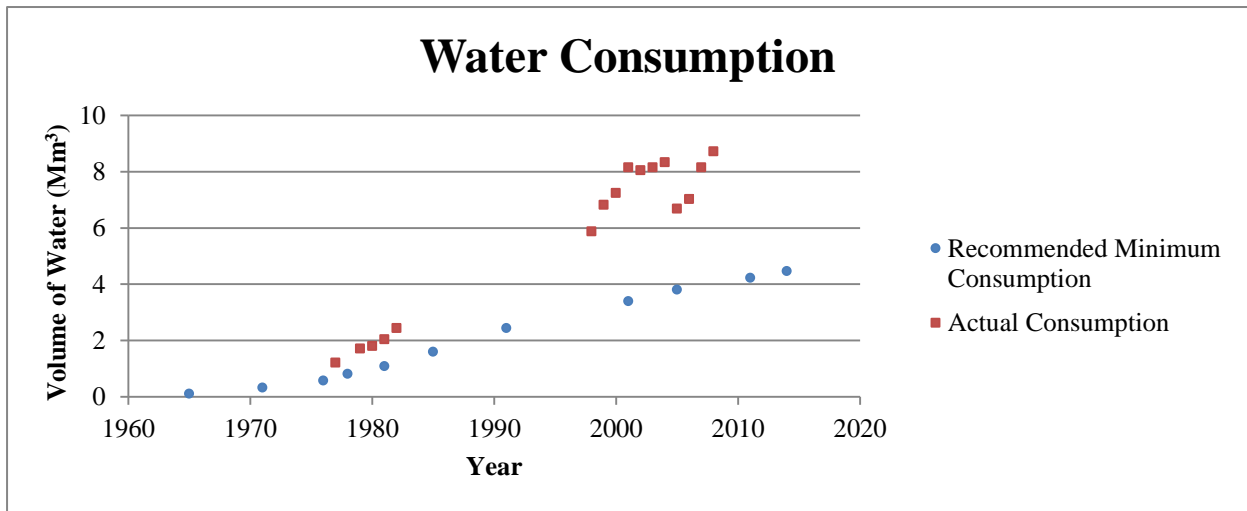


Figure 15 Changing patterns of water consumption in Gaborone (CSO (a) 2009).

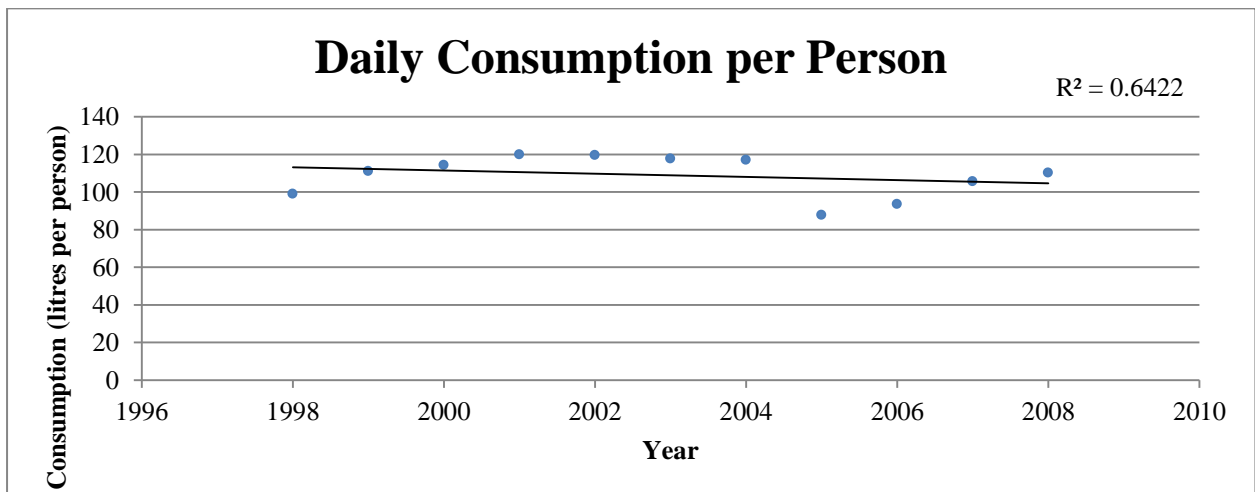


Figure 16 Change in daily consumption per person (CSO (a) 2009).

## 7. Discussion

The following discussion is divided into subsections whereby discussion regarding the results of the study will be interpreted separately, as well as a discussion regarding the future of water supply to Gaborone and lastly the sources of error and possible methods for improving the report.

### 7.1 Catchment Area

The purpose of mapping the catchment area of the dams is to see, in spatial terms, the area of land where precipitation can fall that will eventually accumulate in the same point at a lower elevation. A larger surface area means that it is possible to accumulate more water, but when additional dams are built within an existing catchment area it decreases the affectivity of the catchment as water must first fill the upstream reservoirs before being able to continue. According to a study by Meigh (1995), approximately 25% of Gaborone’s catchment area is



cut off as a result of 203 smaller upstream dams and reservoirs. The report did not provide the location of these dams, so it was not possible to find out whether they were still in place or if more had been constructed, and the sizes of their catchment areas. When performing the spatial analysis, only the Mogobane Dam and the Ngotwane Dam were discernable, reducing the catchment by 21.46%. The Ngotwane Dam was completed in 1982, so one can say that its construction has led to a reduction of the catchment area (Siderius 1971). It is unclear when the Mogobane Dam was completed as there are no published dates available. If it was completed after the construction of the Gaborone Dam, then it too is restricting the size of the catchment area. However, if the Mogobane Dam was constructed before the Gaborone Dam was completed; it means that the Mogobane catchment area was never actually a part of the Gaborone catchment area. Without additional data regarding additional dams within the catchment area, it is not possible to say how great an impact the supposedly remaining 201 dams account for.

The foremost purpose of the Mogobane and Ngotwane dams is for irrigation (Siderius 1971). Many of these smaller dams are built by subsistence farmers in order to water their livestock, and in some cases for small scale irrigation. Despite this additional consumption, it is believed that evaporation from the additional reservoirs throughout the catchment area causes greater water loss (Meigh 1995). In fact, fewer larger reservoirs are said to cause less water loss in comparison to many smaller reservoirs of the same capacity, as they tend to have a smaller surface area in relation to their capacity, which reduces evaporation losses (Acreman et al. 2009).

## **7.2 Climate**

The latest IPCC report predicts many probable changes that are likely to have an impact on the climate of southern Africa, including Botswana. However, the results in this study show no statistical significance for the majority of the climate data, so no solid conclusions can be drawn.

The results from *Figure 7* and *8* are not statistically significant and cannot aid in predicting whether or not the next year will be a flooding year or a drought year. There is high variability in the measurements with the regression analysis only accounting for approximately 10% of the variance for *Figure 7*. A clear example of this would be a comparison between the year 2000 and 2001 where the former only received 114.7 mm of rainfall but the following year precipitation levels exceeded 900 mm.

The TAMSAT results (*Figure 9*) shows no clear visual trends regarding precipitation intensity (mm/ 10 days) and distribution during the 30 year time scale that the data was available for. Though intensity has been decreasing since 2008, this does not suggest that this pattern will continue into the upcoming rainy season and there is always a chance that the rains will return. There are predictions by the IPCC suggesting that rainfall will occur later into the wet season and rainfall will become more intense as the season comes to an end (Christensen et al. 2013). It can be said with confidence that soil moisture will decrease in the years to come (Collins et al. 2013). Research shows that the moisture gradient of the soil has the ability to prompt convective systems, so if a decrease in soil moisture is inevitable, this

will have negative consequences for local rainfall for both quantity and distribution (Christensen et al. 2013). A decrease in the total rainfall, essentially reducing the total inputs into the water balance, will cause a decrease in the total runoff. Similarly, if the intensity of the rainstorms decrease, meaning that the same amount of rain falls over a longer time period, then it is more likely that rain will infiltrate to the groundwater as opposed to accumulating as surface water.

The results in *Table 2* show that potential evapotranspiration will increase if temperatures continue to rise as is possible according to the statistical analysis performed on *Figure 10*. The IPCC project that there will be a decrease in evaporation in the years to come as there will be less water available to evaporate (Kirtman et al. 2013). *Figure 12* shows that evapotranspiration levels do vary throughout the average year, with lower levels during the dry season and increased evaporation during the rainy season. The shape of the graph mimics that of radiation levels, temperature and precipitation for the average year, with lowest values being recorded during the austral winter and highest values vice versa. Reasons for this similarity could be due to the fact that the FAO evapotranspiration is strongly based on temperature data as well as changes in radiation. The monthly evaporation values are not necessarily representative for every day of each respective month. When rainfall occurs, it is often in intense, sporadic storms lasting up to four days whilst the remainder of the month receives little to no rainfall. Evaporation is only possible when there is water available to evaporate. If there is little surface water in the region then evaporation rates may be lower than what is suggested in *Figure 12*. Since all the evaporation values exceed the rainfall values it emphasises the need for higher resolution data as the figure suggests that all resultant precipitation would be evaporated creating no runoff.

The average percentage change in evaporation will increase with every increase in degree Celsius according to *Table 2*. This outcome seems viable considering that a system requires energy for evaporation to occur, and increasing the average temperature acts as the increase in the energy input. This does not mean to say that temperature is the only factor influencing this increase. As data for radiation trends was unavailable, it is not possible to see how changes in radiation would affect the evaporation rates. However, this only shows an increase in potential evaporation. Actual evaporation is unlikely to increase if there is no water available to evaporate.

### **7.3 Consumption**

A growing population entails an increase in pressure on water resources, since available reservoirs and reserves are forced to provide for more people. As the population of the city has increased over the past decades and continues to increase as it is predicted to in the future, there will be an increase in water consumption even if people are limited to the minimum requirement of 50 litres. Moreover, *Figure 15* and *Figure 16* only present figures for domestic consumption. This means that water used for industry, commerce and the development of the small village into a bustling city are not accounted for. In reality, domestic consumption represents only one third of the total water usage in Gaborone. The remaining 66% is used for government purposes (which includes water for ministry buildings) (47%) and for commerce and industry (19%) as suggested by the Central Statistics

Office (2009). The pie diagram in *Figure 14* shows the proportions of water usage suggested by Gleick (1996). These are only estimations, and it is very likely that water in Gaborone is used differently, for example the watering of livestock. Water usage in sanitation differs depending on whether residents use pit latrines or flush toilets, with flush toilets requiring more water than the former (Gleick 1996).

The results in *Figure 15* show a visible difference between the recommended minimum consumption and the actual consumption in the city, with actual consumption for the majority of the years using an excess of two million m<sup>3</sup>. It is clear that the 50 litre consumption minimum suggested by Gleick (*Figure 14*) does not accurately reflect the consumption habits of a rapidly developing country and this is further emphasised in *Figure 16* which shows that the latest daily consumption values are more than double what is suggested as the minimum. Botswana's economy has experienced the world's highest growth rate since 1965 of roughly 7.7% between 1965 and 1998 as a result of the prospering diamond industry (Acemoglu et al. 2002; Van der Ploeg 2011). This wealth has allowed for improvements regarding accessibility to piped water, predominantly in urban areas. Access to piped water has increased from 56% in 1981 to 77% in 1991 to 83% in 1999, with remainder of urban dwellers having access to a communal standpipe for water provision (Lado 1997; Goldblatt et al. 1999). When accessibility ceases to be a major problem, the likelihood of wasteful consumption occurring increases as there is no longer the hassle of having to physically transport water from its source to one's home. As the nation's wealth has increased, so has the demand for luxuries such as flush toilets as opposed to the less water intensive pit latrines, cars and swimming pools, the latter of which are not accounted for in Gleick's minimum water requirement model (*Figure 14*). This means, that daily consumption may continue to increase as the city continues to develop.

#### **7.4 Planning for the Future**

The Government of Botswana has been anticipating water shortages throughout the entire country for the last two decades and has thus already commenced management strategies in order to provide the countries citizens and industries with plentiful and reliable water sources (Department of Environmental Affairs 2006).

The North-South Carrier Water Project (NSCWP) was proposed in 1992 by the National Water Master Plan (Elmi Mohamed 2014). The purpose of the project is to reduce the strain placed on the Gaborone Reservoir by obtaining water from other reservoirs and pumping the water through a pipeline to Gaborone. The project, divided into Phase I and Phase II, intends to construct a pipeline that will pump water from newly constructed reservoirs in eastern Botswana near Francistown (*Figure 2*), southwards to Gaborone and the towns and villages it passes along the way (Bevanger 1994). Phase I was completed in 1999 and involved the construction of the Letsibogo and Shashe dams on tributaries of the Limpopo River, the catchment of which covers parts of Botswana, Mozambique, South Africa and Zimbabwe. The importation of water from the Molatedi Dam in South Africa was also part of the first phase of NSCWP (van Zyl 2012). Phase II of the NSCWP which has yet to be completed, involves the construction of the Dikgatlong Dam (which was completed in 2011) near the Botswana-Zimbabwe border and the necessary pipes needed to connect it to the North-South

Carrier (Lindhe et al. 2014). A covered reservoir has been built 15 kilometres outside of Gaborone which will allow for water storage whilst reducing surface evaporation (Bevanger 1994). Not only should the pipeline provide water for Botswana's increasing domestic demand, the NSCWP is intended to provide water to mines and power stations the pipeline passes along the way. Despite this promising outlook, the project is time consuming and there are often malfunctions within the pipeline often due to electricity shortages and power outages. Reports suggest that 46% of the water that flows in the NSC pipeline is being lost through leakages (OECD 2007). Additional construction and structural repairs of the NSC pipeline are still taking place in 2015, and it has not yet reached its full potential.

Gaborone has been noticeably experiencing the consequences of water scarcity over the past decade. Periods of water restrictions have been reoccurring but have, as of November 2012, been firmly in place and strictly enforced by WUC. This entails regulations against using potable water for watering gardens and recreational areas, filling swimming pools and the use of hosepipes. As of 2015, WUC has been unable to pump any water from the reservoir, making Gaborone completely reliant on external sources such as the NSC pipeline and imports from South Africa. However, there are often cases of decreased water pressure and on occasion the complete cutting-off of the water supply in certain parts of the city leaving people without water for up to days on end. The current water situation suggests that it is necessary that the water rationing continue. It will be important to integrate the importance of water into the education system so as to teach future generations the importance of sustainable water use.

Regarding development, the economy of Gaborone, and essentially the nation, will be impacted by continuing water shortages. Water is not only used for domestic consumption, but also in industry, commerce and for government purposes (CSO (a) 2009). The Kgalagadi Breweries (Pty) Ltd (KBL) are the leading producers of beer and fizzy drinks in Botswana. Based in Gaborone, the water intensive industry is actively trying to reduce their consumption of water in the production process, the goal being to reduce water usage by 25% between 2008 and 2015 in the production of clear beers (SBHL 2011). It is possible that with further years of water restrictions and the unrepaired flaws in the NSC pipeline that it may be necessary for KBL amongst other industries to relocate to regions with a more reliable water supply. This will be at the cost of Gaborone locals' jobs.

As the results clearly show the spatial extent that the Mogobane and Ngotwane dams cover in the Gaborone catchment area, it is vital that further research into the impacts of additional dams within catchment areas takes place. This will aid in determining to what magnitude additional smaller dams within a catchment area impact the runoff into major reservoirs. The Mogobane and Ngotwane are official dams but it is believed that there are indeed additional smaller, illegal dams within the Gaborone catchment. If it is shown that these dams strongly impact the ability for runoff, then it will be essential that the government and water officials increase efforts in limiting the presence of these dams. It is advisable that the existing legal dams increase the amount of water released from the dams so that it is allowed to continue flowing towards the Gaborone reservoir.

Other possible solutions to help decrease water scarcity would be to recycle water, in particular that from sewage, and treat it to a level where it is once again suitable for consumption. At present a small portion of wastewater is being recycled and used in irrigation and as of 2013 no recycled water had been treated for consumption. The government of Botswana intends to recycle up to 96% of all waste water by the year 2030 (Colman 2013). Water saving devices should also be promoted and water awareness should be included in school curricula. Lastly, not for Gaborone city but for the nation as a whole, it has been proposed that since Botswana has a very large proportion of livestock, farmers should be encouraged to invest in goats as opposed to cattle as they are less water intensive (Department of Environmental Affairs 2006).

## **8. Sources of Error and Suggestions for Improvement**

Though conclusions can still be drawn from the acquired results, additional data would be necessary if more concrete conclusions are to be made. Such data would include release of water from upstream dams as well as values for how much rainfall is required in order to produce runoff. The following sections provide recommendations of ways to amend the difficulties encountered throughout the study.

### **8.1 Catchment Area**

The flow accumulation algorithm within the ArcMap programme used to compute the watershed of the area was of the one directional single flow variety. This means that when the model is being run, the contents of a cell would flow into the deepest neighbouring cell. Though this method does produce correct results, a multiple directional flow algorithm exists that transfers cell contents to neighbouring cells of lower elevations in a weighted manner (Schäuble et al. 2008; Pilesjö and Hasan 2014). This method may improve results as Botswana's topography is fairly uniform.

Secondly, the locations of the additional dams within the catchment area were found by analysing aerial photographs and satellite images found on Google Earth. Owing to their size, the Mogobane Dam and the Ngotwane Dam were able to be identified. Other dams were either too small or contained no water making them impossible to discern and as a result they were unable to be mapped and they did not have their catchment area accounted for. If satellite images from a known wet period were available, it would make dam identification easier. Another method, though much more time consuming and expensive would be to complete a field study and note each dam's location physically using a GPS. It is also possible to identify smaller dams using a DEM. This entails analysing sinks either by size or by volume as dams will create a sink behind them.

Finally, the last report to publish the predicted number of smaller dams within the catchment area was published by Meigh in 1995. Newspaper articles state that WUC has written a report regarding additional dams within the catchment area but that it is not intended on being published for the benefit of the public, so it is uncertain whether this value has changed at all over the past 20 years.

## **8.2 Climate**

Firstly, it is not certain how many weather stations or ground measurement points that the TAMSAT data is based on. The maximum and minimum values came from the same location at the Sir Seretse Khama International Airport, so it is highly possible that the TAMSAT measurements are taken from the same place. Though it is not possible to take new ground measurements for previous years, it is advised that the DMS continue to take several measurements in various locations in Gaborone to give the most accurate results. Due to poor resolution of data, a 30 year timespan of 10-daily data being the highest resolution available, it was not possible to determine the intensity of the rain showers. If the same volume of rain fell in a two hour period or over a span of ten days, the former would generate much greater runoff. It is suggested that higher resolution data, daily or preferably hourly readings, be taken in order to achieve more accurate runoff estimations as this is not possible with monthly data.

In order to calculate evaporation, it was necessary to combine two techniques used by the FAO to obtain potential monthly evaporation. Restricted data availability regarding wind speed and vapour pressure as well as only having access to monthly maximum and minimum temperatures meant that daily evaporation was unable to be calculated. With daily evaporation it would have been possible to determine how much rain water is available for runoff after evaporation has occurred. Though we are able to conclude that evaporation will increase, it is still uncertain how big of a roll this factor plays in the drying of the Gaborone reservoir.

## **8.3 Consumption**

The only problem encountered regarding the investigation of the consumption trends was the inconsistency in terms of their distribution along the time scale. There were no public databases where the data could be downloaded, so all the analysed data was acquired through examining census reports or similar government documents. Population census' are decadal, and it was troublesome finding trustworthy data sources for the year's in-between. When data was found for these years, it was often concerning the entire countries population as opposed to Gaborone's. Similar problems were faced when trying to obtain consumption data

## **9. Conclusions**

Due to data limitations, no statistically concrete results can be drawn from this report. The catchment area, climate and consumption all impact how much water is able to be accumulated in the Gaborone Reservoir; yet poor data resolution makes it impossible to rank the factors in order of impact intensity. The only statistically significant results were those for temperature increase since 1901. However, when focussing on the last ten years, there is no statistically significant change in temperature, rainfall or consumption. As the Ngotwane Dam was completed 20 years after the Gaborone Dam, it is certain that its presence restricts the Gaborone catchment by 12.1%. As the year of completion for the Mogobane Dam is uncertain, it is still unclear as to whether it too is restricting the Gaborone catchment, or whether it was present before the Gaborone Dam was completed.

Though it is not possible to control when, where or even if precipitation will fall, it is possible to ensure that authorities take a stand in removing any unauthorised dams within the catchment area. The impacts of consumption can also be reduced by providing access to alternative water supplies such as the NSC pipeline and by promoting water awareness and water saving devices. Evaporation is less likely to cause as great an impact, as lack of water impedes the evaporation process, though if there is an increase in rainfall, it is possible that actual evaporation will show similarities towards the potential evaporation values.

The decision to select Gaborone as the capital of Botswana may not have been the wisest decision from a water perspective as the Notwane River was already known to be unreliable during drier periods. If rainfall, evaporation and consumption are to continue following their current trends, then it is essential that experts from a spectrum of disciplines ranging from technology and engineering to politics and policy, work in symbiosis. Phase II of the NSCWP must keep to its original timeframe and the current faults must be fixed as soon as possible to allow people and companies in Gaborone to continue to prosper. Education is necessary for promoting water conservation throughout the city and good communication between water authorities and consumers is important in order to keep everyone informed of what is going on. As we say in Botswana, PULA! Let there be rain.

## 10. Bibliography

- Abebe, D. 2014. Egypt, Ethiopia, and the Nile: The Economics of International Water Law. *Chicago Journal of International Law*, 15.
- Acemoglu, D., S. Johnson, and J. A. Robinson. 2002. An african success story: Botswana.
- Acreman, M., R. Harding, C. Sullivan, C. Stratford, F. Farquharson, G. Rees, H. Houghton-Carr, I. Gale, et al. 2009. Review of hydrological issues on water storage in international development.
- Allen, R. G., L. S. Pereira, D. Raes, and M. Smith. 1998. Crop evapotranspiration-Guidelines for computing crop water requirements-FAO Irrigation and drainage paper 56. *FAO, Rome*, 300.
- Andersson, G., U. Jorner, and A. Ågren. 1983. *Regressions- och tidsserieanalyser med och utan datorstöd*. Lund, Sweden: Studentlitteratur.
- Andringa, J. 1990. Water Temperatures of a Shallow Reservoir in Botswana. *Botswana Notes and Records*: 57-63.
- Bevanger, K. 1994. The North-South Carrier Water Project in Botswana. A review of environmental impact assessments. *NINA Oppdragsmelding 320*: 1-25.
- Christensen, J. H., K. Krishna Kumar, E. Aldrian, S.-I. An, I. F. A. Cavalcanti, M. de Castro, W. Dong, P. Goswami, et al. 2013. Climate Phenomena and their Relevance for Future Regional Climate Change. In *Climate Change 2013: The Physical Science Basis. Contribution of Working Group I to the Fifth Assessment Report of the Intergovernmental Panel on Climate Change*, eds. T. F. Stocker, D. Qin, G.-K. Plattner, M. Tignor, S. K. Allen, J. Boschung, A. Nauels, Y. Xia, V. Bex, and P. M. Midgley, 1217–1308. Cambridge, United Kingdom and New York, NY, USA: Cambridge University Press.
- Collins, M., R. Knutti, J. Arblaster, J.-L. Dufresne, T. Fichet, P. Friedlingstein, X. Gao, W. J. Gutowski, et al. 2013. Long-term Climate Change: Projections, Commitments and Irreversibility. In *Climate Change 2013: The Physical Science Basis. Contribution of Working Group I to the Fifth Assessment Report of the Intergovernmental Panel on Climate Change*, eds. T. F. Stocker, D. Qin, G.-K. Plattner, M. Tignor, S. K. Allen, J. Boschung, A. Nauels, Y. Xia, V. Bex, and P. M. Midgley, 1029–1136. Cambridge, United Kingdom and New York, NY, USA: Cambridge University Press.

- Colman, A. J. 2013. The Political Economy and Coalitions in Botswana's Water Sector Reform 2009-13: to what extent can the process of reform be understood? PhD Thesis University of East Anglia
- CSO (a), 2009. Botswana Water Statistics. Report, Gaborone, Botswana. [in Swedish, English summary]
- CSO (b). 2014. *Population and housing census 2011- Analytical Report*. Gaborone, Botswana: Statistics Botswana.
- Denbow, J. R., and P. C. Thebe. 2006. *Culture and customs of Botswana*. Greenwood Publishing Group.
- Department of Environmental Affairs. 2006. Water Accounts of Botswana 1992-2003. ed. D. o. E. Affairs. Gaborone, Botswana.
- Department of Meteorological Services. n.d. Botswana Climate. Retrieved 20 April 2015, from [http://www.mewt.gov.bw/DMS/article.php?id\\_mnu=91](http://www.mewt.gov.bw/DMS/article.php?id_mnu=91).
- Du Plessis, A. J. E., and K. M. Rowntree. 2003. WATER RESOURCES IN BOTSWANA WITH PARTICULAR REFERENCE TO THE SAVANNA REGIONS. *South African Geographical Journal*, 85: 42-49. DOI: 10.1080/03736245.2003.9713783
- Eckardt, N. A., E. Cominelli, M. Galbiati, and C. Tonelli. 2009. The future of science: food and water for life. *The Plant cell*, 21: 368-372. DOI: 10.1105/tpc.109.066209
- Elmi Mohamed, A. 2014. Sharing Water in Africa: Comparative Analysis of the Limpopo and Orange-Senqu River Basins in SADC and the Juba and Shabelle River Basins in the Horn of Africa. ArcGIS Desktop: Release 10. Environmental Systems Research Institute, Redlands, CA.
- Geotechnical Instrumentation in Civil Engineering. 1990. *Geotechnical instrumentation in practice : Purpose, performance and interpretation*. Thomas Telford, 1990.
- Gewald, J. B. 2001. El Negro, El Nino, witchcraft and the absence of rain in Botswana. *African affairs*, 100: 555-580.
- Gleick, P. H. 1996. Basic water requirements for human activities: Meeting basic needs. *Water International*, 21: 83-92.
- Goldblatt, M., J. Ndamba, B. van der Merwe, F. Gomes, B. Haasb-roek, and A. J. 1999. Water Demand Management: towards developing effective strategies for Southern Africa. *IUCN*.
- Hammond, M. 2013. The Grand Ethiopian Renaissance Dam and the Blue Nile: Implications for transboundary water governance. In *Global Water Forum*.
- Jensen, M. E. 2010. Estimating evaporation from water surfaces. In *CSU/ARS Evapotranspiration Workshop*, 1-27.
- Juana, J. S., 2014. Aid and the environment: The case of Botswana. WIDER Working Paper, Report. [in Swedish, English summary]
- Khama, I. 2013. State of the Nation Address. *Government of Botswana*.
- Kirtman, B., S. B. Power, J. A. Adedoyin, G. J. Boer, R. Bojariu, I. Camilloni, F. J. Doblas-Reyes, A. M. Fiore, et al. 2013. Near-term Climate Change: Projections and Predictability. In *Climate Change 2013: The Physical Science Basis. Contribution of Working Group I to the Fifth Assessment Report of the Intergovernmental Panel on Climate Change*, eds. T. F. Stocker, D. Qin, G.-K. Plattner, M. Tignor, S. K. Allen, J. Boschung, A. Nauels, Y. Xia, V. Bex, and P. M. Midgley, 953–1028. Cambridge, United Kingdom and New York, NY, USA: Cambridge University Press.
- Lado, C. 1997. Socio-economic factors influencing sustainable water supply in Botswana. *GeoJournal*, 41: 43-53.
- Lee, R. 2011. The Outlook for Population Growth. *Science*, 333: 569-573. DOI: 10.1126/science.1208859
- Lindhe, A., L. Rosén, P.-O. Johansson, and T. Norberg. 2014. Increase of Water Supply Safety by Managed Aquifer Recharge along the North-South Carrier—A pre-feasibility study. *Department of Civil and Environmental Engineering, Chalmers University of Technology*, 2014:2.



- DataGURU. Lund University Faculty of Science, Lund, Sweden.
- Madulu, N. F. 2003. Linking poverty levels to water resource use and conflicts in rural Tanzania. *Physics and Chemistry of the Earth, Parts A/B/C*, 28: 911-917. DOI: <http://dx.doi.org/10.1016/j.pce.2003.08.024>
- Manthe-Tsuaneng, M. 2014. Drought Conditions and Management Strategies in Botswana. Gaborone, Botswana.
- MATLAB R2014a. The MathWorks Inc., Natick, Massachusetts.
- Meigh, J. 1995. The impact of small farm reservoirs on urban water supplies in Botswana. *Natural Resources Forum*, 19: 71-83.
- Microsoft Excel Microsoft, Redmond, Washington.
- Moalafhi, D. B., R. Tsheko, J. R. Atlhopheng, P. T. Odirile, and S. Masike. 2012. Implications of climate change on water resources of Botswana.
- Mosha, A. C. 1996. The City of Gaborone, Botswana: Planning and Management. *Ambio*, 25: 118-125. DOI: 10.2307/4314437
- Author. 1966. Gaborone Developed As Capital City of New State, Botswana. *Nashua Telegraph* 09-11-1966.
- NOAA (a). 2014. Where is all of the Earth's Water? Ocean Facts. Retrieved 24 May 2015, from <http://oceanservice.noaa.gov/facts/wherewater.html>.
- NOAA (b). 2015. Dams and Reservoirs: Yangtze - 1800 - 2010. Science on a Sphere. Retrieved 26 April 2015, from <http://sos.noaa.gov/Datasets/dataset.php?id=477>.
- OECD, 2007. Botswana Country Study. Report. [in Swedish, English summary]
- Palaniappan, M., P. H. Gleick, L. Allen, M. J. Cohen, J. Christian-Smith, and C. Smith. 2010. *Clearing the Water- A focus on water quality solutions*. Nairobi, Kenya: United Nations Environment Programme
- Peel, M. C., B. L. Finlayson, and T. A. McMahon. 2007. Updated world map of the Köppen-Geiger climate classification. *Hydrology and earth system sciences discussions*, 4: 439-473.
- Pilesjö, P., and A. Hasan. 2014. A Triangular Form-based Multiple Flow Algorithm to Estimate Overland Flow Distribution and Accumulation on a Digital Elevation Model. *Transactions in GIS*, 18: 108-124. DOI: 10.1111/tgis.12015
- Rijsberman, F. R. 2006. Water scarcity: Fact or fiction? *Agricultural Water Management*, 80: 5-22. DOI: <http://dx.doi.org/10.1016/j.agwat.2005.07.001>
- SADC, 2012. Regional Infrastructure Development Master Plan: Water Sector Plan 2012. Report. [in Swedish, English summary]
- Samani, Z. 2000. Estimating solar radiation and evapotranspiration using minimum climatological data. *Journal of Irrigation and Drainage Engineering*, 126: 265-267.
- SBHL, 2011. Sustainable Development Report 2011. Report. [in Swedish, English summary]
- Schäuble, H., O. Marinoni, and M. Hinderer. 2008. A GIS-based method to calculate flow accumulation by considering dams and their specific operation time. *Computers & Geosciences*, 34: 635-646.
- Scudder, T. 2008. Okavango River Basin. In *Management of Transboundary Rivers and Lakes*, eds. O. Varis, A. Biswas, and C. Tortajada, 81-103. Springer Berlin Heidelberg.
- Sebekedi, V. n.d. Population Projections for Botswana: 2001-2031. ed. C. S. Office. Gaborone, Botswana.
- Sebudubudu, D. 2010. The impact of good governance on development and poverty in Africa: Botswana-A relatively successful African initiative. *African Journal of Political Science and International Relations*, 4: 249-262.
- Siderius, W. 1971. Soils and Irrigation Potential of the Mahalapye and Mogobane Pilot Schemes. *UNDP Surveys and Training for the Development of Water Resources and Agricultural Production: Botswana*

- Swatuk, L. A., and D. Rahm. 2004. Integrating policy, disintegrating practice: water resources management in Botswana. *Physics and Chemistry of the Earth*, 29: 1357-1364. DOI: 10.1016/j.pce.2004.09.011
- Tarnavsky, E., D. Grimes, R. Maidment, E. Black, R. P. Allan, M. Stringer, R. Chadwick, and F. Kayitakire. 2014. Extension of the TAMSAT satellite-based rainfall monitoring over Africa and from 1983 to present. *Journal of Applied Meteorology and Climatology*, 53: 2805-2822.
- The World Bank, 1983. Staff Appraisal Report Botswana: Third Water Supply Project. Report 4378-BT, Washington, DC. [in Swedish, English summary]
- Van der Ploeg, F. 2011. Natural resources: Curse or blessing? *Journal of Economic Literature*: 366-420.
- van Zyl, A. 2012. Botswana's North-South Carrier Water Transfer Scheme: A Strategy for Ensuring Economic Growth. *SAICE Civil Engineering*, 20: 49-51.
- Vitousek, P. M., H. A. Mooney, J. Lubchenco, and J. M. Melillo. 1997. Human domination of Earth's ecosystems. *Science*, 277: 494-499.
- Water Utilities Corporation. n.d. Dam Levels and Water Supply Situation. Retrieved 1 April 2015, from <http://www.wuc.bw/wuc-content.php?cid=109>.
- World Economic Forum, 2014. Global Risks 2014: Insight Report. World Economic Forum, Report. [in Swedish, English summary]

## 11. Appendix 1

The following appendix shows the process followed when evapotranspiration was calculated. It is a combination of the methods suggested by the FAO for monthly evapotranspiration and evapotranspiration with few climate data.

### 11.1 FAO evapotranspiration

#### Parameters

Average monthly minimum (1985-2010)=	degrees
Average monthly maximum (1985-2010)=	degrees
$T_{\text{mean}}=(13.2+28.4)/2 =$	degrees
Altitude=	1000m
P= Atmospheric Pressure=	90kPa
$\Delta$ = slope vapour pressure curve [kPa °C <sup>-1</sup> =	kPa °C <sup>-1</sup>
$\gamma$ =Psychrometric constant (g) for different altitudes (z)=	0.06 kPa/degree C
$U_2$ = wind speed= 2m/s $(1+0.34u_2) = (1+0.34(2)) =$	1.68
$\Delta/[\Delta+\gamma (1+0.34u_2)] =$	
$\gamma/[\Delta+\gamma (1+0.34u_2)] =$	
$900/( T_{\text{mean}}+273) U_2 =$	

#### Vapour pressure deficit/ Estimation of humidity data

Assume $T_{\text{dew}} \approx T_{\text{min}}$	degrees
$e_a$ =	kPa
$e^{\circ}(T_{\text{min}})$ = Saturation vapour pressure	kPa
$e^{\circ}(T_{\text{max}})$ =	kPa
$e_s = (e^{\circ}(T_{\text{max}}) + e^{\circ}(T_{\text{min}}))/2 =$	kPa
Vapour pressure deficit ( $e_s - e_a$ )=	kPa

### Radiation

$R_s = \text{solar radiation}$ $= 0.16 \text{ sqrt}(T_{\text{max}} - T_{\text{min}}) R_a =$	
Average $R_a$ according to table 2.6	$\text{MJ m}^{-2} \text{ day}^{-1}$
$R_s = 0.624(33.40)$	$\text{MJ m}^{-2} \text{ day}^{-1}$
$R_{s0} = \text{clear sky conditions}$ $= [0.75 + 2(\text{elevation}/100000)] R_a$	$\text{MJ m}^{-2} \text{ day}^{-1}$
$R_s / R_{s0} =$	
$R_{ns} = 0.77(R_s)$	$\text{MJ m}^{-2} \text{ day}^{-1}$

From table 2.8 $\sigma T_{\text{max}}^4$	$\text{MJ m}^{-2} \text{ day}^{-1}$
From table 2.8 $\sigma T_{\text{min}}^4$	$\text{MJ m}^{-2} \text{ day}^{-1}$
$(\sigma T_{\text{max}}^4 + \sigma T_{\text{min}}^4) / 2 = (40.60 + 32.88) / 2$	$\text{MJ m}^{-2} \text{ day}^{-1}$
Then: $(0.34 - 0.14 \text{ sqrt } e_a)$	
For: $R_s / R_{s0} =$	
Then: $(1.35 R_s / R_{s0} - 0.35) = [1.35(0.81) - 0.35] =$	
$R_{nl} = 36.74(0.167) 0.7435$	$\text{MJ m}^{-2} \text{ day}^{-1}$
$R_n = R_{ns} - R_{nl} = 16.04 - 4.56 =$	$\text{MJ m}^{-2} \text{ day}^{-1}$
Assume $G = \text{soil heat flux density} =$	$0 \text{ MJ m}^{-2} \text{ day}^{-1}$
$R_n - G = (11.48 - 0) =$	$\text{MJ m}^{-2} \text{ day}^{-1}$
$0.408(R_n - G) = 0.408(11.48)$	$\text{mm/day}$

### Grass reference evapotranspiration

$0.408(R_n - G) \Delta / [\Delta + \gamma (1 + 0.34u_2)]$ $= 0.408(11.48) (0.603)$	$\text{mm/day}$
$900 / (T + 273) u_2 (e_s - e_a) \gamma / [\Delta + \gamma (1 + 0.34u_2)]$ $= 900 / (20.8 + 273) (2) (1.17) (0.236) =$	$\text{mm/day}$
$ET_0 = (2.82 + 1.69) =$	$\text{mm/day}$
<b>Evaporation per year =</b>	<b><math>\text{mm/year}</math></b>

## **Institutionen för naturgeografi och ekosystemvetenskap, Lunds Universitet.**

Student examensarbete (Seminarieuppsatser). Uppsatserna finns tillgängliga på institutionens geobibliotek, Sölvegatan 12, 223 62 LUND. Serien startade 1985. Hela listan och själva uppsatserna är även tillgängliga på LUP student papers ([www.nateko.lu.se/masterthesis](http://www.nateko.lu.se/masterthesis)) och via Geobiblioteket ([www.geobib.lu.se](http://www.geobib.lu.se))

The student thesis reports are available at the Geo-Library, Department of Physical Geography and Ecosystem Science, University of Lund, Sölvegatan 12, S-223 62 Lund, Sweden. Report series started 1985. The complete list and electronic versions are also electronic available at the LUP student papers ([www.nateko.lu.se/masterthesis](http://www.nateko.lu.se/masterthesis)) and through the Geo-library ([www.geobib.lu.se](http://www.geobib.lu.se))

- 310 Jenny Ahlstrand (2014) En jämförelse av två riskkarteringar av fosforförlust från jordbruksmark – Utförda med Ekologgruppens enkla verktyg och erosionsmodellen USPED
- 311 William Walker (2014) Planning Green Infrastructure Using Habitat Modelling. A Case Study of the Common Toad in Lomma Municipality
- 312 Christiana Marie Walcher (2014) Effects of methane and coastal erosion on subsea-permafrost and emissions
- 313 Anette Fast (2014) Konsekvenser av stigande havsnivå för ett kustsamhälle- en fallstudie av VA systemet i Beddingestrand
- 314 Maja Jensen (2014) Stubbrytningens klimatpåverkan. En studie av stubbrytningens kortsiktiga effekter på koldioxidbalansen i boreal barrskog
- 315 Emelie Norhagen (2014) Växters fenologiska svar på ett förändrat klimat - modellering av knoppsprickning för hägg, björk och asp i Skåne
- 316 Liisi Nõgu (2014) The effects of site preparation on carbon fluxes at two clear-cuts in southern Sweden
- 317 Julian Will (2014) Development of an automated matching algorithm to assess the quality of the OpenStreetMap road network - A case study in Göteborg, Sweden
- 318 Niklas Olén (2011) Water drainage from a Swedish waste treatment facility and the expected effect of climate change
- 319 Wösel Thoresen (2014) Burn the forest - Let it live. Identifying potential areas for controlled forest fires on Gotland using Geographic Information System
- 320 Jurgen van Tiggelen (2014) Assimilation of satellite data and in-situ data for the improvement of global radiation maps in the Netherlands.
- 321 Sam Khallaghi (2014) Posidonia Oceanica habitat mapping in shallow coastal waters along Losinj Island, Croatia using Geoeye-1 multispectral imagery.
- 322 Patrizia Vollmar (2014) The influence of climate and land cover on wildfire patterns in the conterminous United States
- 323 Marco Giljum (2014) Object-Based Classification of Vegetation at Stordalen Mire near Abisko by using High-Resolution Aerial Imagery
- 324 Marit Aalrust Ripel (2014) Natural hazards and farmers experience of climate change on highly populated Mount Elgon, Uganda
- 325 Benjamin Kayatz (2014) Modelling of nitrous oxide emissions from clover grass ley – wheat crop rotations in central eastern Germany - An application of DNDC

- 326 Maxime Rwaka (2014) An attempt to investigate the impact of 1994 Tutsi  
Genocide in Rwanda on Landscape using Remote Sensing and GIS analysis
- 327 Ruibin Xu (2014) Spatial analysis for the distribution of cells in tissue sections
- 328 Annabelle Finck (2014) Bird biodiversity in relation to forest composition in  
Sweden
- 329 Tetiana Svystun (2015) Modeling the potential impact of climate change on  
the distribution of Western Corn Rootworm in Europe”
- 330 Joel Forsmoo (2014) The European Corn Borer in Sweden: A Future  
Perspective Based on a Phenological Model Approach
- 331 Andrew Ekoka Mwambo (2015) Estimation of Cropland Ecological Footprint  
within Danish Climate Commissions 2050 Scenarios for Land use and  
Bioenergy Consumption
- 332 Anna Lindstein (2015) Land- atmosphere exchange of carbon dioxide in a high  
Arctic fen: importance of wintertime fluxes
- 333 Karla Susana Markley Vergara (2015) Present and near future water  
availability for closing yield gaps in four crops in South America
- 334 Klara Århem & Fredrik Fredén (2015) Land cover change and its influence on  
soil erosion in the Mara region, Tanzania: Using satellite remote sensing and  
the Revised Universal Soil Loss Equation (RUSLE) to map land degradation  
between 1986 and 2013
- 335 Fei Lu (2015) Compute a Crowdedness Index on Historical GIS Data- A Case  
Study of Hög Parish, Sweden, 1812-1920
- 336 Lina Allesson (2015) Impact of photo-chemical processing of dissolved  
organic carbon on the bacterial respiratory quotient in aquatic ecosystems
- 337 Andreas Kiik (2015) Cartographic design of thematic polygons: a comparison  
using eye-movement metrics analysis
- 338 Iain Lednor (2015) Testing the robustness of the Plant Phenology Index to  
changes in temperature
- 339 Louise Hannon-Bradshaw (2015) Submerged Landscapes- Locating Mesolithic  
settlements in Blekinge, Sweden
- 340 Elisabeth Maria Farrington (2015) The Water Crisis in Gaborone-  
Investigating the underlying factors resulting in the ‘failure’ of the Gaborone  
Dam, Botswana