



THE PARK OF THE INVOLUNTARY TOURIST

AAHM01: Examensarbete i arkitektur/Degree Project in Architecture
Lunds Tekniska Högskola, Lund/ Faculty of Engineering, Lund University
2008

The Park of the Involuntary Tourist
Kajsa Lawaczek Körner

Examinator: Abelardo Gonzalez
Tutor: Christer Malmström, John Stack Ross



Abstract

This diploma work is about the situation of refugees in a world of conflicts, borders and tourists, designed as a critical counterpoint to the competition "Venice Lagoon Park" organized by the magazine 2G, autumn 2007.

I have transformed the competition's program idea of giving tourists and visitors information, into a space for educating the public about refugees and their reality. The site is the same as in the competition brief; Sacca San Mattia, Venice, Italy.

Once upon a time

in a place called Europe there was a war caused by ignorance and fear. Finally, the evil forces were defeated by the good forces and years of cruelties and genocide came to an end. Europe suddenly found itself in a state of ruins and poverty, ruled by former warlords, good forces and communists.

The fear of another war and further poverty and economical crises was so immense that in the year of 1951 a Union was founded by the former warlords and good forces; the Republic of France, the Kingdom of Belgium, the Republic of West Germany, the Kingdom of Luxembourg, the Kingdom of Netherlands and the Republic of Italy. They called themselves the European Coal and Steel Union. As the years passed by, the Union grew bigger and changed name and agenda; they constituted laws to regulate trade, commerce and border control. The amount of different agreements to be signed grew, but the prime ministers and presidents happily signed the documents and treaties, except for a few who did not know what was best for their countries.

The 14th of June 1985 the first countries, Belgium, France, West Germany, Luxembourg and Netherlands, signed the Schengen Agreement. This document was, among other things, going to make it possible for the citizens of a Schengen Country to move and work where ever they wanted, as long as it was in one of the five countries. Everyone else was going to be excluded except for those with a lot of money or whoever accepted to work 24/7 for nothing.

They started to build the Country of Schengen, but it was not easy to keep all the outsiders out and as the number of country members grew, so did the need for control. They used all the best engineers and architects, and suddenly they found themselves surrounded by a great big wall. It was the best wall ever built, it was going to protect from bad and worse and no one could come in, and no one could go out because there was no door.

The citizens of Schengen did not know what was going on outside their wall anymore. The only thing they knew was that it was dangerous and should be kept out, and maybe their neighbours were dangerous too, and their children and friends, so they locked themselves up and stayed there. As the time passed by they grew ignorant and stupid, aggressive and scared.

So there they were behind their great big wall,
the wall without a door.

And little did they know and little was there to know,
except that all were controlled.

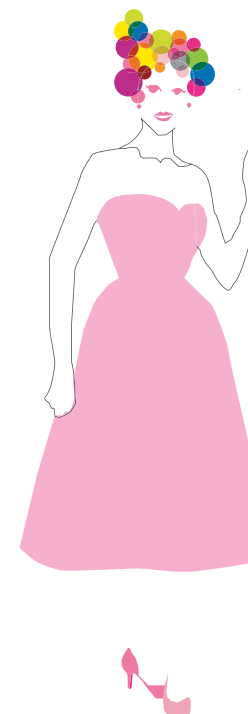



Venice Airport

VENICE LAGOON

ITALY

Burano

Sacca san Mattia

Murano

Sant Erasmo

Isola di San Michele

Venice

Lido

Scale 1:30000

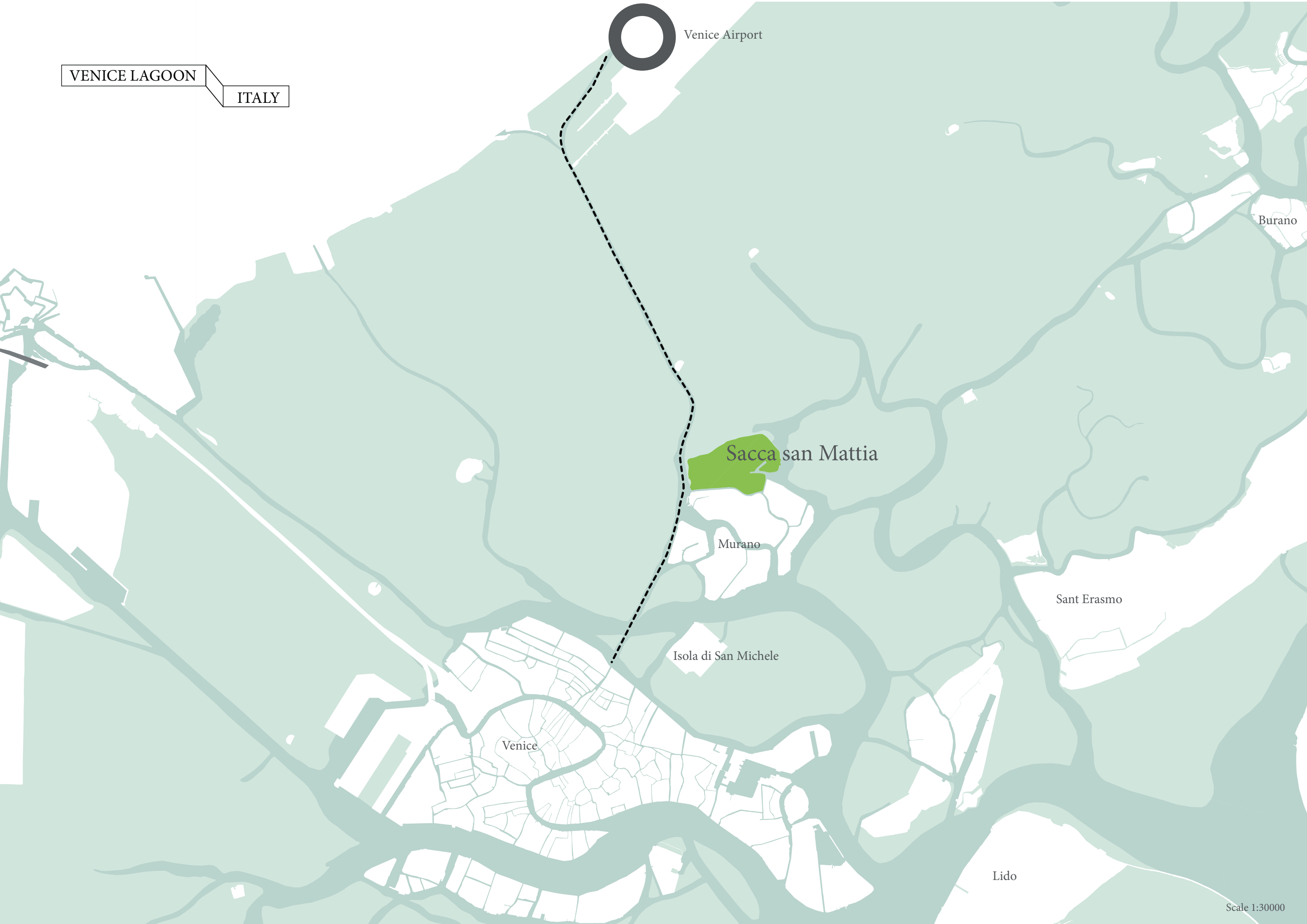

*Welcome to the Park
of the Involuntary
Tourist!*

A refugee

n. One who flees in search of refuge, as in times of war, political oppression, or religious persecution.

'refugee'. Dictionary.com. The American Heritage® Dictionary of the English Language, Fourth Edition. Houghton Mifflin Company, 2004. <http://dictionary.reference.com/browse/refugee> (accessed: March 14, 2008).

This diploma work is about the situation of refugees in a world of conflicts, borders and tourists, designed as a critical counterpoint to the competition "Venice Lagoon Park" organized by the magazine 2G, autumn 2007.

I have transformed the competition's program idea of giving tourists and visitors information, into a space for educating the public about refugees and their reality. The site is the same as in the competition brief; Sacca San Mattia, Venice, Italy, which has been used as a dump for the glass industry, and Murano, the main island of the Venetian glass industry located just south of it with frequent boat connection to Venice. The site's location in the lagoon is along the only water path between Venice and its airport. With the water path system being the most important infrastructural element in Venice, this makes it a good site to display my program.

The Park of the Involuntary Tourist- Greetings from Venice

About 50 million people are refugees in the world right now, according to Amnesty International (www.amnestyinternational.org). I made this to a starting point to express my criticism against the inhuman migration policy of The Schengen Agreement, tourism, and consumption. This is my idea of how Venice can be perceived in a new way as the Park of the Involuntary Tourist, where it is connected to its own past and present.

In the Adriatic sea outside Venice, as all over the Mediterranean sea, people drown and disappear when they try to get in to the E.U. This is a direct consequence of the E.U.'s migration policy and the implementation of the Schengen Agreement responding to conflict situations in the world.

"...at least 10,355 people have died since 1988 along the European frontiers. Among them 3,615 were missing in the sea. 7,245 migrants died in the Mediterranean sea, and through the Atlantic Ocean towards Spain, and 1.113 lost their life trying to cross Sahara desert in order to reach Europe."

Number of dead and lost refugees in the Adriatic sea year by year:

updated August 20th 2006

Year	Dead	Lost	Total
2004	21	7	28
2003	6	23	29
2002	14	0	14
2001	16	0	16
2000	19	14	33
1999	114	79	203
1998	26	21	47
1997	12	70	82
1996	13	0	13
1995	26	25	51
1994	13	11	24
1993	11	0	12
1991	12	0	12
Total	303	250	553

(Source:<http://fortresseurope.blogspot.com/2006/01/i-numeri-delladriatico-anno-per-anno.html>)

"Venice is anchored to its history which began with the decline of the Roman Empire of the West and the barbaric invasions. The barbarians, bringing destruction to the inhabited sections of the land, forced many populations to seek refuge on the numerous islands of the lagoon." (Source: All Venice in 140 color photographs by Eugenio Pucci)

Venice has throughout history been used as place on which people have projected contemporary interests and ideals, and its history has been written through these ideas. John Pemble writes in Venice rediscovered about the making of the notion and image of Venice in literature:

"poets, novelists, and librettists, as well as narrative and scientific historians [...] all produced a literature of 'romance' and 'philosophical research' in which the Venetian past, refracted by present preoccupations, became an index of national concerns and modern mentalities." (Pemble 1995:87) What we see or experience when we visit Venice is to some extent our construction of the past.

Instead of using Venice as a mirror to reflect our dreams on, Venice could be used to show a more accurate reality; the life of a refugee. Functions merely based on tourism and its needs, which is what the competition brief suggests, will not create a solid ground for Venice to rely on.

THE SCHENGEN AGREEMENT

E.U.

REPORT FROM THE BORDER

1951 European Coal and Steel Community is founded by France, West Germany, Belgium, Italy, Luxembourg, and the Netherlands.

1957 A Custom Union, the European Economic Community (EEC), and the European Atomic Energy Community (Euratom) is founded.

1967 The Merger Treaty the three communities were made into one single institution, the European Communities, also known as the European Community (EC).

1973

1980

1990

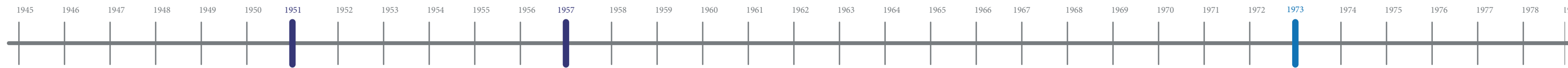
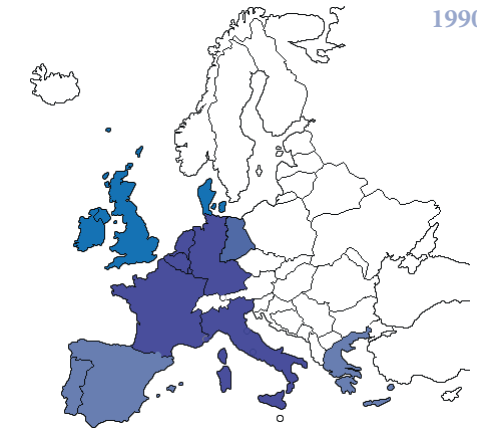
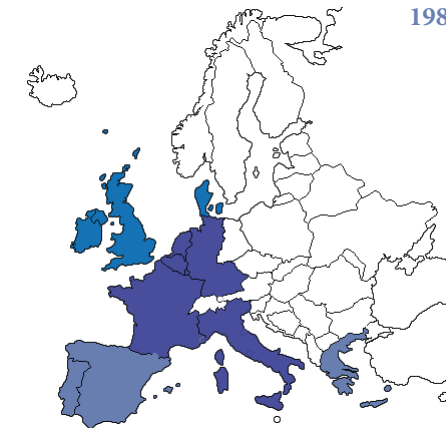
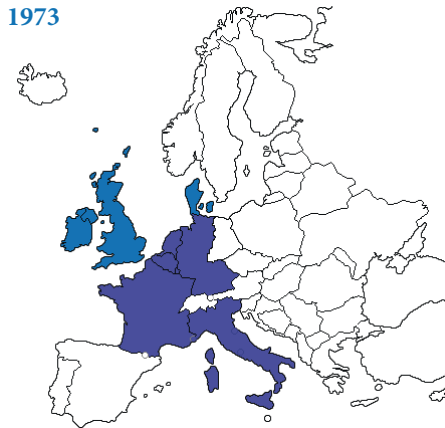
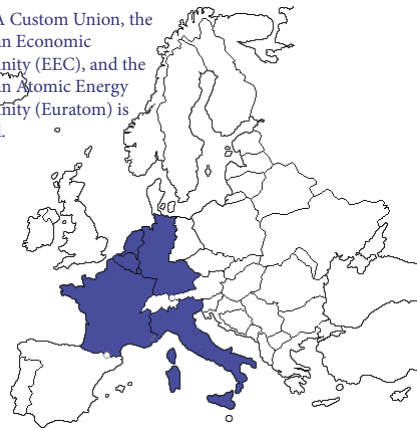

Implementation of The Schengen Agreement

Showing country and year of implementation

14 June 1985, the Schengen Agreement is signed by Belgium, France, West Germany, Luxembourg, and The Netherlands.

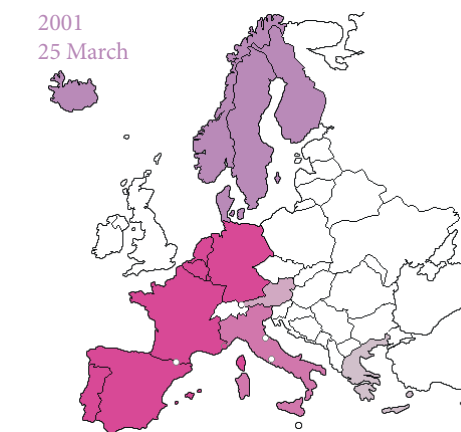
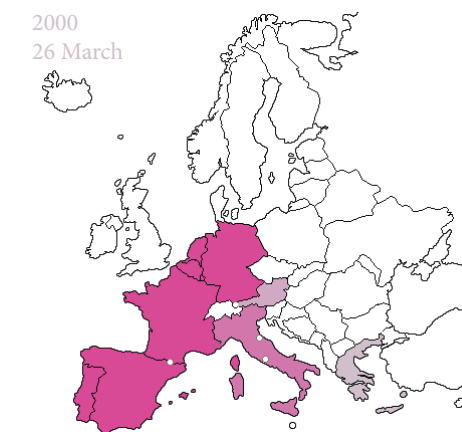
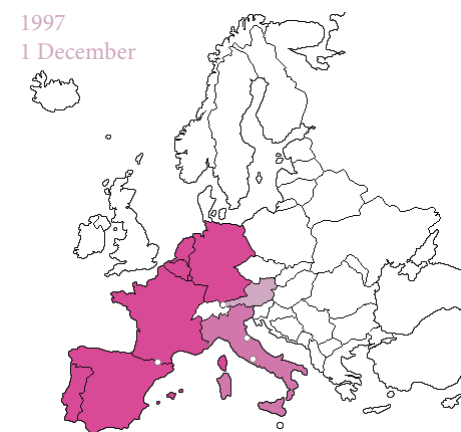
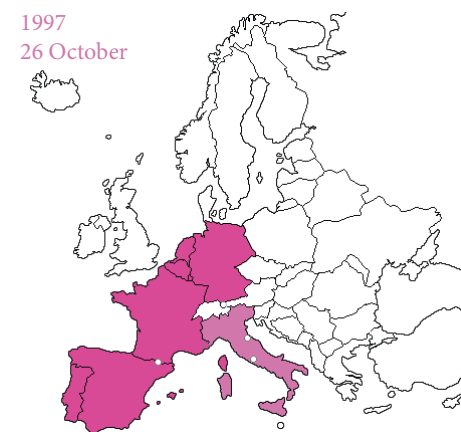
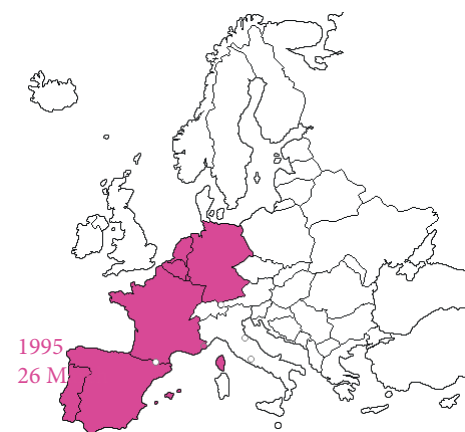

1 November 1993, the Maastricht Treaty came into force and from now on the community is called the European Union (EU).

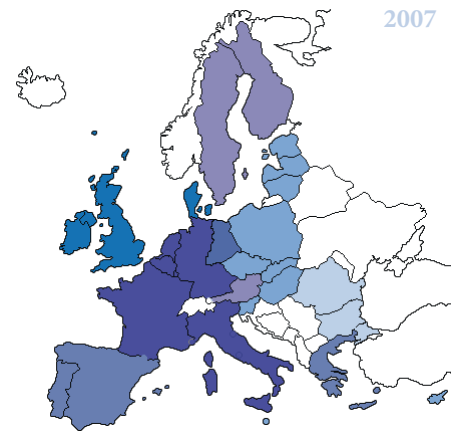
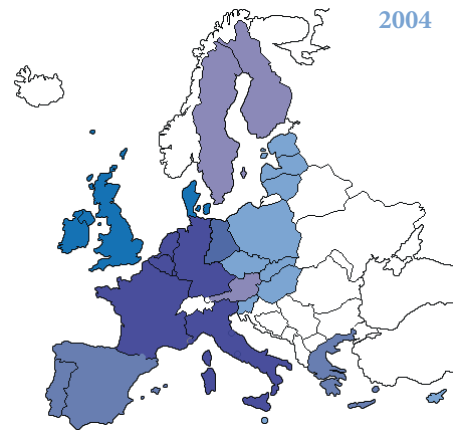
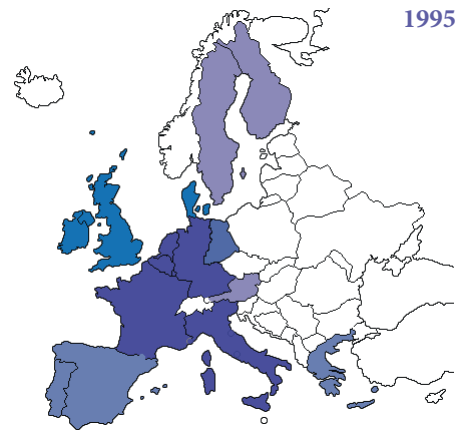

- Member countries of the European Union, E.U.:
- Republic of Ireland
 - United Kingdom
 - Portugal
 - Spain
 - France
 - Luxembourg
 - Belgium
 - Netherlands
 - Germany
 - Austria
 - Italy
 - Greece
 - Malta
 - Cyprus
 - Denmark
 - Sweden
 - Finland
 - Latvia
 - Lithuania
 - Estonia
 - Poland
 - Czech Republic
 - Slovakia
 - Slovenia
 - Bulgaria
 - Rumania
 - Hungary

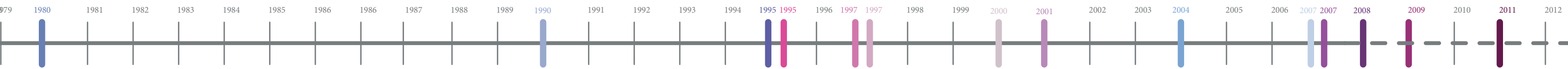

Countries who have implemented The Schengen Agreement:

- Portugal
- Spain
- France
- Luxembourg
- Belgium
- Netherlands
- Germany
- Austria
- Italy
- Greece
- Malta
- Denmark
- Sweden
- Finland
- Latvia
- Lithuania
- Estonia
- Poland
- Czech Republic
- Slovakia
- Slovenia
- Hungary
- Iceland
- Norway

Countries who are going to implement the Schengen Agreement:

- Bulgaria
- Rumania
- Cyprus
- Switzerland

Possible member countries of the Schengen Agreement:

- Ukraine
- Belarus
- United Kingdom
- Ireland
- Moldovia
- Turkey
- Bosnia Herzegovina
- Serbia
- Macedonia
- Albania
- Croatia
- Montenegro

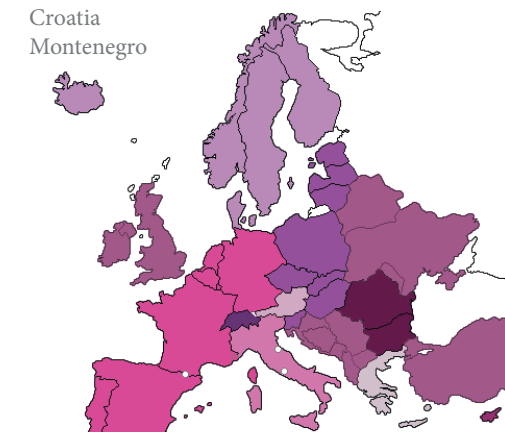
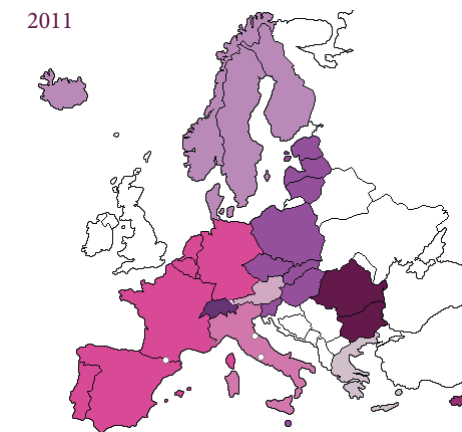
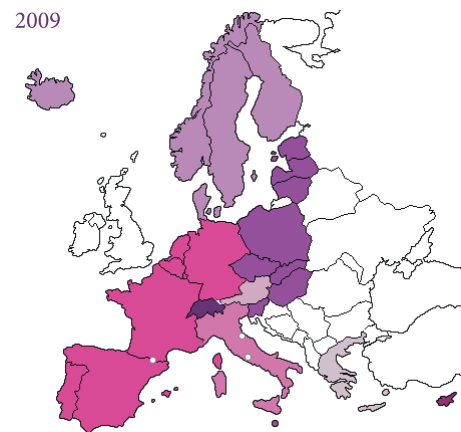
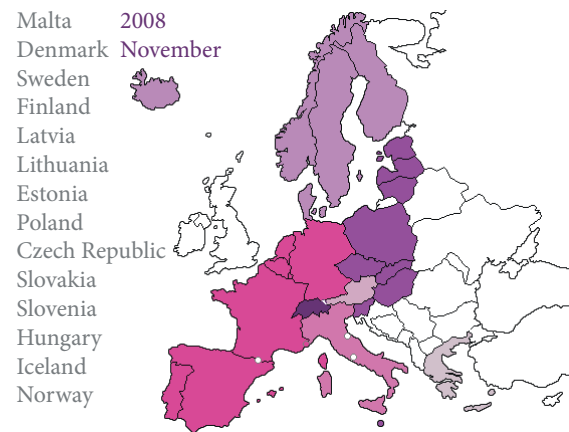
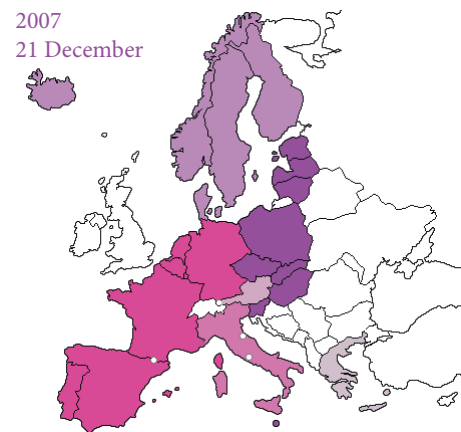

Member countries of the European Union 2008

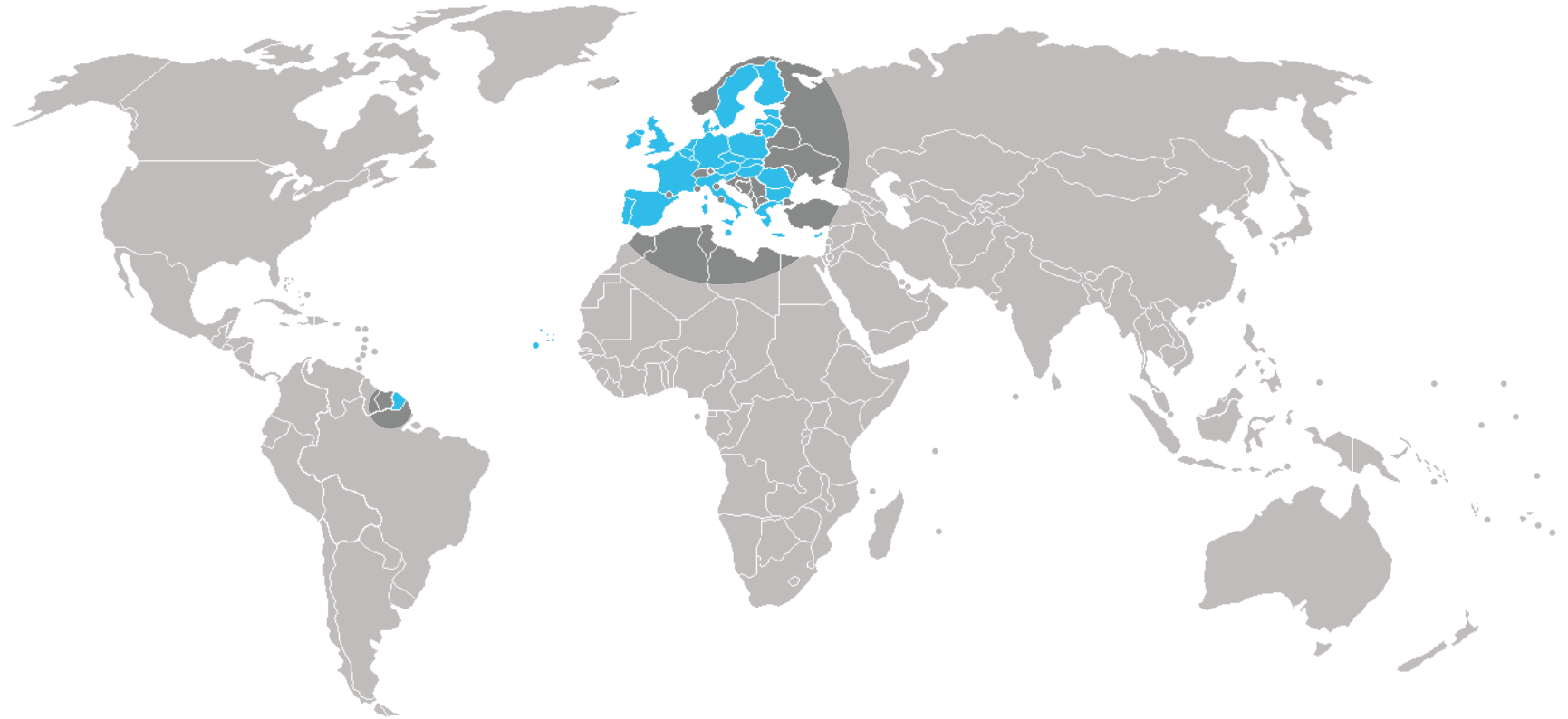

The European Union

The political climate after the end of World War II favoured Western European unity, seen by many as an escape from the extreme forms of nationalism which had devastated the continent. One of the first successful proposals for European cooperation came in 1951 with the European Coal and Steel Community. This had the aim of bringing together control of the coal and steel industries of its member states, principally France and Germany. This was with the aim that war between them would not then be possible, as coal and steel were the principal resources for waging war.” the first member states were France, Germany, Italy, Belgium, Netherlands and Luxembourg. This was followed by the Rome treaty creating the European Economic Community (EEC) in 1957, The Merger Treaty, the European Communities, in 1967, and several other agreements but finally ended in the foundation of the European Union on the 1st of December in 1993.

(source: www.wikipedia.org)

The Schengen Agreement

“The 1985 Schengen Agreement is an agreement among some European countries which allows for the abolition of systematic border controls between the participating countries. It also includes provisions on common policy on the temporary entry of persons (including the Schengen Visa), the harmonisation of external border controls, and cross-border police co-operation.” The agreement was signed on the 14th of June 1985 by Belgium, France, West Germany, Luxembourg and Netherlands, but was first implemented on the 26th of March 1995.

(source: www.wikipedia.org)

BELARUS
Member countries of the Schengen Agreement 2008

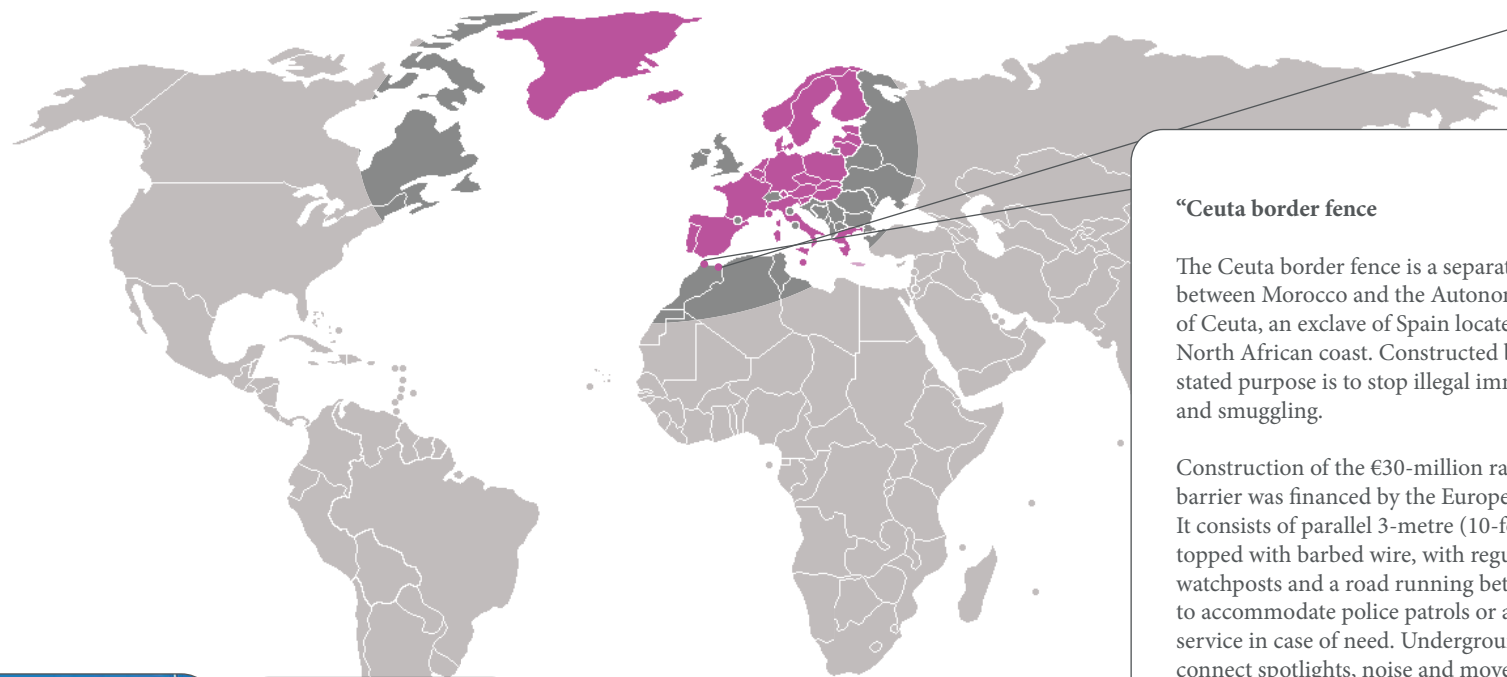

“Ceuta border fence

The Ceuta border fence is a separation barrier between Morocco and the Autonomous City of Ceuta, an exclave of Spain located on the North African coast. Constructed by Spain, its stated purpose is to stop illegal immigration and smuggling.

Construction of the €30-million razor wire barrier was financed by the European Union. It consists of parallel 3-metre (10-foot) fences topped with barbed wire, with regular watchposts and a road running between them to accommodate police patrols or ambulance service in case of need. Underground cables connect spotlights, noise and movement sensors, and video cameras to a central control booth.

Morocco has objected to the construction of the barrier since it does not recognize Spanish sovereignty in Ceuta.”

Source: Wikipedia, www.wikipedia.com

“Melilla border fence

The Melilla border fence is a separation barrier between Morocco and the Spanish city of Melilla. Constructed by Spain, its stated purpose is to stop illegal immigration and smuggling.

In October 2005, over 700 Sub-Saharan migrants camping on nearby Mount Gurugú tried to enter Spanish territory from the Moroccan border. Many of them were shot in the back, apparently from the Moroccan Gendarmerie Royale positions.

Before the third fence came to be implemented following this and similar incidents, the mountainous buffer zone between Spanish and Moroccan border patrol positions which lies next to the fence registered a hectic activity with subsaharan people provisionally camped there while preparing massive assaults on the fence, something which became a tactic in order to outnumber the Spanish border patrols.

Massive intrusions (or "assaults" at the fence, as the Spanish press put it) of subsaharan people via Melilla had become a Spanish and, to some extent, European Union issue, which prompted the Spanish government of José Luis Rodríguez Zapatero in 2005 to build up a third fence next to the two deteriorated existing ones, in order to completely seal the border outside of the regular checkpoints.

This third razor wire barrier cost Spain €33 million (US\$35 million) to construct. It consists of 11 km (7 miles) of parallel 3 m (10 ft) high fences topped with barbed wire, with regular watchposts and a road running between them to accommodate either police patrols or ambulance service in case of need. Underground cables connect spotlights, noise and movement sensors, and video cameras to a central control booth. Its height is currently being doubled to 6 m. since the immigrants were surpassing the previous fences equipped with self made stairs. Also, in order to facilitate the intruder's detention, devices to slow them harmlessly were added.

Apparently the new fence has succeeded in deterring new massive intrusions and the subsaharan camp sites in the buffer zone have mostly disbanded. From these, Amnesty International and Médecins Sans Frontières accused the Moroccan government of dumping over 500 people of various subsaharan countries (some of them claiming to be validly registered as political refugees) in an uninhabited area in the Sahara Desert without food or water supplies.

Morocco has objected to the construction of the barrier since it does not recognize Spanish sovereignty in Melilla.”

Source: Wikipedia, www.wikipedia.com



Border control between Ceuta, Spain, and Morocco.



Border fence between Ceuta, Spain, and Morocco.

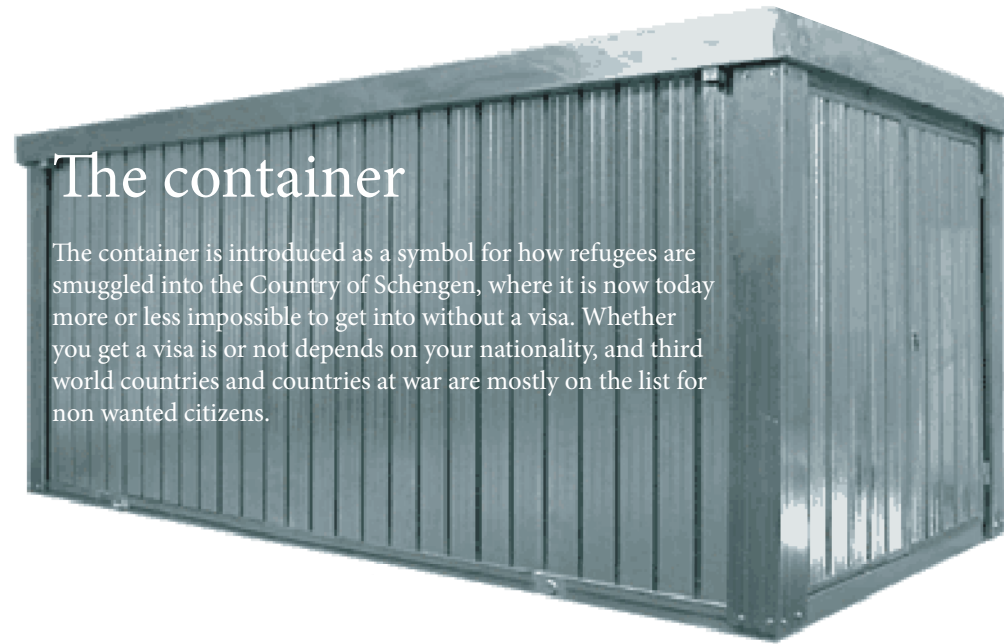
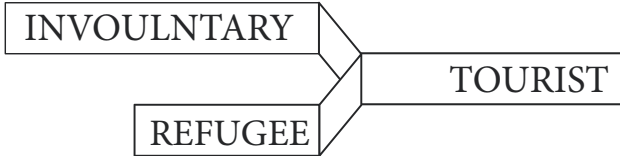

The container

The container is introduced as a symbol for how refugees are smuggled into the Country of Schengen, where it is now today more or less impossible to get into without a visa. Whether you get a visa is or not depends on your nationality, and third world countries and countries at war are mostly on the list for non wanted citizens.

Involuntary and voluntary tourist

The name “involuntary” tourist is another way of looking at migration and tourism. Being a voluntary tourist is commonly accepted, even though its consequences often are pollution and exploitation. The “involuntary” tourist, however, is typically not accepted. Being a tourist comes with no additional human rights, but being a refugee gives you, according to international law and the UN convention, certain rights as protection. As a refugee you are an “involuntary” tourist. Refugees are often kept outside of borders or confined to camps. I want to expose this situation, as a comment on how refugees are treated and looked upon. This is not about solving the refugee issue; it is about raising the question.

This is a de-romanticizing of Venice which gives it a new function and raises questions concerning immigration policy in the EU under the Schengen Agreement. It is a critical counterpoint to Venice's tourism based on romanticism, falsification of history, colonialism and consumption. Tourism has transformed cities and countries into gentrified scenes of romantic dreams and instant pleasures. Venice is the pinnacle of this phenomenon. Instead of an urbanism of self sustaining functions, the city exists primarily to satisfy a market of tourism, which increasingly becomes nothing more than a superficial spectacle. To what extent will it in the end differ from fabricated and artificial places such as Disney World or Fantasy Cities, as described by John Hannigan in Fantasy City.¹

Fantasy City combines sports, restaurants, entertainment and high-tech experiences to create a culture capital to be consumed, “What is significant is not so much the role of consumption in helping to assert status and identity but the fact that consumption is increasingly occurring within the context of programmed leisure experiences.” (Hannigan 1999:70)

The competition's program encourage a development towards Fantasy City, which I think will do more harm than good to Venice, because it will not give a real function to the city. Architecture generated out of consumption does not create a sustainable design.



VOLUNTARY

TOURIST



In my opinion, tourism as something developed and created out of consumption and materialism, reduces the tourist to a compulsory consumer with all and no choices; exploring, conquering, colonizing, polluting and exploiting local economies until the location is replaced by another. Applying a Marxist model of production on tourism makes it possible to separate tourism as a commodity from the sentimental aspects and values of tourism.

TOURISM AS A MARXIST

MODEL OF PRODUCTION

DEFINITION OF TOURISM

- A. the social relation in production of a product establishing the use value of a product
- B. a commodity; the image of a place/an experience (product+use value)
- C. an action; the act of consuming an image

The producers: The image-maker

The social relationship between producers, image-making, and the sum of this labour decides the usevalue of the image and in this way the commodity is created. **A**

The sum of their labour

Commodity fetishism

Creating value: creating the experience.

The commodity is an image of either the past re-invented or an image of the future. **B**

Experience being consumption; we have made our experiences in to an act of consumption and creating the value is to create the experience, where tourism can be understood as a social relation based on consumption.

Marx says that the social relation between the producers and the sum of their labour gives the commodity a value; the use value. The products of labour become a commodity as a consequence of the social relation between the producer and the produced, "[...] social things whose qualities are at the same time perceptible and imperceptible by the senses." He continues by saying that the fetishism which attaches itself to the products of labour, when they are produced as commodities is inseparable from the production of commodities, and this fetishism is expressed when the commodity is exchanged in its exchange value. The fetishism of a commodity decides its exchangeability, which makes "value" a subjective matter. The exchange value of a commodity is not a fact, it is a social process.

"Riches (use value) are the attribute of men, [exchange] value is the attribute of commodities."

(Source: The Capital Volume One, Part I: Commodities and Money, Chapter One: Commodities Section 4 - The Fetishism of Commodities and the Secret thereof, Marx, K.)

My interpretation of Tourism in a Marxist model of production:

Tourism= the social relation in production of a product establishing the use value of a product
 a commodity; the image of a place/an experience (product+use value)
 an action; the act of consuming an image

The driving force of consumption is "commodity fetishism" which, in my opinion, is image-making and the creation of desire. The social relationship between producers, image-making, and the sum of this labour decides the usevalue of the image and in this way the commodity is created. The commodity is an image of either the past re-invented or an image of the future. The image-making; the commodity fetishism is expressed when the image is consumed (exchanged); the experience. The experience being the exchange value. Experience being consumption; we have made our experiences in to an act of consumption and creating the value is to create the experience, where tourism can be understood as a social relation based on consumption.

The driving force of **consumption** is "commodity fetishism" which, in my opinion, is image-making and the creation of desire.

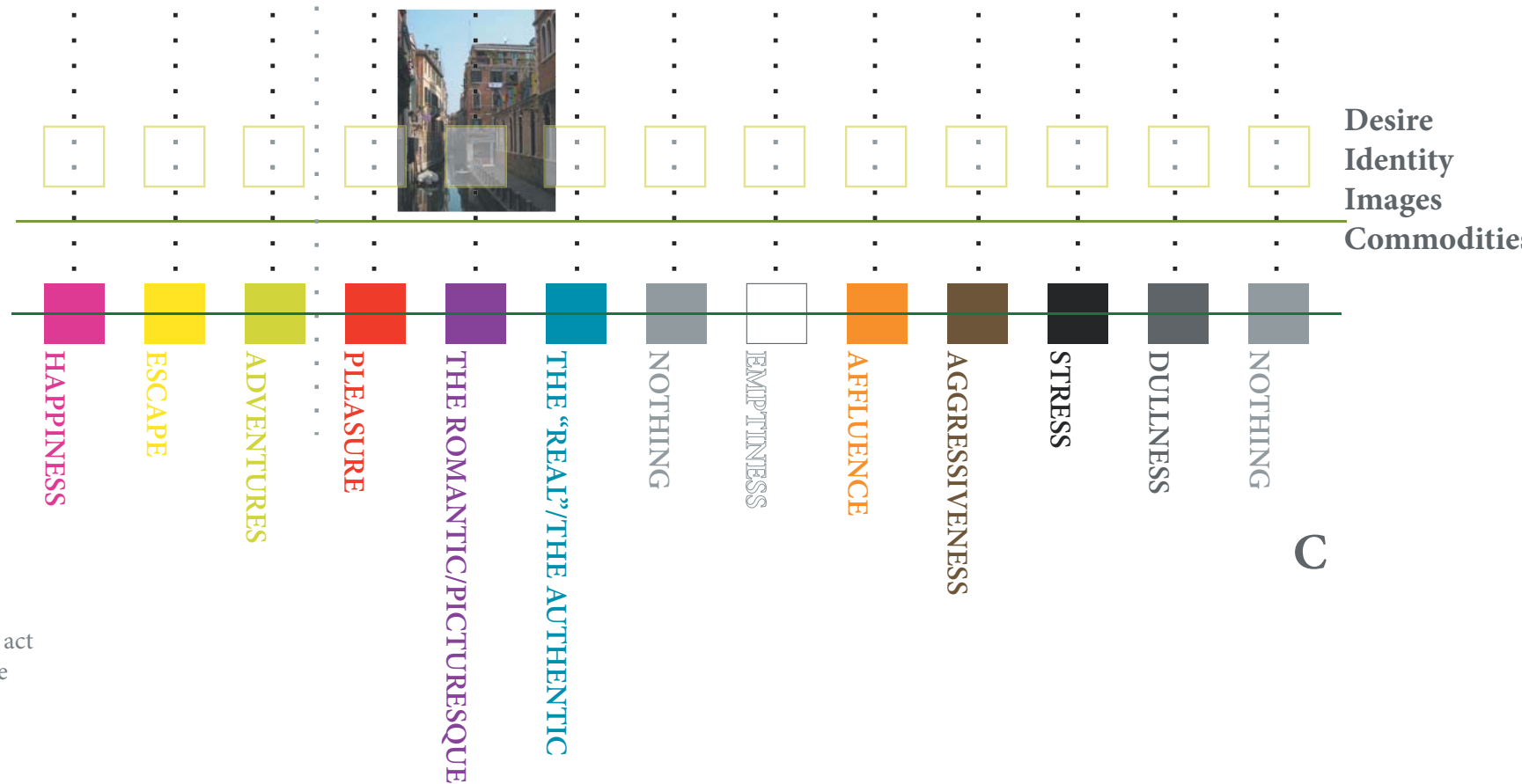

THE ASYLUM PROCESS



The asylum process

The asylum process is an obstacle a refugee has to face. It consists of 12 steps, where two are refusals of entry and residence permits and the rest are a set of different decisions by authorities. Looking at the situation in the world today refugees from countries at war or where human rights are violated are often refused entry and sent back to a life in uncertainty. It is a game of life and death, where the journey can be as dangerous as the situation you are trying to escape. The actual situation of a refugee, what and why she or he has fled etc., seems to be more or less unimportant for the decision makers.

Administrative process of the asylum process

- a. border control
- b. seek asylum
- c. decision
- d. immediate refusal or e. trial of case
- f. decision
- g. residence permit
- h. refusal of entry
- i. appeal of decision
- j. decision of appeal
- k. residence permit
- l. refusal of entry

The probability of getting a residence permit is, according to the asylum process, 3/8 (37,5 %) and a refusal of entry is 5/8 (62,5%), which almost agrees with the actual situation in different countries, according to UN statistics (2006).

During the year of 2006 Italy took 17 919 decisions regarding refugees, 11 547 persons (64,4%) were refused entry and 6 372 persons (35,6%) got a residence permit.

(Source: The Swedish migration office and UN)

THE ASYLUM PROCESS

PROBABILITY CALCULI

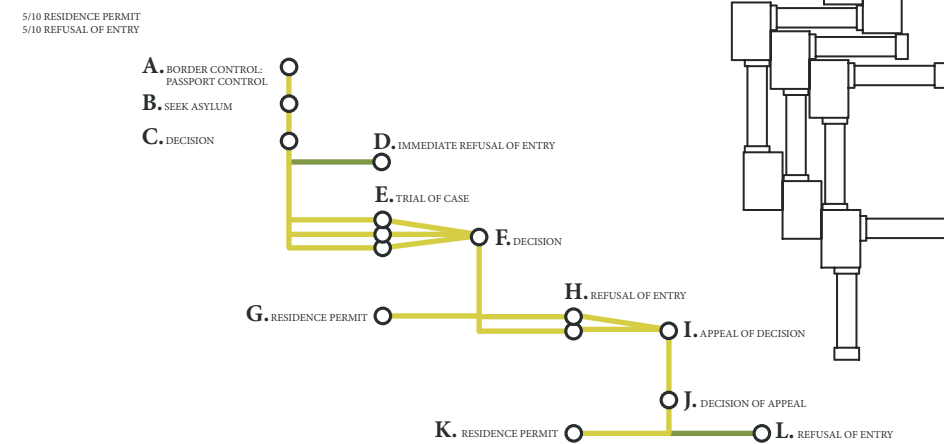
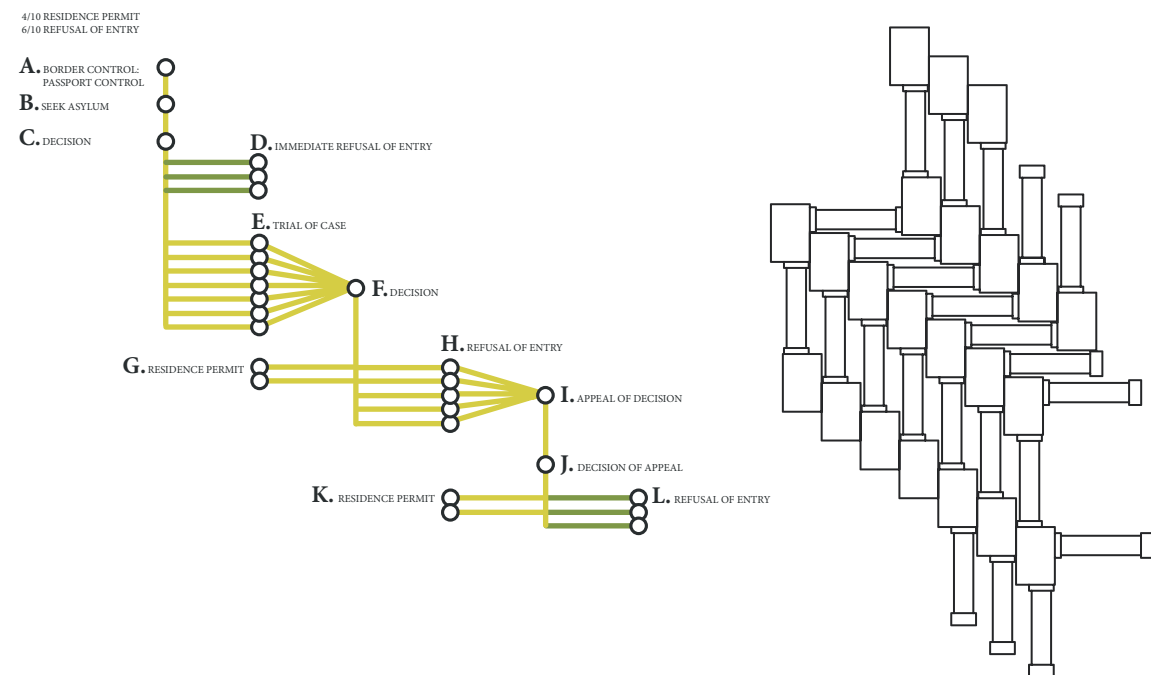
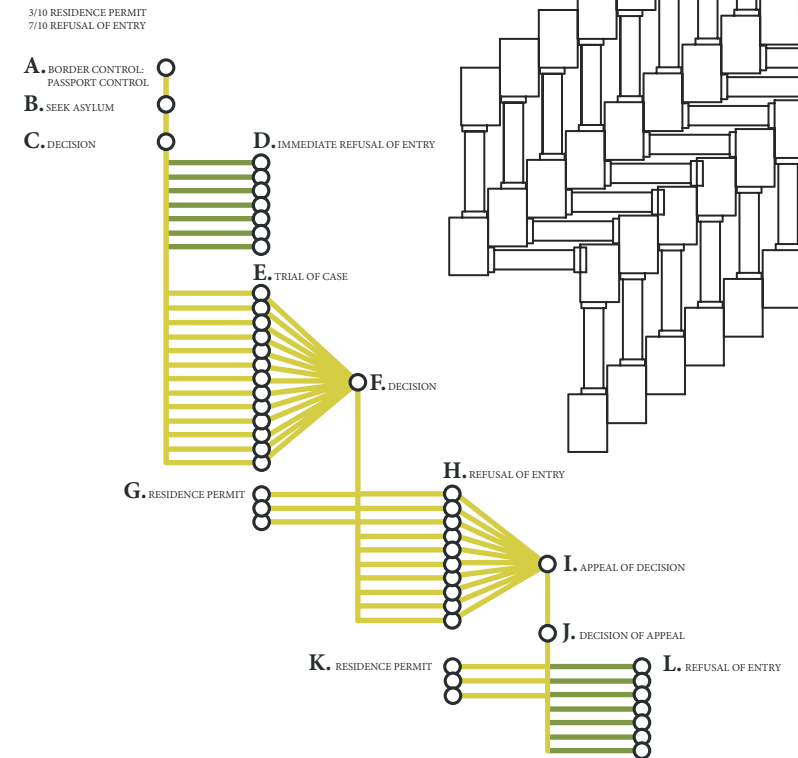
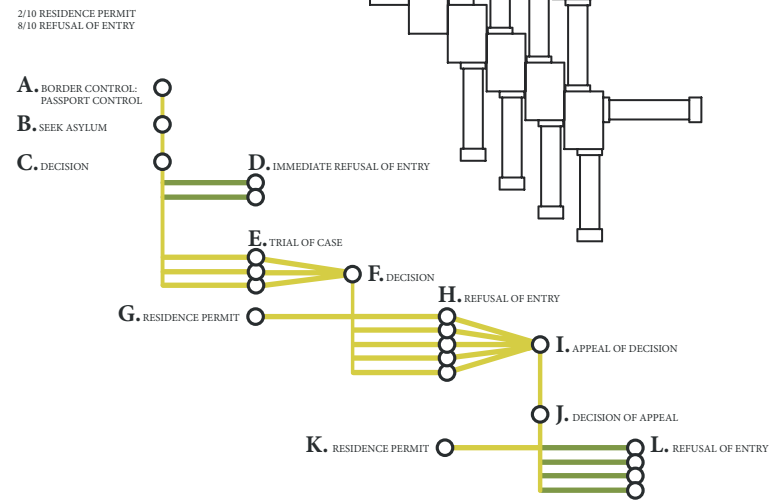
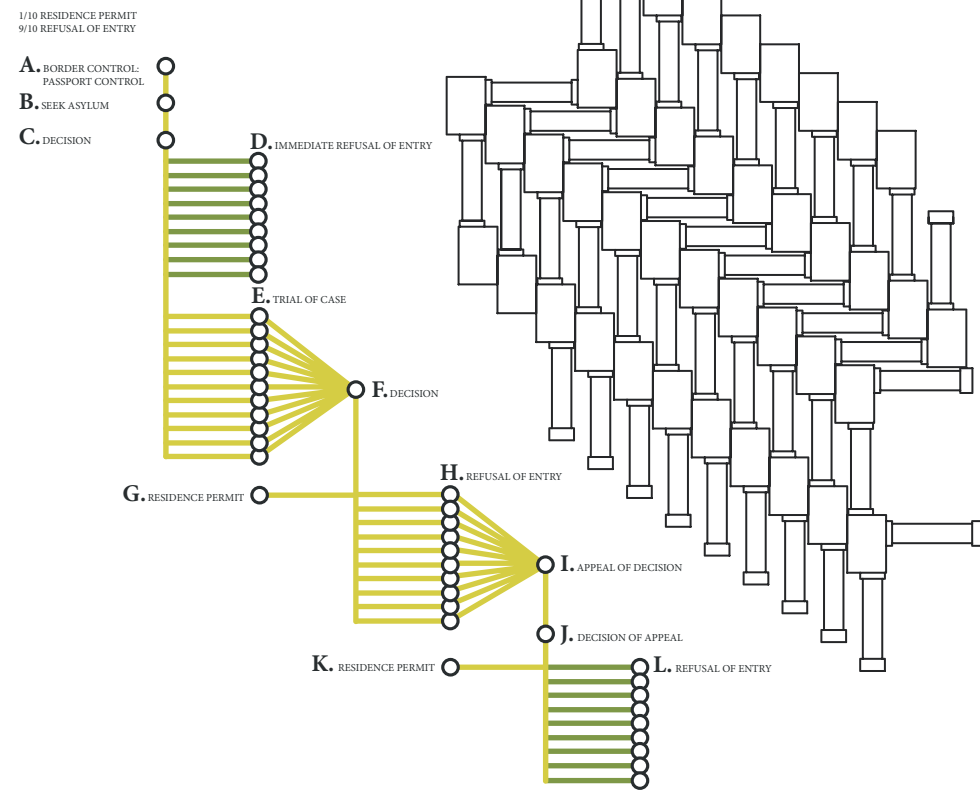

THE ASYLUM PROCESS

PROBABILITY CALCULI

6/10 RESIDENCE PERMIT
4/10 REFUSAL OF ENTRY

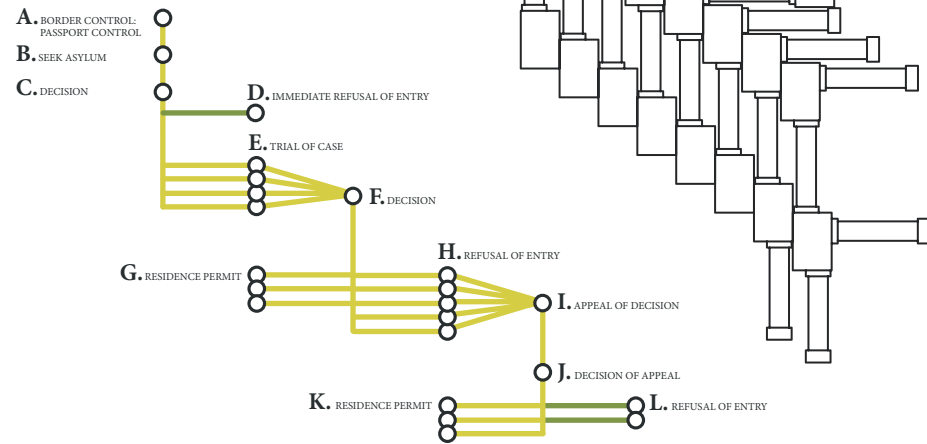

7/10 RESIDENCE PERMIT
3/10 REFUSAL OF ENTRY

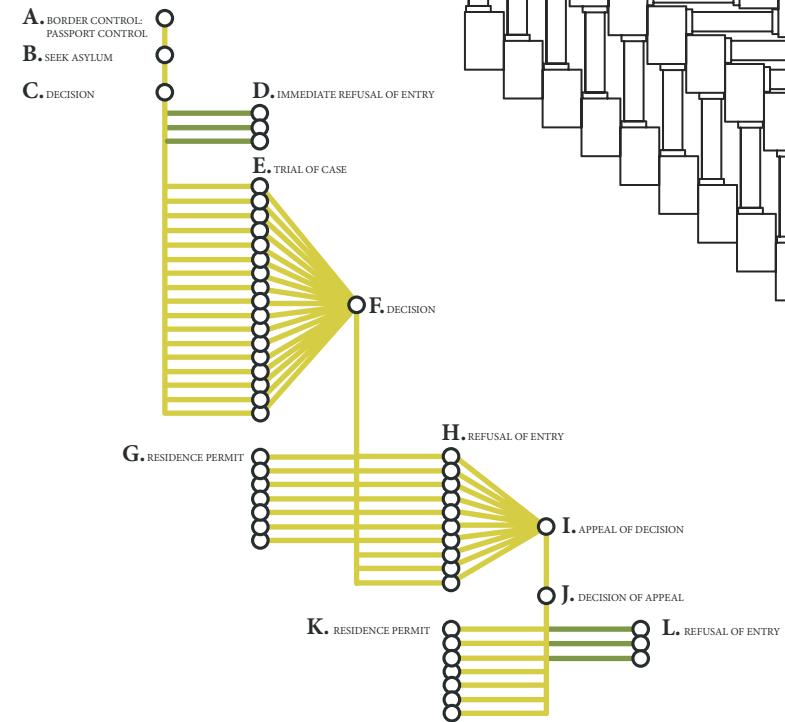

8/10 RESIDENCE PERMIT
2/10 REFUSAL OF ENTRY

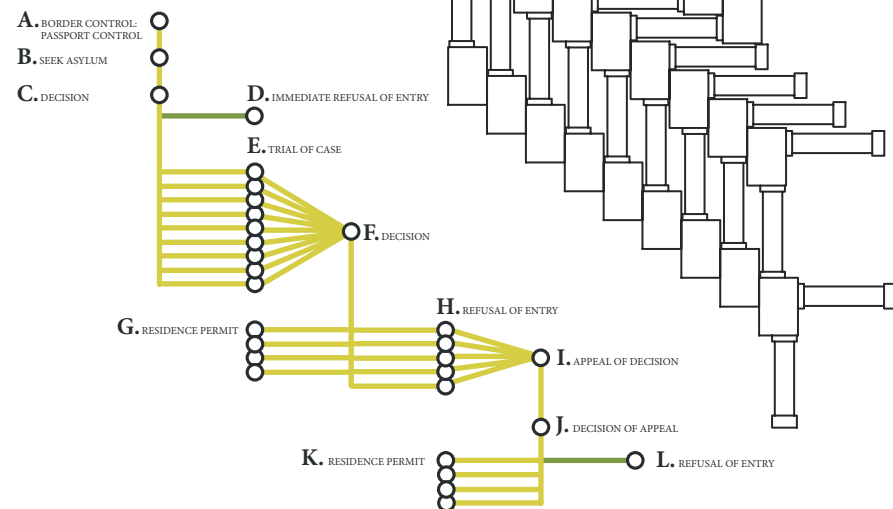

9/10 RESIDENCE PERMIT
1/10 REFUSAL OF ENTRY

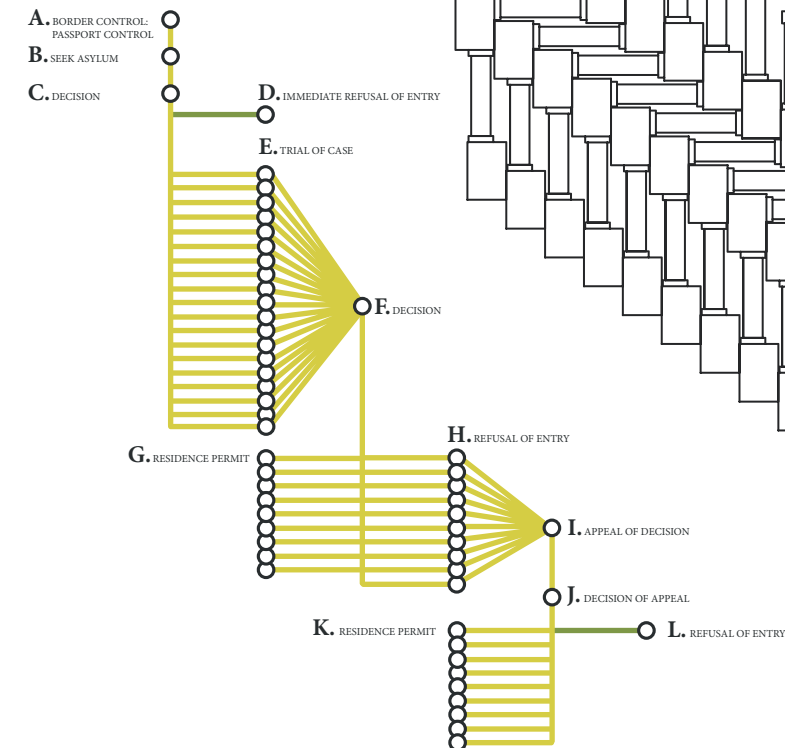

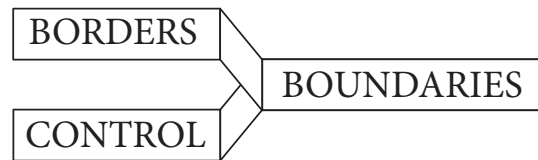

Borders, boundaries and control

Border

1. A part that forms the outer edge of something.
2. A decorative strip around the edge of something, such as fabric.
3. A strip of ground, as at the edge of a garden or walk, in which ornamental plants or shrubs are planted.
4. The line or frontier area separating political divisions or geographic regions; a boundary.

"border." The American Heritage® Dictionary of the English Language, Fourth Edition. Houghton Mifflin Company, 2004. 25 Feb. 2008. <Dictionary.com <http://dictionary.reference.com/browse/border>>.

“Border controls

In recent years EU states have increasingly focused their asylum and migration policies on combating illegal immigration. Visa requirements for nationals coming from refugee producing areas have become more and more strict, while carriers are heavily sanctioned for carrying undocumented passengers to most European countries. This has made it virtually impossible for a person seeking protection to enter the EU through regular channels and driven people to endanger their lives to do so with tragic consequences.

ECRE believes that Europe should set an example in refugee protection. The right to seek asylum is meaningless if people in need of international protection are denied access to EU territory. Erecting ever higher walls is not the solution and a far more balanced approach is needed. ECRE insists that border management must be conducted in full compliance with international human rights obligations, which means ensuring that no asylum seeker is sent back at the border to a risk of persecution.”

(Source: European council of refugees and exiles)

The manifestation of borders in massive walls and barbed wire fences is suggesting that there is an outside threat to be afraid of, there is someone who is going to take something away from us, and the walls and fences are supposed to protect us from these threats; terrorists, war, refugees, smugglers, drugs... The walls and fences are supposed to make us feel safe, but because of how they separate, divide and how every movement through them is strictly controlled they make us feel even more frightened. This is not only applicable for one specific wall and point in history, it is how boundaries and border controls are operated in the world, where one or more nations want to keep certain individuals and groups out of their territories. A massive wall or barbed wire is not only an aggressive way of keeping people out it also creates a hostile ambience among the citizens of the 'protected' area/society/nation/class/ethnic group/gender etc. A society where fear and aggressiveness rules will never be a safe place; what the wall is supposed to protect from is suddenly on the wrong side of the fence, and instead of protecting it has created scared and alienated citizens. Walls are ambiguous and therefore complicated.

“The 1951 Refugee ConventionThe 1951 Convention relating to the Status of Refugees is the key legal document in defining who is a refugee, their rights and the legal obligations of states. The 1967 Protocol removed geographical and temporal restrictions from the Convention.”

(Source: <http://www.unhcr.org/cgi-bin/texis/vtx/protect?id=3c0762ea4>)

The UN describes the Refugee Convention as: “The wall behind which refugee can shelter”, which would be a beautiful wall if it could cross all other walls. It has defined what it should protect from and who it is protecting; shelter from war, persecution etc is a human right according to UN, the only problem is when it is conflicting with other walls, which is very often the case. Nations who have signed the convention tend more and more to neglect the UN refugee convention and therefore violate it. In Europe The implementation of the Schengen Agreement has made it more or less impossible to come as a refugee and seek asylum in a member country of this area, and if you manage to get in it does not assure you anything, except a long bureaucratic process.

The Method

The Park of The Involuntary Tourist is a place that provides information concerning refugees, migration, E.U., The Schengen Agreement etc. Instead of looking for a specific program to design a building around I have designed a structure which can expose the situation of refugees without exploiting them, and let it form my program.

I have identified the obstacles a refugee faces: physical, such as walls and borders, and legislative, such as the asylum process. These have been my design parameters and driving force, as well as to question and recreate the wall, to understand how borders and walls work. These parameters have formed my structure which is not a building but rather a structure to examine an issue. What kind of structure and program does the refugee issue need to be seen, without making an explicit building, such as a museum or an exhibition pavilion?

The structure and the plan

I have transformed the asylum process into a 3d structure, consisting of rectangular metal tubes with the dimensions of a regular container and connecting parts, where every authority of a final decision is made into a choice between one or more possible ways to move in the structure. The asylum process is manipulated to generate different kinds of scenarios and the structure is created from the results of the probability calculus of the asylum process. This is then translated into a 3d structure, which creates 10 different variations built out of containers and connecting parts. The different results are put together to make one big horizontal structure.

I have generated a master plan, which grows over time according to the development of the implementation of the Schengen Agreement in the member states. New parts are added to the structure for as long as the number of

member states of Schengen is growing, and the last plan presented suggests a future scenario, where potential member states are added. Starting on March 3rd 1995, when the Schengen Agreement was first implemented, the first part of the structure divides the Island of Sacca san Mattia in two separate areas: the north west part, where the rigid structure of the asylum process will grow in a non-organized way, and the south east part, where a vastfield will be punctuated with big speakers placed in an orthogonal grid. The result will be a wall, dividing the island into two different areas and separating people who are moving inside it. You will most likely get lost in both the structure and the "red tapeism" of it.

The north west part is made with borders as design parameters: closing, dividing, enclosing, and separating, where the visitor's possibility to move is strictly controlled. If you go out of the structure you will find yourself on the sometimes muddy ground or dry fields of Sacca san Mattia, artificially created as all islands in the Venetian Lagoon. The south east part is designed as an open space, where you can move freely among loud speakers, which are organized according to a rigid grid structure generated out of the dimensions of a container. Here the visitor can wander around listening to refugee's stories broadcast from the speakers.

THE MODULE SYSTEM

THE PROGRAM

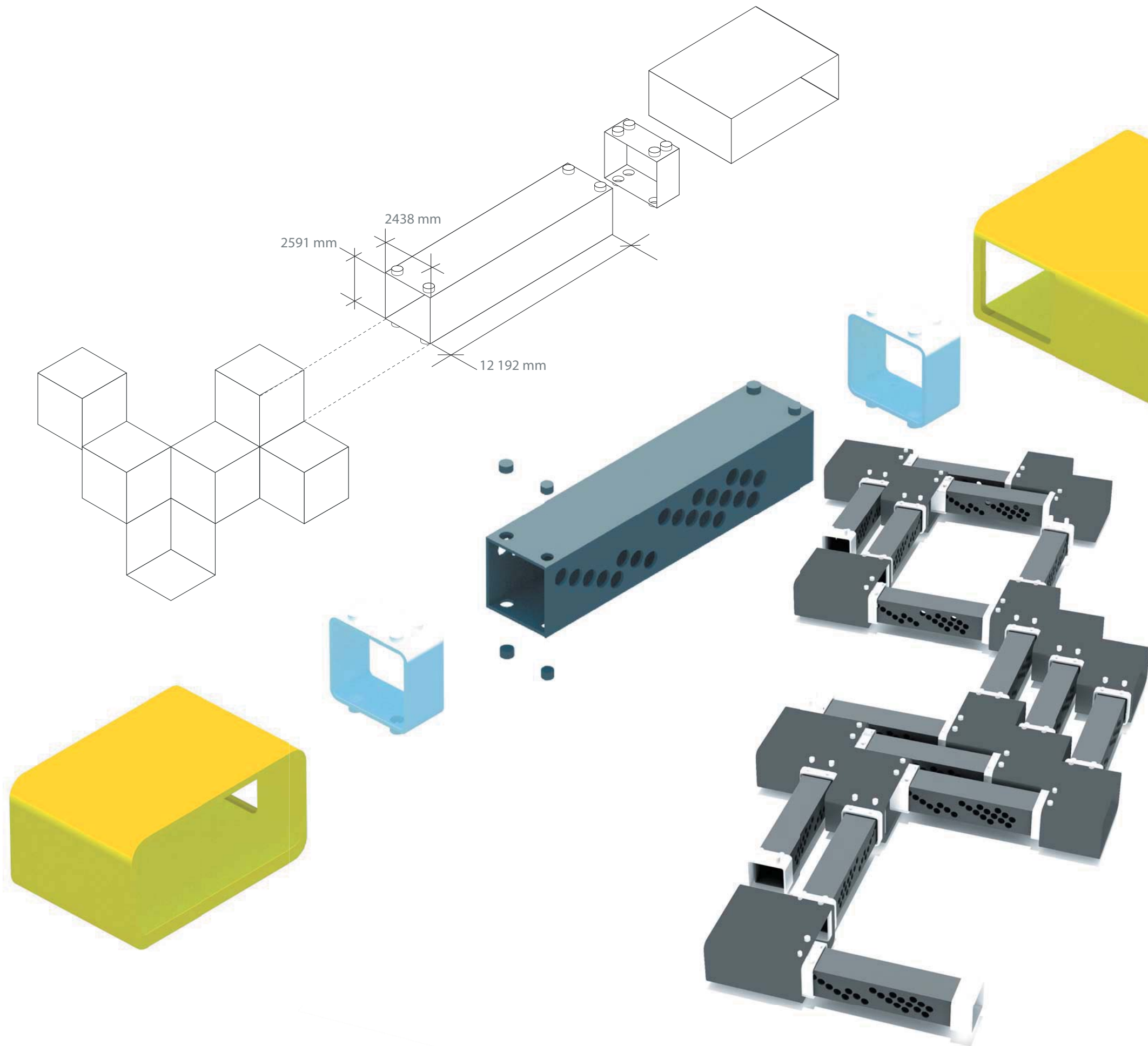

The program

The program educates the visitor about refugees' situations. The connecting parts of the structure work as small information areas, where four different types of media are used to inform the visitor: sound, video, text and manned information desks. At *The Sound Information: Stories from the border*, the visitor can listen to recordings from the border controls along the Schengen border, in *The Video Space: Greetings from the border*, screens show films from surveillance cameras placed at border controls. The manned information desks, *The Lost and Found*, are operated by humanitarian organizations working for refugees and human rights. In *The Reading Space: Reports from the border*, the visitor can borrow books concerning refugee issues, international law, E.U., Schengen Agreement etc. The different media/information spaces are relatively small, 59 m² for the manned info desk and 34 m² for the sound, video and text spaces, but together they occupy quite a large area divided into smaller units.

There is only one entrance to the structure but several exits, where exits represent residence permits and refusals of entry lead to a new asylum process or a dead end. The structure is a metaphor of the asylum process in time and space, with the purpose of educating the visitors, and making the situation of refugees visible without exploiting them. The container is introduced as a symbol for refugees, because it is a common mean of transport for refugees getting smuggled into the E.U and the countries of Schengen, where it is now today more or less impossible to get in without a visa. Whether you get a VISA or not depends on your nationality, and third world countries and countries at war are mostly on the list of non wanted citizens.

Nothing can be bought here and the only thing you can bring with you is the experience of being here, the experience of the vast space or walking in an endless row of containers joined together with the different information spaces, organized in a horizontal structure according to plans generated from the administrative process of the asylum process, which is the battle a refugee has to fight when she or he wants to get into a Schengen Country.

THE MODULE SYSTEM

THE GRID

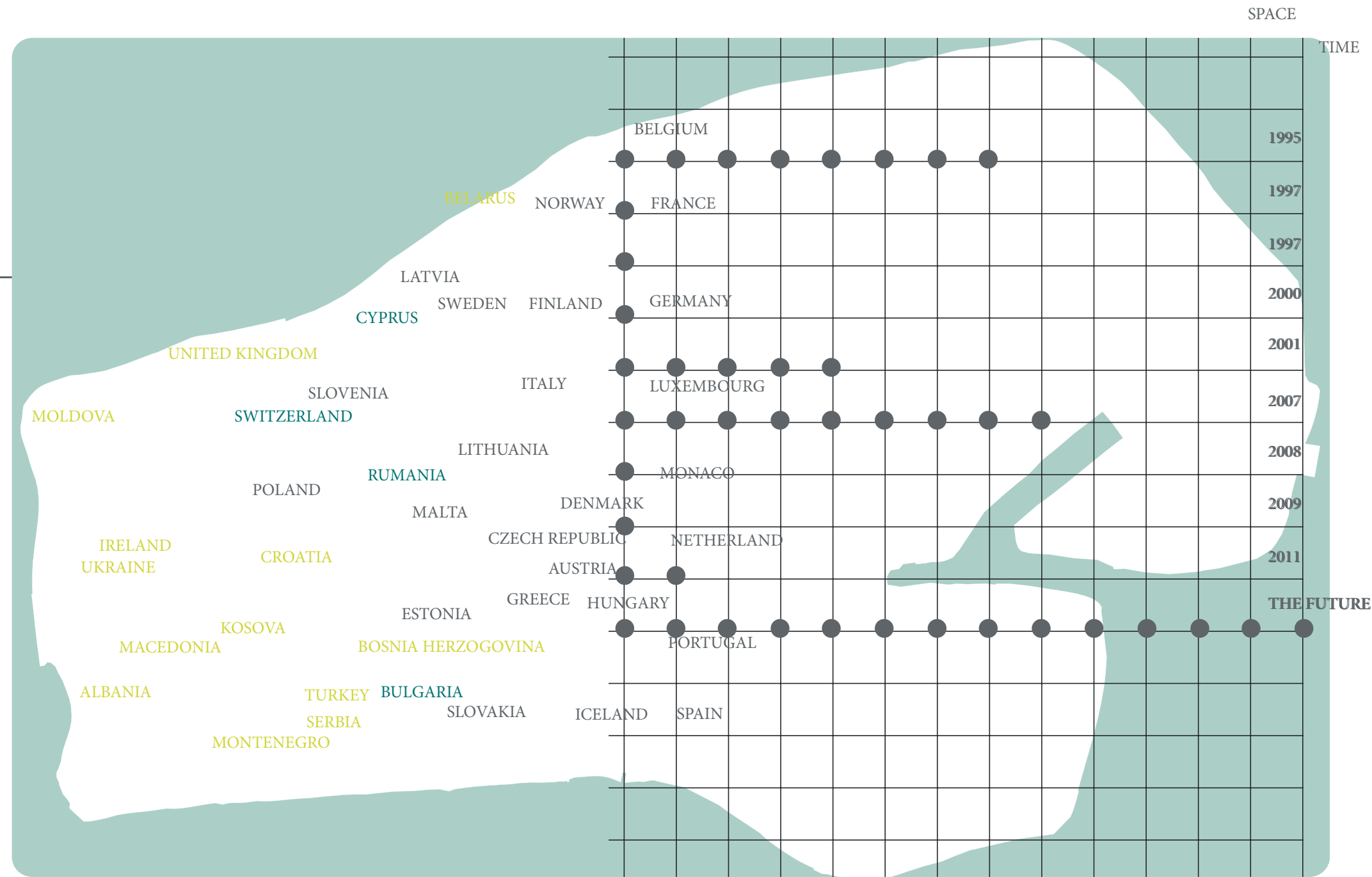
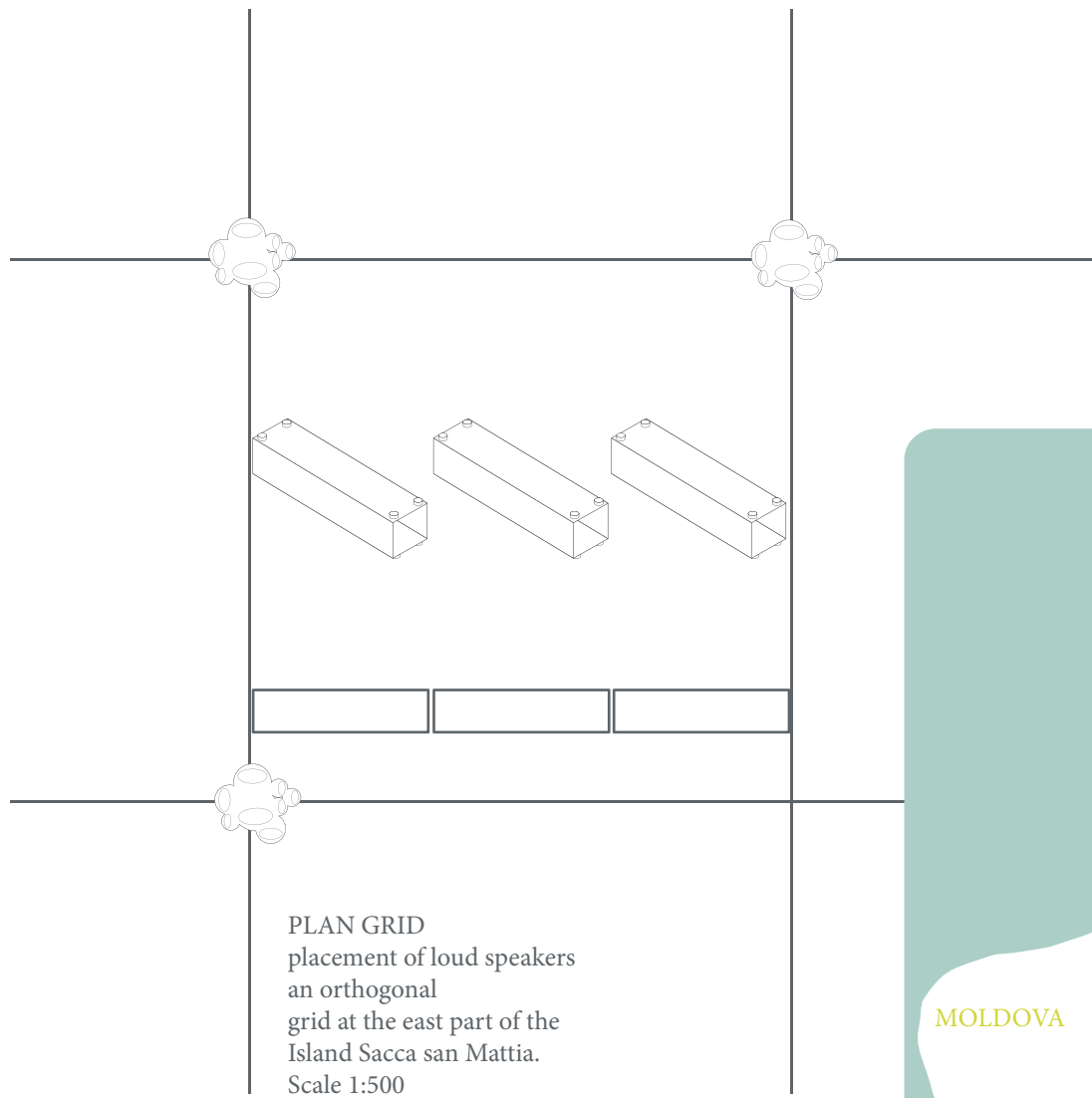

DIAGRAM
Development of the plan in time and space

● Big outdoor speakers

ICELAND= Members of the Schengen Agreement implemented

BULGARIA= Members of the Schengen Agreement to be implemented

MOLDOVA= Potential new member states

3 march 1995

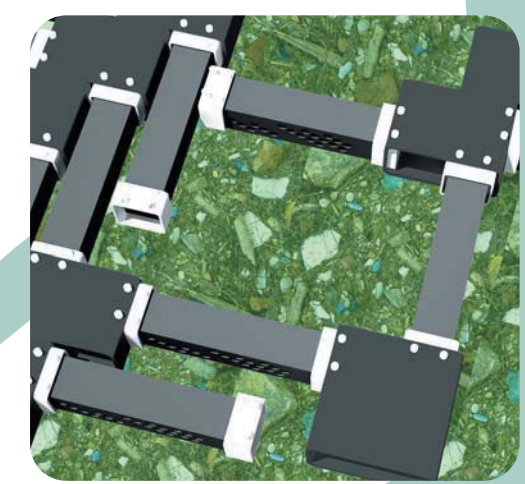
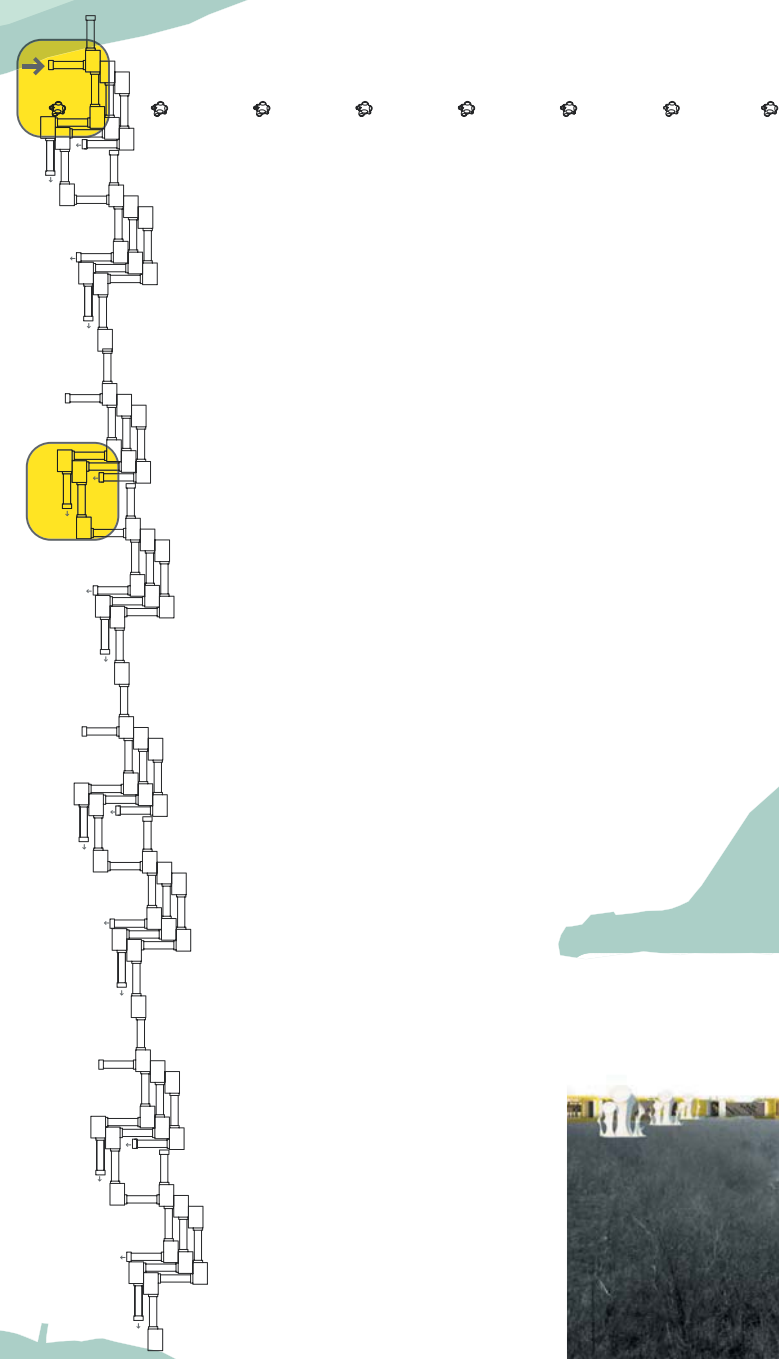



3 March 1995

26 October 1997

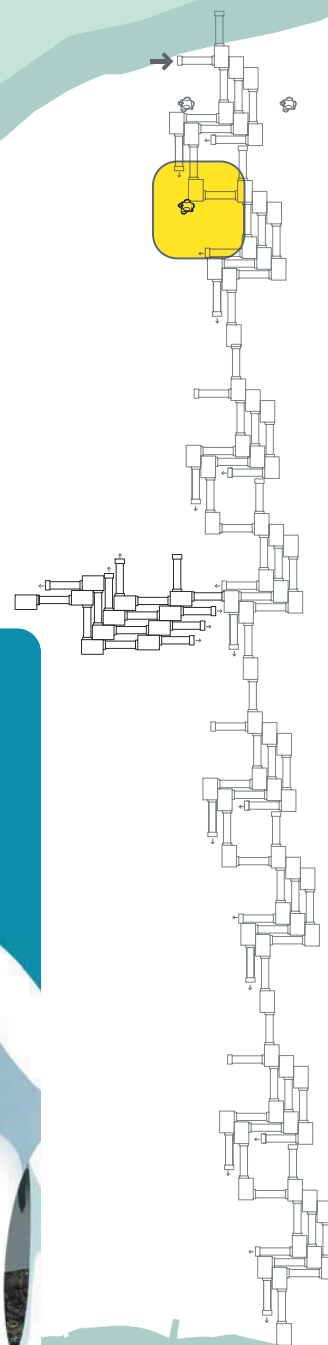
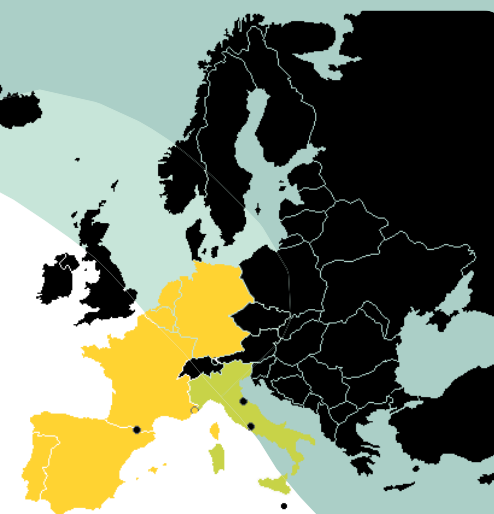

1 December 1997



26 March 2000

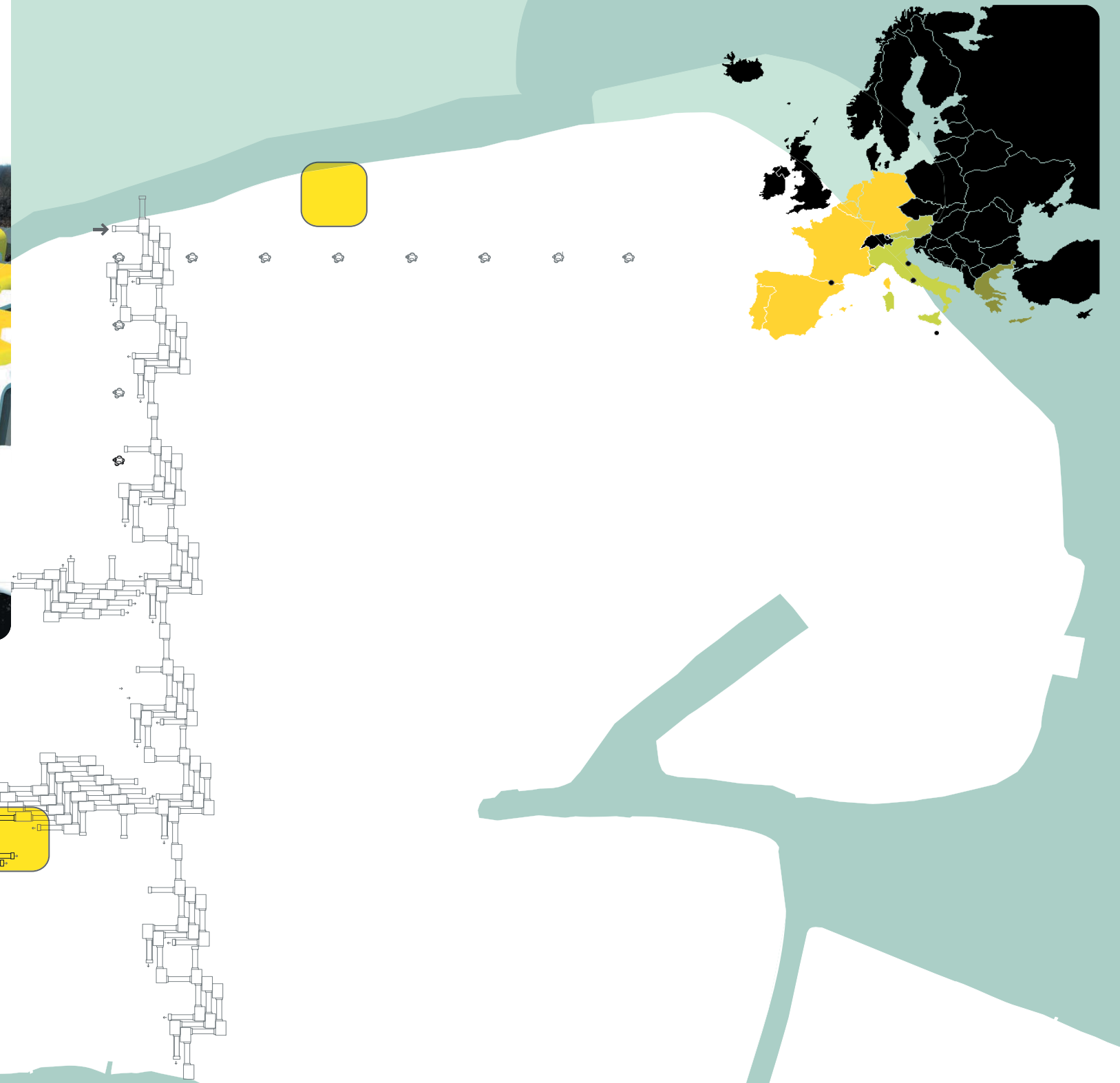

25 march 2001

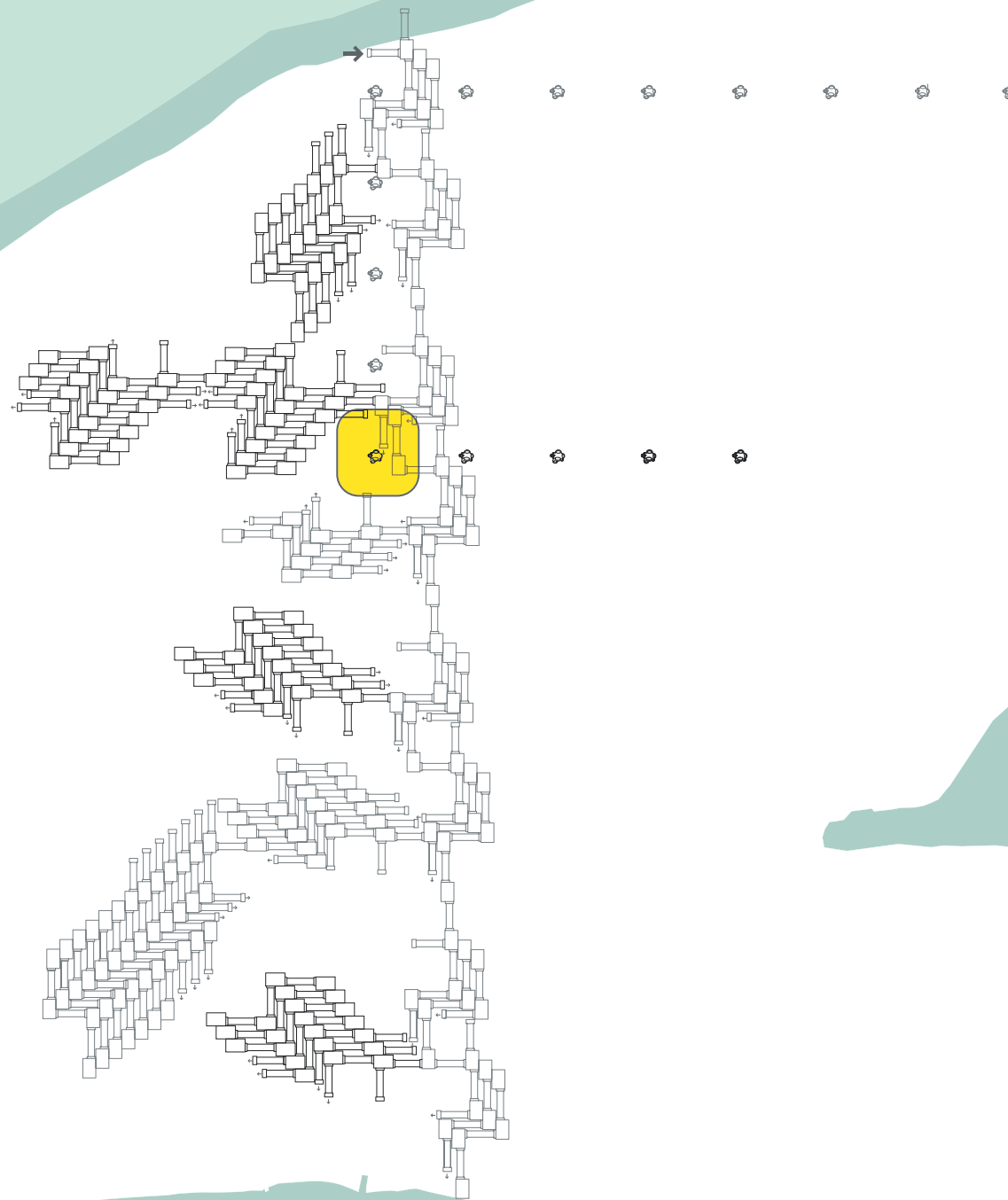
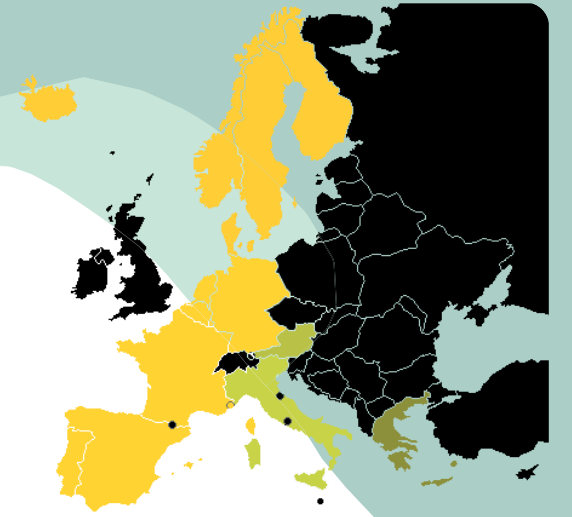



25 March 2001

2007

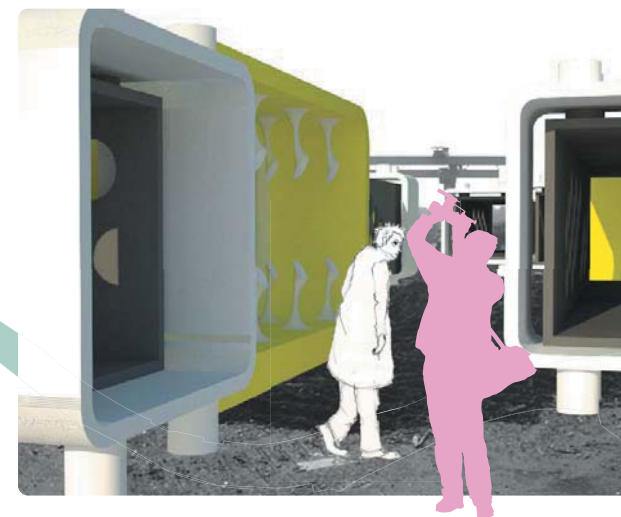
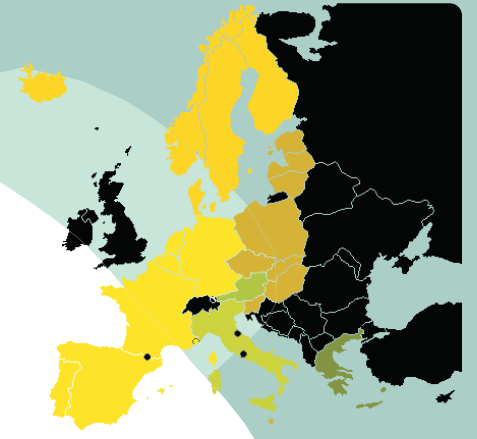

November 2008

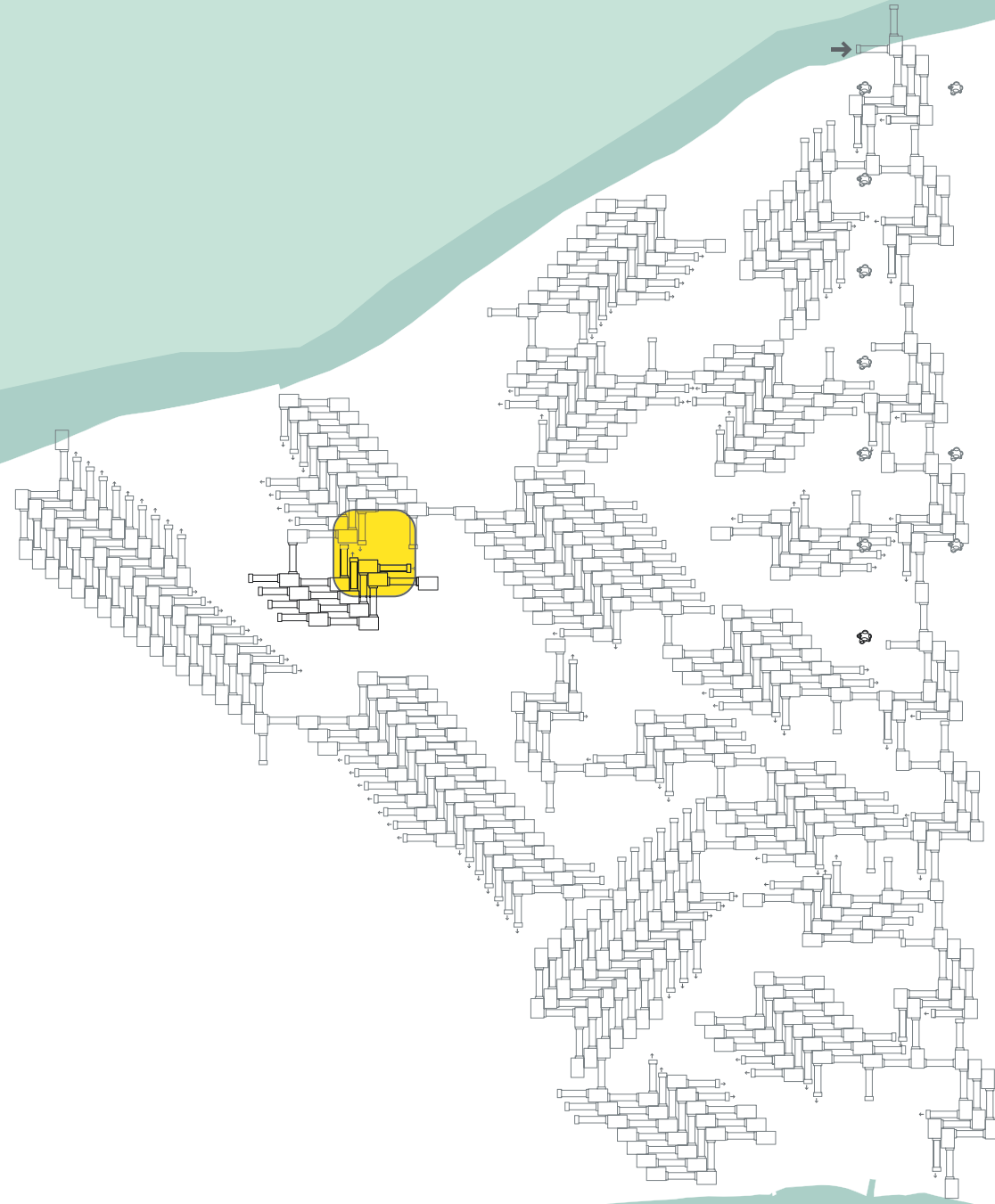
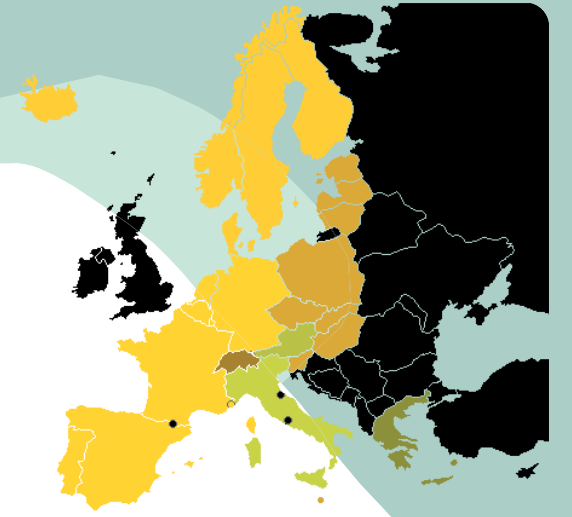

2009

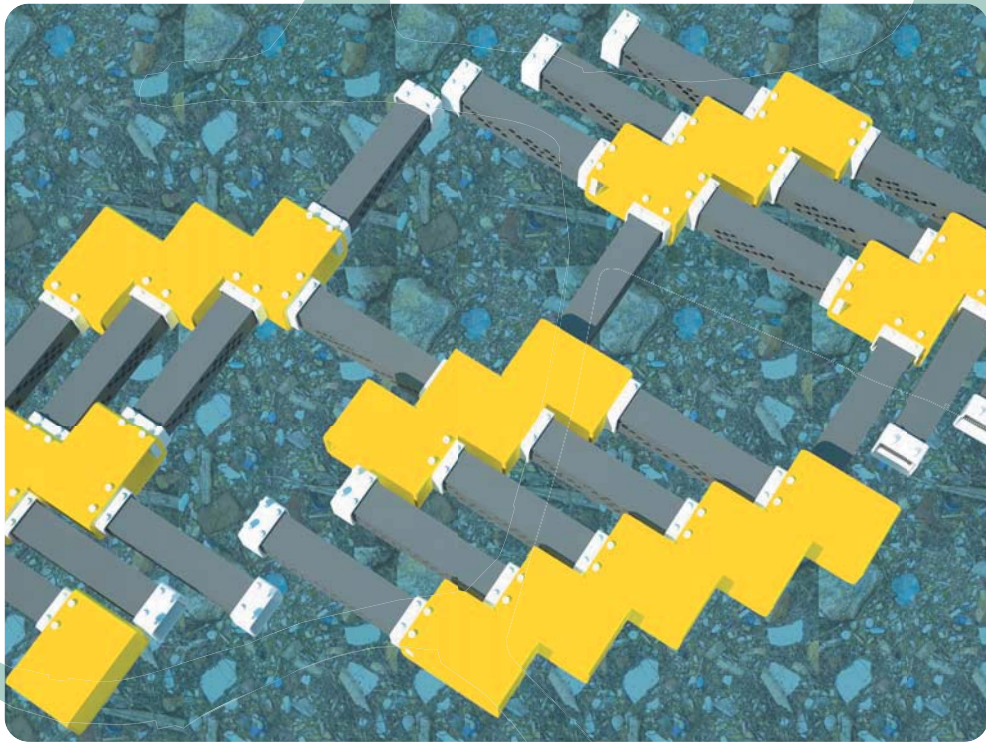
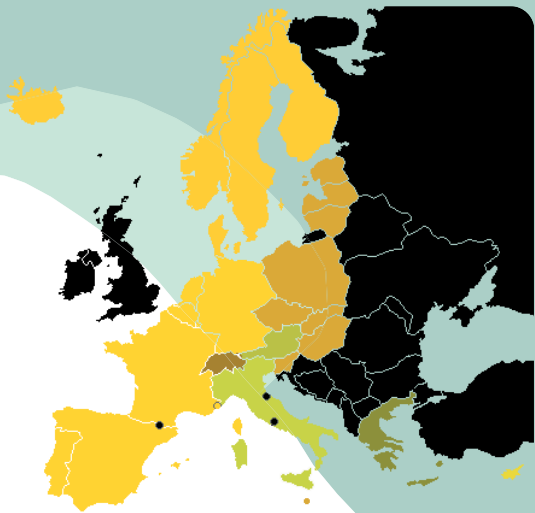
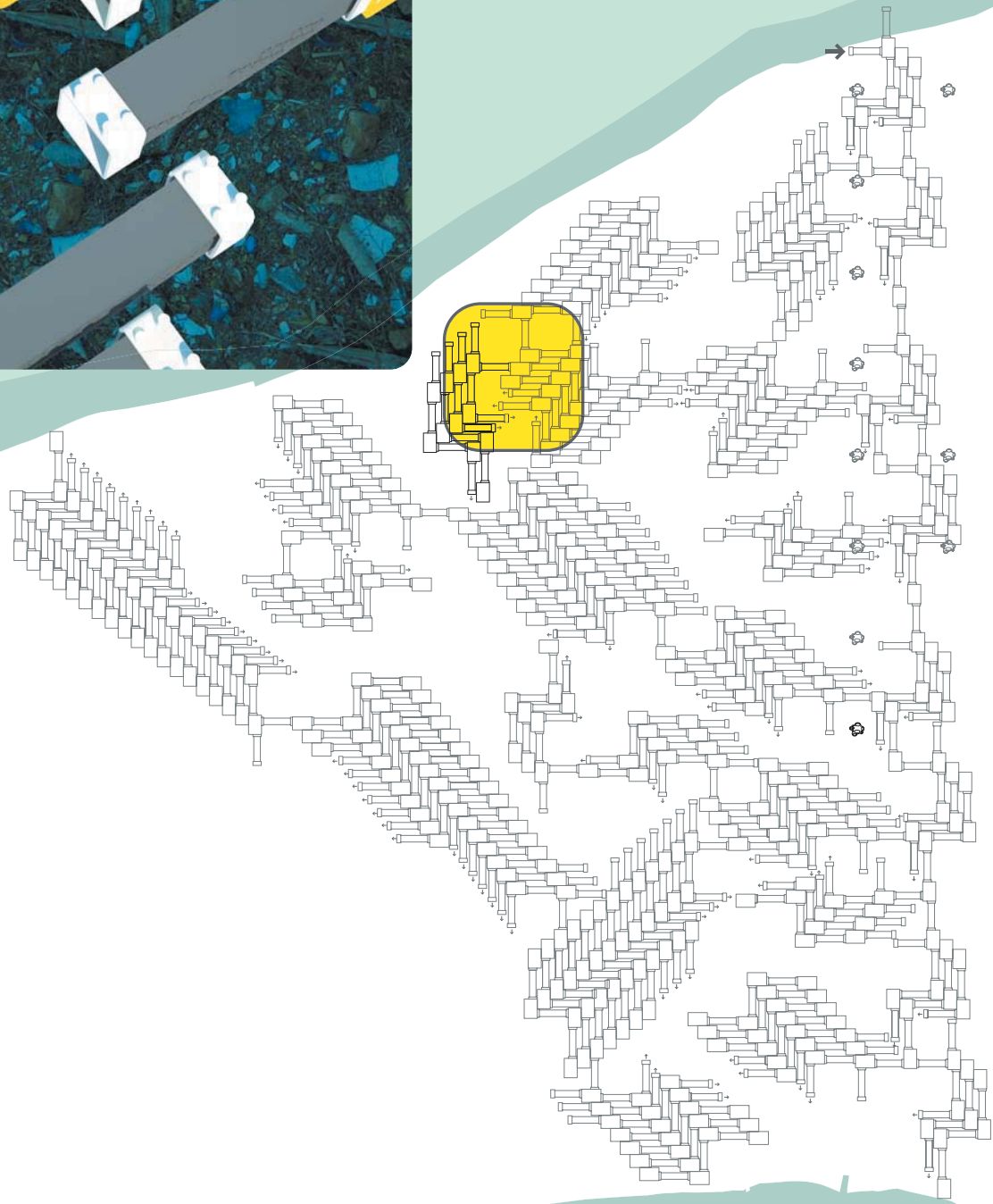
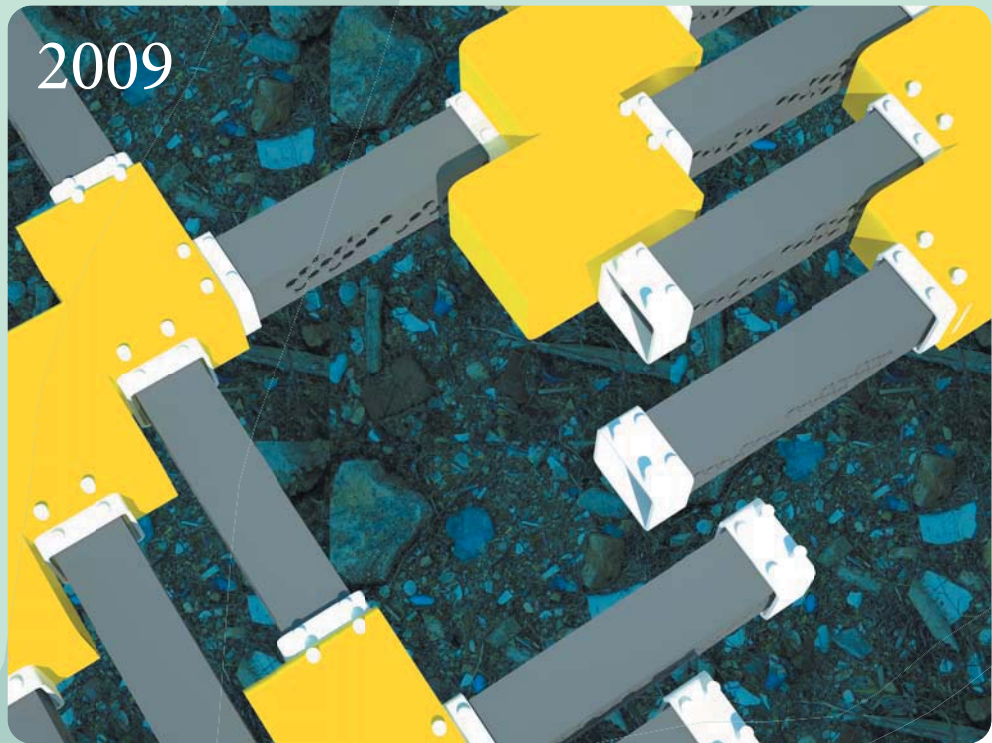

2011

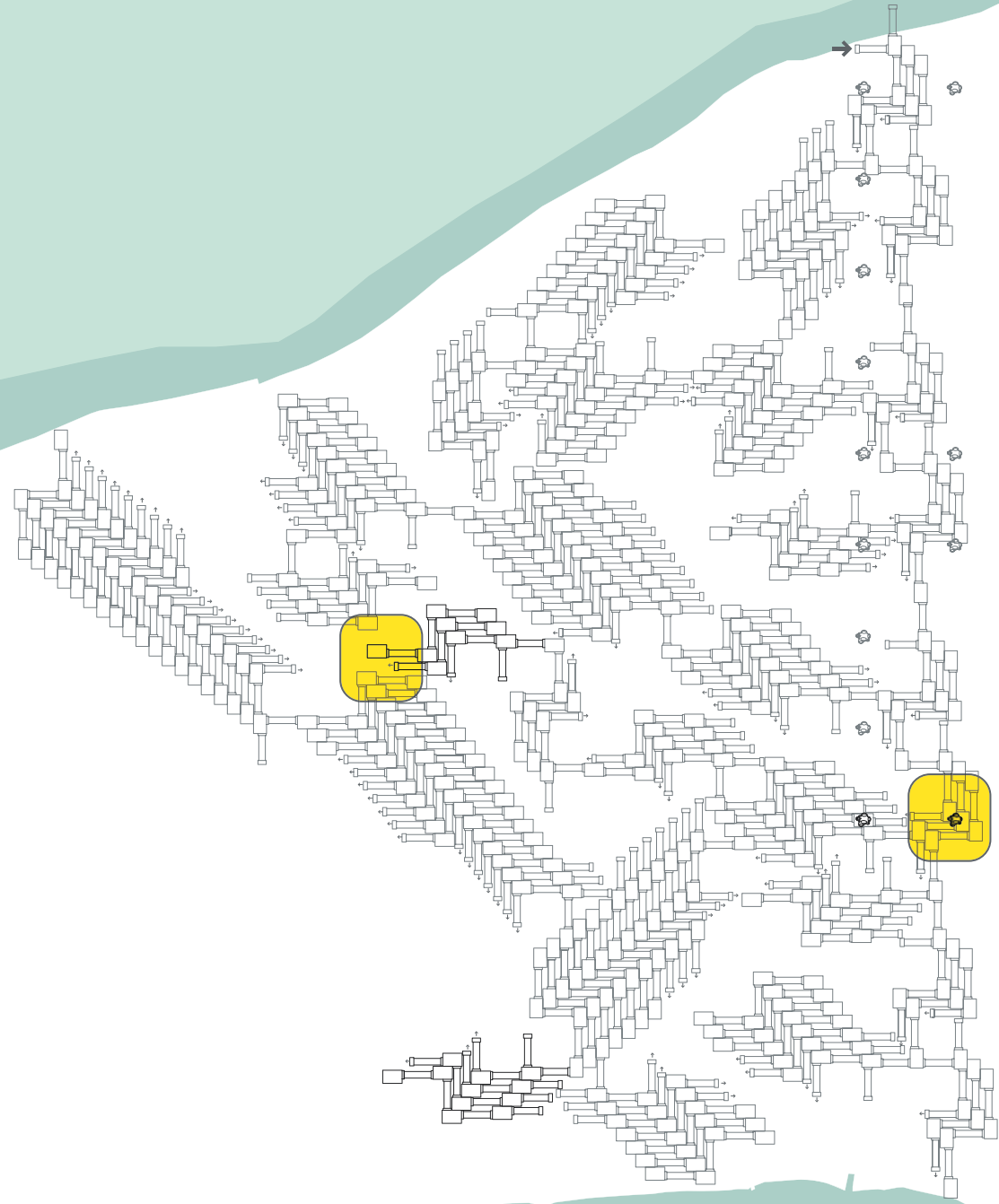
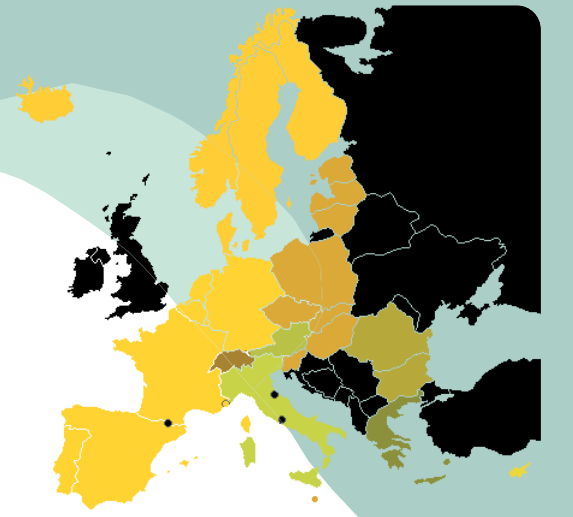

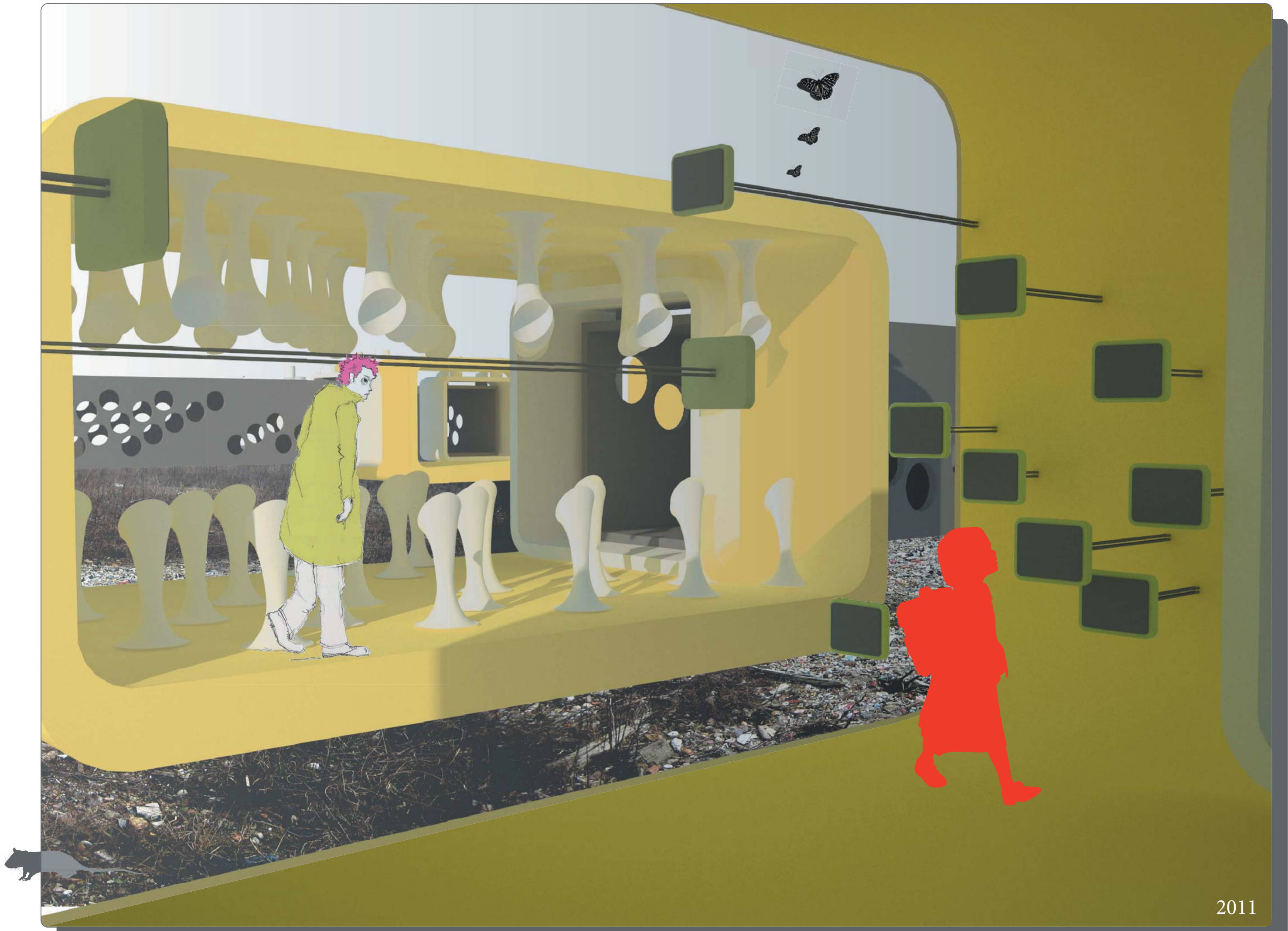

A future scenario

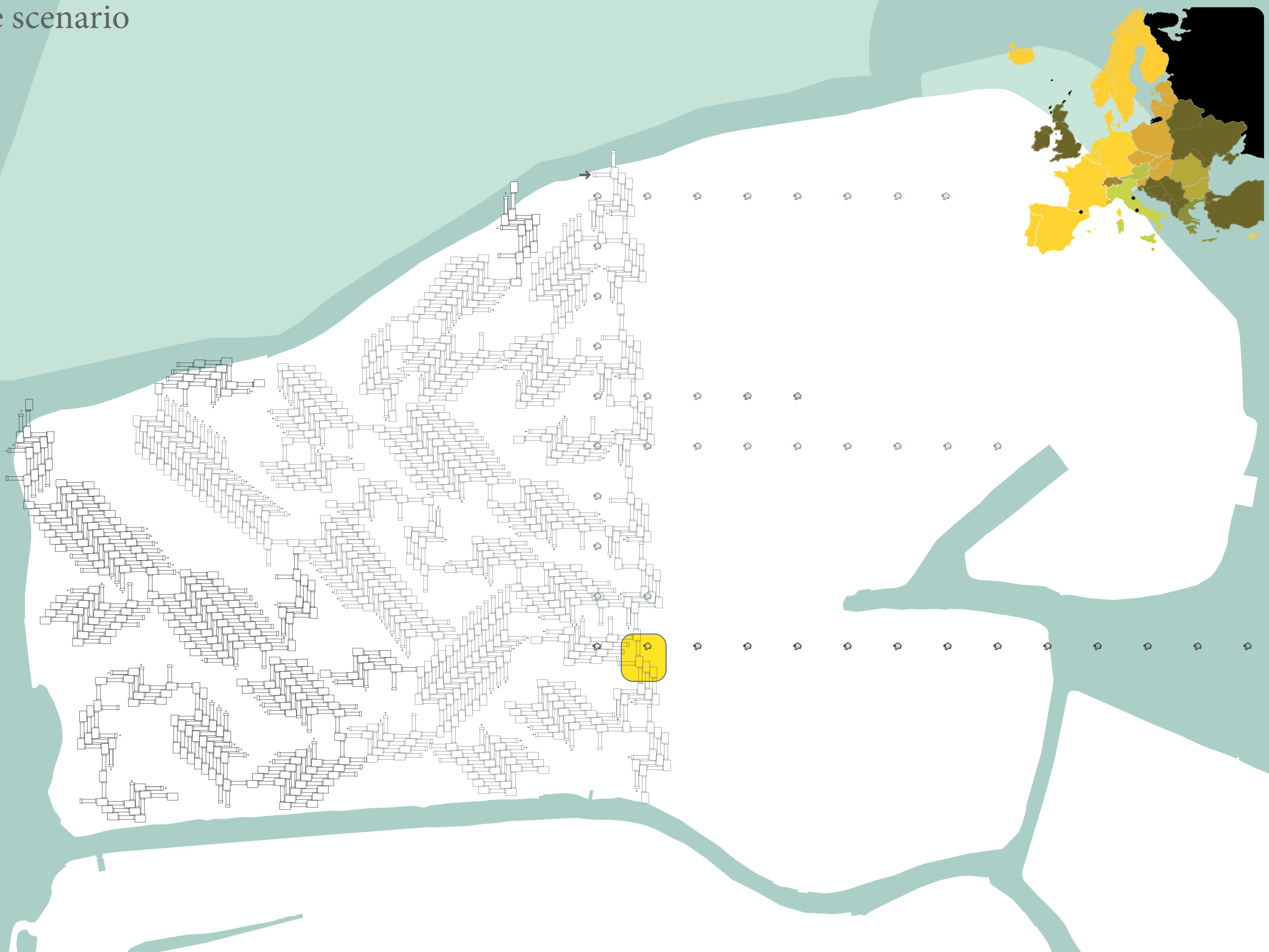



A Future Scenario

THE SPEAKER

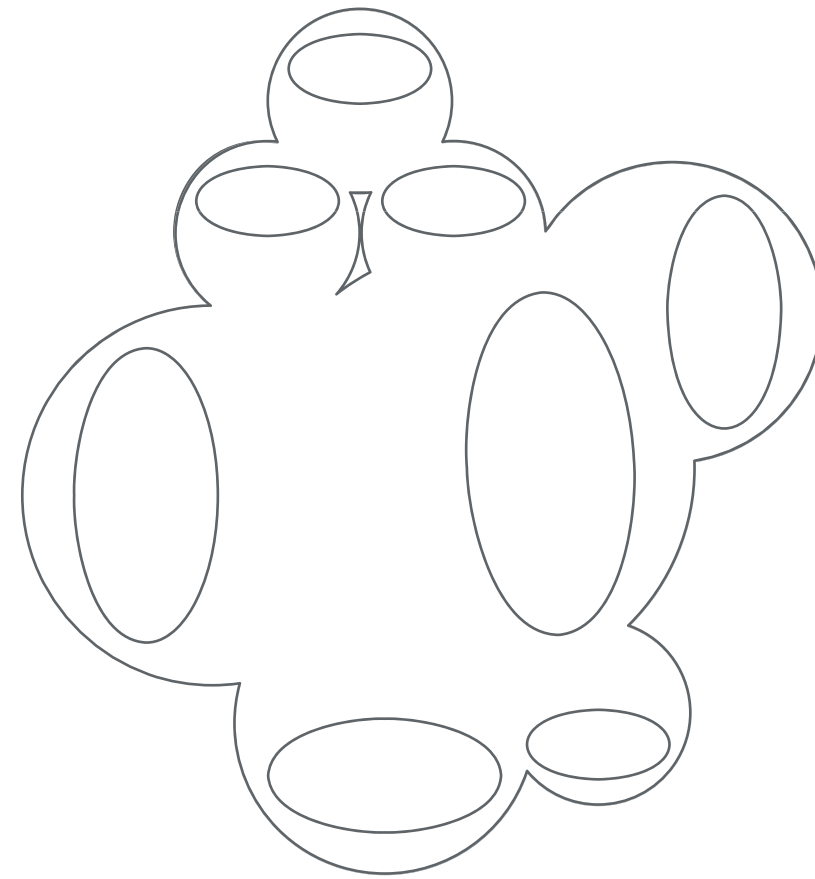
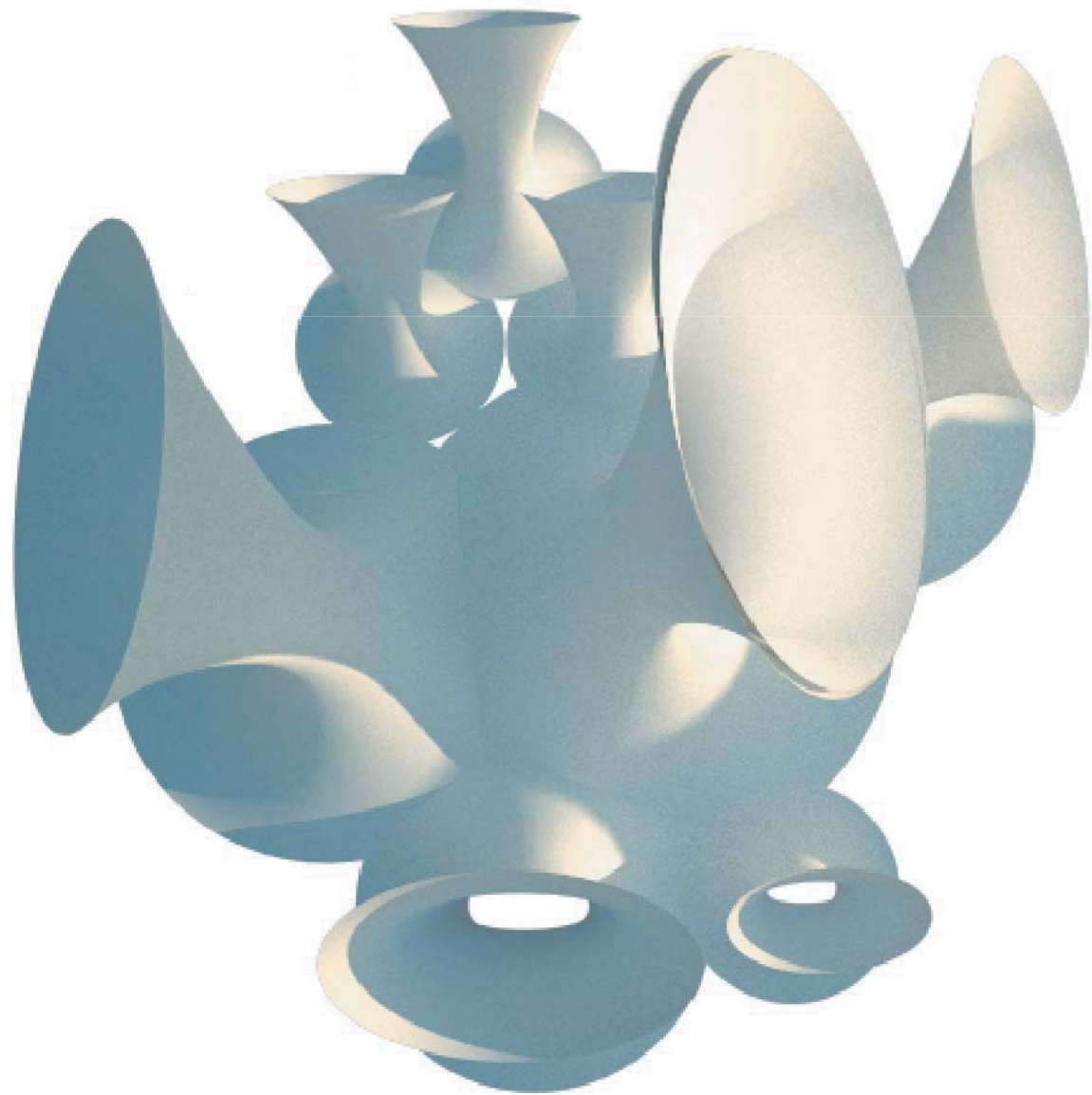
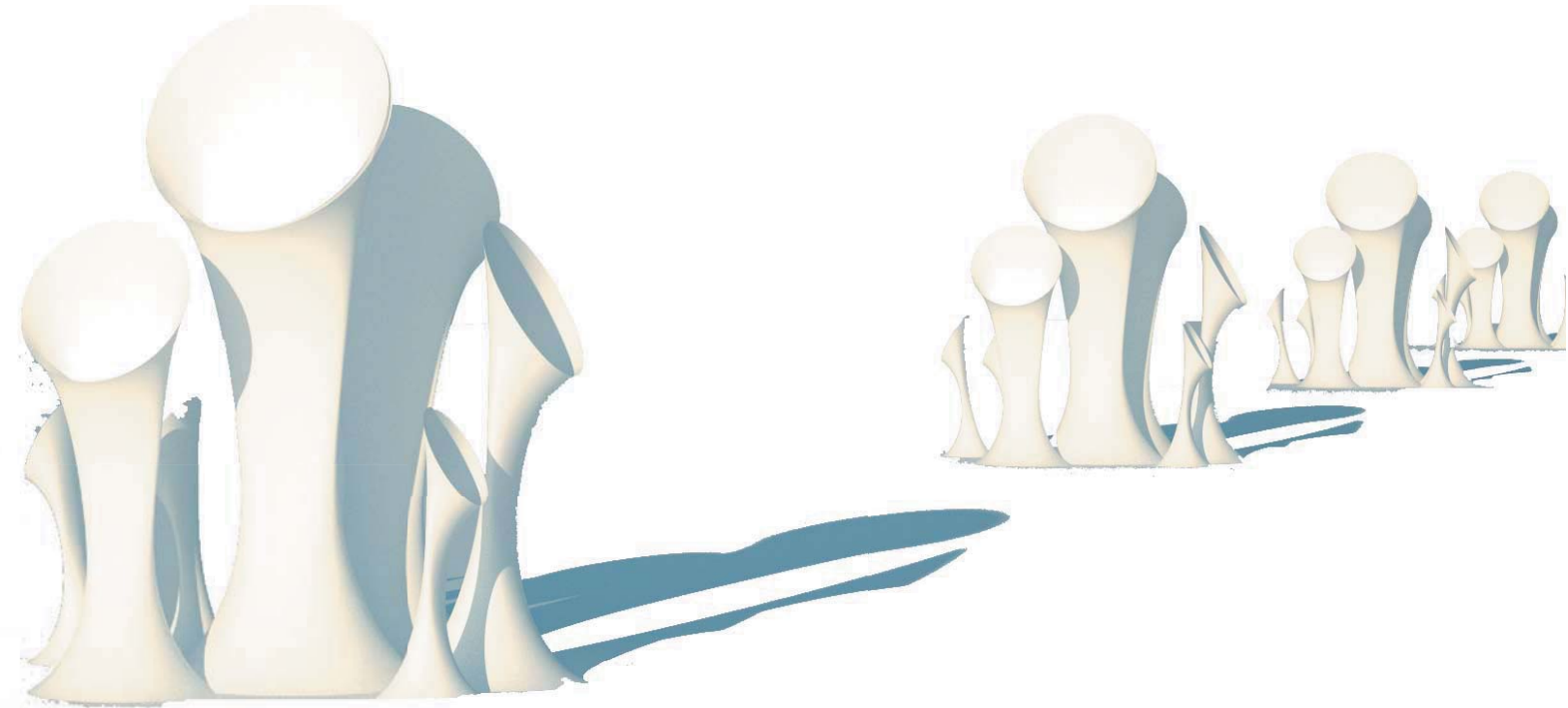

PLAN OUTDOOR SPEAKER
Scale 1:50

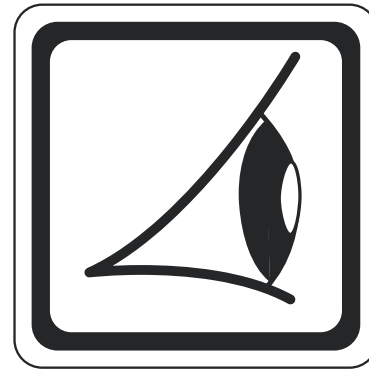
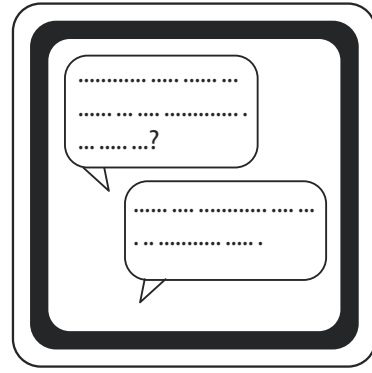

LOST & FOUND

GREETINGS FROM THE BORDER

REPORTS FROM THE BORDER

STORIES FROM THE BORDER

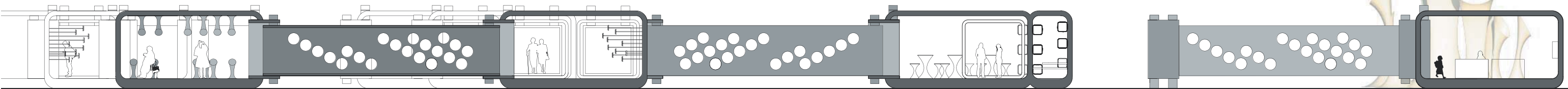
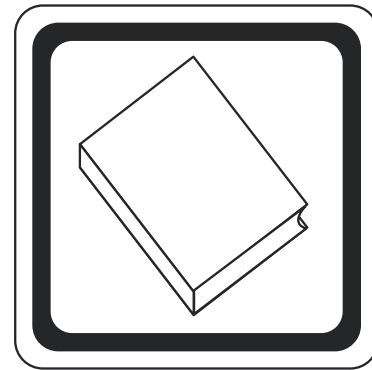

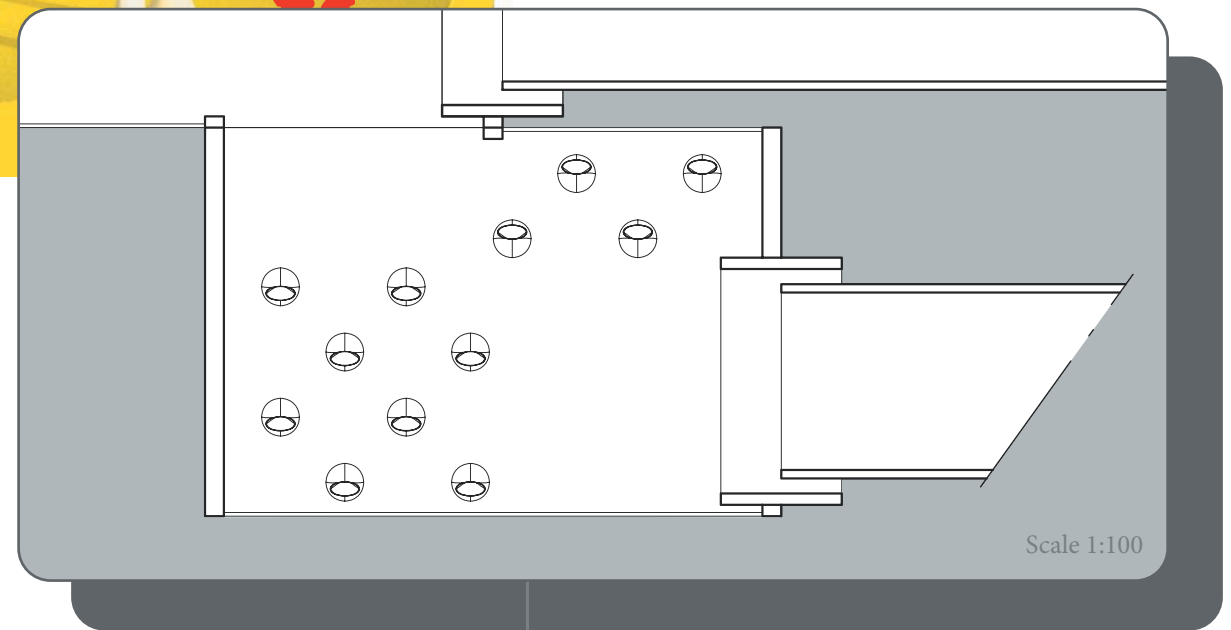

Scale 1:100

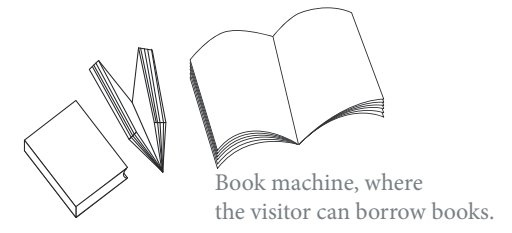
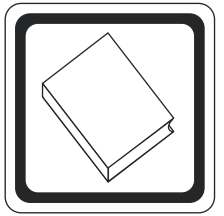

Book machine, where the visitor can borrow books.

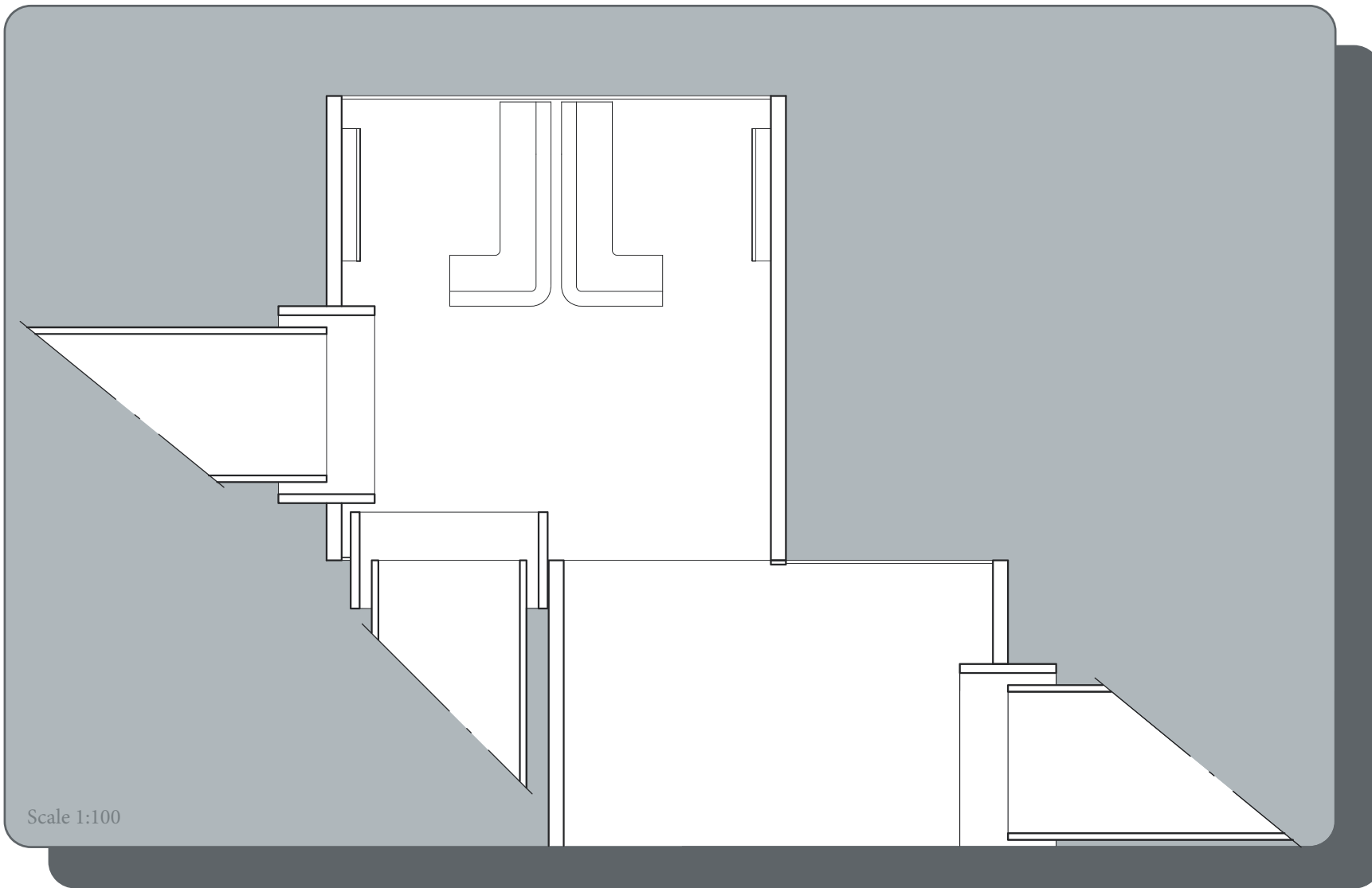
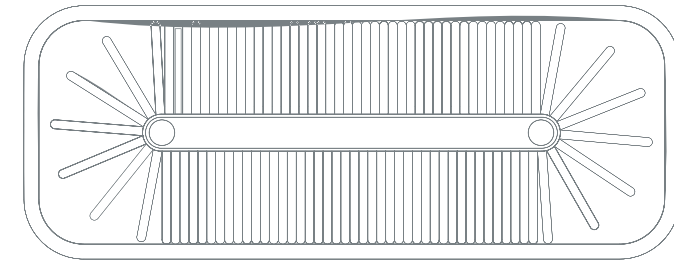

Scale 1:100



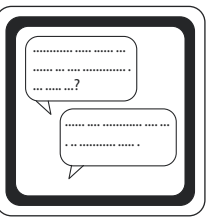
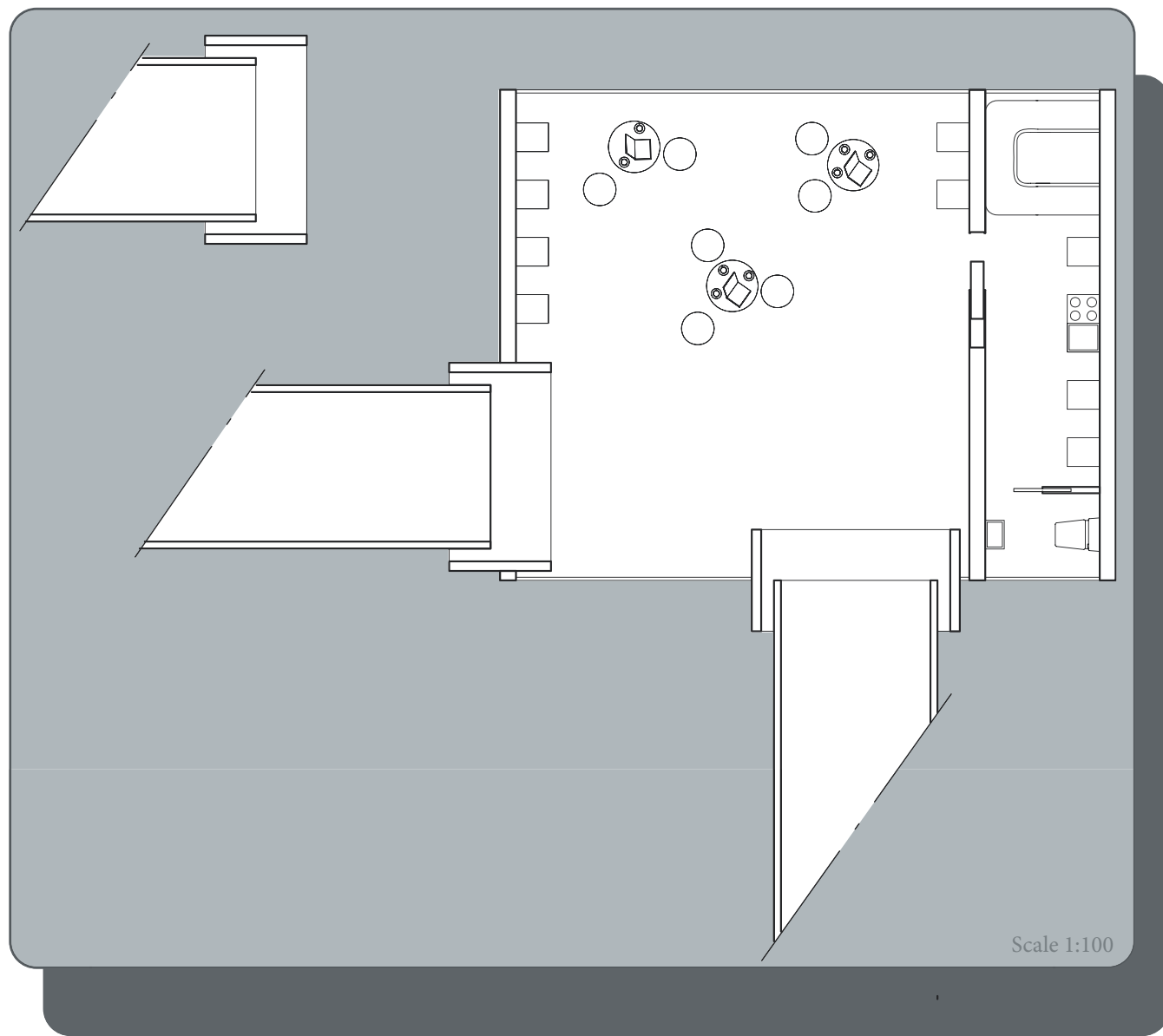

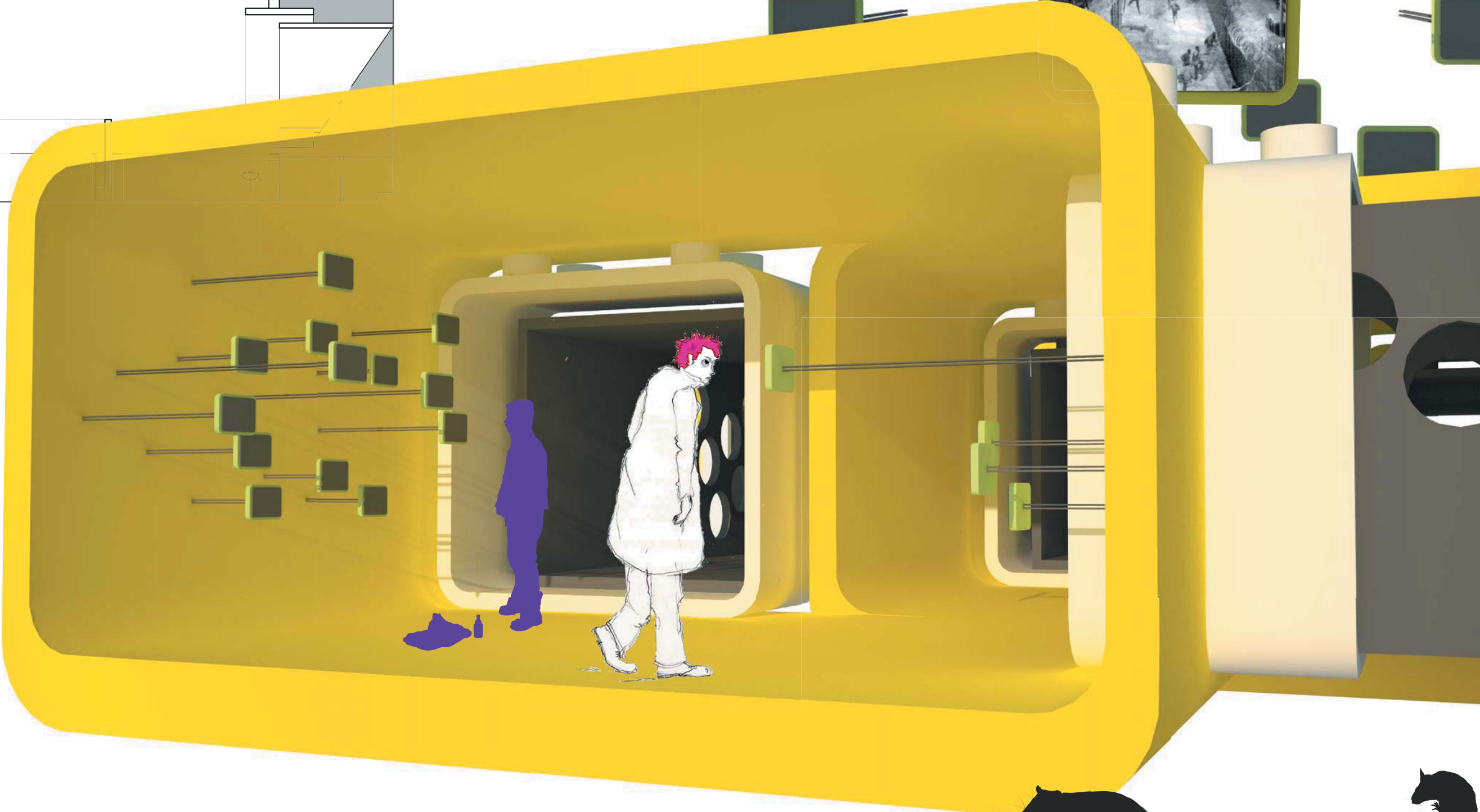
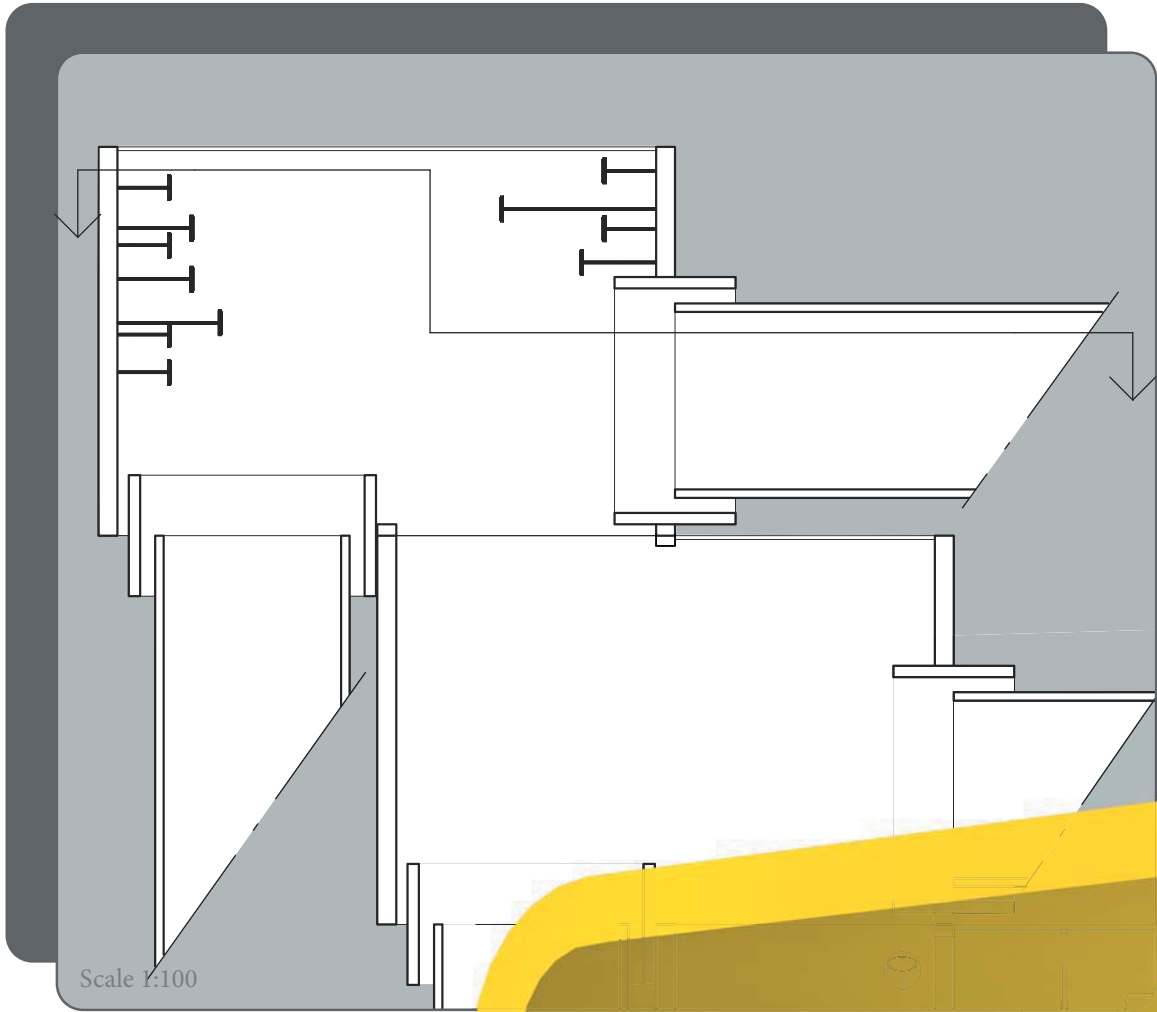
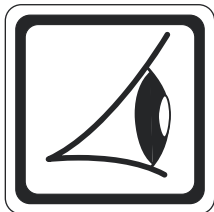



The history of Venice, like that of a lot of cities, is full of inequality, violence, segregation etc, but it is concealed in the romantic notion of Venice. I want to manifest the program, the absurdity and cruelty of the asylum process in a physical structure, and place it in a context with a completely opposite reality, a romantic and touristy place, the Venetian Lagoon, and it is in the contrast between these two realities my project will exist. This is a place where you can be a tourist in another way; consume without materialism and be exposed to another kind of reality.

This is not supposed to be understood as a dystopian project: it is about showing the state of a situation, a very cynical situation, where the refugee is often considered a problem instead of a human being with the same rights as everyone else.

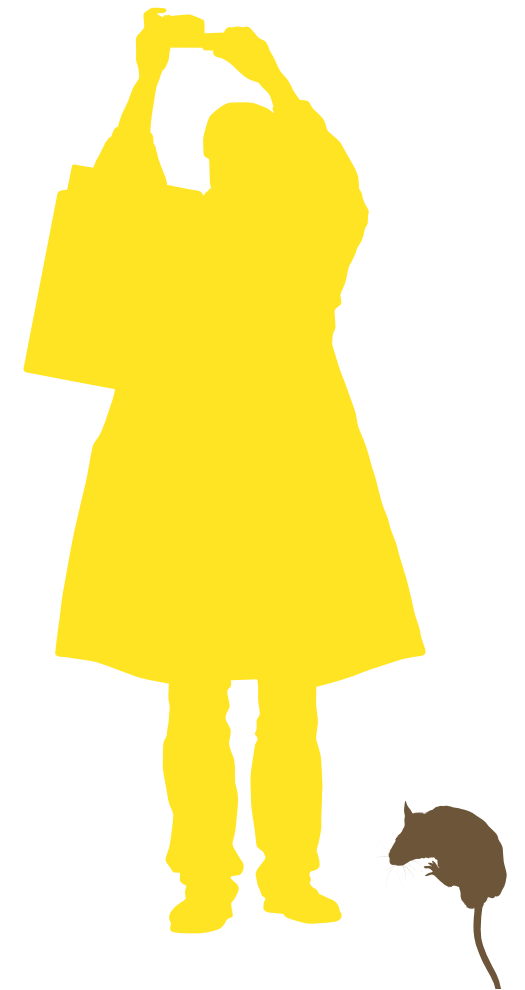
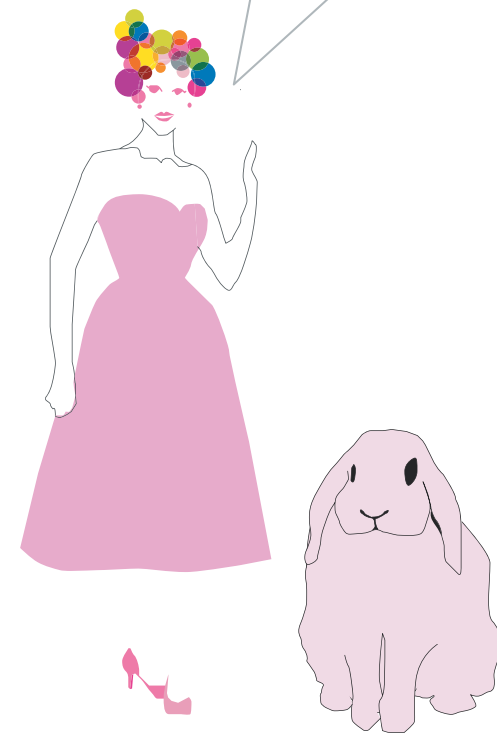

Appendix

1 Definition "Fantasy City":

Six central elements

1. "theme-o-centric": everything about the city is "conformed to a scripted theme"; sports, history, popular entertainment, and "an ambience is created around a distinctive geographic locale, historical period or type of culture activity."
2. "aggressively branded"; "Urban entertainment destinations are not financed and marketed exclusively on the basis of their ability to deliver a high degree of consumer satisfaction and fun but also on their potential for selling licensed merchandise on site."
3. 24/7 open hours
4. "modular"; it consists of a "standard array of components" which are mixed and matched together.
5. "solipsistic; isolated from surrounding neighbourhoods physically, economically, and culturally." Ignoring the reality and any sort of social problems.
6. "postmodern insomuch as it is constructed around technologies of simulation, virtual reality and the thrill of the spectacle." (Hannigan 3-4:1999)

Competition program

"THE VENICE LAGOON PARK PROGRAMME

This second instalment of the 2G competition proposes developing the Venice Lagoon Park project in order to rehabilitate the urban idea of the lagoon as a complex network of communications and settlements, through a hypothetical re-colonisation of the territory of the lagoon, the decentralisation and atomisation of a programme of uses, and the rehabilitation of the idea of the lagoon as an urban constellation necessarily integrated in its natural environment. The proposed Venice Lagoon Park programme will have to have: an Urban Park and Lagoon Prototypes.

3.1. The Urban Park

The Urban Park will be the entrance to the Venice Lagoon Park. A second urban void after Saint Mark's Square, it will accommodate new uses suited to its size, with the aim of becoming a new linking space for the inhabitant of the lagoon and a new entrance area for re-understanding the insertion of Venice in the Lagoon.

The urban park is situated on an 31-hectare island known as Sacca San Mattia, to the north of Murano, an island without a specific use right now which has served as a dump for the waste from glass-making and for building materials from works in the historic centre or on other islands.

The geographical location of the competition island makes the hypothesis feasible of a direct connection to Marco Polo Airport. Today, the regular public transport line connects the airport with the Murano-Colonna stop, to the south of the islands of Murano. A new access is proposed on Sacca San Mattia island which would open up new ways of connecting the islands.

The park's programme is:
landing stage

a visitor's reception and information centre about refugees for refugees (about the lagoon)
concept: a centre with reception, information and orientation services for refugees (visitors) to the lagoon as appoint of welcome, meeting and for redirecting refugees (visitors) to points of interests.

Potential areas:

- a.entrance lobby, information area and various services
- b.left luggage: a space devoted to (visitors' baggage).
- c.A space for independent, individual consultation about (the region). It will have a (list of books, information panels, racks with brochures and maps, as well as facilitate for WiFi areas and computers).
- d.A multi-use hall for (exhibitions, presentations, children's activities, etc)
- e.A bar-cafeteria and restaurant
- f.A shop for (the sale of publications, natural foodstuff (?), gifts etc).
- g.(A general storage)
- h.An office area, including boardrooms, 2 meeting rooms, a cloakroom area with ticket office, a relaxation are for personnel and a storeroom).
- i.(A boat rental point).
- j.(A sports and leisure area)
- k.(A space foreseen for performances)"

(...)=The proposed function in the competition brief

"3.2. Lagoon Prototypes

The Lagoon Prototypes are elements of urban furniture that facilitate new uses in the Venice Lagoon Park and a new way of reconnoitring and understanding it anew. In the premises of the competition the fixed sitting of these is therefore not proposed, the visitor thus becoming the thinking subject of his or her own journey. On the other hand, the idea of prototypes is presented with a deliberate lack of definition in order to encourage entrants to reflect upon the nature of these prototypes, now in order to limit themselves to the design of autonomous objects, now so as to integrate these in a wider urban system of new uses. Although an advisory list of basic prototypes is provided below, this list is open to the incorporation of new elements integrated within the system each project creates:

1. A Refuge. Individual or collective. Temporary stays, maximum 3 nights. The concept of a refuge and the basic needs it must cover are open.
2. An Observatory. Individual or collective, for the observation of fauna, flora, the heavens, etc.
3. A Landing Stage.
4. Energy Way Stations. These may be considered as backup elements for the rest of the prototypes or as autonomous energy-storage stations.
- 5.A Signposting System. Weather information, tide times, addresses of interest, "you are here" information, etc."

(source: the 2G Competition Brief)

- CEMETERY ISLAND
- GLASS ISLAND
- LEISURE ISLAND
- PLEASURE ISLAND

REFUGEE ISLAND

The Park of the Involuntary Tourist

Refugee Island (Succa San Maria), Glass Island (Murano), Cemetery Island, Pleasure Island (Venice), Leisure Island (Lido)
 "The 1951 Refugee Convention"

The 1951 Convention relating to the Status of Refugees is the key legal document in defining who is a refugee, their rights and the legal obligations of states. The 1967 Protocol removed geographical and temporal restrictions from the Convention. In July 2001, UNHCR published a special edition of its Refugees Magazine dedicated to the 50th Anniversary of the Convention. "where it is described as "The wall behind which refugees can shelter". (source: http://www.unhcr.org/refugees/50th/50th.html)

X. The End: Entrance to the Park
 "The end of the escape. Location in the water path between the airport and Succa San Maria creating the Refuge Island to the south."

Y. The Asylum Factory: The Wall which protects rather than excludes people in need.
 The Asylum Factory is a visitor centre for the involuntary tourist, creating a wall on Succa San Maria which stretches out into the water, crossing The Glass Island (Murano) to the north and creating the Refuge Island to the south.
 The Asylum Factory has four different action functions: "The Beginnings" which satisfy the needs of an involuntary tourist, as well as a fifth function, "The Dice".

Y1 The Beginning: The Citizenship
 Recording citizenship without a citizenship you have no rights, you are not allowed to work, get health care etc. Getting a citizenship in an E.U. country is today, a very complicated, long bureaucratic, and often impossible process.

Y2 The Beginning: the finding
 The finding of family and friends.

Y3 The Beginning: the reunion
 The reunion with family and friends.

Y4 The Beginning: the story
 To tell your story and make your voice heard to exist and become visible as a human being. If there is no space for refugees to tell their stories the rest of the world can pretend they do not exist.

Z. The Dice
 The dice, the resting spaces, are the prototypes, extracted from the wall creating holes. Each one symbolizes a person known to be dead or missing in the Adriatic Sea, between the years of 1990 and 2004.

Why?

About 50 million people are refugees in the world right now, according to Amnesty International. This is a critical counterpart to tourism often based on romanticism created out of fabrication of history, colonialism and consumption, which has turned and is transforming places, cities, and countries into glorified scenes of the coloniser's romantic dream, and instant pleasures, without regard towards the inhabitants. Venice, as many other tourist destinations, is more or less completely dependent on tourism, instead of real functions to create an urbanism and an identity around it. If the city is there only to satisfy a market of tourism, the urban structure will be designed around it, which eventually can turn it into nothing more than a superficial spectacle, and to what extent will it in the end differ from fabricated and artificial places such as Disney World?

"Venice is anchored to its history which began with the decline of the Roman Empire of the West and the barbaric invasions. The barbarians, bringing destruction to the inhabited sections of the land, forced many populations to seek refuge on the numerous islands of the lagoon." (Source: All Venice in 14 color photographs by Eugenio Piccini)

Being a refugee is a particular kind of tourism, an involuntary tourism, but as a refugee you are invisible to the world. Refugees are kept outside of borders or locked up in camps. I want to expose them and place them where people are, as a comment on how refugees are treated and locked away. This is not about solving the refugee issue, it is about raising the question.

Borders

This is a recording of the past, where every heart represents a person, lost in the Adriatic Sea, while trying to cross the E.U. borders.
 ♥ Known missing refugee in the Adriatic Sea.
 ♥ Dead refugee found in the Adriatic Sea.



Y. The Asylum Factory
 Diagram of plan

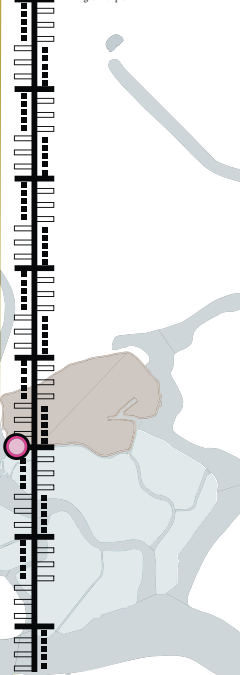

Z. The Prototypes: The Dice
 Resting spaces for the lost and dead people of the Adriatic Sea

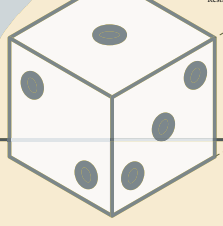

Lost in the system
 E.U. with its impenetrable borders, and Balkanese religious, is violating the UN Refugee Convention, causing the death and suffering of many people.

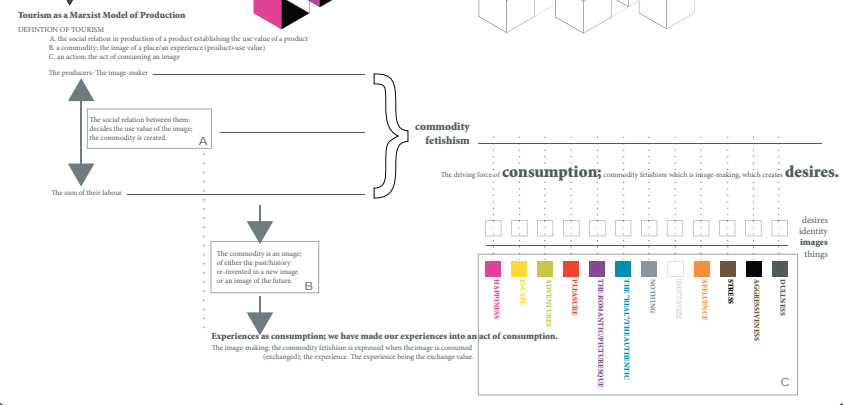
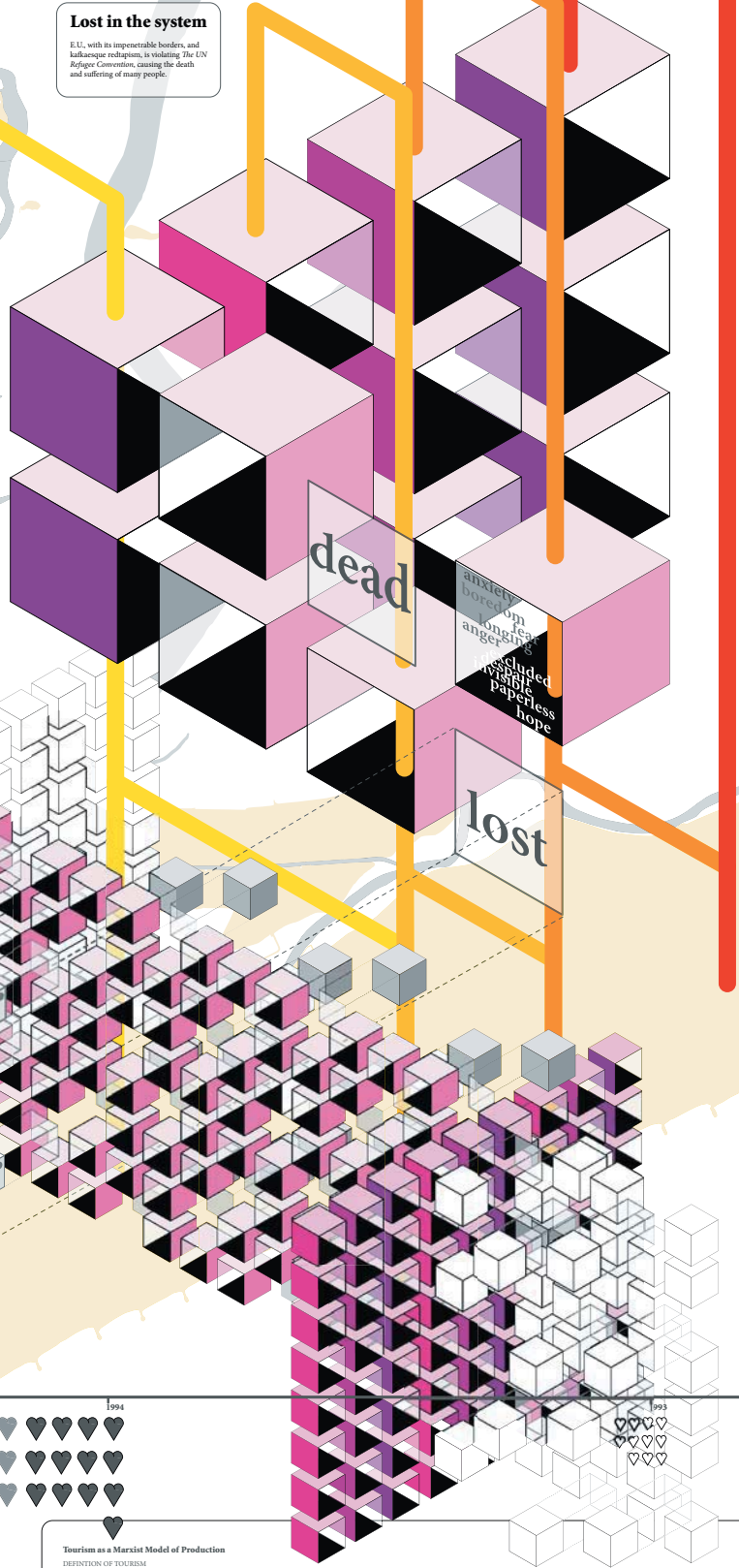

Greetings from Venice

The Park of the Involuntary Tourist

BIBLIOGRAPHY

Bibliography

Hannigan, J. (2006) *Fantasy City: Pleasure and profit in the postmodern metropolis*, New York: Routledge.

Marx, K. *The Capital, Volume One, Part I: Commodities and Money, Chapter One: Commodities Section 4 - The Fetishism of Commodities and the Secret thereof*

Pemble, J. (1995) *Venice: rediscovered*, Oxford University Press.

Web:

2G competition <http://www.2gcompetition.com/>

Dictionary.com

European council of refugees and exiles

<http://fortresseurope.blogspot.com/2006/01/i-numeri-delladriatico-anno-per-anno.html>

The swedish migration office
<http://www.migrationsverket.se/>

The Un <http://www.unhcr.org/cgi-bin/texis/vtx/protect?id=3c0762ea4>