

Systems Biology Graphical Notation: Activity Flow language Level 1

Release 1.0

Date: September 4, 2009

Editors:

Huaiyu Mi
Falk Schreiber
Nicolas Le Novère
Stuart Moodie
Anatoly Sorokin

SRI International, USA
IPK Gatersleben & MLU Halle, Germany
EMBL European Bioinformatics Institute, UK
CSBE, University of Edinburgh, UK
University of Edinburgh, UK [7pt]

To discuss any aspect of SBGN, please send your messages to the mailing list sbgn-discuss@sbgn.org. To get subscribed to the mailing list or to contact us directly, please write to sbgn-editors@lists.sourceforge.net. Bug reports and specific comments about the specification should be entered in the issue tracker http://sourceforge.net/tracker/?func=add&group_id=178553&atid=1175366.



Contents

1 Introduction	1	2.8.2 Glyph: <i>Or</i>	20
1.1 SBGN levels and versions	1	2.8.3 Glyph: <i>Not</i>	21
1.2 Developments, discussions, and notifications of updates	1	2.8.4 Glyph: <i>delay</i>	21
1.3 Note on typographical convention	2	3 Activity Flow language grammar	23
2 Activity Flow glyphs	3	3.1 Overview	23
2.1 Overview	3	3.2 Concepts	23
2.2 Controlled vocabularies used in SBGN Activity Flow Level 1	4	3.3 Syntax	23
2.2.1 Activity node material types	4	3.3.1 Activity Nodes connectivity definition	24
2.2.2 Activity node conceptual types	5	3.3.2 Containment definition	24
2.2.3 Physical characteristics of compartments	5	3.3.3 Syntactic rules	24
2.3 Activity nodes	5	3.4 Semantic rules	24
2.3.1 Glyph: <i>Biological activity</i>	6	3.4.1 Namespaces	24
2.3.2 Glyph: <i>Perturbation</i>	7	3.4.2 Compartments	25
2.3.3 Glyph: <i>Phenotype</i>	8	3.4.3 Modulation	25
2.4 Auxiliary units	8	3.4.4 Submaps	25
2.4.1 Glyph: <i>Unit of information</i>	8	4 Layout Guidelines for an Activity Flow Maps	26
2.5 Container nodes	10	4.1 Introduction	26
2.5.1 Glyph: <i>Compartment</i>	10	4.2 Layout guidelines	27
2.6 Glyph: <i>Submap</i>	13	4.2.1 Requirements	27
2.7 Modulation arcs	15	4.2.2 Recommendations	28
2.7.1 Glyph: <i>Positive influence</i>	15	4.2.3 Additional suggestions	29
2.7.2 Glyph: <i>Negative influence</i>	16	5 Acknowledgments	30
2.7.3 Glyph: <i>Unknown influence</i>	17	5.1 Level 1 Release 1.0	30
2.7.4 Glyph: <i>Necessary stimulation</i>	17	5.2 Comprehensive list of acknowledgements	30
2.7.5 Glyph: <i>Logic arc</i>	18	5.3 Financial Support	30
2.7.6 Glyph: <i>Equivalence arc</i>	19	A Examples	32
2.8 Logical operators	19	B Reference card	36
2.8.1 Glyph: <i>And</i>	19		

Chapter 1

Introduction

The goal of the **S**ystems **B**iology **G**raphical **N**otation (SBGN) is to standardize the graphical/visual representation of essential biochemical and cellular processes. SBGN defines comprehensive sets of symbols with precise semantics, together with detailed syntactic rules defining their use. It also describes the manner in which such graphical information should be interpreted. For a general description of SBGN, one can read:

Nicolas Le Novère, Michael Hucka, Huaiyu Mi, Stuart Moodie, Falk Schreiber, Anatoly Sorokin, Emek Demir, Katja Wegner, Mirit I Aladjem, Sarala M Wimalaratne, Frank T Bergman, Ralph Gauges, Peter Ghazal, Hideya Kawaji, Lu Li, Yukiko Matsuoka, Alice Villéger, Sarah E Boyd, Laurence Calzone, Melanie Courtot, Ugur Dogrusoz, Tom C Freeman, Akira Funahashi, Samik Ghosh, Akiya Jouraku, Sohyoung Kim, Fedor Kolpakov, Augustin Luna, Sven Sahle, Esther Schmidt, Steven Watterson, Guanming Wu, Igor Goryanin, Douglas B Kell, Chris Sander, Herbert Sauro, Jacky L Snoep, Kurt Kohn & Hiroaki Kitano. The Systems Biology Graphical Notation. *Nature Biotechnology* 27, 735 - 741 (2009). <http://dx.doi.org/10.1038/nbt.1558>

This document defines the *Activity Flow* visual language of SBGN. Activity Flows are one of three views of a biological process offered by SBGN. It is the product of many hours of discussion and development by many individuals and groups.

1.1 SBGN levels and versions

It was clear at the outset of SBGN development that it would be impossible to design a perfect and complete notation right from the beginning. Apart from the prescience this would require (which, sadly, none of the authors possess), it also would likely require a vast language that most newcomers would shun as being too complex. Thus, the SBGN community followed an idea used in the development of other standards, i.e. stratify language development into levels.

A *level* of one of the SBGN languages represents a set of features deemed to fit together cohesively, constituting a usable set of functionality that the user community agrees is sufficient for a reasonable set of tasks and goals. Within *levels*, *versions* represent small evolutions of a language, that may involve new glyphs, refined semantics, but no fundamental change of the way maps are to be generated and interpreted. Capabilities and features that cannot be agreed upon and are judged insufficiently critical to require inclusion in a given level, are postponed to a higher level or version. In this way, the development of SBGN languages is envisioned to proceed in stages, with each higher levels adding richness compared to the levels below it.

1.2 Developments, discussions, and notifications of updates

The SBGN website (<http://sbgn.org/>) is a portal for all things related to SBGN. It provides a web forum interface to the SBGN discussion list (sbgn-discuss@caltech.edu) and information

about how anyone may subscribe to it. The easiest and best way to get involved in SBGN discussions is to join the mailing list and participate.

Face-to-face meetings of the SBGN community are announced on the website as well as the mailing list. Although no set schedule currently exists for workshops and other meetings, we envision holding at least one public workshop per year. As with other similar efforts, the workshops are likely to be held as satellite workshops of larger conferences, enabling attendees to use their international travel time and money more efficiently.

Notifications of updates to the SBGN specification are also broadcast on the mailing list and announced on the SBGN website.

1.3 Note on typographical convention

The concept represented by a glyph is written using a normal font, while a *glyph* means the SBGN visual representation of the concept. For instance “a biological activity is encoded by the SBGN AF *biological activity*”.

Chapter 2

Activity Flow glyphs

This chapter provides a catalog of the graphical symbols available for representing entities in Activity Flows. In Chapter 3 beginning on page 23, we describe the rules for combining these glyphs into a legal SBGN Activity Flow map, and in Chapter 4 beginning on page 26, we describe requirements and guidelines for the way that Activity Flow maps are visually organized.

2.1 Overview

To set the stage for what follows in this chapter, we first give a brief overview of some of the concepts in the Activity Flow notation with the help of an example shown in Figure 2.1 on the following page.

The diagram illustrates the regulation of peroxisome proliferator-activated receptor delta (PPAR delta, a nuclear hormone receptor) on brown fat metabolism, a redraw from Fig 7E of Pan et. al [13]. The rectangle nodes represent *biological activities* - activities from biological materials. The type of material is indicated in the units of information decorating on the activity nodes (See Section 2.3.1). Each biological activity can influence, or be influenced by, other biological activities, and such relationships are represented in Activity Flow by lines with arrows and other decorations. It should be noted that the essence of Activity Flow is to show the flow of activities from one entity to another or within the same entity. For example, in the diagram, it shows that PPAR δ positively influences the Twist-1 gene expression. The underlying mechanisms of how the influence occurs may not be known and is not captured in the diagram. If the mechanism is known, the details should be described in annotation or captured in other SBGN languages, such as Process Description and/or Entity Relationship.

Table 2.1 summarizes the different SBGN abstractions described in this chapter.

Component	Abbrev.	Role	Examples
Activity node	AN	A functional unit that can affect, or be affected by, another functional unit.	Biological activity
Container node	CN	An encapsulation of one or more other SBGN constructs	Compartments
Modulating arc	MA	Links between different activities to indicate influences.	Positive influence, Negative influence
Auxiliary units	AU	A decorating glyph to the AN to provide additional information of the node, such as the property where the activity is originated	Unit of information
Logical operators	—	Combines one or several inputs into one output	Boolean <i>and</i> , <i>or</i> , <i>not</i>

Table 2.1: Summary of Activity Flow components and their roles.

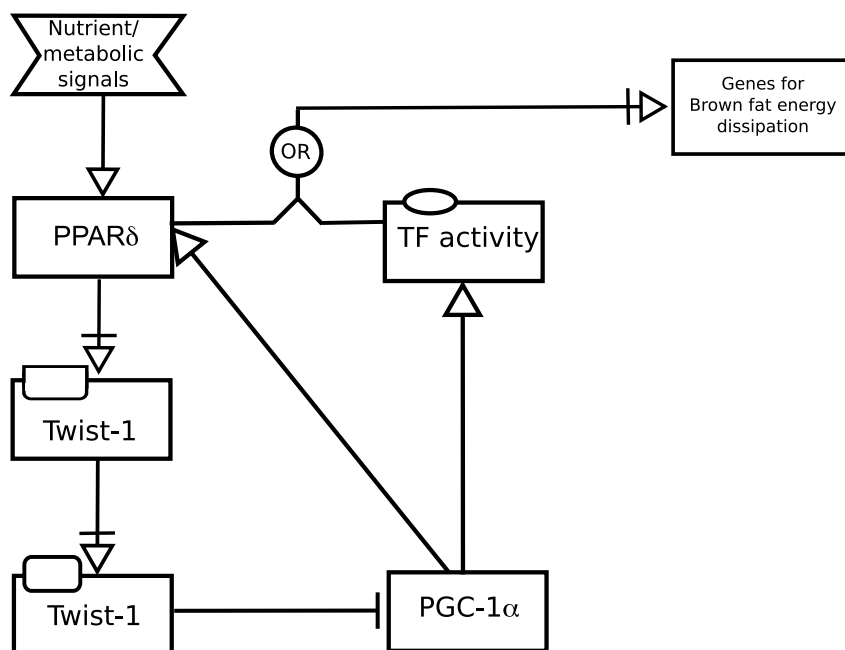

Figure 2.1: This example of Activity Flow depicts the effect of nutrients and metabolic signals on brown fat metabolism through PPAR δ . The signal, shown as a perturbation, positively influences the nuclear hormone receptor PPAR δ , which in turn stimulates the Twist 1 gene expression. Please note the different units of information on Twist 1 activity nodes that indicate the activity from different biological materials (gene and protein). The Twist-1 protein negatively influences the PGC-1 α activity, which positively influences PPAR δ and other unspecified transcription factor activity to stimulate the expression of genes for brown fat energy dissipation. Therefore, the Twist-1, induced by PPAR δ , serves as a negative feedback regulator of PGC-1 α in brown fat metabolism.

2.2 Controlled vocabularies used in SBGN Activity Flow Level 1

Some glyphs in SBGN Activity Flow can contain particular kinds of textual annotations conveying information relevant to the purpose of the glyph. These annotations are *units of information* (Section 2.4.1). An example is in the case of a compartment, which can have a unit of information conveying physical characteristics of the compartment.

The text that appears as the unit of information decorating an Activity Node (AN) or Container Node (CN) must in most cases be prefixed with a controlled vocabulary term indicating the type of information being expressed. Without the use of controlled vocabulary prefixes, it would be necessary to have different glyphs to indicate different classes of information; this would lead to an explosion in the number of symbols needed.

In the rest of this section, we describe the controlled vocabularies (CVs) used in SBGN Activity Flow Level 1. Some CV terms are predefined by SBGN, but unless otherwise noted, they are not the only terms permitted. Authors may use other CV values not listed here, but in such cases, they should explain the term's meanings in a Figure legend or other text accompanying the map.

2.2.1 Activity node material types

The material type of an AFN indicates its chemical structure. A list of common material types is shown in Table 2.2 on the following page, but others are possible. The values are to be taken from the Systems Biology Ontology (<http://www.ebi.ac.uk/sbo/>), specifically from the

branch having identifier **SBO:0000240** (*material entity* under *entity*). The labels are defined by SBGN Activity Flow Level 1.

Name	Label	SBO term
Non-macromolecular ion	mt:ion	SBO:0000327
Non-macromolecular radical	mt:rad	SBO:0000328
Ribonucleic acid	mt:rna	SBO:0000250
Deoxribonucleic acid	mt:dna	SBO:0000251
Protein	mt:prot	SBO:0000297
Polysaccharide	mt:psac	SBO:0000249

Table 2.2: A sample of values from the material types controlled vocabulary (Section 2.2.1).

The material types are in contrast to the *conceptual types* (see below). The distinction is that material types are about physical composition, while conceptual types are about roles. For example, a strand of RNA is a physical artifact, but its use as messenger RNA is a role.

2.2.2 Activity node conceptual types

An AFN's *conceptual type* indicates its function within the context of a given Activity Flow. A list of common conceptual types is shown in Table 2.3, but others are possible. The values are to be taken from the Systems Biology Ontology (<http://www.ebi.ac.uk/sbo/>), specifically from the branch having identifier **SBO:0000241** (*conceptual entity* under *entity*). The labels are defined by SBGN Activity Flow Level 1.

Name	Label	SBO term
Gene	ct:gene	SBO:0000243
Transcription start site	ct:tss	SBO:0000329
Gene coding region	ct:coding	SBO:0000335
Gene regulatory region	ct:grr	SBO:0000369
Messenger RNA	ct:mRNA	SBO:0000278

Table 2.3: A sample of values from the conceptual types vocabulary (Section 2.2.2).

2.2.3 Physical characteristics of compartments

SBGN Activity Flow Level 1 defines a special unit of information for describing certain common physical characteristics of compartments. Table 2.4 on the following page lists the particular values defined by SBGN Activity Flow Level 1. The values correspond to the Systems Biology Ontology branch with identifier **SBO:0000255** (*physical characteristic* under *quantitative parameter*).

2.3 Activity nodes

An Activity Node (AN) represents the activity of an entity or an entity pool, but not the entities themselves. For instance, multiple activity nodes can be used to represent different activities of a particular entity, while one activity node can be used to represent the activity of a complex multimer. In addition to activities of material entities, SBGN Activity Flow Level 1 represents activity from two conceptual entities: *perturbation*, *phenotype*. Auxiliary units, such as *units of*

Name	Label	SBO term
Temperature	pc:T	SBO:0000147
Voltage	pc:V	SBO:0000259
pH	pc:pH	SBO:0000304

Table 2.4: A sample of values from the physical characteristics vocabulary (Section 2.2.3).

information, can be used to indicate the material property of the activity source. Each activity is displayed only once in one compartment.

2.3.1 Glyph: *Biological activity*

SBGN Activity Flow Level 1 uses one glyph to represent activities from all biological entities, collectively they are called *biological activity*. The nature of the molecule that the activity comes from, eg., simple chemical or macromolecule, can be encoded in the *units of information* (Section 2.4.1).

It should be noted that the *biological activity* is not equivalent to a biological entity per se. A biological activity can come from one biological entity, a part of an entity, or a combination of them. It is up to the users to determine how to represent it in their diagram. For example, a protein kinase receptor such as an EGF receptor, has two activities, the binding activity that allows the extracellular part of the receptor to bind to the ligand, and the kinase activity that is capable of phosphorylating the downstream protein and initiating the intracellular signaling. The user can choose to use two nodes to represent each activity, or to use one node to represent the overall "EGF receptor activity".

SBO Term:

SBO:0000412 ! biological activity

Container:

A *biological activity* is represented by a rectangle, as shown in Figure 2.2 on the next page.

Label:

A *biological activity* is identified by a label placed in an unbordered box containing a string of characters. The characters can be distributed on several lines to improve readability, although this is not mandatory. The label box must be attached to the center of the container. The label may spill outside of the container.

Auxiliary items:

A *biological activity* can carry a *unit of information* (Section 2.4.1), which can provide information such as the nature of the entity from which the activity originated. Specific glyphs are used to represent different types of entities (Section 2.4.1). The center of the bounding box of a *unit of information* is located on the mid-line of the border of the *biological activity* node. The label in the *unit of information*, which is optional, indicates the name of the molecule where the activity comes from, as shown in Figure 2.3 on the following page.



Figure 2.2: *The Activity Flow glyph for biological activity.*

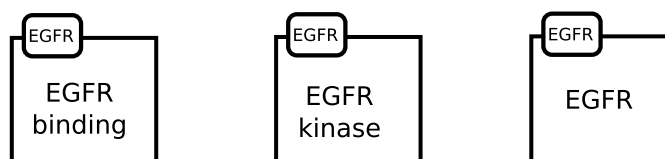

Figure 2.3: *An example of Activity Flow glyphs of EGFR activities. Since EGFR protein has both binding and kinase activities, each of those activity can be represented by different nodes, labeled as EGFR binding and EGFR kinase. One node can be used to represent the overall activity of EGFR. The label in the unit of information indicates the protein that the activities come from. In this example, all three activities come from the same EGFR protein*

2.3.2 Glyph: *Perturbation*

Biochemical networks can be affected by external influences. Those influences can be well-defined physical perturbations, such as a light pulse or a change in temperature; they can also be more complex and not well-defined phenomena, for instance, glucose deprivation, stress. For these situations, SBGN provides the perturbation glyph.

SBO Term:

SBO:0000357 ! perturbation

Container:

A *perturbation* is represented by a modified hexagon having two opposite concave faces, as illustrated in Figure 2.4.

Label:

A *perturbation* is identified by a label placed in an unbordered box containing a string of characters. The characters can be distributed on several lines to improve readability, although this is not mandatory. The label box must be attached to the center of the *perturbation* container. The label may spill outside of the container.



Figure 2.4: *The Activity Flow glyph for perturbation.*

2.3.3 Glyph: *Phenotype*

A biochemical network can generate phenotypes or affect biological processes. Such processes can take place at different levels and are independent of the biochemical network itself. To represent these processes in a diagram, SBGN defines the *phenotype* glyph.

SBO Term:

SBO:0000358 ! phenotype

Container:

A *phenotype* is represented by an elongated hexagon, as illustrated in Figure 2.5.

Label:

An *phenotype* is identified by a label placed in an unbordered box containing a string of characters. The characters can be distributed on several lines to improve readability, although this is not mandatory. The label box must be attached to the center of the *phenotype* container. The label may spill outside of the container.



Figure 2.5: *The Activity Flow glyph for phenotype.*

2.4 Auxiliary units

2.4.1 Glyph: *Unit of information*

When representing biological activities, it is often useful to illustrate the nature of the entity where the activity is originated, eg., whether the activity is from a macromolecule (protein or nucleic acid), or from a chemical compound. The SBGN Activity Flow Level 1 *unit of information* is used in this situation to add such information to a glyph. It represents the information in two ways. First, different symbols are used to represent the nature of the entity where the activity is from. These symbols are identical to the *entity pool node* symbols in SBGN Process Description language. Second, names of the entity (gene names, protein names) are usually provided as labels in the *unit of information* container.

SBO Term:

Not applicable.

Container:

A unit of information is represented by containers of different shapes, depending on the nature of the entity where the biological activity is from. There are a total of five types of unit of information, as shown in Figure 2.6 on page 10. Below is a summary of the five glyphs.

- A.** macromolecule – Macromolecules are biochemical substances that are built up from the covalent linking of pseudo-identical units. Examples of macromolecules include proteins, nucleic acids (RNA, DNA), and polysaccharides (glycogen, cellulose, starch, etc.). A unit of information of a macromolecule is represented by a rectangle with rounded corners, as illustrated in (A) of Figure 2.6 on page 10. This container is used to decorate a biological activity that is originated from a macromolecule, such as a protein, a nucleic acid, or a complex sugar.

- B.** nucleic acid feature – The Nucleic acid feature construct in SBGN is meant to represent a fragment of a macromolecule carrying genetic information. A unit of information of a nucleic acid feature is represented by a rectangle whose bottom half has rounded corners, as shown in (B) of Figure 2.6 on the next page.
- C.** simple chemical – A simple chemical is a chemical compound that is not formed by the covalent linking of pseudo-identical residues. Examples of simple chemicals are an atom, a monoatomic ion, a salt, a radical, a solid metal, a crystal, etc. A unit of information of a simple chemical is represented by a circular container, as shown in (C) of Figure 2.6 on the following page.
- D.** unspecified entity – An unspecified entity is used to represent the entity type that is unknown or simply not relevant to the purposes of the map. This arises, for example, when the existence of the entity has been inferred indirectly, or when the entity is merely a construct introduced for the needs of a map, without direct biological relevance. A unit of information of an unspecified entity is represented by an elliptic container, as shown in (D) of Figure 2.6 on the next page. It is used to decorate a biological activity that is originated from an unspecified entity.
- E.** complex – A complex represents a biochemical entity composed of other biochemical entities, whether macromolecules, simple chemicals, or other complexes. The resulting entity may have its own identity, properties and function in an SBGN map. A unit of information of a complex is represented by an octagon as shown in (E) of Figure 2.6 on the following page. It is used to decorate a biological activity that is originated from a complex.

The long side of the glyphs above (except for simple chemical) should be oriented parallel to the border of the *AN* being annotated by the *unit of information*. The center of the bounding box of a *state of information* should be located on the mid-line of the border of the *AN*.

Label:

A *unit of information* is identified by a label placed in an unbordered box containing a string of characters. The characters can be distributed on several lines to improve readability, although this is not mandatory. The label box must be attached to the center of the container. The label may spill outside of the container. The label defines the information carried by the *unit of information*.

Auxiliary items:

A *unit of information* does not carry any auxiliary items.

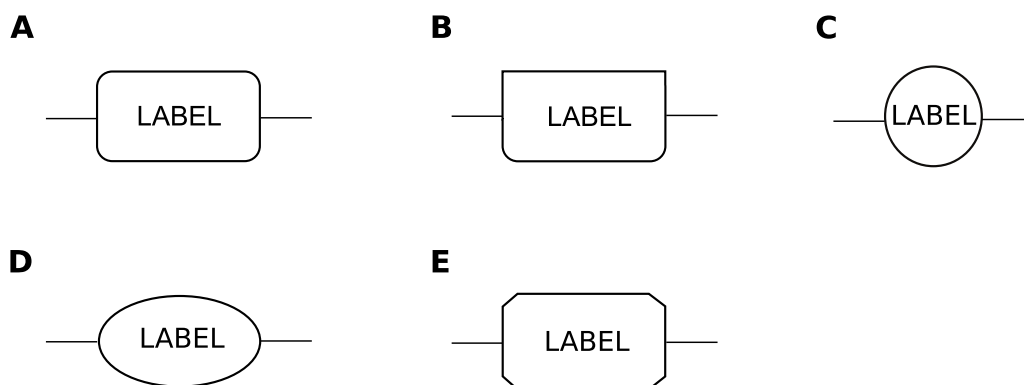

Figure 2.6: *The Activity Flow glyph for unit of information.*

Figure 2.7 shows examples units of information used on Activity Nodes to illustrate the properties of the entities that the activities are originated from. A. Macromolecule. B. Nucleic acid feature. C. Simple chemical. D. Unspecified. D. Complex.

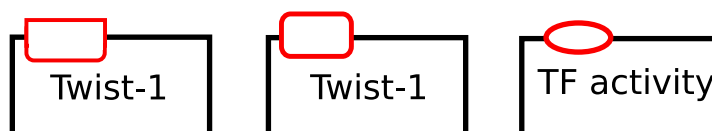

Figure 2.7: *Examples of unit of information used on biological activity node to indicate that the activity is from a gene, a macromolecule, or unspecified.*

2.5 Container nodes

Containers are SBGN constructions that contain one or several other SBGN constructs. In SBGN Activity Flow Level 1 *compartment* is the only container node.

2.5.1 Glyph: *Compartment*

In order to describe biochemical and cellular events, it is useful to define the notion of pools. A pool is an ensemble of participants that can be considered to be identical for the events in which they are involved. A compartment is a logical or physical structure that contains pools. A pool can only belong to one compartment. Therefore, the “same” biochemical activities located in two different compartments are in fact two different activities, corresponding to different pools.

SBO Term:

SBO:0000289 ! functional compartment

Container:

A compartment is represented by a surface enclosed in a continuous border or located between continuous borders. These borders should be noticeably thicker than the borders of the ANs. A compartment can take **any** geometry. A compartment must always be entirely enclosed.

Label:

The identification of the compartment is carried by an unbordered box containing a string

of characters. The characters can be distributed on several lines to improve readability, although this is not mandatory. The label box can be attached anywhere in the container box. Note that the label can spill-over from the container box.

Auxiliary items:

A *compartment* can carry a certain number of *units of information*, that will add information for instance about the physical environment, such as pH, temperature or voltage, see Section 2.4.1. The center of the bounding box of a *unit of information* is located on the mid-line of the border of the compartment.

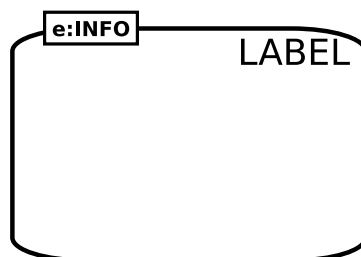

Figure 2.8: *The Activity Flow glyph for compartment.*

It is important to note that a compartment never contains another compartment, but may surround it. A key aspect of correctly drawing two “adjacent” compartments is that they are not separated by one line, but by **two** lines. Figure 2.9 provides an example of this in which a cell is shown made up of a nucleus surrounded by the cytoplasm.

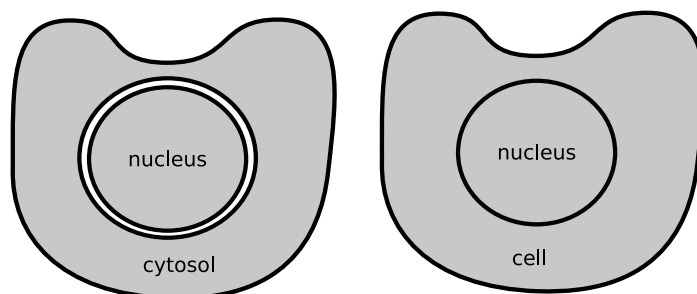

Figure 2.9: *Compartments can surround other compartments; in that case, both of the compartment’s borders must still be shown, with the result that the separation is drawn as two lines. This figure shows two equivalent views representing the “cytoplasm” and the “nucleus”.*

The example diagram in Figure 2.10 on the next page represents three adjacent compartments. Two of the compartments carry units of information. Notice that these units of information do not overlap multiple membrane boundaries.

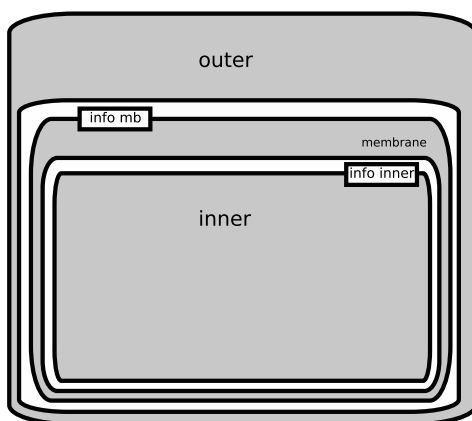

Figure 2.10: *Illustration of units of information and surrounding compartments.*

To allow more aesthetically pleasing and understandable diagrams, compartments are allowed to overlap each other visually, but it must be kept in mind that this does not mean the top compartment contains part of the bottom compartment. Figure 2.11 shows two semantically equivalent placement of compartments:

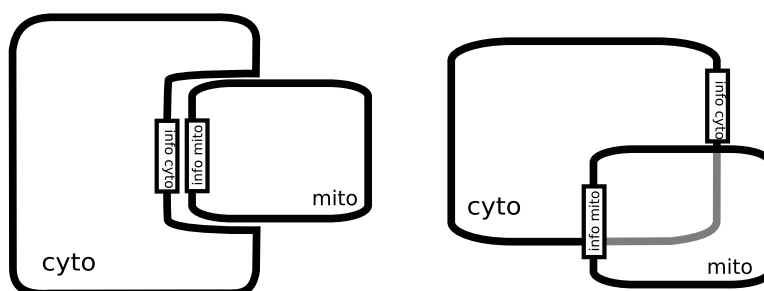

Figure 2.11: *Overlapped compartments are permitted, but the overlap does not imply containment.*

Overlapped (hidden) part of the compartment should not contain any object which could be covered by an overlapping compartment. Figure 2.12 on the next page illustrates the problem using an incorrect diagram.

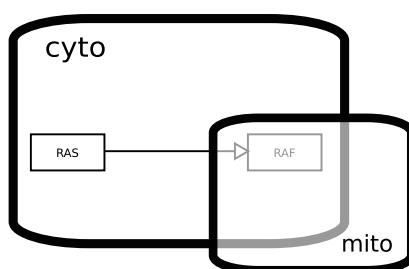

Figure 2.12: Example of an *incorrect* diagram. Overlapped compartments must not obscure other objects.

2.6 Glyph: Submap

A *submap* is used to encapsulate processes (including all types of nodes and edges) within one glyph. The submap hides its content to the users, and displays only input terminals (or ports), linked to *ANs*. In the case of an SBGN diagram that is made available through a software tool, the content of a submap may be available to the tool. A user could then ask the tool to expand the submap, for instance by clicking on the icon for the submap. The tool might then expand and show the submap within the same diagram (on the same canvas), or it might open it in a different canvas.

SBO Term:

SBO:0000395 ! encapsulating process

Container:

The *submap* is represented as a rectangle box to remind the viewer that it is fundamentally a biological activity node.

Label:

The identification of the *submap* is carried by an unbordered box containing a string of characters. The characters may be distributed on several lines to improve readability, although this is not mandatory. The label box has to be attached to the center of the container box.

Auxiliary items:

A *submap* carries labeled terminals. When the submap is represented folded, those terminals are linked to external *ANs*. In the unfolded view, exposing the internal structure of the submap, a set of *tags* point to the corresponding internal *ANs*.

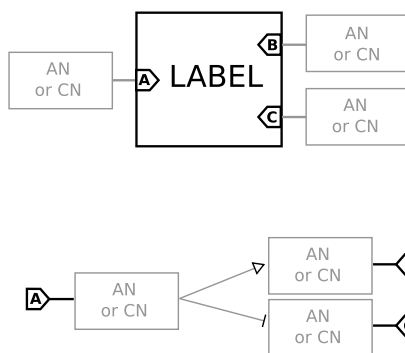

Figure 2.13: *The Activity Flow glyph for submap. (Upper part) folded submap. (Lower part) content of the submap.*

Figure 2.14 represents a *submap* of inhibitory G-protein coupled receptor signaling. The *submap* carries five terminals, three linked to biological ANs, and two linked to *compartments*. Note that the terminals do not define a “direction”, such as input or output. The flux of the reactions is determined by the context.

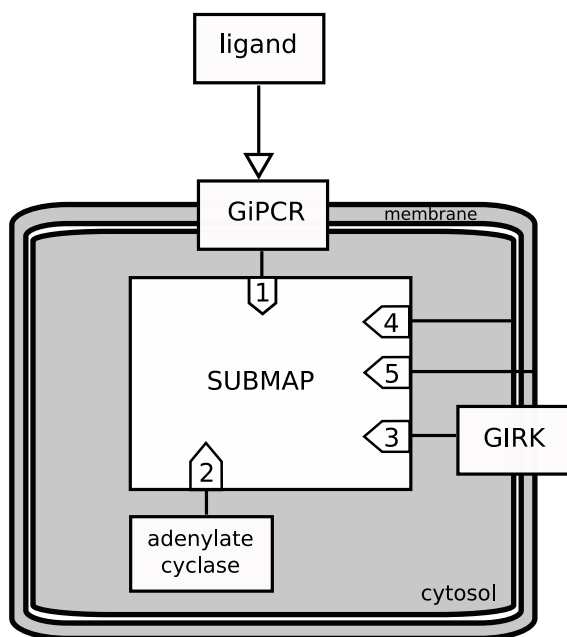

Figure 2.14: *Example of a submap with contents elided.*

The diagram in Figure 2.15 on the next page represents an unfolded version of a submap. Here, anything outside the submap has disappeared (e.g., ligand in Figure 2.14), and the internal *tags* are not linked to the corresponding external *terminals*.

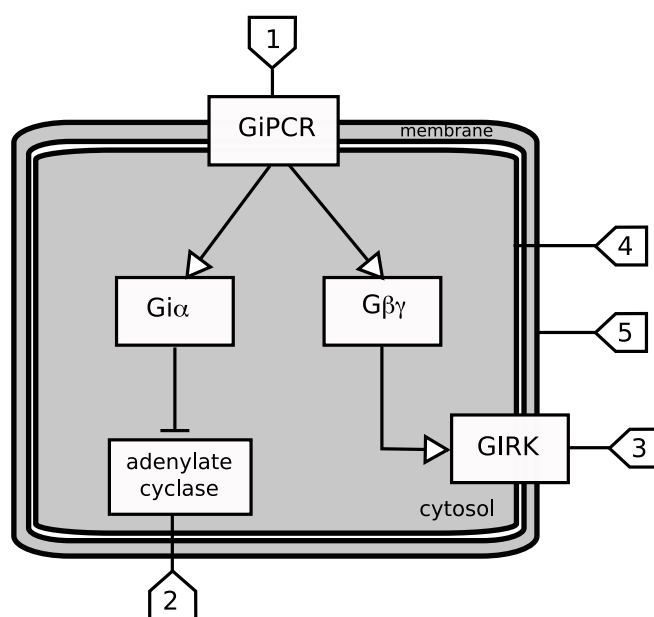

Figure 2.15: Example of an unfolded submap. The unfolded submap corresponds to the folded submap of Figure 2.14 on the preceding page.

2.7 Modulation arcs

Modulation arcs are lines that link ANs together. The symbols attached to their end extremities indicate their semantics. The modulation arcs can be used to represent direct influence from one activity to another, such as nicotine to nicotinic acetylcholine receptor activity, or indirect influence.

2.7.1 Glyph: *Positive influence*

In SBGN Activity Flow Level 1, a *positive influence* is defined as an action that produces positive or activating effect from one activity to another.

SBO Term:

SBO:0000170 ! stimulation

Origin:

Any *biological activity* (Section 2.3.1), *perturbation* (Section 2.3.2) or any *logical operator* (Section 2.8).

Target:

Any *biological activity* (Section 2.3.1) or *phenotype* (Section 2.3.3).

End point:

The target extremity of a *positive influence* carries an open arrow pointing to the target activity node (Figure 2.16 on the next page).



Figure 2.16: *The Activity Flow glyph for positive influence.*

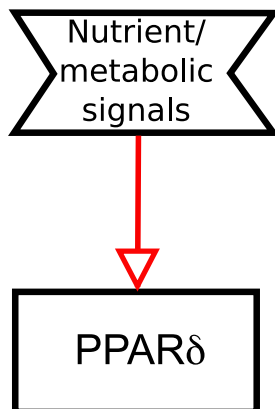

Figure 2.17: *An example of positive influence from a perturbation to the nuclear hormone receptor PPAR δ .*

2.7.2 Glyph: *Negative influence*

A *negative influence* is defined as an action that produces a negative or inhibiting effect from one activity to another.

SBO Term:

SBO:0000169 ! inhibition

Origin:

Any *biological activity* (Section 2.3.1), *perturbation* (Section 2.3.2) or any *logical operator* (Section 2.8).

Target:

Any *biological activity* (Section 2.3.1) or *phenotype* (Section 2.3.3).

End point:

The target extremity of a *negative influence* carries a bar perpendicular to the arc (Figure 2.18).

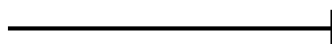

Figure 2.18: *The Activity Flow glyph for negative influence.*



Figure 2.19: An example of negative influence from "Twist-1" activity to "PGC-1 α " activity.

2.7.3 Glyph: *Unknown influence*

An *unknown influence* is used when the effect exerted from one activity to another is not well understood, or sometimes understood but complex.

SBO Term:

SBO:0000168 ! control

Origin:

Any *biological activity* (Section 2.3.1), *perturbation* (Section 2.3.2) or any *logical operator* (Section 2.8).

Target:

Any *biological activity* (Section 2.3.1) or *phenotype* (Section 2.3.3).

End point:

The target extremity of a *unknown influence* carries an open diamond (Figure 2.20).

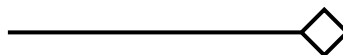

Figure 2.20: The Activity Flow glyph for unknown influence.

2.7.4 Glyph: *Necessary stimulation*

A *necessary stimulation* is an influence that has to be present for the target activity to take place (to become true). An activity modulated by a necessary stimulation can only exist when this stimulation is true, whatever are the other influences this activity is subjected to.

SBO Term:

SBO:0000171 ! necessary stimulation

Origin:

Any *biological activity* (Section 2.3.1), *perturbation* (Section 2.3.2) or any *logical operator* (Section 2.8).

Target:

Any *biological activity* (Section 2.3.1) or *phenotype* (Section 2.3.3).

End point:

The target extremity of a *necessary stimulation* carries a perpendicular bar followed by an open arrow pointing to the target activity node (Figure 2.21). The bar has to be bigger than the based of the arrowhead.

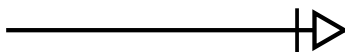

Figure 2.21: *The Activity Flow glyph for necessary stimulation.*

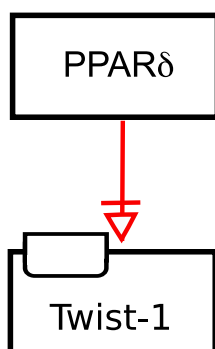

Figure 2.22: *An example of necessary stimulation where nuclear hormone receptor PPAR δ transcription factor activity stimulates the gene expression of Twist-1.*

2.7.5 Glyph: *Logic arc*

Logic arc is used to represent the fact that an activity influences the outcome of a logic operator.

SBO Term:

SBO:0000398 ! logical relationship.

Origin:

Any *Activity node* (Section 2.3) or any *logical operator* (Section 2.8).

Target:

Any *logical operator* (Section 2.8).

End point:

No particular symbol is used to represent a logic arc.

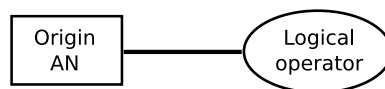

Figure 2.23: *The Activity Flow glyph for logic arc.*

2.7.6 Glyph: *Equivalence arc*

Equivalence Arc is the arc used to represent the fact that all activities or compartments marked by a *tag* are equivalent. Since each AN can only appear once in a compartment, this arc is not going to be used in any main Activity Flow map. It is useful, however, to show that an AN in a submap and another AN in the main map are equivalent.

SBO Term:

Not applicable.

Origin:

Any *Activity node* (Section 2.3) or any *compartment*.

Target:

Tag.

End point:

No particular symbol is used to represent the end of an *equivalence arc*.

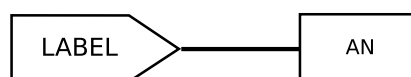

Figure 2.24: *The Activity Flow glyph for Equivalence arc.*

2.8 Logical operators

2.8.1 Glyph: *And*

The glyph *and* is used to denote that all the ANs linked as input are necessary to influence the target activity.

SBO Term:

SBO:0000173 ! and.

Origin:

More than one AN (Section 2.3) and *logical arcs* (section 2.7.5).

Target:

Modulation arc (Section 2.7) other than *equivalence arc*.

Node:

And is represented by a circle carrying the word “AND”, with two connectors located at the opposite side for inputs and output.

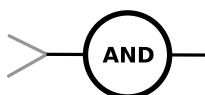

Figure 2.25: *The Activity Flow glyph for and. Only two inputs are represented, but more would be allowed.*

2.8.2 Glyph: Or

The glyph *or* is used to denote that any of the ANs linked as input is sufficient to influence the target activity.

SBO Term:

SBO:0000174 ! or.

Origin:

More than one AN (Section 2.3) and *logical arcs* (section 2.7.5).

Target:

Modulation arc (Section 2.7) other than *equivalence arc*.

Node:

Or is represented by a circle carrying the word “OR”, with two connectors located at the opposite side for inputs and output.

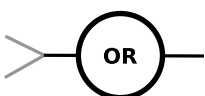

Figure 2.26: *The Activity Flow glyph for or. Only two inputs are represented, but more would be allowed.*

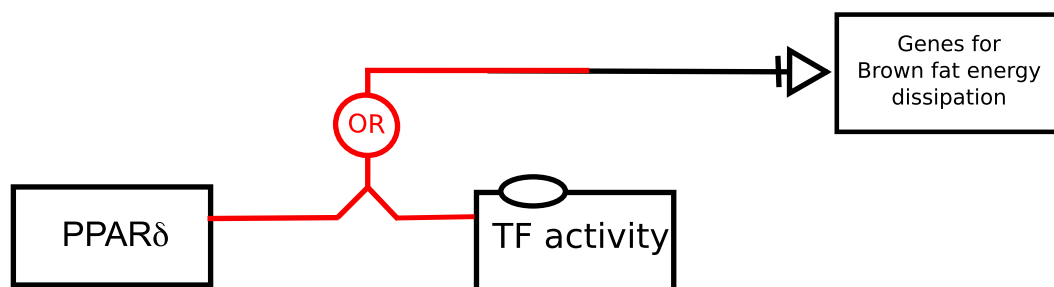

Figure 2.27: An example of the or logic operator, where the "Genes for brown fat energy dissipation" is stimulated by either the PPAR delta activity or an unspecified transcription factor activity.

2.8.3 Glyph: *Not*

The glyph *not* is used to denote that the *AN* linked as input cannot influence the target activity.

SBO Term:

SBO:0000238 ! not.

Origin:

One *AN* (section 2.3) or and a *logical arc* (section 2.7.5).

Target:

A *modulation arc* (section 2.3) other than *equivalence arc*.

Node:

Not is represented by a circle carrying the word "NOT", with two connectors located at the opposite side for inputs and output.

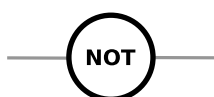

Figure 2.28: The Activity Flow glyph for not.

2.8.4 Glyph: *delay*

The glyph *delay* is used to denote that the *activity node* linked as input does not produce the influence immediately.

SBO Term:

SBO:0000225 ! delay.

Origin:

One *AN* (section 2.3) or and a *logical arc* (section 2.7.5).

Target:

A *modulation arc* (section 2.3) other than *equivalence arc*.

Container:

Delay is represented by a circle, with two connectors located at the opposite side for inputs and output.

Label:

Delay is identified by the greek letter “ τ ” (“TAU”) placed in an unbordered box attached to the center of the container.

Auxiliary items:

Delay does not carry any auxiliary items.

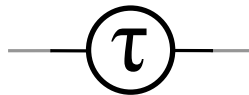

Figure 2.29: *The Activity Flow glyph for delay.*

Chapter 3

Activity Flow language grammar

3.1 Overview

In this chapter, we describe how the glyphs of SBGN Activity Flow can be combined to make a valid SBGN Activity Flow map. To do this, we must at the very least define what glyphs can be connected to each other. This is called syntax. Next, we must define rules over and above connection rules, such as whether duplicate symbols are permitted. In addition, we must define what the notation “means” – how does it represent a biological pathway? This is semantics, and it is essential if a reader is to understand a SBGN map without external help, and a writer is to create one that reflects his understanding of a biological system.

In this section we start off by describing the concepts of the Activity Flow notation. Next a detailed description of the syntax is provided followed by a description of the syntactic rules of the notation.

3.2 Concepts

The SBGN Activity Flow is more than a collection of symbols. It is a visual language that uses specific abstractions to describe the biological activities that make up model, a signalling pathway or a metabolic network. This abstraction is the semantics of SBGN, and to describe it requires more than a definition of the symbols and syntax of the language.

The Activity Flow in SBGN describes biological activities involving biological entities. A *biological activity* can influence, or be influenced by, other *biological activities*, and such relationships are represented in Activity Flow by lines with arrows and other decorations. So the essence of Activity Flow is to show the flow of activities from one entity to another or within the same entity. The underlying mechanisms of how the influence occurs may not be known and is not captured in the diagram. If the mechanism is known, the details should be described in annotation or captured in other SBGN languages, such as Process Description and/or Entity Relationship.

3.3 Syntax

The syntax of the SBGN Activity Flow language is defined in the form of an incidence matrix. An incidence matrix has arcs as rows and nodes as columns. Each element of the matrix represents the role of an arc in connection to a node. Input (I) means that the arc can begin at that node. Output (O) indicates that the arc can end at that node. Numbers in parenthesis represent the maximum number of arcs of a particular type to have this specific connection role with the node. Empty cells means the arc is not able to connect to the node.

3.3.1 Activity Nodes connectivity definition

<i>Arc\Node</i>	<i>biological activity</i>	<i>perturbation</i>	<i>phenotype</i>	<i>tag</i>	<i>submap</i>	<i>and</i>	<i>or</i>	<i>not</i>	<i>delay</i>
<i>positive influence</i>	I & O	I	O			I	I	I	I
<i>negative influence</i>	I & O	I	O			I	I	I	I
<i>unknown influence</i>	I & O	I	O			I	I	I	I
<i>necessary stimulation</i>	I & O	I	O			I	I	I	I
<i>logic arc</i>	I					O	O	O(1)	O
<i>equivalence arc</i>	I			O	O				

3.3.2 Containment definition

There are two node types allowing containment of AF in SBGN: *container (compartment)* and *submap*. The next table describes relationship between AF elements of SBGN and these two nodes. Plus sign means that the element is able to be contained within a node. An empty cell means containment is not allowed.

<i>elements\Containers</i>	<i>compartment</i>	<i>submap</i>
<i>biological activity</i>	+	+
<i>perturbation</i>	+	+
<i>phenotype</i>	+	+
<i>tag</i>	+	+
<i>compartment</i>	-	+
<i>submap</i>	+	+
<i>positive influence</i>	+	+
<i>negative influence</i>	+	+
<i>unknown influence</i>	+	+
<i>logic arc</i>	+	+
<i>equivalence arc</i>	+	+
<i>and</i>	+	+
<i>or</i>	+	+
<i>not</i>	+	+

3.3.3 Syntactic rules

There are additional syntactic rules that must be applied in addition to those defined above.

3.3.3.1 AFs

1. Each *biological activity* has at most one *unit of information*.
2. *Perturbation* is never target of a modulation arc.
3. *Phenotype* is never origin of a modulation arc.

3.4 Semantic rules

3.4.1 Namespaces

The notation has a concept of a namespace within which entities with the same identifying attributes are regarded as identical. The SBGN namespaces are shown in table 3.1.

Table 3.1: *Namespace scope definitions.*

Namespace Scope	Activity influenced	Notes
MapDiagram	CompartmentNode, SubMapDiagram, EquivalenceNode	
CompartmentShape	ActivityNode	If no <i>compartment</i> is drawn then all ActivityNodes are assumed to belong to an invisible “default” compartment.
ActivityType	UnitOfInformation	

3.4.2 Compartments

In all cases an AN cannot *belong* to more than one compartment. However, an AN can be *drawn* over more than one compartment. In such cases the decision on which is the owning compartment is deferred to the drawing tool or the author.

The layout of compartments in an SBGN diagram does not imply anything about the topology of compartments in the cell. Compartments should be bounded and may overlap. However, adjacency and the nesting of compartments does not imply that these compartments are next to each other physically or that one compartment contains the other.

3.4.3 Modulation

It is implied, but not defined explicitly that an activity has a rate at which the input AN effects the output AN.

1. Positive influence is a modulation that’s effect is to increase the basal activity.
2. Negative influence is a modulation that’s effect is to decrease the basal activity.
3. Unknown influence is a modulation where the effect and basal activity is unknown.
4. At most one necessary stimulation can be assigned to an activity. Two necessary stimulations would imply an implicit Boolean AND or OR operator. For clarity only one necessary stimulation can be assigned to an activity node and such combinations must be explicitly expressed as the Boolean operators.

3.4.4 Submaps

Submaps are a visual device that allow a map to be split into several views. They remain, however, part of the main map and share its namespace. As a test of validity it should be possible to reintroduced a submap into the main map by eliminating the SubMapNode and merging the equivalent nodes in both maps.

3.4.4.1 Rules for mapping to submaps

An AN in the main map can be mapped to one in the submap using a TagNode in the submap and SubMapTerminals (see Section 2.6) in the main map. For a mapping between map and submap to exist the following must be true:

1. The identifiers in the TagNode and SubMapTerminals must be identical.
2. The AFNs must be identical.

3.4.4.2 Requirement to define a mapping

If a map and submap both contain the same AN, then a mapping between them must be defined as above.

Chapter 4

Layout Guidelines for an Activity Flow Maps

4.1 Introduction

The previous chapters describe the appearance and meaning of SBGN Activity Flow Level 1 components. Objects are *activity nodes*, *container nodes*, *logical operators*, *submaps* as well as *connecting arcs*. The components of an Activity Flow map have to be placed in a meaningful way – a random distribution with spaghetti-like connections will most likely hide the information encoded in the underlying model, whereas an elegant placement of the objects, giving a congenial appearance of the maps, may reveal new insights. The arrangement of components in a map is called a *layout*.

SBGN Activity Flows should be easily recognisable not only by the glyphs used, but also by the general style of the layout. However, the arrangement of the components is a complex art in itself, and there is no simple rule which can be applied to all cases. Therefore this section provides guidelines for the layout of process diagrams, divided into two categories:

1. requirements, i.e., rules which **must** be fulfilled by a layout, and
2. recommendations, i.e., rules which **should** be followed if possible.

In addition, we provide a list of additional suggestions which may help in producing aesthetically more pleasant layouts, possibly easier to understand.

Those layout guidelines are independent of the method used to produce the map, and apply to both manually drawn maps as well as maps produced by an automatic layout algorithm. The guidelines do not deal with interactive aspects (e.g., the effect of zooming). Further information about automatic network layout (graph drawing) can be found, for example, in the books of Di Battista and co-authors [14] and Kaufmann and Wagner [15].

Please note that the color of objects do not carry any meaning in SBGN. Although one can use colors to emphasize part of a diagram or encode additional information, the meaning of the diagram should not depend on the colors. Furthermore, objects can have different sizes and size is also meaningless in SBGN. For example, one biological activity node may be larger than another node. Also the meaning of a graph should be conserved upon scaling as far as possible.

4.2 Layout guidelines

4.2.1 Requirements

Requirements are rules which **must** be fulfilled by a layout to produce a valid SBGN Activity Flow Level 1 map.

4.2.1.1 Node-node overlaps

Nodes are only allowed to overlap in two cases:

1. the overlapping nodes define a glyph (e.g., a stacking of *biological activity* and *unit of information*).
2. nodes overlapping compartments (e.g., a biological activity placed on the compartment border).

Otherwise, nodes are not allowed to overlap (Figure 4.1). This includes the touching of nodes, which is also not allowed. Also submaps are not allowed to overlap.

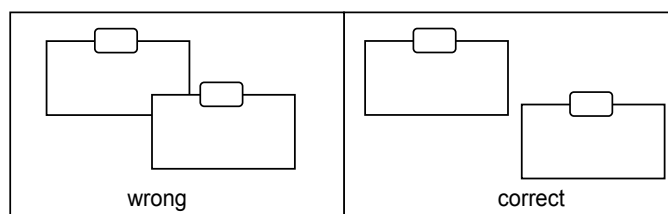

Figure 4.1: Nodes must not overlap.

4.2.1.2 Node-edge crossing

In case of node-edge crossing the edge must be drawn on the top of the node (Figure 4.2). See also recommendation 4.2.2.1 (crossing between edges and nodes should be avoided).

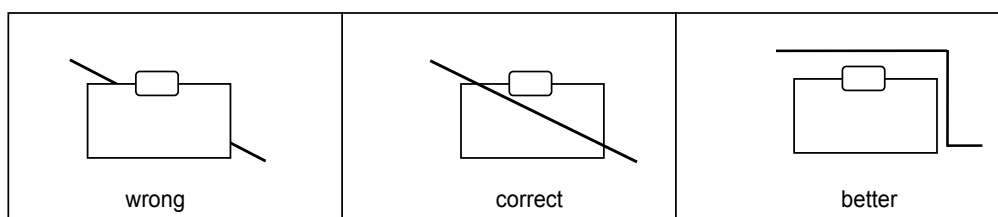

Figure 4.2: If an edge crosses a node, the edge must be drawn on top of the node.

4.2.1.3 Node border-edge overlaps

Edges are not allowed to overlap the border lines of nodes (Figure 4.3 on the next page).

4.2.1.4 Edge-edge overlaps

Edges are not allowed to overlap (Figure 4.4 on the following page). This includes touching of edges. Furthermore, an edge is neither allowed to cross itself nor to cross a boundary of node more than twice or other edges more than once.

4.2.1.5 Node orientation

Nodes have to be drawn horizontally or vertically, any other rotation of elements is not allowed (Figure 4.5 on the next page).

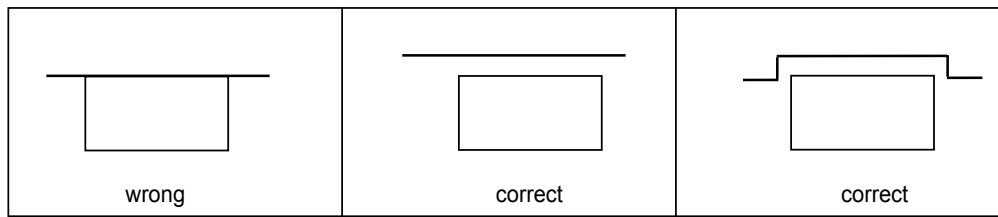

Figure 4.3: *Edges must not overlap node borders.*

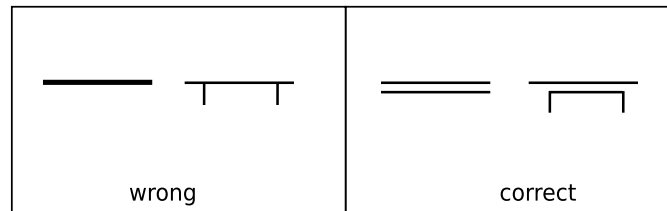

Figure 4.4: *Edges must not overlap.*

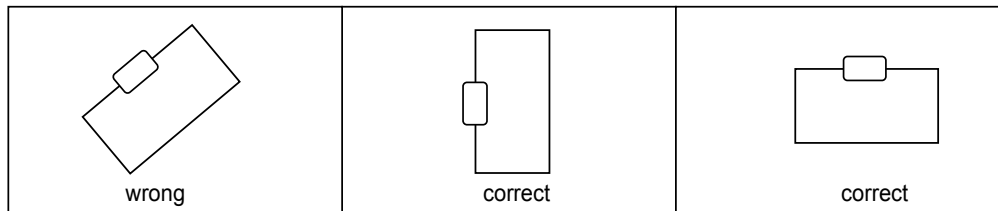

Figure 4.5: *The node orientation must be horizontally or vertically.*

4.2.1.6 Node labels

At least a part of the label (unbordered box containing a string of characters) has to be placed inside the node it belongs to. Node labels are not allowed to overlap nodes or other labels (this includes touching of other nodes or labels).

4.2.1.7 Edge labels

Edge labels are not allowed to overlap nodes. This includes touching of nodes.

4.2.1.8 Compartments

If an activity has all participants in the same compartment the activity node and all edges/arcs have to be in this compartment. If an activity has participants in at least two different compartments, the activity node has to be either in a compartment where the activity has at least one participant or in the empty space.

4.2.2 Recommendations

Recommendations are rules which should be followed if possible to produce layouts may be easier to understand.

4.2.2.1 Node-edge crossing

Crossings between edges and nodes should be avoided. Some crossings may be unavoidable, e.g., the crossing between an edge and a compartment border. See also requirement 4.2.1.2 (in case of node-edge crossings the edge must be drawn on the top of the node).

4.2.2.2 Labels

Labels should be horizontal. Node labels should be placed completely inside the node if possible. Edge labels should be placed close to the edge and avoid overlapping the edge as well as other edge labels.

4.2.2.3 Avoid edge crossings

The amount of crossings between edges should be minimized.

4.2.3 Additional suggestions

Here is a list of additional layout suggestions which may help in producing aesthetically more pleasing layouts which may be easier to understand.

- Angle of edge crossings: If edge crossings are not avoidable edges should cross with an angle close to 90 degrees.
- Drawing area and width/height ratio: The drawing should be compact and the ratio between the width and the height of the drawing should be close to 1.
- Edge length: Long edges should be avoided.
- Number of edge bends: Edges should be drawn with as few bends as possible.
- Similar and symmetric parts: Similar parts of a map should be drawn in a similar way, and symmetric parts should be drawn symmetrically.
- Proximity information: Related elements (e.g., nodes connected by edges within a compartment) should be drawn close together.
- Directional information: Subsequent activities (e.g., a sequence of activities) should be drawn in one direction (e.g., from top to bottom or from left to right).
- Compartments: Different compartments should have different background shade or color.

Chapter 5

Acknowledgments

Here we acknowledge those people and organisations that assisted in the development of this and previous releases of the SBGN Activity Flow language specification. First we specifically acknowledge those who contributed directly to each revision of the specification document, followed by a comprehensive acknowledgement of contributors that attended workshops and forum meetings or in some other way provided input to the standard. Finally, we acknowledge the bodies that provided financial support for the development of the standard.

We aim this list to be rather complete. We are very sorry if we forgot someone, and will be grateful if you notified us of any omission.

5.1 Level 1 Release 1.0

The specification was written by Huaiyu Mi, Falk Schreiber, Nicolas Le Novère, Stuart Moodie, Anatoly Sorokin, Michael Hucka, Emek Demir, Yukiko Matsuoka, Katja Wegner and Hiroaki Kitano. In addition, the specification benefited much from the help of Frank Bergmann, Sarala Dissanayake and Paul Thomas.

5.2 Comprehensive list of acknowledgements

Here is a more comprehensive list of people who have been actively involved in SBGN development, either by their help designing the languages, their comments on the specification, help with development infrastructure or any other useful input. We aim this list to be rather complete. We are very sorry if we forgot someone, and will be grateful if you notify us of any omission.

Mirit Aladjemm, Frank Bergmann, Sarah Boyd, Laurence Calzone, Melanie Courtot, Emek Demir, Ugur Dogrusoz, Tom Freeman, Akira Funahashi, Ralph Gauges, Peter Ghazal, Samik Ghosh, Igor Goryanin, Michael Hucka, Akiya Jouraku, Hideya Kawaji, Douglas Kell, Sohyoung Kim, Hiroaki Kitano, Kurt Kohn, Fedor Kolpakov, Nicolas Le Novère, Lu Li, Augustin Luna, Yukiko Matsuoka, Huaiyu Mi, Stuart Moodie, Sven Sahle, Chris Sander, Herbert Sauro, Esther Schmidt, Falk Schreiber, Jacky Snoep, Anatoly Sorokin, Jessica Stephens, Linda Taddeo, Paul, Thomas, Steven Watterson, Alice Villéger, Katja Wegner, Sarala Wimalaratne, Guanming Wu.

The authors are also grateful to all the attendees of the SBGN meetings, as well as to the subscribers of the sbgn-discuss@sbgn.org mailing list.

5.3 Financial Support

The development of SBGN was mainly supported by a grant from the Japanese *New Energy and Industrial Technology Development Organization* (NEDO, <http://www.nedo.go.jp/>). The *Okinawa Institute of Science and Technology* (OIST, <http://www.oist.jp/>), the *AIST Computational Biology Research Center* (AIST CBRC, <http://www.cbrc.jp/index.eng.html>) the British *Biotechnology and Biological Sciences Research Council* (BBSRC, [30](http://www.</p></div><div data-bbox=)

bbsrc.ac.uk/) through a Japan Partnering Award, the European Media Laboratory (EML Research gGmbH, <http://www.eml-r.org/>), and the Beckman Institute at the California Institute of Technology (<http://bnmc.caltech.edu>) provided additional support for SBGN workshops. Some help was provided by the *Japan Science and Technology Agency* (JST, <http://www.jst.go.jp/>) and the *Genome Network Project* of the Japanese Ministry of Education, Sports, Culture, Science, and Technology (MEXT, <http://www.mext.go.jp/>) for the development of the gene regulation network aspect of SBGN, and from the *Engineering and Physical Sciences Research Council* (EPSRC, <http://www.epsrc.ac.uk>) during the redaction of the specification.

Appendix A

Examples

The following diagrams present examples of SBGN Activity Flow diagrams representing biological activities and their influences among each other in pathway networks. They by no mean exhaust the possibilities of SBGN Activity Flow Level 1.

Figure A.1 presents an example of a signaling pathway involving the regulation of TGF β -induced metastasis. The pathway was described in a report titled "A Mutant-p53/Smad Complex Opposes p63 to Empower TGF β -Induced Metastasis" in the April issue of Cell [16]. The figure shows the usage of *biological activity nodes*, *phenotype*, *positive influence arc*, *negative influence arc*, *necessary stimulation arc*, and *logic operator*.

Figure A.2 on the next page presents a more complicated example of signaling pathway involving the intracellular signaling through the epidermal growth factor receptor (EGFR). This example is a redraw of the Epidermal Growth Factor Receptor Pathway described in the

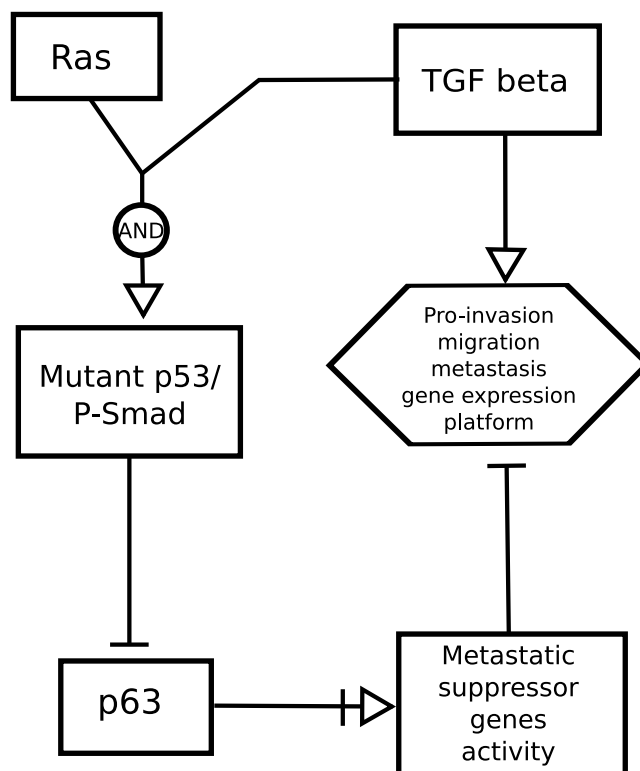

Figure A.1: Regulation of TGF β -induced metastasis.

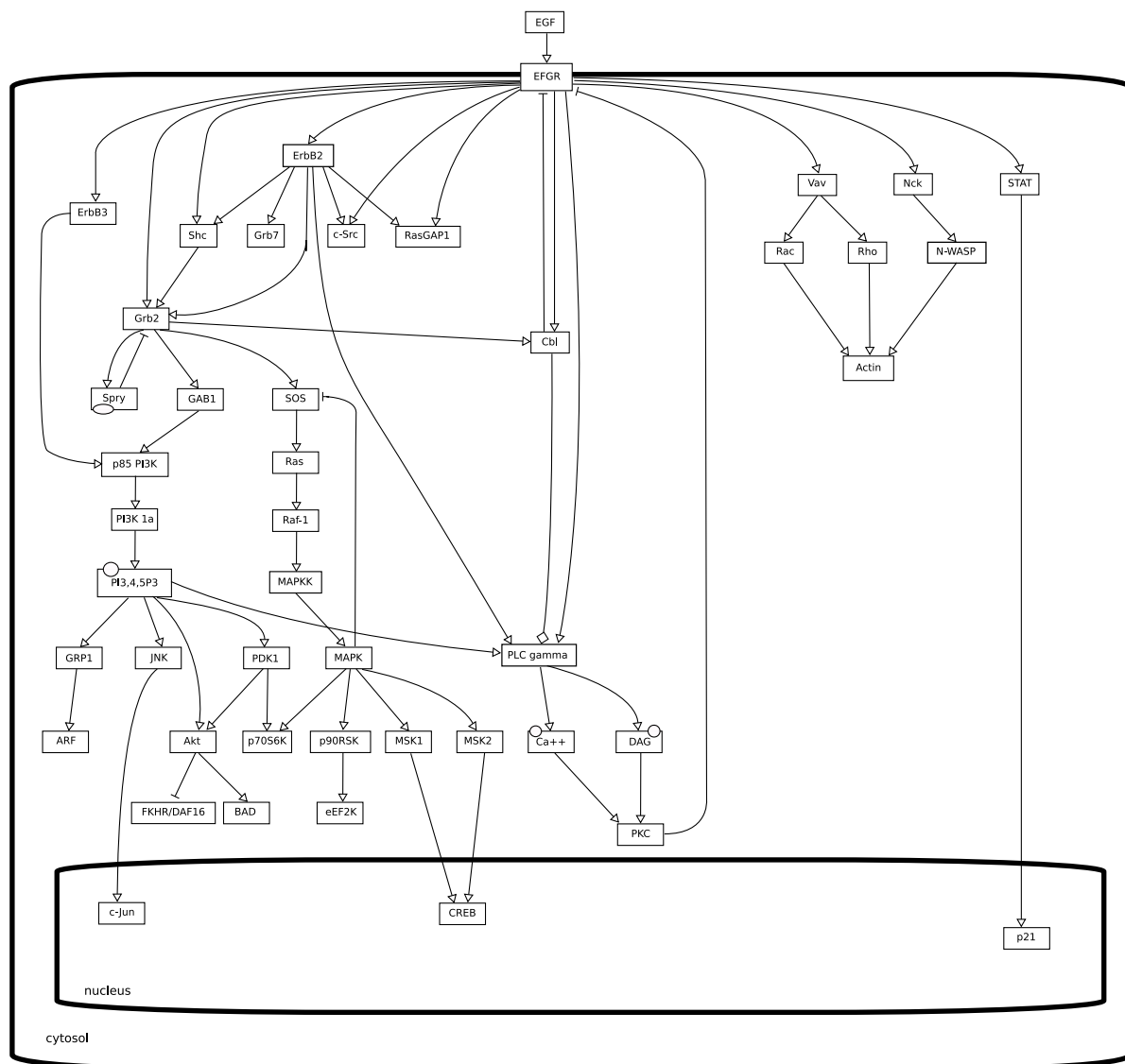

Figure A.2: Epidermal Growth Factor Receptor Pathway.

Signal Transduction Knowledge Environment (http://stke.sciencemag.org/cgi/cm/stkecm;CMP_14554).

Figure A.3 on the following page shows the transforming growth factor beta ($TGF\beta$) signaling pathway. The map is a redraw of the TRG-beta Signaling Pathway described in the PANTHER Pathway System (<http://www.pantherdb.org/pathway/pathwayDiagram.jsp?catAccession=P00052>) and is based on reviews by Massague [17] and Derynck [18].

Figure A.4 on page 35 presents the simplest view of action potential propagation mediated by the voltage-gated sodium channels. There are two views how voltage-gated sodium channels are involved. The diagram on the left side shows that the *increase in membrane potential* activates *voltage-gated sodium channel activity*, which in turn triggers *membrane depolarization*. The diagram on the right side provides more detail in the mechanism. It shows that the *increase in membrane potential* first activates the *gating activity* of the channel, which in turn activates the *conductance activity* leading to the *membrane depolarization*. In this case, both *gating activity* and *conductance activity* come from the sodium channel gene, which is indicated as the *unit of information*. In addition, this example also shows the advantage of using Activity Flow maps,

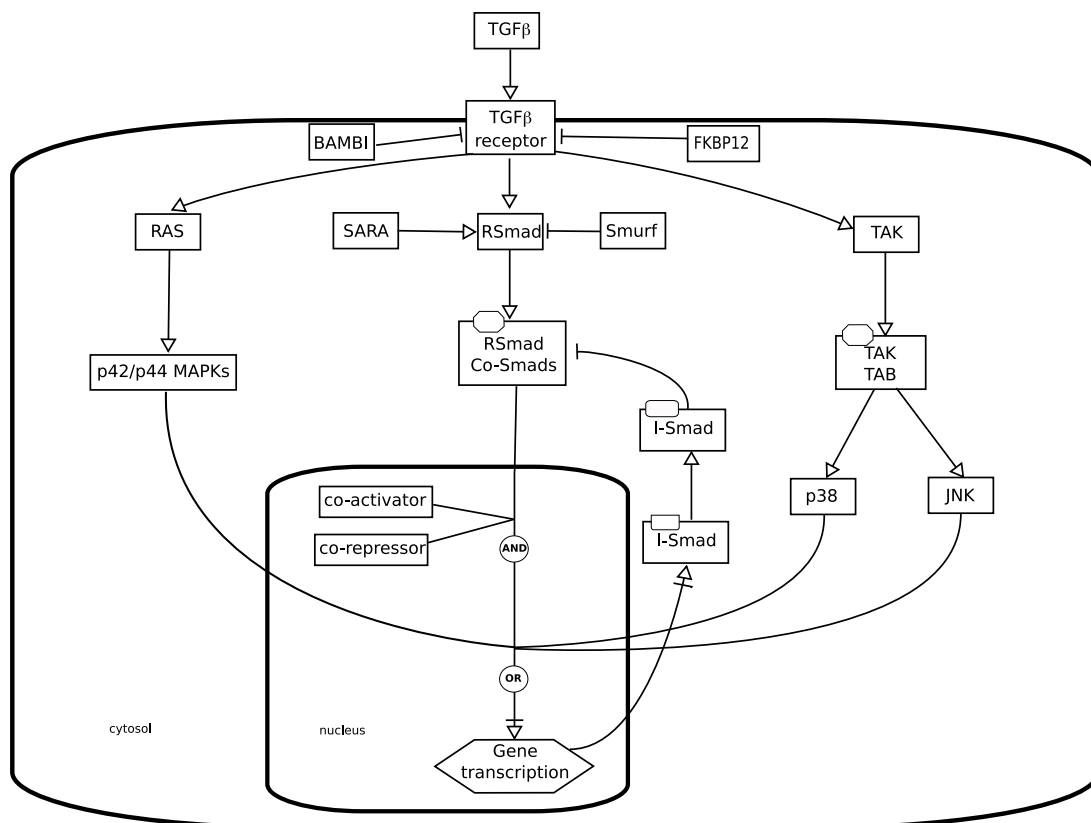

Figure A.3: Transforming Growth Factor beta signaling pathway.

because certain activities, such as gating and conductance, come from a number of amino acids in particular three dimensional structure that are not able to be illustrated in either Process Description or Entity Relationship maps.

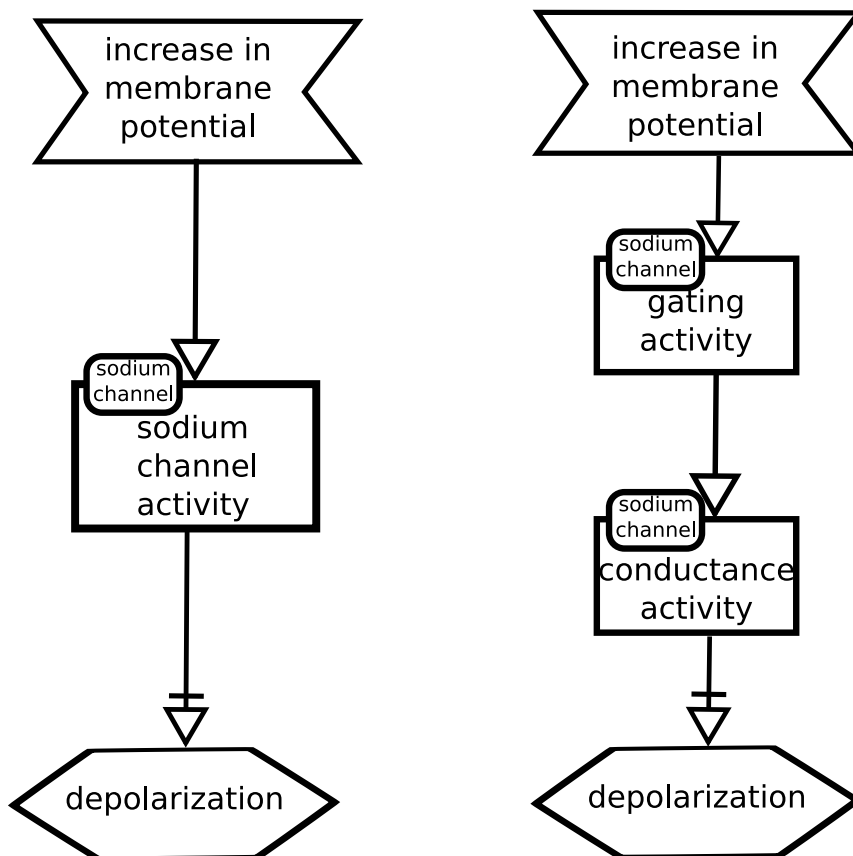

Figure A.4: Two views of the role voltage-gated sodium channel plays in action potential generation illustrated by SBGN Activity Flow Level 1.

Appendix B

Reference card

Print this summary of SBGN Activity Flow symbols for a quick reference.

SYSTEMS BIOLOGY GRAPHICAL NOTATION ACTIVITY FLOW DIAGRAM REFERENCE CARD

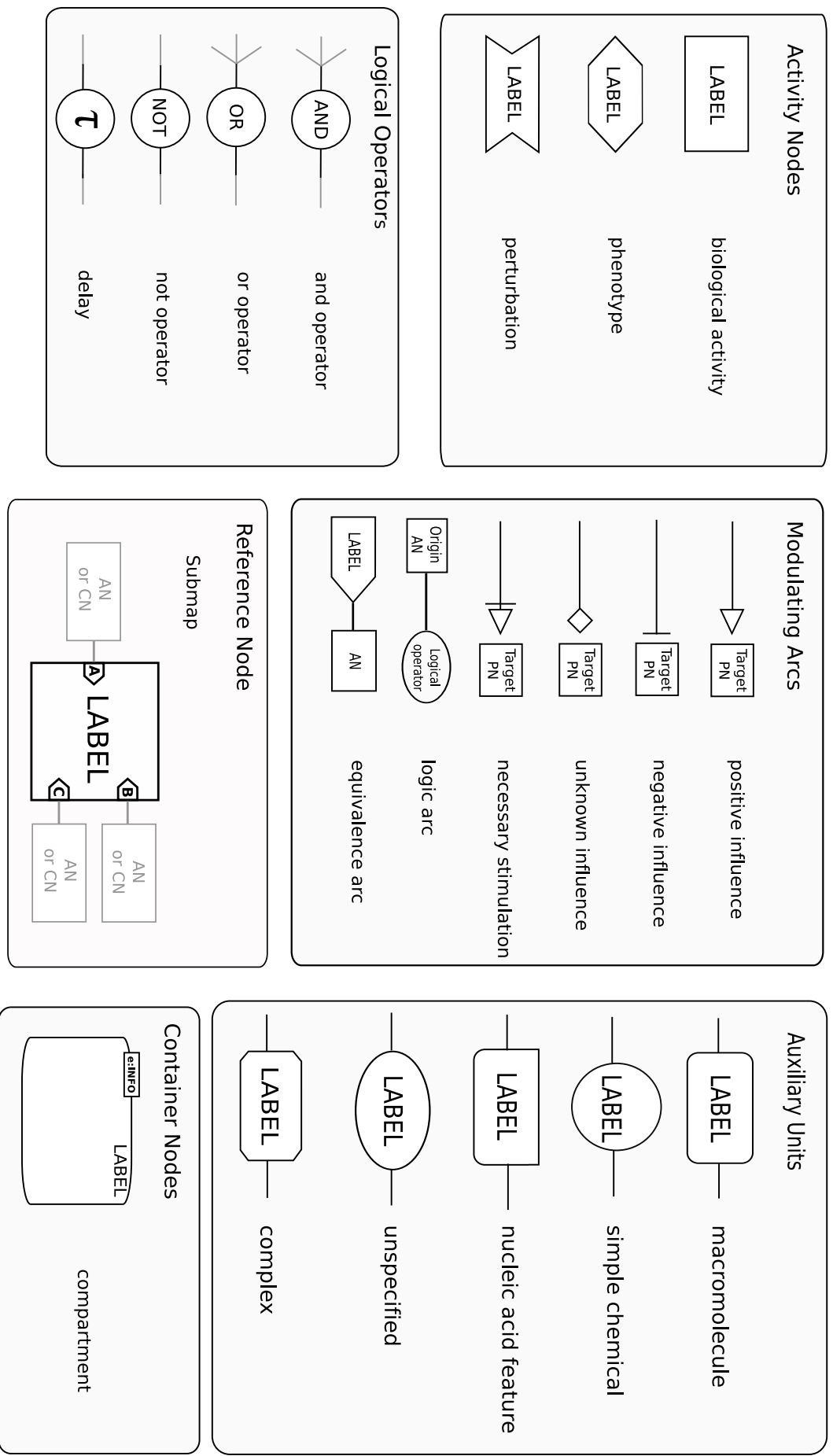

Bibliography

- [1] G. Michal. On representation of metabolic pathways. *BioSystems*, 47:1–7, 1998.
- [2] K. W. Kohn. Molecular interaction map of the mammalian cell cycle control and DNA repair systems. *Molecular Biology of the Cell*, 10(8):2703–2734, 1999.
- [3] P. P.-S. Chen. The entity-relationship model – toward a unified view of data. *ACM Transactions on Database Systems*, 1(1):9–36, 1976.
- [4] I. Pirson, N. Fortemaison, C. Jacobs, S. Dremier, J. E. Dumont, and C. Maenhaut. The visual display of regulatory information and networks. *Trends in Cell Biology*, 10(10):404–408, 2000.
- [5] D. L. Cook, J. F. Farley, and S. J. Tapscott. A basis for a visual language for describing, archiving and analyzing functional models of complex biological systems. *Genome Biology*, 2(4):R0012.1–R0012.10, 2001.
- [6] E. Demir, O. Babur, U Dogrusoz., A. Gursoy, G. Nisanci, R. Cetin-Atalay, and M. Ozturk. Patika: an integrated visual environment for collaborative construction and analysis of cellular pathways. *Bioinformatics*, 18(7):996–1003, 2002.
- [7] E. Demir, O. Babur, U. Dogrusoz, A. Gursoy, A. Ayaz, G. Gulesir, G. Nisanci, and R. Cetin-Atalay. An ontology for collaborative construction and analysis of cellular pathways. *Bioinformatics*, 20(3):349–356, 2004.
- [8] R. Maimon and S. Browning. Diagrammatic notation and computational structure of gene networks. In H. Kitano, editor, *Proceedings of the 2nd International Conference on Systems Biology*, pages 311–317, Madison, WI, 2001. Omnipress.
- [9] H. Kitano. A graphical notation for biochemical networks. *BioSilico*, 1:169–176, 2003.
- [10] H. Kitano, A. Funahashi, Y. Matsuoka, and K. Oda. Using process diagrams for the graphical representation of biological networks. *Nature Biotechnology*, 23(8):961–966, 2005.
- [11] S. L. Moodie, A. A. Sorokin, I. Goryanin, and P. Ghazal. A graphical notation to describe the logical interactions of biological pathways. *Journal of Integrative Bioinformatics*, 3:36.1–36.11, 2006.
- [12] M. Hucka, A. Finney, H. M. Sauro, H. Bolouri, J. C. Doyle, H. Kitano, A. P. Arkin, B. J. Bornstein, D. Bray, A. Cornish-Bowden, A. A. Cuellar, S. Dronov, E. D. Gilles, M. Ginkel, V. Gor, I. I. Goryanin, W. J. Hedley, T. C. Hodgman, J.-H. Hofmeyr, P. J. Hunter, N. S. Juty, J. L. Kasberger, A. Kremling, U. Kummer, N. Le Novère, L. M. Loew, D. Lucio, P. Mendes, E. Minch, E. D. Mjolsness, Y. Nakayama, M. R. Nelson, P. F. Nielsen, T. Sakurada, J. C. Schaff, B. E. Shapiro, T. S. Shimizu, H. D. Spence, J. Stelling, K. Takahashi, M. Tomita, J. Wagner, and J. Wang. The Systems Biology Markup Language (SBML): A medium for representation and exchange of biochemical network models. *Bioinformatics*, 19(4):524–531, 2003.

- [13] D. Pan, M. Fujimoto, A. Lopes, and Y. Wang. Twist-1 is a ppar δ -inducible, negative-feedback regulator of pgc-1 α in brown fat metabolism. *Cell*, 137(1):73–86, 2009.
- [14] G. Di Battista, P. Eades, R. Tamassia, and I. G. Tollis. *Graph Drawing: Algorithms for the Visualization of Graphs*. Prentice Hall, New Jersey, 1998.
- [15] M. Kaufmann and D. Wagner. *Drawing Graphs: Methods and Models*, volume 2025 of *Lecture Notes in Computer Science Tutorial*. Springer, 2001.
- [16] M. Adorno, M. Cordenonsi, M. Montagner, S. Dupont, C. Wong, B. Hann, A. Solari, S. Bobisse, M. B. Rondina, V. Guzzardo, A. R. Parenti, A. Rosato, S. Bicciato, A. Balmain, and S. Piccolo. A mutant-p53/smad complex opposes p63 to empower tgfbeta-induced metastasis. *Cell*, 137(1):87–98, 2009.
- [17] J. Massague. Tgf-beta signal transduction. *Annu Rev Biochem*, 67:753–791, 1998.
- [18] R. Derynck, R. J. Akhurst, and A. Balmain. Tgf-beta signaling in tumor suppression and cancer progression. *Nature Genetics*, 29(2):117–129, 2001.