

NASA/TM-2020-220558

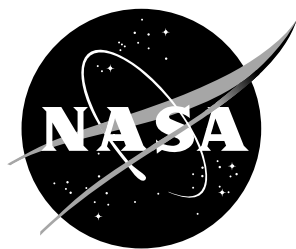

Aircraft Analysis Using the Layered and Extensible Aircraft Performance System (LEAPS)

Francisco M. Capristan
Langley Research Center, Hampton, Virginia

Darrell Caldwell, Ryan Condotta, and Bryan Petty
Analytical Mechanics Associates, Inc., Hampton, Virginia

NASA STI Program... in Profile

Since its founding, NASA has been dedicated to the advancement of aeronautics and space science. The NASA scientific and technical information (STI) program plays a key part in helping NASA maintain this important role.

The NASA STI Program operates under the auspices of the Agency Chief Information Officer. It collects, organizes, provides for archiving, and disseminates NASA's STI. The NASA STI Program provides access to the NASA Aeronautics and Space Database and its public interface, the NASA Technical Report Server, thus providing one of the largest collections of aeronautical and space science STI in the world. Results are published in both non-NASA channels and by NASA in the NASA STI Report Series, which includes the following report types:

- **TECHNICAL PUBLICATION.** Reports of completed research or a major significant phase of research that present the results of NASA programs and include extensive data or theoretical analysis. Includes compilations of significant scientific and technical data and information deemed to be of continuing reference value. NASA counterpart of peer-reviewed formal professional papers, but having less stringent limitations on manuscript length and extent of graphic presentations.
- **TECHNICAL MEMORANDUM.** Scientific and technical findings that are preliminary or of specialized interest, e.g., quick release reports, working papers, and bibliographies that contain minimal annotation. Does not contain extensive analysis.
- **CONTRACTOR REPORT.** Scientific and technical findings by NASA-sponsored contractors and grantees.

- **CONFERENCE PUBLICATION.** Collected papers from scientific and technical conferences, symposia, seminars, or other meetings sponsored or co-sponsored by NASA.
- **SPECIAL PUBLICATION.** Scientific, technical, or historical information from NASA programs, projects, and missions, often concerned with subjects having substantial public interest.
- **TECHNICAL TRANSLATION.** English-language translations of foreign scientific and technical material pertinent to NASA's mission.

Specialized services also include organizing and publishing research results, distributing specialized research announcements and feeds, providing information desk and personal search support, and enabling data exchange services.

For more information about the NASA STI Program, see the following:

- Access the NASA STI program home page at <http://www.sti.nasa.gov>
- E-mail your question to help@sti.nasa.gov
- Phone the NASA STI Information Desk at 757-864-9658
- Write to:
NASA STI Information Desk
Mail Stop 148
NASA Langley Research Center
Hampton, VA 23681-2199

NASA/TM-2020-220558

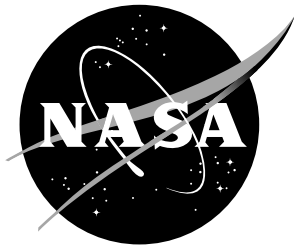

Aircraft Analysis Using the Layered and Extensible Aircraft Performance System (LEAPS)

*Francisco M. Capristan
Langley Research Center, Hampton, Virginia*

*Darrell Caldwell, Ryan Condotta, and Bryan Petty
Analytical Mechanics Associates, Inc., Hampton, Virginia*

National Aeronautics and
Space Administration

Langley Research Center
Hampton, Virginia 23681-2199

February 2020

Acknowledgments

This work was funded by the Transformational Tools and Technologies (TTT) Project, part of the Transformative Aeronautics Concepts Program (TACP), and the Advanced Air Transport Technologies (AATT) Project, part of the Advanced Air Vehicles Program (AAVP) within the Aeronautics Research Mission Directorate (ARMD).

| |
|--|
| Trade names and trademarks are used in this report for identification only. Their usage does not constitute an official endorsement, either expressed or implied, by the National Aeronautics and Space Administration |
|--|

Available from:

NASA STI Program / Mail Stop 148
NASA Langley Research Center
Hampton, VA 23681-2199
Fax: 757-864-6500

Abstract

The Layered and Extensible Aircraft Performance System (LEAPS) is a new aircraft analysis tool being developed by members of the Aeronautics Systems Analysis Branch (ASAB) and the Vehicle Analysis Branch (VAB) at NASA Langley Research Center. LEAPS will enable the analysis of advanced aircraft concepts and architectures that include electric and hybrid-electric propulsion systems. The development of LEAPS is motivated by the analysis gaps found in traditional aircraft analysis tools such as the Flight Optimization System (FLOPS). FLOPS has been the tool of choice of the ASAB for over 30 years and has proven to be a reliable analysis tool for conventional aircraft. However, FLOPS is not suitable to analyze the current unconventional vehicles that are of interest to industry, government agencies, and academia. In contrast, LEAPS is being developed with a flexible architecture that leverages new analysis methodologies that will enable the analysis of unconventional aircraft. This paper presents the first complete working version of LEAPS by showing the analysis of a set of vehicles that include fuel-based and hybrid-electric conceptual aircraft.

1 Introduction

The Layered and Extensible Aircraft Performance System (LEAPS) is a new aircraft analysis tool currently being developed by members of the Aeronautics Systems Analysis Branch (ASAB) and the Vehicle Analysis Branch (VAB) at NASA Langley Research Center [1, 2]. The ASAB has historically relied on the Flight Optimization System (FLOPS) [3] to analyze conceptual aircraft. FLOPS is well suited to analyze conventional tube-and-wing fuel-powered configurations but cannot be readily used to analyze unconventional vehicles and propulsion systems that are of current interest to industry, government agencies, and academia. This paper targets the FLOPS user community and provides an overview of some of the main differences between FLOPS and LEAPS.

Before starting the development of LEAPS, we identified a list of other candidate analysis tools that could be used for conventional and unconventional vehicles. From this analysis we determined that there is a lack of tools that would meet internal customer needs. Furthermore, most tools currently available are not easy to modify, enhance, or extend analysis to account for new technologies. By taking these aspects into consideration, we concluded that the best approach was to design LEAPS with the end goal of being one of the ASAB's next generation aircraft sizing and synthesis tools [1].

FLOPS was initially developed in the early 1980s, and it was constrained by the computational capabilities of that time. For this reason, FLOPS analysis models were designed to use a limited amount of memory and computer power. Despite the computational limitations, the models available in FLOPS have been successfully used for over 30 years because they produce reasonable results in a timely manner with limited computer resources. The increase in computational power in the last 30 years has made FLOPS a suitable tool to perform large number of trade

studies and optimizations because a single analysis often takes less than a couple of seconds. In contrast, some newer aircraft analysis tools designed to study unconventional aircraft can take minutes to perform a single analysis. For this reason, the LEAPS development team decided to include and enhance the appropriate FLOPS methodologies in LEAPS. These methodologies will enable LEAPS to provide analysis of unconventional aircraft without adding significant computational time to each evaluation.

Welstead et al. [1] presented an overview of some of the decisions that guide the software architecture and development of LEAPS. Also, three main goals of the LEAPS development team were highlighted. These goals are:

1. develop a modular, multidisciplinary, multi-fidelity aircraft design and performance software tool;
2. create an aircraft design and analysis tool of exceptional quality and performance; and
3. enable the ease of distribution to the aeronautical community.

In addition, Capristan and Welstead [2, 4] presented the prototype of a mission analysis methodology that has become the base of the methodology in LEAPS. Their work served as a sandbox to test the feasibility of a methodology that allows the analysis of unconventional vehicles and missions.

The main objective of LEAPS is to provide a quality engineering tool to analyze unconventional aircraft configurations. Written in Python 3.7 [5], LEAPS is being designed to be a flexible and modular tool that not only enables the analysis of advanced aircraft concepts but also provides the user with the appropriate software hooks to introduce their own analysis methodologies. When possible, methodologies used previously in FLOPS have been rewritten in Python 3.7 and included in LEAPS. This paper presents the capabilities of LEAPS to fully analyze conventional and unconventional configurations. Because LEAPS is in constant development, the results shown in this paper are not associated with a single version. However, the methodologies and their implementation took place in an incremental manner, so that the main concepts are kept and improved in later iterations.

2 LEAPS Development

The background research and concept exploration began in Fall 2014. This process included talking to different aircraft analysis groups and aircraft analysts to gather their preferences and expertise in what should be included in future analysis tools. Formal software development began in Fall 2016. The initial objective of the software development phase was to translate and update the appropriate FLOPS methodologies to Python 3.7 to include them in LEAPS [1]. The second phase consisted of implementing a mission analysis methodology based on the work performed by Capristan and Welstead [4]. These two phases provide the basic building blocks of the aircraft analysis tool.

2.1 Analysis Models

FLOPS aerodynamics methodology was rewritten in Python 3.7 and introduced as the default methodology in LEAPS. This methodology is based on the Empirical Drag Estimation Technique (EDET) [6]. LEAPS generates a set of aerodynamic tables that are then interpolated to quickly query the desired conditions for analysis.

LEAPS also uses a weight methodology based on FLOPS. This methodology uses data from transport and fighter/attack aircraft [7]. This data was used to produce curve fit equations based on physical characteristics. Details on this methodology can be found in Ref. 8.

The current version of LEAPS does not have internal engine performance routines. LEAPS relies on the user to provide engine performance tables (similar to ‘engine decks’ in FLOPS) to perform sizing studies. These tables are often obtained by using the Numerical Propulsion System (NPSS) [9]. Currently, the LEAPS development team is investigating more direct interfaces with engine performance codes to enhance LEAPS propulsion analysis capabilities.

All of the analysis models presented above are needed to run a mission analysis. It is important to note that approximately 20 aircraft concepts have been used to verify the implementation of the weights and aerodynamics methodologies in LEAPS. The mission analysis used in LEAPS is based on the energy method previously used in FLOPS. The former FLOPS methodology was updated to better handle electric energy sources as well as multiple propulsor classes working at the same time. The main ideas of this methodology are presented in Ref. 4. One of the main advantages of this mission analysis methodology is the possibility of obtaining rapid trajectories where the different segments can be optimized for different objective functions (e.g., time to climb, specific range).

2.2 Capabilities Beyond FLOPS

FLOPS makes numerous assumptions while modeling a vehicle. These assumptions were valid in the past, but they are no longer valid for new concepts that go beyond fuel-powered tube-and-wing configurations. The first assumption is the use of one propulsor class during a mission segment. This assumption is often valid for conventional aircraft, but not for novel configurations that might use different types of propulsors that take advantage of electric power sources such as the STARC-ABL [10] and PEGASUS [11] concepts. Often, analysts have to combine the engine models (engine decks) before performing an analysis to provide a single engine model to FLOPS. This workaround decreases the design space and could hide important tradeoffs regarding the use of the different propulsor classes during a mission [4].

Another important assumption made in FLOPS is that fuel is the only source of energy. This assumption is no longer valid for electric and hybrid-electric vehicles. Different workarounds have been used in the past, where different FLOPS instances had to be coupled together to be able to size batteries in electric and hybrid-electric vehicles [11]. These workarounds can be complex and require the analyst to couple multiple FLOPS instances and files to properly size batteries. LEAPS can handle fuel and electric aircraft without the need of complex workarounds. Also, flight

segments can be optimized to reduce the amount of electric or total energy required. This contrasts with FLOPS fuel-only considerations to fly a segment.

Additionally, the design of LEAPS allows it to be easily used as part of a script. This permits the analyst to modify or add different analysis modules to handle advanced or complex configurations that LEAPS cannot directly handle with an input file. Also, the modularity of LEAPS will allow the end user to manipulate the different analysis models to use them independently or to connect them as desired via Multidisciplinary Design Optimization (MDO) frameworks such as OpenMDAO [12] or ModelCenter [13]. This added flexibility contrasts with limitations seen in FLOPS, where the analyst is often limited with the type of analysis that the developers considered necessary. Other capabilities beyond what FLOPS offers are currently being studied. These include new propulsion and weight analysis models that will allow the analysis of novel configurations that include distributed electric propulsion (DEP).

2.3 Performing an Analysis

LEAPS uses a Python 3.7 environment and requires publicly available third party dependencies. Information regarding installation and running the code can be accessed via the user's guide provided with LEAPS (see Fig. 1). Also, external tools that assist in the conversion of FLOPS input files to LEAPS have been developed.

Layered and Extensible Aircraft Performance System (LEAPS)

Navigation

Contents:

- LEAPS - User's Guide
 - Layered and Extensible Aircraft Performance System (LEAPS) Release 0.0.0
 - INTRODUCTION
 - INSTALLATION
 - USING LEAPS
 - APPENDIX - LEAPS INPUT FILE FORMAT
 - APPENDIX - LEAPS Mission Comparison
 - LEAPS - Output Guide
 - LEAPS - Architecture Guide
 - LEAPS - FLOPS NAMELIST Dictionary
 - LEAPS - FLOPS COMMON Block Dictionary
- Quick search

LEAPS - User's Guide

Layered and Extensible Aircraft Performance System (LEAPS) Release 0.0.0

INTRODUCTION

The Layered and Extensible Aircraft Performance System (LEAPS) is an aircraft sizing and analysis tool being developed by the Aeronautics Systems Analysis Branch at [NASA Langley Research Center](#). The tool is being designed to be highly modular with a multi-order analysis approach in mind that will allow analysts to mix levels of fidelity. Level 0 support will be comprised of the following modules: Weights, Aerodynamics, Propulsion Data and Scaling, Mission Performance, Takeoff and Landing, and Program Control. As development continues, additional levels and modules will be introduced. LEAPS currently supports: Weights, Aerodynamics, Propulsion Data and Scaling, Mission Performance, Simple Takeoff and Landing, and Program Control.

INSTALLATION

Any [Python 3.7](#) environment, or newer, that supports the third party requirements is acceptable. LEAPS was developed using [Miniconda](#). While other versions of these packages may work, LEAPS was developed with the following third party dependencies:

- [SciPy library 1.2.1](#)
- [NumPy 1.16.3](#)
- [Matplotlib 3.0.3](#)

The following directory structure is recommended for installing the LEAPS code base:

- `path/to/LEAPS/code/base` - parent directory of the LEAPS main package directory
 - `leaps` - LEAPS main package directory. **Do not modify the directory structure below this point.**

Figure 1: Snapshot of LEAPS user's guide.

LEAPS is being designed such that in its most basic form a single input file with its respective propulsion data is required to analyze a vehicle. This is similar to the philosophy used in FLOPS and allows the user to easily hand off models to other analysts. The input file structure is simple and easy to understand [1]. Figure 2 shows the comparison between a FLOPS input file and the LEAPS input file. The main differences in the input files are the structure, names, and note aspects. The LEAPS input file is organized more efficiently than its FLOPS counterpart. Another feature of LEAPS is that most aircraft variables in FLOPS can be mapped to LEAPS. This simplifies the transition of models from FLOPS to LEAPS.

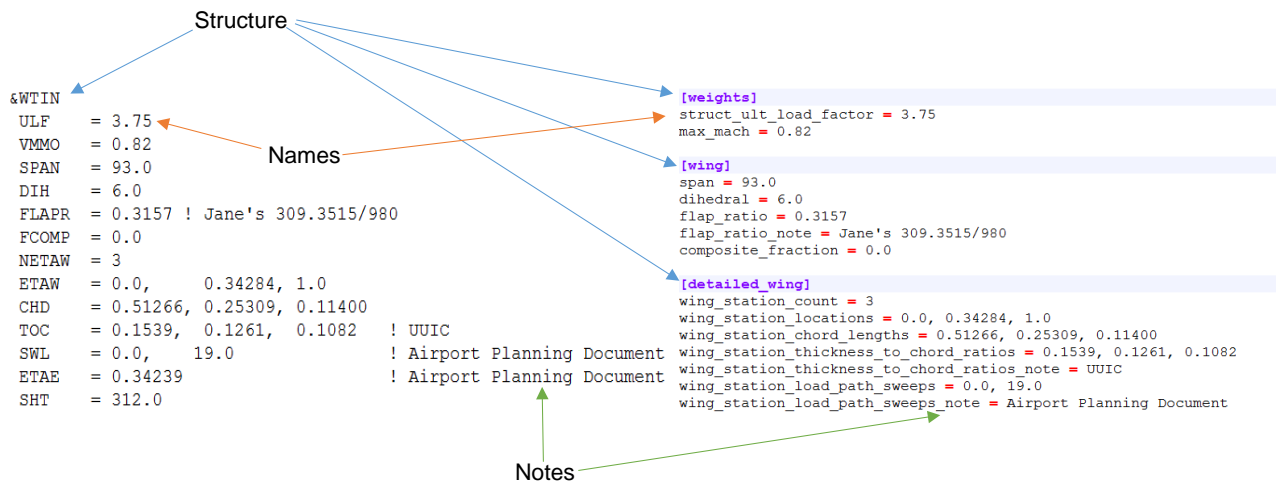

Figure 2: Comparison of legacy FLOPS input file (left) with LEAPS input file(right). Figure from Welstead et al. [1].

Currently, the LEAPS output style and format match closely the FLOPS output. At this stage in development this was preferred to better compare the output from different models being implemented from FLOPS. In addition, LEAPS leverages the use of plotting libraries publicly available to produce mission analysis plots as desired by the user. The output file conveys aerodynamic, weight, propulsion, and mission analysis data. Also, FLOPS users that rely on wrapping the output file from FLOPS will have to perform minor modification to their current text wrapping routines.

3 Analysis Cases

Like FLOPS, LEAPS can analyze fixed-wing aircraft with conventional propulsion systems. A set of test cases are presented in this paper to show the current capabilities and comparisons with respect to FLOPS. The cases analyzed in this paper include a conventional aircraft, and a hybrid-electric aircraft which poses as a challenge vehicle. As mentioned in Section 2.1, LEAPS uses the aerodynamics and weight estimation analysis methodologies used in FLOPS.

The mission analysis methodologies used in LEAPS are based on the energy method used in FLOPS, but are not the same. LEAPS uses publicly available optimizers to determine the desired segment profile. In contrast, FLOPS uses an internal routine that attempts to provide optimal segment profiles. The internal routines used in FLOPS make simplifications that provide quick analysis turnarounds, but do not guarantee that optimality conditions are satisfied. Also, the simplifications used in FLOPS do not allow the analysis of multiple propulsor classes during a flight segment.

3.1 Conventional Aircraft

The first vehicle analyzed was an aircraft model based on the Boeing 737-800. This transport vehicle was modeled using FLOPS and LEAPS. This comparison verified the results of the LEAPS mission analysis methodology in sizing the vehicle for a fixed range.

The first LEAPS case was constrained to emulate the optimized mission obtained from FLOPS. In this test case, the Mach and altitude bounds were allowed to vary in FLOPS. FLOPS then selected the best cruise profile (optimum altitude and Mach number for specific range). As shown in Fig. 3, The FLOPS case flew at a constant altitude and Mach number. This selected altitude and Mach number were then fed into LEAPS, which allowed the comparison of the overall sizing of the vehicle while making sure that the LEAPS and FLOPS trajectories are similar. Note that the second climb, cruise, and descent segments shown by LEAPS L0 in Fig. 3 represent the reserve mission that FLOPS analyzes but does not provide in the output. A weight summary is shown in Table 1. The slight differences in weight can be attributed to slight differences in the reserve mission modeled, and by the the different interpolation scheme to obtain the propulsion data from the engine model (engine deck).

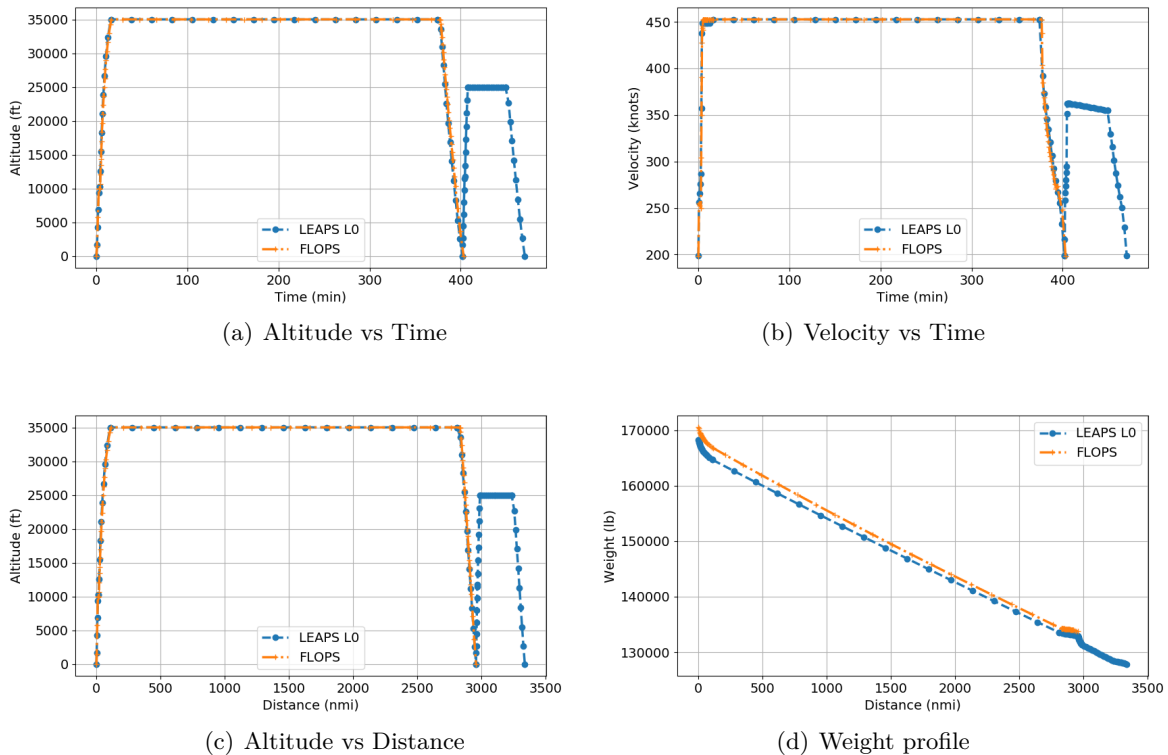

Figure 3: Boeing 737-800 like vehicle mission comparison. LEAPS bounded to match FLOPS trajectory.

Table 1: Weight Comparison for Boeing 737-800-like aircraft.

| | FLOPS | LEAPS | % diff |
|------------------|---------|---------|--------|
| Zero Fuel Weight | 127,971 | 127,868 | 0.08 |
| Mission Fuel | 42,565 | 40,406 | 5.1 |
| Ramp Weight | 170,536 | 168,274 | 1.3 |

The second case evaluated with LEAPS used the same altitude and Mach number bounds for the cruise segment as FLOPS (optimum altitude and Mach number for specific range). The fuel used to complete this mission was 39,689 lb, an 800 lb decrease from the LEAPS case that was aligned to match FLOPS. The results are shown in Fig. 4. The discrepancy in cruise profiles is due to the different mission analysis methodology and the use of different optimizers.

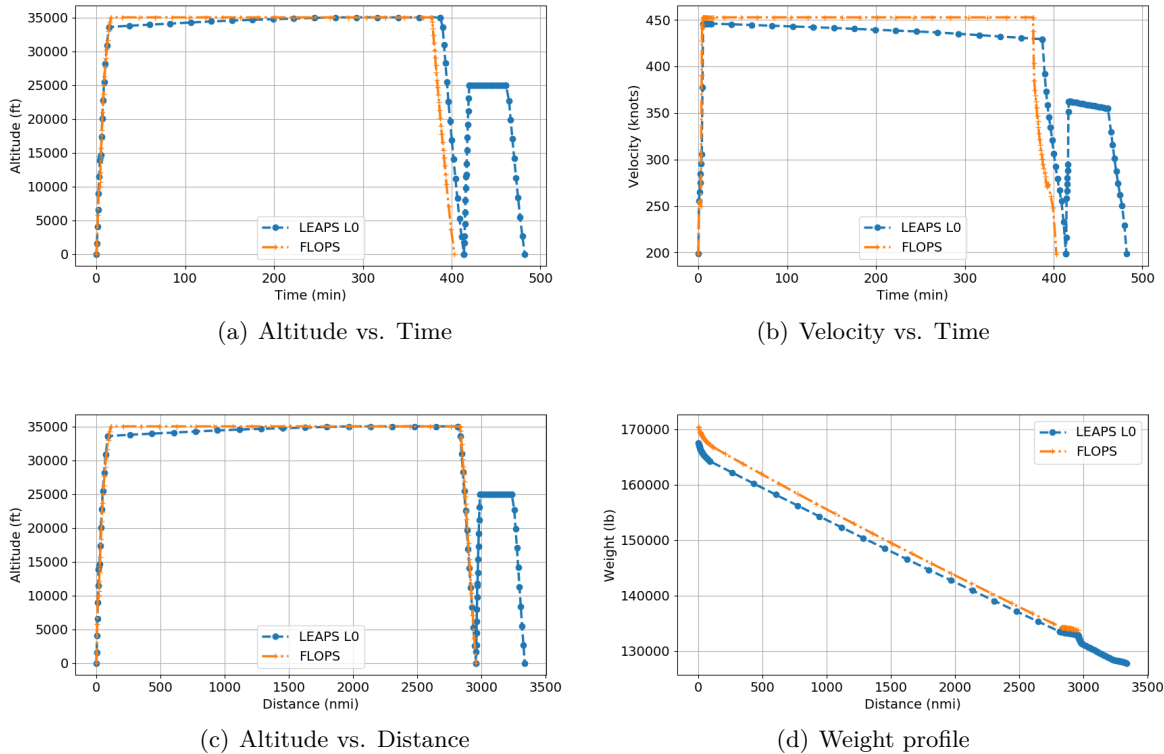

Figure 4: Boeing 737-800 like vehicle mission comparison. LEAPS case uses similar optimization input parameters as FLOPS.

FLOPS uses internal optimization-like methodologies that are quick and provide reasonable cruise flight conditions that consider specific range or fuel. In contrast, LEAPS uses actual optimization routines to compute the desired flight conditions. For this reason, LEAPS mission profiles could provide flight conditions that meet the optimization criteria better than FLOPS; however, this also requires the use of more computational power.

3.2 Hybrid-Electric Aircraft

3.2.1 Mission Analysis Comparison FLOPS vs. LEAPS

FLOPS was designed to analyze fuel-based vehicles. For this reason, workarounds are required to analyze vehicles that use alternate energy sources such as batteries. The vehicle selected to evaluate LEAPS capabilities to analyze hybrid-electric aircraft was the Parallel Electric-Gas Architecture with Synergistic Utilization Scheme (PEGASUS) shown in Fig. 5. This vehicle is a regional aircraft concept that uses electric and hybrid-electric propulsors located strategically to obtain aerodynamic and mission benefits. The hybrid-electric propulsors located at the wingtip provide most of the thrust during cruise and their location in the wing has the potential to reduce induced drag. The inboard propulsors provide additional thrust required during takeoff and climb. The aft propulsor provides further aerodynamic benefits by ingesting and re-energizing the fuselage boundary layer [11]. Three missions are used to size the PEGASUS concept. The first one is a hybrid-electric mission of 400 nmi, the second is an electric-only mission of 200 nmi, and a reserve mission of approximately 300 nmi.

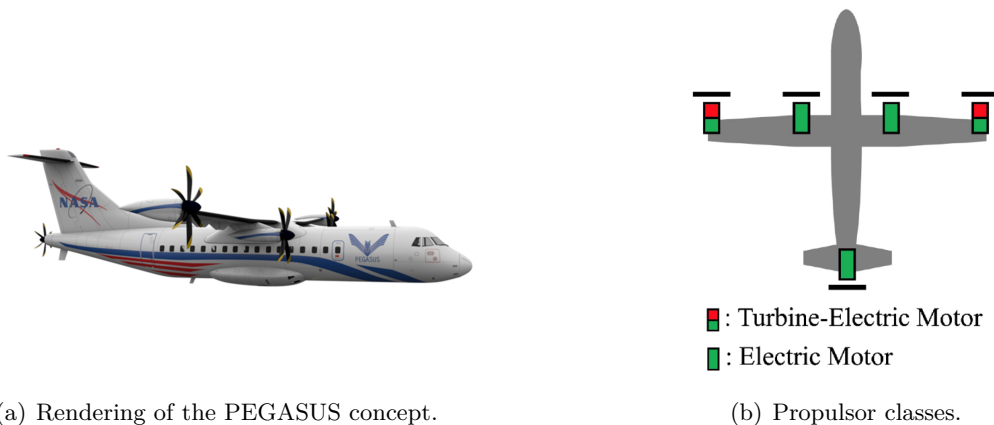

Figure 5: PEGASUS concept.

PEGASUS has three different propulsor classes that can operate at the same time during a mission. FLOPS does not have the modeling capabilities to analyze this type of system without making major simplifications or assumptions. One of the major assumptions is that the three propulsor classes behave as a single propulsor class. All engine models need to be combined into a single model before the mission is analyzed; thus, it is possible that the design space is not properly evaluated. Another modeling limitation is the fact that FLOPS can only optimize a cruise segment by looking into fuel flow used; it does not consider the potential use of other sources such as electric power. Furthermore, FLOPS cannot readily size the battery needed without the use of workarounds. These modeling limitations are handled by LEAPS as previously mentioned in Sec. 2.2.

A direct comparison of LEAPS and FLOPS for the PEGASUS concept is not

possible because FLOPS cannot handle the multiple propulsor classes independently. For this reason, a simplified approach was used to perform a direct comparison. In this simplified approach, all propulsor classes were combined to form a single propulsor class (see Fig. 6). This new engine model is then used in FLOPS and LEAPS to compare the potential vehicle profile. The hybrid-electric mission obtained in this comparison is shown in Fig. 7. The main objective of this paper is to present the modeling capabilities of LEAPS and not to provide detailed sizing information of the PEGASUS vehicle. The sized vehicle can vary depending on the assumptions currently used and thus it is likely going to differ from the final version of the vehicle.

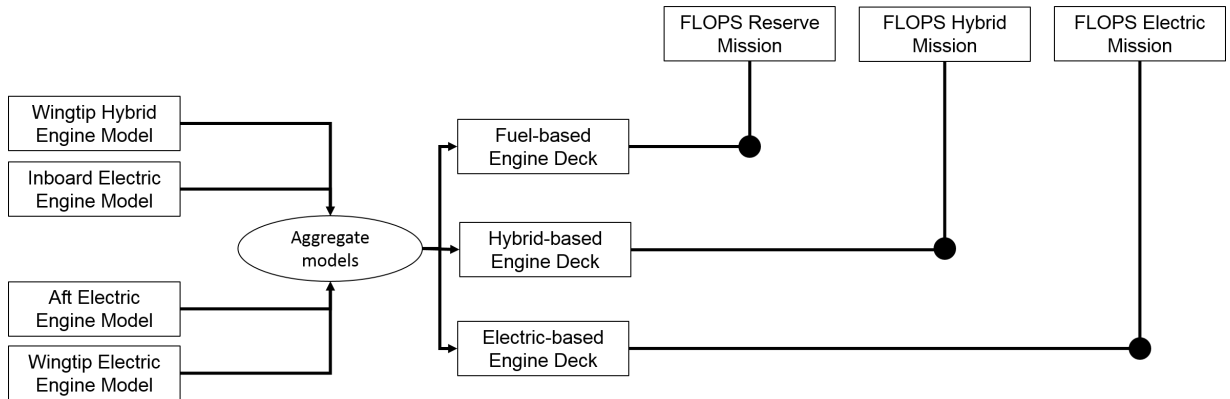

Figure 6: Simplified PEGASUS model used to compare FLOPS and LEAPS.

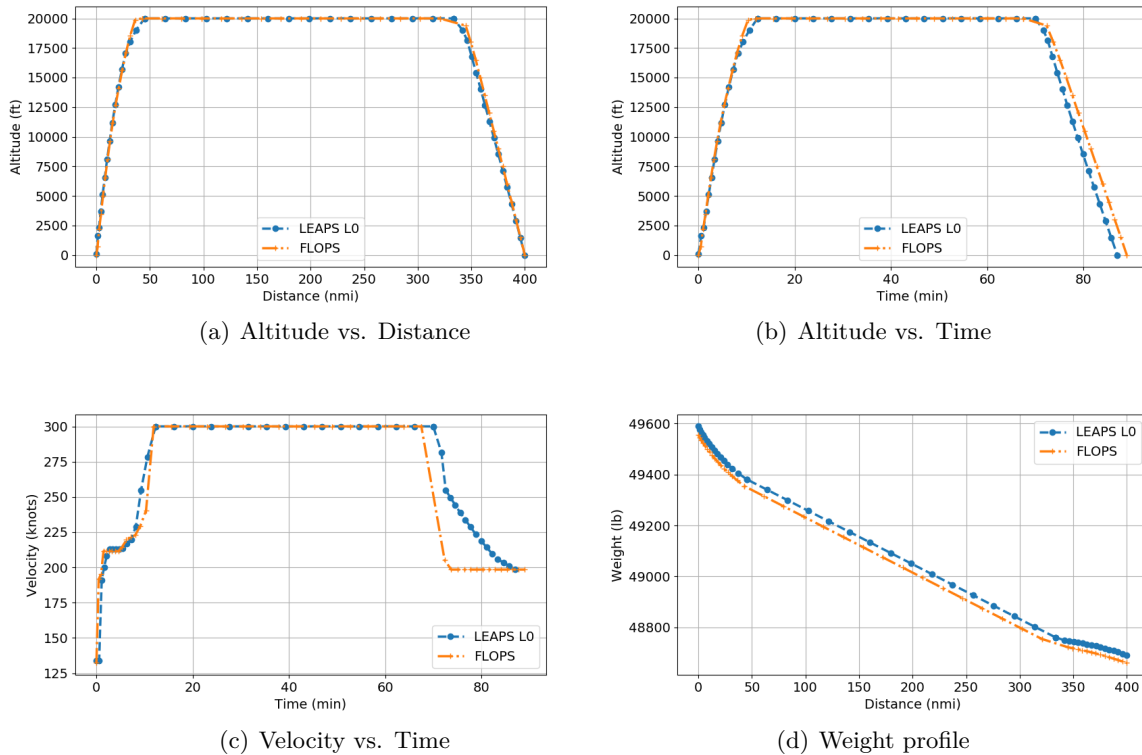

Figure 7: Comparison of FLOPS and LEAPS for a simplified PEGASUS analysis methodology.

3.2.2 LEAPS Analysis

A previous study (see Ref. 14) has used a different prototype of the LEAPS mission analysis methodology to size the PEGASUS aircraft. In this work, the PEGASUS aircraft was sized by using LEAPS. Because of the unconventional mission, LEAPS cannot size the aircraft by using only the input file. In this case, LEAPS was used as a Python 3.7 module which allowed sizing the aircraft without the need of complex wrappers. The aircraft and its mission are defined by an input file. LEAPS reads the input files and a simple wrapper handles the entire vehicle sizing without the need of further I/O wrapping routines.

Different engine models are required to analyze the PEGASUS concept. Two types of models (electric and hybrid) for the wingtip propulsors, one for the inboard propulsors, and one for the aft propulsor. The engine models used for each mission analyzed are shown in Fig. 8. As mentioned earlier, this type of analysis approach cannot be performed in FLOPS.

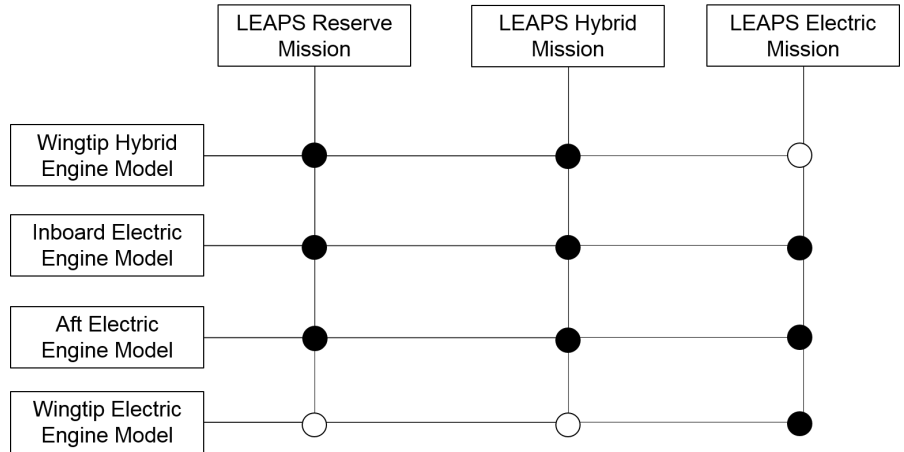

Figure 8: Engine models used in the different mission analysis performed for the PEGASUS aircraft.

Figures 9 to 11 show the profile for the hybrid electric, electric, and reserve missions for the PEGASUS configuration.

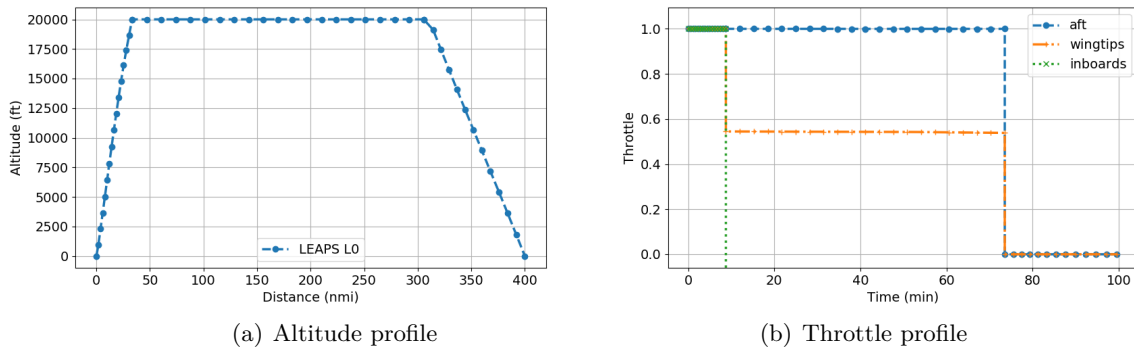

Figure 9: Mission profile for the hybrid-electric mission.

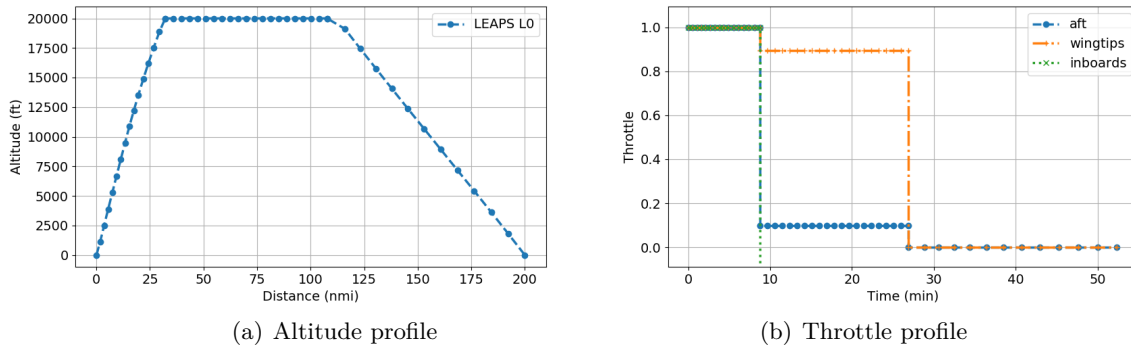

Figure 10: Mission profile for the electric mission.

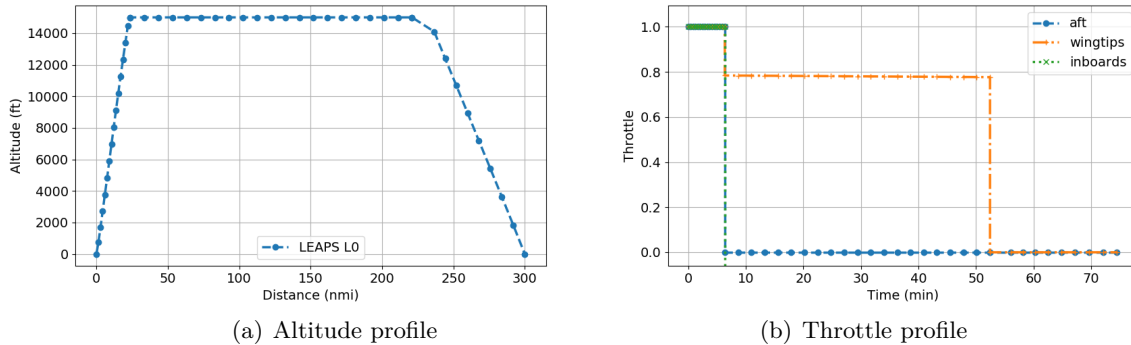

Figure 11: Mission profile for the reserve mission.

4 Concluding Remarks

The first version of the Layered and Extensible Aircraft Performance System (LEAPS) has been completed. This version leverages the weights and aerodynamic methodologies previously used in the Flight Optimization System (FLOPS). These methodologies have been used to analyze many aircraft concepts for over 30 years. In addition, a mission analysis methodology that can analyze unconventional electric and hybrid-electric aircraft has been developed and implemented in LEAPS.

LEAPS has been verified with FLOPS for a set of transport aircraft. This paper presents results for a 737-800-like aircraft. The results show that there are minor discrepancies between LEAPS and FLOPS that are due to the different mission analysis methodology used. These discrepancies were expected, and overall, the comparisons provide good agreement between LEAPS and FLOPS.

The Parallel Electric-Gas Architecture with Synergistic Utilization Scheme (PEGASUS) concept was used to test the hybrid-electric capabilities in LEAPS. Because FLOPS cannot properly analyze this type of vehicle, a simplified model was generated and compared. Overall, the results show agreement, but there are discrepancies

due to the differences in the mission analysis methodology. A more advanced model was also analyzed with LEAPS. FLOPS is not able to analyze such model, so a comparison was not possible. The results show that LEAPS can analyze different propulsor classes working at the same time during a mission segment. Also, a simple wrapper that used LEAPS as a Python 3.7 module was developed to analyze this concept.

The results suggest that LEAPS is comparable to FLOPS when analyzing conventional aircraft, while providing major advancements in the analysis of electric and hybrid-electric aircraft. LEAPS allows a more in depth analysis of unconventional aircraft and simplifies the work-arounds that are often required by conventional aircraft analysis tools like FLOPS. Also, the flexibility of LEAPS simplifies the type of analysis wrappers that might be required to study unconventional aircraft and/or missions.

References

1. Welstead, J. R., Caldwell, D., Condotta, R., and Monroe, N., “An Overview of the Layered and Extensible Aircraft Performance System (LEAPS) Development,” *2018 AIAA Aerospace Sciences Meeting*, AIAA SciTech Forum, American Institute of Aeronautics and Astronautics, Jan. 2018.
2. Capristan, F. M. and Welstead, J., “LEAPS: An Initial Assessment Towards a Multi-Order Approach to Air Vehicle Mission Analysis,” *18th AIAA/ISSMO Multidisciplinary Analysis and Optimization Conference*, AIAA AVIATION Forum, American Institute of Aeronautics and Astronautics, Jun 2017, doi:10.2514/6.2017-4325.
3. McMullers, L., *Flight Optimization System, FLOPS. User’s Guide, release 8.23*, Hampton, VA, 2011.
4. Capristan, F. M. and Welstead, J. R., “An Energy-Based Low-Order Approach for Mission Analysis of Air Vehicles in LEAPS,” *2018 AIAA Aerospace Sciences Meeting*, AIAA SciTech Forum, American Institute of Aeronautics and Astronautics, Jan. 2018.
5. Python Software Foundation, “Python,” Online. <https://www.python.org/>, 2019.
6. Feagin, R. C. and Morrison, W. D., “Delta method, An Empirical Drag Buildup Technique,” *NASA Technical Report*, Vol. NASA-CR-151971, LR-27975-VOL-1, 1978.
7. McCullers, L. A., “Aircraft Configuration Optimization including Optimized Flight Profiles,” NASA. Langley Research Center Recent Experiences in Multidisciplinary Analysis and Optimization, Part 1., Hampton, VA, 1984.
8. Wells, D. P., Horvath, B. L., and McCullers, L. A., “The Flight Optimization System Weights Estimation Method,” Tech. rep., NASA Langley Research Center, 2017, NASA/TM-2017-219627/VOL1, L-20820, NF1676L-27097.
9. NASA, “NPSS Numerical Propulsion System Simulation,” 2019.
10. Welstead, J. and Felder, J. L., “Conceptual Design of a Single-Aisle Turboelectric Commercial Transport with Fuselage Boundary Layer Ingestion,” *54th AIAA Aerospace Sciences Meeting*, No. January, 2016, pp. 1–17.
11. Antcliff, K. R. and Capristan, F. M., “Conceptual Design of the Parallel Electric-Gas Architecture with Synergistic Utilization Scheme (PEGASUS) Concept,” *18th AIAA/ISSMO Multidisciplinary Analysis and Optimization Conference*, AIAA AVIATION Forum, American Institute of Aeronautics and Astronautics, Jun 2017, doi:10.2514/6.2017-4001.
12. Moore, K., Naylor, B., and Gray, J., “The Development of an Open Source Framework for Multidisciplinary Analysis and Optimization,” *12th*

AIAA/ISSMO Multidisciplinary Analysis and Optimization Conference, Multidisciplinary Analysis Optimization Conferences, American Institute of Aeronautics and Astronautics, Sept. 2008, doi:10.2514/6.2008-6069.

13. Phoenix Integration Inc., “ModelCenter,” 2018.
14. Capristan, F. M. and Blaesser, N. J., “Analysis of the Parallel Electric-Gas Architecture with Synergistic Utilization Scheme (PEGASUS) Concept,” *NASA/TM-2019-220396, L-21042, NF1676-33672*, August 2019.

REPORT DOCUMENTATION PAGE

*Form Approved
OMB No. 0704-0188*

The public reporting burden for this collection of information is estimated to average 1 hour per response, including the time for reviewing instructions, searching existing data sources, gathering and maintaining the data needed, and completing and reviewing the collection of information. Send comments regarding this burden estimate or any other aspect of this collection of information, including suggestions for reducing this burden, to Department of Defense, Washington Headquarters Services, Directorate for Information Operations and Reports (0704-0188), 1215 Jefferson Davis Highway, Suite 1204, Arlington, VA 22202-4302. Respondents should be aware that notwithstanding any other provision of law, no person shall be subject to any penalty for failing to comply with a collection of information if it does not display a currently valid OMB control number.
PLEASE DO NOT RETURN YOUR FORM TO THE ABOVE ADDRESS.

| | | | | | |
|---|--------------------|---|-----------------------------------|--|--|
| 1. REPORT DATE (DD-MM-YYYY) 01-02-2020 | | 2. REPORT TYPE Technical Memorandum | | 3. DATES COVERED (From - To) | |
| 4. TITLE AND SUBTITLE Aircraft Analysis Using the Layered and Extensible Aircraft Performance System (LEAPS) | | | | 5a. CONTRACT NUMBER | |
| | | | | 5b. GRANT NUMBER | |
| | | | | 5c. PROGRAM ELEMENT NUMBER | |
| 6. AUTHOR(S) Francisco M. Capristan, Darrell Caldwell, Ryan Condotta, and Bryan Petty | | | | 5d. PROJECT NUMBER | |
| | | | | 5e. TASK NUMBER | |
| | | | | 5f. WORK UNIT NUMBER | |
| 7. PERFORMING ORGANIZATION NAME(S) AND ADDRESS(ES) NASA Langley Research Center Hampton, Virginia 23681-2199 | | | | 8. PERFORMING ORGANIZATION REPORT NUMBER L-21107 | |
| 9. SPONSORING/MONITORING AGENCY NAME(S) AND ADDRESS(ES) National Aeronautics and Space Administration Washington, DC 20546-0001 | | | | 10. SPONSOR/MONITOR'S ACRONYM(S) NASA | |
| | | | | 11. SPONSOR/MONITOR'S REPORT NUMBER(S) NASA/TM-2020-220558 | |
| 12. DISTRIBUTION/AVAILABILITY STATEMENT Unclassified-Unlimited Subject Category 01 Availability: NASA STI Program (757) 864-9658 | | | | | |
| 13. SUPPLEMENTARY NOTES . | | | | | |
| 14. ABSTRACT The Layered and Extensible Aircraft Performance System (LEAPS) is a new aircraft analysis tool being developed by members of the Aeronautics Systems Analysis Branch (ASAB) and the Vehicle Analysis Branch (VAB) at NASA Langley Research Center. LEAPS will enable the analysis of advanced aircraft concepts and architectures that include electric and hybrid-electric propulsion systems. The development of LEAPS is motivated by the analysis gaps found in traditional aircraft analysis tools such as the Flight Optimization System (FLOPS). FLOPS has been the tool of choice of the ASAB for over 30 years and has proven to be a reliable analysis tool for conventional aircraft. However, FLOPS is not suitable to analyze the current unconventional vehicles that are of interest to industry, government agencies, and academia. In contrast, LEAPS is being developed with a flexible architecture that leverages new analysis methodologies that will enable the analysis of unconventional aircraft. This paper presents the first complete working version of LEAPS by showing the analysis of a set of vehicles that include fuel-based and hybrid-electric conceptual aircraft. | | | | | |
| 15. SUBJECT TERMS Aeronautics, Aircraft Design | | | | | |
| 16. SECURITY CLASSIFICATION OF: | | | 17. LIMITATION OF ABSTRACT | 18. NUMBER OF PAGES | 19a. NAME OF RESPONSIBLE PERSON |
| a. REPORT | b. ABSTRACT | c. THIS PAGE | | | STI Information Desk (help@sti.nasa.gov) |
| U | U | U | UU | 21 | 19b. TELEPHONE NUMBER (Include area code) (757) 864-9658 |