



NATIONAL AERONAUTICS AND SPACE ADMINISTRATION

**MANNED SPACE FLIGHT NETWORK  
TRAINING CENTER**

***STUDENT REFERENCE MANUAL***

***for***

***APOLLO***

***MSFN INDOCTRINATION***

**MT-304-R**

**April 1967**

Prepared for

**GODDARD SPACE FLIGHT CENTER, GREENBELT, MD.**

The material contained in this manual  
is for TRAINING PURPOSES ONLY.

## TABLE OF CONTENTS

<u>Section</u>		<u>Page</u>
I	APOLLO PROGRAM	
	Vehicle Assembly Building, Cape Kennedy	1-1
	Lunar Landing Mission	1-5
II	RADAR SYSTEMS	
	Binary-Octal-Decimal Conversion	2-12
III	SITE CONFIGURATIONS	
IV	USB ANTENNAS, A. P. P.	
	Introduction To The Unified S-Band System	4-1
	Unified S-Band Antennas	4-4
V	UNIFIED S-BAND (UPLINK)	
	Uplink	5-1
VI	UNIFIED S-BAND (DOWNLINK)	
	Downlink	6-1
VII	COMMAND SYSTEMS	
	Apollo Digital Command Systems	7-1
VIII	COMPUTER SUBSYSTEM	
	CP-642B Computer	8-1
	Quick Reference Data	8-7
	2010 Data Transmission Unit	8-11
	1540 Magnetic Tape	8-12
	Univac 1232 Input/Output Console	8-13
	1259 TTY	8-15
	Basic Digital Computer Terminology	8-19
IX	ACQUISITION SYSTEM VHF RECEIVER	
X	TELEMETRY SYSTEMS	
	Principles of Telemetry	10-1
XI	DISPLAYS AND RECORDERS	

TABLE OF CONTENTS (Cont.)

<u>Section</u>		<u>Page</u>
XII	SPACE PROTON ALERT NETWORK	
	Solar Particle Alert Network	12-1
	Apollo Solar Terminology	12-13
XIII	NETWORK COMMUNICATIONS	
XIV	GLOSSARY	

## LIST OF ILLUSTRATIONS

<u>Code</u>	<u>Title</u>	<u>Page</u>
	Section I	
	Vehicle Assembly Building, Cape Kennedy	1-1
AI-003	Complex 39 Launch Pad	1-6
AI-021A	Saturn 1B Launch Vehicle	1-24
AI-032	Saturn V	1-25
AI-001	Apollo Spacecraft Separation Planes	1-26
AI-033	Launch Escape Tower, Command Module, Service Module, and Lunar Module	1-27
AI-002	LM Interface and Explosive Device Locations	1-28
AI-035	Command Service Module	1-29
AI-022	General Arrangement Command Module	1-30
AI-036	Launch Escape System	1-31
AI-005	Abort Separation Functions	1-32
AI-006	Normal Tower Jettison	1-33
AI-004	Earth Ascent Phase Description	1-34
AI-007	Command Service Module/S-IVB Separation	1-35
AI-043	Elapse Time Sequence	1-36
AI-008	Earth Vicinity and Translunar Mission Description	1-37/1-38
AI-009	Lunar Vicinity Mission Description	1-39/1-40
AI-010	LM Descent Phase Description	1-41
AI-011	Lunar Stay Communications	1-42
AI-012	Transearth and Entry Mission Description	1-43/1-44
AI-016	Mains Deployed Reefed	1-45
AI-018	Earth Landing	1-46
AI-019	Recovery	1-47
AI-045	Unified S-Band Stations	1-48
AI-20	Apollo Mission Support Assignments	1-49
AI-042	Network Evolution	1-50

## LIST OF ILLUSTRATIONS (Cont.)

<u>Code</u>	<u>Title</u>	<u>Page</u>
Section II		
RDS-002	Radar Set AN/MPS-26 (XN-1) Trailer	2-1
RDS-001	FPS-16 Antenna Pedestal	2-2
RDS-008	FPQ-6 Radar Antenna	2-3
RDF-014	Pointing Data for Network Radars	2-4
RDF-007	Azimuth, Elevation Angles and Slant Range in the Radar Plane	2-5
RDS-005	13-Bit Optical Encoder	2-6
RDS-004	8-Bit Mechanical Encoder	2-7
RDS-003	Radar Set AN/FPS-16, Block Diagram	2-8
RDF-005	Digital-To-Teletype Converter	2-9
RDF-001	Radar Tracking System Without D-C Analog Data Transmission	2-10
RDF-002	Radar Tracking System With D-C Analog Data Transmission	2-11
Section III		
AI-031	Remote Station Configuration	3-1/3-2
AI-041	Apollo Ships, Block Diagram	3-3/3-4
AI-040	Apollo Aircraft Relay	3-5
Section IV		
AI-107	Simplified Apollo Unified S-Band System	4-3
PAS-001	Typical USB Layout	4-7
ALB-011	30-Foot Antenna Structure	4-8
AI-101	USB Land Based Antennas, Technical Characteristics	4-9
AI-114	Land Antenna Performance	4-10
ALB-019	30-Foot Antenna Servo Drive, Block Diagram	4-11
ALB-005	Antenna Servo Control Console Layout	4-12
ALB-023	Antenna Servo Control Unit	4-13

LIST OF ILLUSTRATIONS (Cont.)

<u>Code</u>	<u>Title</u>	<u>Page</u>
Section IV (Cont.)		
AI-102	USB System 30-Foot Antenna Facility	4-14
APP-101	Antenna Position Programmer, Subsystem, Block Diagram	4-15
APP-102	USB System Antenna Position Programmer	4-16
APP-103	Antenna Position Programmer	4-17
APP-107	Antenna Position Programmer Control Panel (Local)	4-18
APP-106	Antenna Position Programmer Control Panel (Remote)	4-19
SBA-100A	30-Foot USB Shipboard Antenna	4-20
SBA-100B	12-Foot USB Shipboard Antenna	4-21
AI-101	USB Shipboard Antenna, Technical Characteristics	4-22
SBA-164	Antenna Feed System	4-24
SBA-115	SB-42 Control Console	4-25
Section V		
R&E-101	S-Band Frequency Chart	5-2
R&E-102	USB Individual Uplink	5-3
R&E-103	USB Dual Uplink	5-4
AI-046A	Uplink, Signal Flow	5-5
APP-302	Up-data Buffer, Block Diagram	5-6
AI-059	Subcarrier Oscillator Subsystem	5-7
PAS-101	USB Power Amplifier Group 11-076, Block Diagram	5-8
AI-025	Ground System Characteristics	5-9
ATS-001	Apollo Precision Frequency Source	5-10
AI-104	Time Standard, Block Diagram	5-11
Section VI		
R&E-101	S-Band Frequency Chart	6-3
R&E-104	USB CSM Downlink	6-4
AI-028	Spacecraft Transponder	6-5

## LIST OF ILLUSTRATIONS (Cont.)

<u>Code</u>	<u>Title</u>	<u>Page</u>
Section VI (Cont.)		
AI-052	Spacecraft To Ground Communications Requirement	6-6
AI-053	CSM Transmission Combination Summary (PM Mode)	6-7
AI-054	CSM Transmission Combination Summary (FM Mode)	6-8
AI-055	Downlink CSM, Block Diagram	6-9
R&E-105	LM Downlink	6-10
AI-056	LM Transmission Combination Summary	6-11
AI-057	LM S-Band System	6-12
R&E-106	Emergency Key	6-13
R&E-107	Emergency Voice	6-14
AI-026	Spacecraft Systems	6-15
AI-030	Two-Way Lock	6-16
AI-047	Downlink, Signal Flow	6-17
AI-050	Data Demodulator, Block Diagram	6-18
RRR-003	Transmit Code Generator, Block Diagram	6-19
RRR-002	Code Acquisition, Timing Diagram	6-20
AI-113	USB System Tracking Data Processor	6-21
AI-116	USB 30-Ft. Antenna Station, Block Diagram	6-22
AI-117	USB 85-Ft. Antenna Facility Primary Stations	6-23
AI-115	USB 85-Ft. Antenna Facility Secondary Stations	6-24
Section VII		
AI-024	Command Word Structure (Stored and/or Real Time)	7-3
AI-119	Apollo Digital Command System	7-4
AI-118	Typical Remote Site Command Data Flow, Block Diagram	7-5
Section VIII		
AI-120	Apollo Data Processing System, Block Diagram	8-9/8-10



## LIST OF ILLUSTRATIONS (Cont.)

<u>Code</u>	<u>Title</u>	<u>Page</u>
Section VIII (Cont.)		
RSDP-1002-A	Block Diagram, 1232 Console	8-14
AI-121	Block Diagram Of Site Without Flight Control Console	8-16
AI-122	Block Diagram, Console/Computer Interface Adapter	8-16
ADS-001	Apollo Display System Pictorial Diagram	8-18
Section IX		
AAT-001	Simplified Systems Integration	9-1
VSR-001	Simplified Acquisition Aid System, Block Diagram	9-2
Section X		
PCM-001A	Simplified Telemetry System, Block Diagram	10-20
PCM-001	FM/FM Multiplexing	10-21
PCM-018	Block Diagram, Typical PCM System	10-22
PCM-002	Periodic Sampling	10-23
PCM-003	Sampling For Time Multiplexing	10-24
PCM-005	Wheel Diagram of PCM-003 and PCM-004	10-25
PCM-006	Wheel Diagram and Corresponding Matrix	10-26
PCM-021	Pulse Code Modulation Techniques	10-27
AI-125	Typical Remote Site Telemetry Data Flow Block Diagram	10-28
Section XI		
ADS-005	Command Communicator Console	11-1
ADS-006	Systems Monitor Console	11-2
ADS-007	Aeromedical Console	11-3
ADS-008	Flight Dynamics Officer's Console	11-4
ADS-001	Apollo Display System, Pictorial Diagram	11-5
ARS-125	Apollo Recorder, Model 22, Full Front View	11-6
ARS-100	Model 22, Tape Transport, Front View	11-7
ARS-309	Sanborn Recording System, Model 958D	11-8

LIST OF ILLUSTRATIONS (Cont.)

Code	Title	Page
Section XII		
ROT-001	Radiation Spectrum	12-4
ROT-020	Layers of the Sun	12-5
AI-1203	SPAN Observatory	12-6
ROT-080	Manned Lunar Flight	12-7
ROT-120	Solar Optical Telescope, Major Units and Systems	12-8
ROT-140	Selector Disc	12-9
ROT-100	Solar Optical Telescope, Block Diagram	12-10
ROT-220	Radio Telescope Antenna System, Rear View	12-11
ROT-200	Solar Radio Telescope, Block Diagram	12-12
Section XIII		
TTO-001	MSFN Network Interface	13-1
TTO-003	494 Comm. Processor Interface System	13-2
TTO-004	112A Key System Call Director	13-3
AI-150	Apollo Communications Network Configuration	13-4

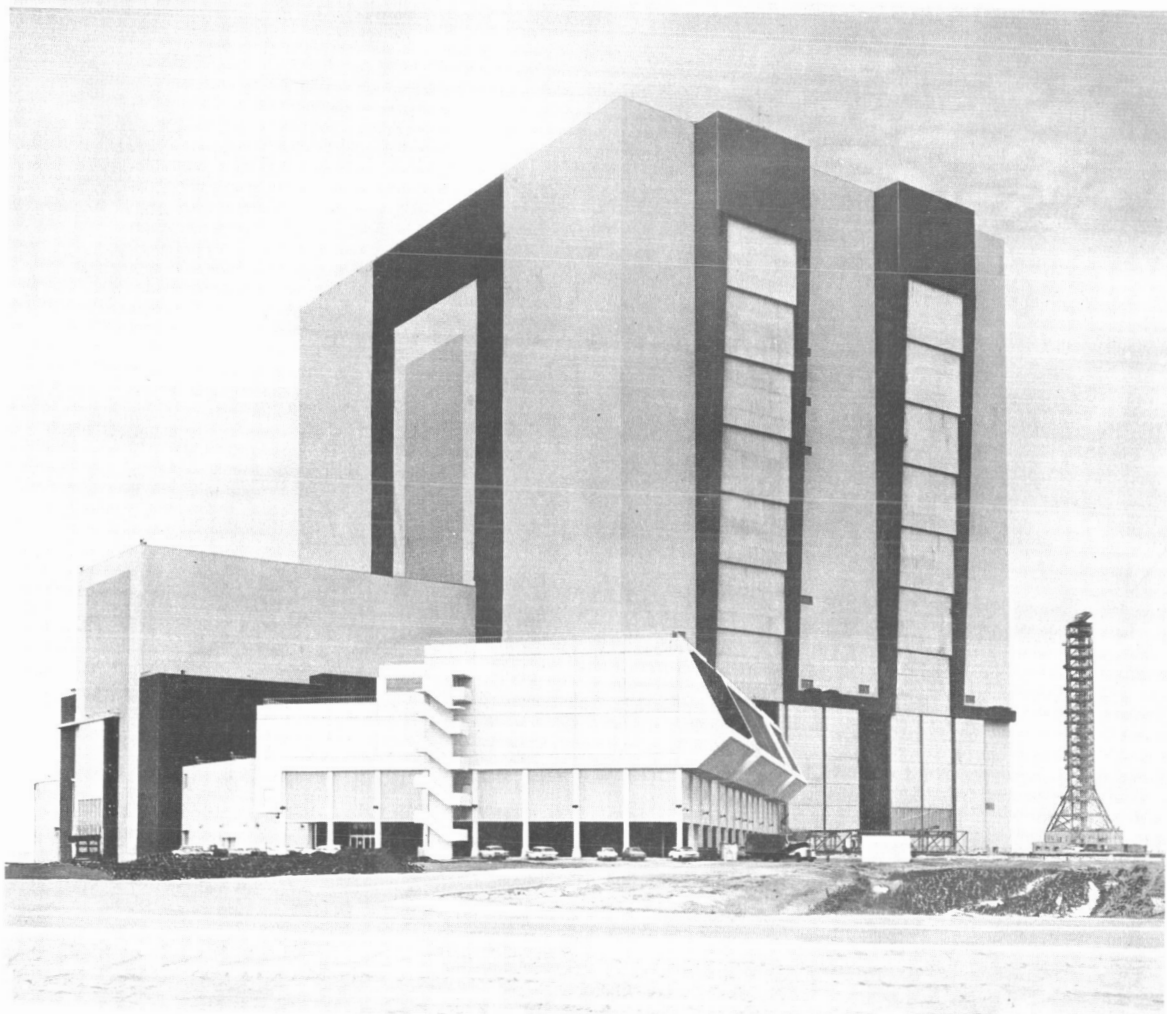

Vehicle Assembly Building, Cape Kennedy

Since the pledge by the late President John F. Kennedy that Americans would walk the lunar surface in this decade, many scientific people are combating the numerous problems which must be overcome before his pledge can be fulfilled. The first of these problems was to erect a building in which to assemble the huge Saturn V rocket and associated equipment plus a vehicle to transport the rocket to the launch pad.

Engineers had to plan on a building approximately eight acres in size and with side walls that would withstand winds up to 125 miles an hour. Also, the building would have to be high enough to accommodate a rocket service tower 45 stories high that could be picked up and moved. In addition, they would need a vehicle that would carry a tremendous load and a roadway that would not crumble under the

immense weight. The combining of many thoughts and talents of approximately 200 engineers helped to overcome the difficulties and start the Apollo project on its way.

Towering over the flat landscape of Merritt Island, Florida, across the Banana River from the launch towers of Cape Kennedy, is one of man's greatest architectural achievements--the Vehicle Assembly Building (VAB). This is the building where the Saturn V rocket and the Apollo spacecraft will be assembled and prepared under controlled conditions for sending American astronauts on the most daring adventure ever conceived--the long journey through space to the moon.

The size of the building gives one a first impression of utter disbelief. For example, the VAB could house the Pentagon, the world's largest office building, and have nearly enough room to house another one just like it.

In the vast confines of its interior, which is open from the floor to the rafters, four football games could be played simultaneously. The building can also create its own weather.

There are 10,000 tons of air-conditioning units to cool and circulate the air, changing it completely once each hour. Without this constant circulation a drop in temperature of only five degrees would cause clouds to form in the airy heights of the rafters and the building would be deluged by a rainstorm of its own making.

The mammoth building has four doors. Each of these doors is so large that a 45-story building could be moved through it. Placed horizontally, a door would completely cover a two-acre field.

Inside the door, there is a Saturn V rocket 360 feet tall mounted on a platform along with a 380-foot service tower. With the Apollo spacecraft mounted atop the rocket, the complete assembly towers more than 400 feet upward toward the rafters and weighs 12 million pounds.

The Saturn is 100 times more powerful than the Redstone rocket used for the Mercury project and 17 times mightier than the Titan 2 that boosts the two-man Gemini spacecraft into orbit. It gulps 30,000 pounds of volatile fuels a second and delivers a thrust of 7.5 million pounds.

Once the rocket has been assembled and the spacecraft fitted in place inside the Vehicle Assembly Building, the complete package (platform, rocket and spacecraft, and service tower) must be transported to the launch pad. A huge monstrous thing that looks like a gargantuan turtle with a shell as big as a baseball diamond has been built to accomplish this. By use of huge jacks, the entire platform can be lowered onto the transporting vehicle.

The roadway between the VAB and the launch pad is as broad as the New Jersey Turnpike and stronger than any other built in the world. This roadway is three miles long, and it takes the monstrous transporting vehicle three hours to haul its ponderous load to the launch pad.

Before construction could begin on the huge Vehicle Assembly Building, the soggy swampland had to be transformed to firm ground. This was accomplished by use of sand dredged from the Banana River and piled 46 feet deep over the building site. This sand was allowed to settle for three months, exerting its weight on the swampland, squeezing out the water.

.Then the sand was bulldozed away and pile drivers drove 4,225 steel rods, each 16 inches in diameter, down into bedrock 150 to 170 feet deep. The steel anchor of the building was capped by reinforced concrete seven feet thick.

Enough steel to build 30,000 automobiles makes up the framework which, in turn, is enclosed by a million square feet of aluminum siding--the biggest and heaviest sheets ever rolled from a mill.

The Vehicle Assembly Building is truly an architectural fantasy on the inside. It has been described this way, "Whole buildings hang from the sides. Some of them move up and down and in and out like suspended file drawers, and mate with one another to form still other buildings-within-buildings to house the space vehicles."

In the past, missiles were pieced together on outdoor pads where they had to withstand rain, wind, and the corrosive salt mists from the Atlantic. But now, for the Apollo project, Saturn rocket sections can arrive at the Vehicle Assembly Building separately and receive preliminary checkouts in what are called "low bays"

(20 stories high). Then a giant crane will be used to lift the 144-ton booster, 52 stories high, and stack the upper stages and the spacecraft on top. All this will now be accomplished under roof.

As Apollo rendezvous missions become commonplace, two rockets may be undergoing the assembly process inside the Vehicle Assembly Building while two others are being prepared for launch from separate pads.

## LUNAR LANDING MISSION

### GENERAL

The Apollo program will culminate in a lunar landing mission. This mission will produce the first manned exploration of the moon. This section contains a sequential presentation of the major events of the lunar landing mission.

### CAPE KENNEDY

The lunar landing mission will originate from Cape Kennedy where facilities are being constructed for precision handling of larger space-exploration vehicles and associated equipment.

The component assemblies of the Apollo spacecraft and the Saturn V launch vehicle will be transported to Cape Kennedy for final assembly tests. The spacecraft and launch vehicle will be assembled (stacked) on the Launch Umbilical Tower (LUT) platform, which is mounted on the crawler-transporter. Assembly takes place in the Vehicle Assembly Building. After assembly is completed, interface and systems tests will be made.

### TRANSPORTATION TO LAUNCH PAD

After operations are concluded in the Vehicle Assembly Building, the assembled LUT, spacecraft, and launch vehicle will be transported to Launch Complex 39. Transportation of the LUT, spacecraft, and launch vehicle will be provided by the crawler-transporter which will carry this load six miles at approximately one mile an hour on a specially constructed crawlerway. The crawlerway to the launch pad is a pair of parallel roadways which can support a load in excess of 17 million pounds.

### LAUNCH PAD

Upon arrival at the launch pad, the crawler-transporter will lower the LUT, platform, spacecraft, and launch vehicle onto steel foundations. The crawler-transporter will move an arming tower onto the pad next to the spacecraft. The

1-6

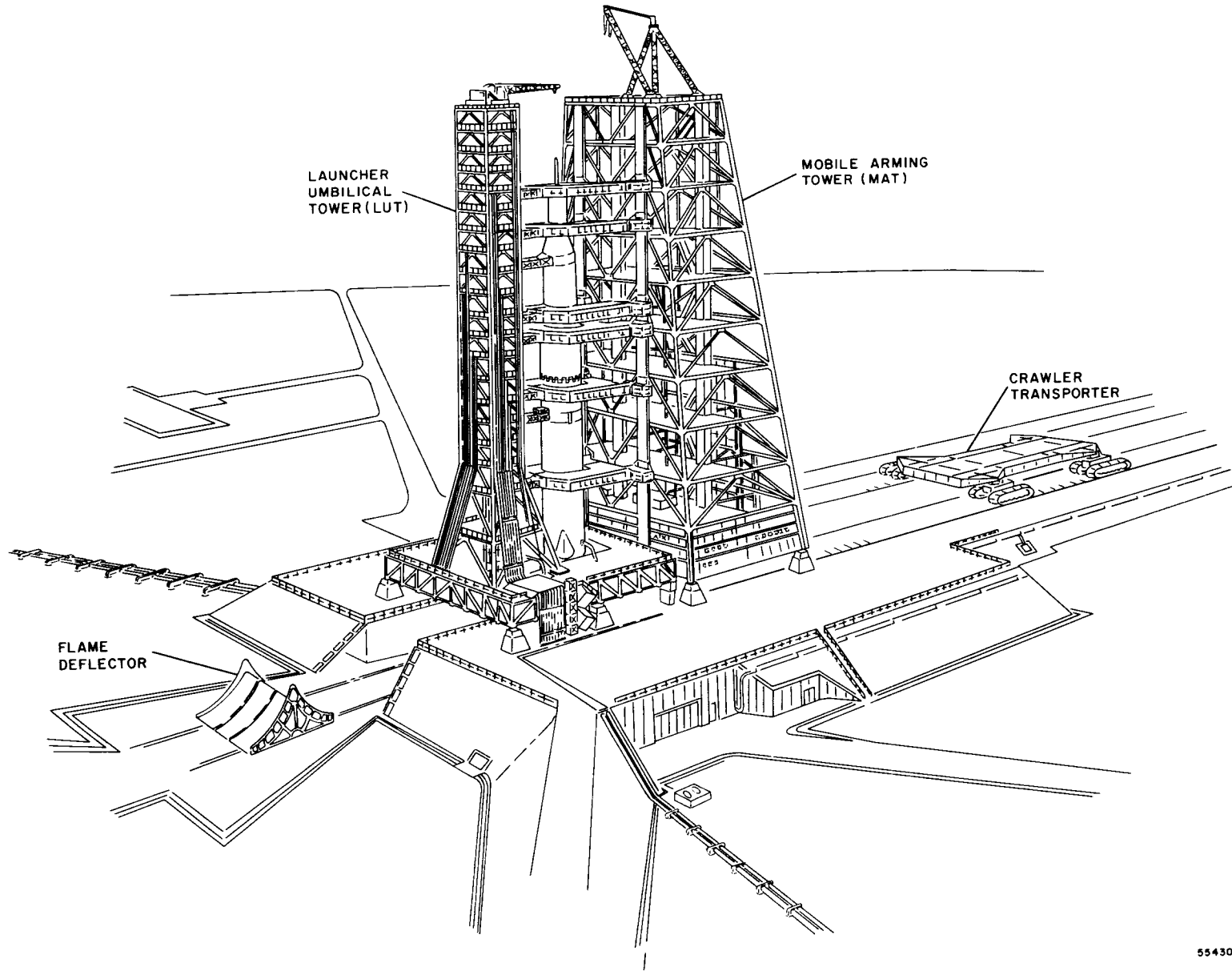

5543004

TRAINING USE ONLY

COMPLEX 39 LAUNCH PAD A1-003



arming tower provides facilities for arming spacecraft explosive components (used in separation operations) and fueling. When the arming tower is no longer needed, the crawler-transporter and the arming tower will be removed from the launch area.

## COUNTDOWN

The final prelaunch countdown sequence begins upon final positioning of the LUT, spacecraft, and launch vehicle on the launch pad. Appropriate protective devices were installed at the time of ordnance installation to prevent inadvertent operational arming and firing of the pyrotechnics and to provide maximum safety for the spacecraft checkout crew and launch area ground personnel.

The prelaunch countdown follows a programmed sequence which is directed and controlled by the launch control director. This sequence establishes the order of required operational checkout of the spacecraft systems and of the servicing and loading of consumable gases, fuels, and supplies.

The countdown sequence consists essentially of the activation or simulated activation and verification checks of the spacecraft operational systems as follows:

- Removal of ground support equipment (GSE)
- Leak checks
- Battery activation
- Final arming of ordnance devices
- Removal of ordnance shorting devices
- Loading of fuels - helium, liquid hydrogen, and liquid oxygen
- Fuel cell activation
- Entry of mission flight crew into command module
- Closing of command module crew hatch
- Installation of boost protective cover hatch access cover
- Command module crew cabin leak check
- Purging the command module cabin with 100-percent oxygen
- Final confidence checks of the spacecraft systems by the crew
- Final arming of the launch escape system
- Ground-to-spacecraft umbilical disconnect

When final checks are completed, the ground-to-spacecraft umbilical cables are disconnected and the launch tower support arms are retracted. Final decision and approval to launch is verified by the launch control center and the spacecraft crew.

## LIFTOFF

Upon launch, the Saturn V first stage (S-IC) engines are ignited by the launch control center. The center engine ignites first, followed by the ignition of the outer four engines. The launch pad hold-down devices release after initial operational thrust is sufficient. The launch control center and the spacecraft crew will continuously monitor the initial operational ascent attitude parameters.

## FIRST-STAGE SEPARATION

The first-stage guidance system initiates roll of the spacecraft to the required launch azimuth. The first-stage pitch programmer initiates the required pitchover of the spacecraft. Voice communication between the crew and the Manned Space Flight Network (MSFN) is maintained through the critical maximum dynamic flight conditions and throughout the ascent phase. The cutoff of the first-stage engines is followed by ignition of the second-stage ullage rockets. The first-stage retro-rocket then separates the first stage from the spacecraft.

## SECOND-STAGE EVENTS

Second-stage (S-II) engine ignition occurs nominally two seconds after cutoff of the first-stage engines at approximately 200,000 feet. The flight trajectory of the spacecraft is controlled by the S-IVB inertial guidance system. The launch escape system is operationally jettisoned at approximately 300,000 feet altitude. The second-stage engines are cut off at an altitude of approximately 600,000 feet. The sequential ignition of the third-stage (S-IVB) ullage rockets, second-stage retrorockets, and third-stage engines effects separation of the second-stage. The third-stage engines provide the thrust required to place the spacecraft in earth orbit. The third-stage guidance control system cuts off the third-stage engines after the programmed orbit conditions have been attained.

## EARTH ORBIT

The spacecraft and third stage are to orbit the earth, no more than three times, at an approximate altitude of 100 nautical miles. During this period, the orbital parameters are determined by landmark navigational sightings, and then verified by the Manned Space Flight Network and the spacecraft crew. This determines the required velocity increment and trajectory for translunar injection.

The crew will perform a biomedical and safety equipment check. Sequence checks will be made of the environmental control system, communications and instrumentation system, service propulsion system, service module reaction control system, electrical power system, guidance and navigation system, stabilization and control system, and crew equipment system.

Translunar injection parameters are determined on-board the spacecraft by sequential landmark navigational sightings (using the scanning telescope) and by the Apollo guidance computer. Trajectory and star-tracking data computations are made by the Apollo guidance computer. The inertial measurement unit is fine-aligned for the translunar injection monitor, using the Apollo guidance computer. The center-of-gravity offset angles are set into the service propulsion system gimbal position display. The delta V program, time, and direction vector are set into the Apollo guidance computer. The stabilization and control system is prepared for the delta V monitor, including minimum deadband hold control and monitor mode. Finally, the third-stage reaction control system is prepared for the delta V translunar injection.

Verification of "go" conditions for translunar injection will be confirmed by the spacecraft crew and the Manned Space Flight Network. The third-stage count-down and ignition sequence is performed with the spacecraft in the required translunar injection attitude.

## TRANSLUNAR INJECTION

The translunar injection phase begins with the third-stage ullage rocket ignition. The third-stage propulsion system is operated to provide sufficient thrust

to place the spacecraft in a translunar "free-return" trajectory in accordance with the delta V magnitude, time duration, and thrust vector previously established and operationally programmed onboard the spacecraft by the crew and confirmed by the Manned Space Flight Network.

The third-stage instrument unit provides operational guidance control for the translunar injection with the Apollo guidance and navigation system capable of backup control, if necessary. The third-stage engines operate for the predetermined time, nominally five minutes. The crew monitors the emergency detection system and spacecraft attitude control displays. The spacecraft guidance and navigation system monitors the programmed injection maneuver.

#### INITIAL TRANSLUNAR COAST

Following translunar injection, the crew will perform an onboard determination of the spacecraft trajectory and verify it with the determination made by the Manned Space Flight Network. The operational controls are then set for an initial coast phase. An onboard systems check is then made of all crew equipment, electrical power system, environmental control system, service module reaction control system, and the service propulsion system. The status of these systems is communicated to MSFN.

The spacecraft body-mounted attitude gyros are aligned, using the third-stage stable platform as a reference, and the flight director attitude indicator is set preparatory to initiating transposition of the lunar excursion module, is made with MSFN.

#### LUNAR EXCURSION MODULE TRANSPOSITION

Transposition of the lunar excursion module consists of separating and translating the command-service module from the lunar excursion module/adaptor/third-stage, pitching the command-service module 180 degrees, and translating the command-service module back to the lunar excursion module to join the lunar excursion module to the command module. The S-IVB guidance system stabilizes the lunar excursion module/adaptor/third-stage during the transposition operations. After completion of docking, the third stage is jettisoned. The entire maneuver will

normally be completed within one hour after translunar injection. Necessary precautions will be observed by the crew during the time that the spacecraft passes through the Van Allen belts.

The spacecraft will be oriented to provide the most desirable background lighting conditions for the transposition of the lunar excursion module. The third-stage is stabilized in an attitude-hold mode. The adapter is pyrotechnically separated from the command-service module, which is then translated approximately 50 feet ahead of the lunar excursion module and third-stage, using the service module reaction control system engines. The command-service module is then rotated 180 degrees in pitch, using the service module reaction control engines. The docking attitude of the command-service module for the lunar excursion module adapter third-stage will be established and maintained by using the service module reaction control system engines.

The command-service module will be translated toward the LM/adapter/third-stage with minimum closing velocity so that the command-service module probe engages with the drogue mechanism on the lunar excursion module. The command-service module with the lunar excursion module attached then separates and translates away from the third-stage.

#### FINAL TRANSLUNAR COAST

The final translunar coast phase begins with the ignition of the service module reaction control system to separate the spacecraft from the third-stage and ends with service module reaction control system ullage acceleration just prior to lunar orbit insertion. The primary operations occurring during this phase consist of system checkout of the spacecraft and lunar excursion module systems, trajectory verifications, and preparations for lunar orbit injection. Midcourse delta V corrections, navigational sightings, and inertial measurement unit alignments are to be made if needed. A delta V budget sufficient to provide a total delta V correction of 300 feet a second is planned.

The spacecraft guidance and navigation system computes the trajectory of the spacecraft (in conjunction with navigational sightings). The delta increment required is determined by MSFN, and confirmation of the trajectory and velocity increment values is made with the Apollo guidance computer. Midcourse incremental velocity corrections will be made if required.

The attitude of the spacecraft will be constrained at times because of operational temperature control restrictions. The crew may enter the lunar excursion module to check its operational capabilities during the final translunar coast phase. At least one astronaut will be in his space suit at all times. A crew work-rest cycle will be established and followed during this phase. The capability to initiate an abort at any time during this phase will be provided.

In preparation for lunar orbit insertion, the spacecraft attitude, lunar orbit insertion velocity increment, and the time to initiate the service propulsion system thrust required to achieve the desired orbit around the moon are determined by trajectory data from MSFN and from the guidance and navigation system. The spacecraft will then be properly oriented and the service module reaction control system ullage rocket ignition will be initiated by the crew.

The initial lunar orbit coast phase begins with cutoff of the service propulsion engine as the spacecraft is inserted into lunar orbit and ends with activation of the lunar excursion module reaction control system to effect separation from the spacecraft.

Following lunar orbit insertion, the crew will transmit trajectory data and information to MSFN. The orbit ephemeris about the moon will be determined as accurately as possible, using the spacecraft guidance system and MSFN. A confirming checkout of the lunar excursion module guidance system is also made prior to separation from the spacecraft.

The spacecraft systems will be capable of operation at their nominal design performance level for a mission of 14 days. A single crew member can control the spacecraft in lunar orbit for 7 days. Communication capability will be provided between the spacecraft, Manned Space Flight Network, and the lunar excursion module

when separated and within line-of-sight. The spacecraft and lunar excursion module separation and docking operations will not be restricted by natural illumination conditions.

Observations and calculations will be made of the preselected landing site from the spacecraft, to determine if the area location is satisfactory or if an alternate landing area should be selected. Detailed surveillance of the landing area is to be made from the lunar excursion module prior to landing.

Lunar orbit trajectory verification requires fine alignment of the inertial measurement unit, and a related series of navigational sightings will be made of known lunar surface areas and reference stars, using the scanning telescope, sextant, Apollo guidance computer, and MSFN, but the LM descent trajectory will be calculated using the computer only.

Upon final confirmation of these parameters, the commander and the systems engineer will transfer from the spacecraft to the lunar excursion module. The lunar excursion module electrical power system, environmental control system, communication system, guidance and navigation system, stabilization and control system, reaction control system, and ascent and descent engine systems will be checked out. A check will be made of emergency procedures and corresponding spacecraft systems. The operational capability to the air lock will be verified. Initial operational information will be synchronized between the spacecraft and lunar excursion module.

The spacecraft will be aligned and held in the required attitude for separation. The lunar excursion module guidance computer will be programmed for the transfer trajectory when the spacecraft orbit is determined accurately. The orbit will not be disturbed, unless an emergency requirement prevails, or until the docking phase is complete. Emergency or additional data may require that the spacecraft lunar orbit be updated as necessary by the remaining crew member.

Actual separation of the module from the spacecraft is effected by a propulsion thrust from the lunar excursion module reaction control system. After a specified time, an equivalent impulse is applied in the opposite direction so that the relative

velocity between the lunar excursion module and the spacecraft will be zero during the final checkout of the lunar excursion module. Final checkout is accomplished with the lunar excursion module in free flight, but relatively close to the spacecraft in case immediate docking is required.

## LUNAR LANDING

The lunar excursion module lunar operations phase begins with initial LM separation from the spacecraft and ends with touchdown of the LM on the surface of the moon.

The essential LM operations which occur are attitude control, incremental velocity control, and time to fire, computed by the LM guidance and navigation system. LM insertion into a descent orbit is accomplished by reaction control system ullage acceleration and ignition of the descent engine with the thrust level and burn-time automatically controlled by the LM guidance and navigation system. The LM separates from the spacecraft during this maneuver, and communication with the Manned Space Flight Network at time of insertion is not possible, since it occurs on the far side of the moon.

Descent trajectory determination will be made using data from rendezvous radar tracking the spacecraft. The LM will coast in descent transfer orbit following descent engine cutoff, and close observation of the proposed lunar landing site will be made for final approval. The descent engine will be reignited prior to reaching the low point in the orbit and sustained thrust initiated for the descent maneuver. The thrust and attitude are controlled by the guidance and navigation system by comparison of the actual and planned landing tracks.

The translational and radial velocities will be reduced to small values and the descent engine will cut off at a specified altitude above the lunar surface. The pilot will manually control the descent within preset limits. Terminal descent and touchdown will be made by manual control and use of the landing radar. Confirmation of initial lunar touchdown will be made by the LM crew to the spacecraft and to MSFN.



The crewman in the spacecraft will maintain visual observation of the lunar landing operation. All three crewmen will be in their space suits.

## LUNAR SURFACE OPERATIONS

The lunar surface operations phase begins with lunar touchdown and ends with launching of the LM from the moon.

Initial tasks to be performed by the two astronauts following touchdown include review and determination of the lunar ascent sequence and of the parameters required. A complete check of the LM systems and structure will be made. Necessary maintenance will be determined and performed to assure the operational ascent capability of the LM. The systems will be put into a lunar-stay mode and a system monitoring procedure established. The LM will be effectively secured as necessary and the landing and launch stage disconnect mechanisms activated.

The lunar landing must be made on the earth-side of the moon to permit and establish communication with MSFN and the lunar orbiting spacecraft from the surface of the moon. Voice and signal communication will be verified prior to beginning egress and lunar exploration activity. A post touchdown-status report will be made to the spacecraft before line-of-sight communication is lost as the spacecraft orbits below the lunar horizon. The position and attitude of the LM on the moon will be established and reported.

The LM is capable of operating normally on the lunar surface during any phase of the lunar day-night cycle. The LM, designed to be left unoccupied with the cabin unpressurized on the lunar surface, will be capable of performing its operations independently of earth-based information or control.

Although the nominal lunar stay-time may be from 4 hours to 35 hours, depending on the planned scientific exploration program, the capability to launch at any time in an emergency situation will be established. Portable life support systems (PLSS) will provide the capability for 24 man-hours of separation from the LM. Maximum continuous separation will be 4 hours (3 hours of normal operation plus 1 hour for contingencies).

One crew member will normally descend to the lunar surface to perform scientific exploration and observation, while the other crew member will remain in the LM to monitor systems status and maintain communications. In the event that certain scientific exploration or experiments require both crewmen, the LM may be left unattended. The scientific exploration activity may include gathering selected samples from the lunar surface and atmosphere, measurement of lunar surface and atmospheric phenomena, and the securing of scientific instruments on the lunar surface for signal transmission and telescope observation from earth. Video transmission from the lunar surface may be accomplished by means of portable television equipment. Provision will be made for return of approximately 80 pounds of samples from the lunar surface.

Following completion of the lunar surface exploration activity, preparation for ascent will begin. The two crewmen will secure themselves in the LM cabin. Launch and rendezvous plans will be confirmed with the crewman in the spacecraft and with MSFN. The spacecraft tracking and rendezvous data determination sequence will be initiated. The LM operational systems required for lunar ascent, the ascent and descent stage separation procedures, and the inertial measurement unit alignment procedures, will be checked out.

#### SPACECRAFT SOLO LUNAR ORBIT OPERATION

During separation of the LM from the spacecraft for lunar operations, the crew member in the spacecraft will perform a series of backup operations in support of the lunar activity.

The spacecraft crew member will initially monitor the separation sequence and initiate radar tracking of the LM. A communication link between the spacecraft, LM, and MSFN will be established. The spacecraft will monitor the LM orbit injection sequence and maintain cognizance of essential operational parameters.

In addition, periodic operational checks will be made of the spacecraft systems, the inertial measurement unit alignment procedure performed, and the lunar orbit parameters periodically updated and confirmed with MSFN.

The lunar landing sequence will be monitored by radar tracking and essential operational data will be transmitted to MSFN. The location of the lunar landing site will be determined. Visual observations will be made of the lunar surface operations and periodic line-of-sight communication with the crew maintained as required.

Spacecraft confirmation of the LM ascent and rendezvous parameters will be established. Radar tracking of the ascent trajectory will be established to permit determination of the operational maneuvers to effect rendezvous and docking. The spacecraft guidance and navigation system determines these essential parameters.

The LM will provide manual control of the terminal attitude and translation required for rendezvous and docking. The spacecraft normally will be stabilized in a passive mode for rendezvous and docking, but it will have the capability of actively performing this operation, if necessary. After completion of docking, the crew will transfer from the LM to the spacecraft.

#### LUNAR ASCENT

Confirmation of "go" conditions for lunar launch is made with the spacecraft and MSFN. The ascent engine will be ignited and launch from the lunar surface accomplished.

The LM ascent trajectory places it in a position approximately 50,000 feet above the lunar surface, at a velocity such that the resultant orbit about the moon has a clear minimum altitude of approximately 50,000 feet and a nominal intercept with the orbiting CSM. The launch trajectory of the LM is controlled through its guidance and navigation system. The LM rendezvous radar tracks the spacecraft during the ascent to provide inputs to the guidance and navigation system. The LM reaction control system executes the required roll attitude and pitch maneuvers to place it in the required orbit.

Following the cutoff of the ascent engine, the radar will continue to track the spacecraft. The spacecraft guidance and navigation system will compute the orbit of the LM and the crew will determine if any delta V corrections are required to

effect rendezvous. The final coast trajectory parameters, range, rate, and attitude angles will be determined and rendezvous operations will be initiated.

## RENDEZVOUS

The rendezvous operations begin during the LM ascent phase. The ascent trajectory may require up to three midcourse corrections to reach a collision course with the CSM. These corrections will be made with either the LM ascent engine or the reaction control system. The final rendezvous maneuvers will include three terminal homing thrusts from the LM reaction control system to reduce the relative velocity to a minimum.

The LM crew will manually control the LM within a range of approximately 500 feet from the spacecraft, with a relative velocity of 5 feet a second or less. Both the spacecraft and the LM are capable of performing the final rendezvous and docking maneuvers required, assuming that the LM orbit has a minimum altitude. The spacecraft is normally stabilized in passive mode with the LM operationally active to effect rendezvous.

The final docking maneuvers of the LM to effect contact with the spacecraft, are performed using the reaction control engines. Docking alignment and closing velocity will be verified and necessary manual operational control established to effect initial engagement of the latching mechanism. Following verification of the initial latching, the final latching sequence will be performed. Completion of hard docking will be verified by both the LM and spacecraft crew members. The post-docking status of the system will be determined and, when the docking maneuver is completed, information will be transmitted to the Manned Space Flight Network.

The rendezvous and docking operations may be accomplished under any natural lunar lighting conditions.

Following completion of hard docking, the LM systems will be secured. The LM crew will then transfer the lunar scientific equipment and samples to the spacecraft and store them in the command module. The two crew members will enter the command module and secure the access hatch between the command module and the lunar excursion module.

A system status check will be made of the spacecraft operational systems and the status for separation from the LM will be communicated to MSFN. The sequence for separation will then be initiated. The LM will be released from the CSM, and the service module reaction control engines activated, to translate the spacecraft away from the LM.

Following this separation, the spacecraft will be operationally maneuvered for the inertial measurement unit alignment. After fine-alignment of the inertial measurement unit, a series of three navigational sightings will be made to establish the transearth injection trajectory, computed by MSFN and subsequently confirmed with the Apollo guidance computer. The final transearth injection operational parameters, service module reaction control system ullage acceleration, required service propulsion system firing time, incremental velocity, thrust vector, and transearth injection attitude are determined and confirmed by MSFN.

#### TRANSEARTH INJECTION AND COAST

The transearth injection phase covers the period of time the service propulsion system burns when injecting the spacecraft into a transearth trajectory.

For each lunar orbit there exists one opportunity for transearth injection. Injection occurs behind the moon, with respect to the earth, nominally one orbit after completion of rendezvous with the LM. The service propulsion system ullage acceleration is manually initiated to begin the earth injection sequence. The injection velocity increment for the predetermined transit time to earth is initiated with the service propulsion system thrust controlled by the guidance and navigation system.

The transearth coast phase begins with service propulsion system engine cutoff following transearth injection and ends at the entry interface altitude of 400,000 feet.

The transearth injection will be operationally performed to place the spacecraft in a return trajectory toward the earth, and will require a minimum of operational maneuvers and corrections. A delta V budget sufficient to provide a total

velocity correction of 300 feet a second during the transearth coast phase is provided. Nominally, three transearth velocity corrections may be made: one near the moon; the second near the midpoint of the return trajectory; and the third delta V increment near the earth.

The primary operations which occur consist of periodic systems checks, trajectory verification, determination of the delta V correction required, preparation for jettison of the service module, service module jettison from the command module, and preparation for earth entry.

The midcourse corrections are determined by means of sequential trajectory verifications. The navigational sightings are made with the scanning telescope and sextant on known landmarks and stars. The Apollo guidance computer computes variations from the required trajectory parameters, determines velocity changes (if necessary), thrust vectors, and firing time, and confirms this data with MSFN. The delta V is operationally implemented and the verification of the velocity correction is subsequently determined after each midcourse correction.

#### SERVICE MODULE JETTISON

Following the last midcourse correction, preparatory activity will be initiated for jettisoning the service module. The near-earth entry corridor and preentry parameters for separation of the service module from the command module will be determined by MSFN and confirmed by the Apollo guidance computer. The final systems check will be performed and the spacecraft oriented for service module jettison. To effect space separation of the command module and service module, the command module entry batteries will be activated, and the service module operationally jettisoned by separation of the adapter and subsequent translational thrust by the service module reaction control engines. The command module is then oriented into a MSFN-confirmed entry attitude by the command module reaction control engines.

A status check will be made of the systems after service module separation, a final operational check will be made of the systems for entry and confirmation of the entry parameters will be made with MSFN. The entry monitor control and display

will be operationally activated, entry alignment of the inertial measurement unit made, and utilization of the flight director attitude indicator and Apollo guidance computer implemented.

## EARTH ENTRY

The earth entry phase begins at an altitude of 400,000 feet and ends with touchdown.

The operational control of the entry is dependent on the range required from the 400,000-foot entry point to the landing area. For short-entry ranges, no skipout maneuver is required. For entry ranges approaching the upper limit, a skipout maneuver is required to attain the greater distance. In either case, the lift maneuver is controlled by rolling the command module using the reaction control engines. Operational control is normally maintained through the guidance and navigation system with the pilot providing a backup capability with the use of the entry monitor display.

Entry into the earth atmosphere is sensed by a 0.05G signal indication. The entry attitude is determined on the flight director attitude indicator, and the entry monitor control display is observed. The Apollo guidance computer computes the range to "go" and provides navigation from the 0.05G point and time.

The range control maneuver is initiated by reaction control engines roll control and necessary pitch and yaw damping. The entry monitor display indicates the delta V and G level, the command module delta V/G level time history, and the survival display requirements. The guidance and navigation system executes the required reaction control system roll commands.

## EARTH LANDING

The earth landing system is operationally armed at an altitude of 100,000 feet. The earth landing system automated sequencer deploys the forward heat shield at 24,000 feet. Two seconds later, the two drogue chutes are mortar-deployed in a reefed condition. The reefing lines are severed and the drogue chutes open fully in

approximately 8 seconds to orient the C/M apex upward during descent to 11,500 feet. Three pilot chutes are automatically connected. The pilot chutes in turn, deploy the three main chutes to a line-stretch, reefed condition. The reefing lines are severed and the main chutes open fully in approximately 8 seconds. The main chutes lower the command module to touchdown and impact at a terminal descent velocity assuring a nominal impact G level consistent with the safety of the crew. The main chute attach lines are severed upon touchdown.

During the final part of the main chute descent, the recovery communication systems are activated and transmit a location signal for reception by the operational recovery forces.

## RECOVERY OPERATIONS

The recovery operations phase begins with touchdown and ends with the recovery of the crew and retrieval of the command module. The VHF communication system is deployed and begins transmitting a repeating location signal for reception by the recovery task forces deployed in the area of predicted touchdown. Voice communications capability is also provided by an HF communications systems.

If touchdown occurs in water (primary landing), fluorescent dye goes into solution, coloring the water a bright, fluorescent, yellow-green over an extended area. The dye should be visible to recover force aircraft or ships for a considerable distance. A flashing beacon light is also provided for use at night.

Immediately following a water (primary) landing, after the main chutes are pyrotechnically cut from the command module, the crew will assist the flotation status and capability of the command module. If the command module enters the water in an inverted stable flotation attitude, the crew will activate the uprighting subsystem after which a decision will be made relative to remaining in the command module or leaving in the inflatable life raft provided for the three crew members. Steps will be taken, as necessary, to effectively secure the command module for optimum flotation stability and subsequent retrieval. The capability is to be provided for helicopter pickup of the command module, with the three crew members inside, using the recovery pickup loop. A nearby ship may pick up the command



module. Land ground forces may pick up the command module if the land touchdown point is in an accessible area.

The flotation design will provide a survivable flotation capability for a minimum of 48 hours, under design sea conditions. A water landing provides fewer touchdown hazards and a correspondingly greater safety for the crew. Natural ground terrain, in most of the possible touchdown land areas evaluated, would cause an excessive impact shock for the crew.

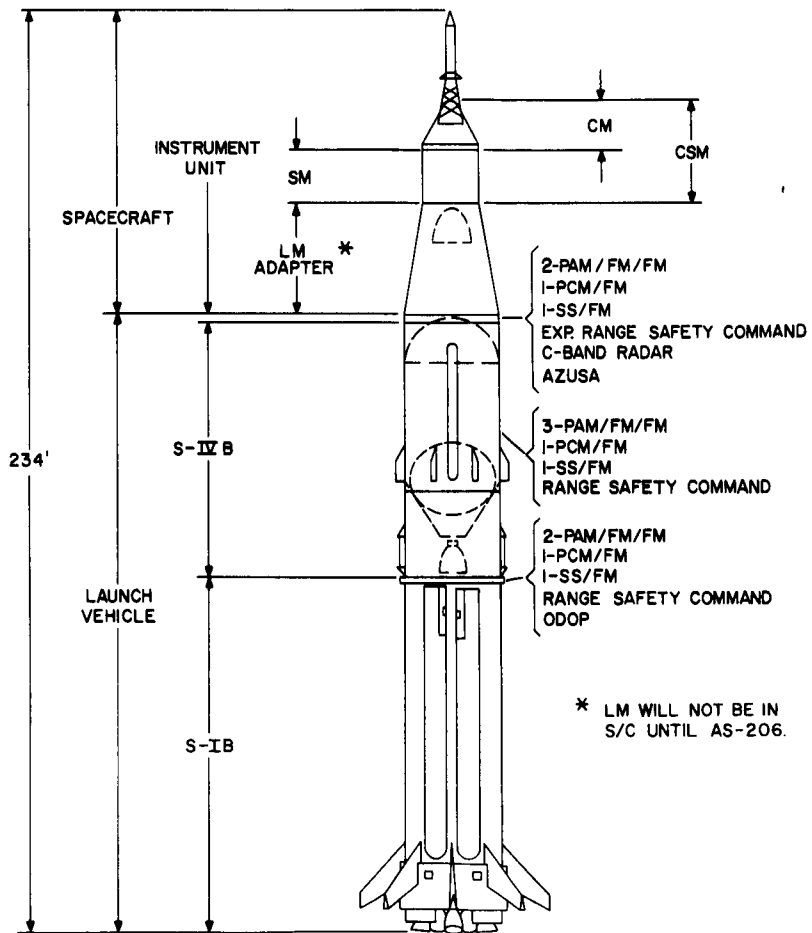

559003

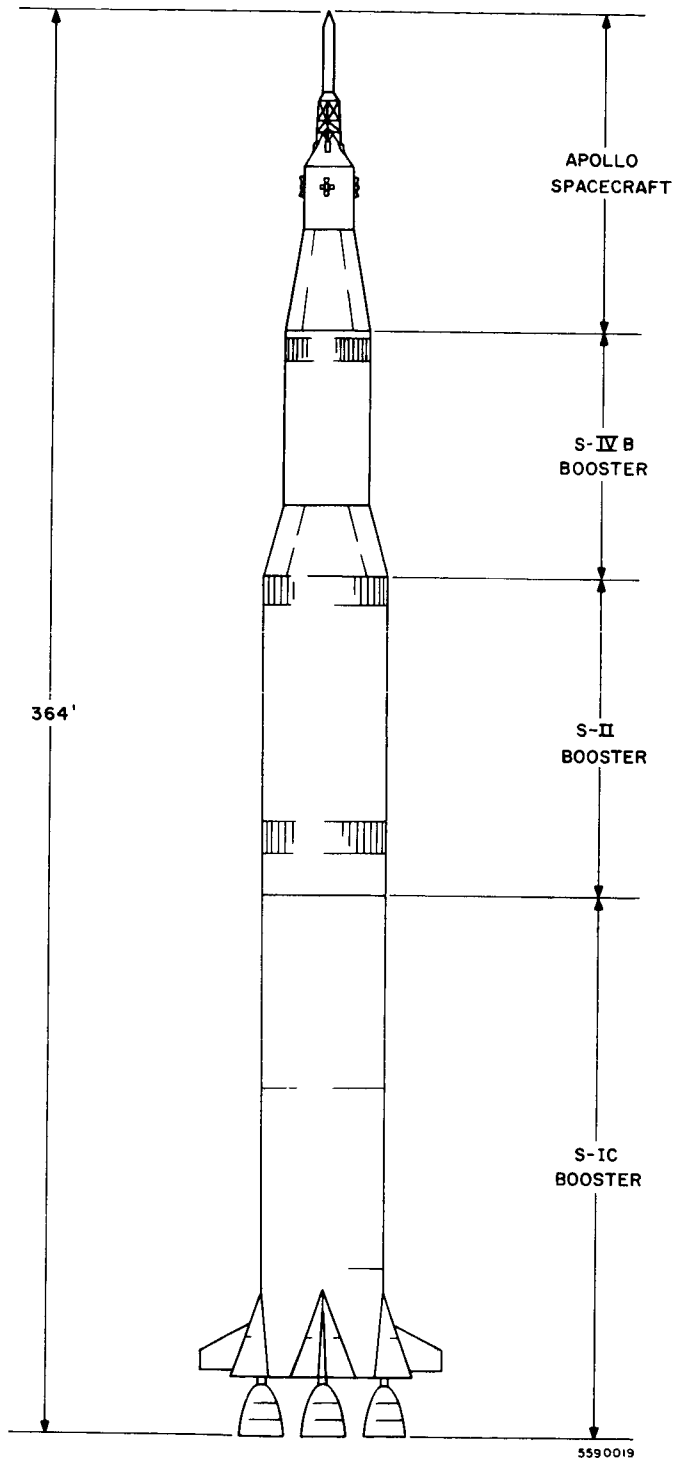

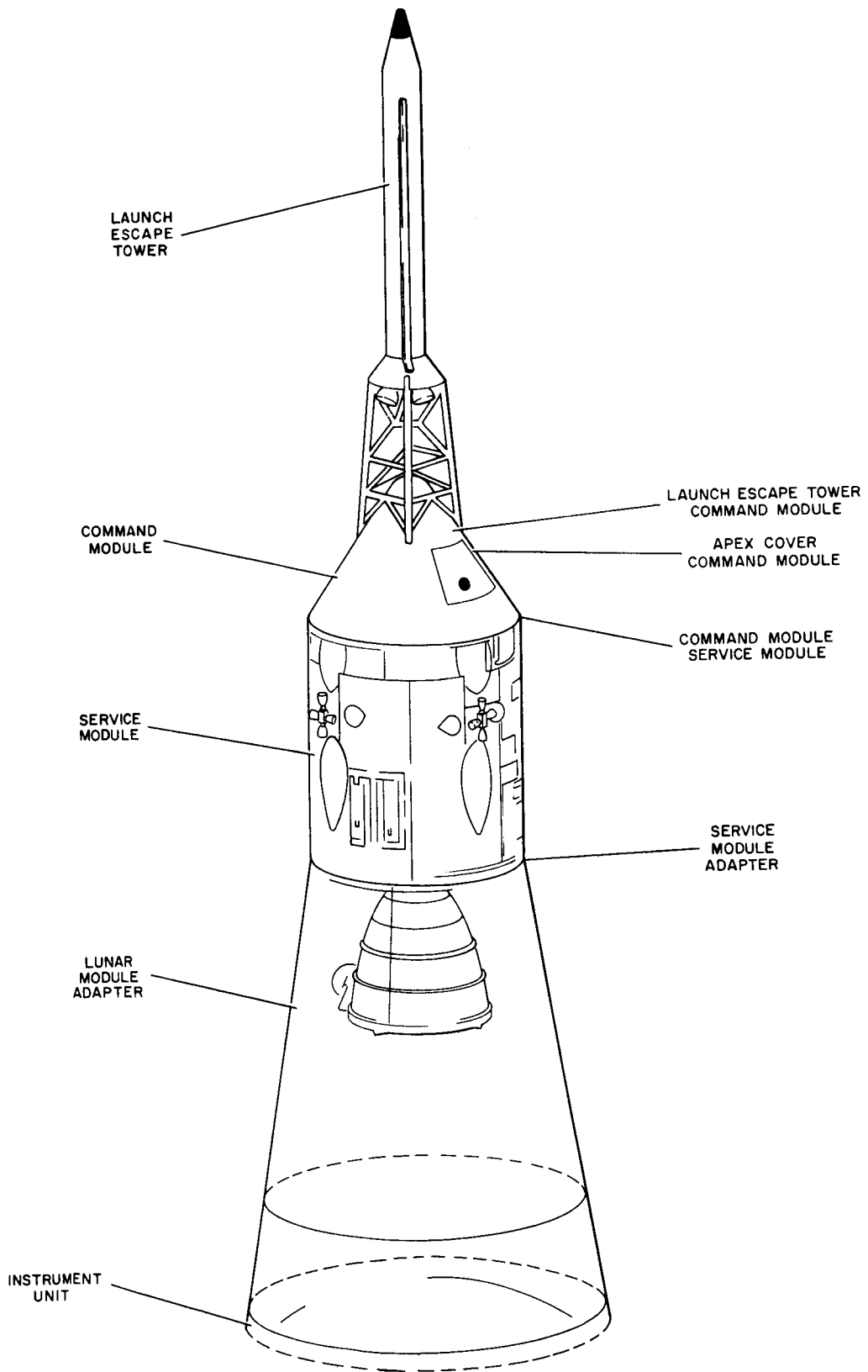

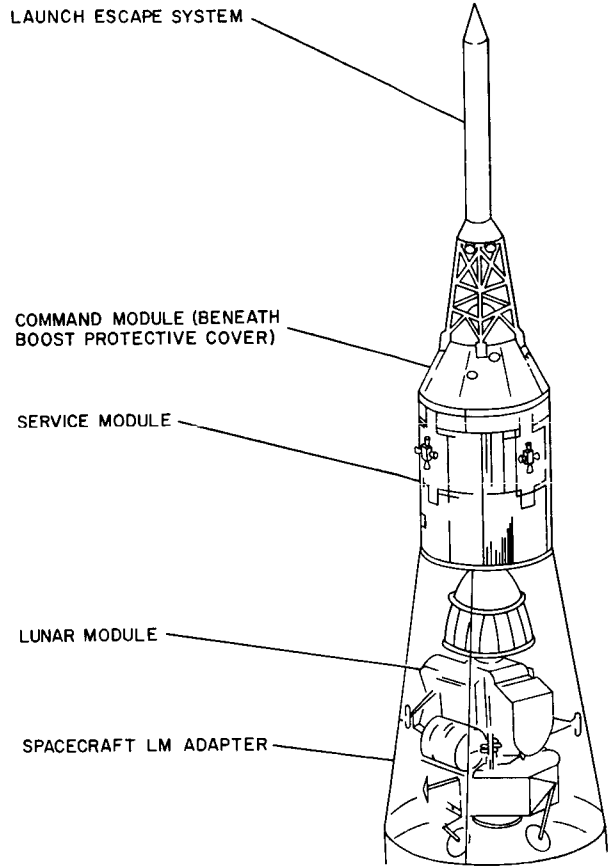

5590020

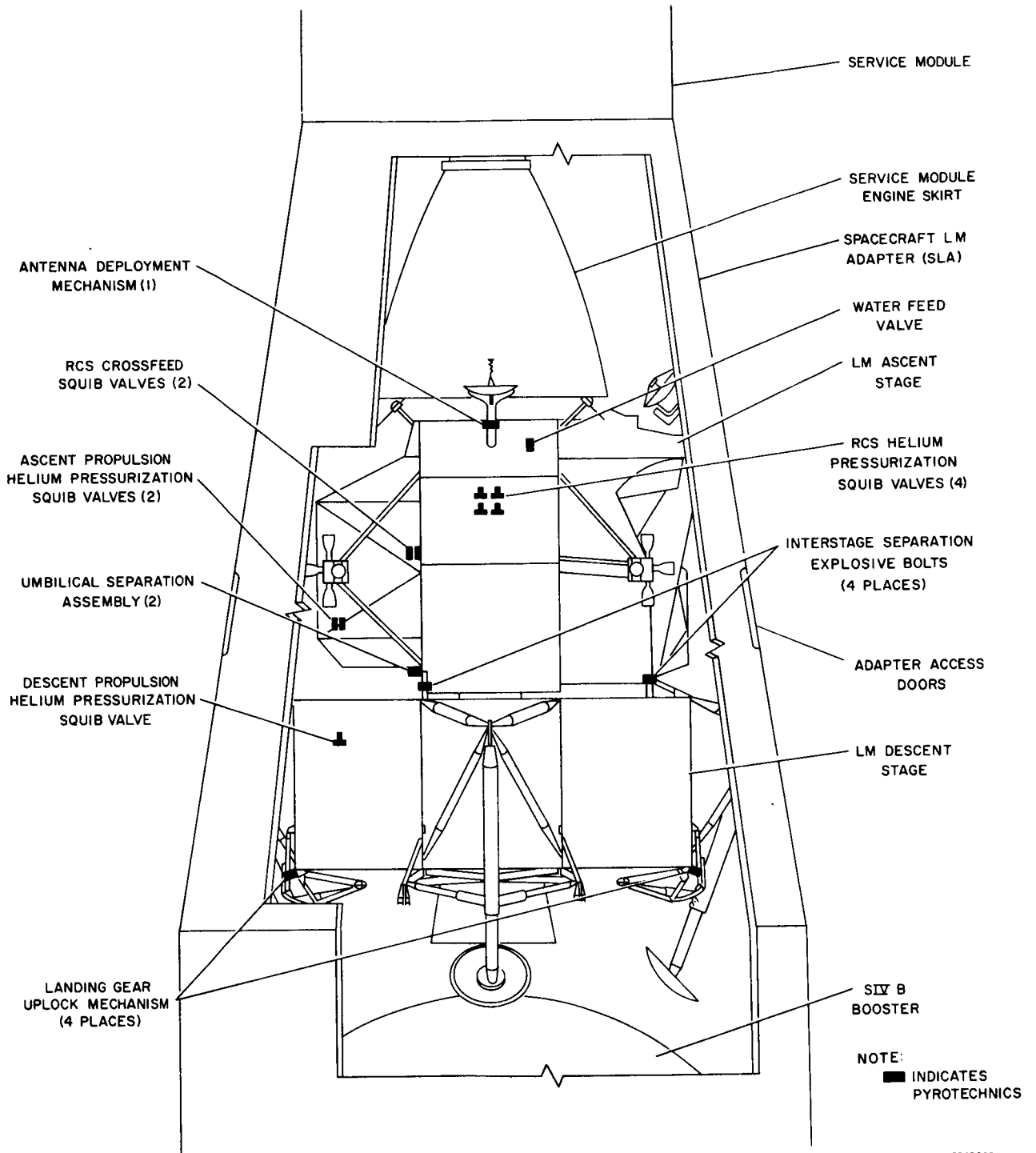

5543003

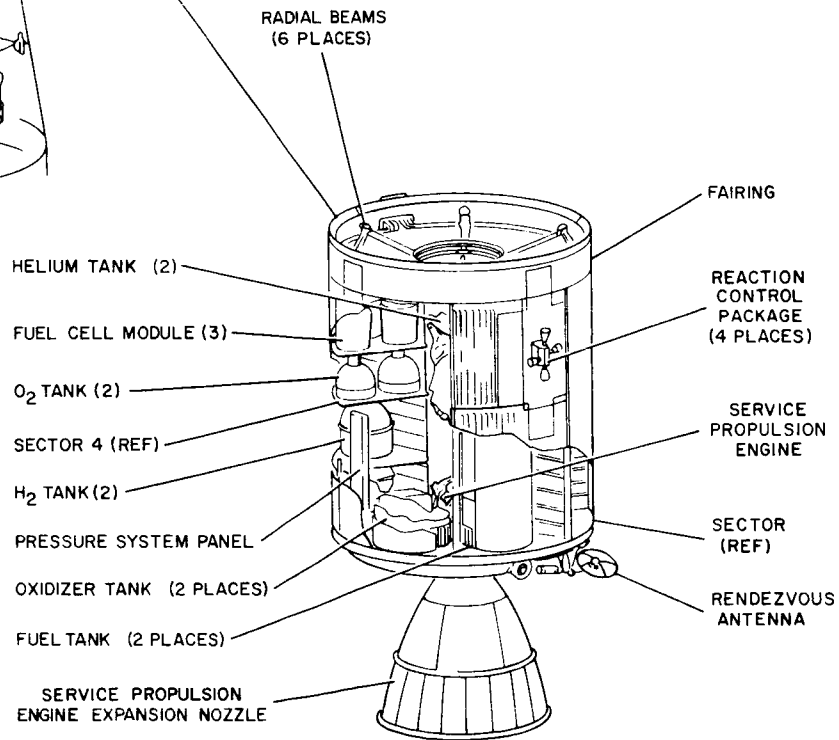
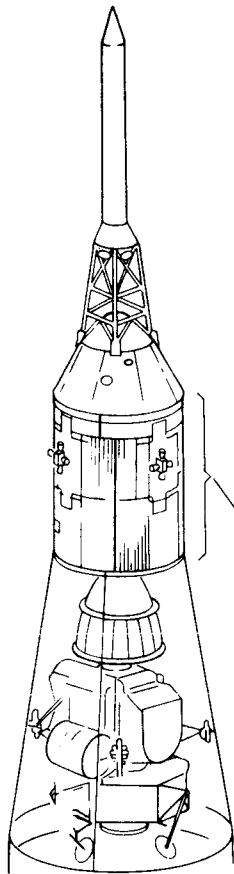

5590015

1-30

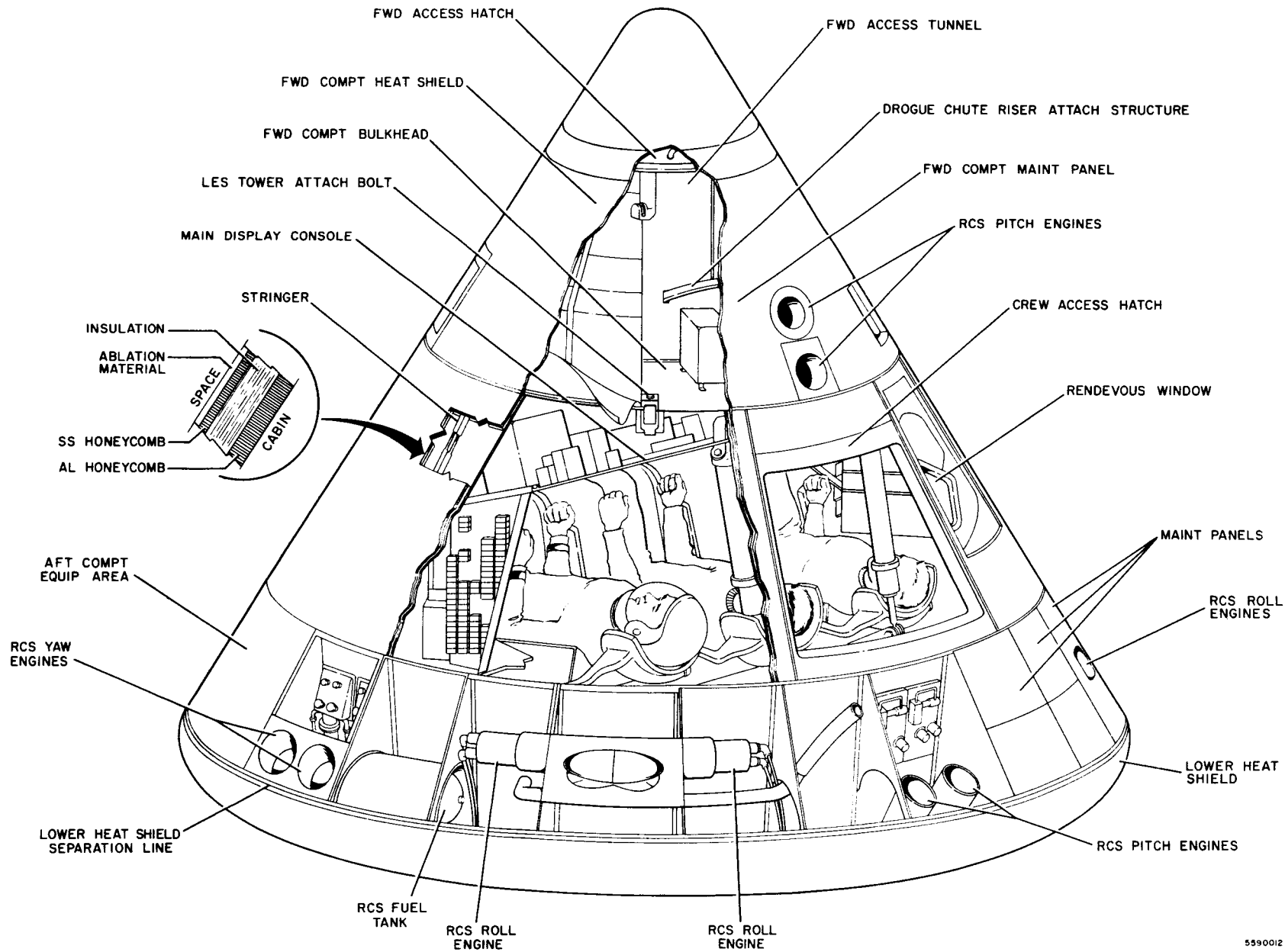

5590012

TRAINING USE ONLY

GENERAL ARRANGEMENT COMMAND MODULE AI-022



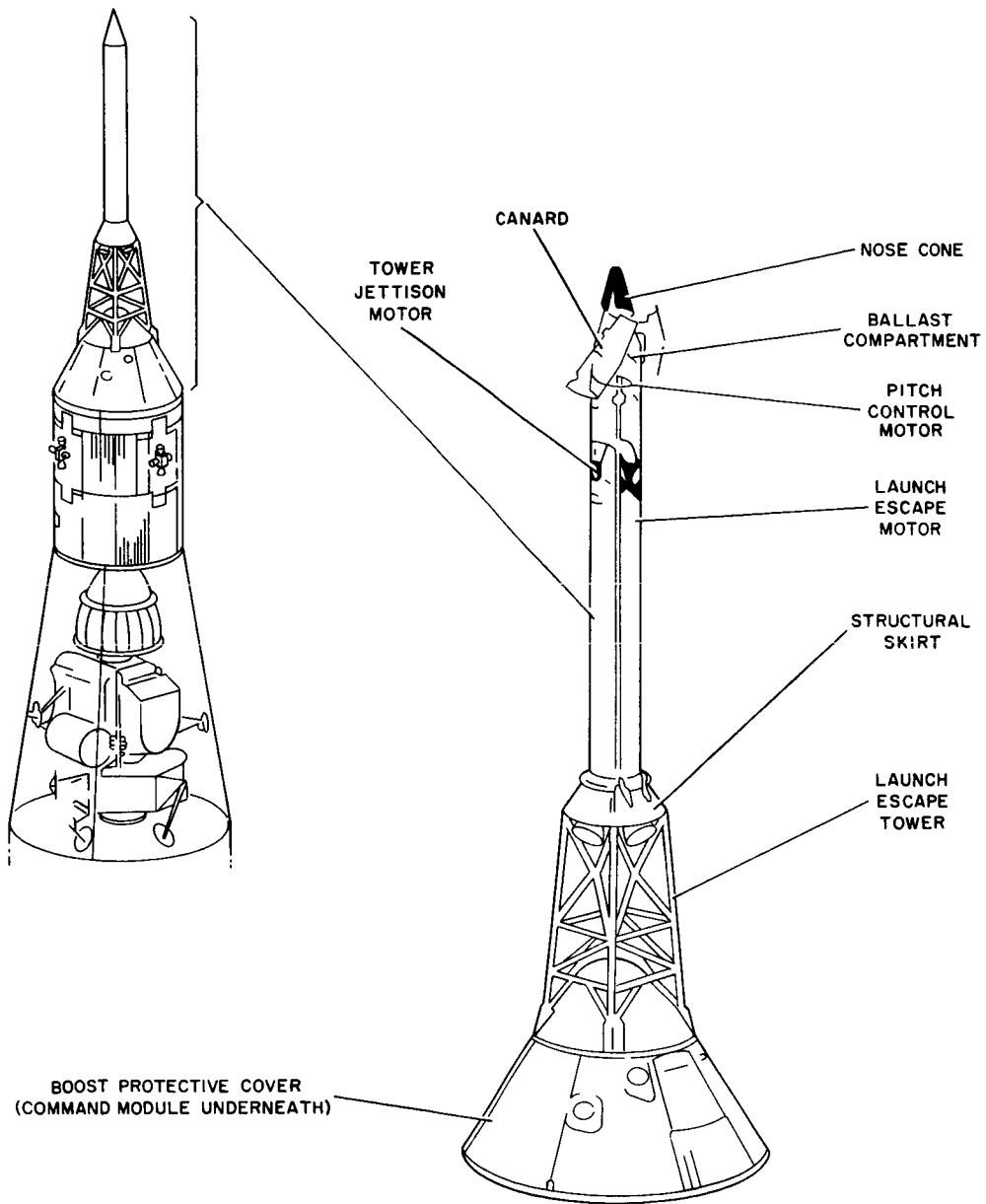

5590016A

SAME AS FOR NORMAL  
C/M-S/M SEPARATION  
WITH THE FOLLOWING ADDED:

1. FIRES L/E & P/C MOTORS OF LES
2. DEPLOYS CANARDS OF LES
3. COMMANDS BECO (IF T 40 SEC)
4. ENABLES AUTO C/M RCS CONTROL (IF T 42 SEC)
5. ENABLES AUTO C/M RCS OXIDIZER DUMP (IF T 42 SEC)
6. ENABLES ELSC LOGIC ARMING
7. PERFORMS LET & APEX COVER JETTISON

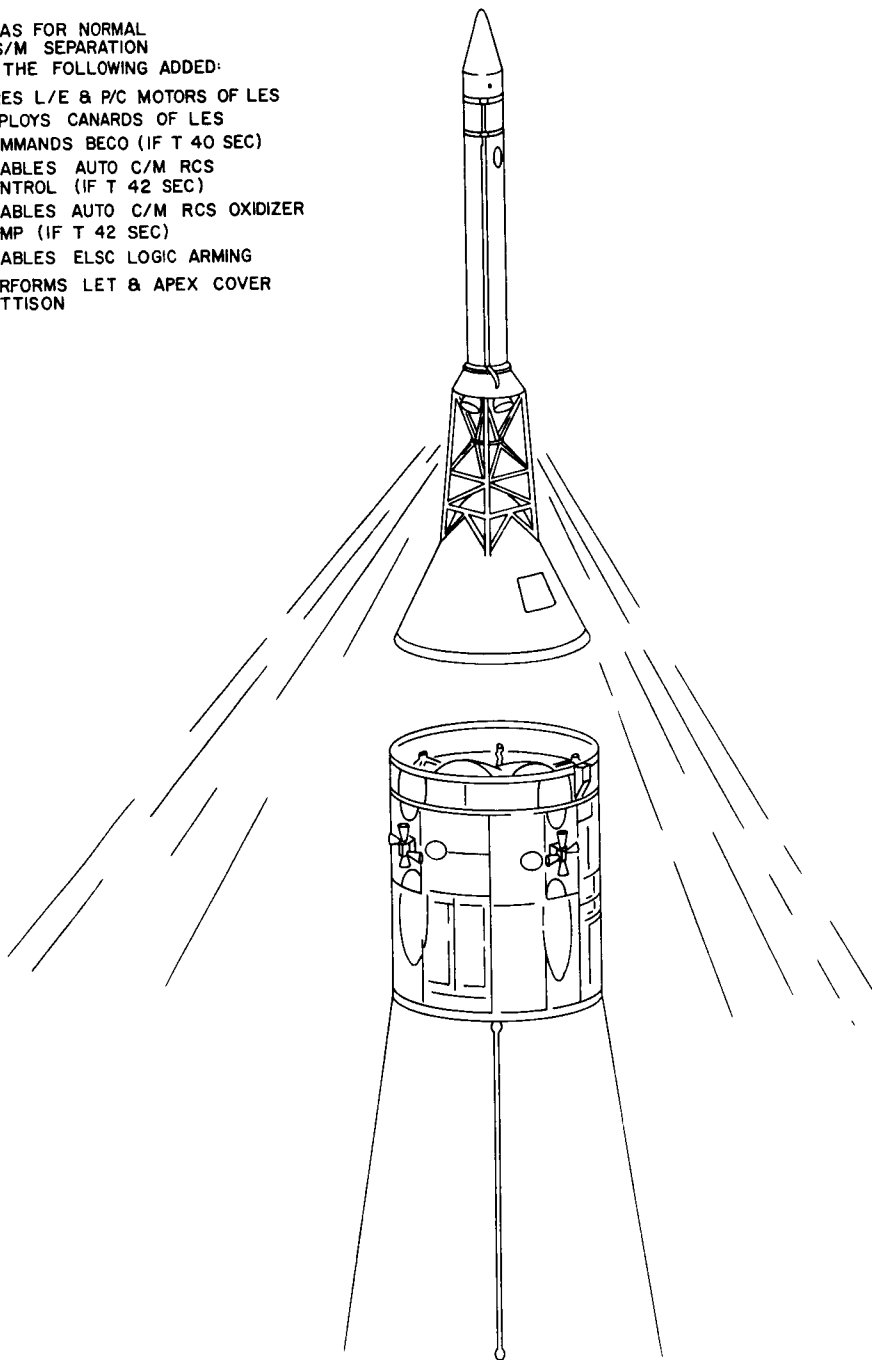

5543006

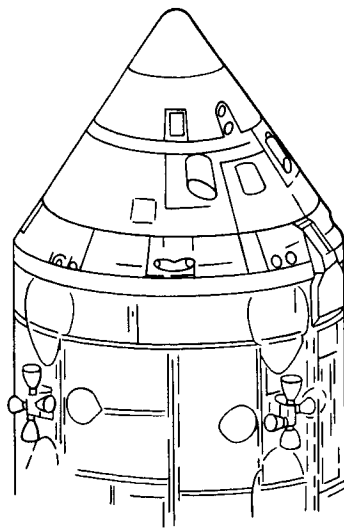
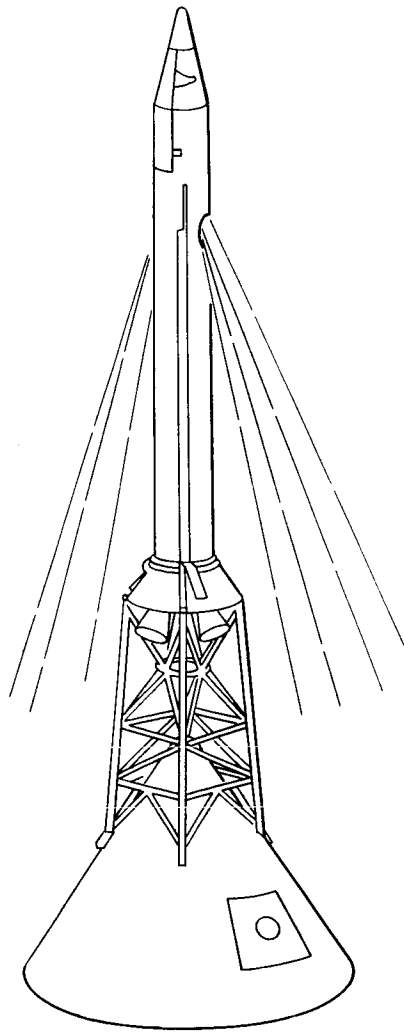

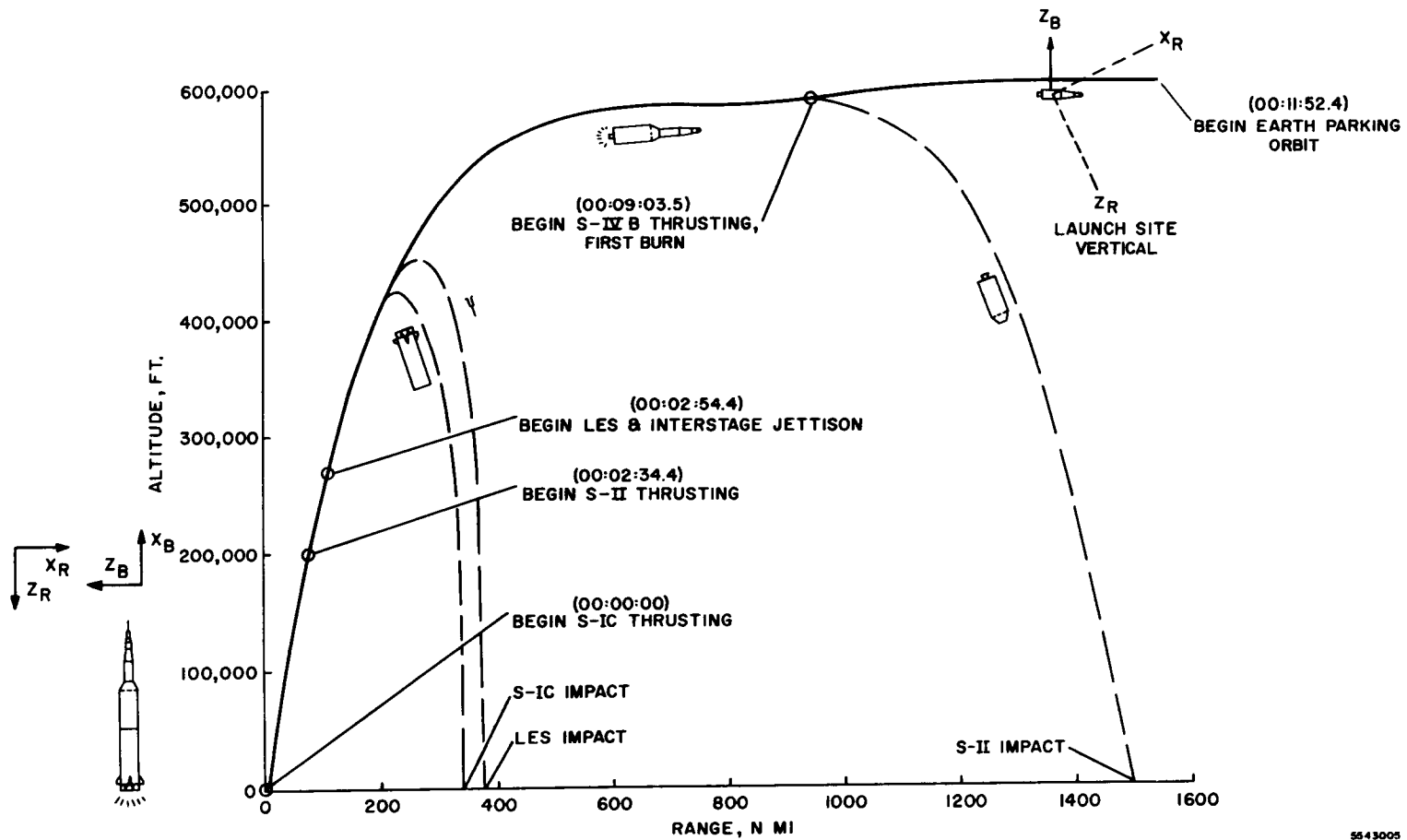

5543005

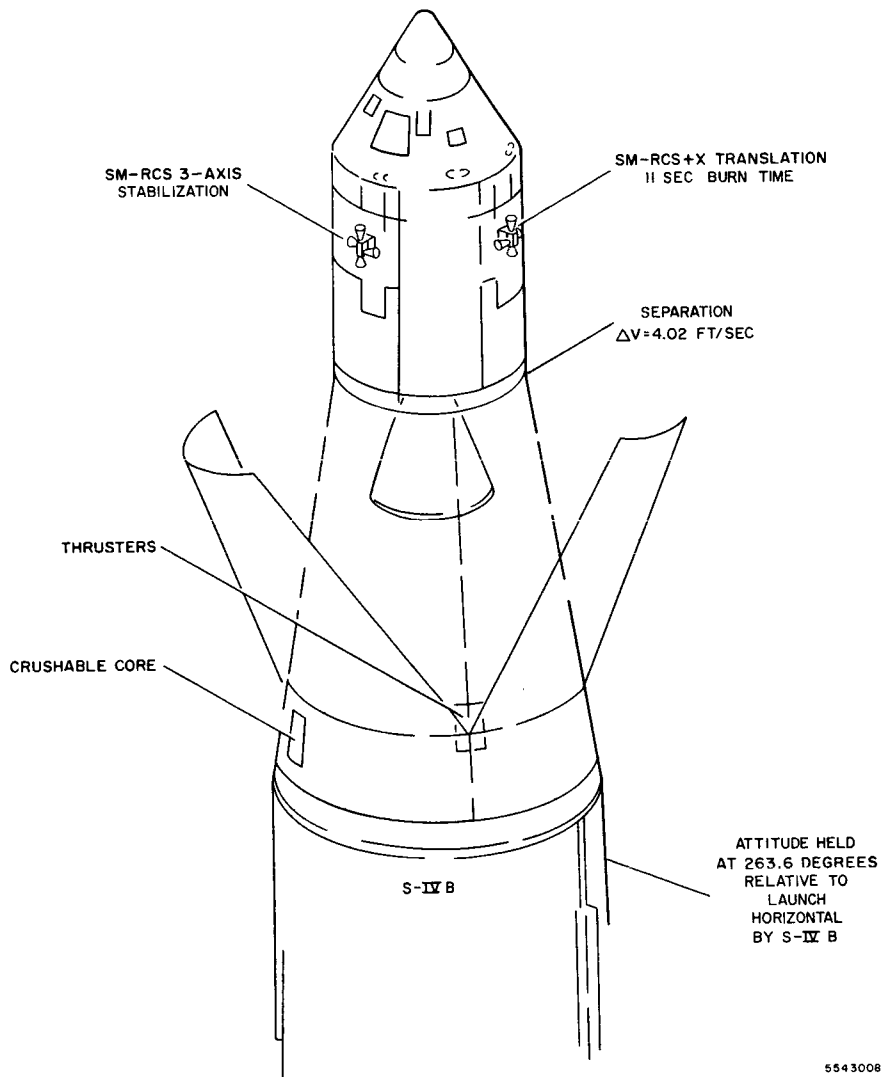

554 3008

NOMINAL ELAPSED TIME SEQUENCE

AFTER LIFT-OFF	EVENT
2.8 Hours	Lunar Injection
3.3-3.5 Hours	Transposition (Turn Around) Discard Third Stage
72.8 Hours	Arrive at Moon (3 Days)
74.5 Hours	Lunar Touchdown for 24-Hour Stay on Moon
98.5 Hours	Lunar Lift-off after 24-Hour Stay on Moon
99.9 Hours	Rendezvous at Moon
103.5 Hours	Leave Lunar Orbit for Earth
196 Hours	Start Reentry
196.6 Hours	Earth Touchdown (8 Days)

6585007

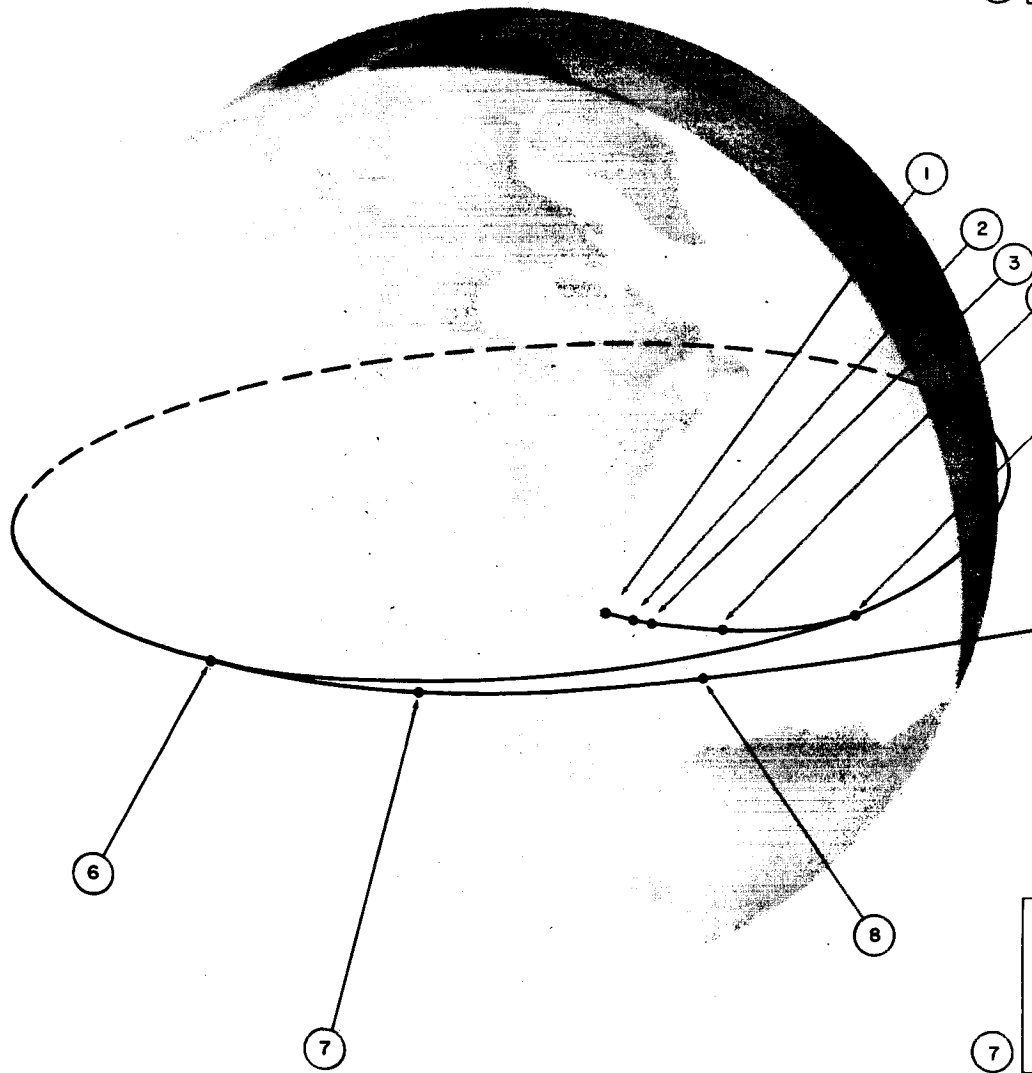

1

1

2

3

7

BEG  
TO

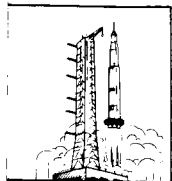

2.1 (00:00:00)  
LIFTOFF

2

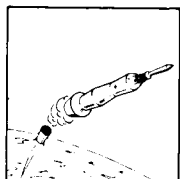

2.2.1 (00:02:34)  
BEGIN S-II  
THRUSTING

3

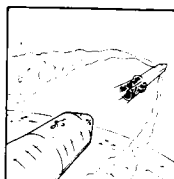

2.2.2 (00:02:54)  
JETTISON LES  
AND INTERSTAGE

4

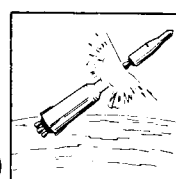

2.3 (00:09:04)  
BEGIN S-IVB  
THRUSTING

5

4

5

9

10

11

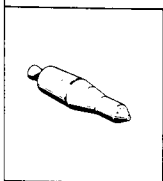

5.1 (03:05:58)  
IN INITIAL COAST  
TRANSPOSITION  
AND DOCKING

8

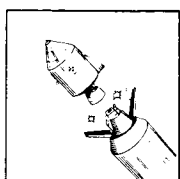

5.2 (03:20:58)  
BEGIN TRANSPOSITION  
AND DOCKING

9

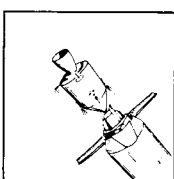

5.3 (03:47:58)  
CSM DOCKED—  
BEGIN COAST THRU  
S-IVB JETTISON

10

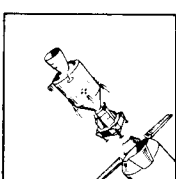

6.1 (03:50:58)  
JETTISON S-IVB  
BEGIN COAST TO  
LUNAR ORBIT INSERTION

11



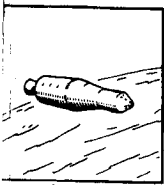

3.1 (00:11:52)  
EARTH ORBIT  
INSERTION

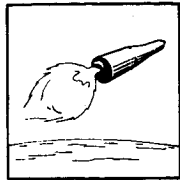

6  
4.0 (03:00:43)  
BEGIN TRANSLUNAR  
INJECTION ON  
SECOND ORBIT

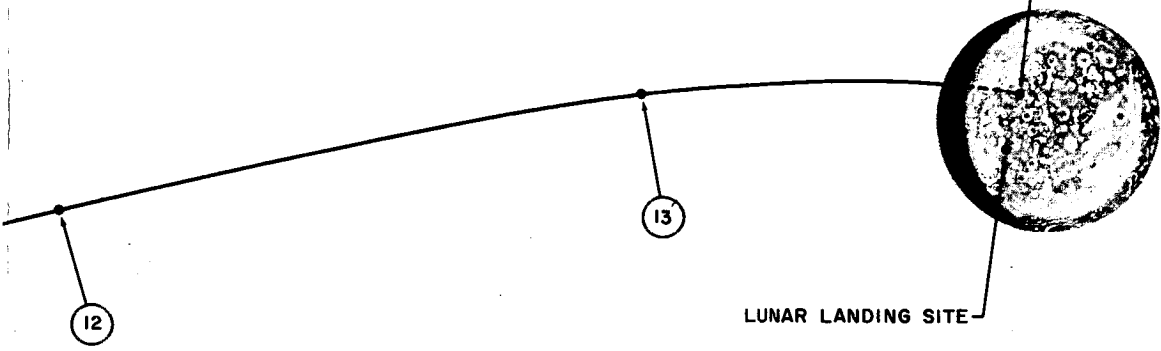

5.1.2 (05:05:58)  
FIRST MIDCOURSE  
CORRECTION



12  
6.2.2 (55:30:00)  
SECOND MIDCOURSE  
CORRECTION



13  
6.3.2 (63:15:04)  
THIRD MIDCOURSE  
CORRECTION

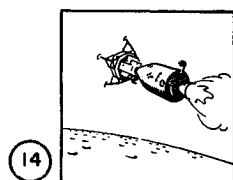

14  
7.0 (64:15:04)  
BEGIN LUNAR  
ORBIT INSERTION

5543009

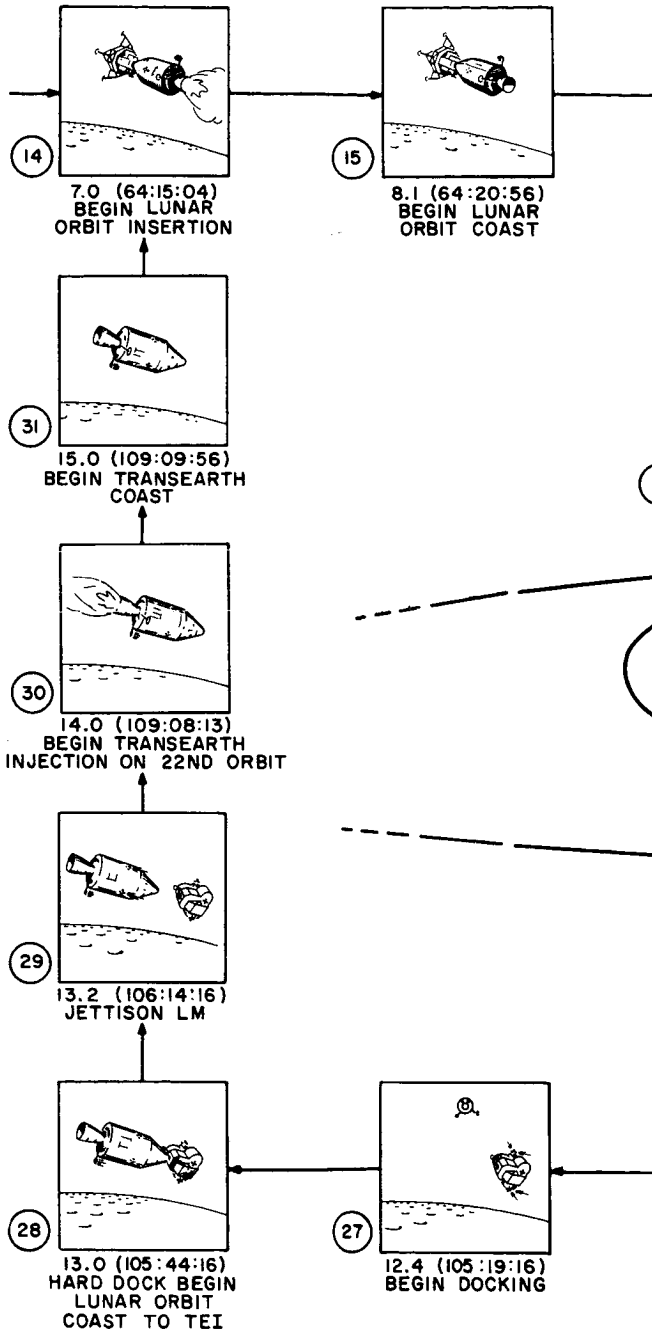

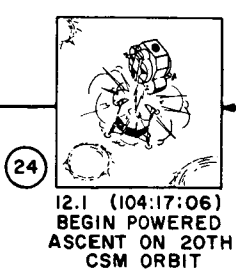
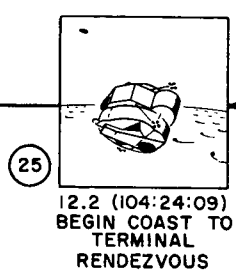
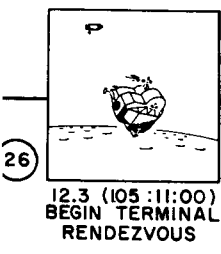
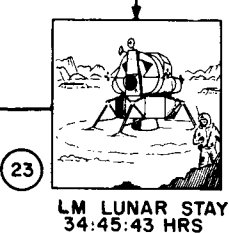
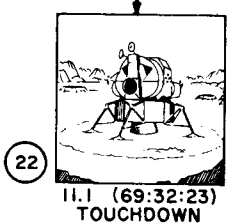
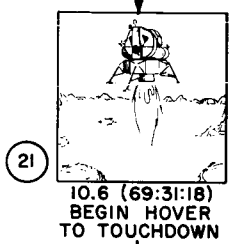
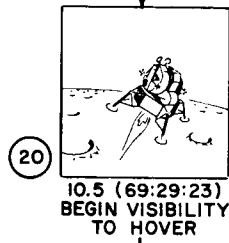
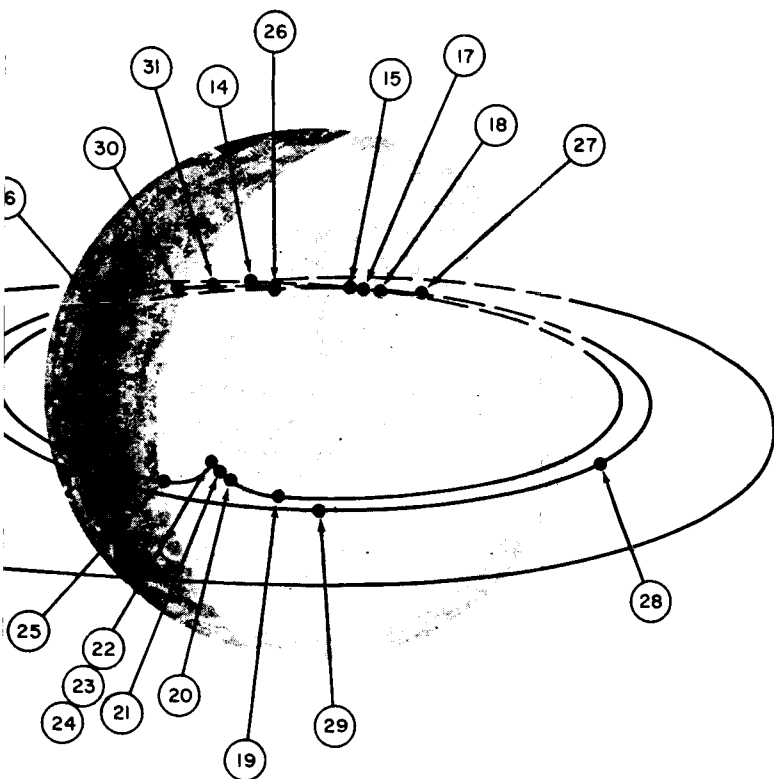
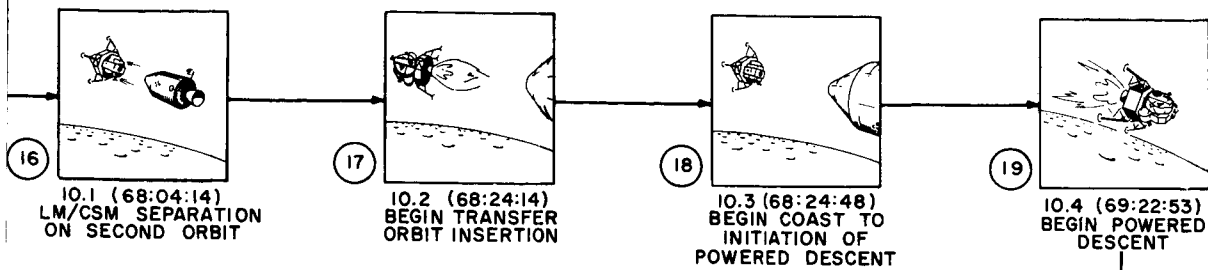

5543010

TRAINING USE ONLY

LUNAR  
VICINITY MISSION  
DESCRIPTION AI-009

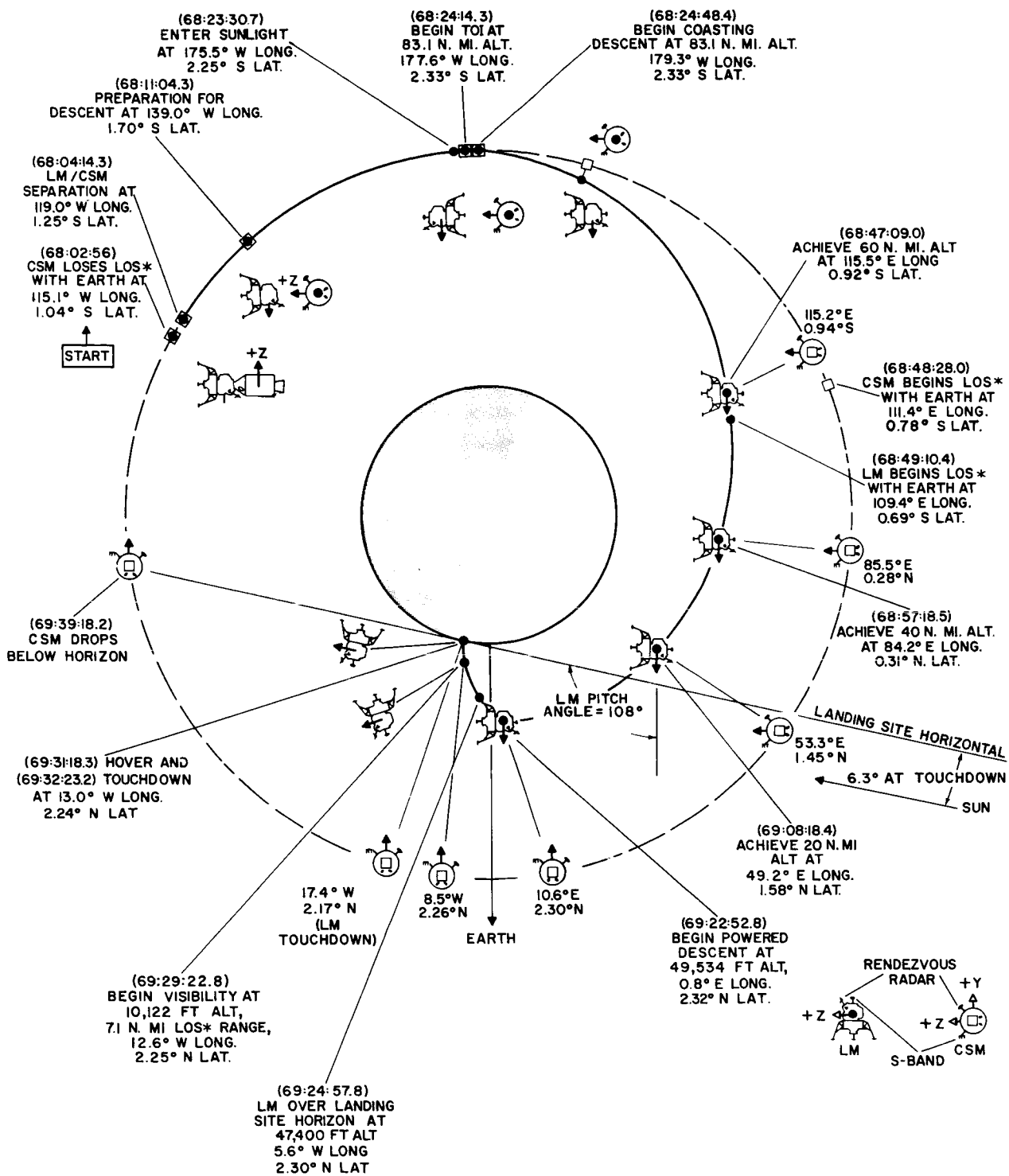

NOTE:  
\*LOS INDICATES LINE OF SIGHT

5543011

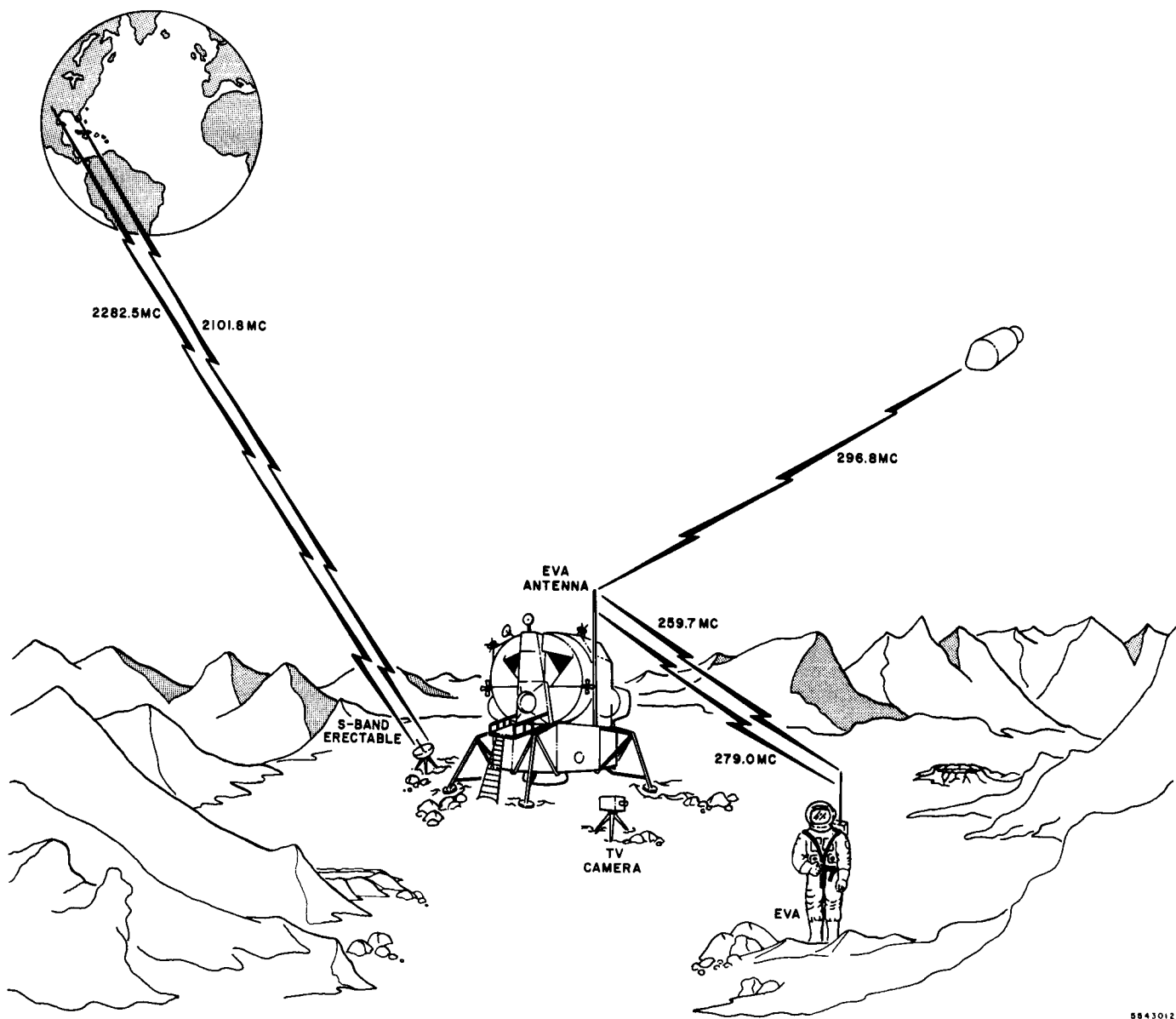

5843012

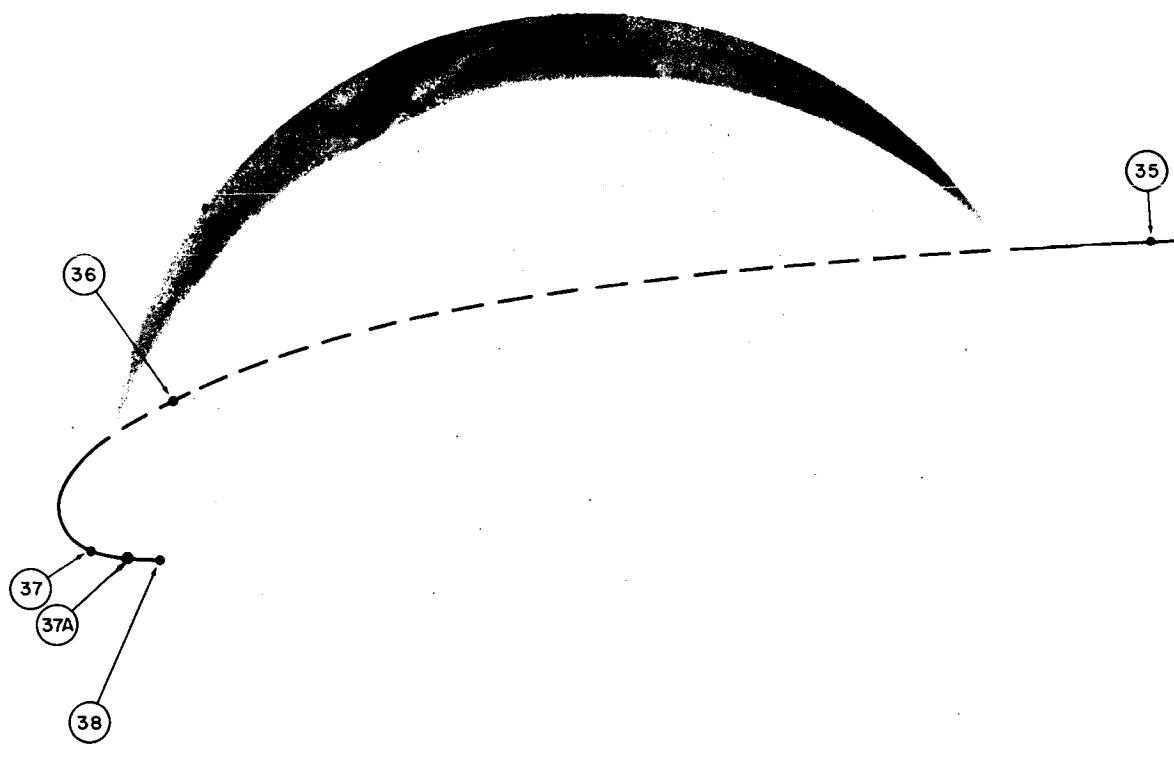

35

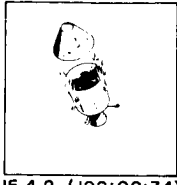

15.4.2 (198:00:34)  
JETTISON SM

34

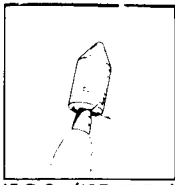

15.3.2 (197:15:34)  
THIRD MIDCOURSE  
CORRECTION

33



15.2.2 (174:09:56)  
SECOND MIDCOURSE  
CORRECTION

34

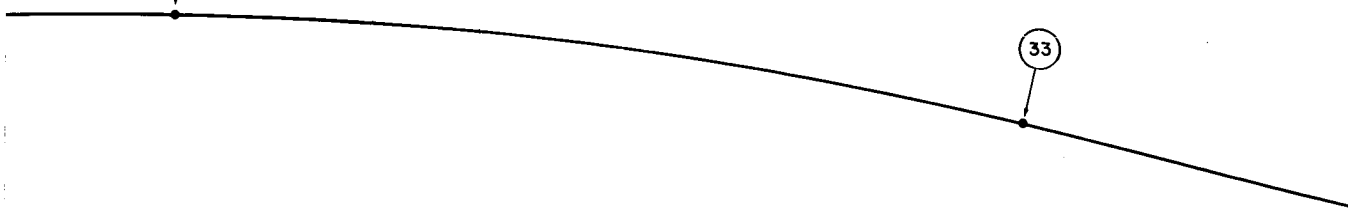

33



36

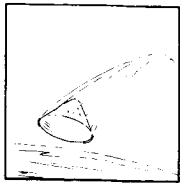

16.0 (198:15:34)  
ENTRY

37

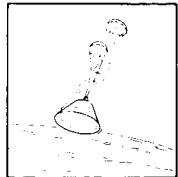

17.0 (198:26:01)  
BEGIN PARACHUTE  
DESCENT

37A



(198:26:59)  
JETTISON DROGUE  
CHUTE MAIN CHUTE  
DEPLOYMENT

38



18.0 (198:27:00)  
EARTH

32

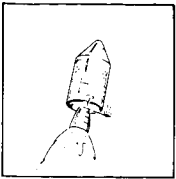

15.1.2 (129:09:56)  
FIRST MIDCOURSE  
CORRECTION

31

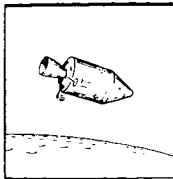

15.0 (109:09:56)  
BEGIN TRANSEARTH  
COAST

31

32

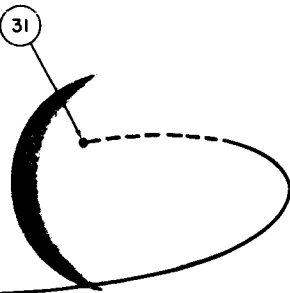

8:33:08)  
LANDING



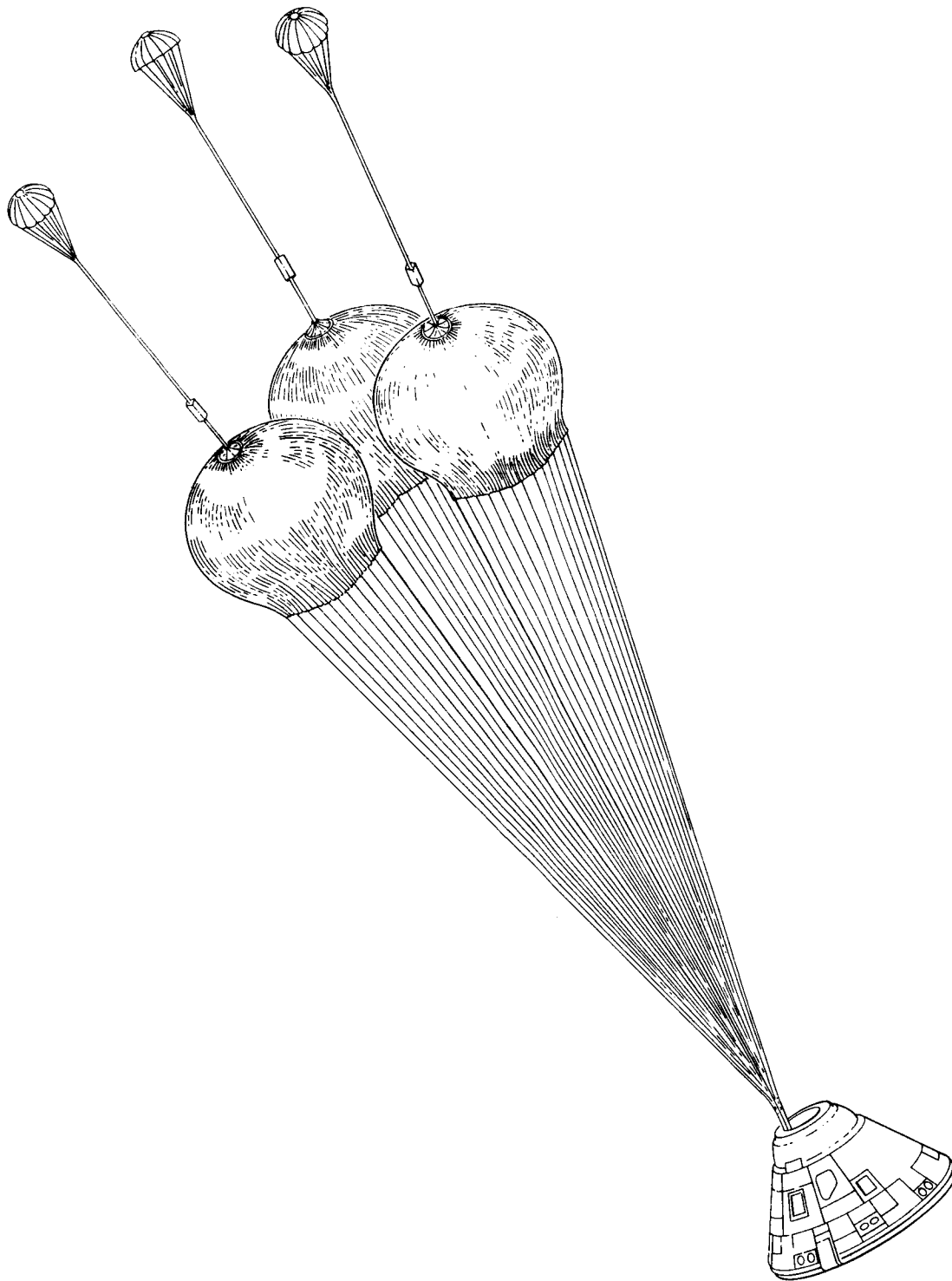

5543016

1-46

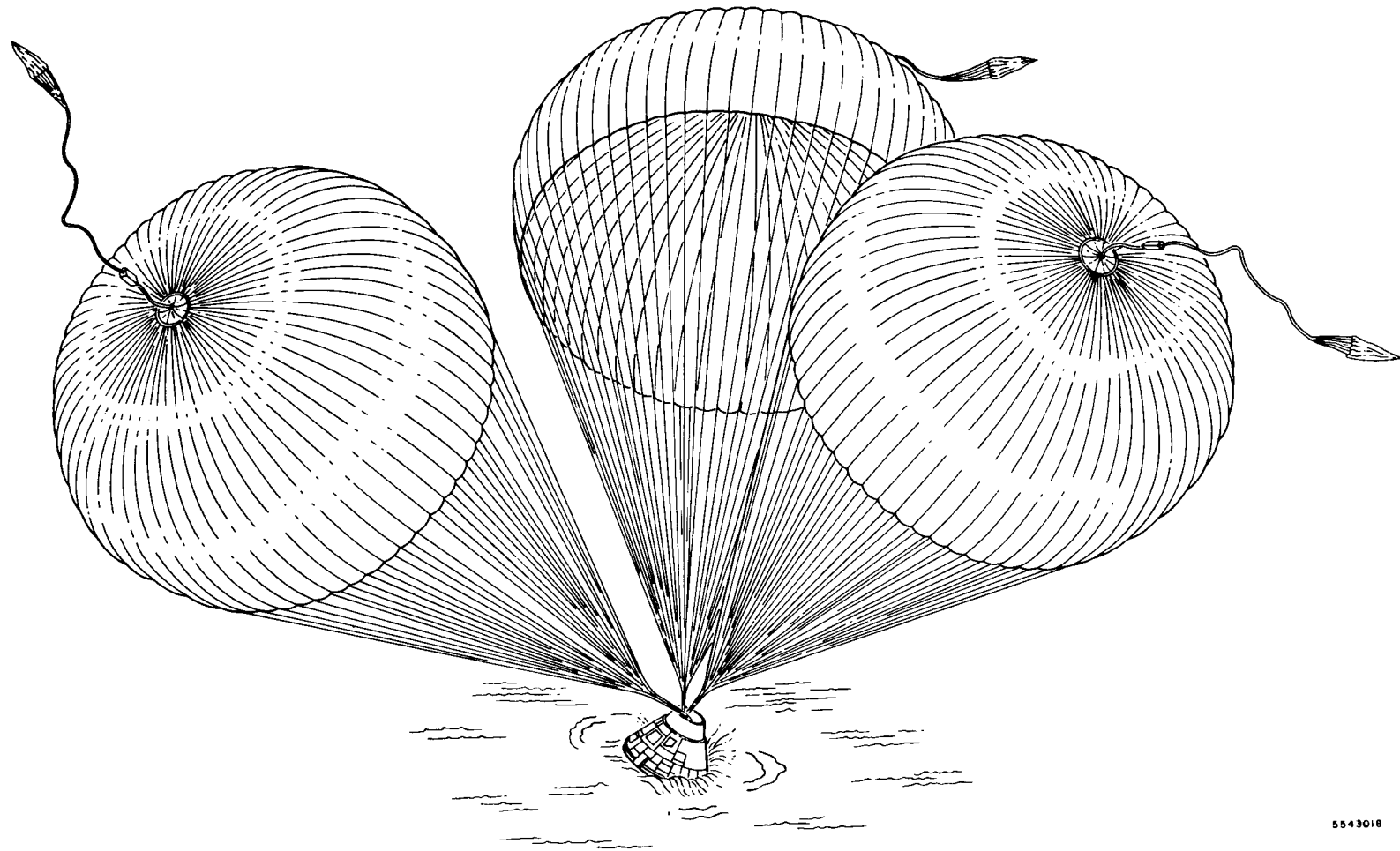

5543018

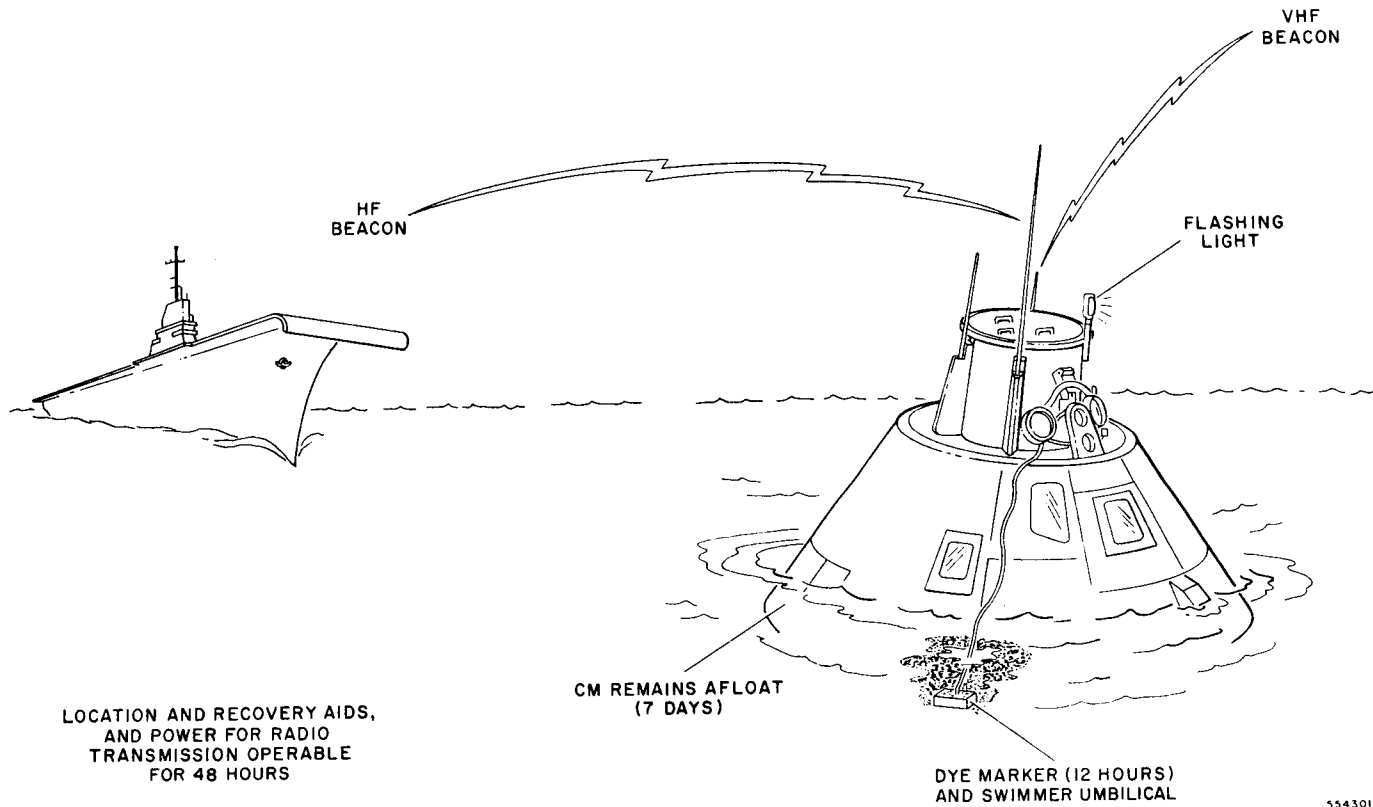

5543019

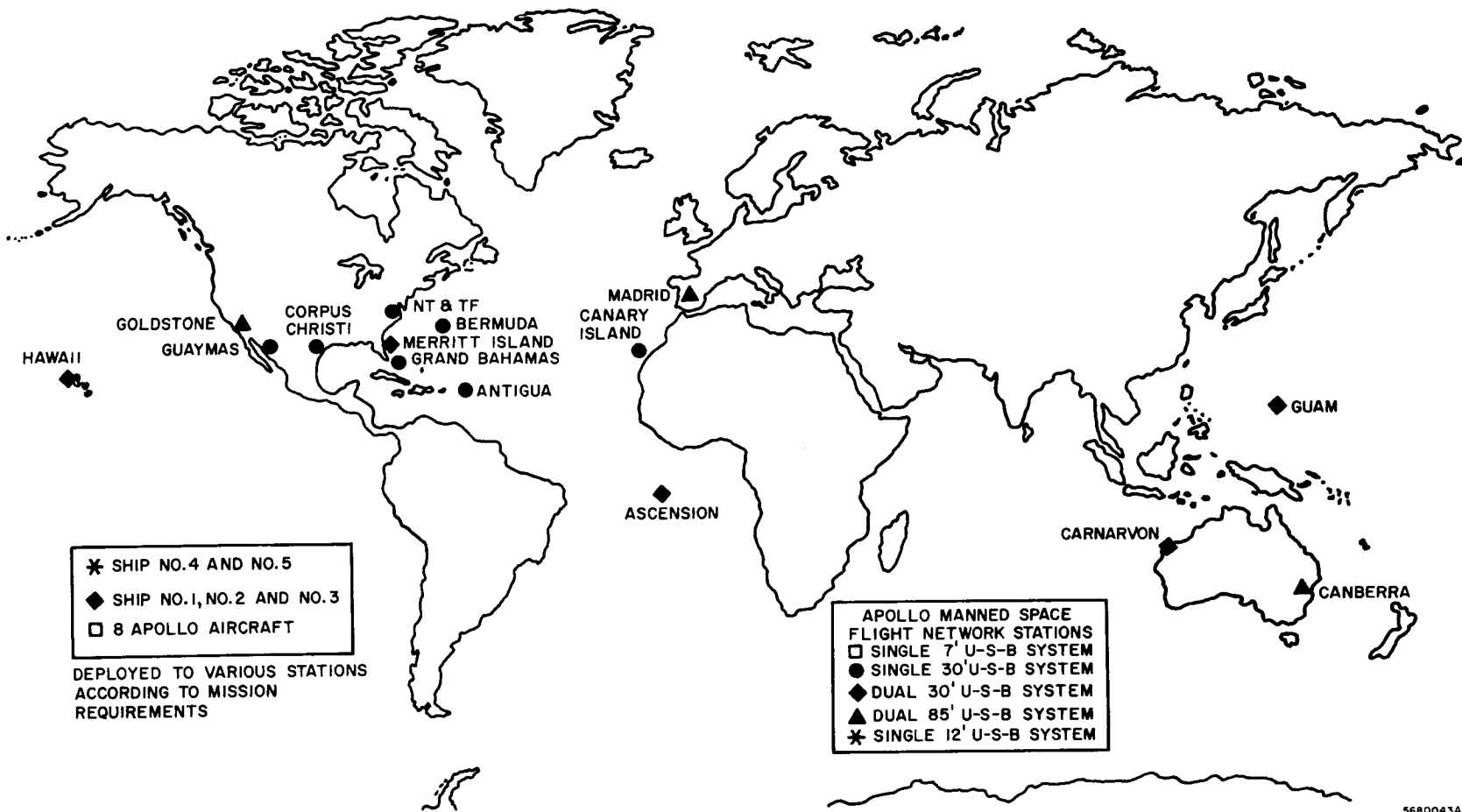

\* SHIP NO. 4 AND NO. 5  
 ◆ SHIP NO. 1, NO. 2 AND NO. 3  
 □ 8 APOLLO AIRCRAFT

DEPLOYED TO VARIOUS STATIONS  
 ACCORDING TO MISSION  
 REQUIREMENTS

APOLLO MANNED SPACE  
 FLIGHT NETWORK STATIONS  
 □ SINGLE 7' U-S-B SYSTEM  
 ● SINGLE 30' U-S-B SYSTEM  
 ◆ DUAL 30' U-S-B SYSTEM  
 ▲ DUAL 85' U-S-B SYSTEM  
 \* SINGLE 12' U-S-B SYSTEM

5680043A

UNIFIED S-BAND STATIONS

SITE	ANT. SIZE	LAUNCH	INSERTION	NEAR EARTH	INJECTION	LUNAR	RE-ENTRY
* CARNARVON	30'			X	X		
BERMUDA	30'	X	X	X			
TEXAS	30'			X			
* MERRITT ISLAND	30'	X	X	X	X		
GUAYMAS	30'			X	X		
* HAWAII	30'			X	X		
* GUAM	30'			X	X		
* ASCENSION	30'			X	X		
CANARY ISLANDS	30'			X	X		
ANTIGUA	30'		X	X			
GRAND BAHAMA IS.	30'	X	X	X			
Δ GOLDSTONE	85'					X	
Δ CANBERRA	85'					X	
Δ MADRID	85'					X	
* SHIP NO. 1	30'		X		X		
* SHIP NO. 2	30'				X		
* SHIP NO. 3	30'				X		
SHIP NO. 4	12'						X
SHIP NO. 5	12'						X
AIRCRAFT (8)	7'				X		X

\* DUAL USB SYSTEM  
 Δ DUAL USB STATION

5590001A

I-49

STATION	MERCURY	GEMINI	APOLLO
BERMUDA	X	X	X
CANARY ISLAND	X	X	X
KANO	X	L	(DELETED)
ZANZIBAR	X	(DELETED)	
TANANARIVE		L	L
GUAYMAS	X	X	X
MERRITT IS. (MILA)			X
GUAM			X
GOLDSTONE			X
GOLDSTONE (JPL)			X
MADRID			X
MADRID (JPL)			X
CANBERRA			X
CANBERRA (JPL)			X
MUCHEA	X	(DELETED)	
WOOMERA	X	R	R
CARNARVON		X	X
HOUSTON (MSC)		X	X
SAN SAL	X	R	
GRAND BAHAMA IS.	X	X	X
GRAND TURK IS.	X	X	L
ANTIGUA IS.	X	X	X
ASCENSION			X
CANTON	X	L	L
HAWAII	X	X	X
POINT ARGUELLO	X	R	R
WHITE SANDS	R	R	R
CORPUS CHRISTI	X	X	X
EGLIN	R	R	R
ROSE KNOT	X	X	L
COASTAL SENTRY	X	X	L
APOLLO SHIP 1			X
APOLLO SHIP 2			X
APOLLO SHIP 3			X
APOLLO SHIP 4			X
APOLLO SHIP 5			X
APOLLO AIRCRAFT (8)			X

5680044A

LEGEND: X = FULL SUPPORT  
L = LIMITED SUPPORT  
R = RADAR SUPPORT ONLY

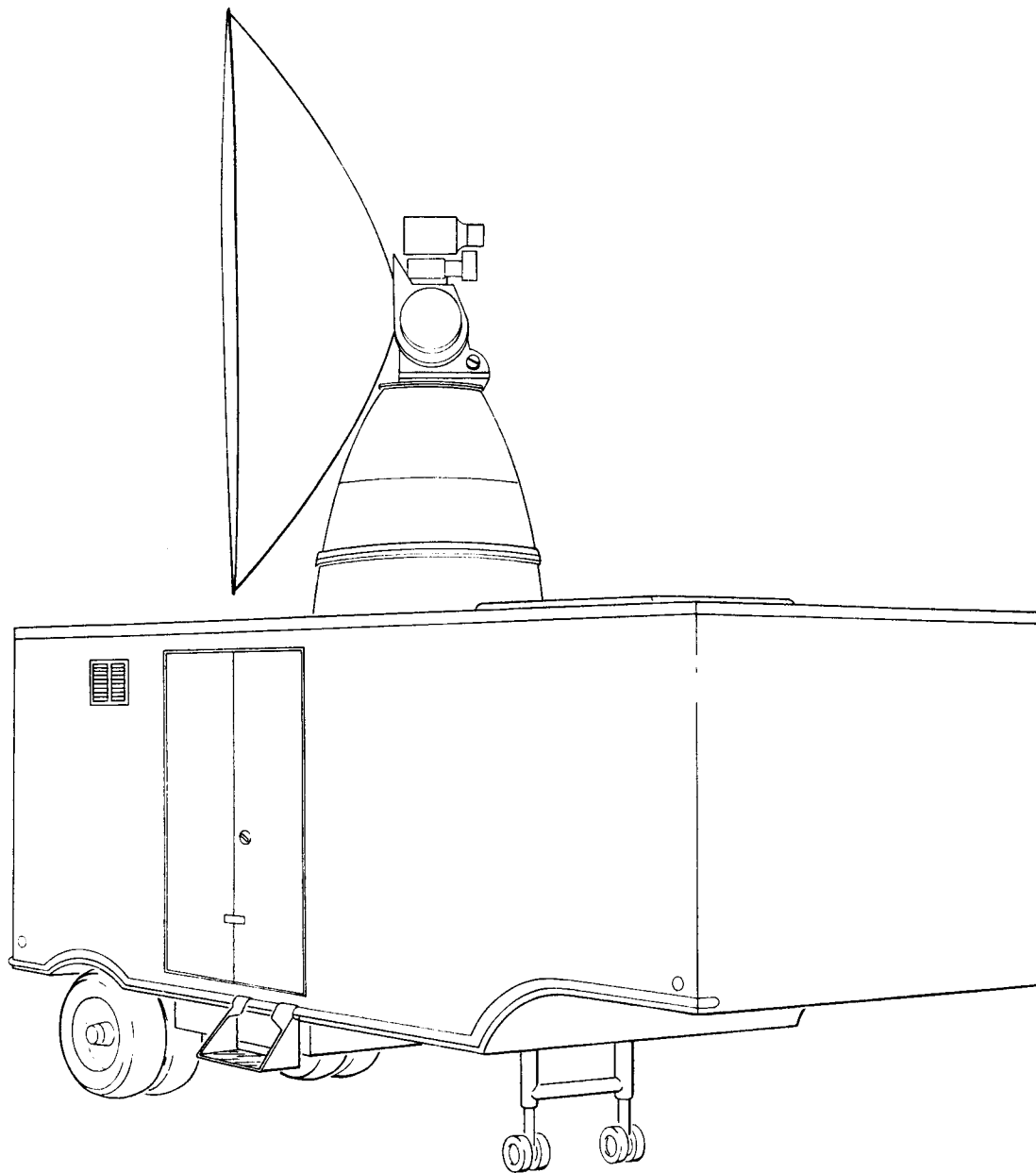

5680057

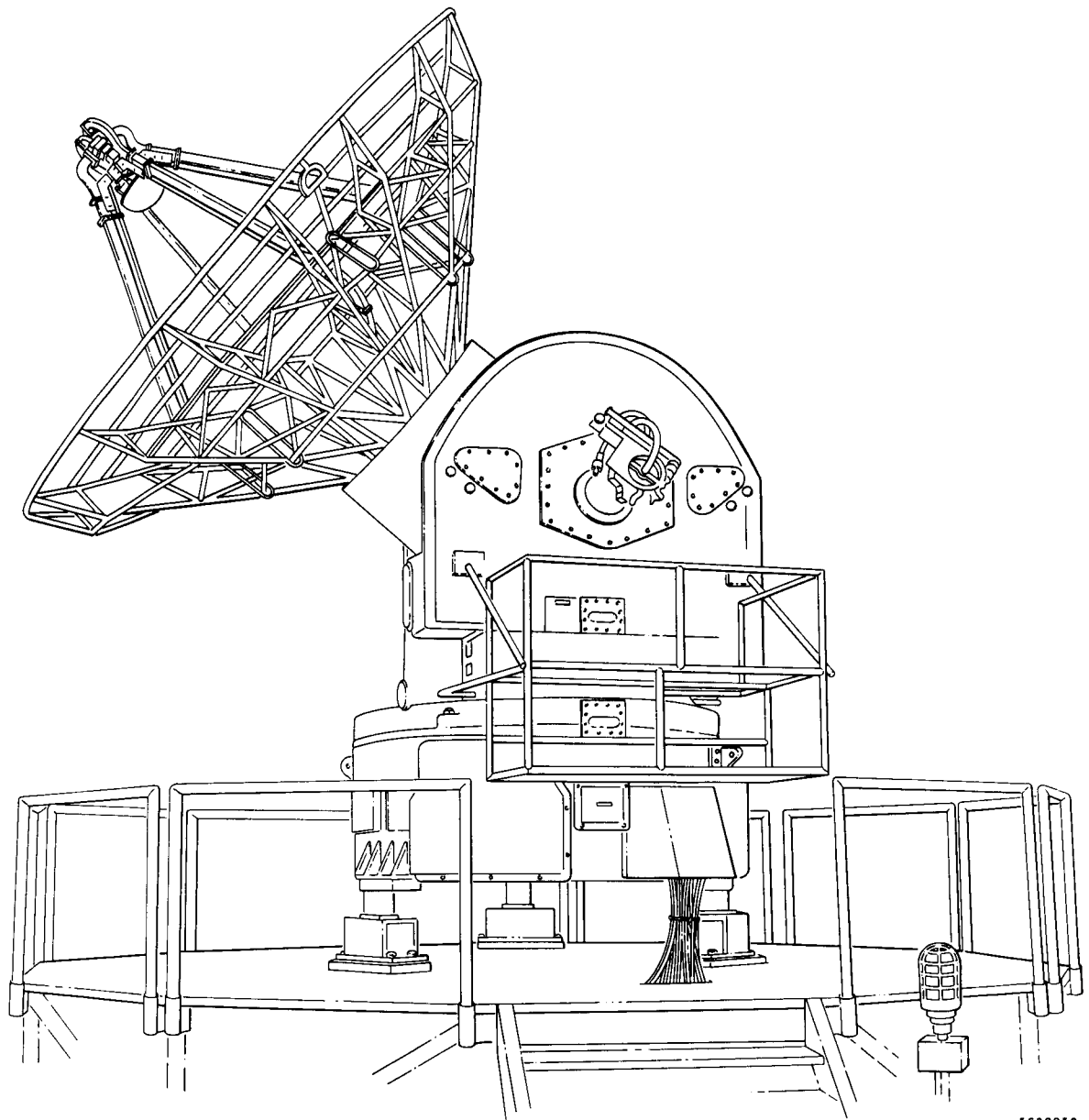

5680058



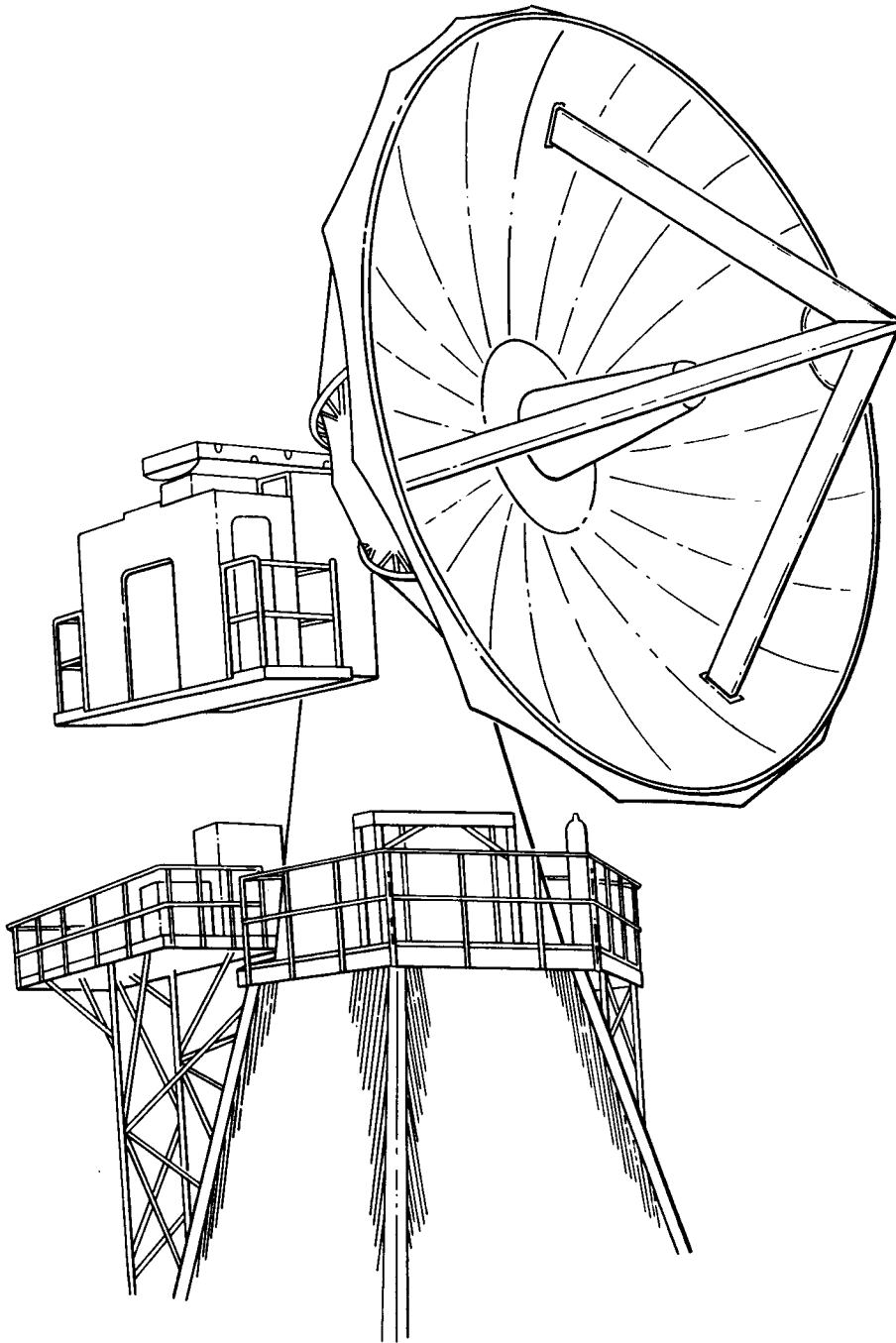

6315005

(HOURS)	(MINUTES)	(SECONDS)	(THOUSANDS OF YARDS)	(DEGREES)	(DEGREES)
H	M	S	R	AZ	EL
024	400		3033	233.1	0.1
024	500		2914	223.3	1.8
024	600		2877	212.9	2.9
024	700		2925	202.6	3.4
024	800		3053	192.9	3.3
024	900		3250	184.2	2.8
025	000		3501	176.6	1.8
025	100		3794	170.1	0.6

5680060

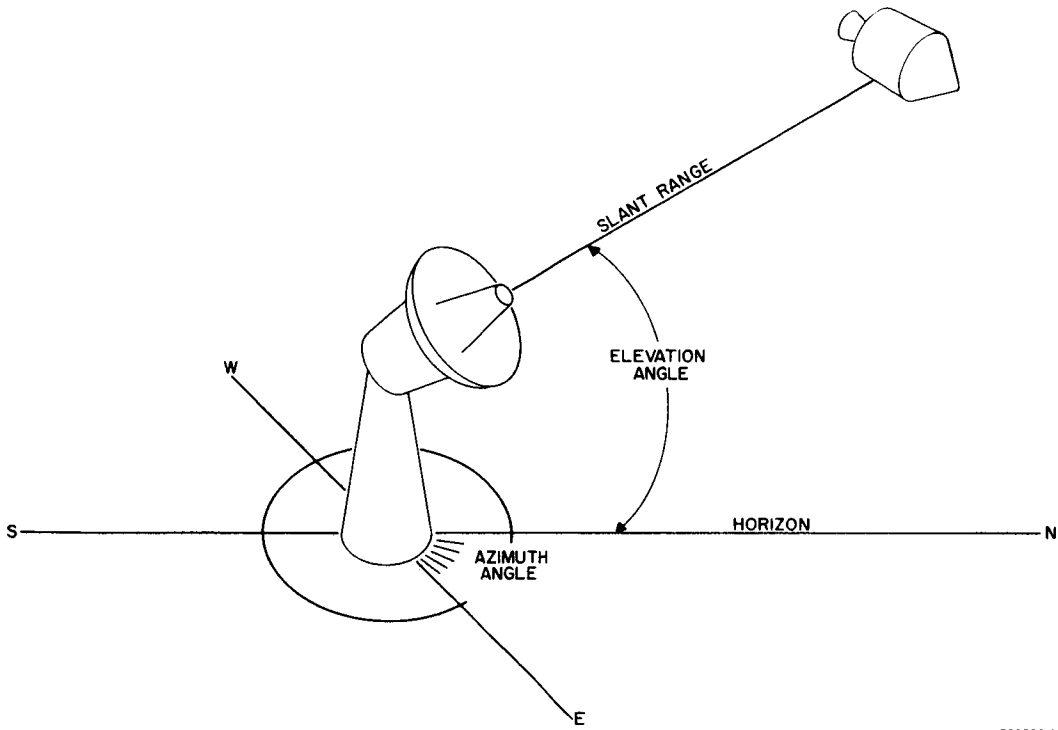

5093001A

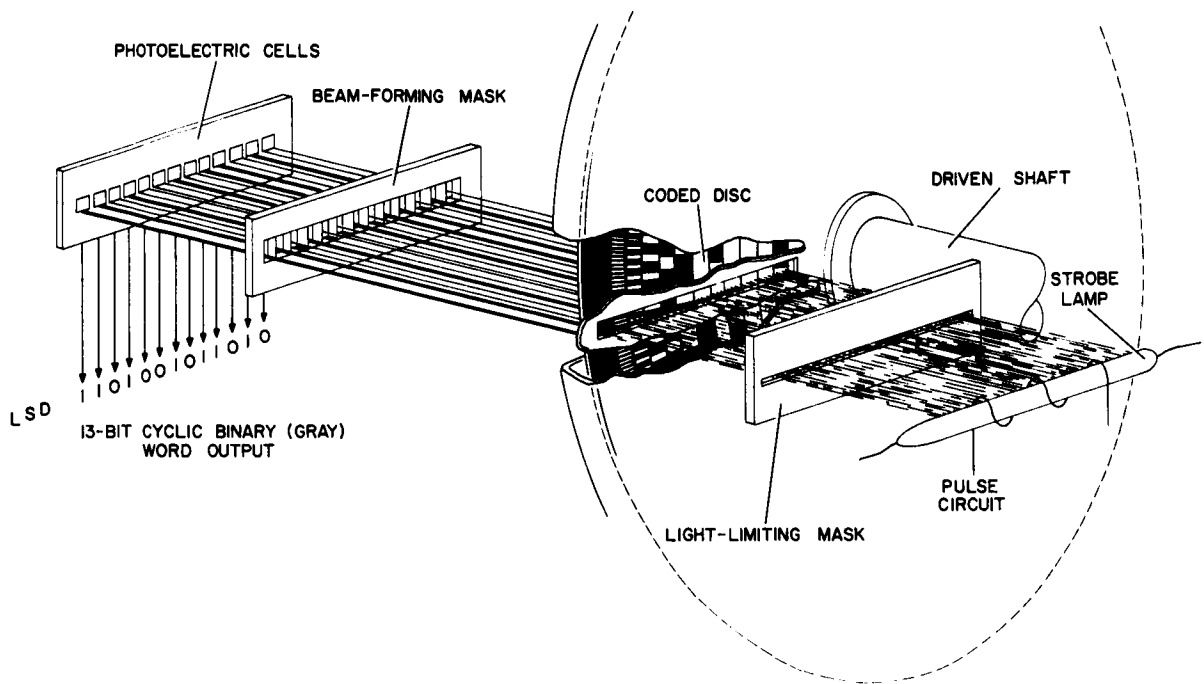

5680062

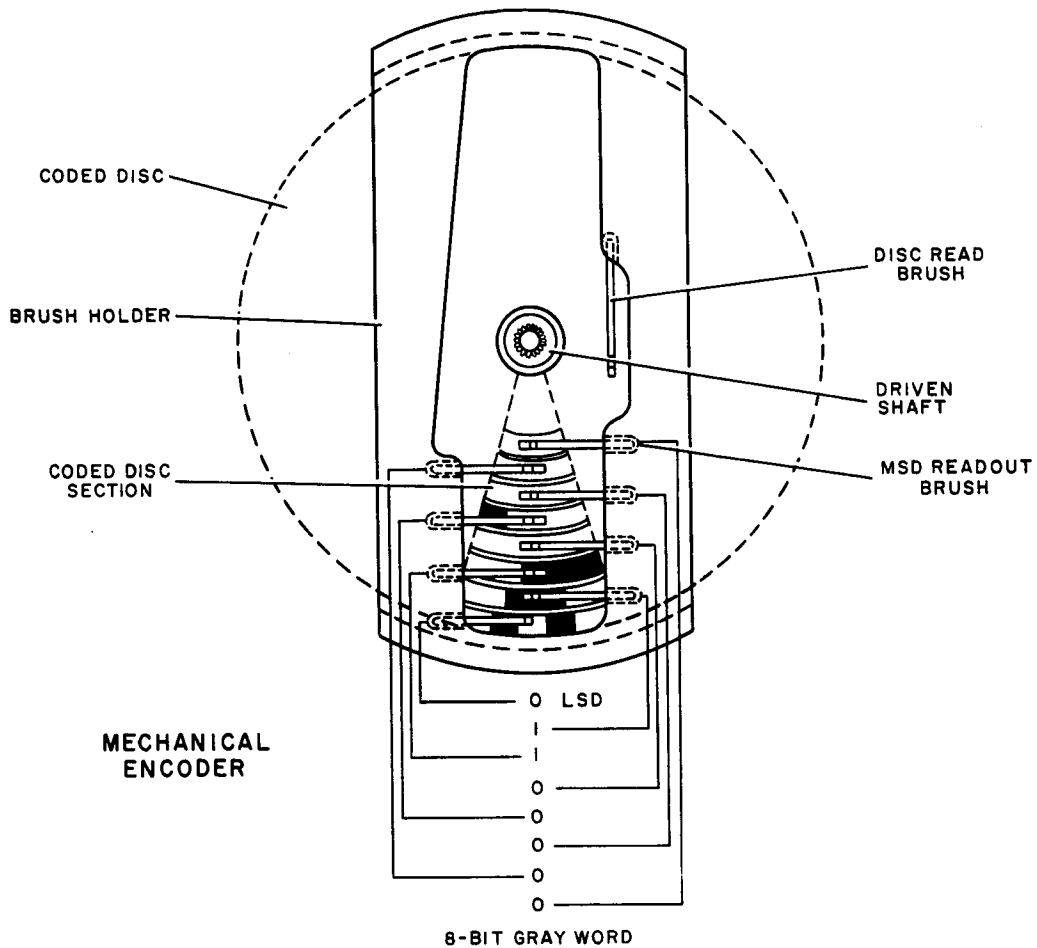

5880063

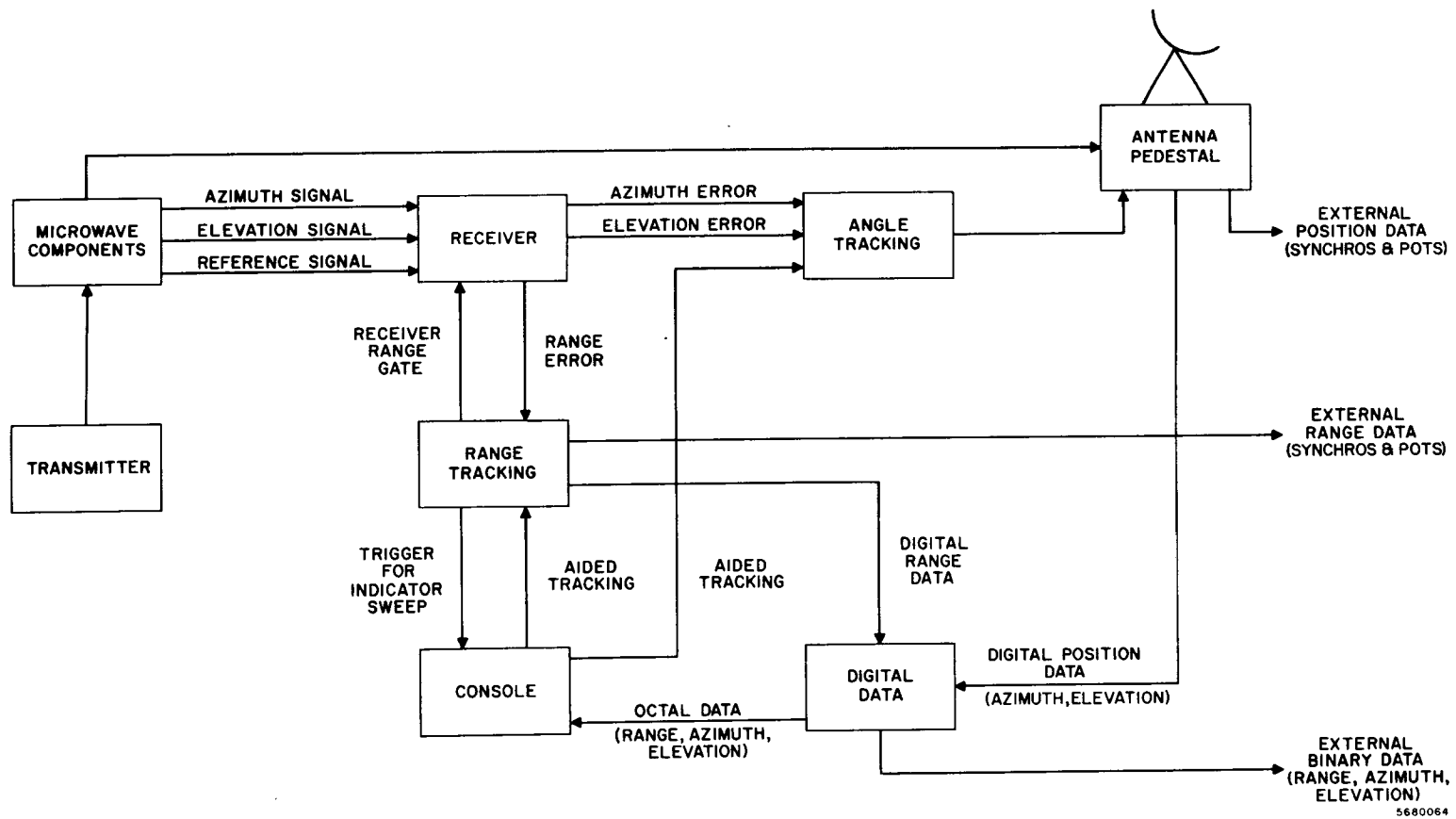

5680064

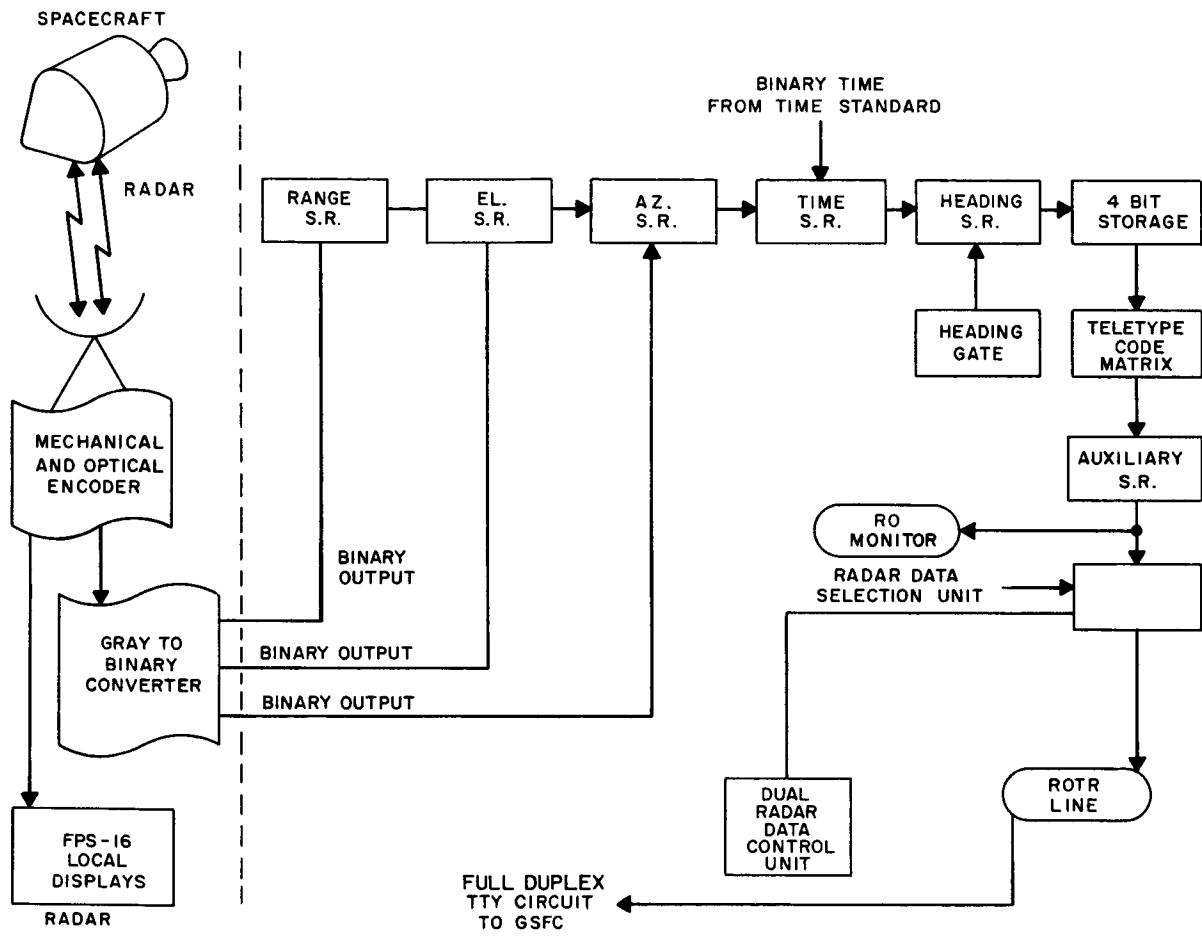

5093007

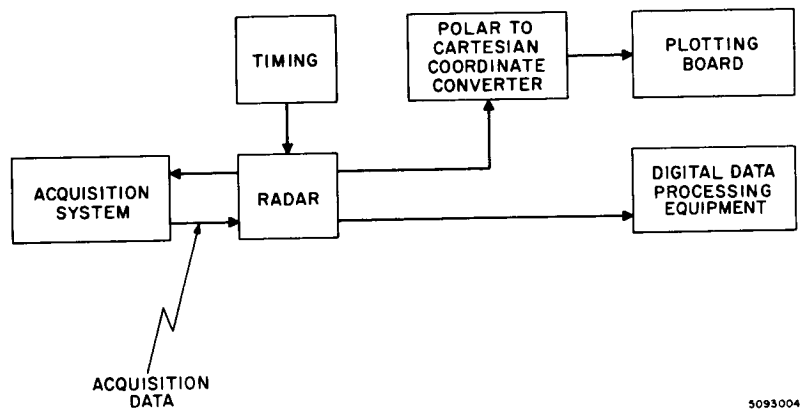



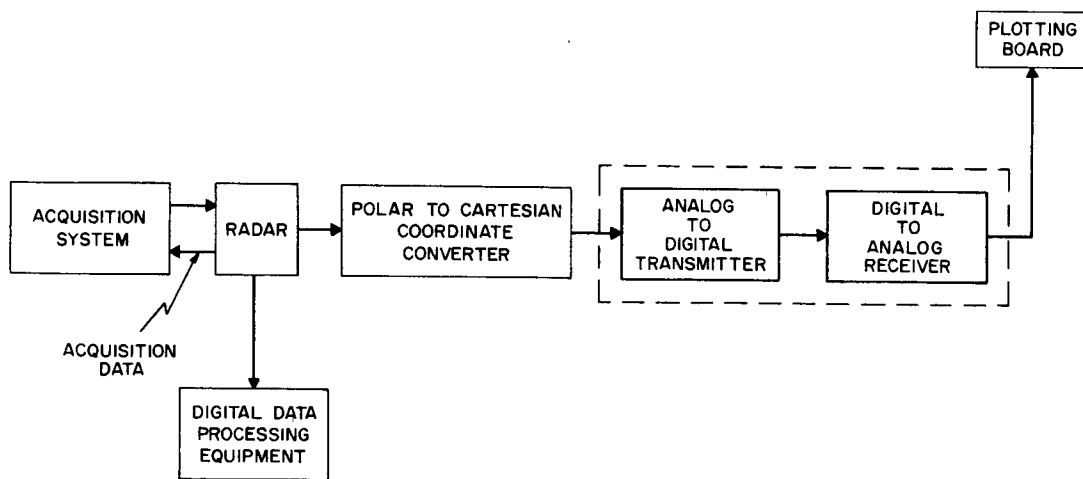

5093005

## BINARY-OCTAL-DECIMAL CONVERSION DATA

### 1. Gray-to-Binary Conversion

a. The least significant bit in the binary word can be determined by counting the 1's in the gray word. When the number of 1's is odd, the least significant binary bit will be a 1. An even number of 1's in the gray word causes the least significant binary bit to be a 0.

b. Place the least significant bit of the binary word under the least significant bit of the gray word. Add the 1's in the remaining gray word, excluding its least significant binary bit, to determine whether it is odd or even, remembering that the least significant gray bit having a binary bit beneath is not included in the count. Continue the procedure to determine all of the binary bits in succession.

Example:

Gray word	-	0010	0010	1000	0100	0001
Binary word	-	0011	1100	1111	1000	0001

### 2. Binary-to-Decimal Conversion

a. When the equivalent binary is obtained from the encoder outputs, the range and/or angle can be determined by referring to table 1 as illustrated in example of paragraph 2.b.

b. For each binary bit, refer to table 1 and tabulate as in the example below for total bit value.

Example:

Binary word - 0011 1100 1111 1000 0001

<u>Binary Bit Number</u>	<u>Range Yds.</u>
1 (least significant)	9.765625
8	1,250.
9	2,500.
10	5,000.
11	10,000.
12	20,000.
15	160,000.
16	320,000.
17	640,000.
18	1,280,000.
Total Bit Value	2,438,759.765625

3. Octal-to-Binary Conversion

- a. Convert octal to binary using table 1 below and record.

TABLE 1

<u>Octal</u>	<u>Binary</u>
0	000
1	001
2	010
3	011
4	100
5	101
6	110
7	111

Example of octal-to-binary conversion:

Octal - 0 1 6 1 6 0  
 Binary - 000 001 110 001 110 000

- b. For azimuth and/or elevation TTY readout, drop the least significant binary bit from paragraph 3. a. and record new binary word.

c. When the equivalent binary word is obtained from the TTY outputs, the range and/or angle bit values can be determined by referring to table 2 as illustrated in the example of paragraphs 3.d and 3.e.

d. For angle conversation, refer to table 2 and tabulate as in the example below for the total bit value:

Octal	-	0	1	6	1	6	0
Binary	-	000	001	110	001	110	000
New Binary	-	00	000	111	000	111	000

<u>Binary Bit Number</u>	<u>Angle Degrees</u>
4	0.04
5	0.09
6	0.18
10	2.81
11	5.62
12	<u>11.25</u>
Total Bit Value	19.99 Degrees

e. For range conversion refer to table 2 and tabulate as in the example below for total bit value:

Octal	-	0	0	1	6	1	6	0
Binary	-	000	000	001	011	001	110	000

<u>Binary Bit Number</u>	<u>Range Yds.</u>
5	156.25
6	312.5
7	625
11	10,000.
12	20,000.
13	<u>40,000.</u>
Total Bit Value	70,993.75 Yards

TABLE 2  
 BINARY BIT VALUE DIGITAL READOUT

<u>Binary Bit No.</u>	<u>Range</u>	<u>Degree</u>
19 (most significant range bit)	2,560,000	
18	1,280,000	
17	640,000	
16 (most significant angle bit)	320,000	180
15	160,000	90
14	80,000	45
13	40,000	22.5
12	20,000	11.25
11	10,000	5.62
10	5,000	2.81
9	2,500	1.40
8	1,250	0.70
7	625	0.35
6	312.5	0.18
5	156.25	0.09
4	78.125	0.04
3	39.0625	0.02
2	19.53125	0.01
1 (least significant bit)	9.765625	0.005

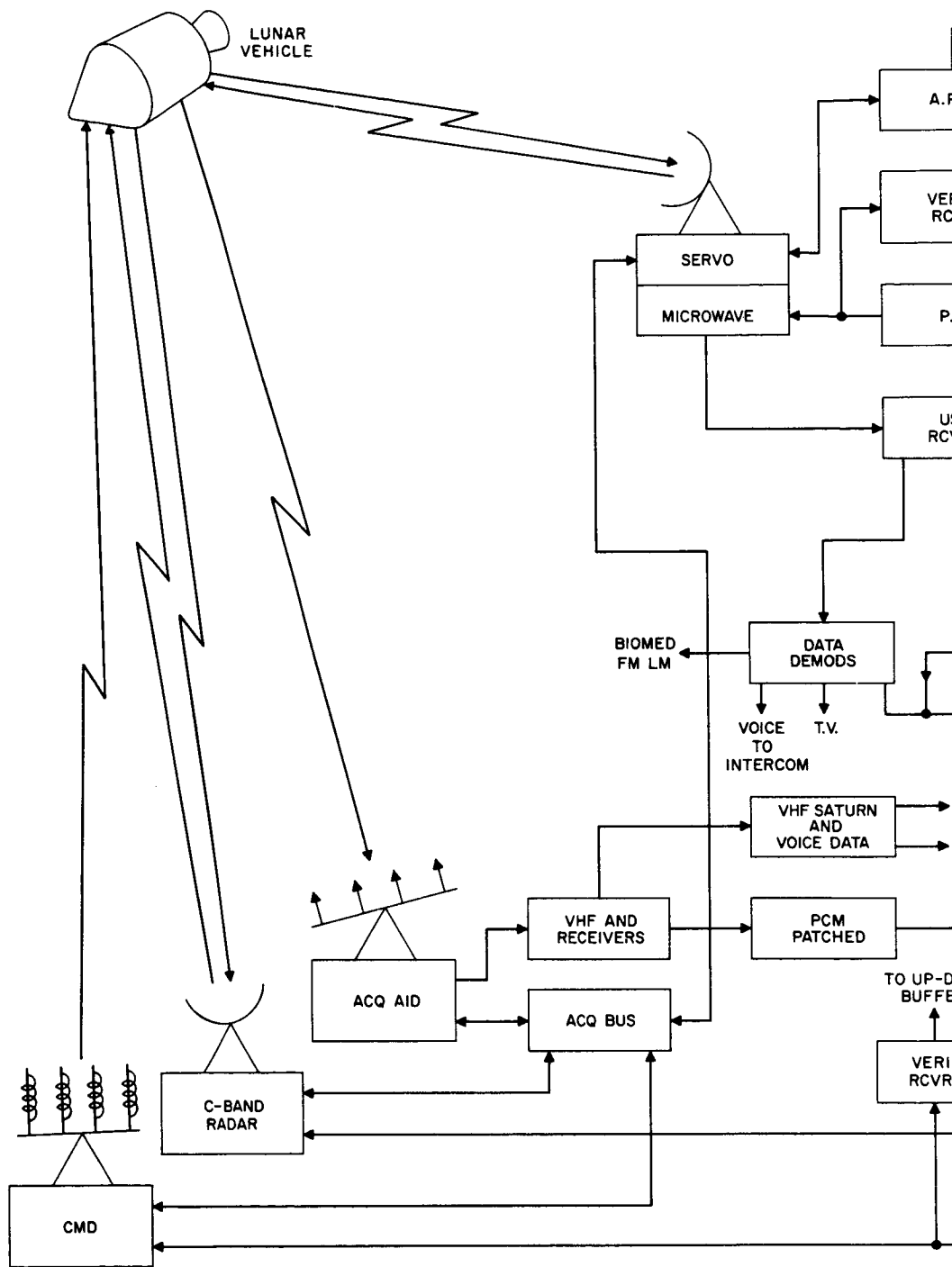

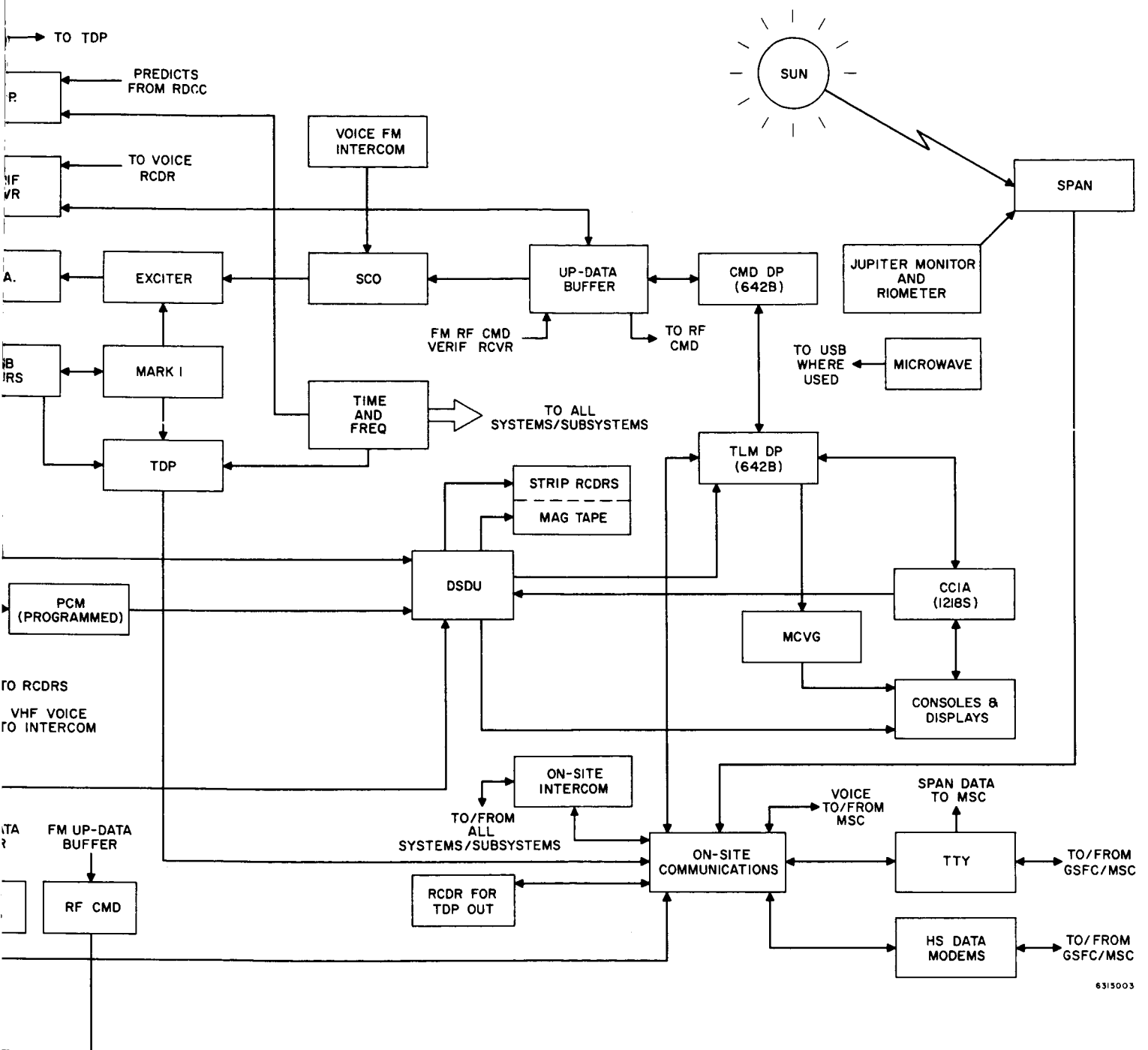

6315003

TRAINING USE ONLY

REMOTE STATION  
CONFIGURATION,  
BLOCK DIAGRAM AI-031

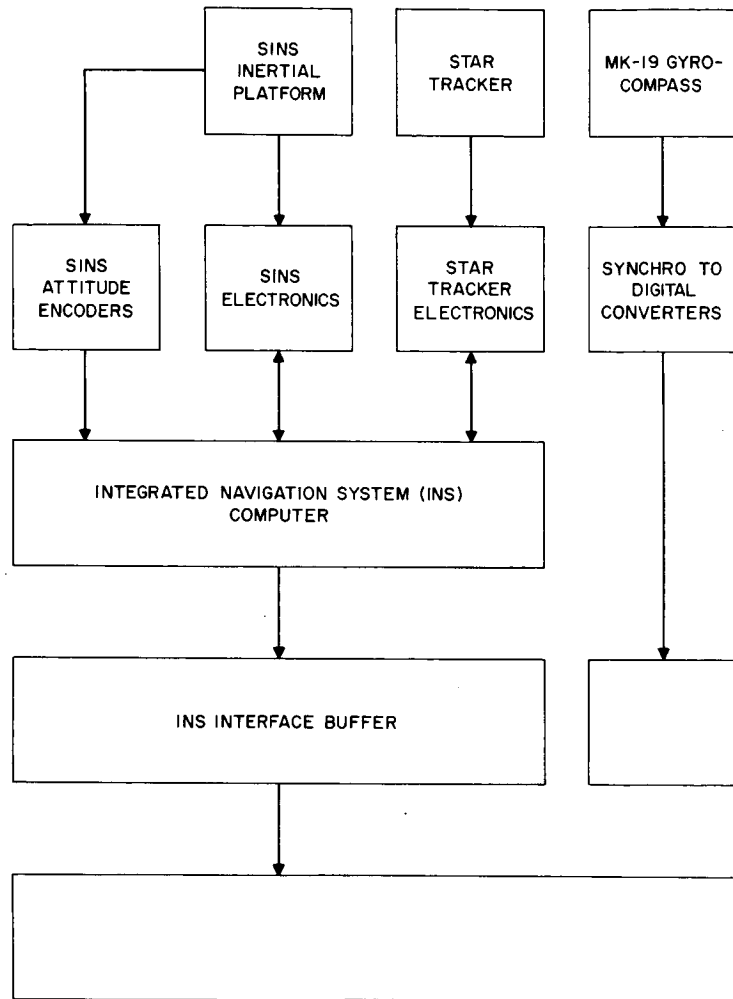



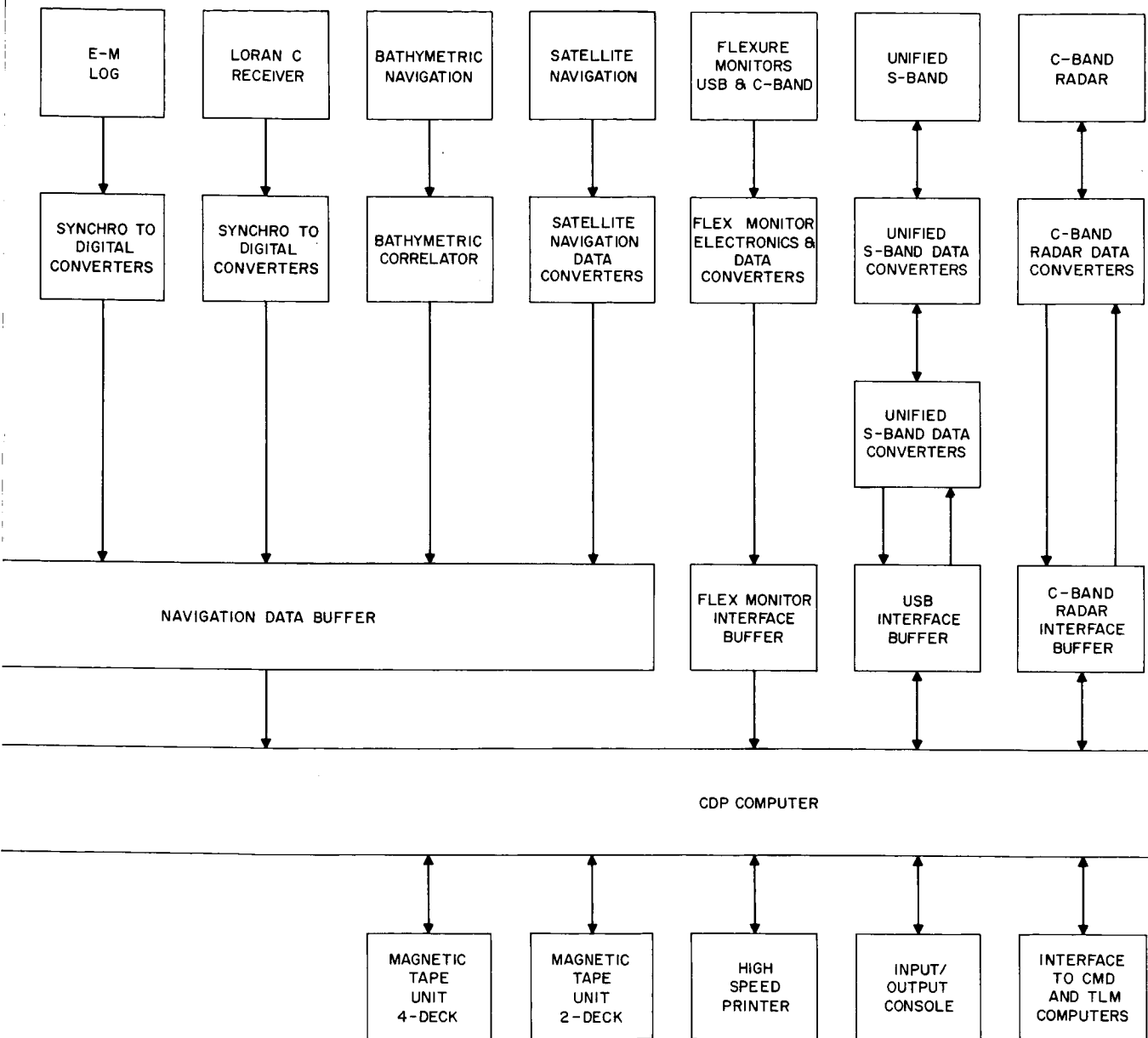

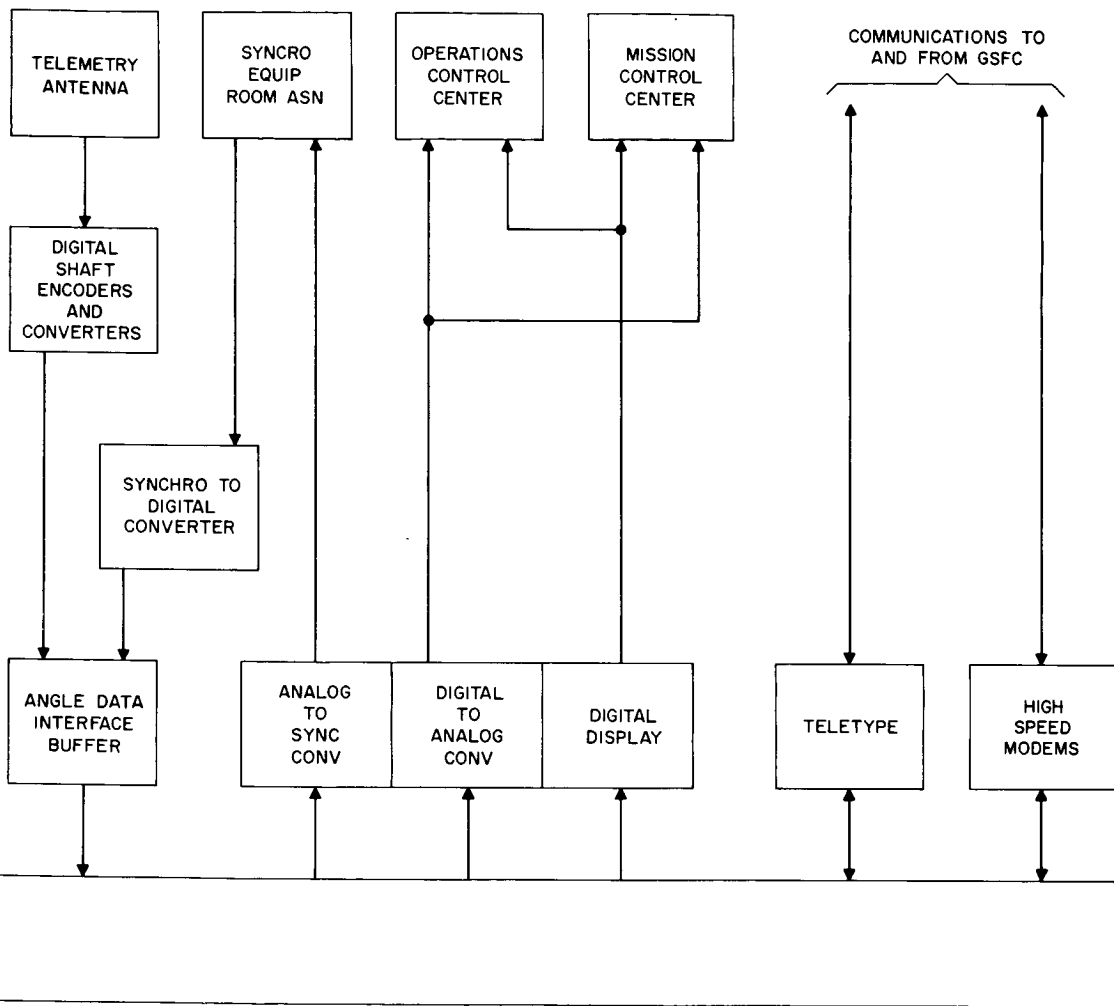

6223002

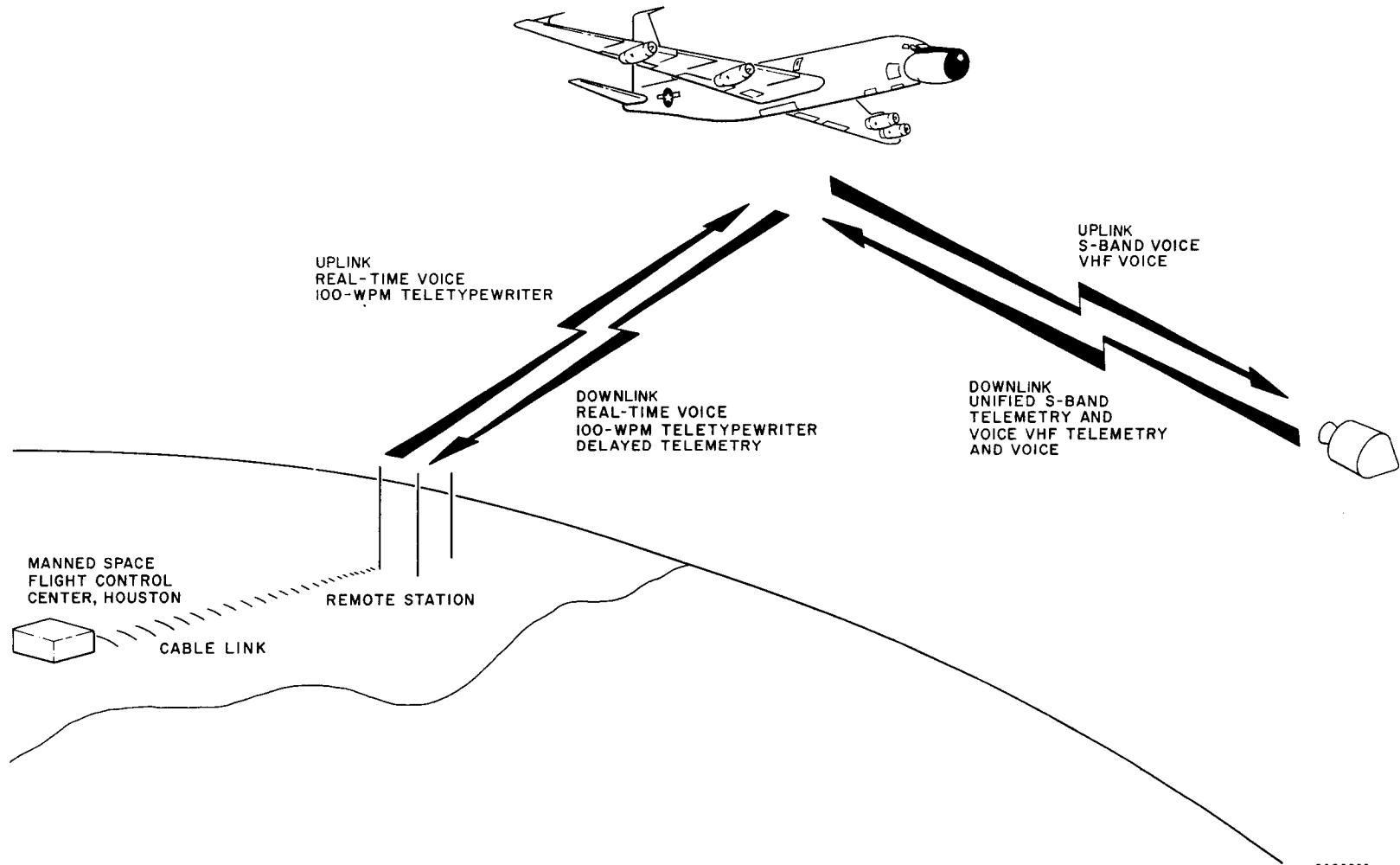

NETWORK TEST AND TRAINING FACILITY  
GODDARD SPACE FLIGHT CENTER  
GREENBELT, MARYLAND

INTRODUCTION TO THE UNIFIED S-BAND SYSTEM

The lunar phases of the Apollo missions require techniques and equipment exceeding the capability of those previously used in the Manned Space Flight Network. To fulfill this requirement, the Unified S-Band (USB) system has been introduced into the network. The USB system used with 85-foot antennas will provide the only means of tracking and communicating at lunar distances. The USB system with 30-foot antennas will be used to fill the gaps in the coverage provided by the three 85-foot antenna stations. The USB system with the 30-foot antennas will also be used to provide data during the launch, insertion, earth parking orbit(s) and injection phases of Apollo missions.

In order to insure reliability, the USB system utilizes existing, proven techniques and hardware. These items of equipment developed and used by the Jet Propulsion Laboratory and the Scientific Satellite Network have been adapted to the USB system. The more significant of this equipment is the range and range rate equipment supplied by the Jet Propulsion Laboratory to the program and the antenna systems which are nearly identical to those used in the Scientific Satellite program.

The USB system utilizes a single carrier frequency in each direction to provide tracking as well as communicating with the spacecraft. Voice and update data are frequency modulated onto subcarriers and then combined with the ranging data. This composite information is used to phase-modulate the transmitted carrier frequency. The received and transmitted carrier frequencies are coherently related. This allows measurements of the carrier doppler frequency by the ground station for determination of the radial velocity of the spacecraft.

In the transponder (spacecraft) the subcarriers are extracted from the RF carrier and detected to produce the voice and command information. The binary ranging signals, modulated directly onto the carrier, are detected by the wideband phase detector and translated to a video signal.

The voice and telemetry data to be transmitted from the spacecraft are modulated onto subcarriers, combined with the video ranging signals, and used to phase-modulate the downlink carrier frequency. The transponder transmitter can also be frequency-modulated for the transmission of television information or recorded data instead of ranging signals.

The basic USB system has the ability to provide tracking and communications data for two spacecraft simultaneously, provided they are within the beamwidth of the single antenna. The primary mode of tracking and communications is through the use of the PM mode of operation. Two sets of frequencies separated by approximately 5 megahertz are used for this purpose. In addition to the primary mode of communications, the USB system has the capability of receiving data on two other frequencies. These are used primarily for the transmission of FM data from the spacecraft.

The tracking and communicating with the spacecraft during the lunar missions will be provided by three primary deep-space facilities, employing 85-foot antennas, spaced at approximately equal intervals of longitude around the earth to provide the continuous coverage of the lunar missions. Three of the deep space instrumentation facilities (DSIF) located at approximately the same locations will be equipped to serve as secondary to the primary stations. Each of these facilities, both the primary and secondary stations, will be equipped to track and provide communications with both the Lunar Module (LM) and the Command Module (CM) simultaneously.

In addition to the stations with the 85-foot antennas, a number of other stations employing 30-foot antennas are also required in the network. These systems are needed for launch coverage in-flight checkout of the spacecraft, to fill gaps in the coverage of the three lunar stations, and to provide instrumentation coverage for testing the spacecraft in earth orbit.

4-3

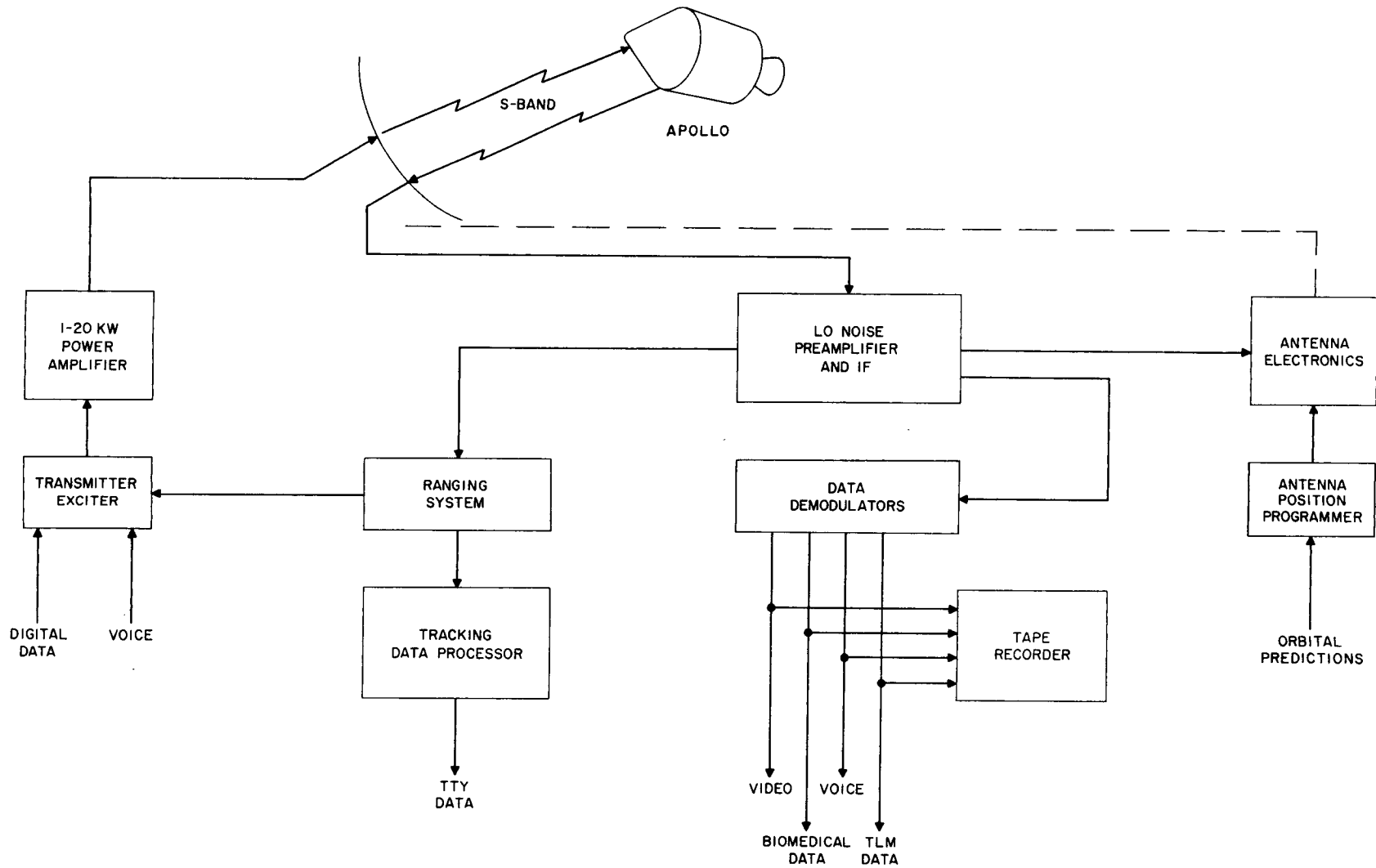

6315013

## UNIFIED S-BAND ANTENNAS

### INTRODUCTION

The following describes the main features of the Unified S-Band antennas, their design considerations, characteristics, parameters, functions, and modes of operation. This description covers 30-foot and 85-foot land-based X-Y mounts as well as the shipboard AZ-EL mounts.

### TYPES OF ANTENNA MOUNTS

Most steerable antennas have two mutually perpendicular rotational axes as shown in figure 1. The main difference between antenna mounts is the orientation of the lower of these two axes. There are three main types of antenna mounts.

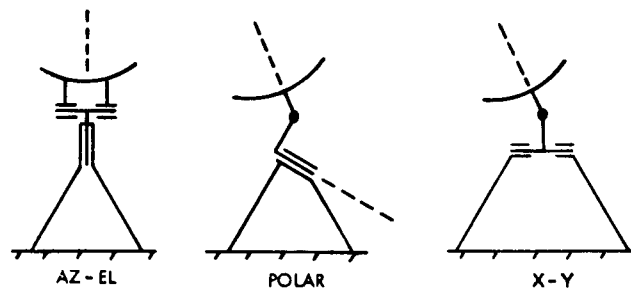

Figure 1 - Antenna mounts.

#### Azimuth-Elevation Mount

In the azimuth-elevation mount, the lower axis is vertical. This axis arrangement permits compactness of design and rigidity and it is the logical choice when tracking through zenith is not a requirement. It is by far the most popular mount. The problem is that extremely fast azimuth rates are required to track through zenith with the azimuth-elevation mount.

#### Polar (Hour Angle - Declination) Mount

In the polar mount the lower axis is parallel to the earth's rotational axis. This arrangement facilitates ease of tracking of celestial objects. It is used for radio telescopes and for antennas in the NASA deep space effort.

## X - Y Mount

Both axes of the X - Y mount are horizontal at zenith. The mount was designed especially for tracking earth satellites. Its main advantage is that it can track through zenith. All three types of mounts have gimbal lock positions at the ends of the lower axis. For the X - Y mount, these positions are half cones ( $10^{\circ}$  wide) just above the horizon (areas which are not greatly significant).

## LAND-BASED ANTENNAS

It has been established that all the Apollo land-based antennas must be capable of maintaining contact with the spacecraft through zenith (orbital transfer could occur at zenith) and essentially complete sky coverage is required. These requirements dictated selection of the X - Y mount for both the 30-foot and the 85-foot land-based antennas.

### 30-Foot Antenna

1. Three-foot diameter acquisition antenna at apex of quadripod.
2. Secondary reflector for Cassegrain feed system located just below acquisition antenna.
3. Y-axis (upper).
4. Y-wheelhouse (so-called cement mixer) which houses boresight package and equipment such as parametric amplifiers that should be near the feeds. This room is air conditioned by circulating a chilled glycol solution.
5. X-axis and X-wheel assembly which houses Y-axis drive assembly and provides access way for personnel to Y-wheelhouse.
6. Lower platform which provides mounting for X-drive units.
7. Room beneath antenna which houses power amplifier units and motor starters for drives.

### Main Reflector

1. The main reflector is made up of 36 solid surface panels. These panels are individually adjustable. Paint on the surface panels scatters solar radiation to prevent overheating feeds.



2. The feed cone mounted at center of dish.
3. Lights on rim of dish to warn when antenna may be transmitting. An audio warning is also used.

#### 85-Foot Antenna

The characteristics of the 85-foot antennas are essentially the same as those of the 30-foot antennas with the following exceptions:

1. Reflector is meshed rather than solid.
2. Absence of "cement mixer" appearance of Y-wheelhouse.
3. Six-foot diameter acquisition antenna at apex of quadripod.
4. Axis wheel structures for X and Y-wheelhouses are large space frames.

#### SHIPBOARD ANTENNAS

Although the X -Y antenna can track through zenith, it has some drawbacks. When it is designed for essentially complete sky coverage, the rotational axes are separated by a considerable distance. As a result, both axes must be counterweighted. This means that the design lacks compactness and the lower axis has a high moment of inertia. For shipboard application these disadvantages were judged to overshadow the advantage of being able to track through zenith (considering the fact that the ship location could possibly be changed to avoid an overhead pass). Therefore, azimuth-elevation mounts are used for the Apollo ships' antennas.

4-7

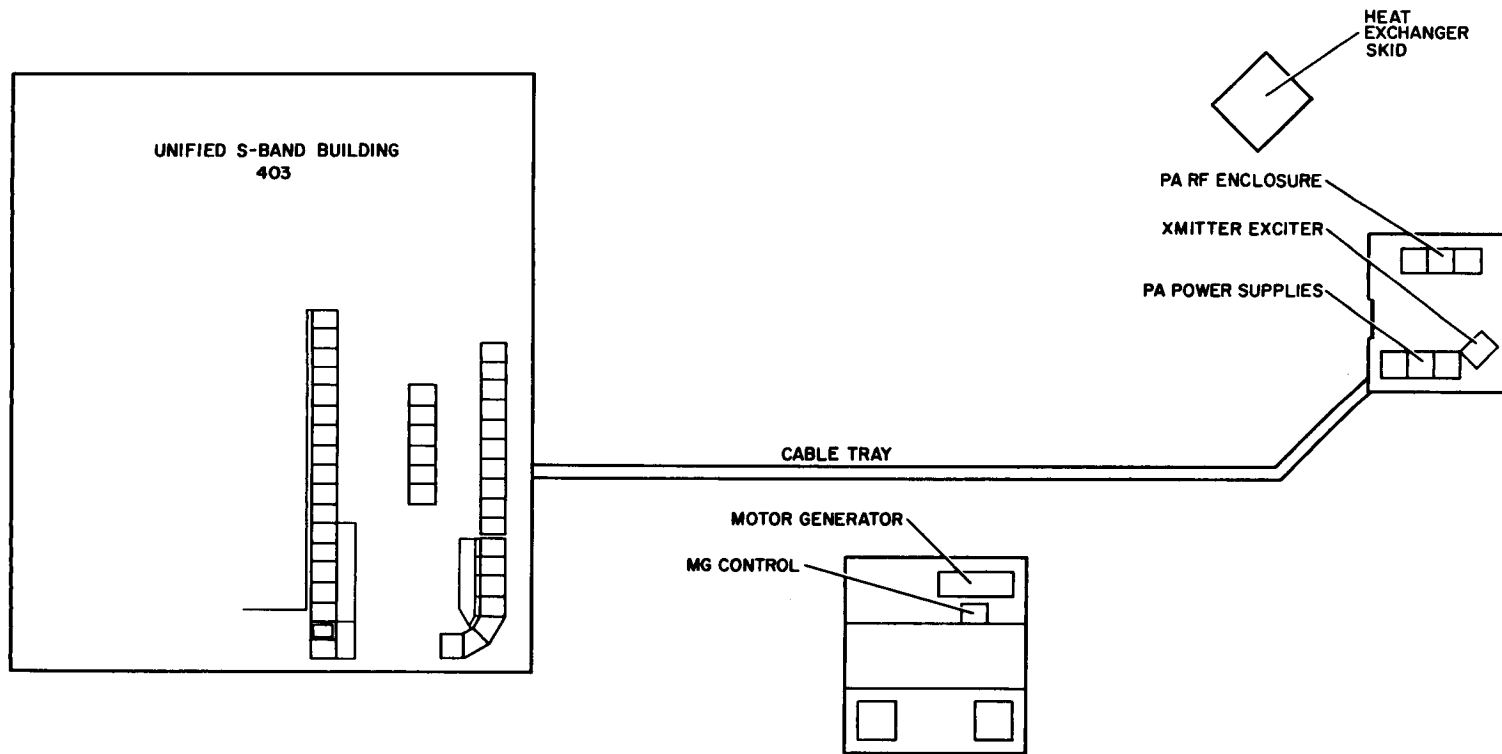

5626003

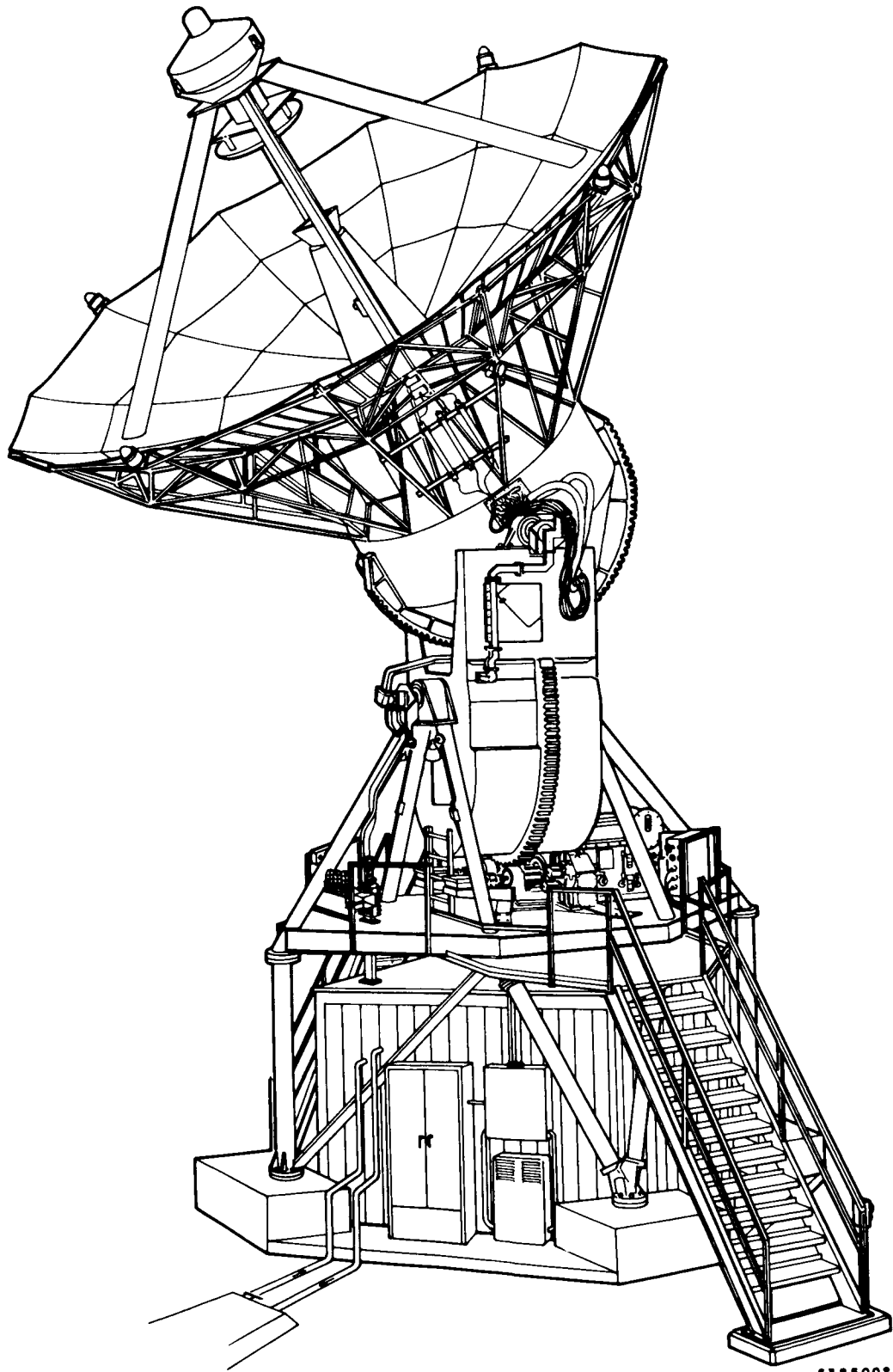

638602

UNIFIED S-BAND LAND BASED ANTENNA  
TECHNICAL CHARACTERISTICS

1. ANTENNA - 30' alum. and steel main dish.
2. GAIN - 43 db Xmt - 44 Rx.
3. FEED - 4 horn Cassegrain monopulse (dual freq. multi-mode).
4. POLARIZATION - Transmit - RH or LH circular. Selectable remotely.  
- Receive - RH or LH circular. Must be manually changed.
5. BEAM WIDTH - Main  $1^{\circ}$ .
6. RF POWER - Adjustable from 1 to 20 KW.
7. FREQUENCY - Transmit - 2101 to 2106 MC.  
- Receive - 2272, 2277, 2282, 2287 MC.
8. WEIGHT - 146,000 Lbs.
9. X BRAKING - Normal  $25^{\circ}/\text{Sec}^2$  - Emergency  $50^{\circ}/\text{Sec}^2$ , 290 Ft. Lbs.
10. Y BRAKING - Normal  $25^{\circ}/\text{Sec}^2$  - Emergency  $50^{\circ}/\text{Sec}^2$ , 130 Ft. Lbs.
11. DRIVE - Hydraulic (Dual Anti Back Lash).
12. TORQUE - Capable of holding antenna in winds up to 140 MPH at zenith.
13. MAX. X RATE -  $4^{\circ}/\text{Sec}$ .
14. MAX. Y RATE -  $4^{\circ}/\text{Sec}$ .
15. MAX. ACCELERATION -  $5^{\circ}/\text{Sec}^2$ .
16. ACQUISITION ANTENNA - 22 db gain -  $10^{\circ}$  beam width - 42" diameter.
17. TRACKING ACCURACY -  $.009^{\circ}$  - Slave  $.2^{\circ}$ .
18. SKY COVERAGE -  $2^{\circ}$  above horizon -  $360^{\circ}$  except in keyhole area which is  $8^{\circ}$   
high and  $20^{\circ}$  wide.
19. Y LIMITS -  $-82^{\circ}$ .
20. X LIMITS -  $-95^{\circ}$ .
21. STABILIZATION - Tach. Pos. feedback and hydraulic controlled antibacklash.
22. MODES OF OPERATION - Control, Operation, and Test.
23. OUTPUT DATA - Optical 18 bits and sign bit - 3 LSB in gray code.
24. STATIC DEAD ZONE -  $.002^{\circ}$ .
25. SETTLING TIME - 1.5 Sec. with full bandwidth selected.

ANTENNA SYSTEM PERFORMANCE

Criteria	30 Ft.	85 Ft.	Units
Velocity	4	3	Degrees/Second
Acceleration	5	5	Degrees/Second <sup>2</sup>
Winds: Operating	20	20	MPH
reduced Operating accuracy	45	45	MPH
Stowing	60	60	MPH
Survival	140	120	MPH
Sky Coverage	2	2	Degrees Above Horizon
Keyhole Cone	20	20	Degrees
Keyhole Orientation	North-South Axis	East-West Axis	
Accuracy: Pointing	±0.6	±0.6	Minutes
Tracking	1.5 max.	1.5 max.	Minutes

4-111

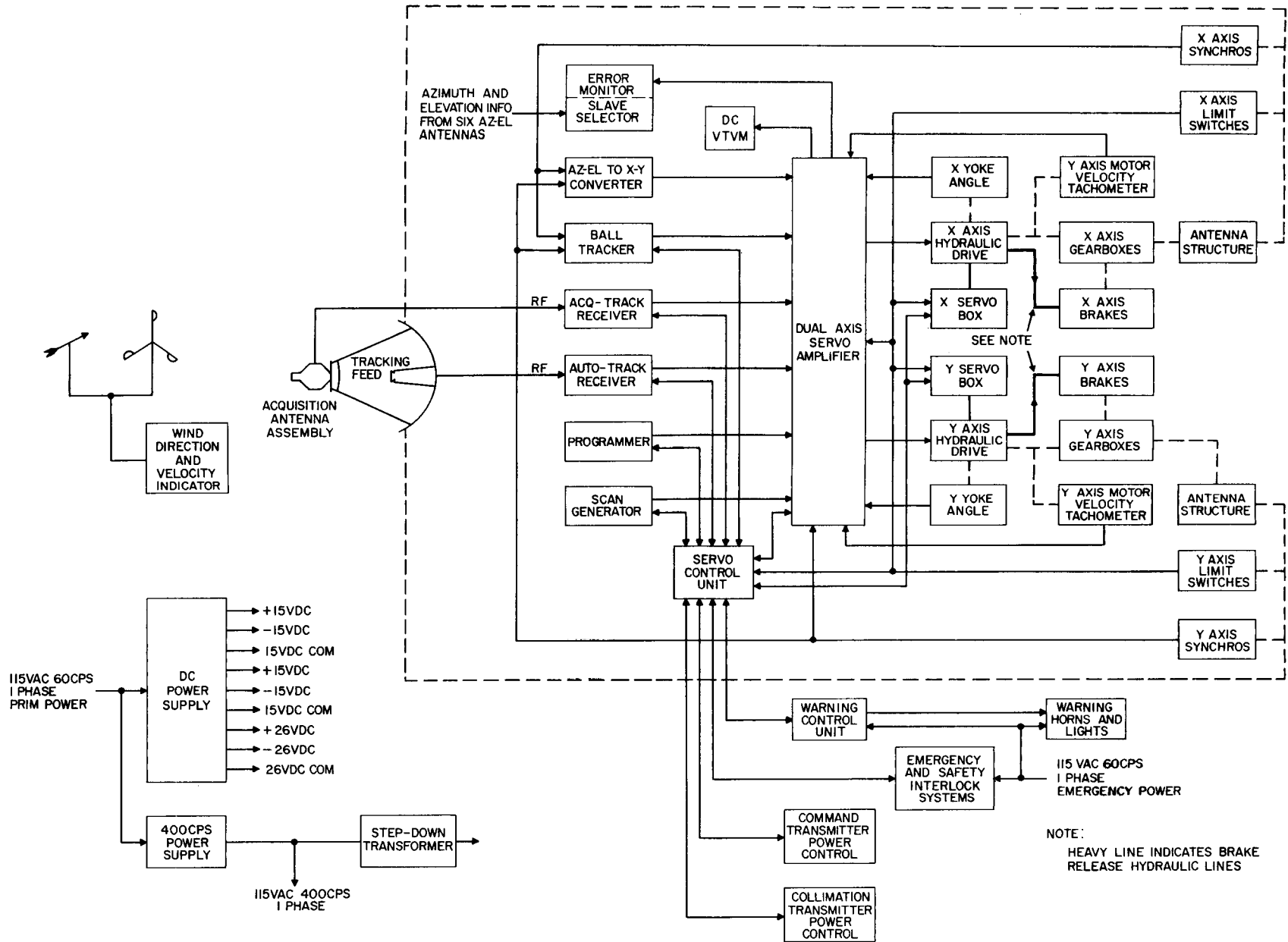

5680315

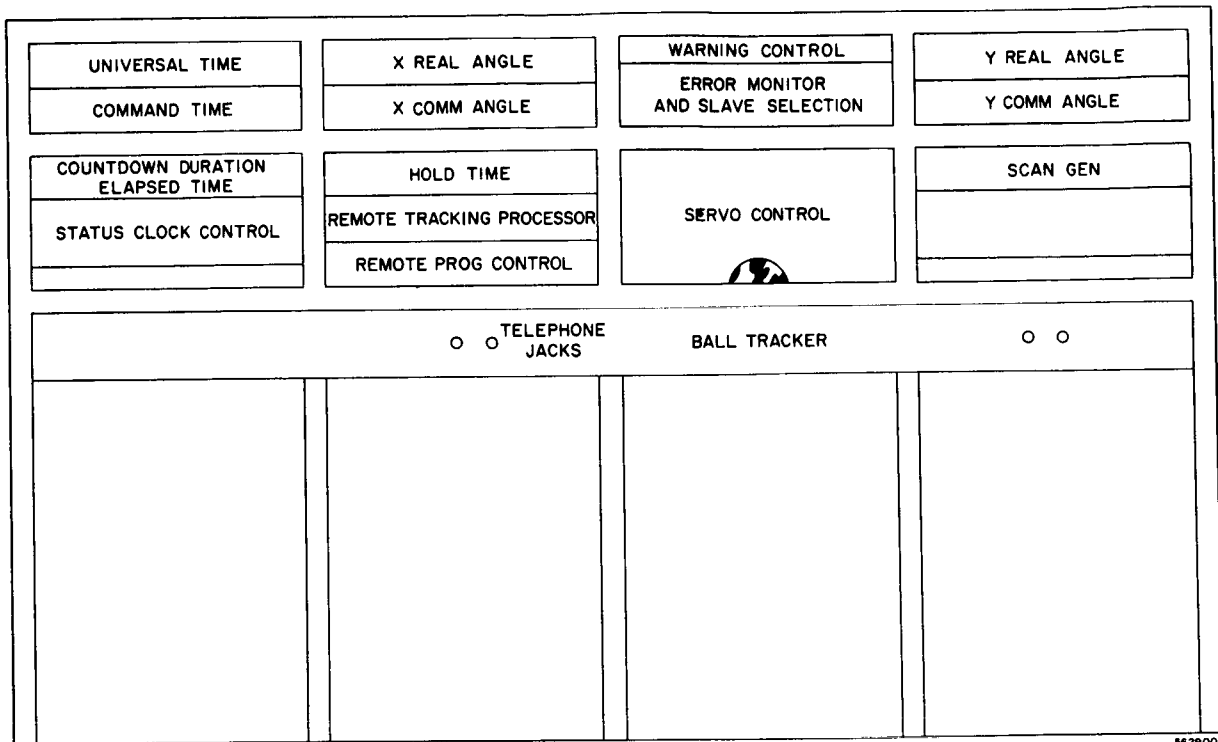

5629007

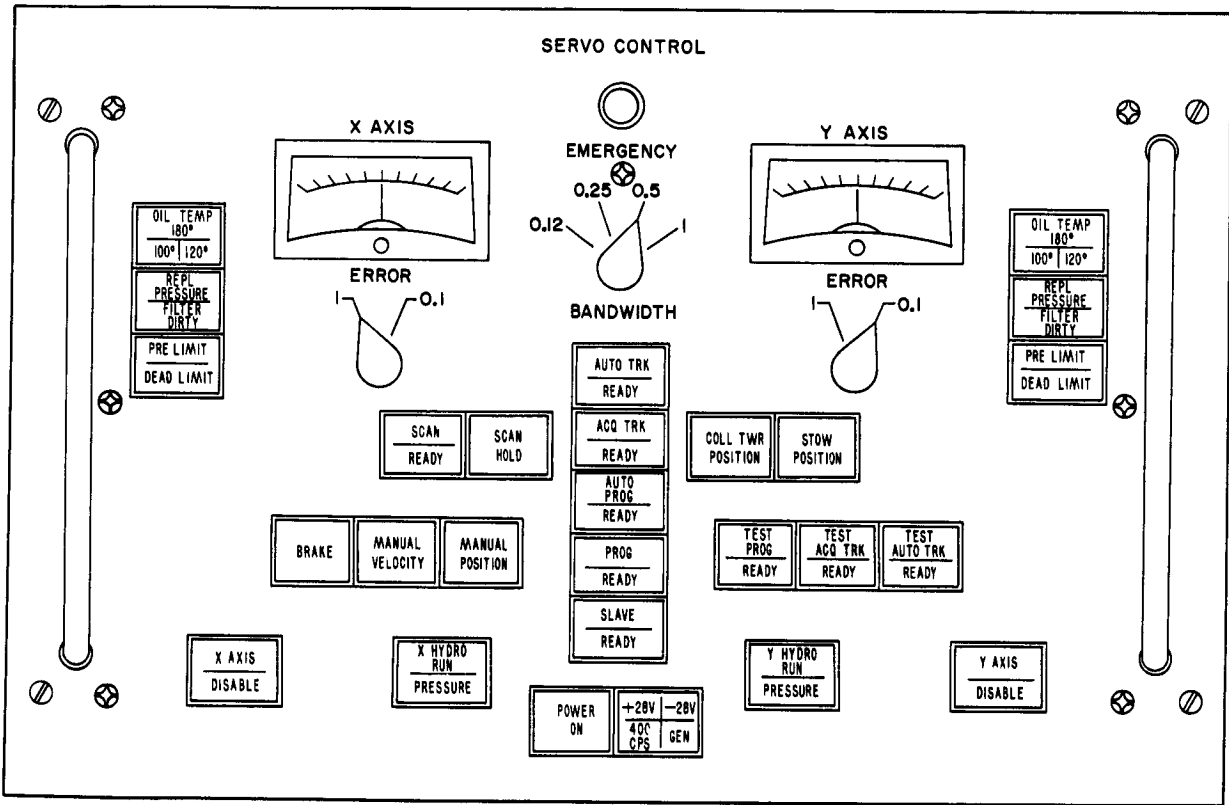



4-14

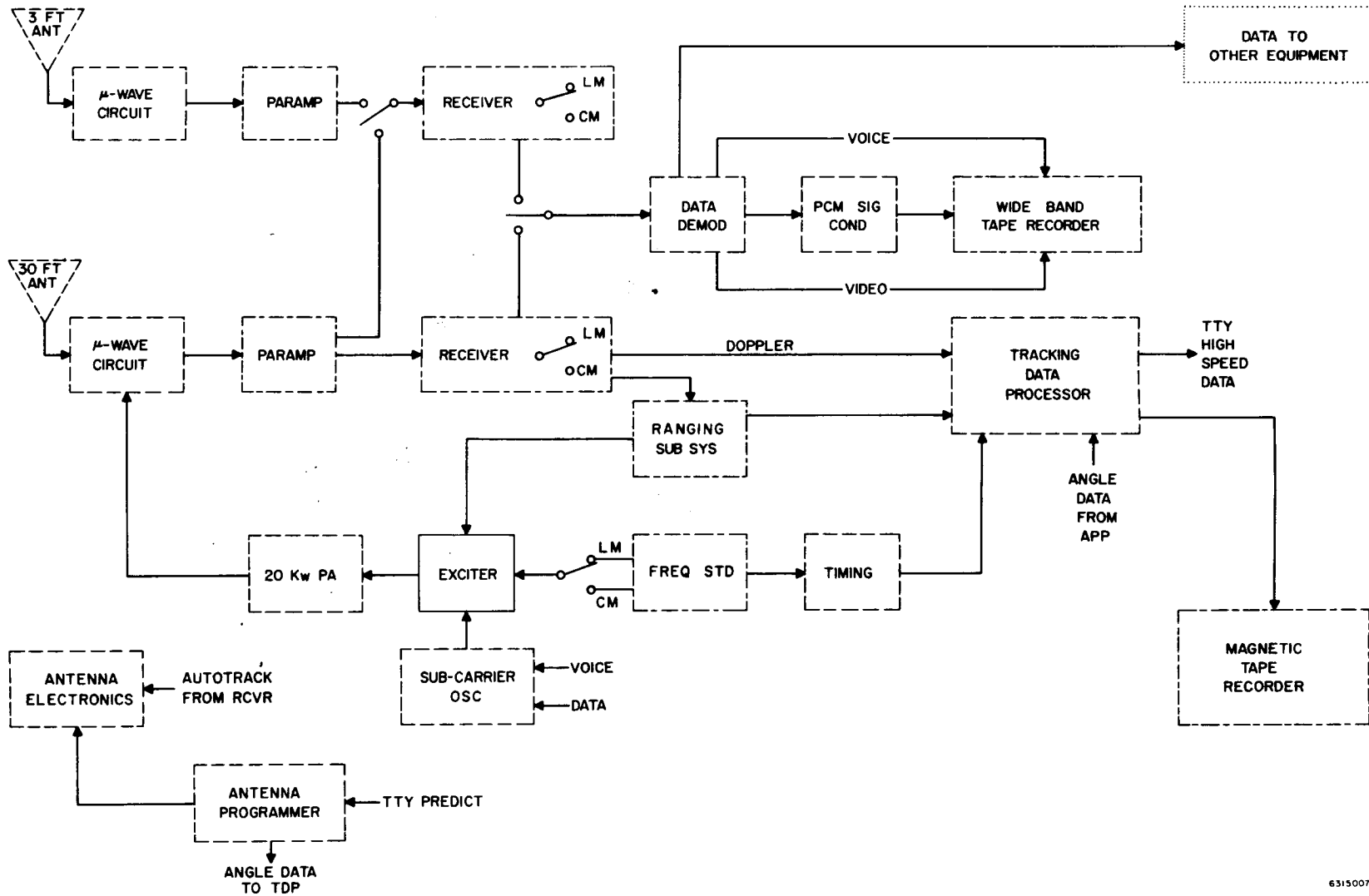

6315007

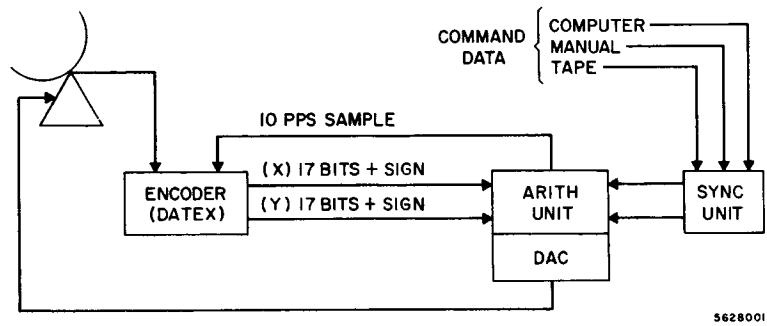

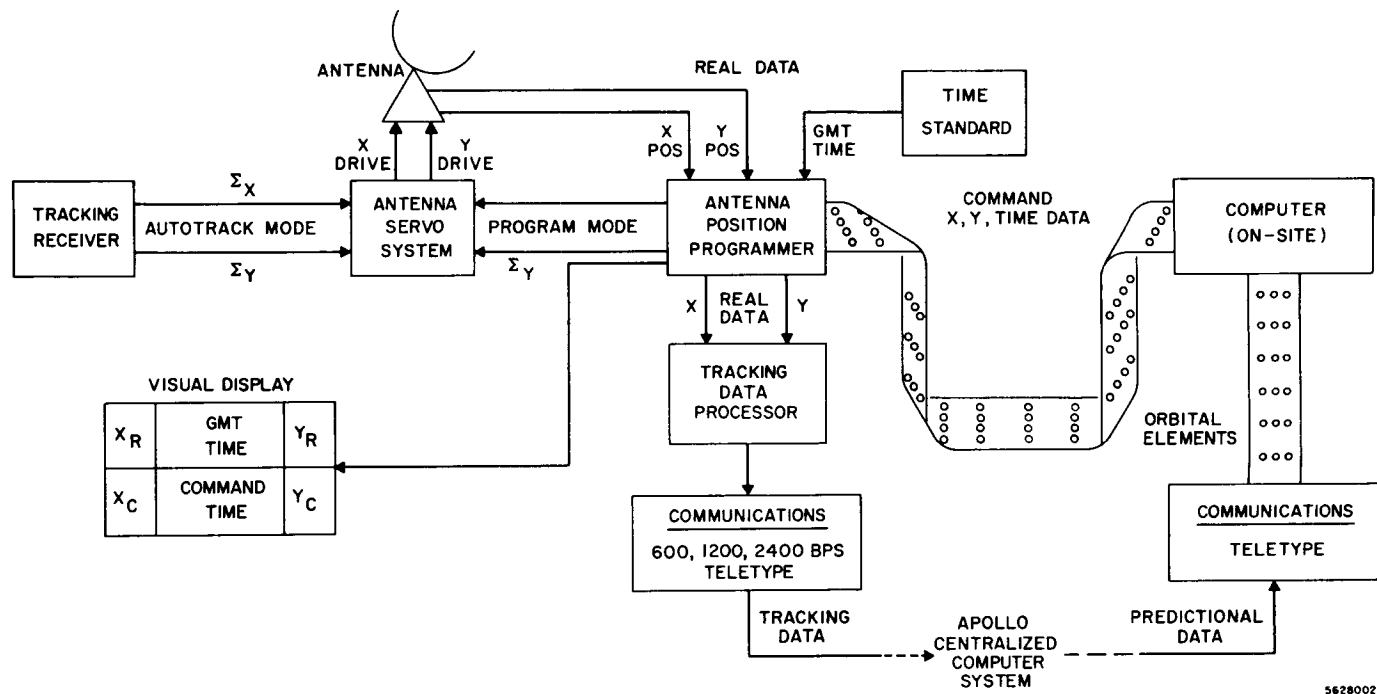

5628002

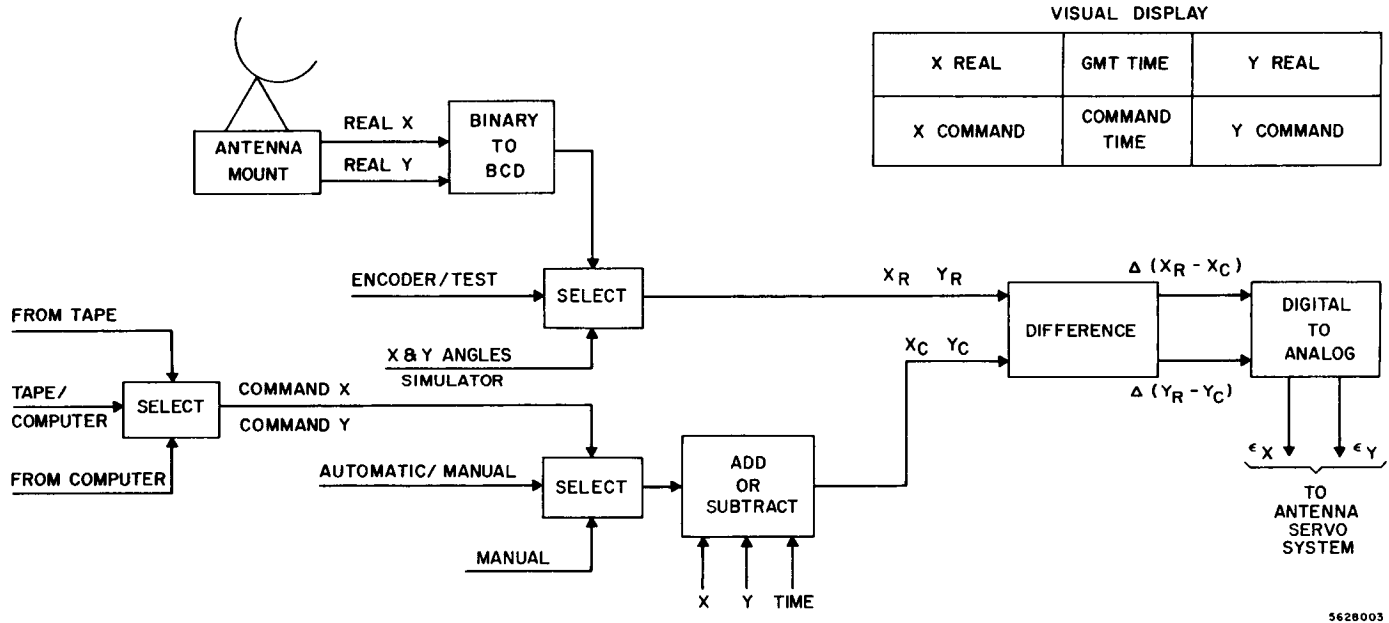

VISUAL DISPLAY

X REAL	GMT TIME	Y REAL
X COMMAND	COMMAND TIME	Y COMMAND

5628003

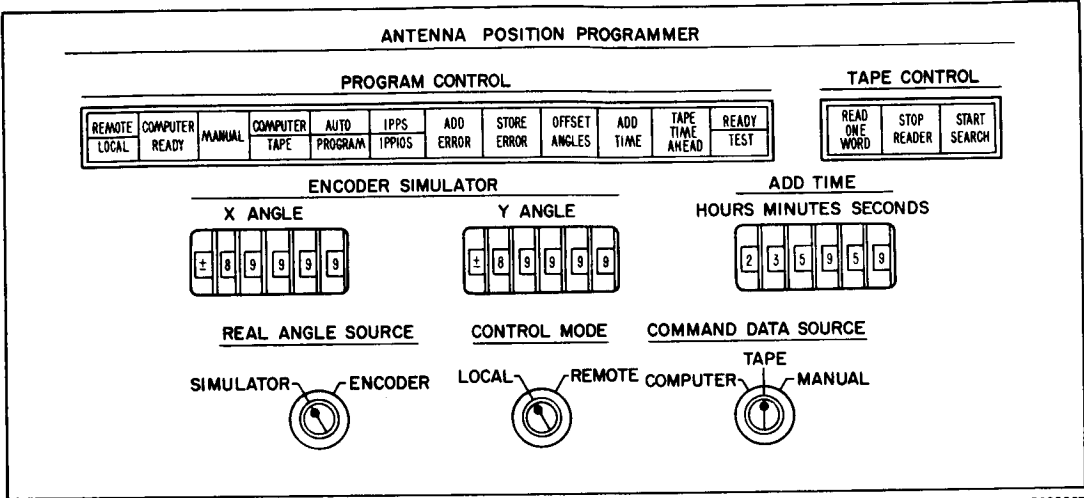

5628007

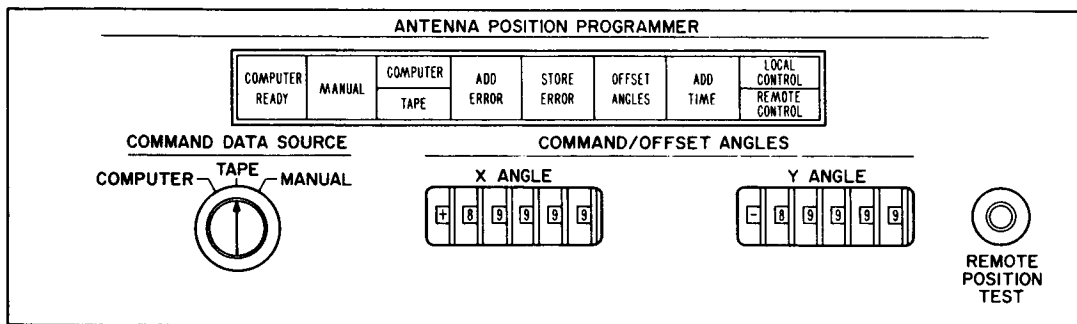

5628006

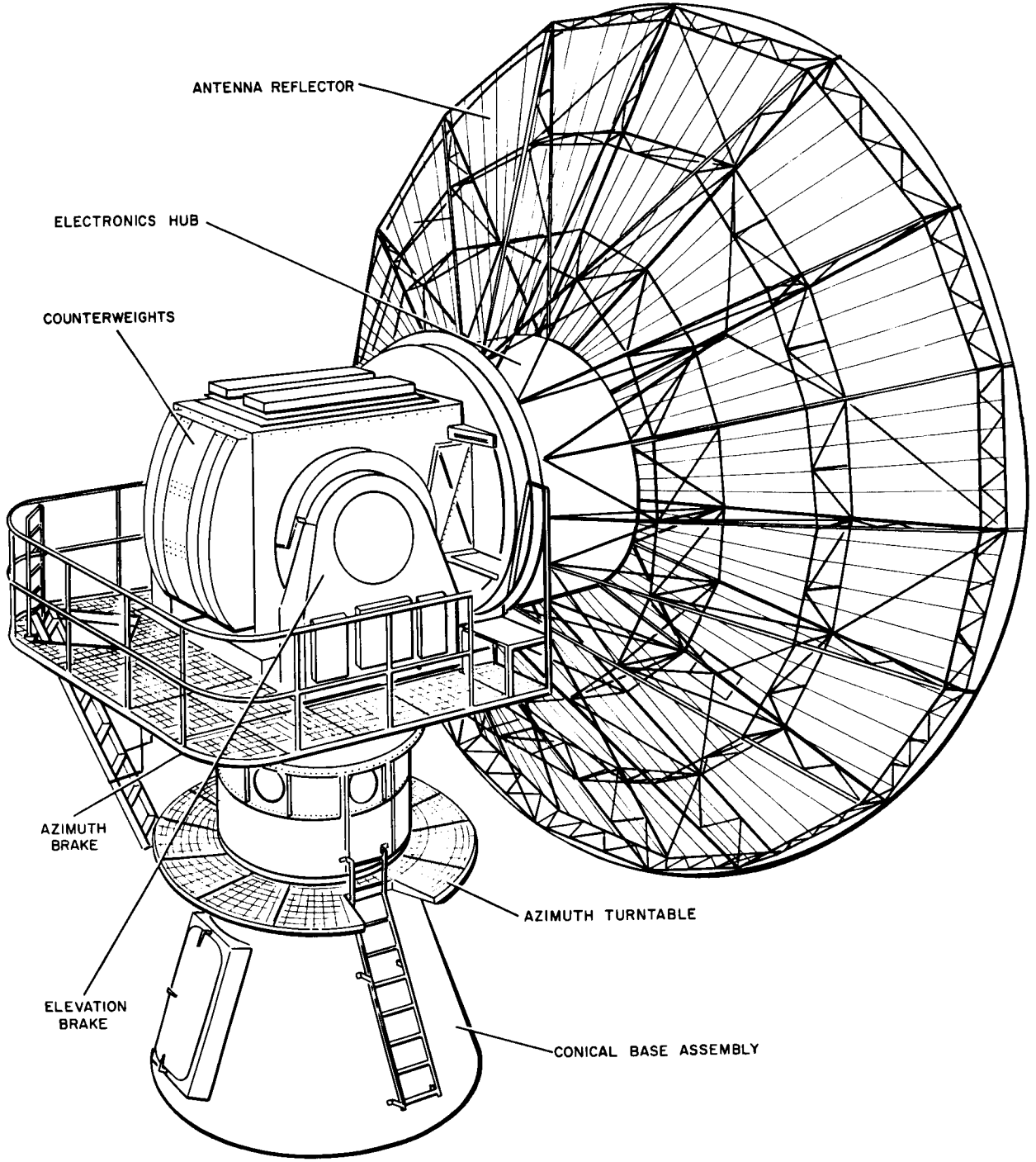

5665002

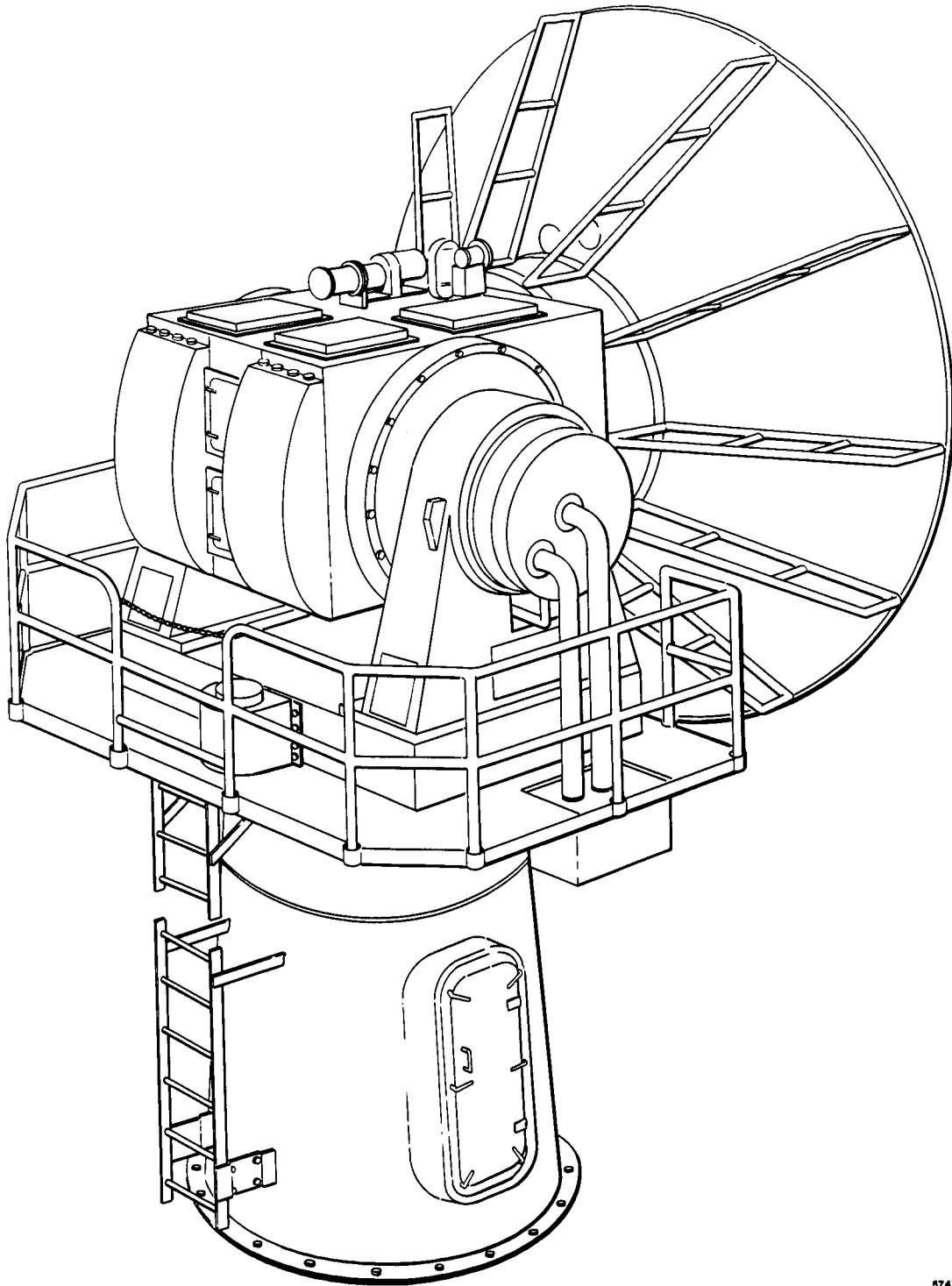

6747001



UNIFIED S-BAND SHIPBOARD ANTENNA  
TECHNICAL CHARACTERISTICS

1. ANTENNA - 30' Alum.
2. GAIN - 43 db.
3. FEED - Four horn Cassegrain monopulse (Dual frequency multi-mode).
4. POLARIZATION - Transmit - RH or LH circular. Selectable at Control Console. - Receive - RH or LH must be manually switched.
5. BEAM WIDTH -  $1.1^{\circ}$  -  $1.5^{\circ}$  (Main Dish).
6. SIDE LOBES - First 18 db down below main. All others 30 db down below main.
7. DEPTH OF NULL - 35 db.
8. RF POWER - 10KW average (Adjustable 1 to 20KW).
9. FREQUENCY - Transmit - 2090 - 2120MC.  
- Receive - 2270 - 2300MC.
10. WEIGHT - 100,000 lbs.
11. AZ BRAKING - 12K Ft. Lbs. (Total 72,000 Ft. Lb.).  
- 6:1 Ratio.
12. EL BRAKING - 12K Ft. Lbs. (Total 90,000 Ft. Lb.).  
- 3:1 Ratio.
13. DRIVE - dc Torque Director.
14. TORQUE - 26,000 Ft. Lbs. Cont.  
- 52K Peak.
15. MAX AZ RATE -  $56^{\circ}$  Per Second.
16. MAX EL RATE -  $33^{\circ}$  Per Second.
17. MAX ACCELERATION -  $50^{\circ}/\text{Sec}^2$ .
18. MIN. SMOOTH RATE -  $.001^{\circ}/\text{Sec}$ .
19. NATURAL RESONATE FREQUENCY - Greater than 20 cps.
20. ACQUISITION ANTENNA - 30' Inches Diameter,  $10^{\circ}$  Beam Width, 22 db gain.
21. TRACKING ACCURACY - .1m Rad.
22. REPEATABILITY -  $.001^{\circ}$ .
23. SKY COVERAGE -  $2^{\circ}$  to  $86^{\circ}$ .
24. ELEVATION LIMITS -  $15^{\circ}$  ( $105^{\circ}$  -  $180^{\circ}$ ).
25. AZIMUTH LIMITS - NONE.
26. STABILIZATION - Ships inertial navigation system internal.

27. MODES OF OPERATION - Primary with Gyro feedback test with tachometer feedback, utility with tachometer feedback.
28. OUTPUT DATA - Optical 18 bit True binary.
29. SLIP RINGS - 286 Total
  - 4 In Motors
  - 24 Shielded
  - 240 Non-shielded
  - 18 High Current

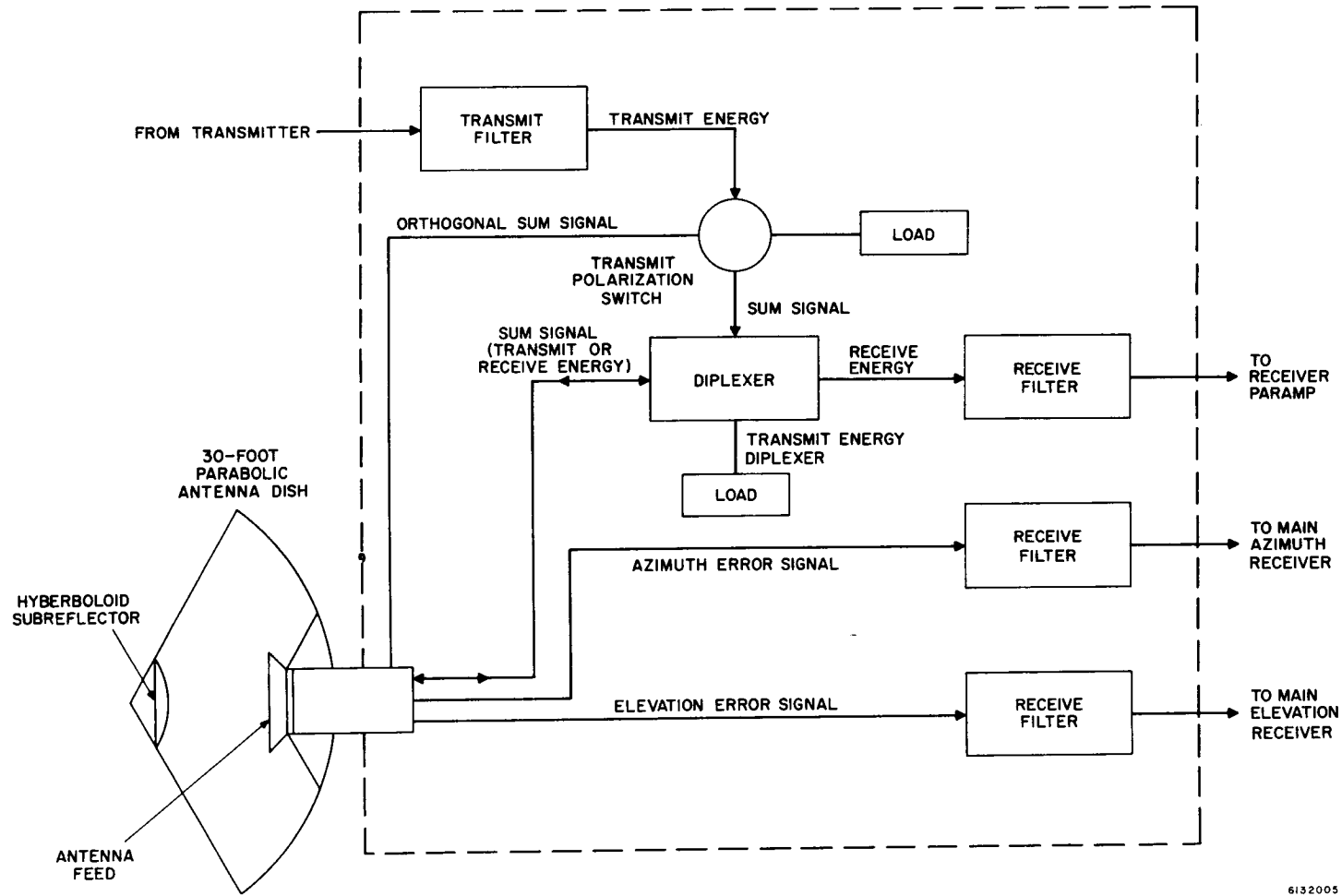

6132005

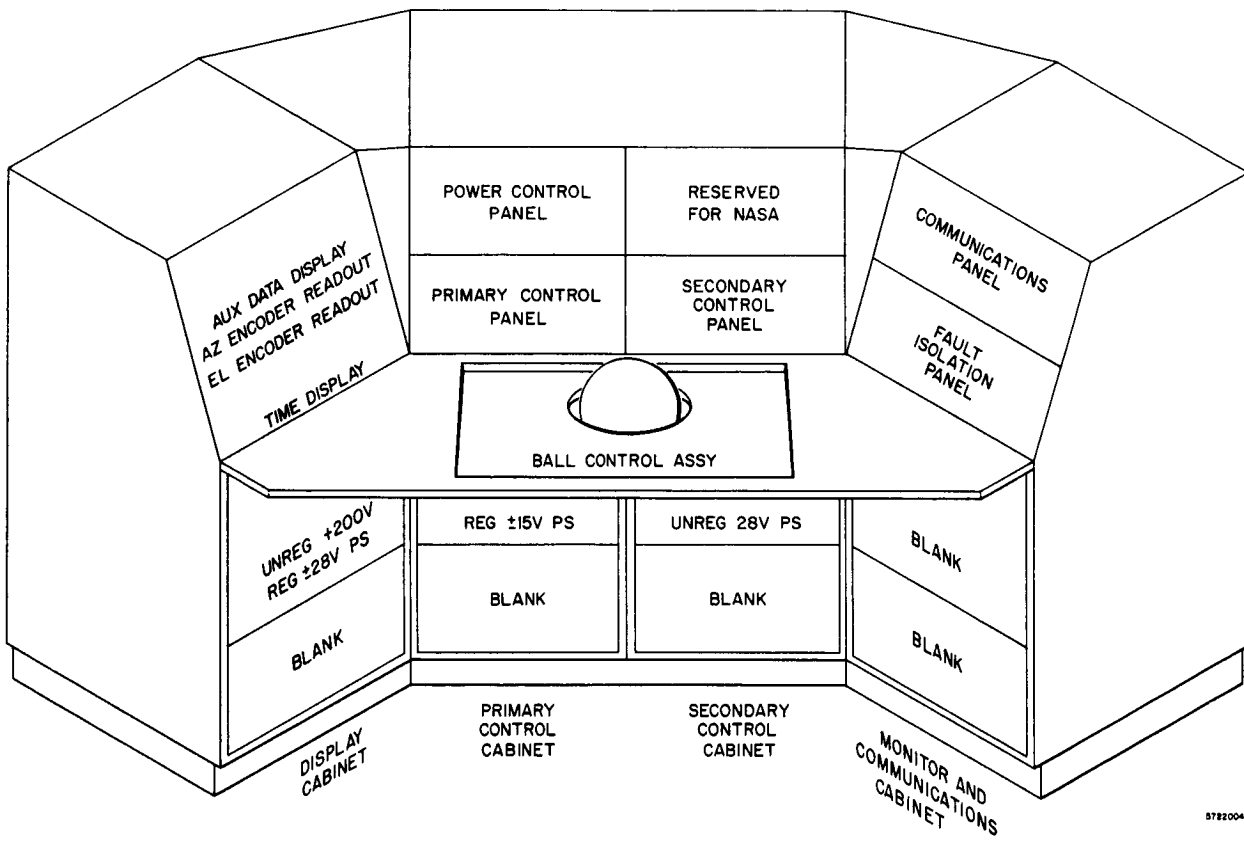

## UNIFIED S-BAND UPLINK

### INTRODUCTION

In earlier Manned Space Flight programs, several functionally independent systems using different frequency bands (HF, VHF & UHF) have been employed in the two-way spacecraft-ground links, resulting in highly complex facilities. However, in the Unified S-Band (USB) equipment for the Apollo program, most of the communicating functions have been integrated, for the first time, into a single comprehensive capability. All of the carrier frequencies in the two-way path are in the S-Band region (between 2100 and 2300 megacycles). Voice, television, telemetry data, range, range-rate, and antenna-tracking information may all be processed separately or simultaneously by the same radio frequency equipment.

Within the ground station facilities of the Manned Space Flight Network (MSFN), this unified concept is extremely evident in the receiver/exciter subsystem equipment. The subsystem acts as a link between the microwave equipment (such as the power amplifier and parametric amplifier) and the low-frequency RF, digital data processing, and DC actuated equipment. Information and reference signals from ten different external subsystems interface with the receiver/exciter equipment, which is in essence, a focal point in the USB concept. This equipment is also supplied, for most stations, in the dual configuration. This configuration contains two complete receiver/exciter subsystems for redundancy and multiple-vehicle operation.

The equipment discussed above includes the updata buffer modem, the sub-carrier oscillator subsystem and the verification receiver. Together, these items comprise a significant portion of the uplink communications system. The updata buffer modem accepts data from the command computer and operates on the data to put it into a form suitable for modulation onto a subcarrier. The subcarrier oscillator subsystem accepts data and voice signals and modulates these signals onto their respective subcarriers. The verification receiver samples the output of the S-Band power amplifier and demodulates the S-Band carrier. The output of the verification receiver is the original updata and upvoice signals. The data is returned to the buffer modem as an input to the command computer. The voice output is recorded.

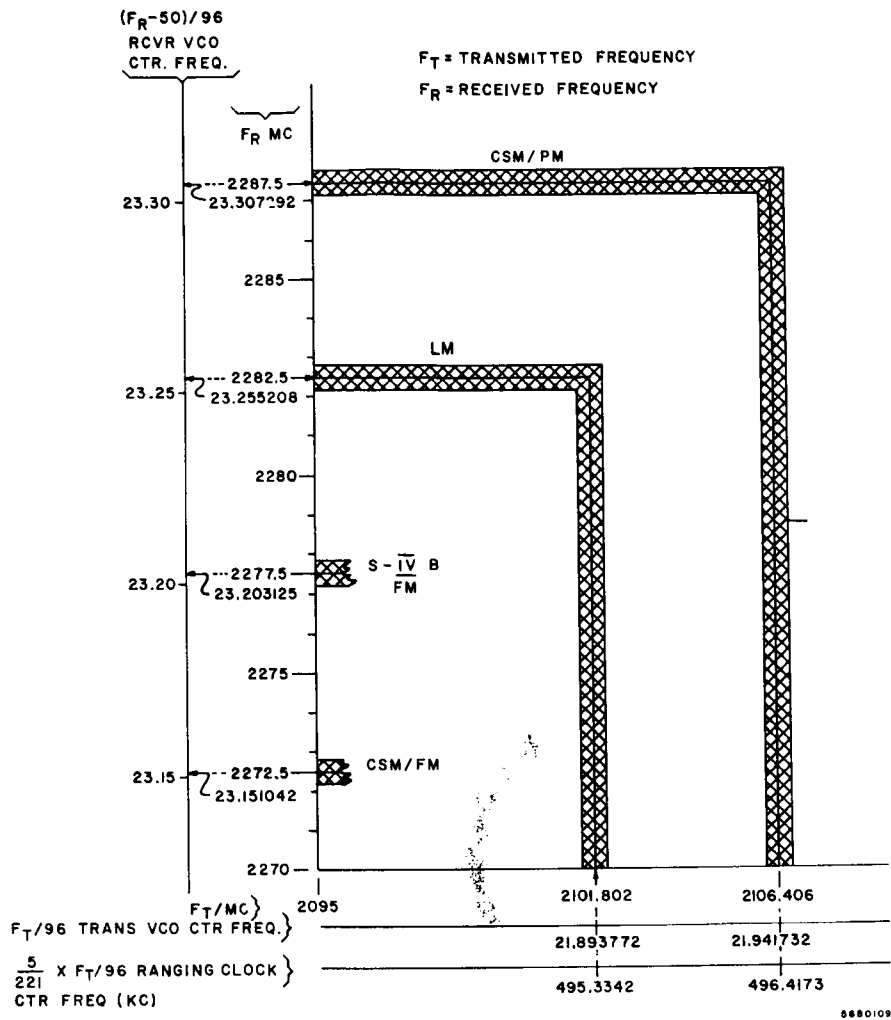

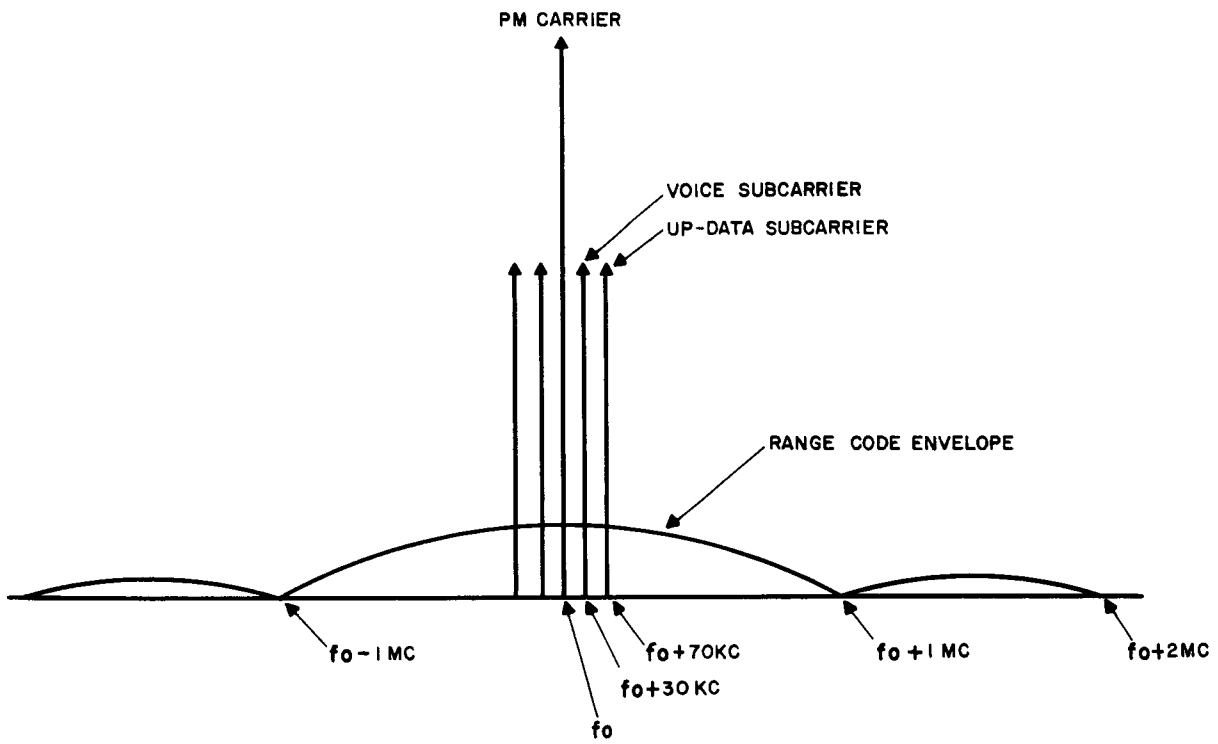

5880110

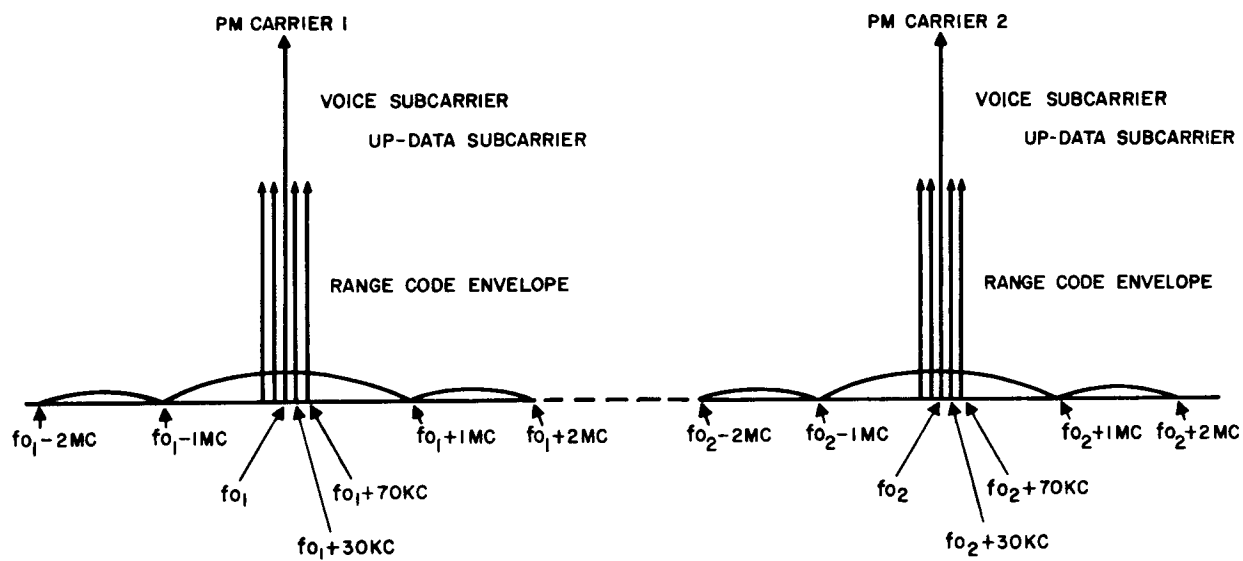

8880111



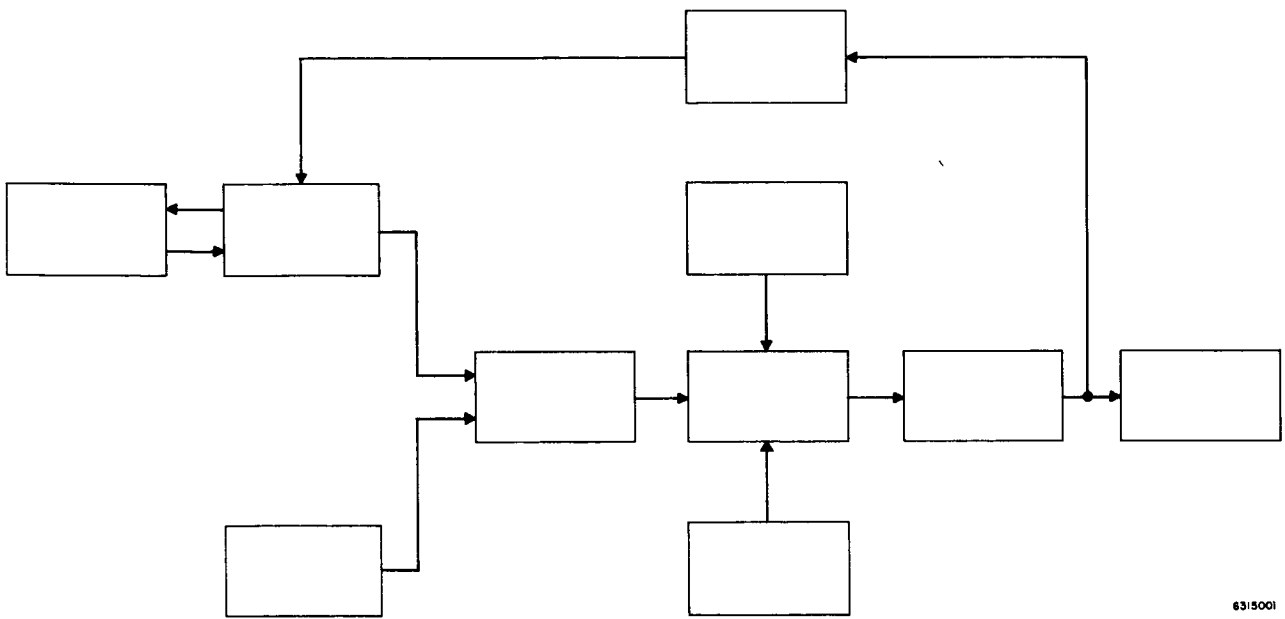

6315001

2-9

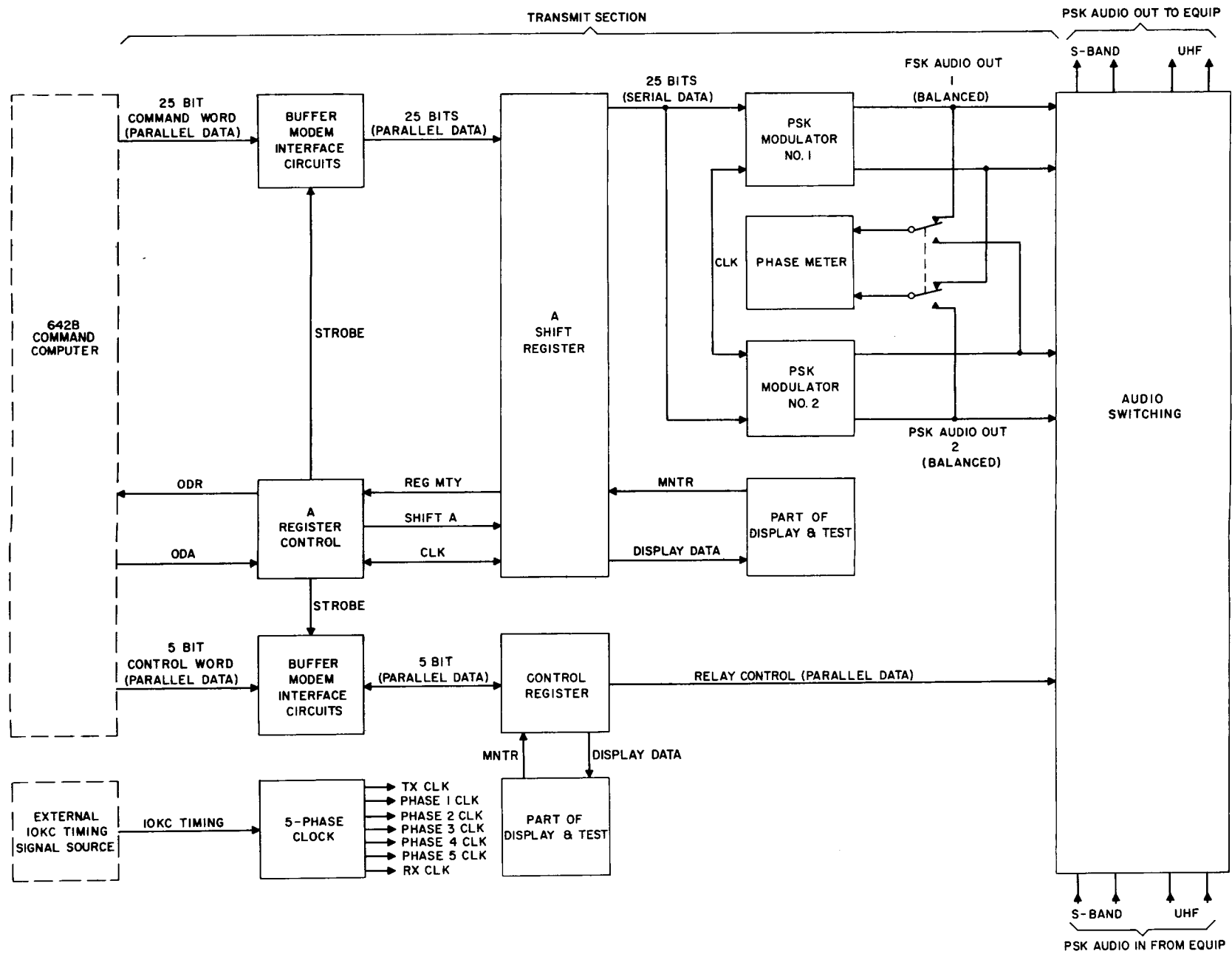

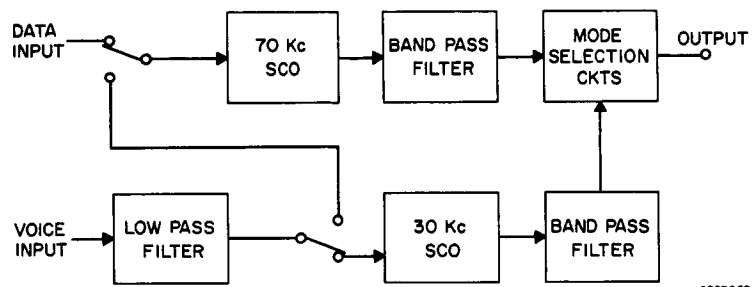

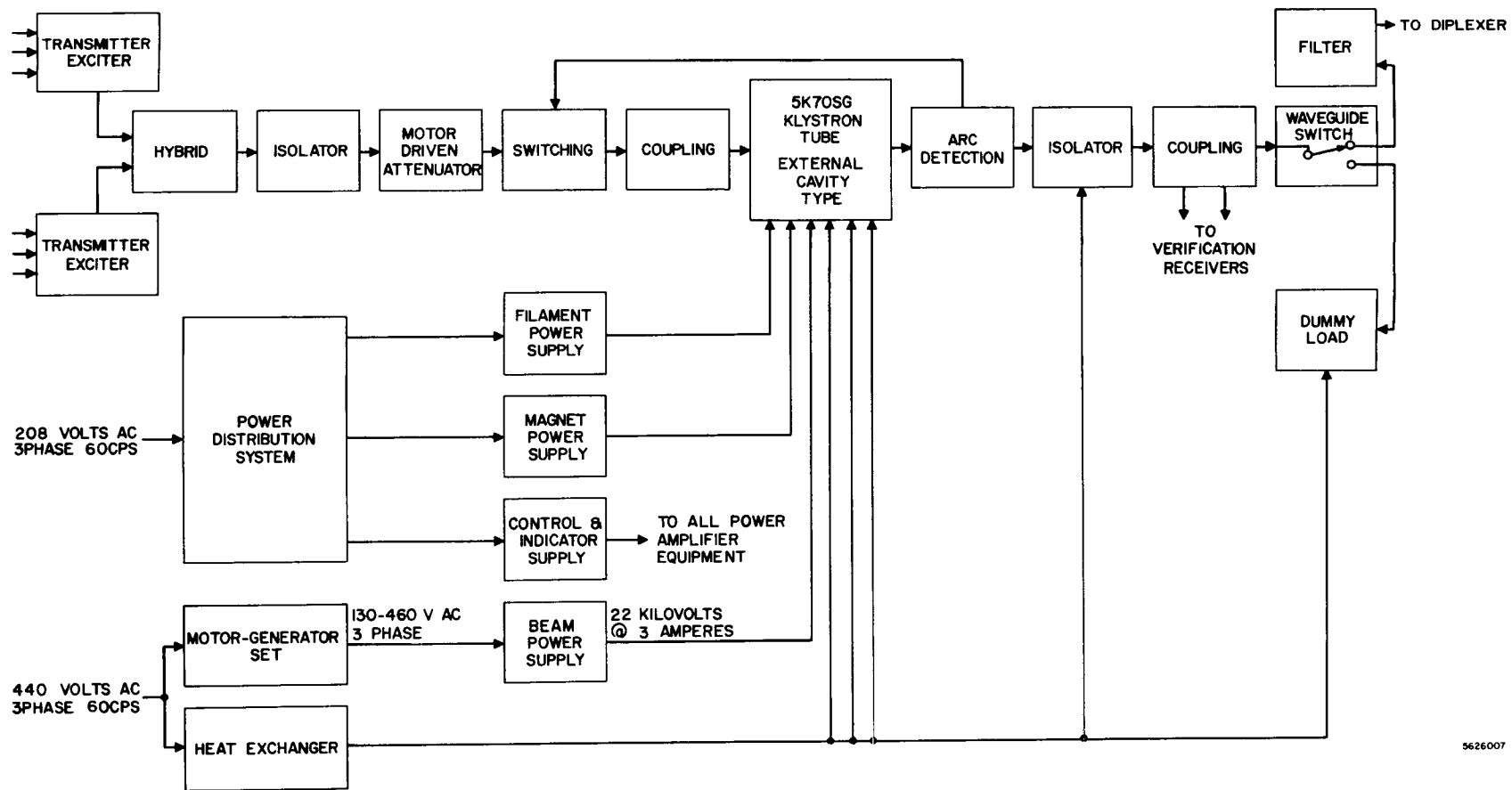

5626007

## GROUND SYSTEM CHARACTERISTICS

1. POWER AMPLIFIER - KLYSTRON  
Power output = 1-20 KW CW
2. PREAMPLIFIER - PARAMETRIC AMPLIFIER  
Gain = 20 DB  
Noise figure = 1.8 DB  
Bandwidth = 30 MC
3. CARRIER FREQUENCIES  
2106.4 MC command modules  
2101.8 MC LM or SIV-B
4. VOICE SUBCARRIER  
Frequency = 30 KC  
FM modulation = 100 CPS to 3 KC
5. UPDATA SUBCARRIER  
Frequency = 70 KC  
Modulation = 1 KC sync tone; 2 KC sine wave Bi-phase modulated at 200 CPS
6. RANGE CODE  
4 code generators driven at 1 MC bit rate  
The 4 C. G. outputs and 1 MC clock are added by digital logic in such a manner as to form a "maximum linear binary code"  
Length of short code =  $L_1$  -70 milliseconds  
Length of long code =  $L_2$  -5.4 seconds  
Unambiguous range of  $L_1$  = 7000 N. MI.  
Unambiguous range of  $L_2$  = 540,000 N. MI.

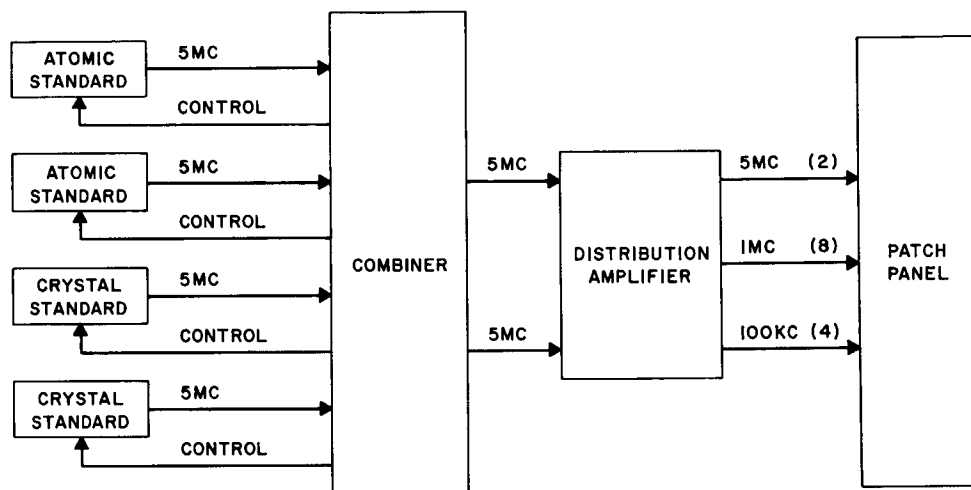

5762015

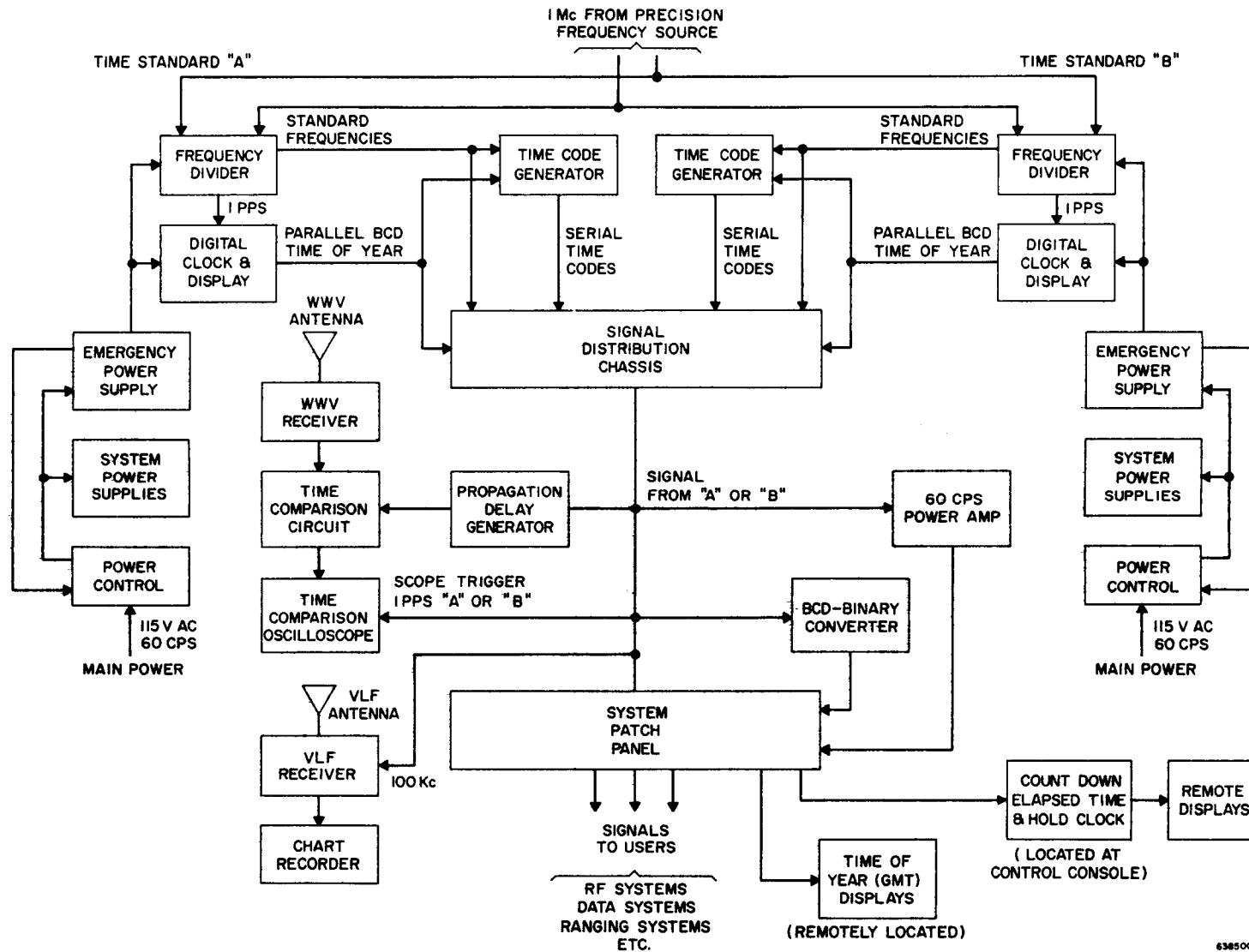

6385001

## UNIFIED S-BAND DOWNLINK

### INTRODUCTION

The spacecraft has the capability of transmitting two carriers simultaneously at different frequencies, one of these is phase modulated by the information and the other is reserved for frequency modulation. An examination of typical spectra of the phase and frequency modulated carriers reveals the necessity for simultaneous ground demodulation of both carriers and recovery of all data. Therefore ground stations with dual capability are equipped with two demodulator systems.

The signal data demodulator system is an integral part of the heart of the Unified S-Band system. The demodulator system is fed by the receiver and in turn feeds a multichannel tape recorder, provides the inputs to the various data display systems, and feeds the data processing equipment such as the PCM system. The receiver feeds the demodulators with two signals. One is a 50-megacycle IF which carries the frequency modulation. The other input from the receiver is at video and contains the phase modulation. Thus the signal data demodulator system consists of two channels which may be referred to as the FM and PM channels.

The 50-megacycle IF is routed to the carrier frequency demodulator which reduces the signal to video and feeds a recorder, an isolation amplifier and filter (television channel), the voice and biomedical data demodulator, and the telemetry demodulator. The PM video input from the receiver supplies the inputs to the voice and biomedical data subcarrier demodulator, the telemetry demodulator, and the emergency key demodulator. It should be noted at this point that the telemetry subcarrier demodulators and the voice and biomedical data subcarrier demodulators of the PM and FM channels are identical.

The outputs of the voice and biomedical data subcarrier demodulators and the telemetry subcarrier demodulators are routed to a data output selector, which is simply a switch. This allows the ground operators to route the voice, telemetry, and biomedical data to the proper data-processing equipment regardless of whether these data are recovered from the FM or PM channels of the signal data demodulators. In addition, the data selector provides the inputs to seven biomedical subcarrier demodulators for the recovery of the biomedical information.



The ranging code is routed from the receiver to the Mark I ranging system. The range rate or biased doppler is routed directly from the receiver to the Tracking Data Processor (TDP). Range is routed from the Mark I to the Tracking Data Processor. The output from the TDP is composed of range, range rate, time, and X and Y angles from the antenna servo system. The output from the PCM telemetry system is routed to the TLM computer for transmission to the Mission Control Center and/or display on the on-site consoles.

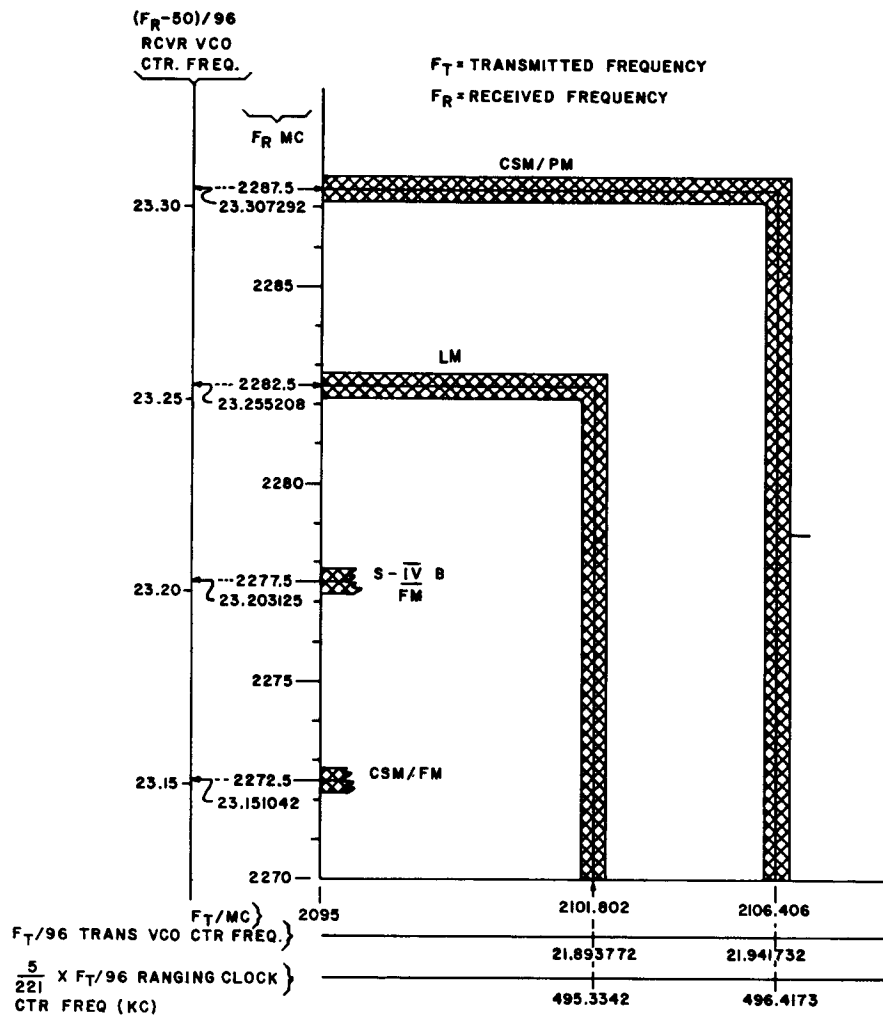

5880109

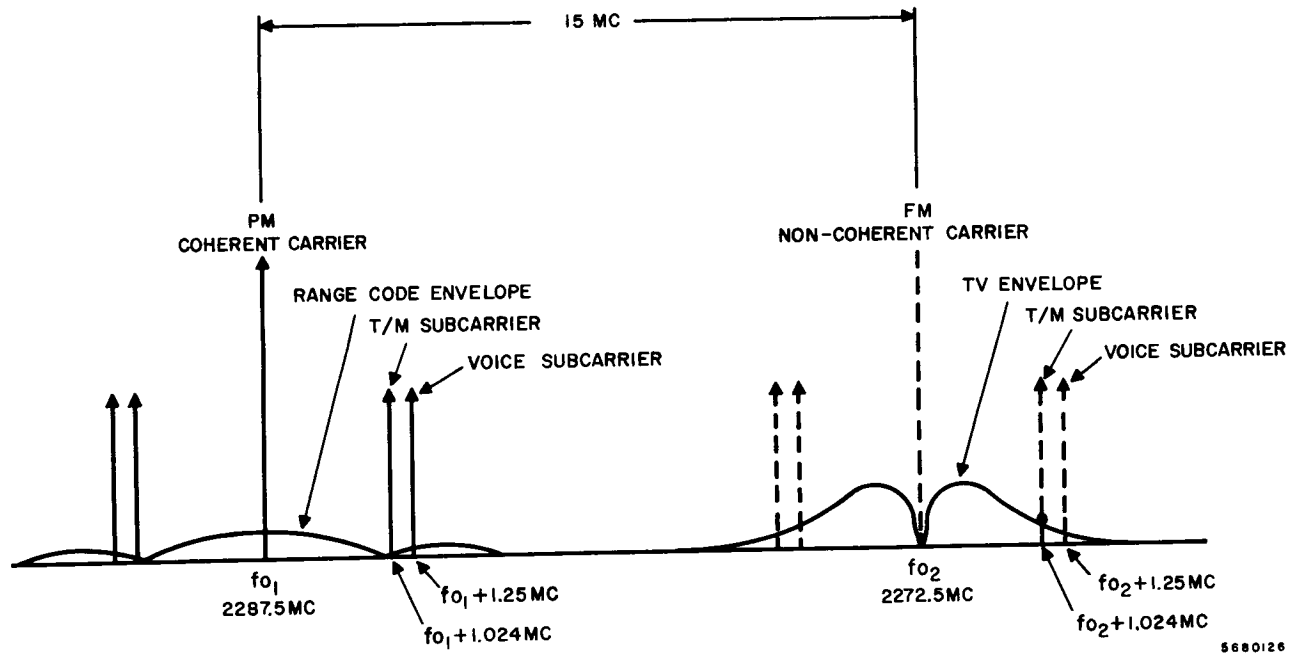

5680126

## FUNCTIONS OF S/C USB TRANSPONDER

1. Lock on to uplink carrier and track it as the frequency changes due to doppler effect.
2. Extract the uplink subcarrier modulation to produce voice and command information.
3. Detect binary ranging signal in a wide band phase detector and translate to a video signal.
4. Translate receive frequency by a factor of  $\frac{240}{221}$
5. Combine telemetry and voice subcarriers with ranging signal and the resultant modulates the PM downlink carrier.
6. Combine telemetry and voice subcarriers with television and the resultant modulates the FM carrier.

FUNCTION	REQUIREMENTS
Voice	Continuous Capability Normal - 90% Word Intelligibility Backup - 70% Word Intelligibility
Telemetry	Continuous Capability NRZ PCM at 51.2 KBPS or 1.6 KBPS rate
Ranging	Continuous Capability Phase Coherent Turn-Around of the PRN Range Code
Television	When Convenient Near-Commercial Quality Resolution and Gray Scale
Scientific Data Tape Playback	3 Channels Capability to Transmit Simultaneously with Real Time Data Telemetry, Voice, and Scientific Data
Emergency Key	Continuous Capability Maximum of 25 Characters per Minute
Relay Through CSM	EVA Voice and Biomed to MSFN LM Simplex Voice to MSFN

TRAINING USE ONLY  
 SEPTEMBER, 1966

SPACECRAFT TO GROUND  
 COMMUNICATIONS REQUIREMENTS

RRR-805  
 AI-052

2287.5 Mc Carrier Combination	Carrier Information	Modulation Technique	Subcarrier Frequency
1	Voice 51.2 KBPS Telemetry	FM/PM PCM/PM/PM	1.25 Mcs 1.024 Mcs
2	RPN Voice 51.2 KBPS TM	PM on Carrier FM/PM PCM/PM/PM	1.25 Mcs 1.024 Mcs
3	PRN Voice 1.6 KBPS TM	PM on Carrier FM/PM PCM/PM/PM	1.25 Mcs 1.024 Mcs
4	Voice 1.6 KBPS TM	FM/PM PCM/PM/PM	1.25 Mcs 1.024 Mcs
5	1.6 KBPS TM	PCM/PM/PM	1.024 Mcs
6	Key	AM/PM	512 Kcs
7	PRN	PM on Carrier	
8	Backup Voice 1.6 KBPS TM	PM on Carrier PCM/PM/PM	1.024 Mcs
9	PRN 1.6 KBPS TM	PM on Carrier PCM/PM/PM	

TRAINING USE ONLY  
MARCH, 1967

CSM TRANSMISSION COMBINATION  
SUMMARY (PM MODE)

RRR-806  
AI-053

2272.5 Mcs Carrier Combination	Carrier Information	Modulation Technique	Subcarrier Frequency
1	Playback Voice at 1:1 Playback CSM 51.2 KBPS TM at 1:1  Scientific Data Playback at 1:1	FM at Baseband  PCM/PM/PM  FM/FM FM/FM FM/FM	1.024 Mcs   95 Kcs 125 Kcs 165 Kcs
2	Playback Voice at 32:1 Playback CSM 1.6 KBPS TM at 32:1  Scientific Data Playback at 32:1	FM at Baseband  PCM/PM/PM  FM/FM FM/FM FM/FM	1.024 Mcs   95 Kcs 125 Kcs 165 Kcs
3	Playback LM 1.6 KBPS Split Phase TM at 32:1	FM at Baseband	
4	Television	FM at Baseband	
5	Real Time Scientific Data	FM/FM FM/FM FM/FM	95 Kcs 125 Kcs 165 Kcs

TRAINING USE ONLY  
MARCH, 1967

CSM TRANSMISSION COMBINATION  
SUMMARY (FM MODES)

RRR-807  
AI-054

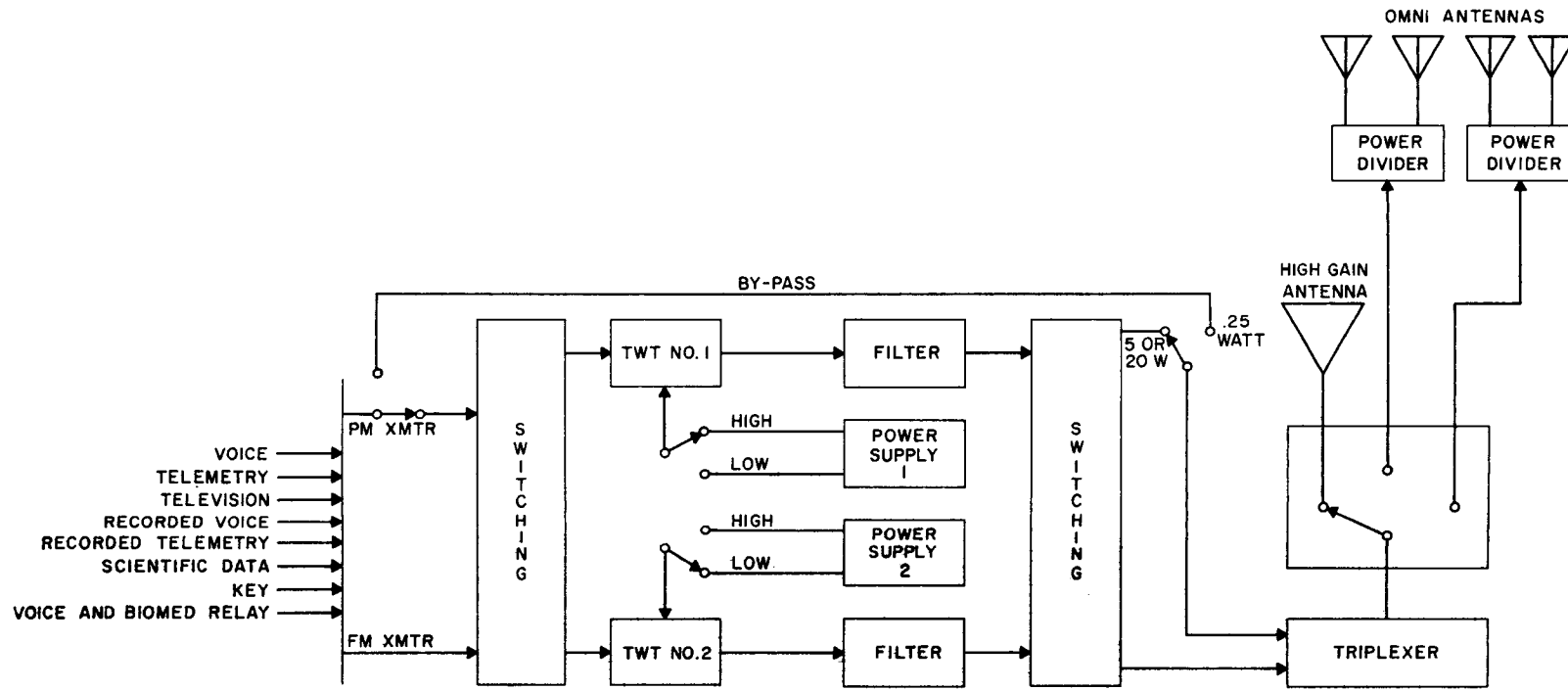

6315002



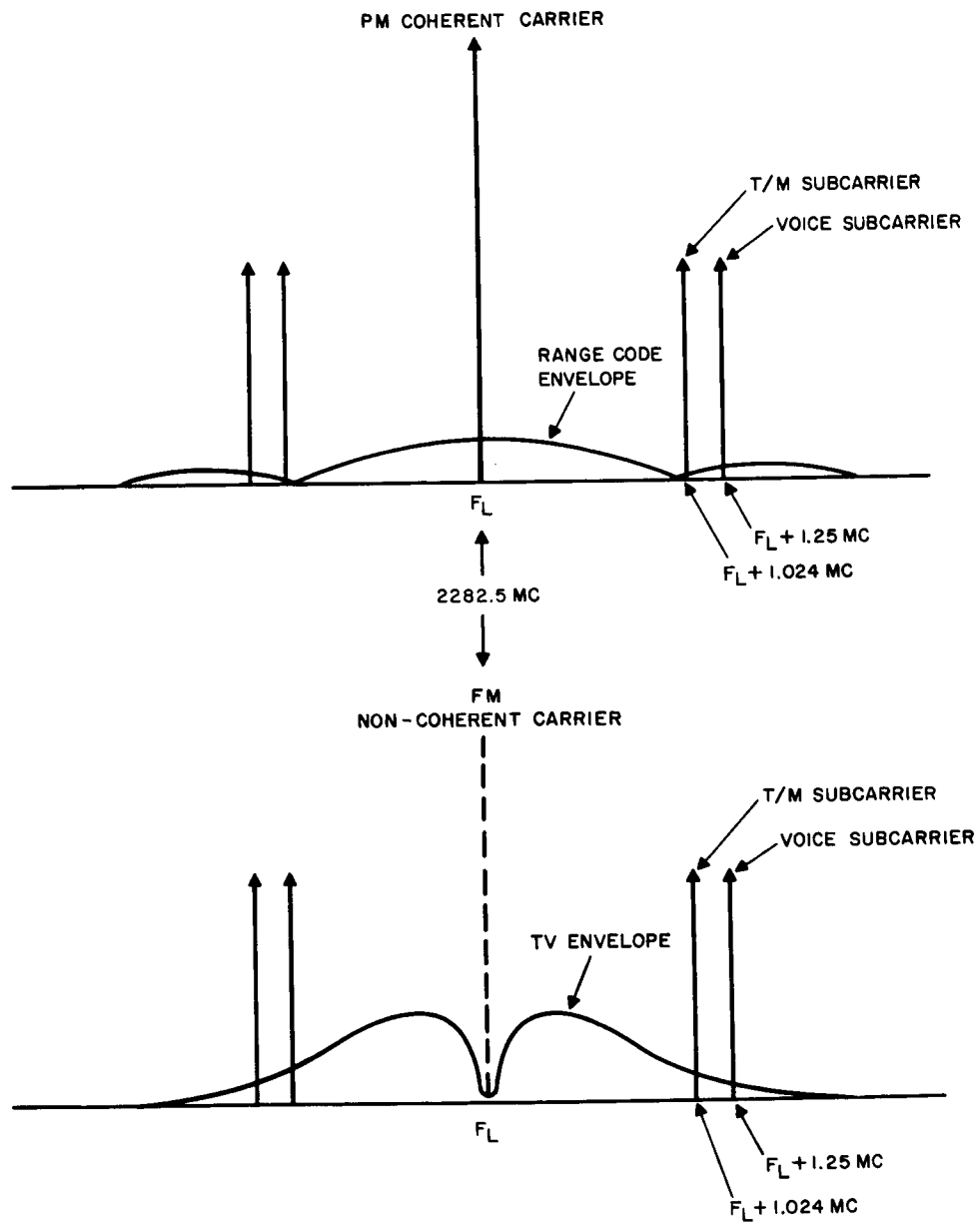

5580127

2282.5 Mcs Carrier Combination	Carrier Information	Modulation Technique	Subcarrier Frequency	Carrier Phase Deviation
1	Voice 51.2 KBPS TM	FM/PM PCM/PM/PM	1.25 Mcs 1.024 Mcs	0.7 Radians 1.3 Radians
2	PRN Voice 51.2 KBPS TM	PM on Carrier FM/PM PCM/PM/PM	1.25 Mcs 1.024 Mcs	0.2 Radians 0.7 Radians 1.3 Radians
3	1.6 KBPS TM	PCM/PM/PM	1.024 Mcs	1.3 Radians
4	Backup Voice 1.6 KBPS TM	PM on Carrier PCM/PM/PM	1.024 Mcs	0.8 Radians 1.3 Radians
5	Backup Voice	PM (24 db Clipping)		0.8 Radians
6	Carrier Key	AM/PM	512 Kcs	1.4 Radians
7 Lunar stay Mode	Voice/Biomed 1.6 KBPS TM	FM/PM PCM/PM/PM	1.25 Mcs 1.024 Mcs	1.3 Radians 0.7 Radians
8	Voice/EMU/ Biomed 51.2 KBPS TM	PM on Carrier (No Clipping) PCM/PM/PM		TBD  Carrier Deviation Ratio
9	Voice/EMU/ Biomed TM	FM/FM  PCM/PM/PM	1.25 Mcs  1.024 Mcs	0.17  0.37
10	TV Voice/EMU/Biomed 1.6 or 51.2 KBPS Telemetry	FM on Baseband FM/FM/FM PCM/PM/PM	1.25 Mcs 1.025 Mcs	2.0 0.17 0.37

TRAINING USE ONLY  
MARCH, 1967

LM TRANSMISSION  
COMBINATION SUMMARY-

RRR-810  
AI-056

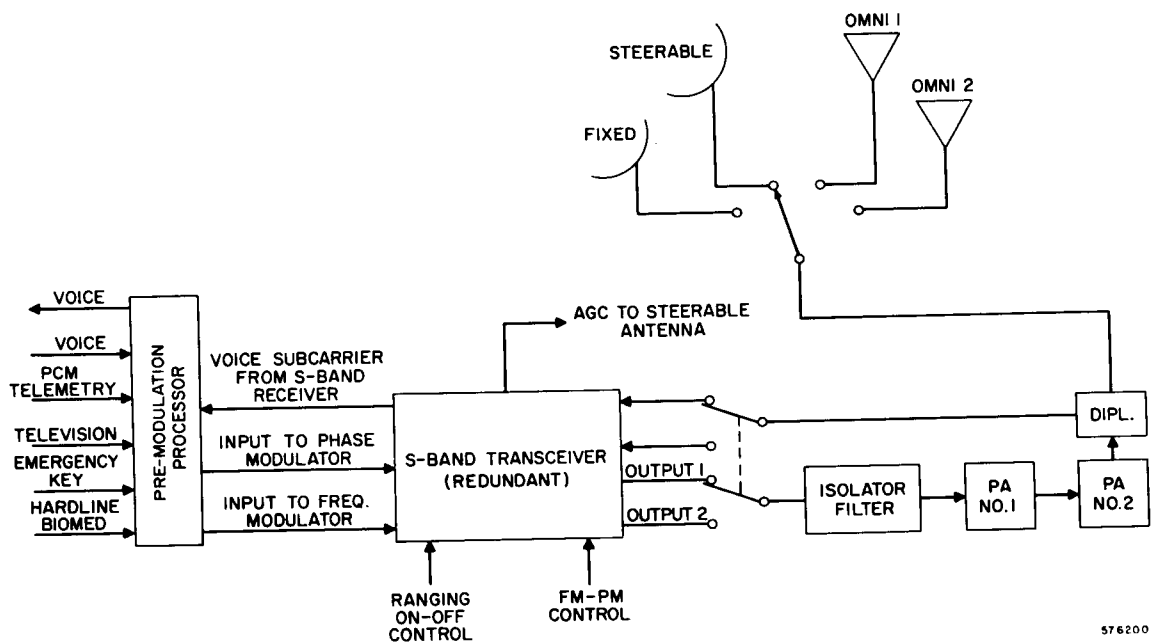

5762001

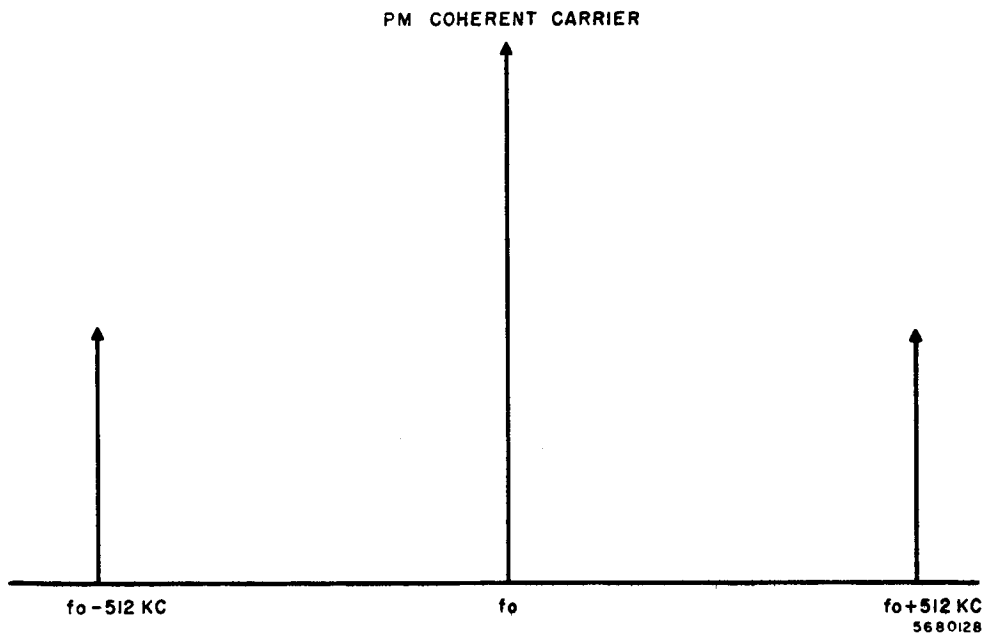

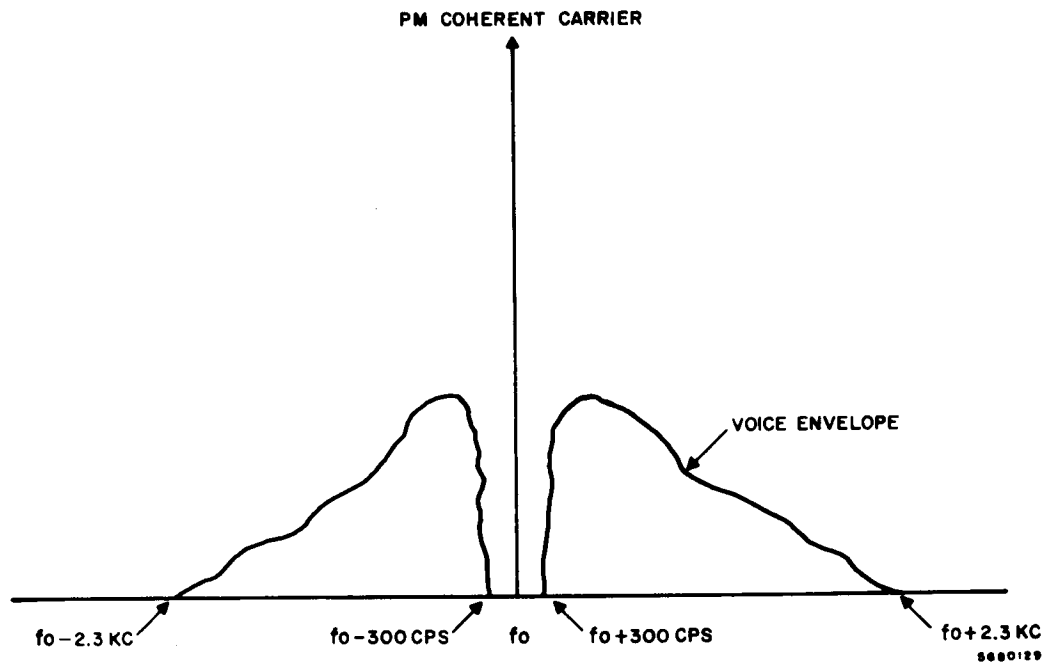

## SPACECRAFT USB CHARACTERISTICS

1. POWER AMPLIFIER - TWT  
Power output - 20, 10 or 5 watts
2. ANTENNAS  
Omnidirectional (near earth thru transposition)  
High gain (28 DB) (after transposition and lunar)
3. CARRIER FREQUENCIES:  
2287.5 MC-command module PM carrier  
2272.5 MC-command module FM carrier  
2282.5 MC-LM or SIV-B PM carrier  
2277.5 MC-SIV-B FM telemetry carrier  
2282.5 MC-can also be used in FM mode from LM  
Note:  
All PM spacecraft carriers are  $\frac{240}{221}$  x ground PM carrier
4. VOICE SUBCARRIER-1.24 MC  
Modulation-300 to 2300 CPS voice +7 channels of biomedical data
5. TELEMETRY SUBCARRIER-1.024 MC  
Bi-phase modulated at 51.2 KBPS-high data rate  
1.6 KBPS-low data rate
6. FM TELEVISION  
500 KC modulation  
320 lines  
10 frames/sec
7. EMERGENCY KEY  
512 KC subcarrier manually keyed and modulated directly on carrier.

METHOD OF ACHIEVING 2-WAY LOCK  
BETWEEN SPACECRAFT AND GROUND STATION

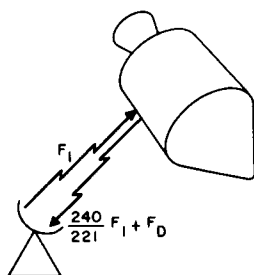

1. CARRIER WITHOUT RANGE CODE TRANSMITTED TO SPACECRAFT.
2. NARROW BAND PHASE LOCK LOOP IN SPACECRAFT TRANSPONDER LOCKS TO GROUND CARRIER FREQUENCY.
3. AFTER TRANSPONDER LOCKS TO GROUND FREQUENCY; THE SPACECRAFT TRANSMITS THE FREQUENCY  $\frac{240}{221} F_i$
4. MAIN CARRIER TRACKING LOOP IN GROUND STATION LOCKS TO S/C FREQUENCY ACHIEVING 2-WAY COHERENT LOCK.
5. UPON COMPLETION OF 2-WAY LOCK, THE UPLINK AND DOWNLINK CAN BE FULLY MODULATED.

5590002

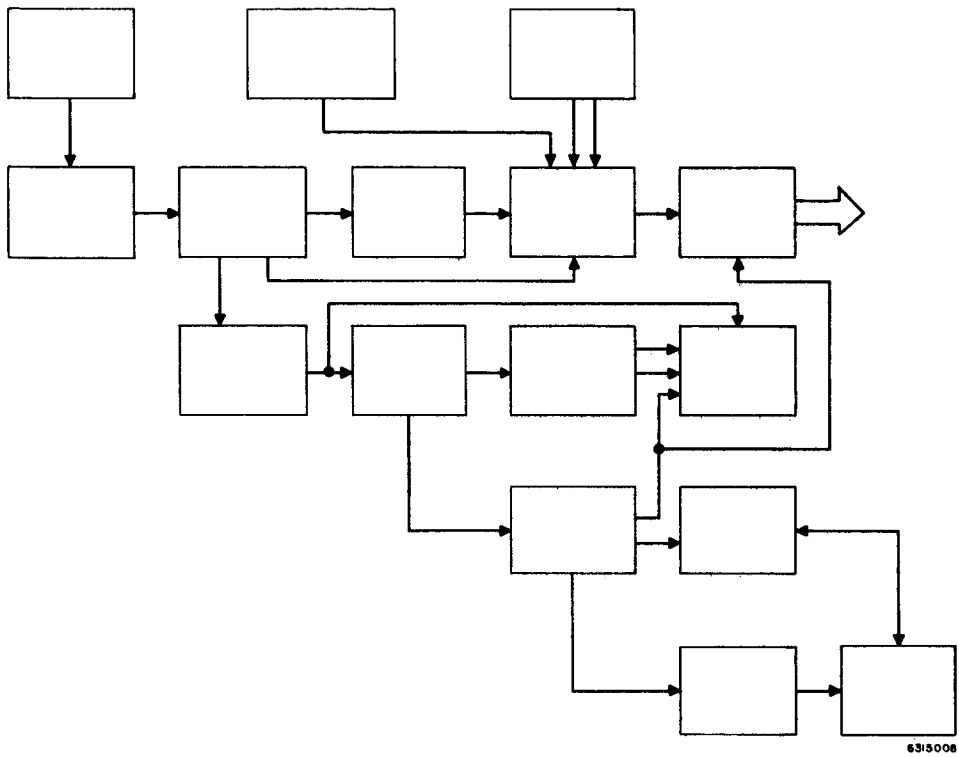

6315008



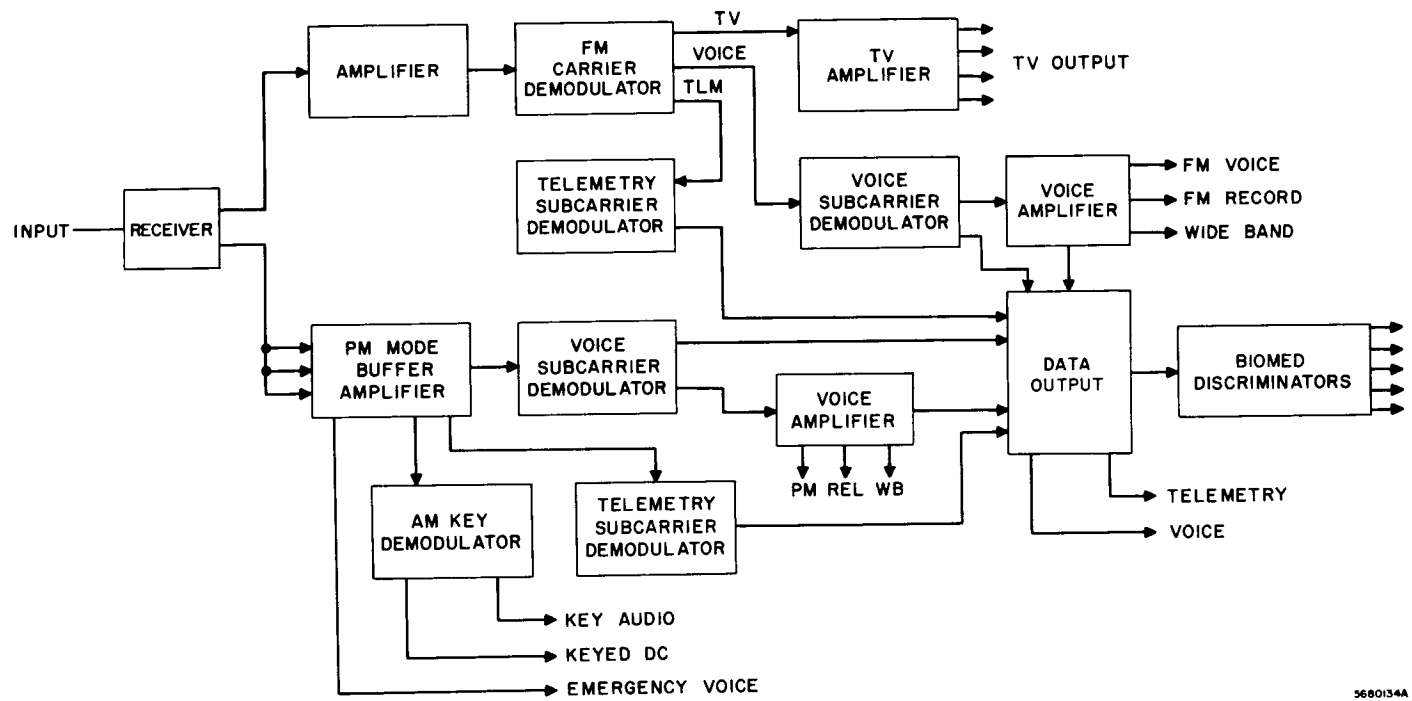

5680134A

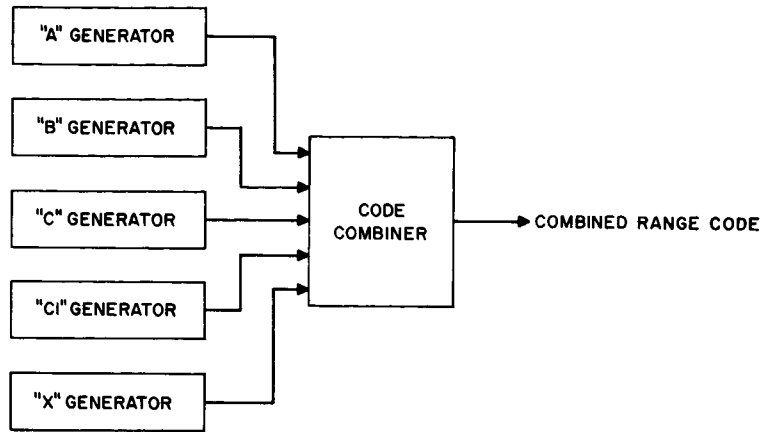

56808

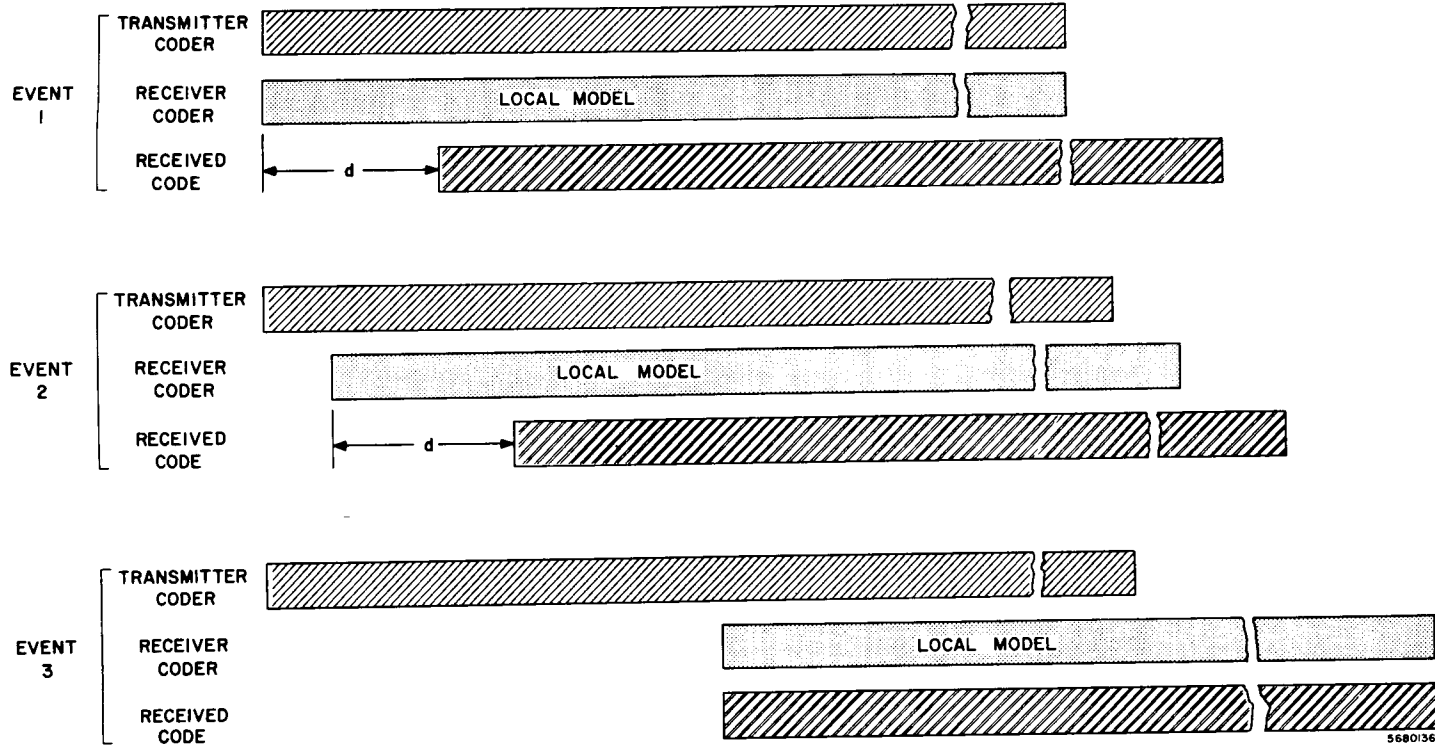
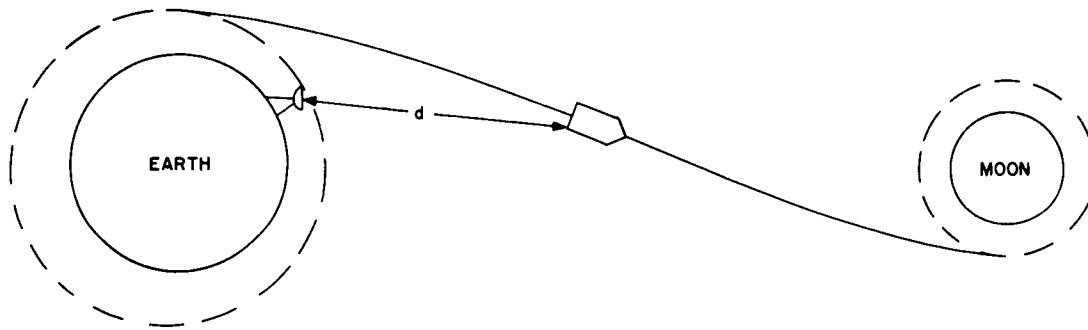

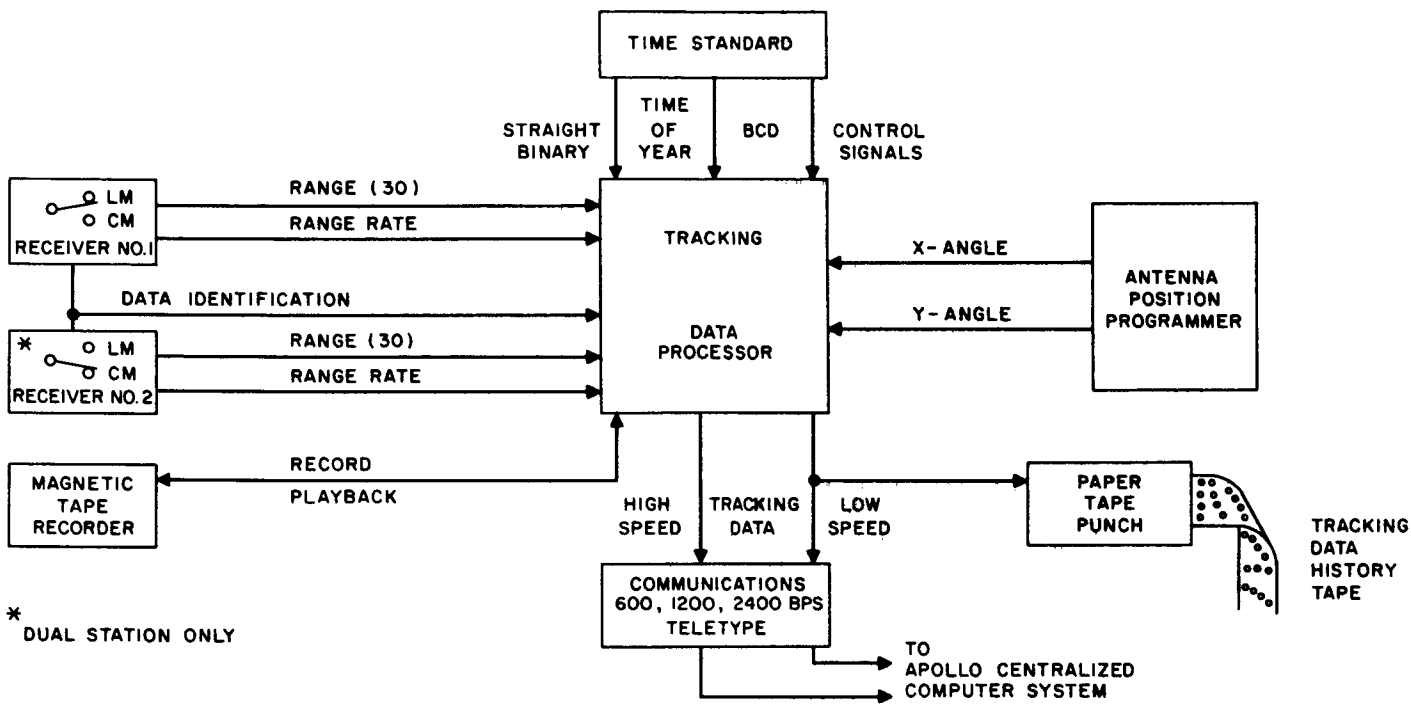

6315023

6-22

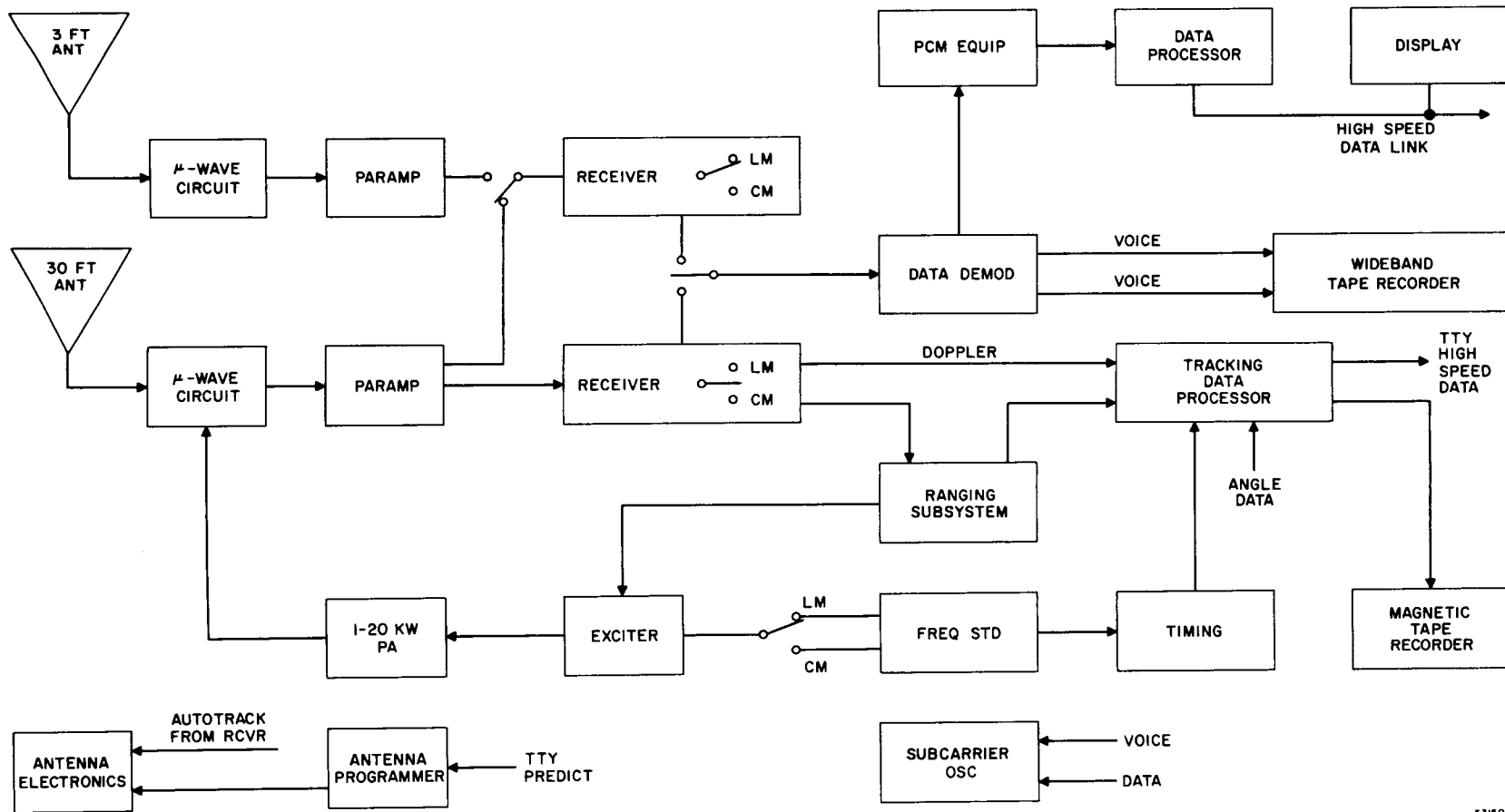

6315018

6-23

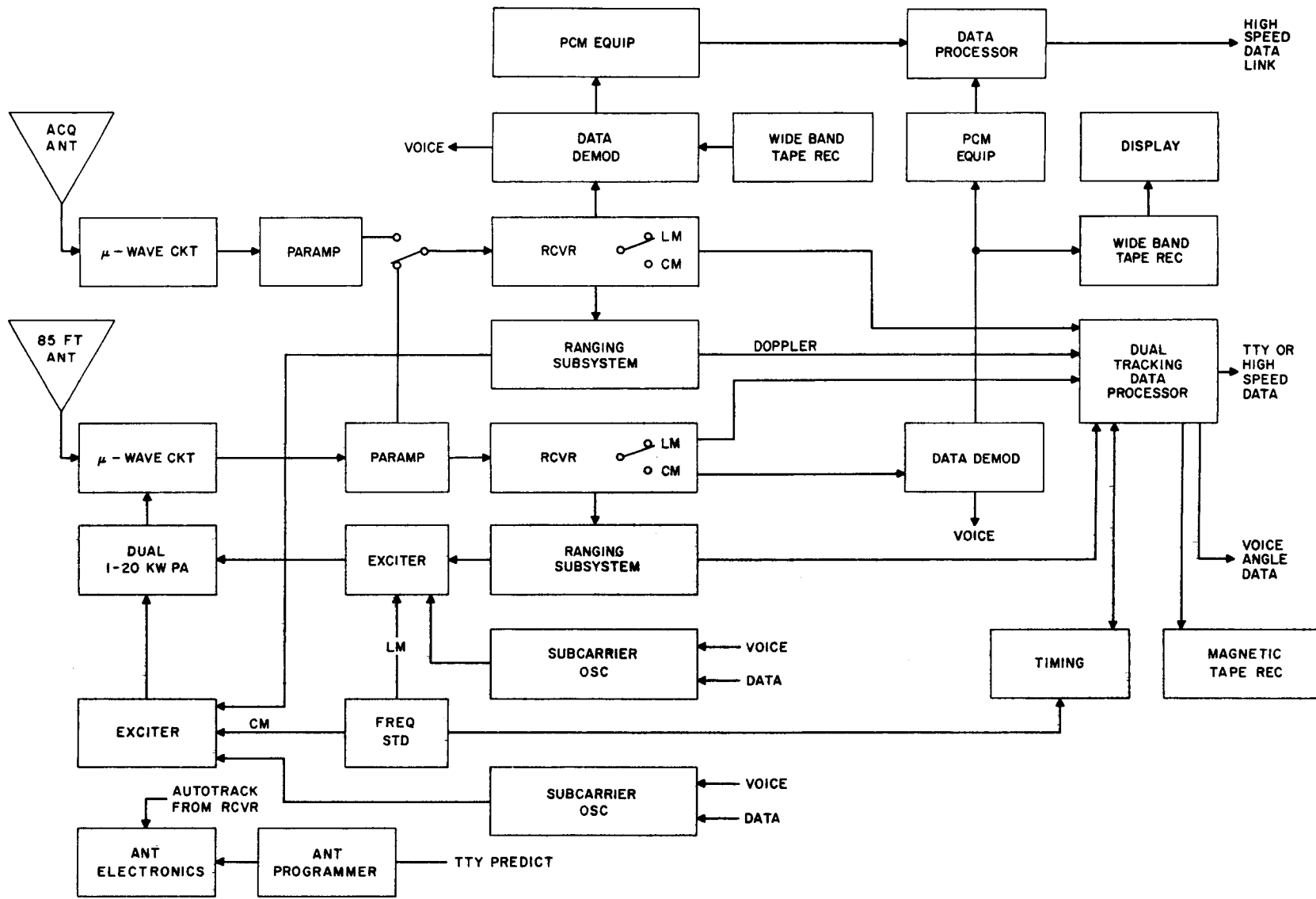

6385017

6-24

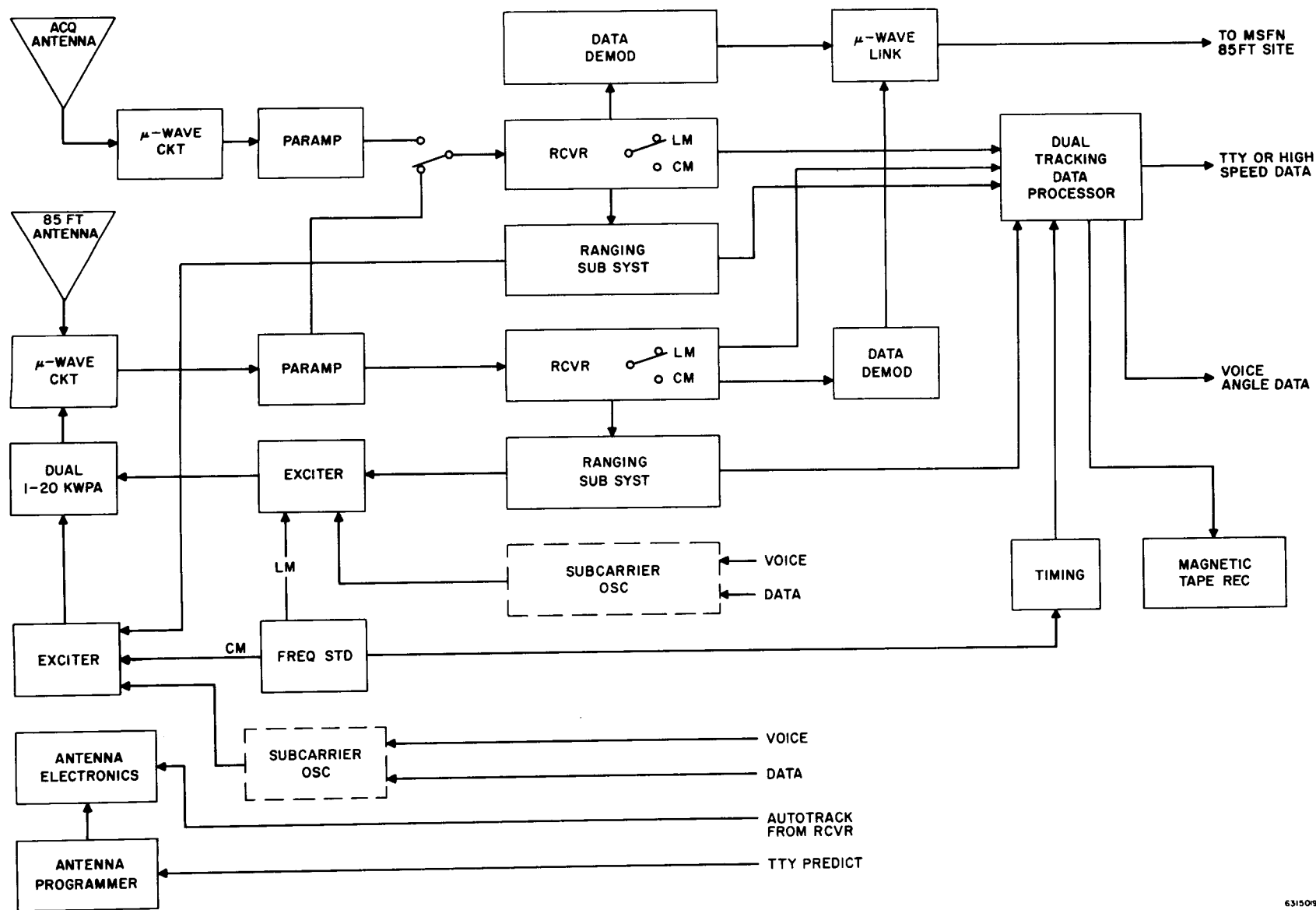

631509

## APOLLO DIGITAL COMMAND SYSTEM

### INTRODUCTION

The purpose of the Apollo Digital Command System (DCS) is to provide a means for communicating with and controlling the spacecraft's equipment from the ground. Some commands are identified before the launch; others are developed by the computing complex, Command, Computer and Telemetry System (CCATS), at the Mission Control Center (MCC) in Houston during the mission.

The commands identified before the mission are the type that are to be executed at selected intervals during the mission. One of these commands may be sent several times from one or more ground stations. For example, a command requesting a tape playback of spacecraft recorded data may be sent by all stations once or twice during a mission.

Other commands developed during the mission by the MCC computers would ordinarily be sent only once by one station. However, if the transmission were not successfully accomplished by the selected station, it would be retransmitted by another station later during the mission. An example would be the correct time for the spacecraft computer. The time of the spacecraft computer is telemetered to the ground stations. If this parameter does not agree with the indicated ground time, a command will be sent to the spacecraft computer that will update the timing system with the correct time.

Two types of digital commands will be utilized in the Apollo program; Real Time Commands (RTC) and Stored Program Commands (SPC). Real Time Commands are those generated during a mission by MCC and transmitted to a remote station for immediate transmission to the spacecraft. Stored Program Commands are those that are known before a mission; therefore, generated and transmitted to the remote station and stored in the 642B command computer prior to launch. These commands may be called up and executed during a mission either by the MCC or the on-site Flight Controllers.

A command word is configured so that each command will only be accepted by the selected spacecraft if it has the correct vehicle address, systems address, bit structure, and word length. The vehicle address requirement is obvious. The system



address is required to differentiate between the Real Time Computer (RTC), Apollo Guidance Navigational Computer (AGC), and the Central Timing Equipment (CTE) systems aboard the vehicle. The bit structure employs sub-bit coding for security measures.

The philosophy for secure updata transmission is to insure that the command word will be rejected by the spacecraft if it is not the exact command word transmitted. Measures have been taken in all phases of the updata transmission system to insure that the chances of the spacecraft accepting an invalid command is  $1 \times 10^{-9}$ . In the ground-to-air link each information bit is encoded into five sub-bits to insure the nonvalid command rejection ratios.

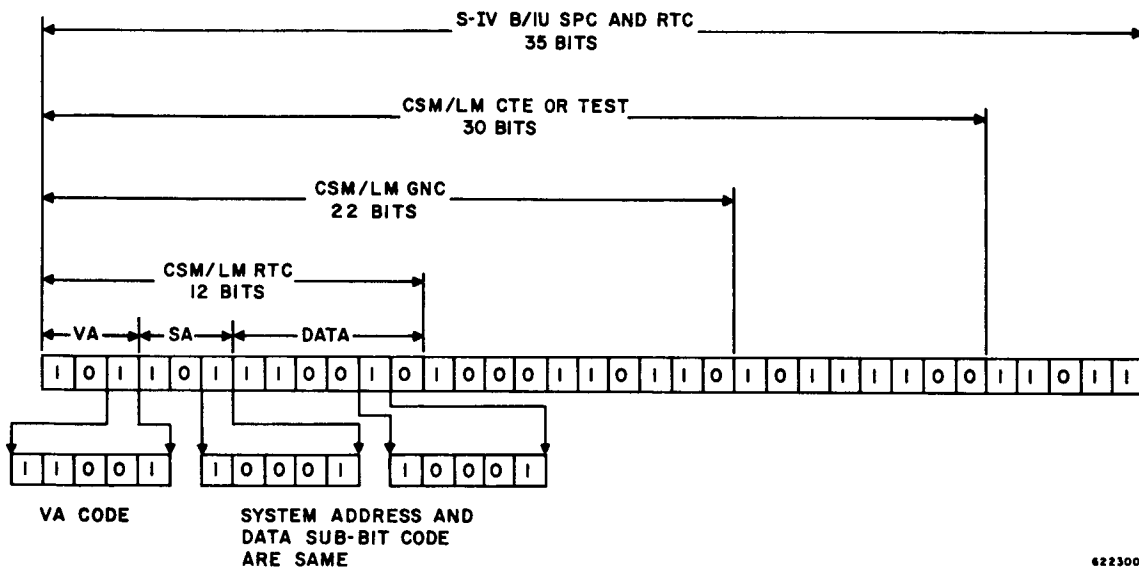

6223001

7-4

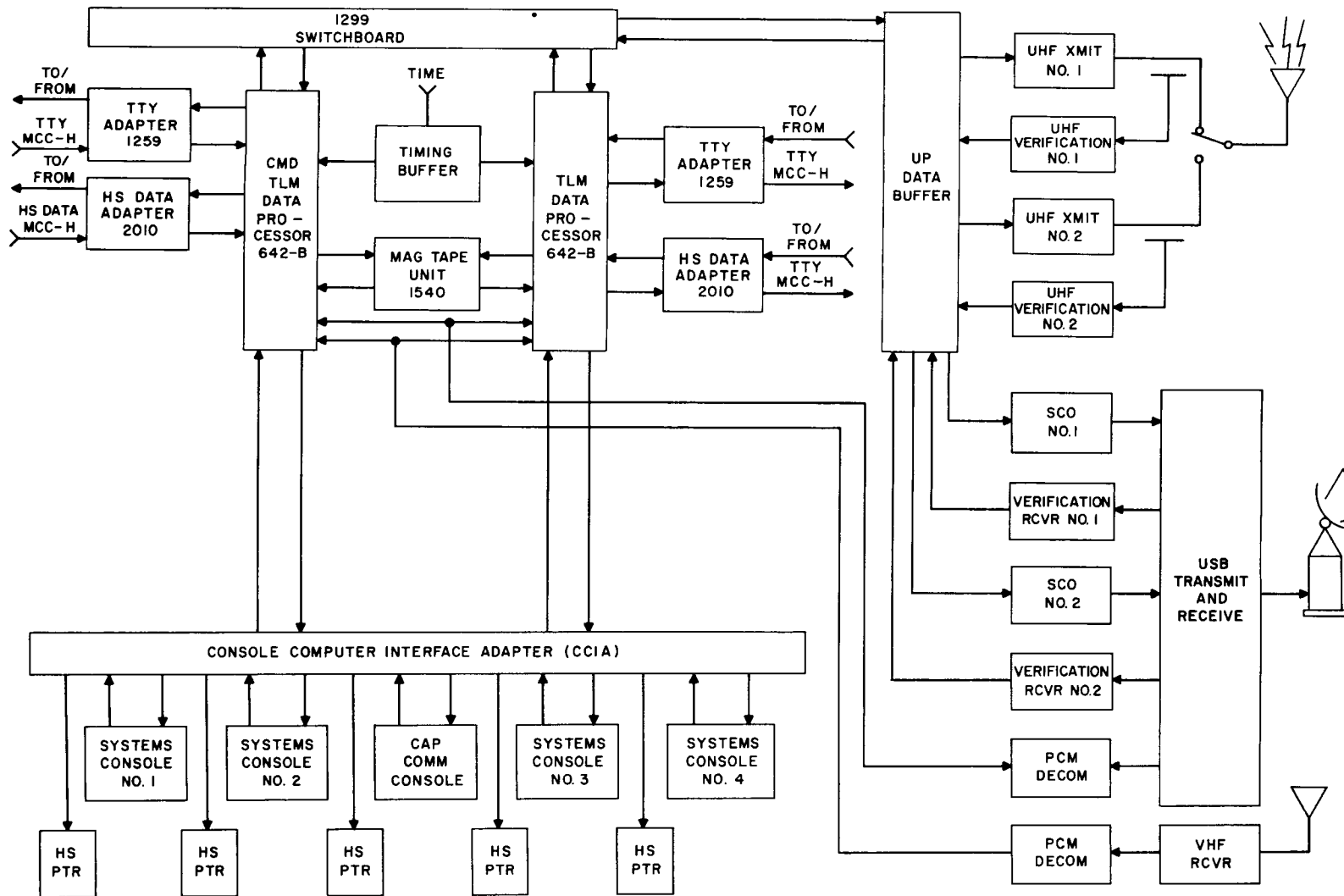

6315009

7-5

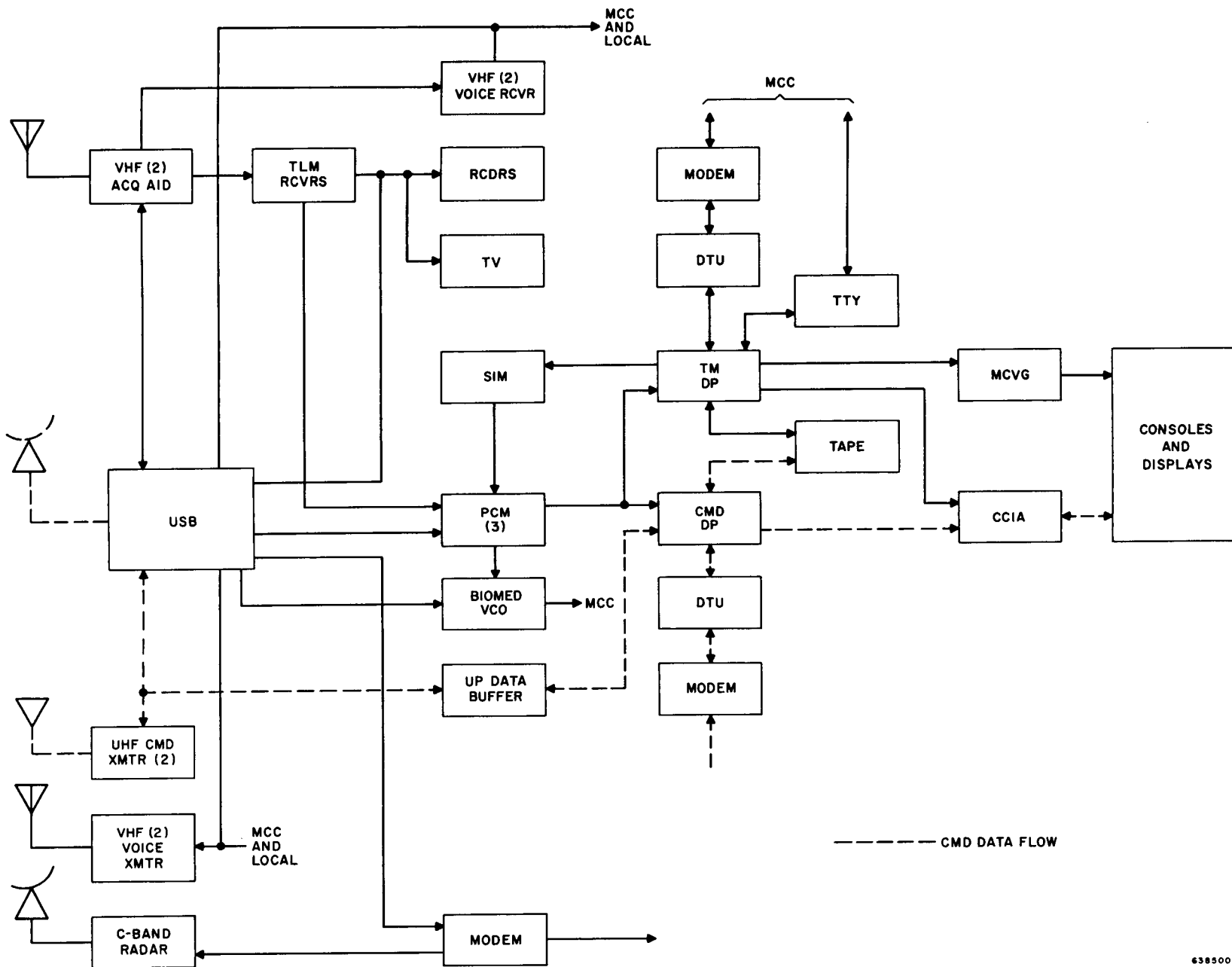

6385003

CP-642B COMPUTER  
COMPUTER CHARACTERISTICS

I. DESCRIPTION

This information sheet will give the student an introduction to the characteristics of the CP-642B computer. Computer concepts, power requirements, different voltage levels used throughout the computer, memory characteristics, special I/O modes and quick reference tables are included.

II. INSTRUCTIONS

A. General Information

The CP-642B computer is a general purpose, stored-program machine capable of processing large quantities of complex data where heavy input/output communication is required. The basic word length is 30 bits and the machine has a single address instruction word. It is equipped with a 2 microsecond main memory and a 400 nanosecond control memory. Proper programming will give an effective 1 microsecond main memory cycle time.

The computer can perform mathematical operations, control other equipment, provide communication and navigational assistance, solve problems in real time, or perform data processing. The computer communicates with peripheral equipment and other computers via its 16 input and 16 output channels. The timing sequence permits data to be transferred at a maximum rate of 500,000 input/output words per second.

B. Computer Concepts

The computer must be manually initiated, but thereafter (for a given function or operation) operation may be automatic. Computer operations for a given function are initiated, controlled, and terminated by the program stored in the computer's memory section. This program contains instructions, constants, decision-making capabilities, and an input/output capability. The instructions initiate and control specific operations.

The decision-making capability is accomplished by certain instructions which compare quantities with each other or constants, or which make real time decisions. The instructions of a program are usually stored in memory in sequential addresses. They are performed in a sequential order unless a program decision causes some instructions to be skipped. The program is terminated when a predetermined event or conclusion is reached or all the instructions have been performed.

Programs are usually entered into the computer via an input device such as a punched tape reader or a magnetic tape unit. The outputs from the computer may be via the punched tape unit, a monitoring typewriter, or by a number of other peripheral devices. The input or output buffer may be manually initiated, but the actual buffer operation is under computer control.

An instruction is generally performed in four basic steps:

- Step 1. Obtain the instruction.
- Step 2. Obtain data (operand).
- Step 3. Do the operation specified.
- Step 4. Process the result.

These operations are under the control of the major timing sequences and sequence designator in the computer.

Since the instructions of a program are stored in the memory section, the first step in obtaining the instruction is to determine which memory address to reference. During the initiation of a program, the first address is manually entered into the computer; succeeding memory addresses are referenced in sequentially, or other wise, depending upon program controls and preliminary results. After the instruction word has been obtained, the data to be manipulated (operand) must be obtained. This operand can come from an addressable register or from a memory address specified by the instruction word. A portion of the instruction word specified whether the operand length is 15 or 30 bits.

After the instruction word and operand have been obtained, the operation specified by the instruction word is performed. This may be a relatively

simple and fast instruction such as an add or subtract or it may be a longer, more complicated instruction such as a multiply or square root. After the operations specified by the instruction are completed, but before the result is operated on, another operation may take place. This operation is a decision affecting the next instruction of the program. If a condition (specified by a designator of the instruction word) exists, the next instruction of the program will be skipped. If this specified condition does not exist, the next instruction is performed in the usual manner. This designator may also be such that a skip is performed or not performed, regardless of other conditions. This skip/no skip condition can be made for most instructions. There are also instructions whose function is to provide a program branch (the exit from one routine to another). A jump instruction is normally used to achieve a program branch. If satisfied, it causes a new routine to be entered. The first address of the new routine is specified by the jump instruction word. This new routine may contain program branches to other routines and/or a return jump to the original routine. Certain conditions specified by the jump instruction word must exist before the jump is made. For example, Jump if (A) is positive: if the content of the A register is a positive quantity, the jump to the specified address is performed; if the content of the A register is not positive, the jump is not made, and the next sequential instruction of this routine is performed. These jump conditions may be dependent upon the contents of various computer registers or Input/Output channels or upon selection of one or more switches on the console.

With these jump instructions and skip/no skip conditions, decisions can be made at critical points in a program, and new routine may be started if the desired results have already been obtained.

The various programs and subroutines also contribute towards effective computer operation. A subroutine is a smaller program written to perform a specific task; it is usually entered from and exits to a larger routine. These subroutines increase the problem-solving capability of the computer. For example, a subroutine for finding the cube root subroutine and then return to the main routine with the result. The main program may process this result and at some other time jump to another subroutine for another function.

Input to or output from the computer may be initiated in two ways: program initiation or external equipment requests (external interrupts only). There are specific instructions in initiate input or output buffers on specified Input/Output channels. The length of the buffer (number of words transferred) is specified by the instruction word, or the buffer may be terminated by another instruction. When external equipment desires communication with the computer, it activates a signal line to the computer which specifies whether the desired buffer is input or output. (When discussing computer communication, input is input to the computer and output is output from the computer.) When the computer has accepted or furnished the requested data, it sets an acknowledge line that indicates, to the external equipment, that the desired communication is completed. The external equipment can initiate one word buffers only; that is, the request to the computer must be issued for each word to be transferred. When operation has been manually initiated in the desired routine, computer operations are automatic until the routine is terminated or manual intervention causes some other operation. Routines and subroutines are used to perform the computer's data processing functions and to assist in the checkout and maintenance of the computer.

### C. Internal Features

#### 1. Main Memory

- a. Ferrite core main memory.
- b. 32,768 thirty bit words in 2 banks, separately accessible. This memory can be expanded to 131,027 thirty bit words without modification.
- c. 2 microseconds cycle time, 1 microsecond effective cycle time with overlap of 2 banks.

#### 2. Control Memory

- a. 128 or 256 thirty bit words.
- b. 400 nanoseconds read/write cycle time.



- c. Control memory is used for index registers, I/O access control, and auxiliary storage.
3. Bootstrap Memory
- a. Nondestructive readout.
  - b. 2 microseconds cycle time.
  - c. Bootstrap memory is used for automatic loading from specified peripheral equipment.
  - d. Contains two manually selectable programs of 32 words each.
4. Instruction Repertoire
- a. In the CP-642B mode there are 62 valid instructions.
  - b. In the CP-642B Mod Mode there are 77 valid instructions.
5. Interrupt and Real Time Clock Control
- The CP-642B Mod permits all interrupts to be selectively enabled or disabled under direct program control. A 30 bit real time clock register is incremented every 1024  $\mu$ sec. This register is at address 160 and is located in control memory.
6. Special I/O Modes of Operation
- a. ESI - When using ESI communication, a channel will allow the peripheral equipment on that channel to specify that the buffer control word is to be taken from any control memory address.
  - b. ESA - When using ESA communication, a channel will allow the peripheral equipment to specify the address of the word transferred to or from any memory address not allocated to the bootstrap memory.
  - c. CDM - When using the Continuous Data Mode communication, the channel will reinitiate the buffer without additional program control when termination occurs.

## D. Memory Assignments

### 1. Main Memory

Addresses	Use
0	Fault Entrance
1-17	Unassigned
20-37	External Interrupt Entrance
40-57	Input Monitor Interrupt Entrance
60-77	Output Monitor Interrupt Entrance
300-477	Unassigned
500-517	EF Buffer Monitor Interrupt
520-537	Interrupt Word Storage Address
600-617	Intercomputer Time Out Interrupt Entrance Address
620-77777	Unassigned

### 2. Control Memory

Addresses	Use
110-117	Input Buffer Control Words
120-137	Output Buffer Control Words
140-157	EF Buffer Control Words
160	Real Time Clock
161-167	B Registers
200-217	ESI Input Buffer Terminate or CDM Reload
220-237	ESI Output Buffer Terminate or CDM Reload
240-257	ESI EF Buffer Terminate
260-277	Unassigned

### 3. Bootstrap

Addresses	Use
540-577	Initial Load Routines

## QUICK REFERENCE DATA

ITEM	CHARACTERISTICS
<b>POWER INPUT</b>	
<b>LOGIC (DC SUPPLIES)</b>	
VOLTS	115 ( $\pm 1\%$ ) VAC (line-to-line)
FREQUENCY	400 ( $\pm 5\%$ ) CPS
PHASES	3
WATTS	3500
PROTECTION	30-amp fuse each line
<b>BLOWERS</b>	
VOLTS	115 ( $\pm 10\%$ ) VAC (line-to-line)
FREQUENCY	400 ( $\pm 5\%$ ) CPS
PHASES	3
WATTS	200
PROTECTION	15-amp fuse each line
OPERATING TEMPERATURE RANGE	0° -50°C (32° -122° F)
COOLING	Centrifugal blowers
<b>OVERTEMPERATURE FEATURES</b>	
OVERTEMP WARNING	Buzzer and light at 46°C (115° F)
OVERTEMP SHUTDOWN	Shutdown at 60°C (140° F)
BATTLE SHORT	Shutdown override
<b>SIGNAL CHARACTERISTICS</b>	
<b>INTERNAL</b>	
"1"	-4.5 VDC
"0"	0 VDC
<b>I/O LINES SLOW INTERFACE</b>	
"1"	0 VDC
"0"	-13.5 VDC
<b>I/O LINES FAST INTERFACE</b>	
"1"	0 VDC
"0"	-3 VDC

## QUICK REFERENCE DATA (CONT.)

ITEM	CHARACTERISTICS
<b>INPUT/OUTPUT CHANNELS</b>	
SLOW INTERFACE	16, 12, 8, 4, or 0
FAST INTERFACE	0, 4, 8, 12, or 16
OPERATION	30-bit, parallel mode
<b>INTERNAL FEATURES</b>	
<b>MAIN MEMORY</b>	
CAPACITY	32,768 thirty-bit words in 2 banks, separately accessed
CYCLE TIME	2 microseconds (1 microsecond effective cycle time with overlap of two banks)
USE	Instruction storage, operand storage
<b>CONTROL MEMORY</b>	
CAPACITY	Thin Film devices 128 words or 256
CYCLE TIME	400 nanoseconds
USE	Index registers, I/O access control, other special controls, auxiliary storage.
<b>BOOTSTRAP MEMORY</b>	
CAPACITY	Two 32 word memories
CYCLE TIME	2 microseconds
USE	Automatic loading from specified peripheral equipment
<b>INSTRUCTION REPERTOIRE</b>	
642B MODE	64 Function Codes (two are invalid)
CP-642B Mod.	78 Function Codes (one is invalid)

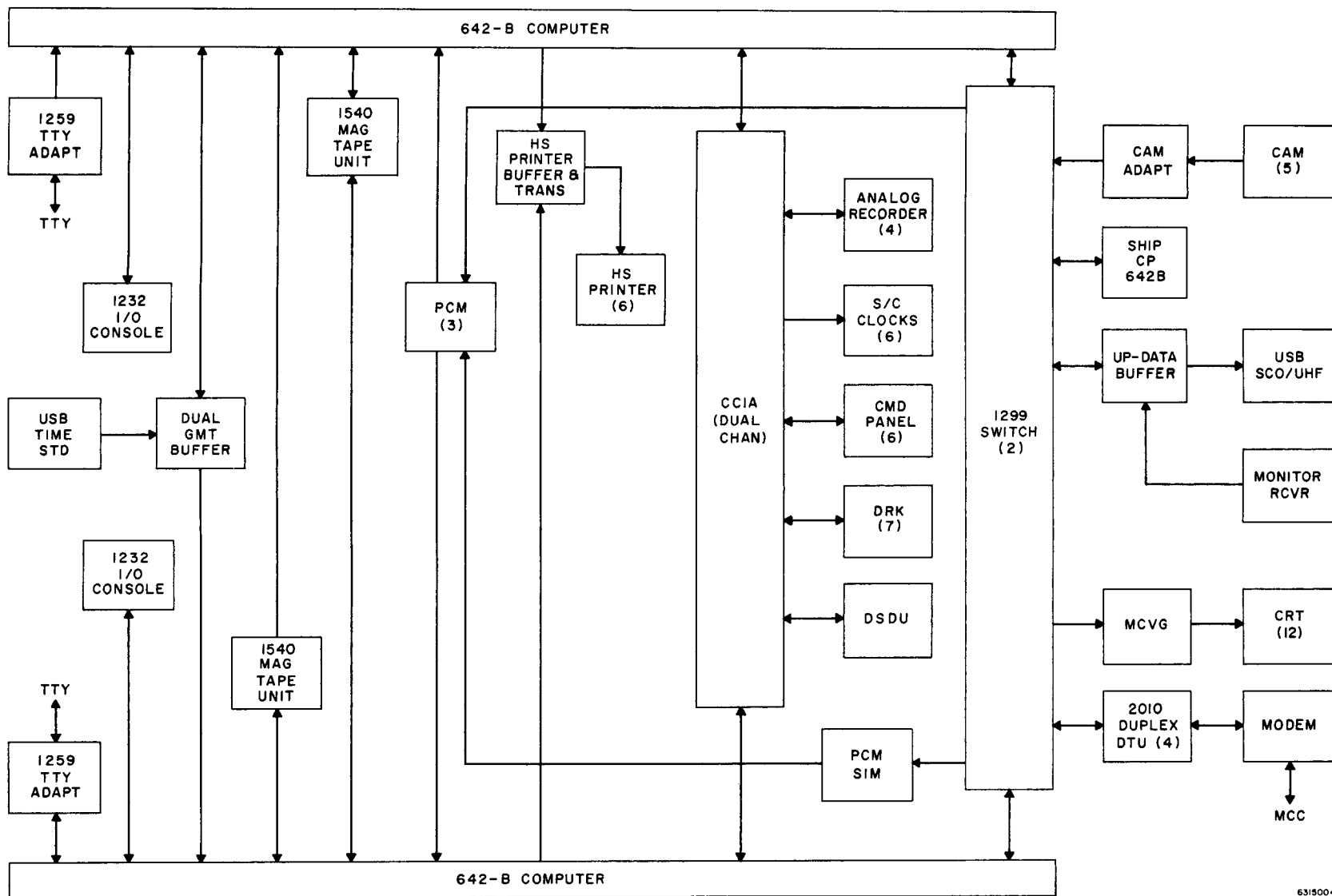

6315004

## 2010 DATA TRANSMISSION UNIT

### DESCRIPTION

The high-speed Data Transmission Unit (DTU) is composed of two modular sections. These modules are an input simplex and an output simplex device each having individual logic which includes clock distribution, character storage, a shift register, and computer interface control. The modularity, therefore, allows flexibility for full duplex operation with the AT&T data modems as well as in simplex combinations. The DTU is enclosed in a cabinet which contains one logic roll-out of the standard 1218 configuration. Located at the front panel will be the necessary controls and indicators for operator and diagnostic control of the entire unit. These controls and indicators are separated into logical sections consistent with the division of the simplex units.

The DTU connects to the CP-642B Mod Computer on a single standard 30-bit computer channel via two standard computer peripheral cables, output data, and input data. Each cable transfers data as well as the control signals associated with the respective data transfers. This particular unit is designed for 8-bit or 10-bit parallel character data transfers. Lines associated with the parallel computer interface enter and exit at the bottom of the figure; lines associated with the serial modem interface enter and exit at the top.

## 1540 MAGNETIC TAPE

The UNIVAC 1540 Magnetic Tape Unit is a large-capacity, medium-speed, auxiliary storage system. It may be operated on-line under complete computer program control as an input/output storage device or with a high-speed printer for off-line printing of tape-recorded information. A flexible format allows recording and reading in four moduli (18, 24, 30 or 36-bit computer words) and three densities, and provides recording and reading of magnetic tapes compatible in all respects with the IBM 727, IBM 729 II, IV and VI system tapes and UNIVAC 1240. Either even- or odd-frame parity may be utilized, and for added reliability, the redundant octal format is provided. A read-after-write feature is provided to check each frame for parity immediately after recording. Longitudinal parity recording and checking is automatic.

Records of data may be of variable lengths and are separated by 3/4 inch interrecord gaps (IRG) unless otherwise extended by suitable programming. Records may be lengthened if suitable interrecord gaps were provided in previous recordings.

The UNIVAC 1540 Magnetic Tape Unit is compatible with all UNIVAC military computers and may be supplied with an 18, 24, 30, or 36-bit parallel input/output interface with either of two sets of logic levels.

The minimum configuration is one controller and two tape transports. The maximum configuration is one controller and eight tape transports.

## UNIVAC 1232 INPUT/OUTPUT CONSOLE

### INTRODUCTION

The UNIVAC 1232 Input/Output Console consists of a paper tape punch, paper tape reader, page printer\*, alphanumeric keyboard\*, control and computer interface logic, and power supplies assembled into a compact unit which operates a single input/output channel. Programs or program modifications may be loaded by the reader on punched paper tape (5- to 8-level) prepared off-line manually or on-line under computer program control by the punch. Alphanumeric entries to the computer may be made at the keyboard with or without printout. The page printer is also a program monitoring device; it provides a running record of real-time and normal program activities. The Input/Output Console may be used with all UNIVAC general-purpose military computers.

\*The keyboard and printer are optional items.



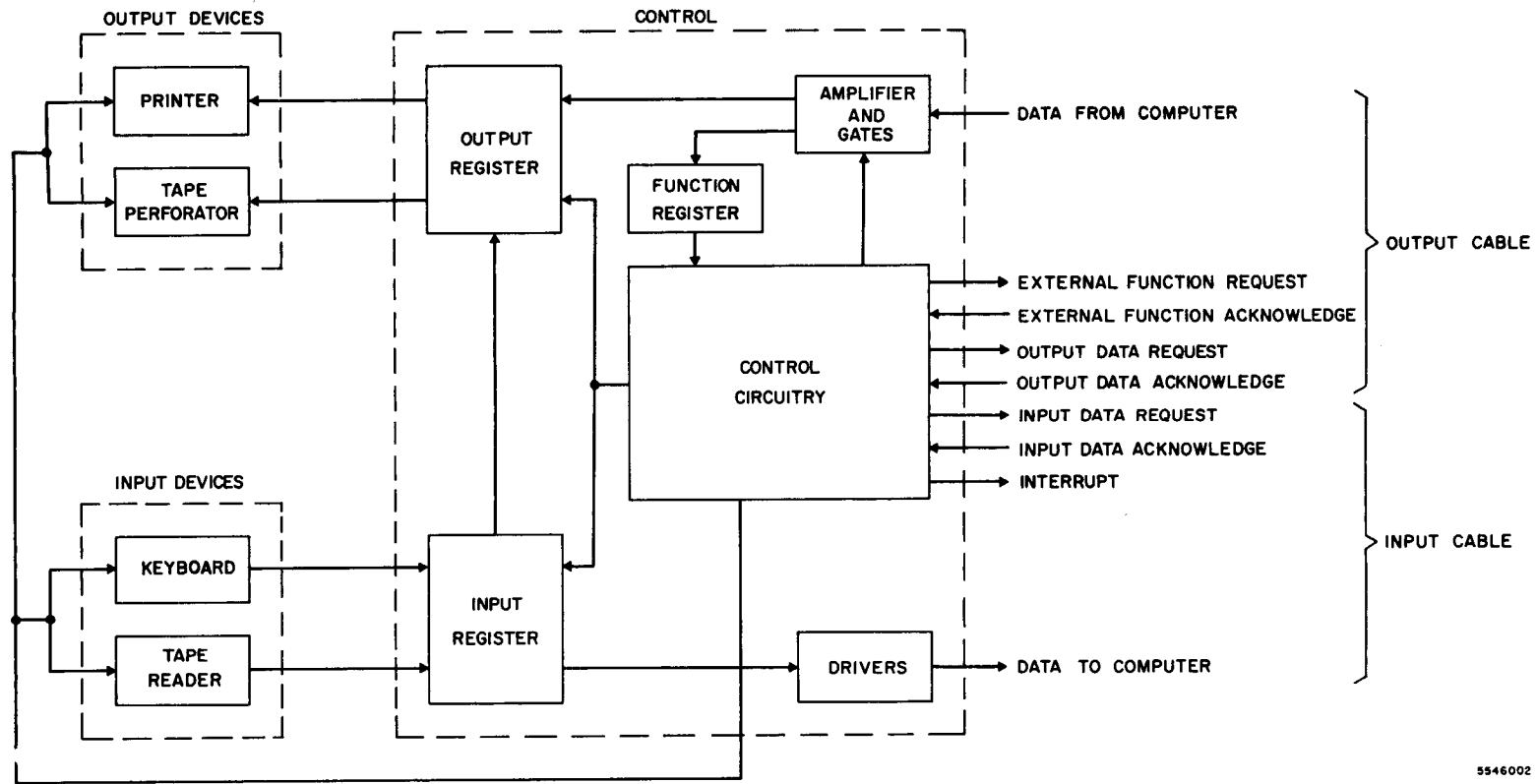

## 1259 TELETYPE ADAPTER

### INTRODUCTION

The UNIVAC Teletypewriter Set is an input/output and monitoring device for use with UNIVAC computers when teletype and line communication is required. The set consists of a Teletype ASR-28 Send-Receive Set, a UNIVAC Adapter (Type 1257, 1259, or 1262) and an auxiliary line relay. The adapter converts the serial nature code transmission characteristics of teletype to the parallel characteristics of the computer and vice versa and provides the logic necessary for interunit communication and buffer operations with the computer. The auxiliary line relay, under control of the adapter, routes data between the teletypewriter and external communication lines. Keyboard or paper tape entries of data may be made to the computer at the site or from some remote locations. Printed copy of punched paper tape outputs of data from the computer may be available at the site or at some remote location. The components of the UNIVAC Teletypewriter Set perform certain functions for the computer system. As a result, the following off-line and on-line operations are possible:

#### a. OFF-LINE OPERATIONS

- Printed and punched paper tape preparation
- Keyboard transmission
- Simultaneous keyboard transmission and paper tape preparation
- Automatic tape transmission
- Page copy of either incoming or outgoing messages

#### b. ON-LINE OPERATIONS

- Keyboard entries to the computer
- Paper tape entries to the computer
- Simultaneous keyboard entries to computer with paper tape copy and/or page copy and/or external line transmission
- Simultaneous paper tape entries to the computer with page copy and/or external line transmission
- Data outputs from the computer to page printer and/or paper tape copy and/or external line transmission

8-15

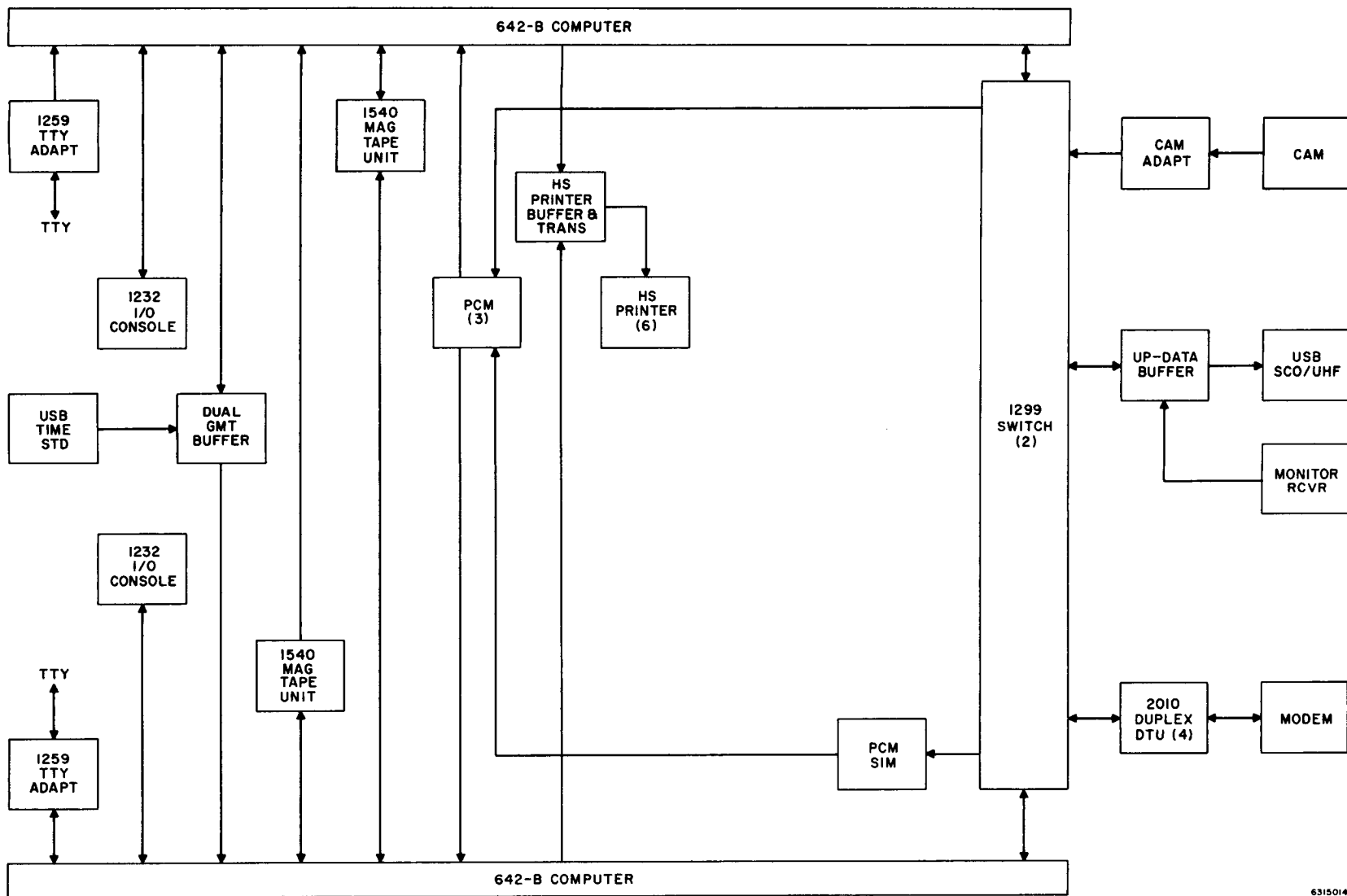

6315014

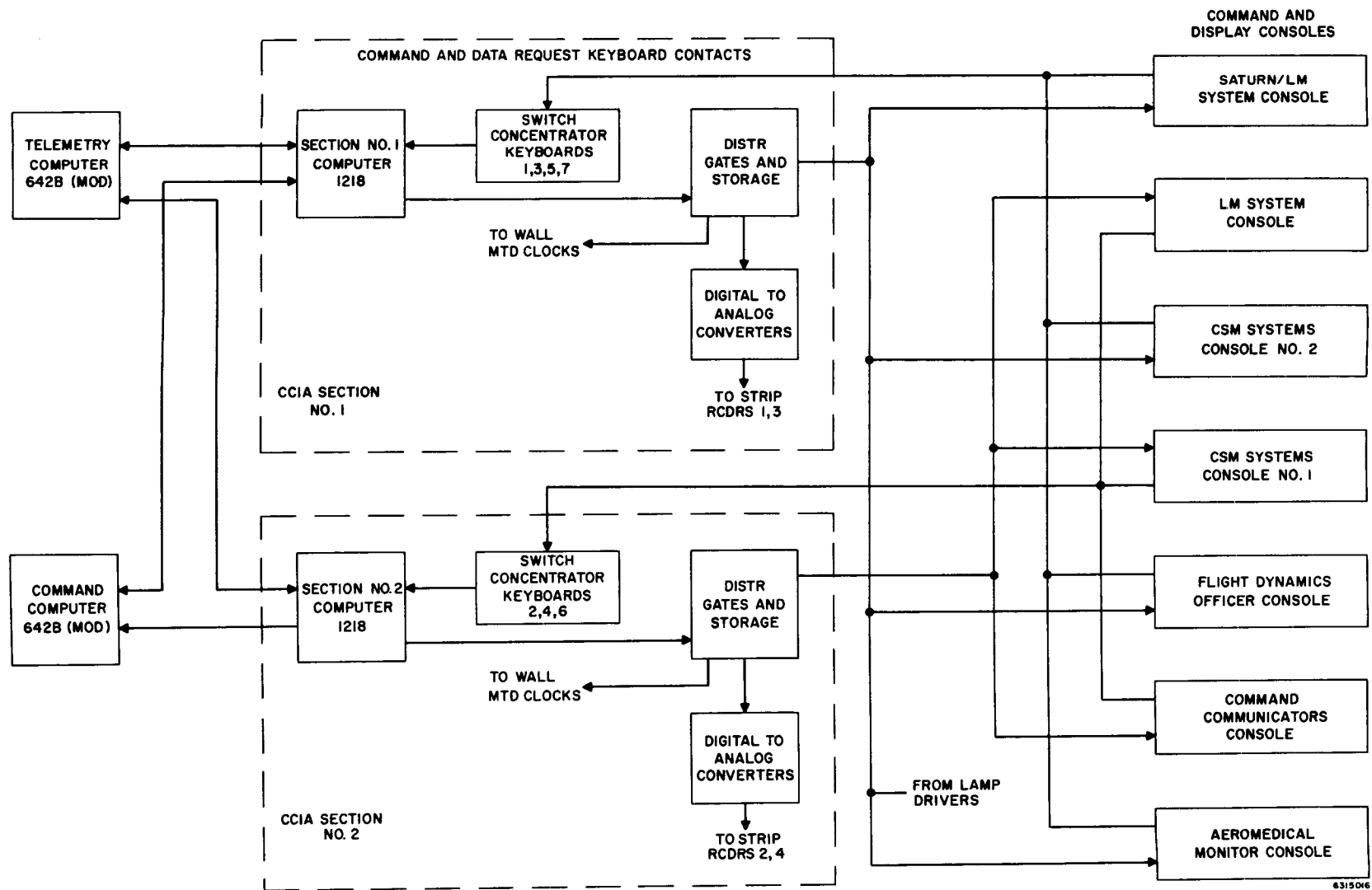

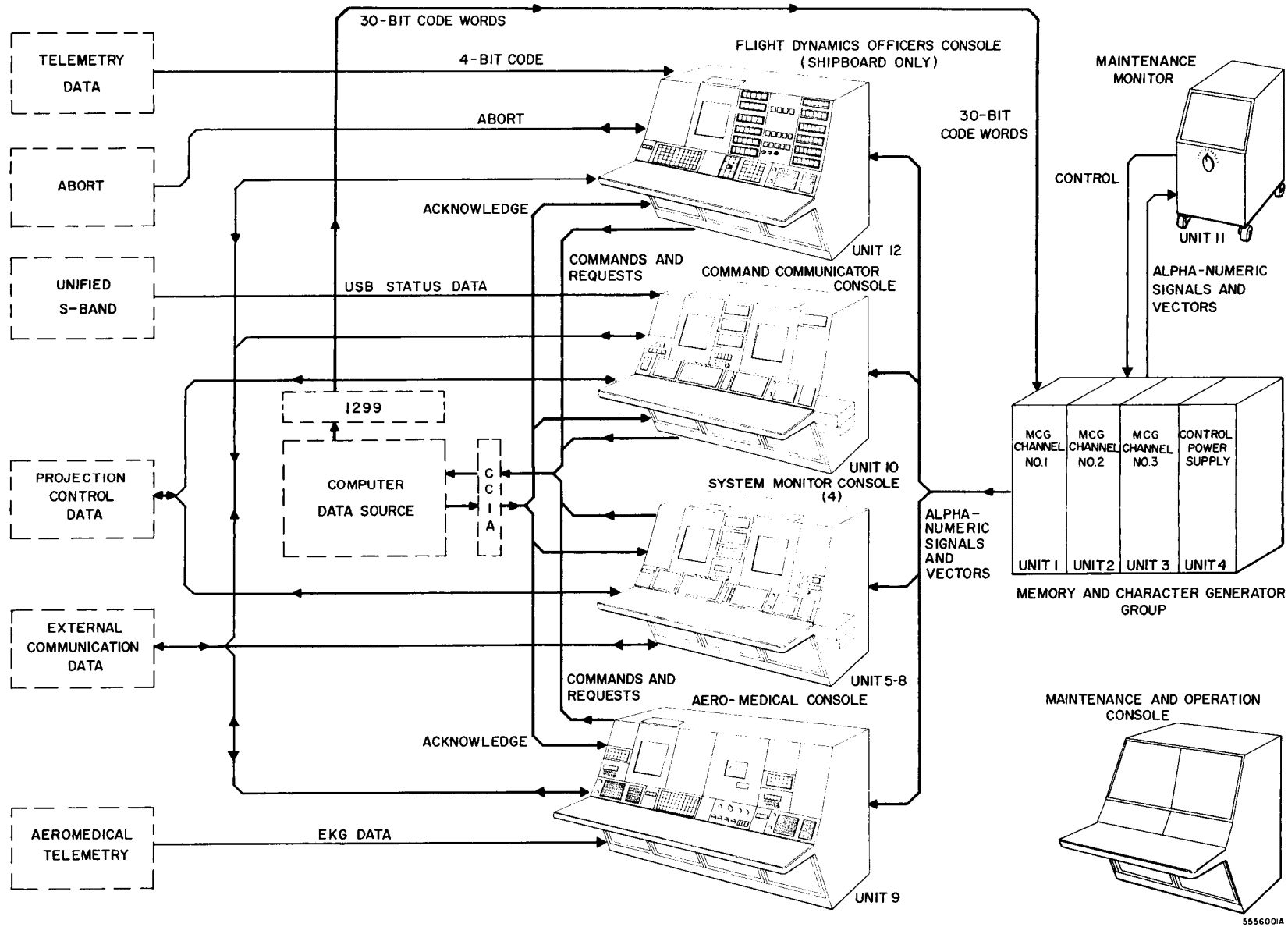

## BASIC DIGITAL COMPUTER TERMINOLOGY

ABORT	The condition in a computer which results in the next sequential instructions being skipped.
ACCESS TIME	The time interval, characteristic of a memory or storage device, between the instant information is requested from memory and the instant the next request for information from memory can be made.
ACKNOWLEDGE	The indication of the status of data on the input/output lines. Abbreviated ACK.
ADDRESS	A coded number that specifically designates a computer register or other internal storage location. Information is referenced by its address. Portions of computer control are responsible for directing information to or from an addressed location.
ADDRESSABLE	Capable of being referenced by an instruction.
ARITHMETIC	A section where logical processes are performed, and operands and results are stored temporarily.
BINARY CELL	An information storing element that can have one or the other of two stable states.
BINARY NUMBER	A number system with two symbols (zero and one) which has two as its base just as the decimal system uses ten symbols (0 - 9) and has 10 as its base.
BINARY POINT	The radix point in the binary system.
BIT	A binary digit, zero or one, represented in a computer by the state of a stage.
BOOTSTRAP	A routine, normally input, contained in memory used for program loading.
BORROW	In subtraction, a borrow is the additional subtraction of a one from the next partial difference. It occurs when a digit of the minuend is a zero and the corresponding digit of the subtrahend is a one.
BRANCH POINT	A point in a program where a decision is made on the basis of current arithmetic results.

BUFFER	A mode of operation that involves interequipment data transfer.
CAPACITY	The upper and lower limits of the numbers that may be processed in a computer's register.
CLEAR	To restore a storage or memory device to the zero state.
CODED PROGRAM	A procedure for solving a problem by means of a digital computer. It may vary in detail from a mere outline of the procedure to an explicit list of instructions coded in the language of the machine.
COMMAND	One of a set of signals or groups of signals resulting from an instruction. Commands initiate the individual steps of the instruction.
COMPLEMENT	In reference to one's complement binary arithmetic, this simply means switching the one bits of a number to zero, and the zero bits to one.
CONTROL	Circuits of the computer that translate the instruction code, and generate the commands that cause the instruction to be performed.
COUNTER	A device capable of increasing or decreasing its own contents upon receipt of separate input signals.
CORE MATRIX	A magnetic core memory plane containing an array of cores, each of which represents the same column for each storage register in the magnetic core storage system.
CORE STORAGE	A type of storage system in which the magnetic core is the basic storage element.
DEBUG	To isolate and remove all malfunctions from a computer, or all mistakes from a routine or program.
DIGIT	One of a set of characters that are used as coefficients of powers of the radix in the positional notation of numbers.
DUMP	Transfer of information from one piece of equipment to another. Generally involves an output of data from a computer.

ENABLE	A signal of given polarity, applied to a gate circuit, that will allow a computer command to be generated.
FLOW DIAGRAM	A graphical representation of a sequence of operations.
FUNCTION CODE	The portion of the instruction word ( $2^{14} - 2^{09}$ ) that specifies to control section which particular instruction is to be prepared.
HALF-SUBTRACT	The bit-by-bit subtraction of two binary numbers with no regard for borrows. Abbreviated as HS. The complement of the half-subtract not, abbreviated as $\overline{HS}$ .
INSTRUCTION	A word which is a coded directive to the control section to initiate a prescribed sequence of steps necessary to effect a particular logical operation. Three types--read, write, and replace.
INSTRUCTION CODE	Designators constituting an instruction word. The designators are listed below as they appear from highest to lowest order significance in the instruction word: f - Function Code j - Branch Condition k - Operand Interpretation b - Address Modification u or y - Operand
INPUT/OUTPUT	A section providing the means of communication between a computer and external equipment, or other computers. Input/Output operations involve units of external equipment, certain computer registers and portions of a computer control section.
INTERRUPT	(1) Internal: indicates the termination of an input or output buffer. (2) External: signal on the data lines that requires computer attention.
JUMP	An instruction which may, depending upon the contents of a given register or position of a given switch, cause the normal sequence of instructions to be interrupted, and an instruction at a remote address to be executed.



LOAD	To enter information into a computer or a storage location.
LOGICAL PRODUCT	The bit-by-bit multiplication of two binary numbers.
LOOP	Repetition of a group of instructions in routine or program.
MALFUNCTION	Nonoperation of the computer because of a component failure.
MARGIN	A measure of the tolerance of a circuit, the range between an established operating point and the point at which the first circuit starts to fail.
MASTER CLOCK	The primary source of timing signals.
MEMORY	Any device into which information can be introduced, stored, and then extracted at a later date.
MODULUS	The number of values a register can represent. For example: if only the integers from -15 to +15 can be represented in a register, the modulus of this register is 31.
NON VOLATILE STORAGE	Storage media that retain information in the absence of power.
OCTAL NUMBERS	A number system using eight symbols (0 - 7) and having eight as its base.
OPERAND	Coded data representing a number that is involved in computer operations or results from computer operations.
OVERFLOW	The condition which arises when the result of an arithmetic operation exceeds the capacity of the number representation in the computer.
PARALLEL TRANSMISSION	The system of information transfer in which the characters of a word are transmitted simultaneously over separate lines.
PROGRAM	A sequence of coded computer instructions and necessary operands for the solution of a problem.
PAPER TAPE READER	An input device that reads the coded information contained on a punched paper tape by means of photoelectric cells.
RADIX	The number of individual characters used in a number system. Decimal uses ten characters (0 - 9) radix 10. Octal uses eight characters (0 - 7) radix eight. Binary uses two characters (0 - 1) radix two.

READ	To extract information.
REAL TIME	Computer operation with regard to a specific event or time.
REGISTER	A storage device, usually made up of a series of flip-flops capable of storing a computer word. The condition of the flip-flops ("1" or "0") is usually indicated on a computer maintenance console by a series of neon indicators.
ROUTINE	A sequence of instructions that causes a computer to execute a specific part of a computer program.
SCALE	To shift a binary number either right or left in a register so that the number can be used for further computation in a computer.
SERIAL TRANSMISSION	A system of information transmission in which the characters of a word are transmitted in sequence over a single line as contrasted to parallel transmission.
SET	To change the state of a register to some value other than zero; to change the state of a stage of a register from "0" to "1".
SHIFT	Displacement of an ordered set of characters one or more columns to the right or left.
SIGN DIGIT	A character used to designate the algebraic sign of a number.
SINGLE ADDRESS (Instruction Code)	A system whereby any instruction of a given repertoire will reference only one address of storage while the instruction is being executed.
STAGE	An electronic device or building block with bistable characteristics that enable the device to hold or represent a zero or one.
STORAGE	Consists of devices in which information is set aside for immediate or future use.
TRANSLATION	A change of information from one language or means of representation to another.

TRANSFER

A change of information from one location to another.

VOLATILE STORAGE

Opposite of nonvolatile storage. Information is lost in the event of a power interruption.

WORD

Information coded for computer representation as a series of bits.

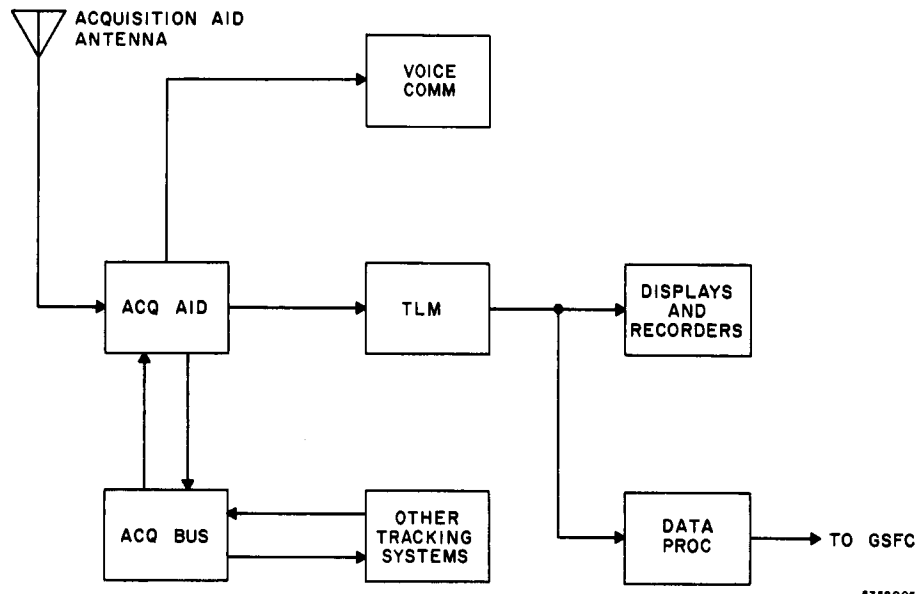

5358005

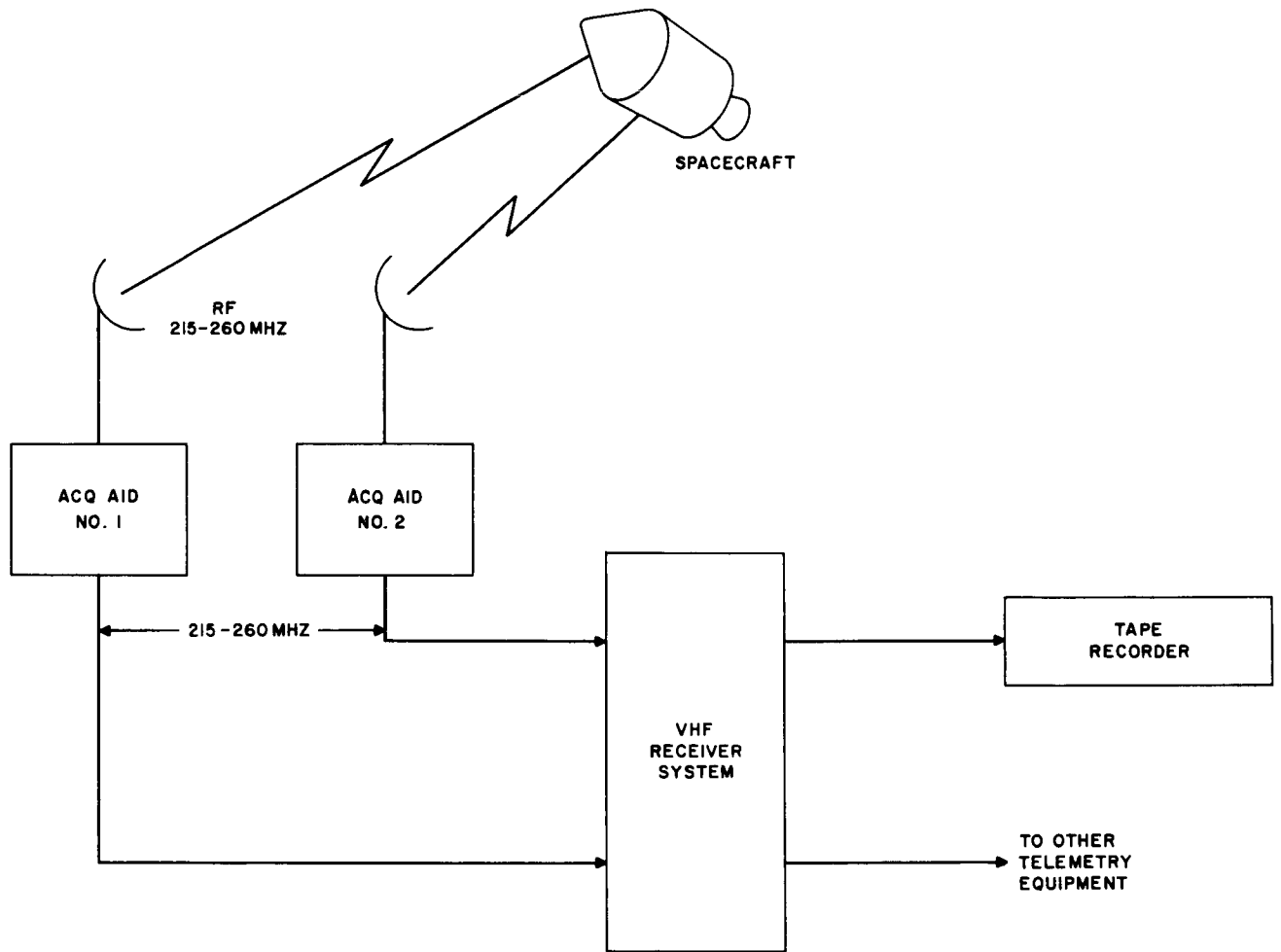

6315012

# TELEMETRY

## PRINCIPLES OF TELEMETRY

### INTRODUCTION

Telemetry consists of performing measurements at a remote location and reproducing these measurements at some convenient location in a form suitable for display, recording, and possibly for insertion into data reduction equipment. The connecting link between the two locations may be a light beam, a radio, a wired connection, etc. In this discussion we will be concerned only with radio links from orbiting spacecraft or their launch vehicles.

### TELEMETRY

In general there are three methods of obtaining data from an orbiting spacecraft: (1) astronaut observations and noting the readings of instruments; (2) airborne recording of instruments (3) radio telemetry. The first method is obviously limited to qualitative data trends and to a few datum points per unit time, because of the reaction time of the observer and the time required to record the data. The second method cannot fulfill the real time demands of the Manned Space operations. Thus, the third method is the only practical means of relaying the necessary measurements.

#### A. Data

The type of measurement to be made in the capsule can vary widely. (Measurement is used here in its most general sense, i.e., we can measure the on/off status of a beacon, or the count of a clock as well as measuring lbs/in<sup>2</sup>, or degrees of temperature.) Typical examples include temperature, pressure, acceleration, radar beacon status (on/off), power supply voltages, capsule attitudes (pitch, roll, yaw), capsule elapsed time clocks, etc. From the standpoint of telemetry, these can be classified in two general categories: analog and digital.

##### 1. Analog

The greater majority of analog measurements are nonelectrical by nature. Temperatures, pressures, liquid levels, are examples of conditions which must be processed to an electrical signal by means of a device called a transducer. The following table lists some typical parameters and typical transducers employed.

Parameter	Transducer
Temperature	Bimetallic strip, resistance bulb, thermistor, thermocouple
Moisture	Hygrometers - ceramic, thermocouple, lithium chloride
Light	Photoconductive cells - cadmium sulphide, selenium
Acceleration	Accelerometer
Liquid Level	Capacitance bridge, float
Pressure	Bourdon tube, strain gauge, Pirani tube
Fluid Flow	Flowmeters - positive displacement, turbine type, electromagnetic
Radioactivity	Scintillation counter, Geiger-Muller Tube counter, ionization chamber
Color	Spectrophotometer, colorimeter
Acidity and Alkalinity	ph Potentiometer

## 2. Digital

In the category of digital information we can include such things as clock readouts, computer words and the simple on/off "events" (beacon on/off, umbilical open/closed, parachute deployed/not deployed, etc.). These parameters generally are already in electrical form, but those that are not can usually be made electrical through the use of a simple transducer such as a microswitch.

### B. Multiplexing

Since the number of measurements to be made in a spacecraft can easily be in the hundreds and occasionally into the thousands, it is extremely impractical to provide separate transmitters and receivers for each measurement to be made. Some means must be used to combine measurements in a manner such that the largest possible number can be transmitted over a single RF link. The process of combining these channels is known as multiplexing.

Although other methods are conceivable, there are two principle means of multiplexing; frequency-division multiplex and time-division multiplex.

In frequency-division multiplex, each data channel modulates a corresponding subcarrier. The subcarriers are then mixed into a composite signal which is then used to modulate the transmitter. At the receiving station, the carrier is

demodulated giving us the composite of subcarriers. This composite is then passed to a bank of filters, each tuned to accept only one of the subcarriers present in the composite. These separated subcarriers must then be demodulated to recover the original data.

In time-division multiplex, the various measurements are connected sequentially to the line (commutated) and the resulting signal is used to modulate the transmitter. At the receiver, the same process occurs in reverse. Some kind of signal distributor or decommutator arrangement is required to "sort" the samples as they arrive in sequence and distribute them to the appropriate lines at the proper instants. This requires precise synchronism between transmitter and receiver. If synchronism fails, all channels are garbled and lost.

#### 1. Frequency-Division Multiplexing

Frequency-division multiplexing as applied to telemetry consists almost entirely of FM/FM or FM/PM.

In this type of multiplex system, all information channels are transmitted simultaneously; thus, commutation and decommutation are unnecessary. This eliminates the problems of synchronization that exist in the various time-division multiplex systems such as PAM, PDM, and PCM. In FM/FM telemetry, a main carrier is frequency modulated by several subcarriers which are themselves frequency modulated. The transducer output voltages of each channel serve as the modulating signals for these subcarriers. Each transducer output signal drives a subcarrier generator (VCO). The subcarriers and their respective sidebands are routed to a modulator where they form a composite signal which serves to modulate the main carrier generator. The receiver routes this signal to bandpass filters, each of which passes only the frequency components of one channel. The corresponding discriminators detect the subcarriers and their sidebands and generate approximations of original transducer output signals.

In practice, one or more of these channels may be used with one of the time-division commutation schemes that will be discussed later.

One of the prime requirements of any telemetry system is accuracy. In the FM/FM system where the data causes the frequency of the subcarriers to change,



the changes of subcarrier frequency due to natural causes (drift) must be minimized lest the changes resulting from drift be misinterpreted as changes in data. Since the drift can never be completely eliminated, an amount of uncertainty will always be present. Additionally, when these signals are recorded as a subcarrier composite at the ground station, some means must be used to minimize the effects of the tape recorder wow and flutter. This is not difficult, but it does increase the complexity.

Probably the greatest disadvantage is the limited number of subcarriers allowed in the Inter Range Instrumentation Group (IRIG) recommendations. In the interest of standardizing systems, IRIG has recommended a maximum of 18 subcarriers on a single transmitter. This means then, that unless one or more of the channels are utilized to transmit a time-division multiplexed signal, we are left with a maximum of 18 measurements.

This also means that a simple digital channel such as an event that might occur once during the mission will use as much channel capacity as a rapidly moving waveform such as the EKG waveforms of manned space. Analog data is quite compatible, but our digital data must be converted into some analog voltage levels, with either a loss of accuracy on complex digital data, or a fantastic consumption of channel space.

## 2. Time-Division Multiplex

Time-division multiplex is based on the premise that it is not necessary to continuously monitor a signal in order to reproduce it with an acceptable degree of accuracy. It is only necessary to periodically measure (sample) the amplitude of a function during discrete time intervals.

### a. Sampling Theory

Suppose that it is desired to transmit the time varying signal. By sending the voltage  $V(t)$  through a communication system in the form shown, an exact reproduction of the waveform can be expected at the receiving end (assuming reasonable high signal-to-noise ratio, of course). But it is not necessary to transmit  $V(t)$  continuously in order to derive the information contained therein.

It is the changes in the voltage levels of a signal which contain the information; therefore, in order to get all of this information, all the voltage changes must be determined.

It is obvious that  $V(t)$  is changing with time because of the valleys and peaks. Suppose that we cause  $V(t)$  to pass through a switch that is opening and closing at an arbitrary rate. Obviously when the switch is closed,  $V(t)$  appears at the output; when the switch is open,  $V(t)$  does not appear at the output. If the switch is closed for a time ( $T_1$ ) and open for a time ( $T_2$ ), then the waveform shown in C is obtained at the sampler output. This output does not resemble  $V(t)$ . Now suppose that the switch is again closed for a time ( $T_1$ ) but opens for an equal amount of time; this action produces the waveform of D which begins to resemble  $V(t)$ . The signal is sampled each time the switch is closed. The width of these sampling pulses can become wider and wider until the limit, which is the original waveform  $V(t)$  is reached.

Now instead of using wide sampling pulses, visualize very narrow pulses which are equally spaced, but close together. The result shown in E is obtained. These pulses, like those of D, also form an envelope which has the shape of  $V(t)$ . If the sample is taken at too low a rate, the signal may change radically between sampling pulses and a distorted output would be obtained as shown in C. Obviously, the more pulses that are used, the more accurate the envelope will be. However, the problem here is to use as few of these sampling pulses as possible and still derive an accurate envelope. Thus, it is necessary to determine the minimum rate ( $f_s$ ) that a signal can be sampled at and still derive the information contained within it.

Before this can be determined, a restriction must be placed on the signal. In any communication system, there exists a bandwidth limitation. Otherwise, one information channel will fall into the adjacent channels and the result would be gibberish. Limiting the bandwidth also reduces the amount of noise (because noise power decreases with decreasing bandwidth), thereby increasing the signal-to-noise ratio. Since the signal is band-limited, it has a maximum frequency component ( $f_m$ ). Therefore, the fastest that a signal can change is obviously determined by the bandwidth (also  $f_m$ ). The sampling theory of modern communications theory states that:

$$f_s \geq 2f_m$$

This means that if a band-limited signal is sampled at a rate which is at least twice the maximum frequency component of this signal, a relatively good production of the signal can be obtained.

If there is an amount of detail in the waveform that must be preserved, a higher sampling rate must be used. Sampling rates as high as ten times the frequency components of the signal are not unusual. In all cases, however, the samples must be equally spaced.

#### b. Commutation

The time intervals between samples are not wasted; other time varying signals can be sampled and these samples can then be sandwiched into the unused time intervals. This method of time sharing produces what is known as a commutated wave train.

Each signal is connected to a four-pole rotating switch whose wiper arm rotates at a constant speed. Each time the arm touches a terminal, a sample is taken. The amplitudes of these sample pulses are equal to the instantaneous amplitude of the signal being sampled at the moment. Connecting the peak of every fourth pulse of the sampled output then gives an approximation of the original signals. Note that switch S2 must be in precise synchronism with the sampling switch S1; S2 must be resting on contact 1 at the same time that the sampling switch S1 is resting on contact 1. Both switches must of course rotate at the same speed.

It is this requirement for precise synchronization which has limited the usefulness of time division systems in the past. Modern techniques and the use of Pulse Code Modulation have greatly extended the capacity and versatility of time division systems.

#### c. Commutation Diagrams

In discussing time-division multiplex schemes, it is convenient to diagram the sequencing of the channels as they appear at the output of the commutator. There are two principle types of diagrams in use: the wheel diagram and the matrix diagram.

### (1) Wheel Diagrams

The wheel diagram is analogous to a mechanical airborne commutator. The arm in the center of the diagram, from which the output is taken, is assumed to rotate in a clockwise direction, being first connected to channel (segment) 1, followed by channel 2, then channel 3, and channel 4.

Upon completion of the transmission of channel 4, channel 1 is transmitted, beginning the sequence again, and continuing indefinitely. This system is too simple to be very practical, and further, no provision has been made for synchronization.

One complete rotation of the wiper of this wheel, consisting of the samples of channels 1 through 15, is known as a FRAME. Since the wiper rotates at a constant rate of speed, the frame rate of the system is equal to the rotation rate of the wiper. They are generally specified in frames per second and rotations per second (rps), respectively. It can also be seen that because each of the channels occurs only once per frame, the sampling rate in the individual channels is equal to the frame rate.

### (2) Matrix Diagrams

A matrix diagram of the simple formats that we have been discussing is not really necessary, and indeed, is not even a matrix. It is being introduced at this time purely for comparison purposes. Since there appears to be no standard for matrix diagrams, there are as many types as there are designers. The only type that will be discussed here is known as an "X-Y" matrix.

The general form of the "X-Y" matrix diagram is merely that the wheel has been opened between the frame synchronization channel and channel 1, then laid out in a horizontal line. This horizontal line is one frame in length, beginning with channel 1 and ending with the synchronization channel.

Although it is not yet apparent, successive frames need not be identical. Our matrix will take the form of a chart in which channel numbers progress in one dimension, and successive frames will be plotted in the other.

#### d. Supercommutation

The system just discussed would be satisfactory if all the parameters required the same sampling rate. In the example shown, the sampling rate of all channels is 1 sample per second. Sampling theory has told us that the maximum frequency that can be satisfactorily passed through a channel is equal to one half of the sampling rate. The maximum changes that can be passed by the above system then is equal to 0.5 cycles per second.

Suppose we find that among the parameters to be measured, one channel has a requirement for a 2-cycle-per-second (cps) response, a second channel has a requirement for 1 cps response, and the remaining channels have a requirement for 0.5 cps response. The first solution to the problem might be to increase the speed of the commutator to 4 rps. This would then provide all channels with a 2 cps response. As might be expected however, if we transmit more than we need, as in this case where the majority of channels require only 0.5 cps response, we are not operating at maximum efficiency. A better solution to the problem is called SUPER-COMMUTATION.

Supercommutation, the preferred term, is sometimes called strapping. Supercommutation (strapping) is commutation at a higher rate by connection of a single data input source to equally spaced contacts of the commutator.

Note that parameter PX 9 now is sampled four times per frame in channels 2, 6, 10, and 14, but that the speed of rotation of the wiper remains at 1 rps. We now have a sampling rate of 4 samples per second and corresponding frequency response of 2 cps.

Parameter N 28 is now sampled twice per frame; once in channel 4, and again in channel 12 for a sampling rate of 2 samples per second and corresponding to a frequency response of 0.5 cps.

We have effected a trade, increased frequency response for some channels for a loss of total channel capacity, in this case four channels. This need not be a complete loss. If, in the first example, we had increased the commutation rate by four times, the width of the individual channels/pulses would have decreased to 25% of their original value. This decreased pulse width would have forced us to

increase transmitter power and receiver bandwidth in order to maintain the original signal to noise ratio. In the example with supercommutation, if these four channels were 0.5 cps channels, we could increase the frame length to 19 channels and if we maintained the same sampling rate, the pulse width would be reduced to 80% of the original value. This too would require increased power and bandwidth, but of course not nearly as much as the reduction to 25%.

Supercommutation then is a means of increasing the overall efficiency of a system by its ability to supply the optimum sampling rates for the channels to be transmitted.

e. Subcommutation

Although supercommutation can give us a wide variety of sampling rates, it does have some disadvantages when there are a great number of measurements to be made that require supercommutation to give the desired sampling rates. The ground station must make special provision for each channel that is supercommutated, usually by some special patching facility. These special patching facilities are limited in number. As we increase the number of measurements to be made, we are simultaneously increasing the length of the frame. Since the frame synchronization channel is transmitted only once per frame we cannot have the same degree of confidence in our synchronization because it is occurring less frequently. It is primarily for this reason that another means is used to increase the channel capacity without decreasing the frame synchronization confidence level. This method is called SUBCOMMUTATION.

In subcommutation, one or more commutators are employed in addition to the main commutator. The output from the wiper of a particular subcommutator is connected to a particular channel location on the main commutator. Since the wiper of the main commutator must rotate at a constant speed, this channel location can still contain only one parameter per frame. The subcommutator must then run at a rate of speed such that it advances only one parameter or channel per rotation of the wiper in the main commutator.

If this is true, then it will require a number of frames to be transmitted before all of the parameters on the subcommutator can be transmitted. The

precise number of frames that must be transmitted is of course equal to the number of channels on the subcommutator.

Just as one revolution of the wiper of the main commutator is known as a frame, one revolution of the wiper on the subcommutator is called a SUBFRAME. Parameters (channels) connected to this subcommutator are known as subcommutated parameters (channels) as differentiated from commutated or supercommutated parameters. (Although all channels are, technically speaking, commutated channels. The term commutated is generally used to identify those channels which are transmitted only once per frame.)

In an example, a subcommutation ratio is 6:1. That is, the subcommutator is rotating at one sixth the speed of the main commutator, the subcommutated channels are being sampled at a rate which is one sixth that of the commutated channels. This also means that six frames must be transmitted before all the parameters have been sampled at least once. This latter condition, when all parameters to be transmitted have been sampled at least once, is called a FIELD and in this case is equal to the subframe.

In order for the ground station to know which frame of the six is being transmitted, it is necessary to transmit a synchronization signal once per subframe. Here we have chosen to use the last channel space on the subcommutator for this purpose.

It is possible to apply subcommutation to any of the channels in the frame, excepting the frame synchronization channel. These additional subcommutators may or may not operate at the same ratios. One synchronization channel can be used to synchronize all subcommutators of the same ratio, as well as ratios which are integral sub-multiples of a ratio having synchronization.

#### f. Sub-Subcommutation

In the interest of further increasing channel capacity as well as supplying greater spread from maximum to minimum sampling rates, commutators can be connected to the segments of the subcommutators. These commutators are actually subcommutating a subcommutated channel, and are therefore known as SUB-SUBCOMMUTATORS.

The operation of these sub-subcommutators follows the same pattern that we have established for the subcommutators. The principle difference is that the rate of rotation of the wiper of the sub-subcommutator is now some sub-multiple of the rotation rate of the subcommutator. Again, because the output of the sub-subcommutator is occupying one channel space in the subcommutator, only one channel from the sub-subcommutator can be transmitted per rotation of the subcommutator (one channel per subframe). It will now require a number of subframes before all of the channels from the sub-subcommutator can be transmitted. The precise number of subframes will be equal to the number of channels on the sub-subcommutator. This group of subframes is called a SUB-SUBFRAME.

If sub-subcommutation is employed, the largest sub-subframe will be equal to the FIELD. (Only after the largest sub-subframe has been transmitted, have transmitted at least one sample from all parameters.)

At this time, we may be getting the impression that we are covering some rather improbable circumstances. We are not. The signal transmitted from the Gemini spacecraft has the following characteristics:

8X Supercommutation	Sampling rate equal to 640 sps
2X Supercommutation	Sampling rate equal to 160 sps
Commutated Channels	Sampling rate equal to 80 sps
2:1 Subcommutation	Sampling rate equal to 40 sps
4:1 Subcommutation	Sampling rate equal to 20 sps
8:1 Subcommutation	Sampling rate equal to 10 sps
24:1 Sub-Subcommutation	Sampling rate equal to 0.416 sps

Although we have been using diagrams and terminology to imply that the commutators are rotating switches, this is not necessarily so. Mechanical commutators have been used extensively in the past, however modern solid state technology has given birth to electronic switching systems many times faster and more reliable. A commutator may also be called a sequencer, or programmer.

### 3. Time-Division Multiplex Encoding

The output of the samplers that we have just described can be used to modulate the transmitter directly, or it can be used to modulate a subcarrier oscillator in the previously described FM/FM system.



a. Pulse Amplitude Modulation (PAM)

We are sampling an analog signal at a fixed sampling rate to produce a series of equally spaced pulses with amplitudes equal to the signal amplitude at the moment of sampling. Thus, the pulse trains shown are an example of Pulse Amplitude Modulation (PAM). The relative value of the measured variable is conveyed by the relative amplitude of the pulse from the sampler. PAM is the simplest form of time-division multiplexing because the samples are transmitted without further processing into another form. It has been shown in detailed studies that where linearity and resolution requirements can be satisfied by an analog system, PAM is the best multiplexing system from the standpoint of achieving maximum information capacity in minimum bandwidth. This might be expected because, PAM is basically an amplitude modulation process and shares the narrow band properties of AM.

PAM is a good multiplex system as long as the transmission channel is quiet. Since noise is unavoidable in many instances, PAM signals become easily distorted because the information is contained in the pulse heights. Therefore, anything which alters the amplitude of these pulses causes signal distortion.

b. Pulse Duration Modulation (PDM)

In Pulse Duration Modulation (PDM) the analog signal is sampled as in PAM. The resulting PAM wavetrain is converted into a series of pulses of varying widths proportional to the amplitude of the respective samples. Thus, the information is contained in the pulse widths or durations. The height of these pulses is constant. PDM is sometimes referred to as PWM (pulse width modulation).

PDM, however, is not as efficient in transmitting data as PAM under marginal signal-to-noise ratio conditions. This is because pulses of longer duration must be transmitted to provide the same information as high amplitude PAM pulses, and more transmitter power is required. For any given degree of data accuracy, PAM has several decibels in its favor over PDM. However, because of the simplicity and high reliability of PDM systems and equipment, PDM is used because problems of linearity are more readily solved with PDM than with PAM.

Because all the information is contained in the width of the pulses, noise can readily cause deterioration of the pulse widths. Therefore, anything

which affects the shape of the leading and trailing edges of a PDM pulse will produce erroneous signals.

c. Pulse Position Modulation (PPM)

Pulse Position Modulation is a form of PDM in which only the leading and trailing edges of the PDM pulses are represented by a very narrow pulse. The principle advantage, as compared to PDM, is in the conservation of transmitter power. As the data in a PDM channel changes, the changes are reflected in the difference of time between the leading and trailing edges of the pulse, but we still must transmit RF power in the time between these transitions. If instead, we transmit very short pulses to indicate where the leading and trailing edges are, we can save on transmitter power. Pulse transmitters similar to those used in radar can be employed, giving us a very high peak power but very low average power.

In general, PPM suffers the same disadvantages as PDM in the presence of noise.

d. Pulse Code Modulation (PCM)

Unlike the methods which we have been discussing (where the data varies some characteristic of a pulse, amplitude, width, position, etc.), the sampled values observed are represented by a coded arrangement of several pulses. Thus, only the presence or absence of pulses -- not their shape -- determine the received message and its quality.

This is very similar to conventional teletypewriter communication in which the transmitted characters are represented by various combinations of a five pulse code. Regardless of how badly the code pulses may be distorted or degraded in transmission, the sharpness or clarity of the characters reproduced at the receiving printer are obviously not changed or altered in any way. Distortion of the transmitted pulses merely increases the chances of a mistake in interpreting the code and the printing of a wrong character.

Because it is a digital system, it is compatible with airborne digital data from computers, clocks, and event functions as well as ground handling equipment. Binary digital data can be handled directly without further processing. On/off information is usually grouped so that each transmitted channel actually contains

four or more events. Analog information must be quantitized and encoded into a binary number for transmission.

Page 10-20 shows a block diagram of a PCM system spacecraft and ground components. In the spacecraft system, the encoder performs the analog to digital (A/D) conversion function. The programmer controls the operation of the commutator so that digital words may be interleaved with the analog channels. In the ground system, the signal conditioner regenerates the incoming signal, supplying a noise free input to the decommutator, as well a train of timing pulses (bit rate clock) that define the pulse periods. The storage unit corresponds to an output holding circuitry for digital information, while the decoder provides conversion from digital to analog (D/A) for the analog output devices. The operation of the decommutator, storage unit, and decoder are all controlled by the synchronizer.

#### (1) PCM Quantitization

When analog information is to be encoded, the signal to be transmitted is first broken up into a prescribed number of discrete amplitude levels. Each level is assigned a binary number value (a specific combination of pulses) which is then sent through the communication channel. The ground station converts the binary number back to an approximation of the original signal value. The process of breaking up the signal into discrete levels is known as quantitization.

Use as an example an uncoded signal (continual amplitude variation) which is to be encoded. A signal varies between zero and plus seven volts. It is desired to convert the signal into eight discrete voltage levels: 0, 1, 2, 3, 4, 5, 6, and 7 volts. For the purpose of illustration, the amplitude of the waveform is sampled at one second intervals (or any other sampling interval may be used). If the amplitude lies between 0.5 volts and 1.5 volts, the 1 volt value is assigned; between 1.5 volts and 2.5 volts, 2 volts is assigned, etc. Thus, the quantitized waveform is derived. By connecting the discrete levels between every 1 second interval with a dashed line, it can be seen that the original waveform has been reproduced in a very rough manner. It is obvious that the demodulated signal (dashed lines) differs somewhat from the original signal. The effect is as if noise has been introduced into the system. This quantitization noise can be reduced by breaking up the original signal into more discrete voltage levels. It can be seen

that the demodulated signal of (c) is an improved reproduction of the original signal. If the signal would be sampled more frequently, then the reproduced waveform would become even more accurate. Bandwidth and noise determine the maximum sampling rate and the number of levels which may be used in any given communication system.

For transmission, each discrete quantization level is encoded into a definite series of pulses in such a manner that only the presence or absence of a pulse is significant; exact pulse shape is secondary. The presence of a pulse is denoted by a 1 and the absence of a pulse by 0. Where eight discrete levels are used, it can be seen that each level can be expressed as a series of pulses with a maximum count of three pulses. By adding one more pulse position, the count is increased to 16 discrete levels with a maximum count of four pulses. Thus by using more pulses, a more accurate reproduction of the original signal may be achieved. However, the transmission of more pulses requires the reduction of the pulse width (assuming a constant information rate) which in turn places a greater bandwidth requirement on the system. By adding the extra pulse, the number of quantization levels is doubled. For example, the quantizing into 32 levels requires a maximum of five pulses. Even though the addition of pulses increases the bandwidth requirement, the signal-to-noise ratio improves in an exponential manner. Uncoded systems have signal-to-noise ratio improvements which increase linearly. There are, however, other pulse coding techniques which can transmit the same amount of information within narrower bandwidths.

#### 4. Time-Division Multiplex Synchronization

The prime requirement for a frame synchronizing channel is that it must bear as little resemblance as possible to the data channels and still be compatible with the type of encoding with which it is being used. In the case of PAM, it can have greater amplitude than data, (over 100%), it may be at the 100% level from 1.5 to 3 times as long (i. e. 1.5 to 3 times as wide as a data channel), or it may contain a digital code. The fact that it is limited to a simple pattern makes it difficult, though by no means impossible, to use subcommutation, because the subcommutator must also have a synchronization pattern which has the same restrictions concerning its resemblance to data, and in addition it must not resemble the frame sync pattern.

PCM, on the other hand, has thousands of possible combinations of codes. There are several sync methods and combinations which may be used. These are word (channel) synchronization, frame synchronization, and subframe synchronization. (The ground station also must develop bit synchronization, that is, pulses which are coincident with each and every incoming data bit.) The data format determines which combinations of these sync methods may be used.

A word is usually made up of a number of bits (pulses). It is possible to reserve one to three more of these bits for synchronization purposes. In order to achieve word synchronization, the ground station must be able to detect the word sync bits for a number of consecutive words. These sync bits must fall into the proper bit positions every time before synchronization is assured. Because the word sync bits occupy a portion of the whole word, signal bandwidths over and above that required for only the data bits are necessary.

One word per frame is reserved for the purpose of frame synchronization. The code for this word is made unique so that the frame synchronizer at the ground station can distinguish it from the data words. The last word in each frame is the frame sync word. At the end of each frame, the recognition of the sync word causes the words per frame counter at the ground station to reset and thus prepare to count the words in the next frame.

The subdecommutation process counts the number of frames within the particular subframe so that a particular word within a particular frame can be located. Three principle methods of subframe identification are used; frame code complement, the recycling method, and the count-up/count-down or ID method.

In the frame code complement method, the last frame of the subframe is identified by the fact that the frame synchronization word in this frame is the complement (inversion) of the frame synchronization word in all the other frames.

In the recycling method, a subframe synchronizing code pattern is inserted somewhere within the last frame of the subframe. This code pattern may consist of a maximum of 64 bits located in up to eight different subcom channels.

The third method, the count-up/count-down or ID method, has a subframe sync code in which the frame identification number appears as a binary

number. The method is called count-up if the frames are identified in ascending numerical order, and count-down if the frames are identified in descending numerical order. With the ID method, any frame within a subframe can be identified almost immediately; whereas in the recycling method, or the frame code complement method, the subframe must be completed so as to acquire the unique word in the last frame.

### C. Comparison of Telemetry Techniques

Having been exposed to the basics of various telemetry systems and the problems of data transmission, we are now in a position to compare those systems to one another. Examination of their similarities and differences will demonstrate why PCM has become the predominate data transmission technique in telemetry.

Noise and bandwidth are the two basic limitations to the transmission of information. Thus, for any information carrying system the ultimate goal is to provide as large a signal-to-noise ratio and as narrow a bandwidth as possible. There is a relationship between the frequency and power spectrums of any signal. This signal may be either information or noise. This relationship says that as the bandwidth of the signal decreases, its total power decreases. Therefore, it is desirable to get as much signal power with as little noise power as possible. Obviously all that one has to do is decrease the bandwidth of the noise and/or increase the bandwidth of the information in order to obtain a high signal-to-noise ratio. However, this is not possible because the increase of bandwidth of one also increases the bandwidth of the other and vice versa. The only solution is a compromise. The question now is which system provides the best compromise: FM, PAM, PDM, or PCM?

Before these systems are compared, it is important to establish what we are trying to accomplish. The word telemetry implies that measurements are to be made. In making these measurements, the greatest precision consistent with the desired degree of accuracy possible must be obtained. Thus, the guiding principle in telemetry is precision. Imagine that a complex waveform is applied to an oscilloscope and the resultant trace on the CRT is obtained. This waveform has its peaks and valleys with finer variations along the way. If it is desired to measure the voltage of one of these variations, the amplification factor of the oscilloscope is increased to obtain a trace which is larger than the previous one. As the waveform is amplified more and more, the finer details may be measured with more and more precision.

Thus, each time the amplification (voltage swing) is doubled, the precision is doubled. If the information level is doubled in the presence of a fixed noise level, the signal-to-noise ratio is doubled.

To accomplish this in PAM, the pulse amplitudes must be doubled, which requires that the transmitter power to be squared. In FM and in PDM, the bandwidth must be doubled. In PCM, if we double the number of pulses transmitted we will double the bandwidth, however, instead of doubling the precision, it will be squared.

Page 10-24 shows that by the addition of only one pulse position, the number of quantization level is doubled. As another example, take the case of a four bit word and an eight bit word. The former provides 16 different quantization levels and the latter provides 256 quantization levels. The MSFN PCM decommutator can decommutate words up to 64 bits in length. This 64 bit word would provide  $17.4 \times 10^{18}$  or 17.4 quantillion (17,400,000,000,000,000,000) quantization levels.

It should be noted also that in PCM it is not necessary to transmit all channels with the same accuracy. If extreme accuracy is required in only one or two channels, these channels can be allowed to have several times the number of bits of the average channel, whereas in the other systems, all channels would have to be transmitted with the same degree of accuracy.

Severe noise combinations can alter the shape of PAM and PDM pulses so that the information contained in the amplitudes and widths would be changed. Even relatively mild noise levels can change these parameters sufficiently so that erroneous data is received. In PCM, however, all that needs to be detected is the presence or absence of a pulse. This can be readily done even under extremely low signal-to-noise conditions. The only condition that will cause an error to be received arises if the levels of the random noise pulses will cause a pulse to drop out or cause a pulse to appear when it should not. However, under such conditions, the signal-to-noise ratio is extremely low (about 6 db) and would make PAM and PDM data useless.

Although elaborate synchronization codes are required for PCM, this can also be turned to our advantage. Because they are elaborate, many synchronization codes can be used in the format, permitting the simultaneous operation of several different subcommutators (up to four in the MSFN decommutator).

#### D. Summary

Frequency division multiplex and time division multiplex are two means of transmitting large numbers of channels over a communications link. Of these, time division multiplex combined with electronic switching techniques can provide the most versatile system due to its ability to combine a larger number of channels with varied sampling rates. Of the time division multiplex techniques, PCM is probably the most versatile, most sensitive, most accurate, as well as the fastest. The MSFN PCM decommutator can handle data at up to 125,000 eight bit channels per second.

By way of comparison, Project Gemini uses the same capsule transmitter power, in the same bandwidth as Project Mercury, yet we are measuring over three times as many parameters at increased accuracy (better than 0.5% vs the 2% of Project Mercury) with more nearly optimum sampling rates, and essentially the same sensitivity.

In addition, because it is a digital system, and through the use of the on-site computer, more complete summary messages can be handled in a shorter period of time.



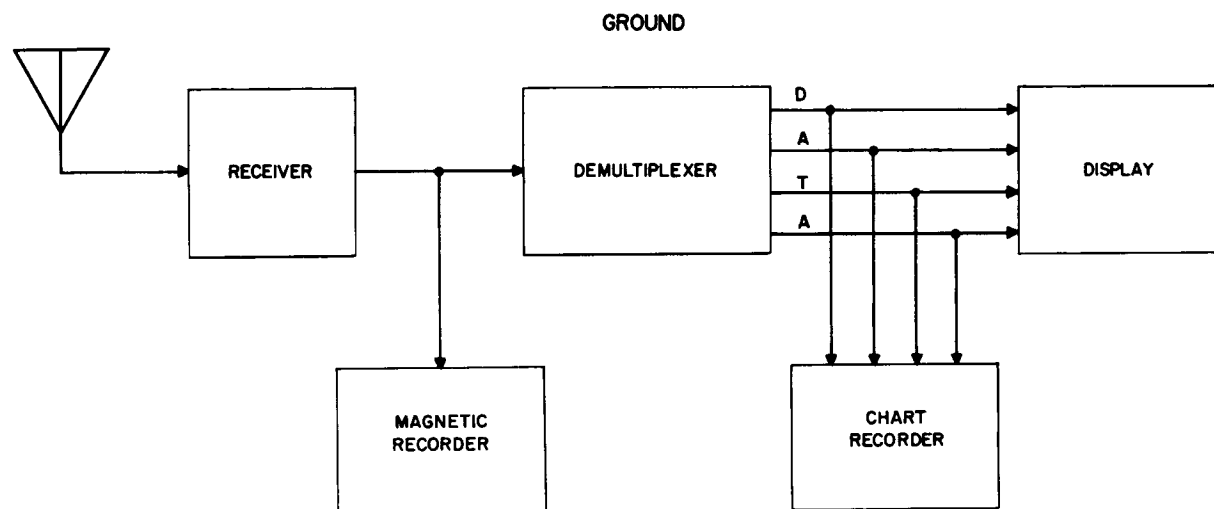
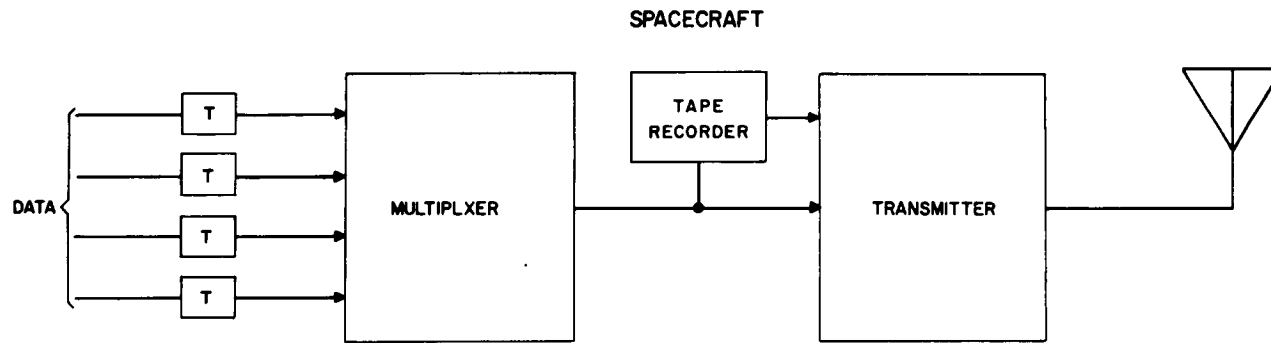

560004A

10-20

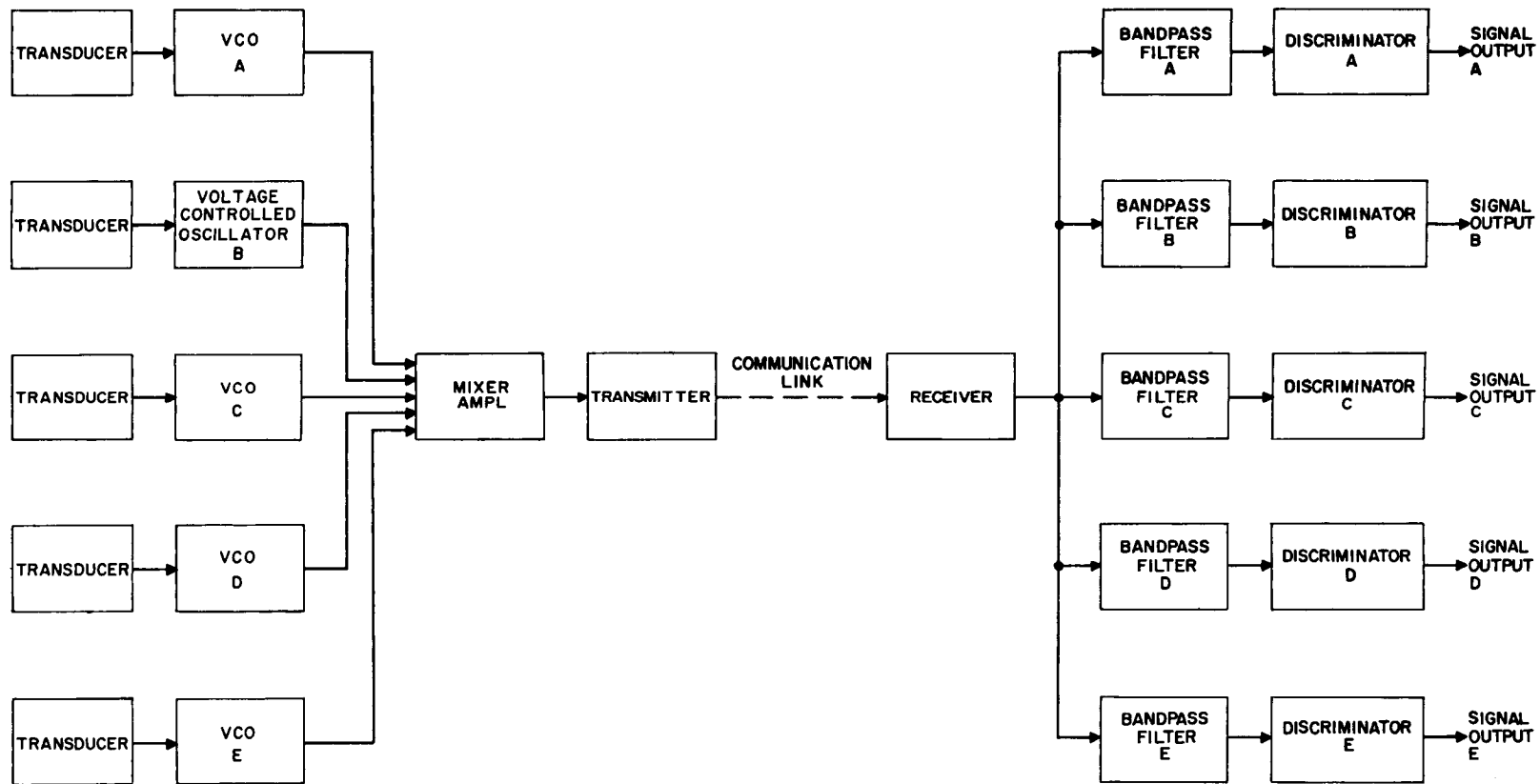

516005A

SPACECRAFT COMPONENTS

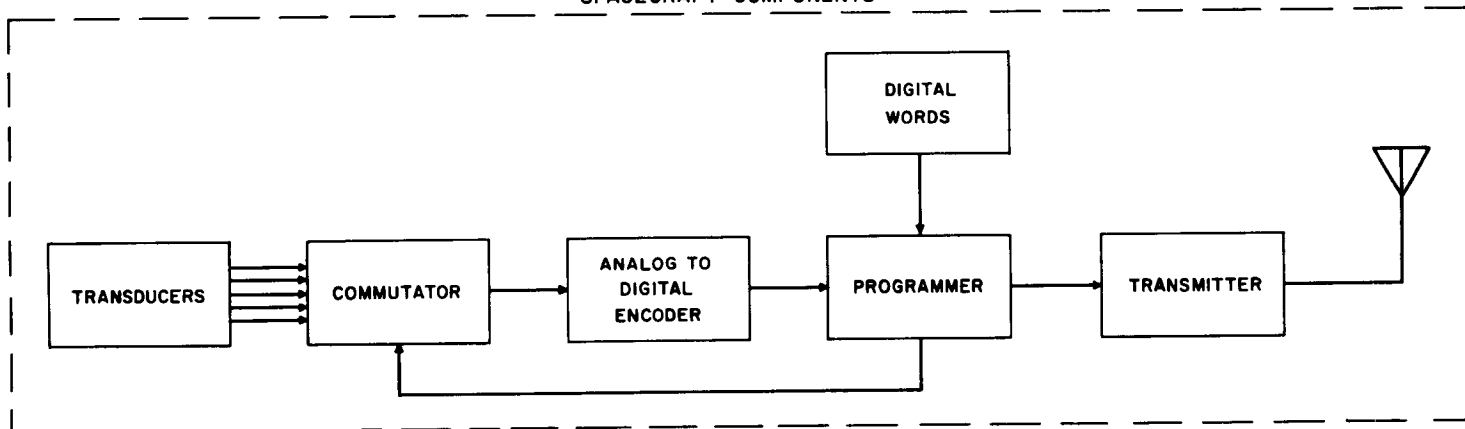

GROUND COMPONENTS

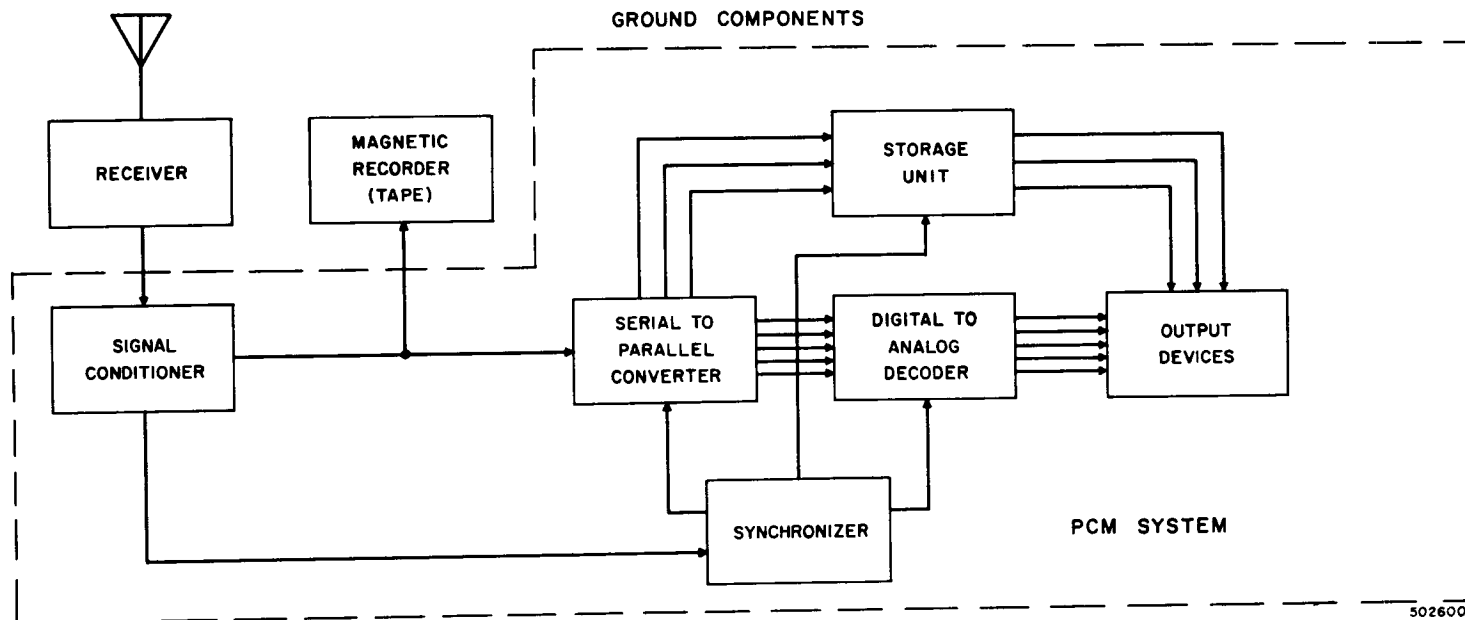

50260038

10-22



A. TIME VARYING SIGNAL:

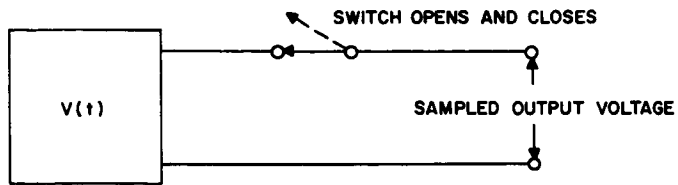

B. PERIODIC SAMPLER:

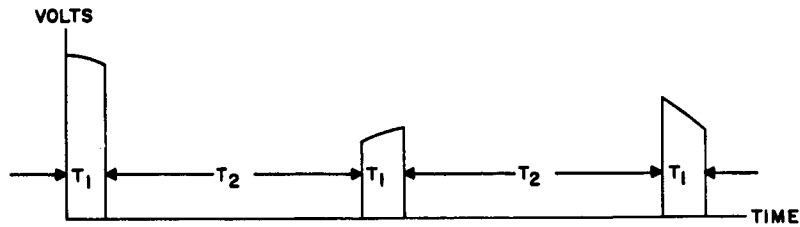

C. SLOW SAMPLING RATE:

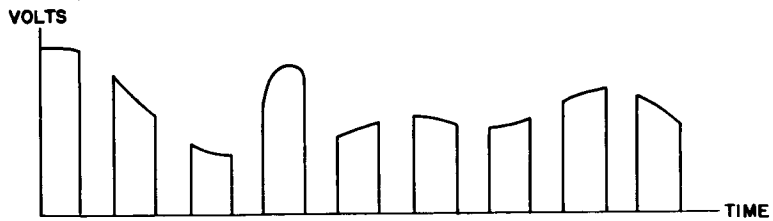

D. FAST SAMPLING RATE:

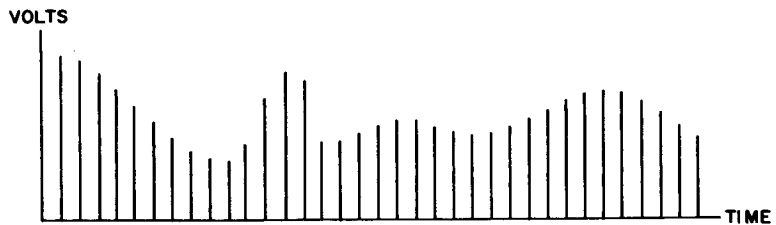

E. PULSE SAMPLING:

5160006A

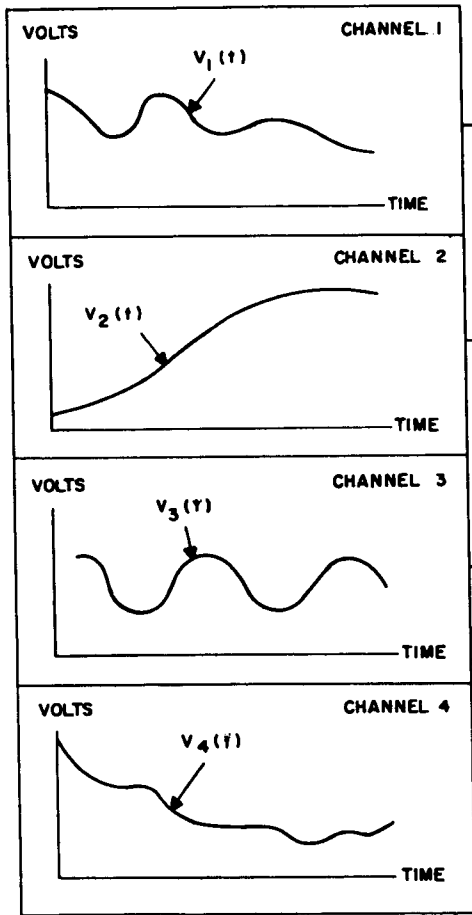

SIGNAL TO BE SAMPLED

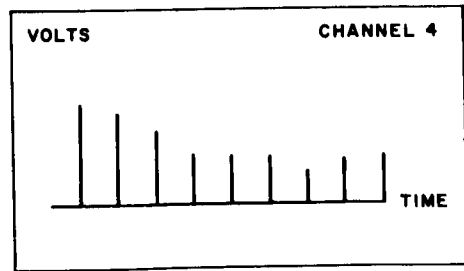
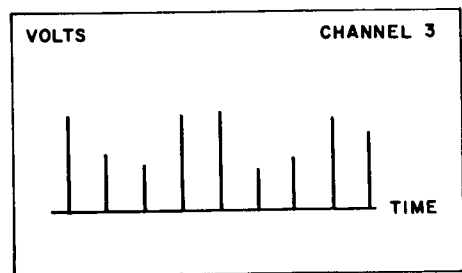
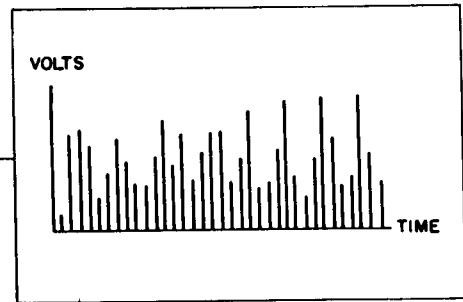
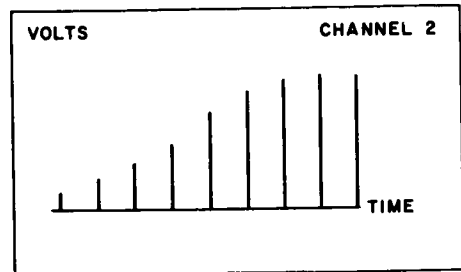
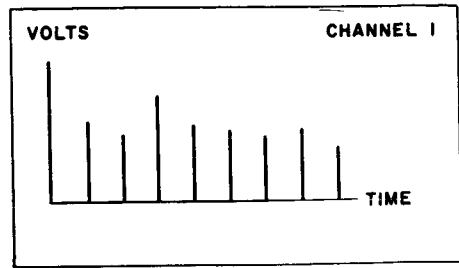
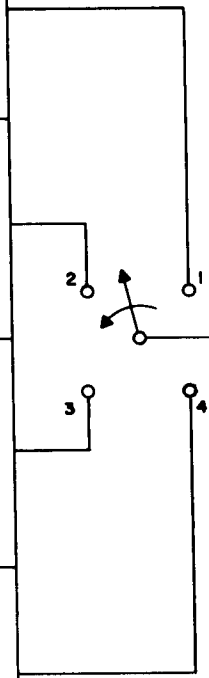

540007B

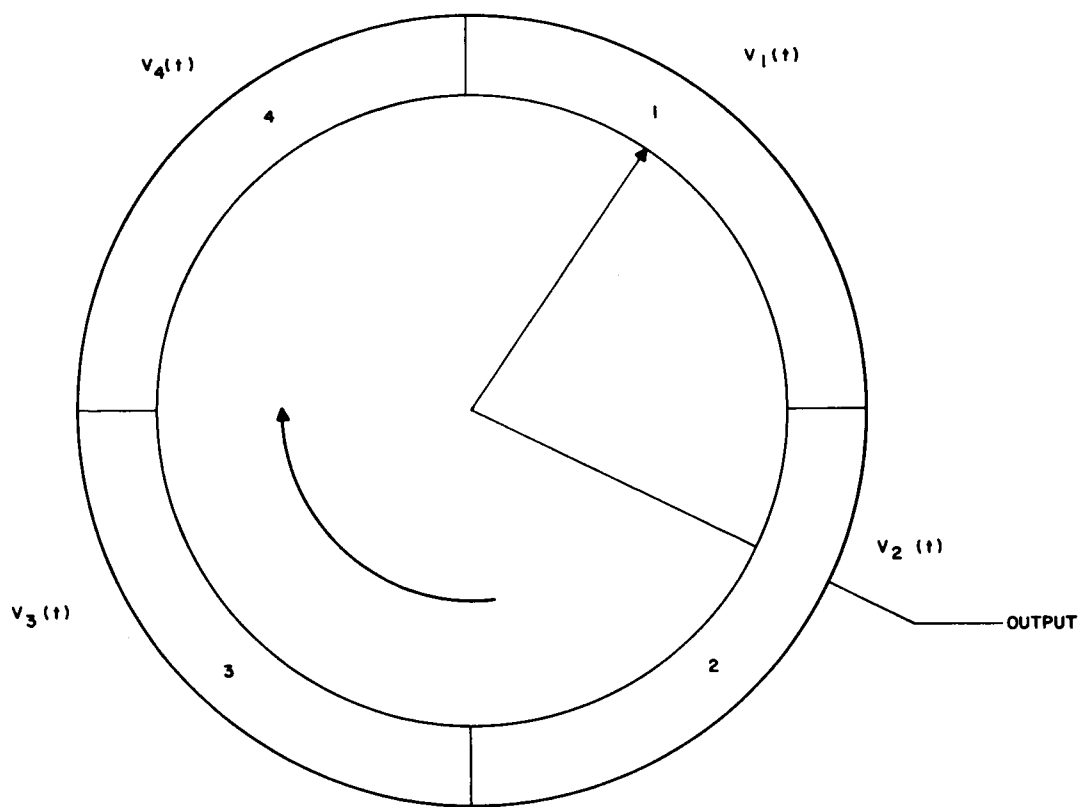

516 0009

SAMPLE RATE  
1 SAMPLE/S

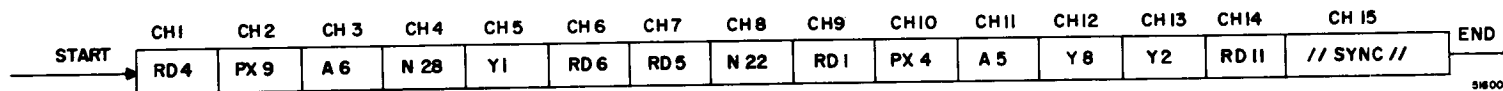
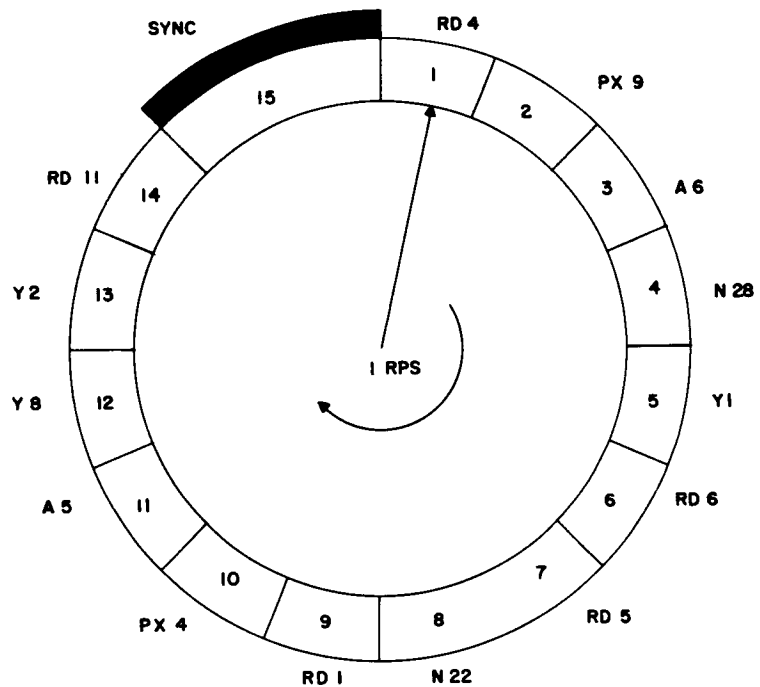

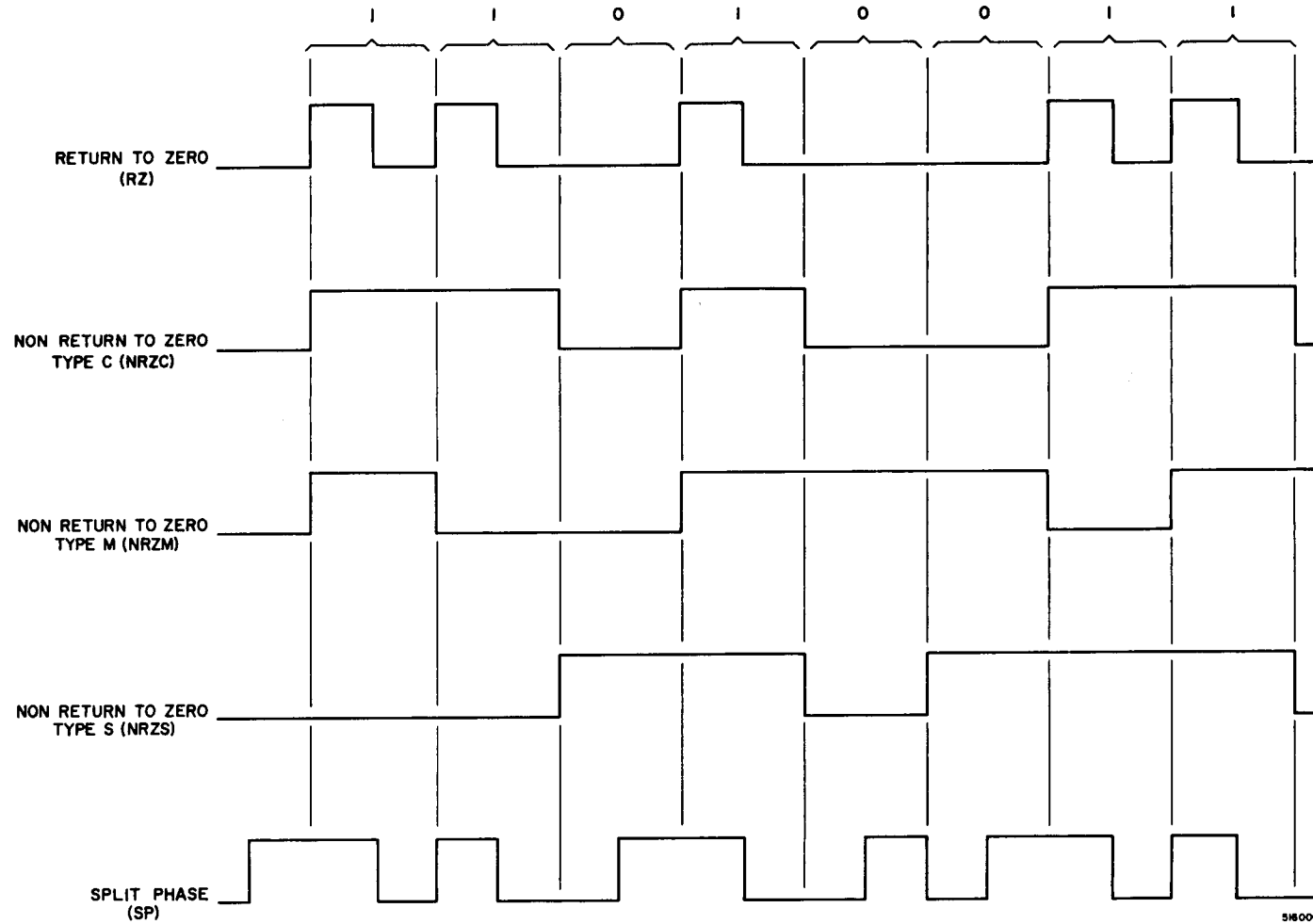



10-28

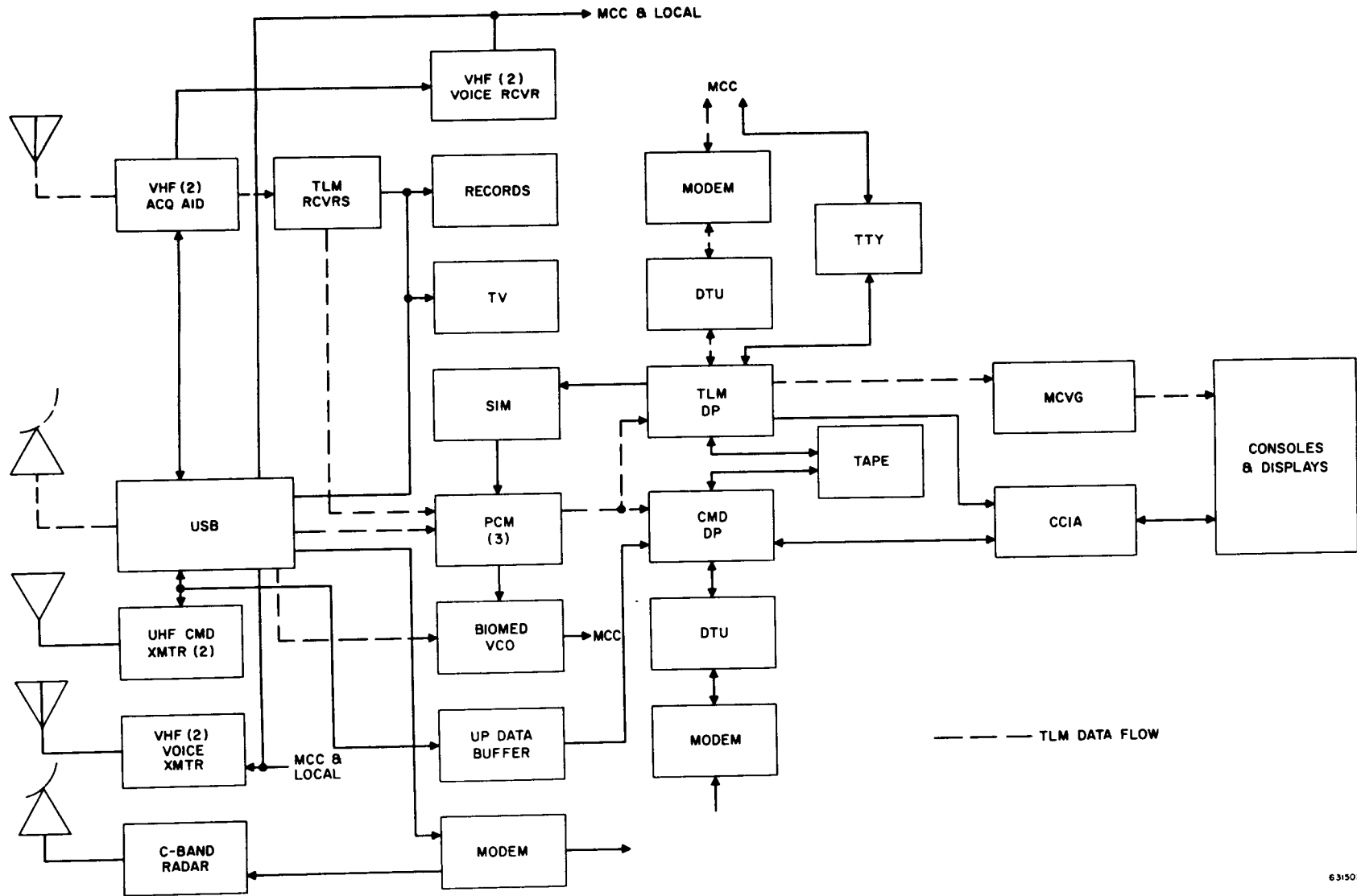

6315021

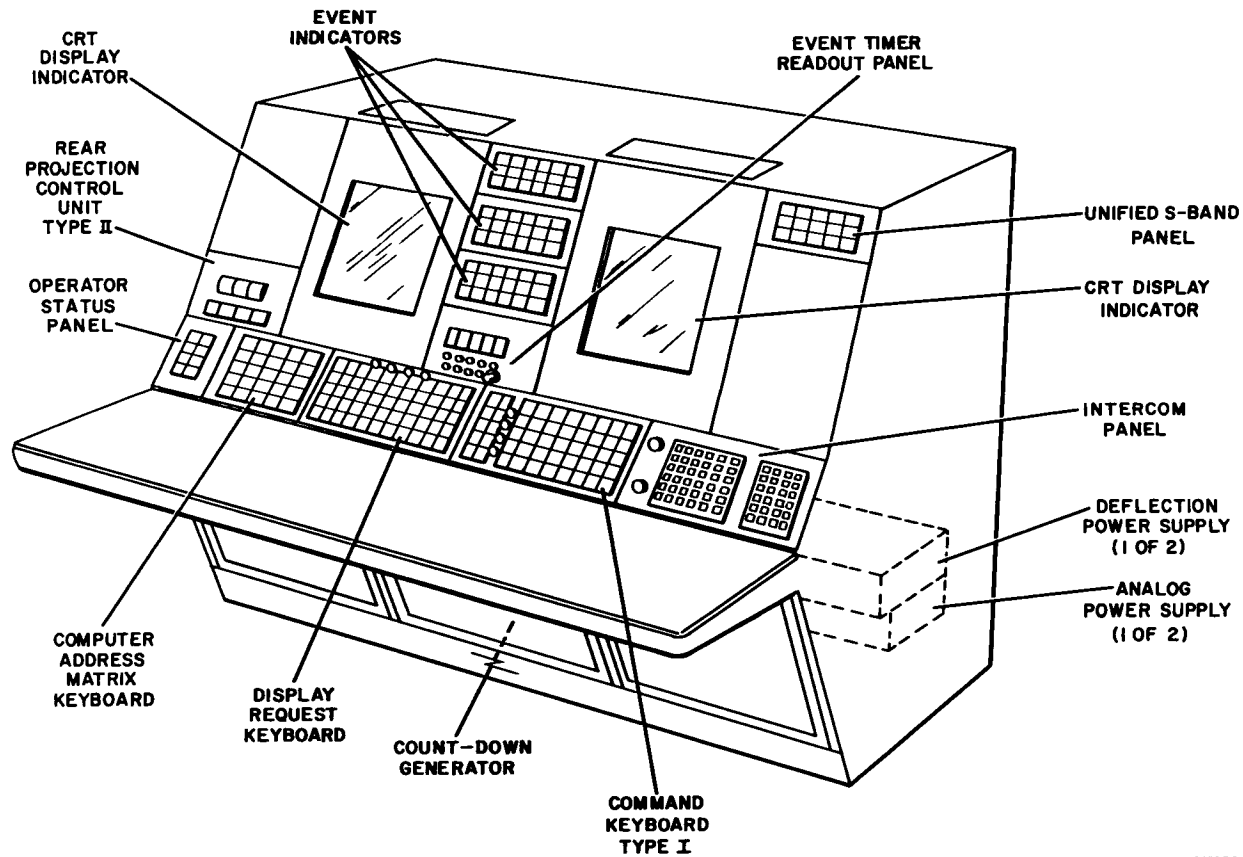

3556005

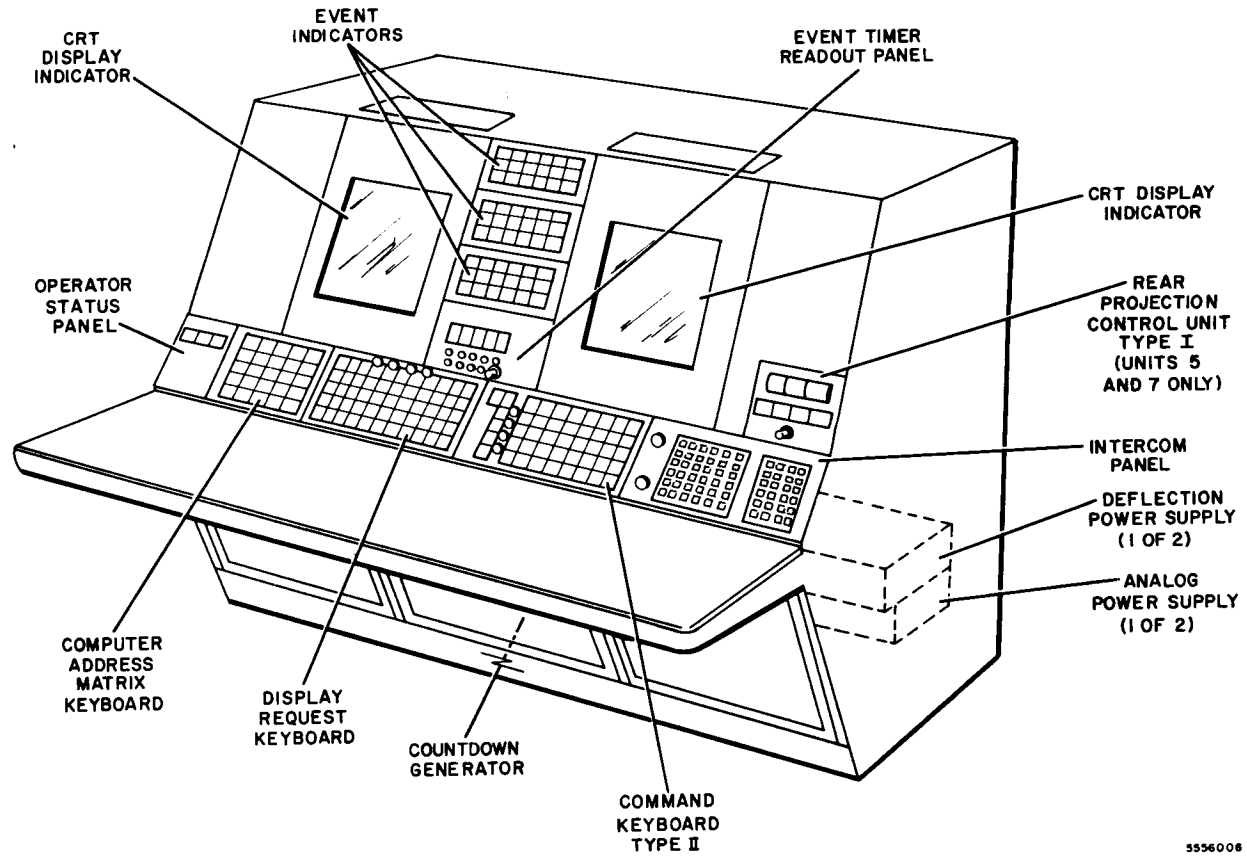

5556006

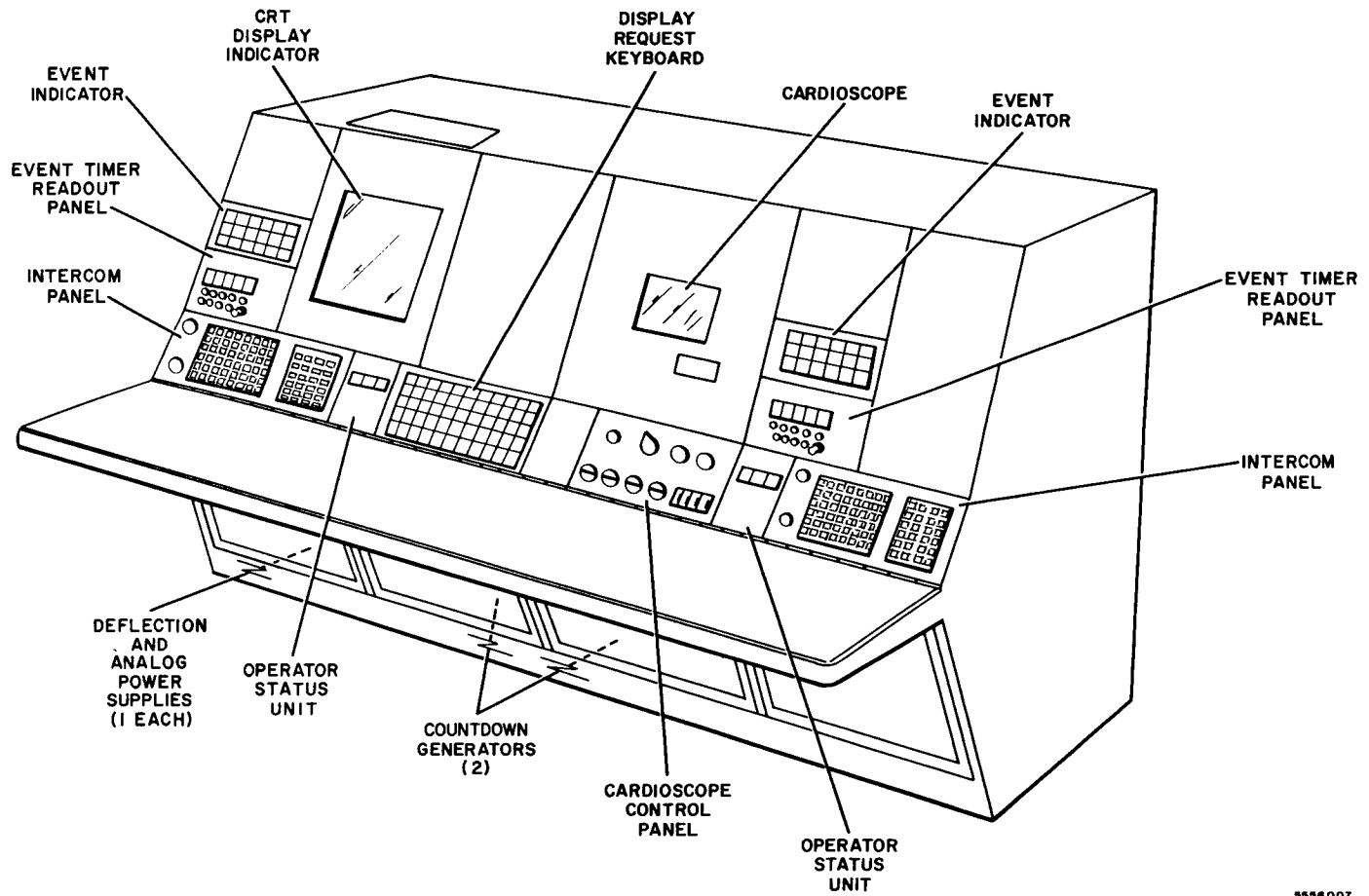

5556007

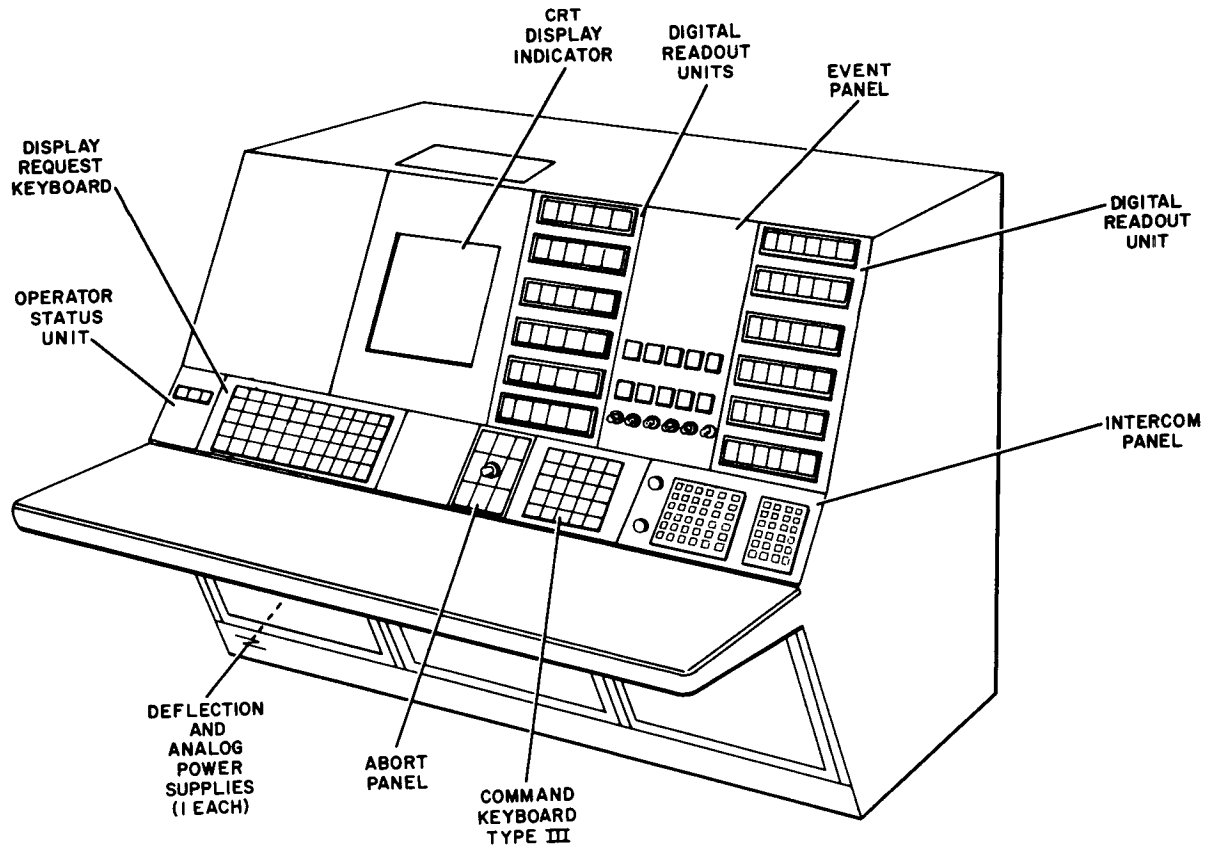

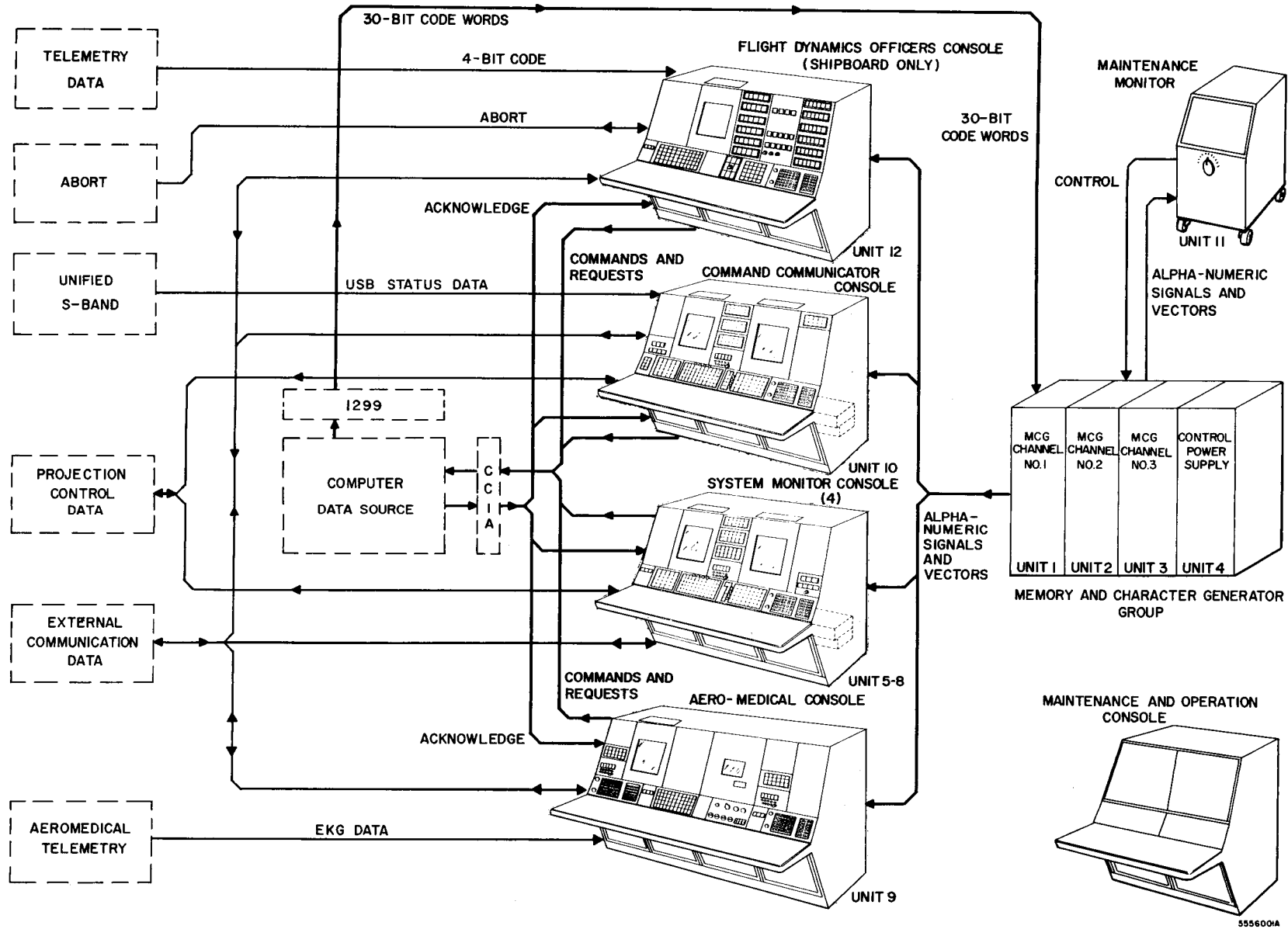

555600A

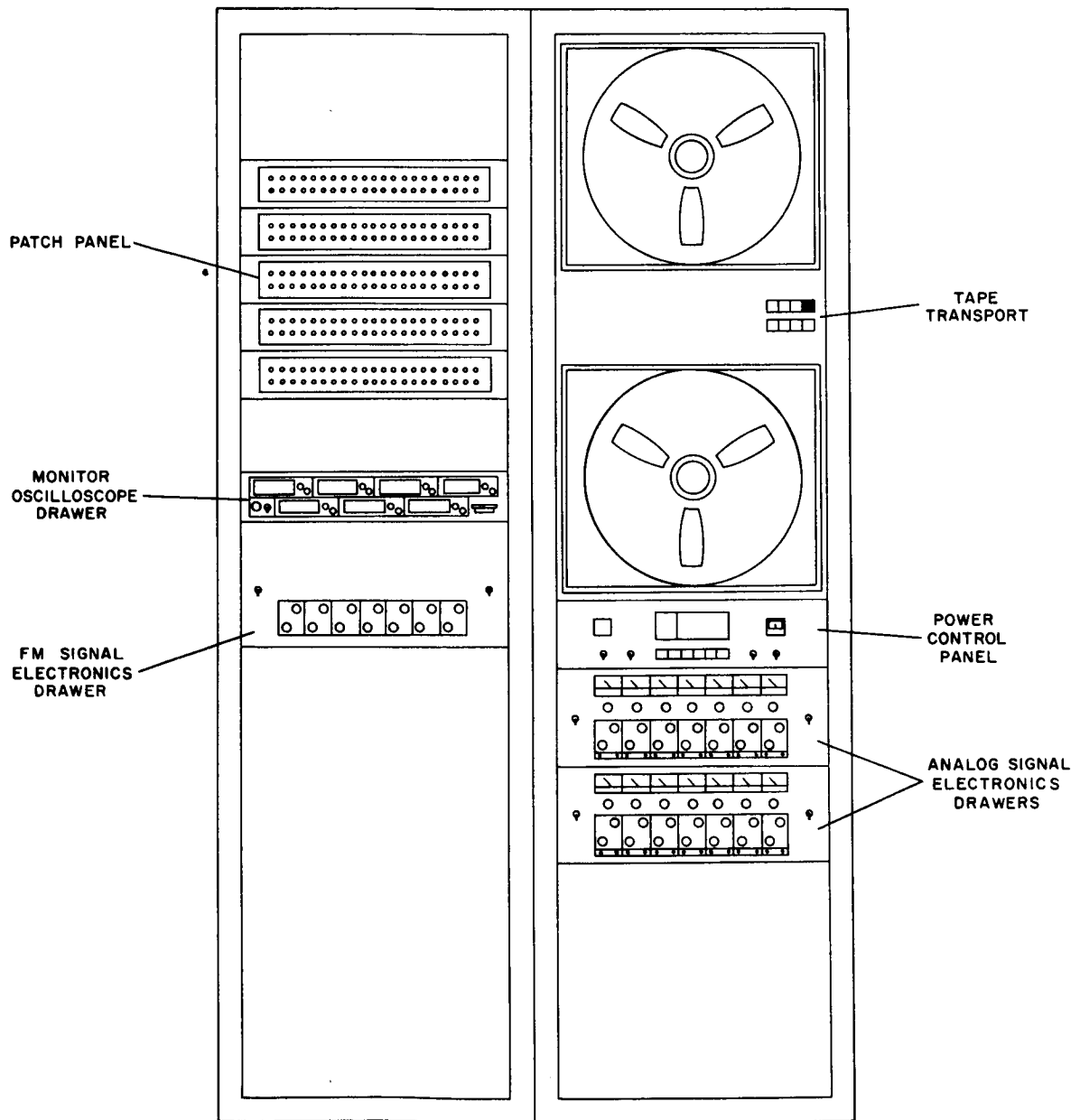

PATCH PANEL

MONITOR  
OSCILLOSCOPE  
DRAWER

FM SIGNAL  
ELECTRONICS  
DRAWER

TAPE  
TRANSPORT

POWER  
CONTROL  
PANEL

ANALOG SIGNAL  
ELECTRONICS  
DRAWERS

5680231

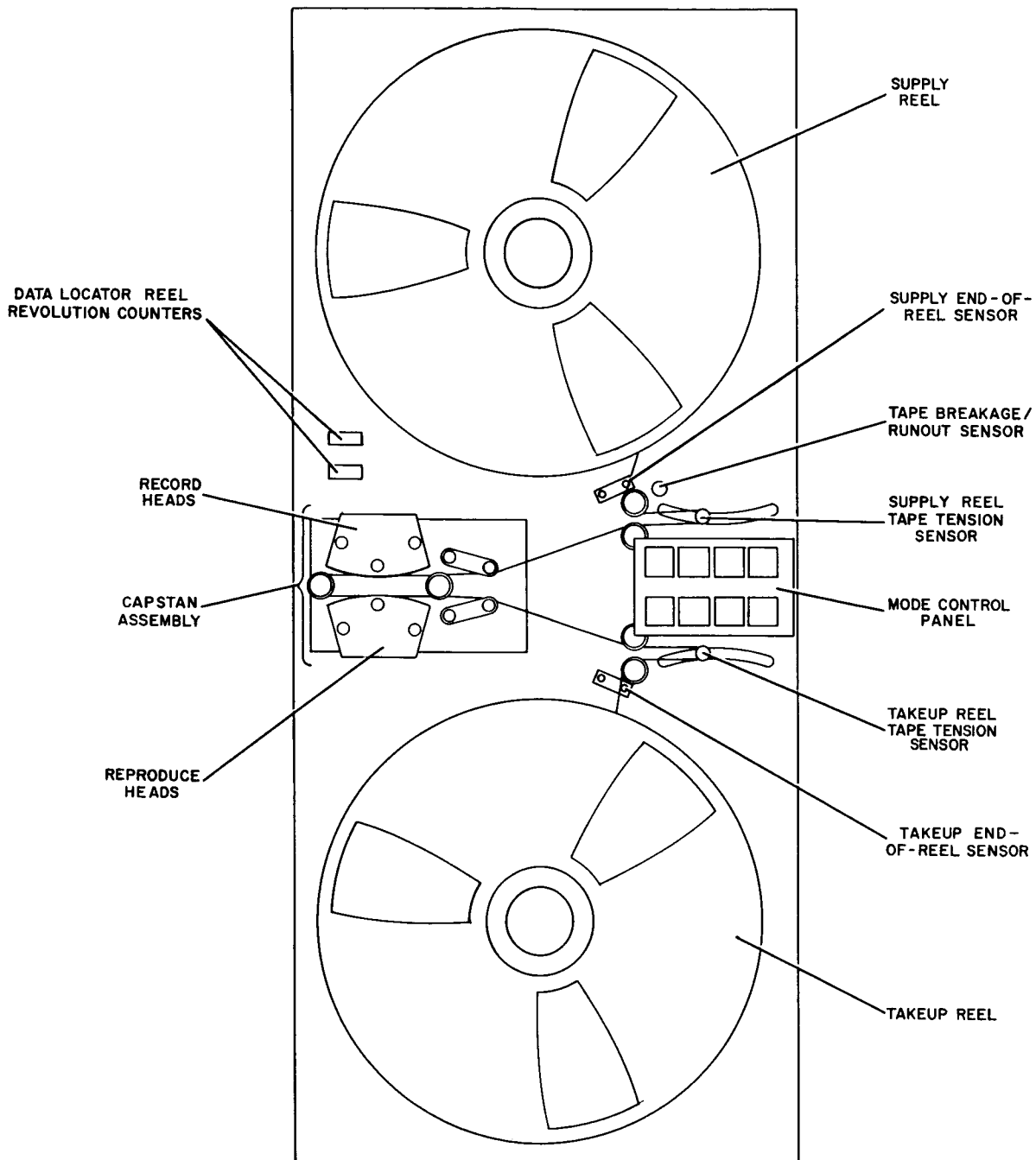

5680232



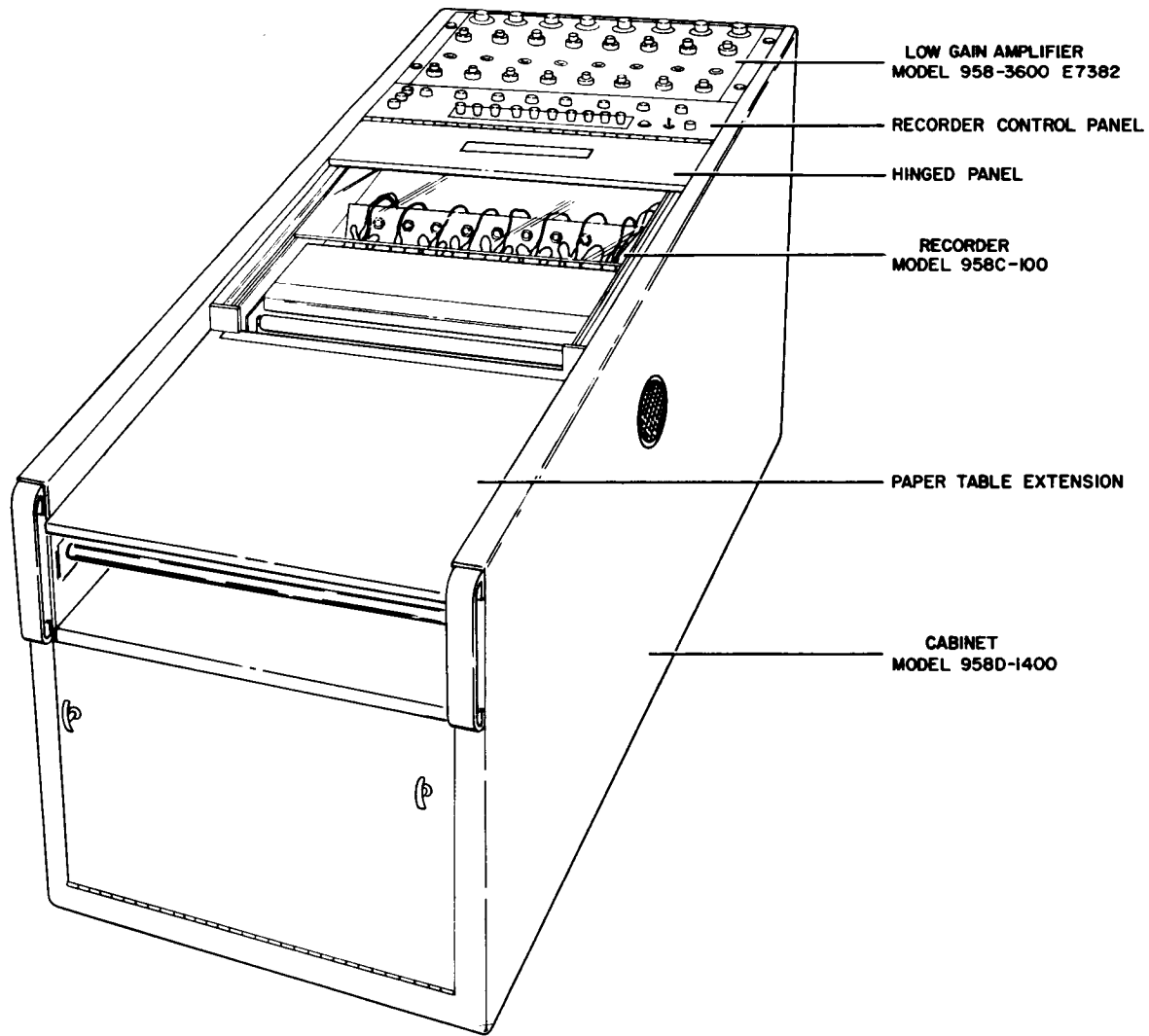

5815002

## SOLAR PARTICLE ALERT NETWORK SYSTEMS

### 1. OPTICAL AND RADIO TELESCOPE SYSTEM (SORT)

The Solar Particle Alert Network (SPAN) project is a joint effort of the National Aeronautics and Space Administration's Goddard Space Flight Center (GSFC) and Manned Spacecraft Center (MSC).

The purpose of SPAN is to determine the operational capability of a solar event warning network for the Apollo program which will provide advance radiation warning to astronauts by means of a radio and optical system, retrieving data in real time. These systems are installed and in operation at Carnarvon, Australia, Grand Canary Island, and MSC Houston, Texas.

The optical and RF data obtained by the SPAN is considered to be highly desirable for the successful conduct of Apollo operations for the following reasons:

- a. Without a solar flare proton warning system, the crew safety reliability for an Apollo mission is 0.99 with respect to radiation. This figure is too low considering that the overall Apollo system goal, excluding radiation, is 0.999.
- b. SPAN is capable of providing a radiation crew safety reliability of greater than 0.999 without decrease in the mission success reliability of 0.99. This reliability will be achieved by giving the flight director the warning required to send the lightly shielded Lunar Module (LM) back to the heavily shielded Command Module (CM) at the proper time.
- c. Without a solar flare proton warning system, 100 pounds of shielding would be necessary on the LM to provide the required reliability of 0.999. This shielding must be carried on all missions, even though only about one percent of the missions would encounter solar particle events large enough to require protection. The SPAN system, costing about \$2,000,000 through 1970, will provide the required 0.999 reliability without additional on-board equipment and weight.

### 2. JUPITER MONITOR

Although the sporadic emission of intense decameter radiation from the planet Jupiter has been studied by several workers every year since its discovery in 1955

no general theory of the emission mechanism has been accepted as completely satisfactory. Among the processes suggested to explain the origin of sporadic Jovian emission have been Cerenkov radiation, cyclotron radiation, synchrotron radiation and stimulated emission. This yet unresolved problem of the theory of the radiation mechanism at once reflects the need for further expanded observational data.

The radio bursts have been observed throughout the frequency range of 10 to 50-MHz but appear to be most frequent near 18 MHz. The duration of the bursts is on the order of one second, and they often occur in groups over a period of several minutes. The radiation is predominately right-hand elliptically polarized although it has occasionally been seen to switch from right-hand to left-hand polarization, and even back again to right-hand polarization in a matter of minutes.

A number of workers have studied the possible solar influence on sporadic emission from Jupiter and have noted at least a partial correlation between Jovian, solar, and geomagnetic activity. Warwick has reported a high rate of occurrence of Jupiter emission following solar radio continuum activity by 1 to 2 days for the 1960 apparition which suggests the influence of solar particles with velocities of the order of  $10^{-1}c$ .

The continuous observation of radio noise from Jupiter by a network of ground stations is a potentially effective tool for studying the earth's ionosphere and the interplanetary gas as well as the atmosphere of Jupiter. Recordings of the radio emission from the planet often show irregular amplitude scintillations not unlike those seen for the low frequency radiation of cosmic radio sources. Often the fluctuations recorded by different observing stations appear to possess little or no correlation and are therefore thought to be due to ionospheric irregularities as in the case of "radio star" scintillations.

The Jupiter monitor system can perform the functions of three monitor systems. These functions are:

- a. Jupiter Monitor - Monitor the planet Jupiter at the frequencies of 16.6 and 22.2 Mcs.
- b. Radiometer - Monitor the solar disc at the frequency of 2695 MHz.
- c. RIOMETER (Relative Ionospheric Opacity Meter) - Monitor the Earth's ionosphere at the frequencies of 30 and 50 MHz.

### 3. RIOMETER (Relative Ionospheric Opacity Meter)

The riometer is used to precisely measure changes in ionospheric absorption of extraterrestrial radio noise. Such changes are caused by variations in electron density within the ionosphere which can be brought about by solar atmospheric disturbances. These disturbances may be caused by solar phenomena or they may be man made.

The riometer operates by comparing the antenna signal with a local source of noise, providing a detected output which is a voltage proportional to the difference between the two signals and using this voltage output (error voltage) to control the noise diode filament current in such a way as to equate its noise output to that of antenna noise. This advanced measuring technique eliminates the effects of gain instability common to most electronic measuring devices. Once set, the riometer can be relied on for precise data on a day-to-day, year-to-year basis.

This system continuously monitors the frequencies of 30 and 50 Mcs.

12-4

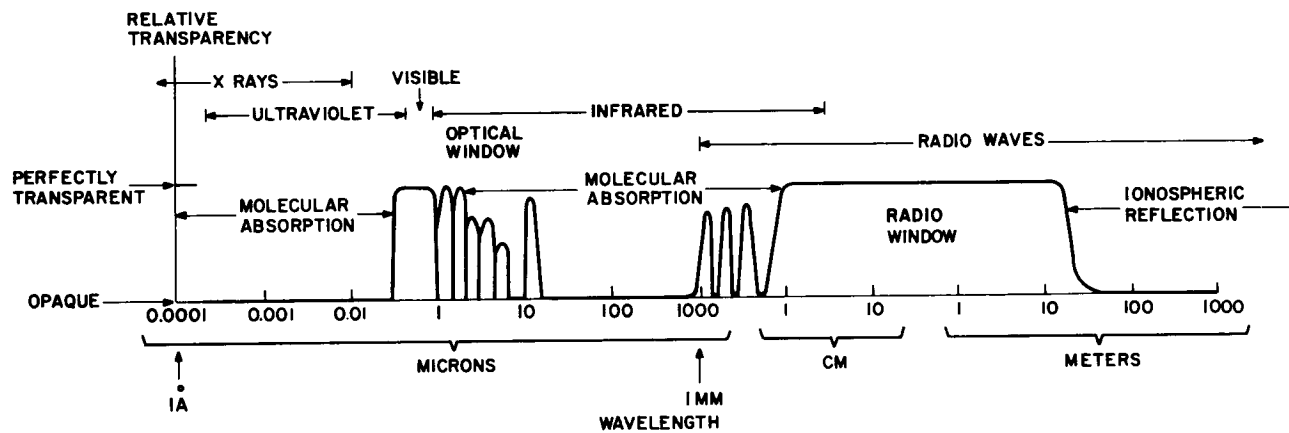

5 6 6 0 2 9 5

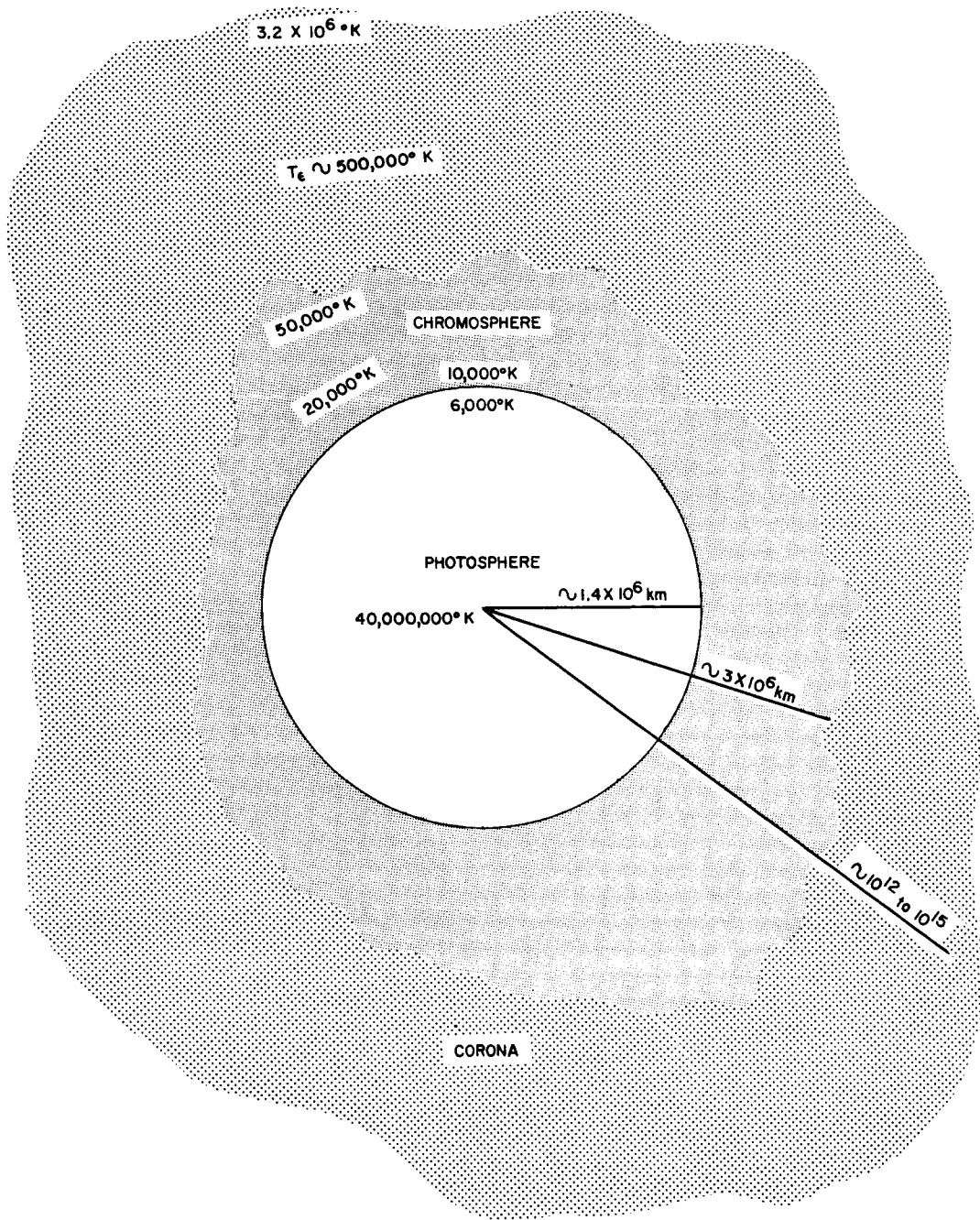

5680296

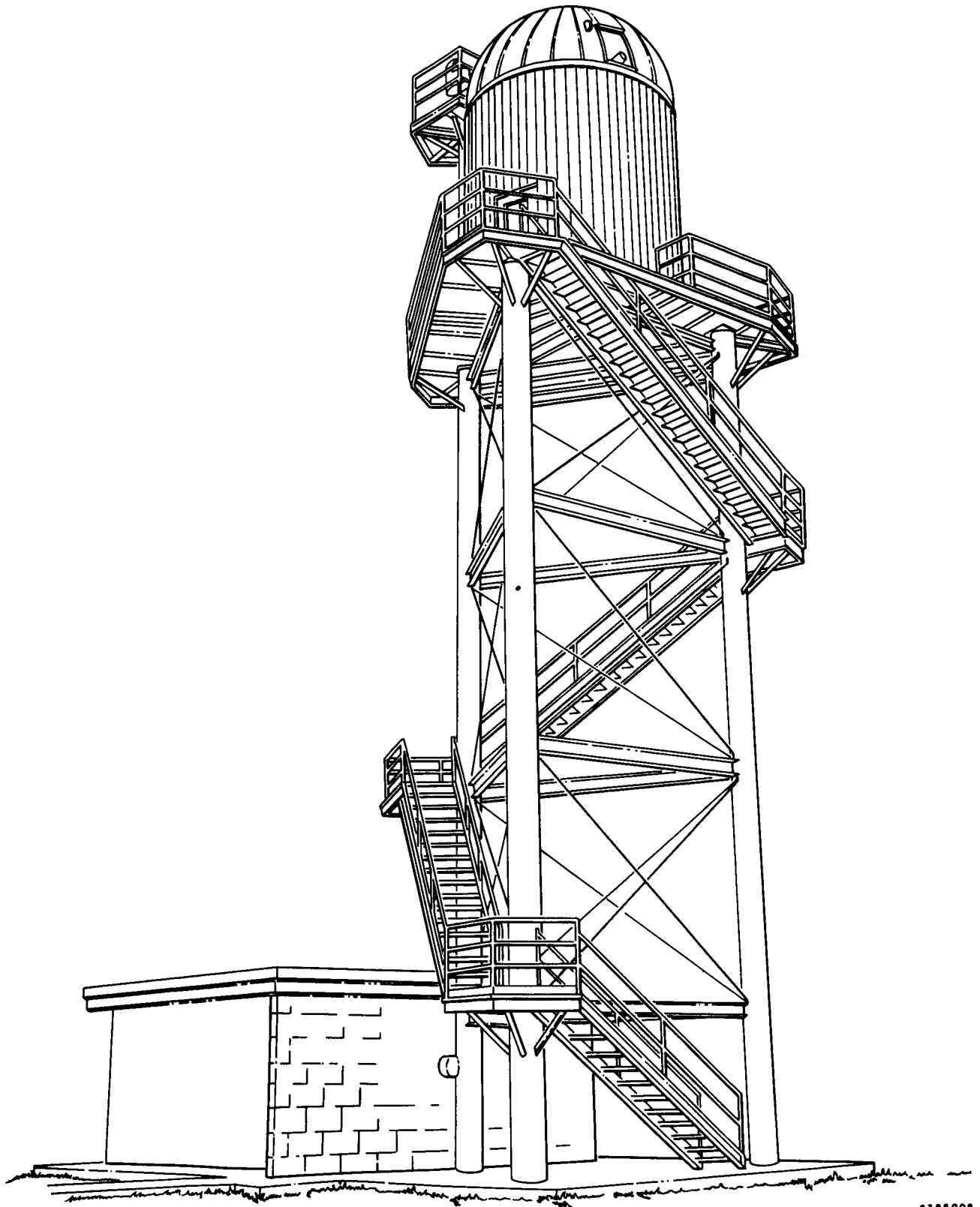

638508

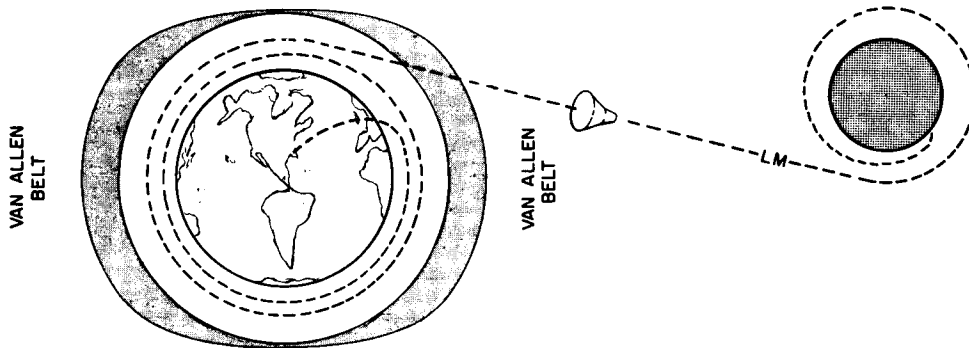
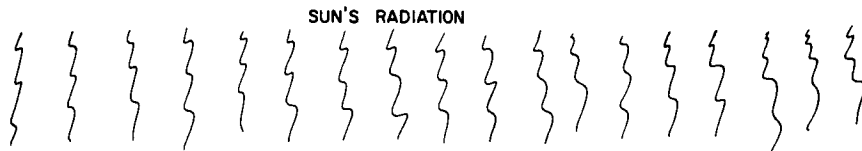

5880299



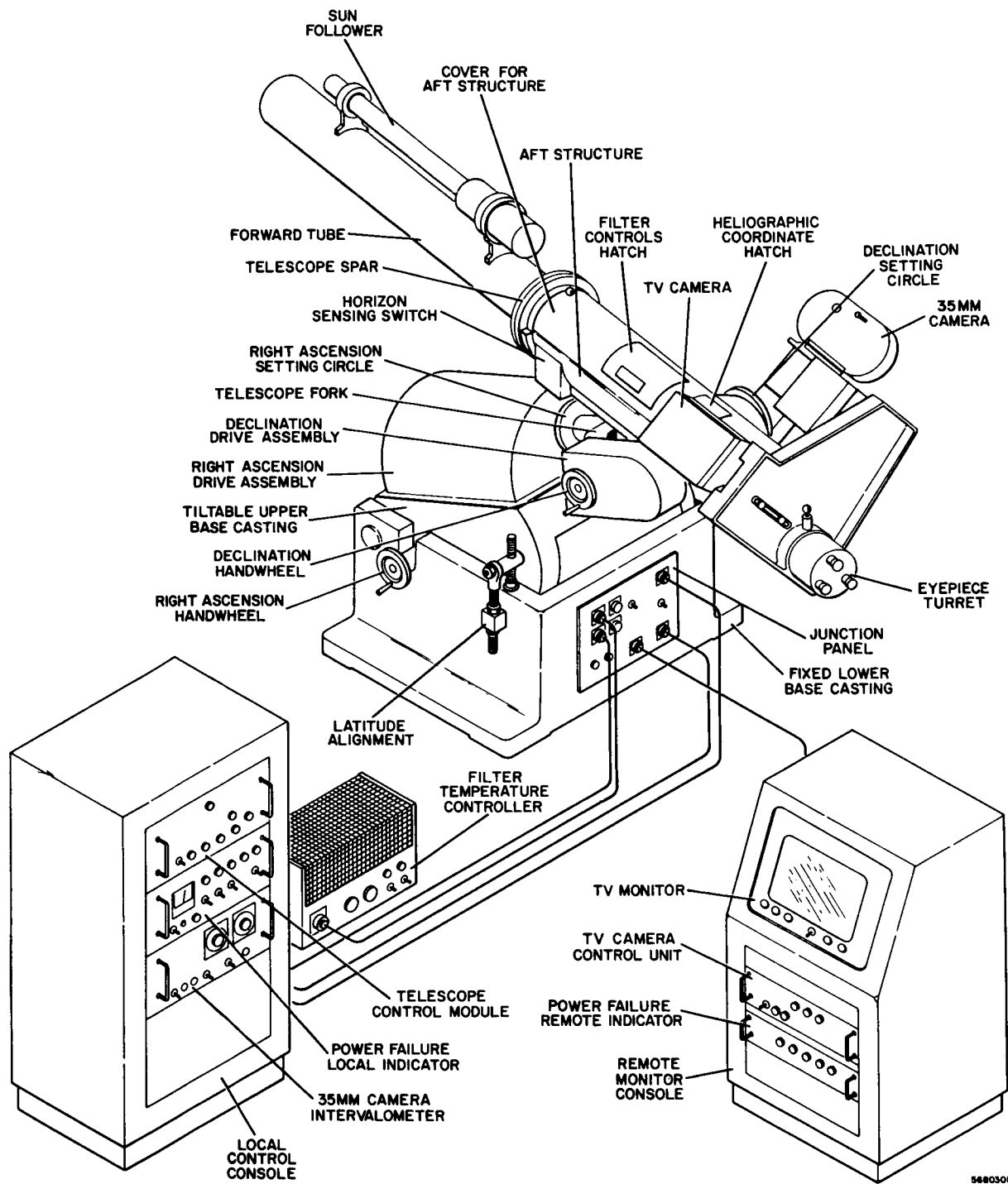

56#0301

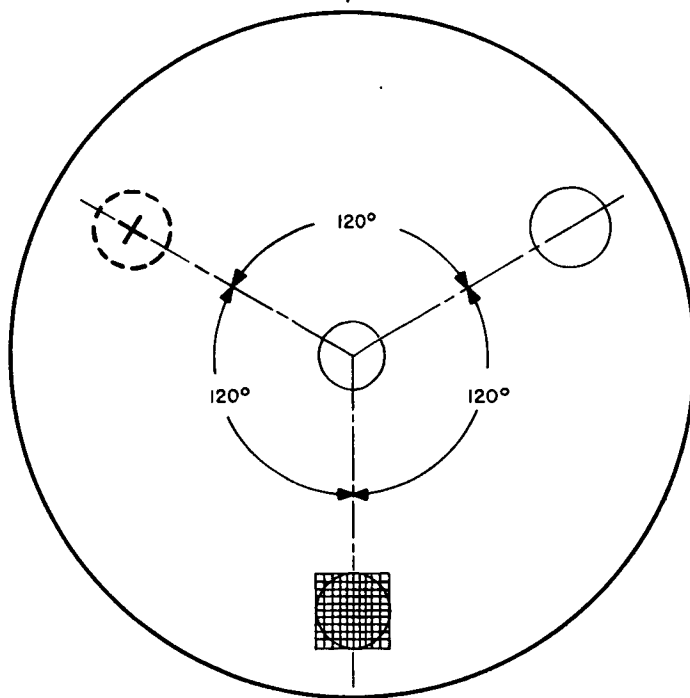
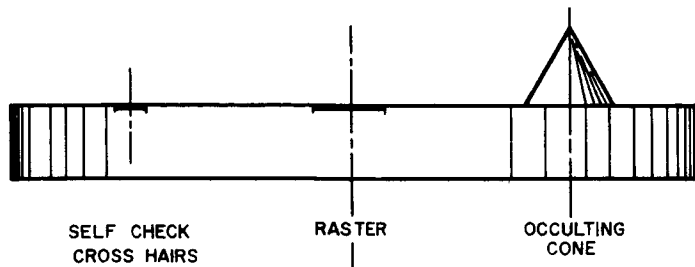

ENLARGED VIEW  
OF RASTER

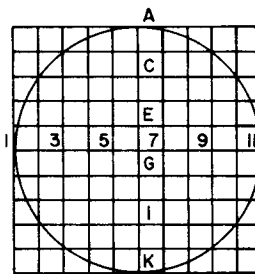

5680302

12-10

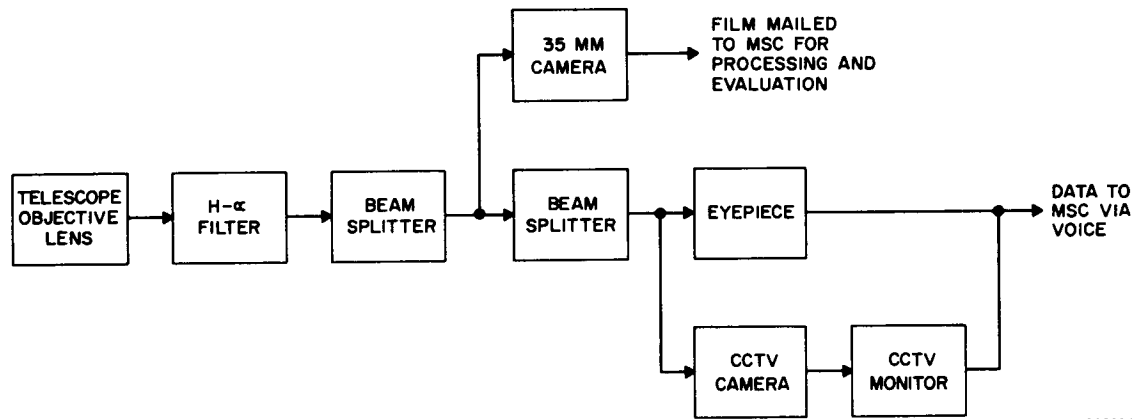

5680300A

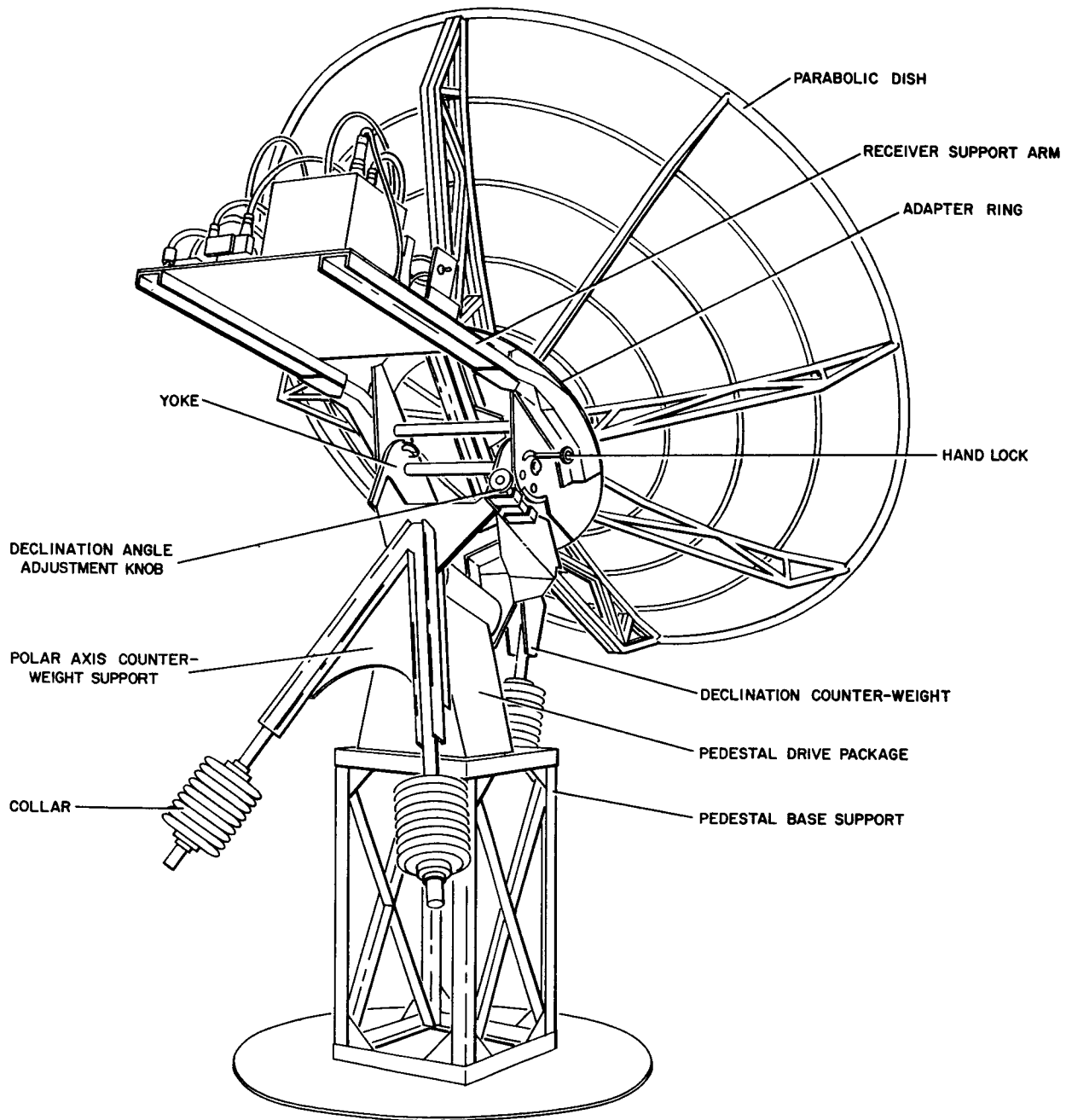

5680306

12-12

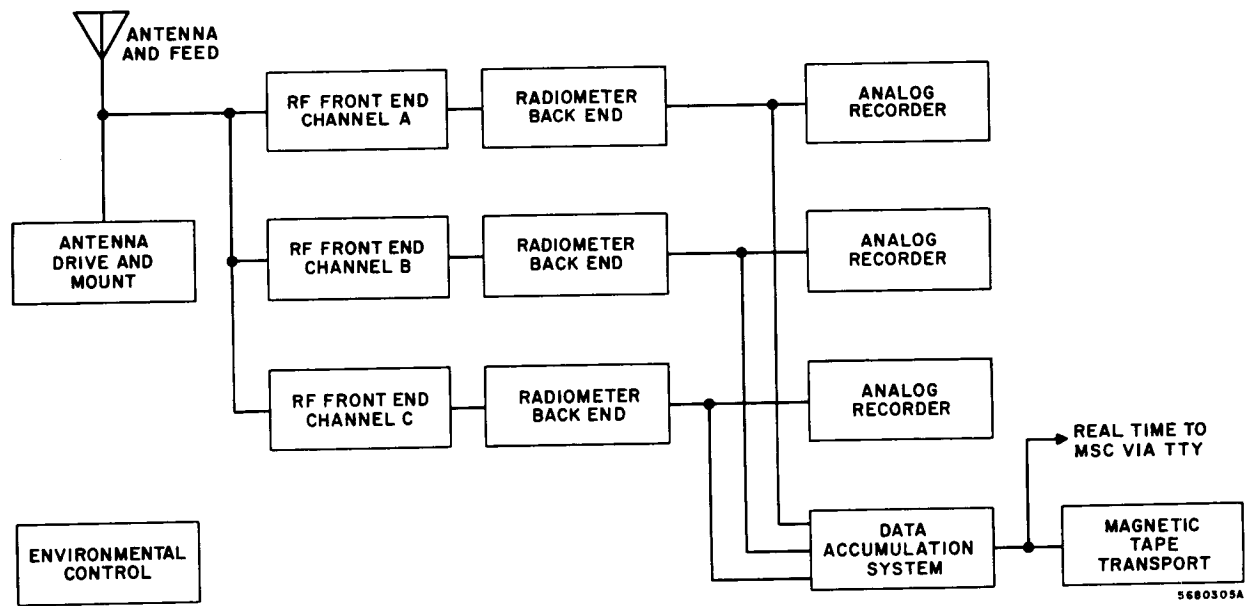

## APOLLO SOLAR TERMINOLOGY

AERONOMY	The study of the atmosphere, especially its relation to the Earth and the effect upon it of bombardment by radiation from space.
ANGSTROM	A unit of length, used chiefly in expressing short wavelengths. Ten billion angstroms equal one meter.
CHROMOSPHERE	One of the atmospheric shells of the Sun, lying above the Photosphere and best visible at time of total eclipse. Can be observed spectroscopically at other times.
CORONA	The faintly luminous outer envelope of the sun. Also called solar corona.
CORONAGRAPH	Device to scan and record the solar corona.
COSMIC DUST	Small meteoroids of a size similar to dust.
COSMIC RAYS	The extremely-high-energy subatomic particles which bombard the atmosphere from outer space. On colliding with atmospheric particles they produce many different kinds of lower-energy secondary cosmic radiation.
DECLINATION	Angular distance north or south of the celestial equator. The arc of an hour circle between the celestial equator and a point on the celestial sphere, measured through 90 degrees, and labeled N or S to indicate the direction of measurement.
ECLIPTIC	Plane of the earth's orbit around the sun. Used as a reference plane for other interplanetary orbits.
ECLIPTIC PLANE	The plane of the earth's motion about the sun.
ELECTROMAGNETIC RADIATION	Energy propagated through space or through material media in the form of an advancing disturbance in electrical and magnetic fields existing in space or in the media. Also called simply radiation.
ELECTROMAGNETIC SPECTRUM	A collective term for all known radiation from the shortest-waved gamma rays through x-rays, ultraviolet, visible light, infrared waves, to radio waves.

ELECTROMAGNETIC WAVE	Form in which radiant energy travels, produced by oscillation of an electric charge, and including waves of radio, infrared, visible light, ultra-violet light, x-rays, gamma rays, and cosmic rays when considered as quanta of energy.
ELECTRON	The subatomic particle that possesses the smallest possible electric charge.
ENERGETIC PARTICLE	An electron, positron, neutron, or other elementary particles of matter traveling at extremely high speeds. Such particles originate in outer space or from the Sun and lose their energy in the atmosphere.
EPHERMERIS	Book of tables giving daily positions of celestial bodies.
EQUATORIAL ORBIT	An orbit in the plane of the Earth's equator.
FISSION	The release of nuclear energy through splitting of atoms.
FISSION FRAGMENT PHYSICS	The study of the behavior of the high energy particles resulting from a nuclear fission reaction.
FLARE (SUN)	A bright eruption from the Sun's chromosphere. See solar flare.
GALACTIC ASTRONOMY	The study of the galaxies and their components.
GALACTIC COSMIC RAYS	Cosmic rays that do not originate in the sun are referred to as galactic cosmic rays and are those of the greatest energy.
GAMMA RADIATION	Electromagnetic radiation, similar to x-rays, originating from the nucleus of an atom and having a high degree of penetration.
GAMMA RAY	An electromagnetic radiation or waveform emitted by a radioactive nucleus and similar to x-rays but of higher energy and shorter wavelength.
GEOHYDROMAGNETICS	The study of the upper atmosphere and radiation belts that surround the Earth, and their interactions with charged particles streaming from the Sun's and Earth's magnetic field.
GEOMAGNETIC FIELD	The magnetic-field of force surrounding the Earth.

GEOMAGNETISM	The magnetic-phenomena, collectively considered, exhibited by the Earth and its atmosphere. The magnetic phenomena in interplanetary space.
GEOPHYSICS	The physics of Earth and its environment.
HEAVISIDE LAYER	Region of the ionosphere that reflects radio waves back to earth. Also called kennely-heaviside layer.
HEAVE COSMIC RAY PRIMARIES	Positively charged nuclei of elements heavier than hydrogen and helium up to, but not including, atomic nuclei of iron. Comprising about one percent of the total cosmic ray particles.
HELIOCENTRIC	Measured from the center of the Sun. Related to, or having the Sun as a center.
HETEROSPHERE	That part of the upper atmosphere wherein the relative proportions of oxygen, nitrogen, and other gases are unfixed and wherein radiation particles and micro-meteriods are mixed with air particles.
HIGH-ENERGY RADIATION	Penetrating particles or electromagnetic radiation of more than a few thousand electron volts, including electrons, neutrons, protons, means x-rays and gamma rays.
HOMOSPHERE	That part of the atmosphere made up of atoms and molecules found near the Earth's surface and retaining the same relative portions of oxygen, nitrogen, and other gases.
INCIDENT RADIATION	Radiant energy impinging on a surface per-unit-time and per-unit-area. Also called irradiation or flux density.
INFRARED	Electromagnetic radiation in the wavelength interval from the red end of the visible spectrum on the lower limit to microwaves used in radar on the upper limit.
INFRARED LIGHT	Light in which the rays lie just below the red end of the visible spectrum.
INTERNATIONAL QUIET SUN YEAR - IQSY	In 1965, solar flares and disturbances were at a periodic low level, during which scientists throughout the world cooperatively engaged in the study of the Sun.
INTERPLANETARY	Between planets.



INTERPLANETARY MONITORING PROBE - IMP	Designed to provide detailed measurement of the radiation environment between Earth and Moon. Characteristics of particle fluxes from the Sun, the interplanetary magnetic field, and solar-terrestrial relationship will be studied.
IONIZE	Change to ions, become electrically charged, as a gas under the influence of heat, electron bombardment, and nuclear radiation.
IONIZED LAYERS	Layers of increased ionization within the ionosphere. Responsible for absorption and reflection of radio waves and important in connection with communication and the tracking of satellites and other space vehicles.
IONOSPHERE	An outer belt of the Earth's atmosphere in which radiations from the Sun ionize, or excite electrically, the atoms and molecules of the atmospheric gases.
MAGNETIC MERIDIAN	A great circle of the Earth passing through the magnetic poles.
MAGNETIC STORM	A worldwide disturbance of the Earth's magnetic field.
MESOSPHERE	In the nomenclature of Chapman, a stratum of atmosphere that lies between the stratosphere and the ionosphere, sometimes called the chemosphere. In the nomenclature of Wares, a stratum that extends approximately from 250 to 600 miles, lying between the ionosphere and the exosphere.
METEOR	A transient celestial body that enters the Earth's atmosphere with great velocity, incandescent with heat generated by the resistance of the air.
METEOR SAFE WALL	A protective blanket of atmosphere through which meteors rarely penetrate. Meteors are burned up and vaporized in this area due to friction with air molecules.
METEORIC	Of or pertaining to meteors, or meteoroids.
METEORITE	A meteoroid which has reached the surface of the Earth without being completely vaporized.
METEOROID	A small solid body traveling through outer space. When a meteoroid enters the Earth's atmosphere it becomes a meteor.

MICROMETEOROID	Meteoroids less than 1/250th of an inch in diameter.
MICROMETEORITE	A very small meteorite or meteoritic particle with a diameter less than a millimeter.
OCCULTATION	The disappearance of a body behind another body of larger apparent size.
ORBITING ASTRONOMICAL OBSERVATORY - OAO	A series of scientific satellites to obtain precision telescopic observation of emission and absorption characteristics of the Sun, stars, planets, and nebulae in the ultraviolet, infrared, and X-ray regions of the electromagnetic spectrum.
ORBITING SOLAR OBSERVATORY - OSO	A solar-stabilized scientific satellite carrying solar-oriented experiments, comparing radiation from the sun to that in other portions of the sky. First launch was in 1962.
OZONOSPHERE	A stratum in the upper atmosphere having a relatively high concentration of ozone, important for absorption of ultraviolet solar radiation.
PHOTOSPHERE	The outermost luminous layer of the Sun's gaseous body.
PLAGES	Clouds of calcium or hydrogen vapor that show up as bright patches on the visible surface of the sun.
PLANET	A celestial body of the solar system revolving around the sun in a nearly circular orbit, or similar body revolving around a star.
PLANETOID	One of the numerous small planets nearly all of whose orbits lie between Mars and Jupiter. Also called asteroid and minor planet.
PLANETOLOGY	The study of planets and satellites.
PRIMARY COSMIC RAYS	High-energy particles originating outside the earth's atmosphere.
PROPAGATION	Describes the manner in which an electromagnetic wave such as a radar signal, timing signal, or ray of light, travels from one point to another.
PROTON	A positively charged subatomic particle of a positive charge equal to the negative charge of the electron but of 1827 times the mass. A constituent of all atomic nuclei. See - solar protons.

RADAR ASTRONOMY	The study of celestial bodies within the solar system by means of radiation originating on Earth but reflected from the body under observation. See - radio astronomy
RADIAL VELOCITY	Speed of approach or recession of a body from the point of observation along a line connecting the two. It can be determined by using doppler shift methods.
RADIANT ENERGY	Energy traveling in the form of electromagnetic waves, such as light, infrared, radio, and radar. It is measured in units of energy known as ergs, joules, calories, or kilowatts. The term radiation is generally a synonym, although in nucleonics the term radiation includes energy carried by particles as well as electromagnetic waves.
RADIATION	The emission and propagation of energy or matter. Energy traveling as a wave motion. The energy of electromagnetic waves. Radiant particles such as alpha rays or beta rays. See - electromagnetic radiation gamma radiation high-energy radiation incident radiation nuclear radiation soft radiation solar radiation solar radiation streams ultraviolet radiation visible radiation
RADIATION BELT	A layer of trapped charged particles that surrounds a spatial body.
RADIATION SHIELD	A device used to prevent radiation from biasing the measurement of a quantity and to protect bodies from the harmful effects of nuclear radiation, cosmic radiation, or the like.
RADIO ASTRONOMY	The study of celestial objects through observation of radio waves emitted or reflected by these objects.
RADIO TELESCOPE	A device for receiving, amplifying, and measuring the intensity of radio waves originating outside the Earth's atmosphere.
RADIOMETER	An instrument that detects and measures the intensity of thermal radiation, especially infrared radiation.

RAYS	See - cosmic ray gamma ray
SOLAR ATMOSPHERIC TIDE	Vertical motion of the atmosphere due to thermal or gravitational action of the Sun.
SOLAR CELL	A photovoltaic device that converts sunlight directly into electrical energy.
SOLAR COLLECTOR	A parabolic mirror-type device used to collect and concentrate solar energy.
SOLAR CONCENTRATOR	A device such as a parabolic mirror used to concentrate radiant solar energy to a small area.
SOLAR CORONA	Outer atmospheric shell of the Sun.
SOLAR FLARE	Solar phenomenon which gives rise to intense ultraviolet and corpuscular emission from the associated region of the Sun, affecting the structure of the ionosphere which interferes with communications.
SOLAR MAGNETOGRAM	A recording obtained on Earth that measures the magnetic activity of sunspots.
SOLAR NOISE	Electromagnetic radiation which radiates from the atmosphere of the Sun at radio frequencies.
SOLAR PROTONS	Elementary charged particles and nuclei of hydrogen atoms accelerated by the Sun and ejected into space with energies up to several billion electron volts.
SOLAR RADIATION	The total electromagnetic radiation emitted by the Sun.
SOLAR RADIATION STREAMS	All forms of radiant energy, including visible light, that emanate from the Sun.
SOLAR TIME	Time measured by reference to the apparent motion of the Sun about the Earth.
SOLAR WIND	A stream of protons constantly moving outward from the Sun.
STUDY OF ENHANCED RADIATION BELT - SERB	Program to study the radiation belt created by high altitude nuclear explosion.
SUBATOMIC PARTICLES	A component of an atom such as an electron, proton, meson, etc.

SUDDEN IONOSPHERIC DISTURBANCE	A complex combination of sudden changes in the condition of the ionosphere, and the effects of these changes.
SUNSPOT	A relatively dark area on the surface of the Sun, consisting of a dark central umbra and a surrounding penumbra that is intermediate in brightness between the umbra and the surrounding photosphere.
SUNSPOT CYCLE	A periodic variation in the number and area of sunspots with an average length of 11.1 years but varying between 7 and 17 years.
TROPOPAUSE	The upper limit or limits of the troposphere.
TROPOSPHERE	The lower layer of the Earth's atmosphere, extending to about 60,000 feet at the equator and 30,000 feet at the poles.
ULTRAVIOLET RADIATION	Electromagnetic radiation shorter in wavelength than visible radiation but longer than X-rays. Roughly, radiation in the wavelength interval between 10 and 4000 angstroms.
VAN ALLEN BELTS	Two doughnut-shaped belts of high energy charged particles trapped in the Earth's magnetic field. The minimum altitude of the inner belt ranges from approximately 100 miles near the magnetic poles to more than 1000 miles at the equator. The maximum altitude of the outer belt extends to approximately 40,000 miles at the equator.
WAVELENGTH	Distance measured along a line of propagation between two points which are in phase on adjacent waves.
X-RAY	Electromagnetic radiation of very short wavelength, lying within the wavelength interval of 0.1 to 100 angstroms (between gamma rays and ultraviolet radiation). Also called X-radiation, and roentgen ray.

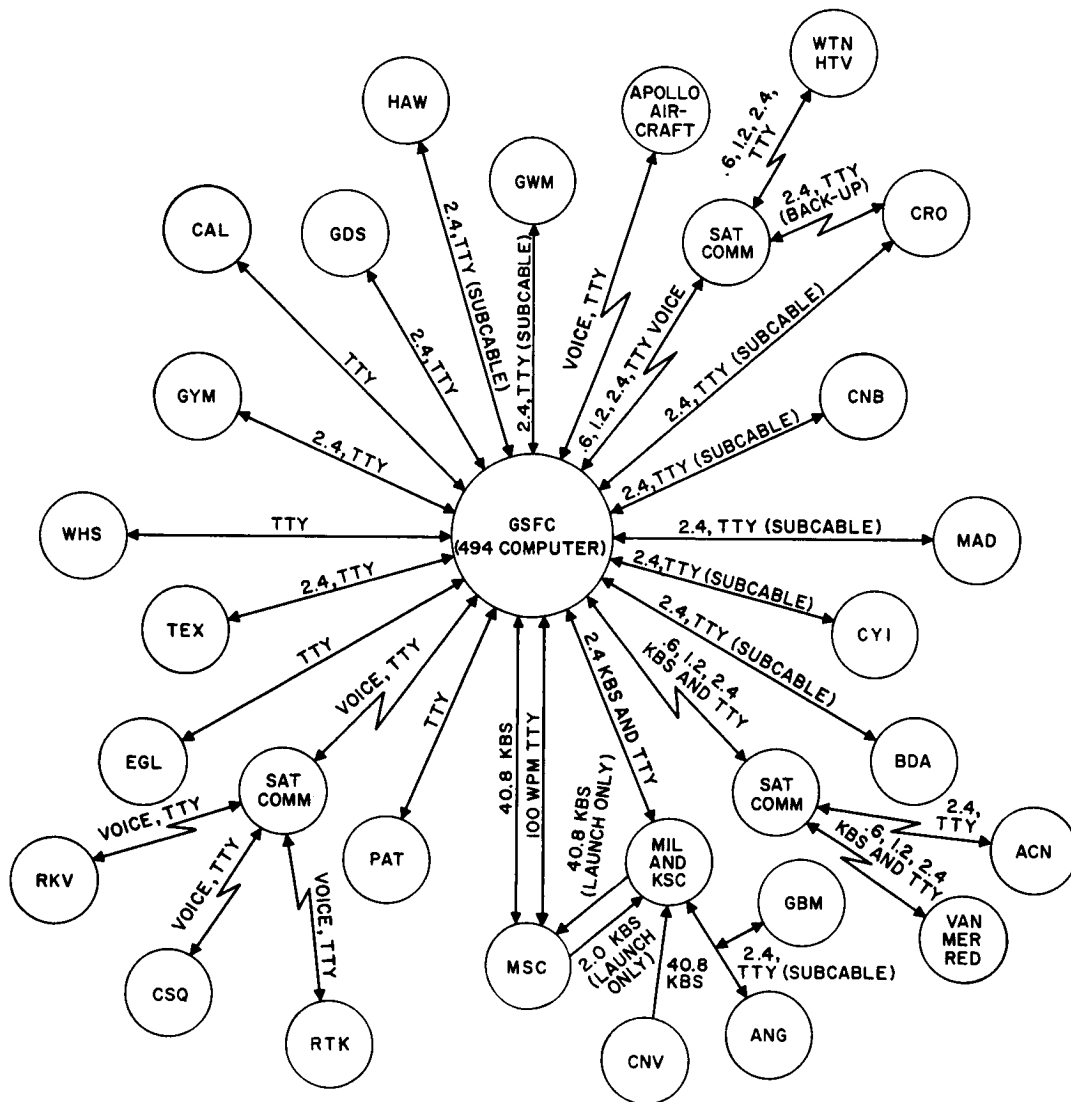

6315011

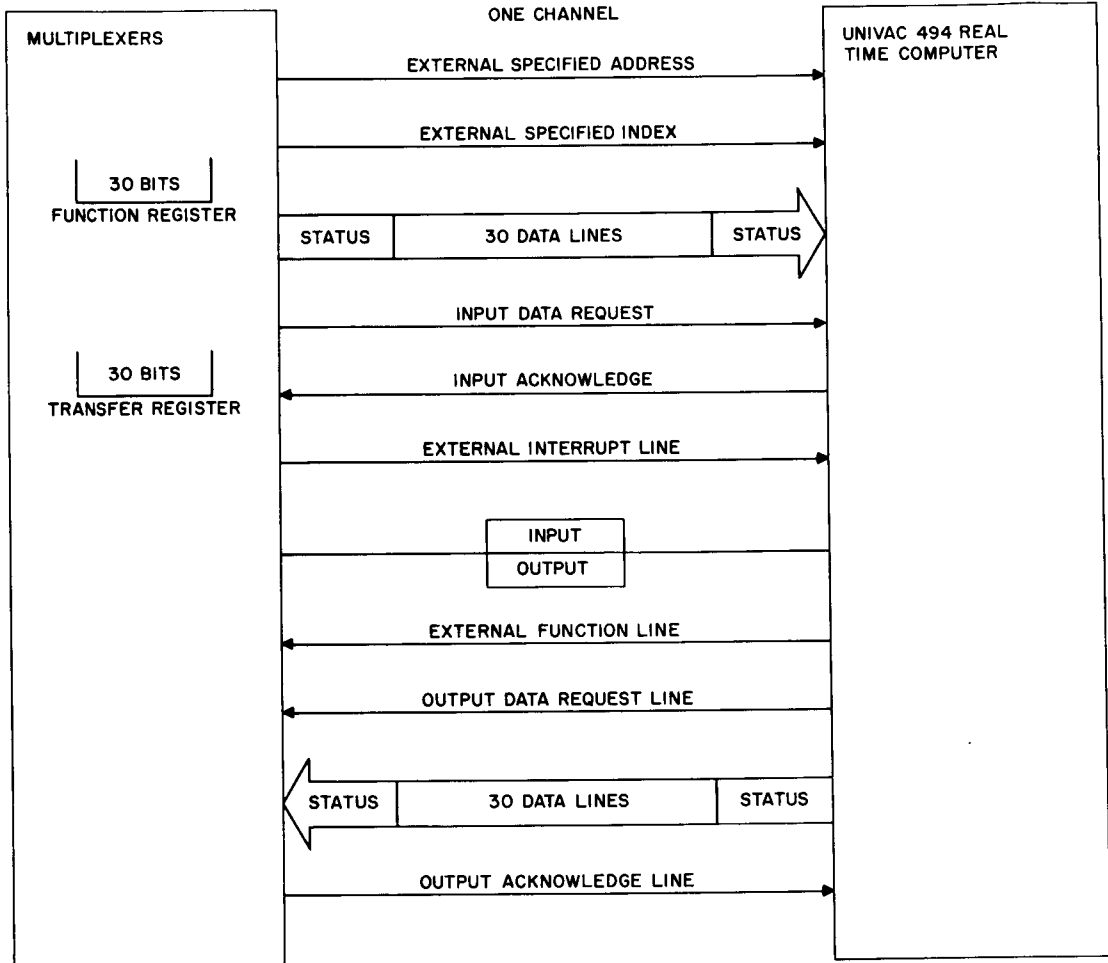

6315010

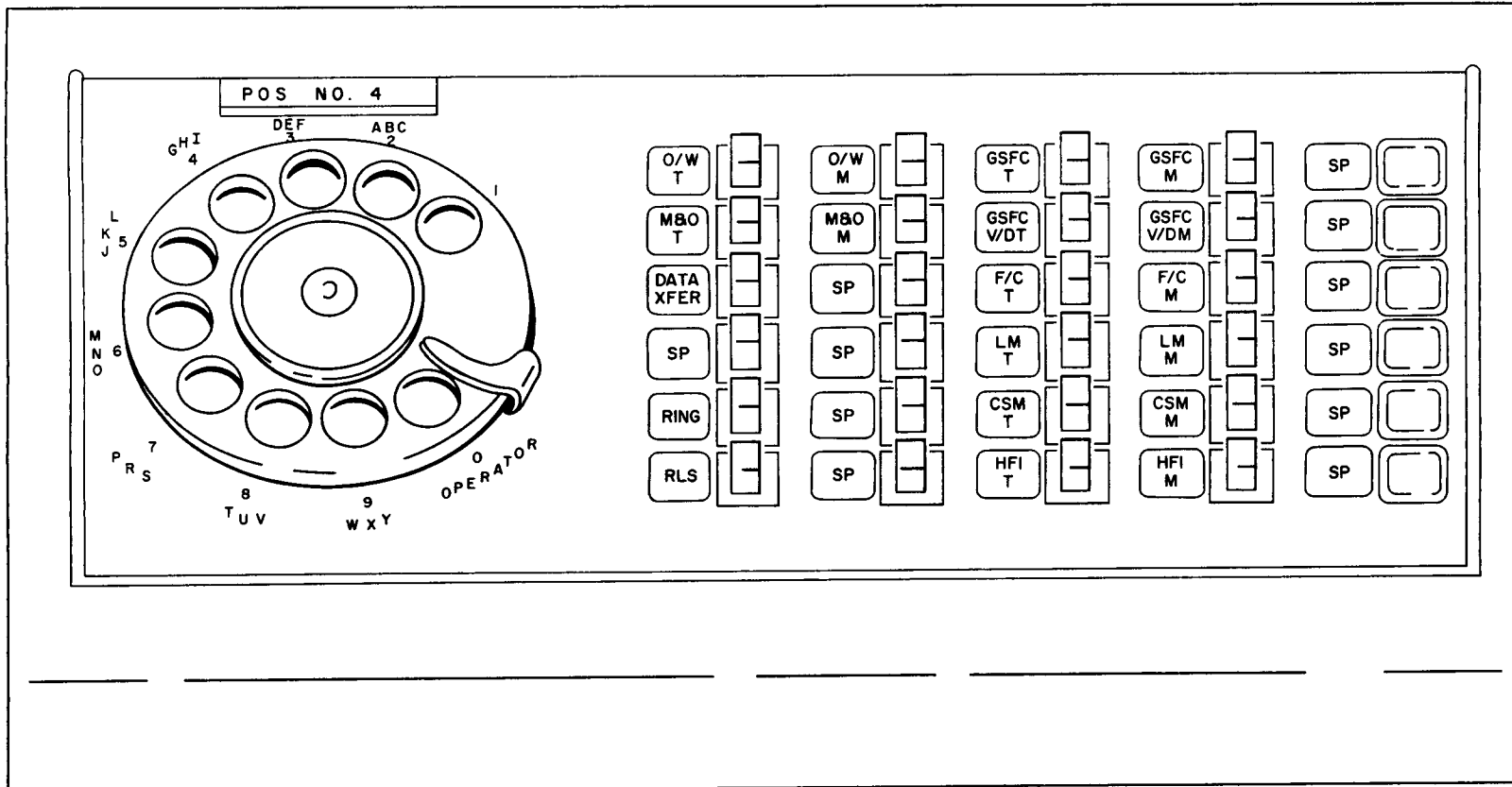

**LEGEND:**

SP- SPARE  
 T- TALK  
 M- MONITOR  
 V/D- VOICE DATA  
 DATA XFER- VOICE DATA TRANSFER  
 O/W- MAINT ORDER WIRE  
 M&O- MAINT AND OPERATIONS

GSFC- GODDARD SPACE FLIGHT CENTER  
 LM- LUNAR MODULE  
 CSM- COMMAND SERVICE MODULE  
 HF- HIGH FREQUENCY  
 FC- FLIGHT CONTROLLER  
 RING- SIGNALING  
 RLS- RELEASE

8315006



13-4

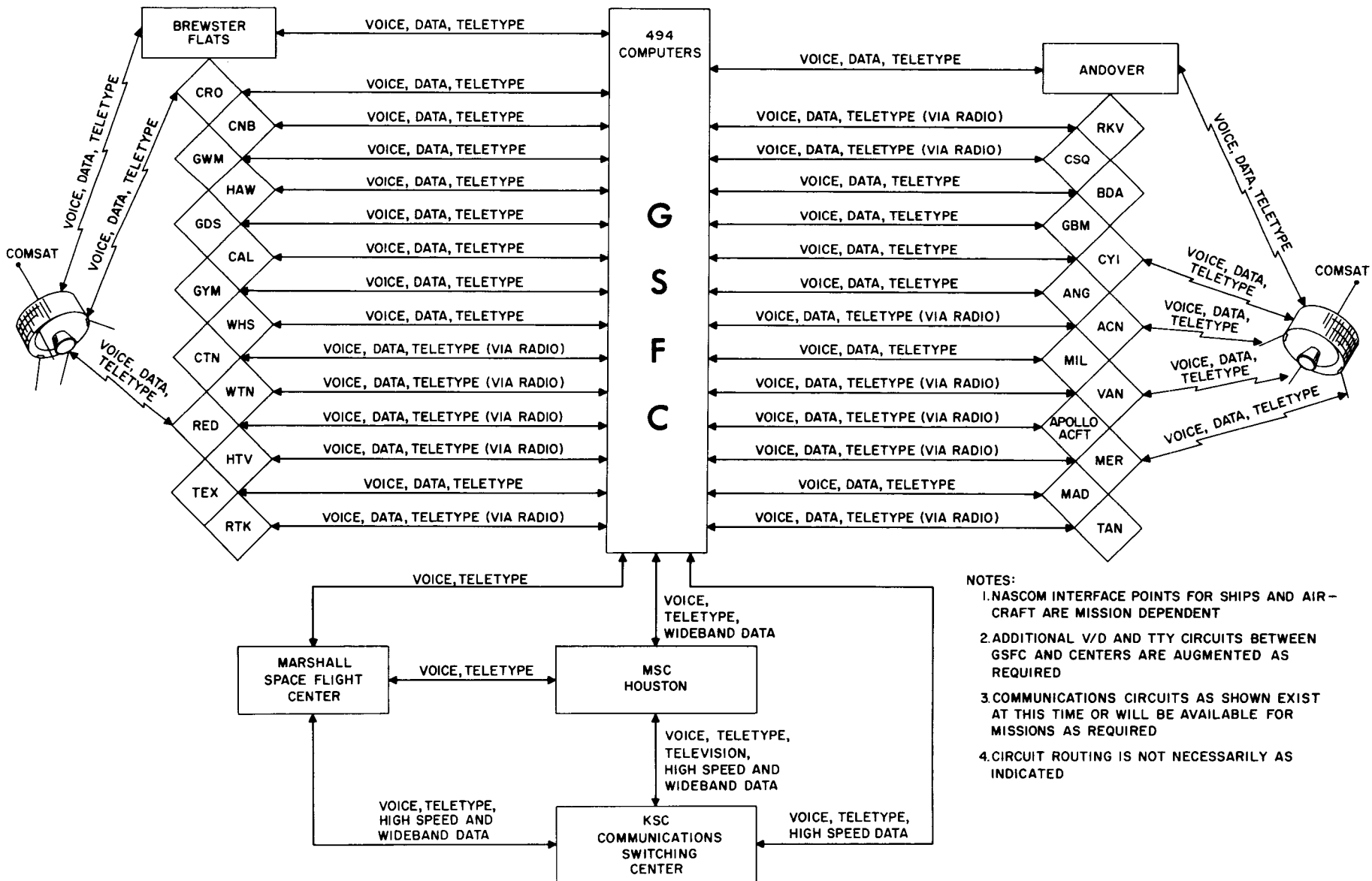

- NOTES:
1. NASCOM INTERFACE POINTS FOR SHIPS AND AIR-CRAFT ARE MISSION DEPENDENT
  2. ADDITIONAL V/D AND TTY CIRCUITS BETWEEN GSFC AND CENTERS ARE AUGMENTED AS REQUIRED
  3. COMMUNICATIONS CIRCUITS AS SHOWN EXIST AT THIS TIME OR WILL BE AVAILABLE FOR MISSIONS AS REQUIRED
  4. CIRCUIT ROUTING IS NOT NECESSARILY AS INDICATED

6315022

## GLOSSARY

### A

A/B	Auto beacon
A/D	Analog-to-digital (data conversion)
AAA	Active acquisition aids
ABORT	Failure of an aerospace vehicle to accomplish its purposes
AC	Alternating current; access control
ACE	Automatic Checkout Equipment
ACK	Acknowledgement
ACQ	Acquisition
ADAP	Adapter
ADE	Adelaide, Australia
ADJ	Adjust
AEM	Aircraft Engineering Modifications
AEROMED	Aeromedical monitor
AFC	Automatic frequency control; Area Frequency Coordinator
AFD	Assistant Flight Director
AFDO	Assistant Flight Dynamics Officer
A/G	Air/Ground (spacecraft voice communications)
AGAVE	Automatic Gimballed-Antenna Vectoring Equipment (AAA)
AGC	Automatic gain control
AM	Amplitude modulation
AMC	Aeromedical console
AMS	Apollo mission simulator
ANLG	Analog
ANO	Alpha-numeric output module
ANT	Antigua, British West Indies (Station 9, AFETR)
AOD	Apollo Operations Director
APO	Apollo Project Office
A/S	Auto-skin track
ASAP	As soon as possible
ASC	Ascension Island (Station 12, AFETR)
ASCO	Automatic sustainer cut off; auxiliary SCO
ASCS	Auto-Stabilization and Control System

ASK	Amplitude shift keying
ASPO	Apollo Spacecraft Program Office
ASR	Automatic send-receive units (TTY modem)
ASTRO	Astronauts
ATT	Attitude
AUTO	Automatic
AUX	Auxiliary
AVC	Automatic volume control
AZ & EL	Azimuth and elevation
AZUSA	Electronic tracking complex and vectoring system (tracking radar at the Cape)

B

BAT	Battery
BCD	Binary code decimal
BCN	Beacon
B/D	Beacon delay
BDA	Bermuda
BECO	Booster Engine Cutoff
BENPAC	Bendix - Pacific
BENRAD	Bendix Radio
BER	Bit error rate
BFEC	Bendix Field Engineering Corp.
BFO	Beat frequency oscillator
BH	Block house
BIN	Binary
BIOMED	Biomedical
B/O	Burn out
BP	Boiler plate
BPF	Bandpass filter
BPS	Bits per second
BST	Brief System Test
BW	Bandwidth

## C

CADFISS	Computer and data flow intergrated subsystems test
CAL	Vandenberg, USAFB, Calif. (NASA)
CAPCOM	Capsule communicator
CB	Circuit breaker
CC	Cubic centimeter
CCC	Command communicator console
C-BAND	Radar frequency range (5200 - 8500 MHz)
CCATS	Command, Computer and Telemetry System
CCIA	Computer console interface adapter
CCW	Counterclockwise
C/D	Countdown
CDP	Central data processor
CET	Capsule elapsed time
C/F	Center frequency
CFE	Contractor-furnished equipment
CLT	Communication line termination or terminal
CM	Command module
CM/SM	Command/Service Modules
CMD	Command
CNV	Cape Kennedy, Florida (Station 1, AFETR)
COMTECH	Communications technician
CONT	Control
C/P	Cartesian-to-polar converter; circular polarization
CP	Communications processor
CPS	Cycles per second
CRF	Capsule radiation measurements
CRO	Carnarvon, Australia
CRR	Change Recommendation Report
CRT	Cathode-ray tube
CSM	Command service module
CSQ	Coastal Sentry Quebec (ship)

CT	Command transmitter
CTC	Capsule test conductor
CTE	Central timing equipment
CTN	Canton Island
CW	Continuous wave; clockwise
CYI	Grand Canary Island

D

D/A	Digital-to-analog
D/R	Data receiver
DBM	Decibel referred to 1 milliwatt
DBV	Decibel referred to 1 volt
DC	Direct current; differential correction
DCR	Digital clock receiver
DCS	Digital command system
DCT	Digital clock transmitter
DCU	Data control unit; digital control unit
DECOM	Decommutation
DEMOD	Demodulate
DF	Direction finder
DIRAM	Digital ranging machine
DIS	Data input subsystem
DISCH	Discharge
DISTRAM	Digital space trajectory measurement system
DOB	Data Operations Branch (MFOD)
DOD	Department of Defense
DOS	Department of Supply (Australia)
DOVAP	Doppler, velocity, and position tracking system
DRUL	Down-range uplink
DSE	Data storage equipment
DSDU	Decommutation system distribution unit
DSIF	Deep Space Instrumentation Facility
DST	Detailed System Test
D/TTY	Digital-to-teletype converter

## E

ECA	Electronic control assembly
ECS	Environmental control system
ECU	Environmental control unit
EGL	Eglin USAFB, Florida
EI	Engineering Instruction
EKG	Electrocardiogram
EL	Elevation
ELS	Earth landing system
EM	Engineering Memorandum
EMERG	Emergency
ENG	Engine
ENVIR	Environmental
EPS	Electrical power system
ESS	Essential
ETR	Eastern test range
EVA	Extra-vehicular astronaut
EVAP	Evaporator
EXH	Exhaust

## F

F	Fuel
FAR	Failure analysis report
FAX	Facsimile
F/C	Fuel cell
FCSD	Flight crew support division (MSC)
F-1	Firing day minus one
FD	Flight Director
FIDO	Flight Dynamics Officer
FM	Frequency modulation
FM/FM	Frequency division multiplexing
FPQ	Fixed, ground, special purpose radar
FPS	Fixed position tracking radar; frames per second
FSECO	First-stage engine cutoff

FSK                    Frequency shift keying  
FWD                    Forward

G

GBI                    Grand Bahama Island (Station 3, AFETR)  
GCC                    Ground communications coordinator  
GET                    Ground elapsed time  
GFE                    Government-furnished equipment  
GFP                    Government-furnished parts  
GLOTRAC              Global tracking (presently the AFETR)  
GMT                    Greenwich mean time  
GMTEL                Earth landing  
GMTLA                Initiate abort  
GMTLR                Lunar rendezvous  
GMTMB                "Moon blackout"  
GMTMC                Midcourse correction  
GMTOI                Orbital insertion  
GMTRE                Reentry  
GMTTE                Transearth injection  
GMTTL                Translunar injection  
GMTVA                Vehicle acquisition  
G&N                    Guidance and Navigation  
GOSS                   Ground Operation Support System  
GRD                    Ground (formerly GND)  
GSE                    Ground support equipment  
GSFC                   Goddard Space Flight Center  
GTK                    Grand Turk Island  
GYM                    Guaymas, Mexico

H

HAW                    Kauai, Hawaii  
HF                    High frequency (3-30 MHz)  
HON                    Honolulu, Hawaii  
HS                    High speed  
HSD                    High speed data

## I

I/A	Inactive
I & C	Installation and checkout
IBM	International Business Machines
ID	Identification
IF	Intermediate frequency
IFA	In-flight analysis
IGS	Inertial guidance system
IMU	Inertial measurement unit
INJ	Injection
INS	Inertial navigation system; insertion
I/O	Input/output
I/P	Impact predictor; impact point
IPS	Inch-per-second; instrument power system
IR	Infrared system
IRACQ	Instrumented radar acquisition
ISI	Instrumentation/support instructions
ISO	Isolation
ITT	International Telephone and Telegraph
IU	Instrument unit (a portion of the Saturn V)

## J

JETT	Jettison
JON	Johannesburg, South Africa
JPL	Jet Propulsion Laboratories

## K

Ka-band	17.25 - 36.00 KMHz (GHz)
KB	Kilobits
KBPS	Kilobits per second
KC	Kilocycles per second
KMC	Kilomegacycles
KSR	Keyboard send/receive unit
Ku-band	10.90 - 17.25 KHz
KW	Kilowatt



L

LASER	Light amplification by stimulated emission of radiation
L-band	390-1550 MHz
LCC	Launch Control Center
LCS	Launch Control System
LDN	London Communications Center, England
LEB	Lower equipment bay
LEPS	Lunar Excursion Propulsion System
LES	Launch Escape Subsystem
LF	Low frequency (30 to 300 KHz)
LH	Left-hand circular polarization
LIQ	Liquid
LM	Lunar Module
L/O	Liftoff
LO	Low
LOR	Lunar orbit rendezvous
LOS	Loss of signal
LR	Lunar rendezvous
LSB	Least significant bit; lower sideband
LSD	Low-speed data
LSS	Life Support System
LV	Launch vehicle
LW	Launch window

M

M&O	Mission and operations; maintenance and operations
MA	Milliampere
MAN	Manual
MASER	Microwave amplification by stimulated emission of radiation
MAX	Maximum
MC	Megacycle ( $10^6$ cycles/sec); midcourse correction
MCC	Mission Control Center

nm	Nautical miles
NOD	Network Operations Director (NASA)
NORAD	North American Air Defense Command
NRZ	Non-return to zero
NRZC	Non-return to zero (change)
NRZM	Non-return to zero (mark)
NRZS	Non-return to zero (space)
NSG	Network Support Group (Contractor personnel working at GSFC and Cape Kennedy)
NSM	Network Status Monitor
NST	Network Support Team

O

OMSF	Office of Manned Space Flight
OPS	Operations
OPS DIR	Operations Director
OR	Operations Requirement

P

PA	Power amplifier
PAFB	Patrick Air Force Base (adjacent to Cape Kennedy) Station O, ETR
PAM	Pulse-amplitude modulation
PAO	Public Affairs Office (MSC)
P/B	Plotboard
P-band	225-390 MHz
PBX	Private branch plugboard exchange (telephone)
PCM	Pulse code modulation
PDM	Pulse-duration modulation
PIO	Public Information Office
PIRD	Program Instrumentation Requirements Document
PL	Post landing
PLIM	Post launch and instrumentation message
PLSS	Portable Life Support System
PM	Pulse modulation; phase modulation; Post Meridian

PMP	Premodulation processor; Program Management Plan
P/P	Point-to-point (radio)
PPS	Pulse per second
PR	Pulse rate
PRE	Pretoria, South Africa (Station 13, ETR)
PRESS	Pressure
PRF	Pulse repetition frequency
PRI	Primary
PROG	Program
PROP	Propellant
P/S	Parallel-to-serial
psia	Pounds per square inch absolute
psig	Pounds per square inch gauge
PSK	Phase shift keying
PSRD	Program Support Requirements Document
Ptt	Push to talk
PWR	Power
PYRO	Pyrotechnics
Q	
Q-band	36.00 - 46.00 KMHz (GHz)
QTY	Quantity
R	
RCAC	Radio Corp. of America Communications
RCC	Recovery Control Center
RCS	Reaction Control System; Reentry Control System
RCVR	Receiver
RDR CON	Radar Controller
REC	Receiver
REG	Regulator
REV	Reverse
RF	Radio frequency; recovery forces
RH	Right-hand circular polarization
RKV	Rose Knot Victor (ship)

MCS	Megacycles per second
MCT	Memory cycle-time
MED	Medium
MET	Mission elapsed time
MF	Medium frequency (300 to 3000 kc)
MFD	Mission Flight Director
MFEB	Manned Flight Engineering Branch
MFOB	Manned Flight Operations Branch
MFOD	Manned Flight Operations Division (GSFC)
MILA	Merritt Island Launch Area
MILS	Missile Impact Location System
MIN	Minimum
MINITRACK	Orbit-Monitoring and Data-Collection System
MISTRAM	Missile Trajectory Measurement System
MODEM	Modulator/demodulator
MOSS	Manned Orbital Space System
MSB	Most significant bit
MSC	Manned Spacecraft Center
MSFC	Marshall Space Flight Center
MSFN	Manned Space Flight Network
MTU	Magnetic Tape Unit
MUX	Frequency Multiplex Equipment

N

N/A	Not applicable
NASA	National Aeronautics and Space Administration
NASCOM	NASA Worldwide Communications Network
NASCOP	NASA Communications Operating Procedure
NCG	Network Control Group (A scheduling group, located at GSC, with representatives from MFOD, MSC, and DOD)
NCR	Network Change Request
NDR	Network data reduction
N&G	Navigation and Guidance System

RLSE	Release
RM	Rendezvous maneuver
RO	Page receive only machine; recovery operations
ROTR	Receive only typing reperforator
RR	Range and range rate
RSDP	Remote Site Data Processor
RSO	Range Safety Officer
RTCC	Real time computer complex
RTK	USNS Range Tracker (ship)
RUPT	Interrupt
RZ	Return to zero
S	
S-	Saturn stage (prefix)
S-band	1550 - 5200 MHz
S/C	Spacecraft
S/N	Signal-to-noise
SAR	Search and rescue
SC	Spacecraft
SCAMA	Switching conferencing and monitoring arrangement
SCATS	Simulation Checkout and Training System
SCE	Signal Conditioner Equipment
SCR	Strip Chart Recorder
SCS	Stabilization and Control System
SD	Send data
SEC	Secondary
SECO	Sustainer engine cutoff
SEP	Separation
SEQ	Sequencer
SHF	Super high frequency (3000 to 30,000 MHz)
SIG	Signal
SIM	Simulation
SM	Service Module
SOFAR	Sonar sound fixing and ranging

SOM	Start of message
SOP	Standard Operating Procedures
SOW	Start of word
S/P	Serial to parallel
SPADATS	Space Detection and Tracking System
SPANDAR	Space Range Radar (Raytheon)
SPE	Special message
SPS	Service Propulsion System; samples per second
SSB	Single sideband
S/S	Subsystem; signal strength
STA	Station
STADIR	Station Director
STAT	Status
SUM	Summary
SVC	Service message
SYS	System

T

T/C	Telecommunications
T/E	Telemetry event
T/M	Telemetry
T/R	Transmit/receive
TC	Test conductor; time to computer (IBM)
TDD	Timing data distribution
TEC	Transearch coast
TEMP	Temperature
TEX	Corpus Christi, Texas
TLC	Translunar coast
TLM	Telemetry
TM	Telemetry (data)
TP	Test procedure
T-Time	Time in minutes or seconds from lift-off
TTE	Time-to-event
TTY	Teletype

TTY-FD	Full duplex teletype
TV	Television; television systems monitor
TWX	Teletypewriter exchange or communication

U

UHF	Ultra-high frequency (300-3000 mc)
USB	Upper sideband (Unified S-Band)
USBE	Unified S-Band equipment
USWB	United States Weather Bureau

V

V	Velocity voice
VAB	Vehicle Assembly Building
VAC	Volts AC
V-band	46.00 - 56.00 KMHz (GHz)
VC	Voice frequency channel
VCO	Voltage controlled oscillator
VDC	Volts DC
VEH	Vehicle
VERLORT	Very Long Range Tracking Radar
VFO	Variable frequency oscillator
VHF	Very high frequency (30-300 mc)
VLF	Very low frequency (3 to 30 kc)

W

W/B	Wideband
WECO	Western Electric Company
WHS	White Sands, New Mexico, missile range
WMS	Waste Management System
WOM	Woomera, S. Australia
WPM	Words-per-minute
WPS	Words-per-second
WLPS	Wallops Island station
WTR	Western Test Range
WWVB	NBS radio station, Boulder, Colorado

WWVH NBS radio station, Maui, Hawaii  
WWVL NBS radio station, Boulder, Colorado

X

X-band 8500 - 10900 MHz  
XCVR Transceiver (combined data xmtr and rcvr)  
XDUCER Transducer  
XMT Transmit  
XMTR Transmitter

MSFN MANUAL DESIGNATION SYSTEM

MC	Computer
ME	Equipment
ME-900	IBM
MG	General
MH	Subsystem
MO	Operations & CADFISS
MP	Property
MS-100	System (Mercury)
MS-200	System (Gemini)
MS-400	System (Apollo)
MT	Training