

NASA/TM—2019-220052



# Magnetic Levitation for Long-Life Space Mechanisms: Technology Assessment and Remaining Challenges

*Samuel A. Howard and Christopher DellaCorte*  
*Glenn Research Center, Cleveland, Ohio*

*Michael J. Dube*  
*Langley Research Center, Hampton, Virginia*

## NASA STI Program . . . in Profile

Since its founding, NASA has been dedicated to the advancement of aeronautics and space science. The NASA Scientific and Technical Information (STI) Program plays a key part in helping NASA maintain this important role.

The NASA STI Program operates under the auspices of the Agency Chief Information Officer. It collects, organizes, provides for archiving, and disseminates NASA's STI. The NASA STI Program provides access to the NASA Technical Report Server—Registered (NTRS Reg) and NASA Technical Report Server—Public (NTRS) thus providing one of the largest collections of aeronautical and space science STI in the world. Results are published in both non-NASA channels and by NASA in the NASA STI Report Series, which includes the following report types:

- TECHNICAL PUBLICATION. Reports of completed research or a major significant phase of research that present the results of NASA programs and include extensive data or theoretical analysis. Includes compilations of significant scientific and technical data and information deemed to be of continuing reference value. NASA counter-part of peer-reviewed formal professional papers, but has less stringent limitations on manuscript length and extent of graphic presentations.
- TECHNICAL MEMORANDUM. Scientific and technical findings that are preliminary or of specialized interest, e.g., “quick-release” reports, working papers, and bibliographies that contain minimal annotation. Does not contain extensive analysis.
- CONTRACTOR REPORT. Scientific and technical findings by NASA-sponsored contractors and grantees.
- CONFERENCE PUBLICATION. Collected papers from scientific and technical conferences, symposia, seminars, or other meetings sponsored or co-sponsored by NASA.
- SPECIAL PUBLICATION. Scientific, technical, or historical information from NASA programs, projects, and missions, often concerned with subjects having substantial public interest.
- TECHNICAL TRANSLATION. English-language translations of foreign scientific and technical material pertinent to NASA's mission.

For more information about the NASA STI program, see the following:

- Access the NASA STI program home page at <http://www.sti.nasa.gov>
- E-mail your question to [help@sti.nasa.gov](mailto:help@sti.nasa.gov)
- Fax your question to the NASA STI Information Desk at 757-864-6500
- Telephone the NASA STI Information Desk at 757-864-9658
- Write to:  
NASA STI Program  
Mail Stop 148  
NASA Langley Research Center  
Hampton, VA 23681-2199



# Magnetic Levitation for Long-Life Space Mechanisms: Technology Assessment and Remaining Challenges

*Samuel A. Howard and Christopher DellaCorte  
Glenn Research Center, Cleveland, Ohio*

*Michael J. Dube  
Langley Research Center, Hampton, Virginia*

National Aeronautics and  
Space Administration

Glenn Research Center  
Cleveland, Ohio 44135

## Acknowledgments

The authors would like to acknowledge the support of the NASA Engineering and Safety Center (NESC) Mechanical Systems Technical Discipline Team for continued support, without which this work would not have been possible.

This report contains preliminary findings,  
subject to revision as analysis proceeds.

*Level of Review:* This material has been technically reviewed by technical management.

Available from

NASA STI Program  
Mail Stop 148  
NASA Langley Research Center  
Hampton, VA 23681-2199

National Technical Information Service  
5285 Port Royal Road  
Springfield, VA 22161  
703-605-6000

This report is available in electronic form at <http://www.sti.nasa.gov/> and <http://ntrs.nasa.gov/>

# **Magnetic Levitation for Long-Life Space Mechanisms: Technology Assessment and Remaining Challenges**

Samuel A. Howard and Christopher DellaCorte  
National Aeronautics and Space Administration  
Glenn Research Center  
Cleveland, Ohio 44135

Michael J. Dube  
National Aeronautics and Space Administration  
Langley Research Center  
Hampton, Virginia 23666

## **Summary**

Spacecraft mechanisms and mechanical systems must operate reliably and without failure to enable successful, long-term space missions. Such requirements place demands upon the tribological elements, especially bearings, that are frequently difficult or impossible to satisfy. Several recent high-profile bearing failures in coolant fluid pumps and attitude control system momentum wheels provided the impetus to assess the state-of-the-art noncontacting magnetic levitation-based rotor support technologies. Magnetic levitation technology continues to gain acceptance for terrestrial applications and has been demonstrated for spaceflight in mechanical systems such as reaction wheels, but it is not in widespread use. The specific reasons inhibiting this new technology are not readily clear but include cost, weight, performance, and perceived risk. These reasons arise from a variety of real and perceived technical limitations in areas like materials, controls, sensors, thermal management, and others. This white paper seeks to determine, define, and quantify the technical hurdles and gaps that must be overcome to enable the broad adoption of noncontacting bearings for long-life space mechanisms. It is anticipated that a better understanding of this complex topic may guide resource investments and clear the path to improved performance mechanical systems for spacecraft.

## **Introduction**

“Bearing” is the generic term used to describe a mechanical component that constrains a rotating structure (rotor) with respect to a nonrotating structure (stator), while significantly reducing friction and wear between the mating surfaces. There are two primary types of bearings used in rotating mechanical systems: rolling element bearings and journal (sleeve) bearings. For each of these, there are several subcategories, but all rotating machines have bearings of one type or another. Rolling element bearings, typical examples of which are shown in Figure 1, are the most common type of bearing, consisting of an inner ring and an outer ring separated by an array of rolling elements (commonly either balls or rollers). The basic operating principle relies on the rolling contact between the races and the rolling elements to reduce friction and wear while supporting a force normal to the two contacts. The rolling contact is usually lubricated with solid lubricants, oil, or grease, to reduce friction, prevent metal-to-metal contact, and extend the life of the bearing and machine (Ref. 1).

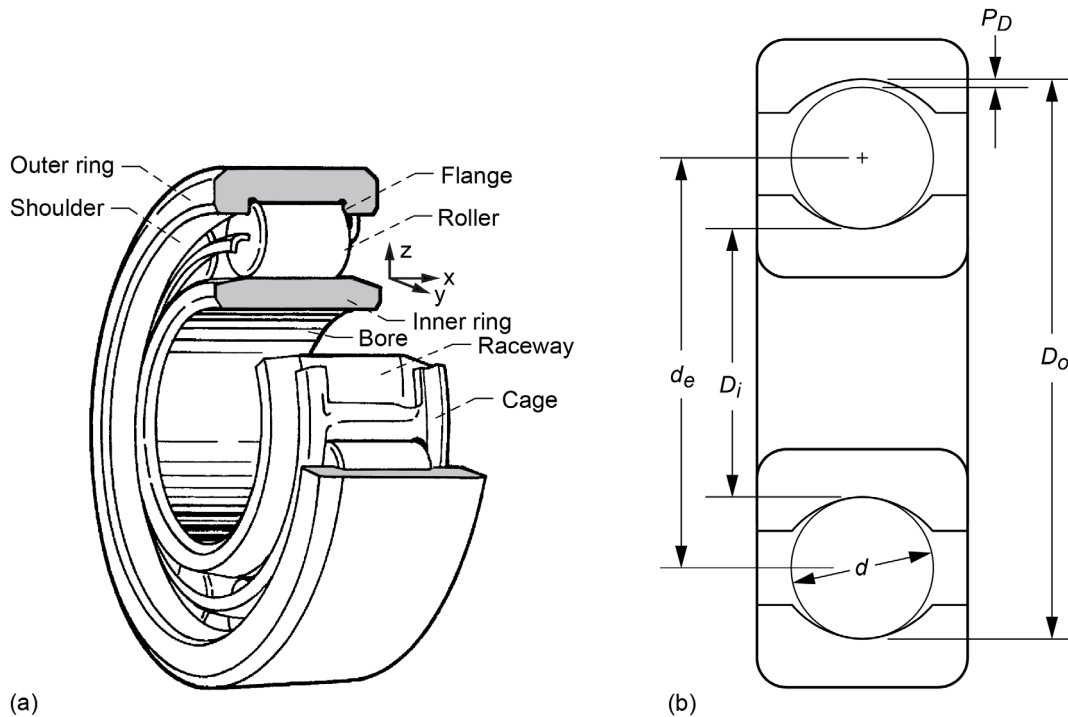

Figure 1.—Typical rolling element bearing designs. (a) Angular contact ball bearing. (b) Cylindrical roller bearing.

The second most common bearing type, journal or sleeve bearings, operate on an entirely different principle. In journal bearings the surfaces are separated by a fluid, which can be a liquid or gas. In dry running journal bearings, solid lubricants are used to reduce friction and wear, and these bearings are often referred to as “bushings.” Figure 2 shows a common fluid film bearing with an inner sleeve and an outer sleeve. There is a small gap between the sleeves filled with the fluid (lubricant). As the two sleeves rotate with respect to one another, fluid viscosity causes the pressure to build and provides a normal force to separate the surfaces and reduce friction and wear (Ref. 2).

Magnetic bearings are a specialized bearing type that do not fit into the previous categories. Magnetic bearings (Figure 3) are less common, but are beginning to see terrestrial application in areas such as industrial pumps, blowers, power generation, and other similar machines. A magnetic bearing utilizes either permanent magnets or electromagnets to apply forces (attractive or repulsive)—without contact—to suspend the rotating component in a piece of machinery. Passive permanent magnet bearings (including recently emerging Halbach arrays) require no power to generate forces, and therefore could prove to be a very low-power consumption option. However, they are inherently unstable unless they include at least one actively controlled degree of freedom, or in the case of Halbach arrays, operate above a minimum threshold speed. Thus, passive systems may pose some challenges for system stability. In contrast to passive magnetic bearings, active electromagnetic bearings require power to generate forces, but can generally provide larger forces and can be made conditionally stable for a wide range of operating conditions. The obvious benefits include no frictional loss in the bearings (in vacuum), no wear while levitated, and the elimination of lubricants. Additional secondary benefits include the potential for active vibration control and embedded health monitoring, smooth operation, reduction of susceptibility to contaminants, and more. However, there are drawbacks, including possible higher cost, more weight, additional electronics, power requirements, necessity for backup bearings, and so forth. Furthermore, magnetic bearings require a control system made of many different parts, and thus the overall reliability is a concern.

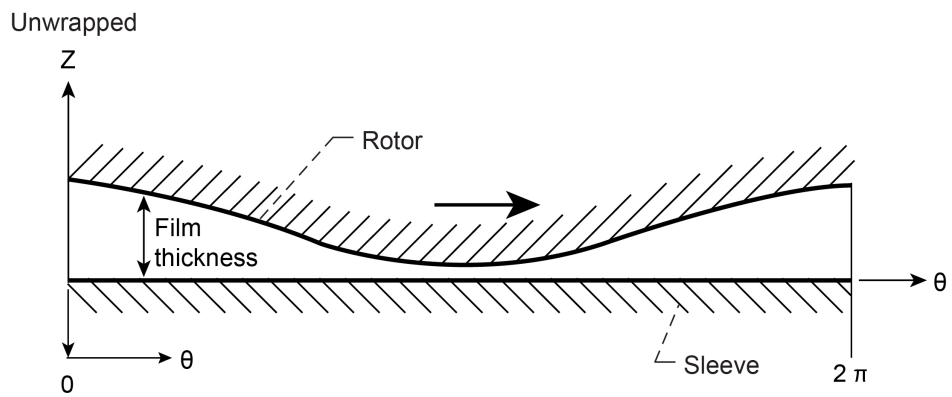
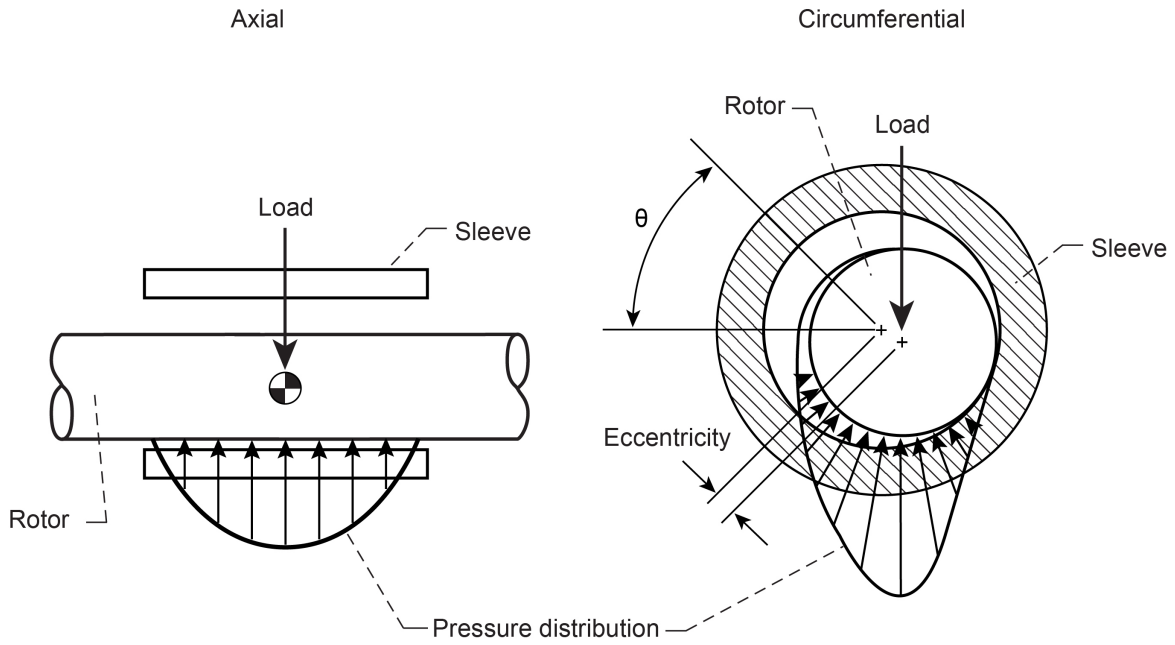

Figure 2.—Typical plain journal bearing. (a) Axial. (b) Circumferential. (c) Unwrapped.

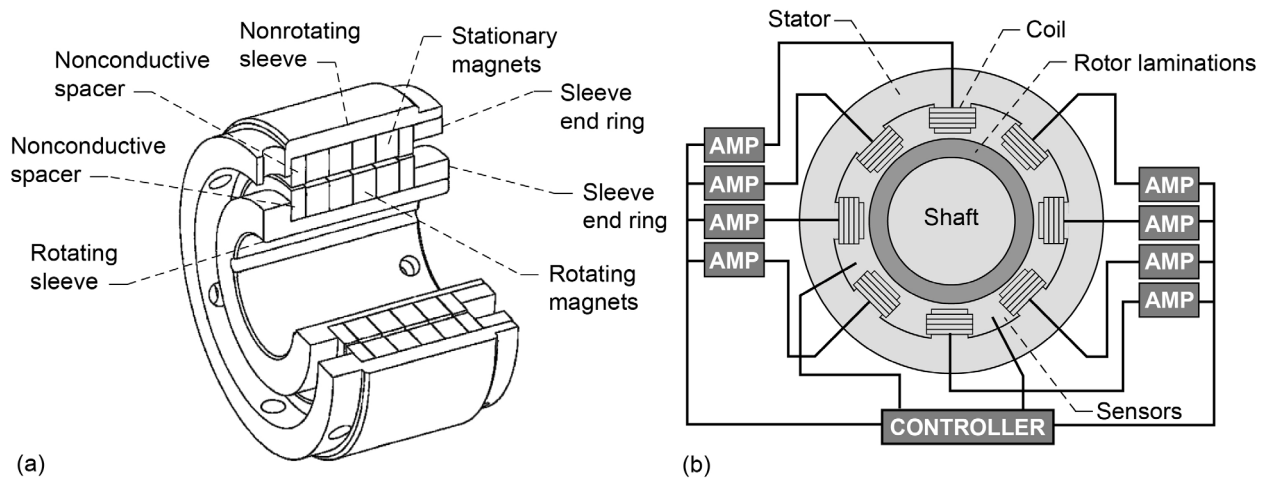

Figure 3.—Magnetic bearings. (a) Homopolar permanent magnet bearing (from Ref. 3). (b) Heteropolar active magnetic bearing (derived from Ref. 4).

All magnetic bearing systems consist of several subsystems that each add complexity and have their own technical challenges. For example, the stators of a magnetic bearing usually have electromagnetic coils made up of wound conductor wire. These wires have electrical resistances that can lead to thermal management challenges, and the wire insulation has limited temperature capabilities. The magnetic flux strength is also limited, and thus magnetic bearings generally have lower load capability than conventional bearings. The active control systems used in magnetic bearings to maintain the rotor position include sensors, amplifiers, and circuitry that require power and have their own possible failure modes. The last primary subsystem is the rotor itself, and it is often made from laminated plates. This design approach improves performance, but again adds complexity and failure pathways. In general, an active magnetic levitation system is more complex than a passive mechanical bearing system, and complexity tends to add cost and hinder reliability. However, technological advances can outweigh such drawbacks and enable higher performance and new capabilities, which make magnetic bearings attractive despite increased complexity. For some missions, magnetic bearing technology may not only be attractive, it may be necessary to meet the needs of the mission. For these reasons, magnetically levitated machines have potential to see more widespread use in space.

Magnetic bearings have limited but well-documented heritage in space applications. For example, the French Satellite Pour l’Observation de la Terre (SPOT) series of satellites, and the European Space Agency’s (ESA’s) European Remote Sensing (ERS) satellites, utilize magnetic-bearing-supported reaction wheels (RWs) for attitude control (Ref. 5).

Magnetic bearing history in space RWs began in France in 1986 with the launch of the SPOT 1 satellite, which had three 15-Nms RWs. That design was used successfully in four other applications: SPOT 2 and SPOT 3 launched in 1990 and 1993, respectively, and ERS 1 and ERS 2, in 1991 and 1995. A larger, 40-Nms version of the same design was utilized in the European Helios series of satellites starting in 1995. As of 1996, all of these applications combined had accumulated over 88 years of incident-free, on-orbit flight hours, demonstrating that magnetic bearing technology can be successfully applied to space applications (Ref. 5).

The history discussed above suggests that the potential reliability of such systems can be adequate, but it does not elucidate other tradeoffs and challenges when compared to using conventional bearing technology. To better grasp the challenges facing magnetic levitation, it is helpful to first review the requirements typically considered when designing conventional bearings for space applications.

A primary design consideration when selecting a bearing type is the bearing load. The two different conventional bearing types (rolling element and fluid film), each have advantages and disadvantages for a given application. Magnetic bearings have an altogether different load profile. For example, Figure 4 shows qualitative load capability for fluid film bearing, rolling element bearing, and magnetic bearing

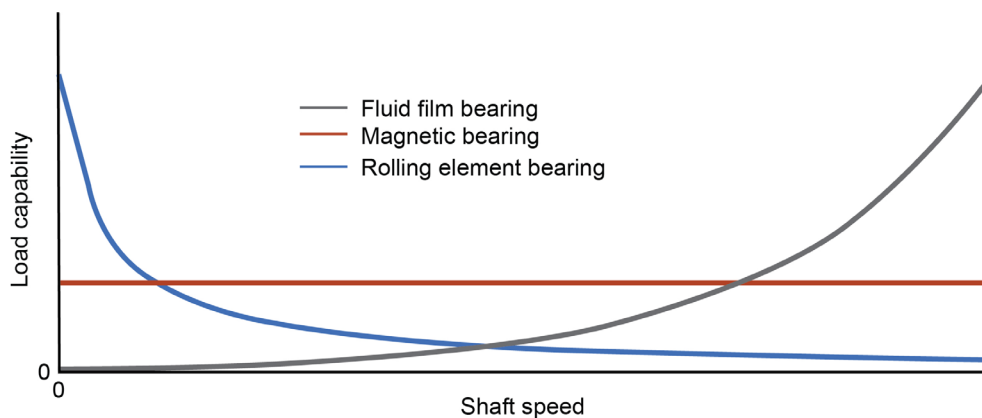

Figure 4.—Comparison of bearing technology load capability versus rotational speed.



types as a function of speed. For journal bearings, load capability is zero at zero speed, but increases to relatively high loads at high speeds. Rolling element bearings have maximum load capability at low speeds, with a dropoff at higher speeds. Magnetic bearings have nearly constant load capability regardless of speed. Load-carrying characteristics are only one property of bearings that must be considered during the design phase of hardware, and Figure 4 illustrates how differently various bearing types can behave. Designers must weigh all of the tradeoffs of each type of bearing to select a bearing for a particular application. In addition to load capacity, the various bearings also have very different dynamic force behavior as well, which must be considered in the design phase.

Space mechanisms are dominated by the use of rolling element bearings lubricated by a fixed amount of vacuum-compatible oil or grease. Regardless of the type of bearing used, lubrication in space mechanisms is a challenging tribology problem that has been studied in significant detail for several decades (Ref. 6). Current space lubricants have come a long way toward extending the limits of what can be done in terms of long life, low volatility, and low friction and wear. However, the fundamental challenges remain: over time lubricants are consumed, evaporate, or creep out of the tribology contact, and the bearings will eventually fail. Lubricant replenishment techniques and alternate bearing technologies are still not widely prevalent. Thus, at least for high-speed mechanical space mechanisms, the life-limiting factor will likely continue to be the lubricant (Ref. 7).

When considering the risks and rewards associated with any new application of a technology compared to a technology with flight history, it is useful to consider examples in which the existing technology is challenged. Such example space mechanisms include attitude control systems, high-speed vacuum pumps, fluid pumps, cryogenic turbopumps, and high-speed motors. These machine classes are demanding of their bearings because of one or more of the typical requirements of high speed, long life, lubricant limitations, vibration, unknown or uncharacterized loads, and so forth.

It should come as no surprise that examples exist of these applications wherein the bearings have exhibited a range of problems from slight disturbances to complete failure during their intended missions. The mission repercussions of bearing issues vary in severity as well, based on how serious the issues are and when in the life cycle they occur. Illustrative failures of machines supported by both rolling element and fluid film bearings are examined and discussed further in the following paragraphs.

Recently, two high-profile on-orbit attitude control system (ACS) failures have drawn attention to the bearing systems of space mechanisms. A brief discussion of these failures illustrates the potential benefits of developing an alternative bearing technology for rotating space mechanisms. In June 2002, one of four control moment gyroscopes (CMGs) in the International Space Station (ISS) ACS began to show signs of distress with increasing spin motor command current (SMCC). The increasing SMCC required from the drive motor was an indication that drag torque in one or more of the bearings was increasing. It was later determined that, in fact, the bearing on the hall sensor side of the CMG had failed from insufficient preload. During September to October 2006, a second CMG from the ISS array experienced high vibration sufficient to eventually shut it down and remove it from operation. The failure investigation team later determined the likely cause of high vibration was again loss of preload. In both of these failures, the preload was affected by fretting wear between the bearing outer race and the support structure, contributing to compromised preload and ball skidding (Ref. 8). The significance of the CMG failure aboard the ISS was quite high: the failed units were swapped for on-orbit spares and returned to Earth for refurbishing, all at great expense. Additionally, there is more uncertainty about the expected life of the units in operation now, the remaining spares, and how that affects the life cycle of the ISS itself.

Bearing issues have also been responsible for problems prior to launch. A small, high-speed molecular turbopump on the Mars Science Laboratory rover Curiosity experienced development setbacks related to bearing problems. During life testing, the bearing cages were failing, which threatened to delay the mission

that eventually launched in November of 2011, after several other delays had already occurred. The cage failures were indirectly related to the lubrication challenges. When a porous cage material was used for lubrication retention, and therefore longer life, the material was weak and brittle and surviving the assembly and life testing was difficult. However, nonporous materials that were stronger could not store extra lubricant, so the lubricant life requirements were difficult to meet. Ultimately, the porous material was chosen with a post-assembly inspection to make sure the cages did not fail during the assembly phase. Also on the Curiosity rover, some of the gearboxes used in various drive systems and actuators experienced development delays related to lubrication in the gearbox bearings.

In July 2012, one of four RWs in the Kepler Space Telescope ACS failed because of erratic and high friction. Shortly after that, in May 2013, a second RW failed similarly. Unlike the hardware in the ISS ACS, the Kepler hardware has not and will not, return to Earth for forensic investigation to determine the cause of failure; but from what is known, the failures are consistent with rolling element bearing failures (Ref. 9). Although the Kepler mission produced some fantastic data and was fully successful in meeting its original 3½-year primary science goals, the impact of these failures was still considerable because it forced an early termination of the extended mission that began in November 2012 (Ref. 10). The Kepler team is currently reviewing useful science missions to repurpose the hardware, but the previously planned mission extension has been terminated.

The problems with these CMGs, gearboxes, vacuum pumps, and RWs were ultimately linked to the ball bearings and the ball-race rolling contact. Unfortunately, simply using noncontact-style hydrodynamic fluid film bearings does not ensure the avoidance of failure, as illustrated in the following paragraph.

In 2010, one of the ammonia cooling pumps on the ISS experienced a failure that has since been verified to be due to insufficient load capacity of one of the ammonia-lubricated carbon journal bearings. The failed bearing allowed the rotor to misalign in the housing, which caused severe wear on the bearings and eventual rubbing between the rotor and stator. The failure occurred 3½ years into the pump's 10-year design life, causing expensive early replacement and casting uncertainty on the life of the remaining in-service and spare pumps. The useful life of the ISS could be negatively affected because it cannot operate without at least one of the two cooling pumps.

With the trend of future spaceflight hardware requirements becoming more demanding, issues like those stated above will continue to be encountered. In addition, these bearing technologies are mature, with limited potential for evolutionary, much less revolutionary, performance increases. In order to extend beyond the current boundaries of spaceflight capabilities, it is timely to assess alternative technologies like electromagnetic levitation that may be better suited for some space mechanism applications. Some mission requirements may not be possible with heritage bearing technology, and in other applications new bearing technologies may have benefits that outweigh the risks, even when heritage technology could be used.

## **Magnetic Levitation Technology Assessment**

As an alternative to conventional rolling element and fluid film bearings, magnetic levitation (magnetic bearing) presents a rotor-support technology with the potential to mitigate some of the difficulties of space mechanism lubrication that accompany conventional technology. However, magnetic levitation is a complex mechanical-structural-electrical system and as such, brings forward new performance, reliability, and cost challenges. To quantify these challenges, and to help identify opportunities for investment, a suitability assessment is framed in the following paragraphs.

The goal is to have an understanding of whether magnetic levitation is feasible for future space applications based on technology readiness of all the major levitation subsystems, as well as mission-level requirements such as cost, weight, vibration, and so forth. If there are technological aspects that are not currently feasible, can they be made feasible, and what would be required to do so?

## **Technology Needs Assessment**

In its simplest form, a magnetic levitation system consists of a subsystem that generates a magnetic flux, a magnetically permeable rotor that reacts to the flux, a subsystem of sensors that measure rotor position and feed the information to a controller, and a control system that provides active input power to the flux generator. Each of these subsystems is made up of different materials and has different limitations and technological gaps between current capabilities and system requirements. For the sake of the current assessment, these subsystems are broken down into the following, somewhat arbitrary, categories: materials (structural, magnetic, and electrical), sensors, power electronics and controls, and actuators (motor/electrical coils design). Each of these categories has fundamental characteristics that affect performance parameters that determine the overall suitability of a levitation system to satisfy the needs of a space mechanism.

The following discussion is a brief summary of the relevant technologies and how they would participate in the development of a successful magnetically levitated mechanical system for space missions.

### **Materials**

Material selection is an important aspect of any engineering effort. For space applications it can be a difficult task because of the harsh and unusual environmental conditions experienced. Temperatures can be extreme at both ends of the spectrum—hot and cold—but also temperature ranges can be large. Radiation exposure can be a major consideration. Material response to vacuum conditions must be considered. Mass, and therefore material density, is always important for space applications. Often, the particular set of environmental constraints of a space mechanism results in material requirements that are at or beyond the cutting edge of current technology. In the case of a magnetic levitation system, the major material classes of concern in a magnetically levitated space mechanism are rotor structural materials, magnetic materials, and electrical materials. The rotor structural materials must be able to withstand the dynamic loads and environment (radiation, temperature, etc.), while providing the proper stiffness and durability with low mass. The magnetic materials (magnets, laminations, etc.) must provide sufficient flux density (for magnets) or magnetization (for laminations, etc.), and withstand environmental factors such as temperature, radiation, and so forth. They also must provide sufficient strength and exhibit low mass if they are installed on rotating structures. For electrical materials such as wire and insulation, the electrical resistance, temperature capability, embrittlement, density, and maximum current density are among the important characteristics. Part of the proposed assessment will focus on determining the material needs and what materials exist to fill those needs. If any gaps exist between what is needed and what is available, a determination of how to fill those gaps, if possible, will be offered.

### **Sensors**

Sensors are an important aspect of magnetically levitated systems. Active magnetic systems require feedback loops that include information such as speed, position, angle, temperature, and currents. Therefore, it is important to utilize or develop high-performance, small, and robust sensors for magnetically levitated space mechanisms. The assessment must include a survey of current sensor technologies and their ability to meet the demands of space mechanism applications. This is likely to be a technology area where an investment of resources is needed to satisfy current and future needs.

## **Electronics and Controls**

One potentially major drawback of magnetic bearings compared to rolling element bearings is the electronics and controls system needed to operate the bearings. Rolling element bearings are completely passive, so they do not require any intervention to operate properly. Magnetic bearings not only need sensors for feedback loops, but they require power to create the magnetic field for levitation of the rotor. The assessment will include an investigation into the power electronics and controls requirements and their system- and mission-level impacts. Learning how to utilize the best technology available to minimize the complexity, mass, volume, power consumption, and so forth, that is added by the magnetic bearing system and then comparing those costs to the benefits of the magnetic levitation versus a traditional rolling element bearing configuration is important. In addition, an appraisal of the expected life cycle of a magnetic bearing system versus a rolling element bearing system will factor into the cost-benefit analysis.

## **Actuators**

Actuators include such components as motors and generators as well as the electrical coils that make them possible and provide the levitation forces in bearings. Small, high-efficiency, high-reliability motors can increase the performance of space mechanisms for future applications. High-current-density, high-flux coils will also enable magnetic bearings with more capability in a smaller footprint. The assessment should include an investigation into current and future advances that can be made in the area of electric actuators to facilitate high-performance, magnetically levitated space mechanisms.

In addition to advances in basic coil technology, there are different types of motors (synchronous, switched reluctance, and inductance) and magnetic bearing types (homopolar and heteropolar). There are also different design strategies to reduce or eliminate certain drawbacks of a particular design (e.g., laminated rotors to reduce eddy current losses). A survey of the current types and techniques used in motors and bearings must be conducted as part of the assessment to determine which are suitable for magnetic space mechanisms.

## **Auxiliary Bearings**

Magnetic bearing systems typically require some type of auxiliary or backup bearing system to provide a safe shutdown in the case of a failure. Usually, the backup bearing system only needs to work for a short time while the rotating group decelerates from operating speed to zero. As such, the backup bearings can usually be simple and sacrificial. However, if continued operation of the particular actuator that failed is expected (e.g., to collect data for a set period time while it safely shuts down, or a restart is attempted after a recovery period), a more capable auxiliary bearing system would be needed. In either case, auxiliary bearings are an important aspect of magnetically levitated systems, and they must be considered in any trade study of magnetic bearings. Current backup bearing technology will be appraised in support of the effort to assess magnetic bearing space mechanisms.

## **Performance Requirements Assessment**

It is anticipated that magnetic bearing technology will not be the best solution for rotor support in every kind of space mechanism, nor on every mission for the same mechanism. To categorize magnetic bearings by what types of mechanisms and missions for which they might be feasible, their performance capabilities must be characterized.

## **Power**

Possibly the most critical design constraint for space mechanisms is the power requirement. Power in spacecraft is generally provided by solar collector arrays, which are limited in size roughly proportional to the size of the spacecraft; therefore, it is precious, especially as size decreases. For example, a typical small Earth observing satellite (~100-kg-size class) may generate on the order of  $1 \times 10^2$  W or less, of which 1 to 5 W might be available for a given subsystem such as an ACS (Refs. 11 and 12). The power required to magnetically levitate a given rotor may be the deciding factor of whether magnetic bearing technology is feasible for spacecraft mechanisms. Rolling element bearings require only enough power to overcome frictional losses. Magnetic bearings have no frictional loss, but do require power to generate levitating forces and maintain the electronics and controls systems. If magnetic bearing systems for an otherwise similar mechanism require more power than their rolling element counterparts, an engineering trade must be done to determine if the benefits justify the cost. Thus, part of the assessment should focus on the balance between how much power the spacecraft can generate and supply to the mechanism and how much power it requires. If the magnetic bearing system requires more power than what is available, it could be a showstopper for the technology. A further evaluation would be needed to determine if future advances could overcome the power gap and how close those advances are to being achievable.

## **Dynamics**

The dynamic environment plays a huge role in the design of the rotor support system in any rotating mechanism. The vibration environment determines the characteristics required of the bearing system to support the rotating hardware in a stable and controlled manner. In addition, the mechanism must survive the harsh vibration environment of launch, which may or may not require a launch-lock system. In the case of rotating space mechanisms, the vibration imparted back to the structure from the rotating component itself is also of utmost importance because it affects the spacecraft structure and any experiments or hardware on board. To be considered feasible, a magnetic-bearing-supported mechanism must be capable of meeting whatever requirements exist for smooth operation of the intended vehicle. Also of importance is the precision with which the bearings can maintain the position of the rotor. One element of the assessment will focus on characterizing the capabilities of current magnetic bearing technology to meet typical spaceflight dynamics requirements. If the capabilities fall short of the requirements, a determination of the possibility of improving the capabilities will be included.

## **Reliability**

Reliability is a performance requirement in the sense that any bearing technology chosen for spacecraft mechanisms must provide the life required for the mission. The reliability requirement is an area where magnetic bearing levitation may have a distinct advantage over the existing rolling element bearing technology for some applications. Magnetic bearings do not require lubrication and do not experience wear during operation, unlike rolling element bearings. Thus, they have the potential for much longer life cycles. The assessment should consider the reliability issue both from the standpoint of how much life is needed and how much life can be provided by magnetic levitation technology.

## **Cost**

Cost is usually not a primary concern for spacecraft mechanisms, but can be more important for some smaller missions with low budgets. Magnetic bearing technology is likely to be more expensive than current technology, but the assessment should determine how much more expensive and whether the added cost is justified for some missions for the potential gain in mission longevity.

## Density (Mass/Volume)

The volume required for a magnetic bearing system is almost certain to be larger than that of a similar rolling element bearing system because not only of the size of the bearing, but also the addition of the electronics and control systems required. The mass is likely to be larger as well for the same reason. It must be considered and weighed against the advantages to determine feasibility of magnetic bearing technology.

## Assessment Summary

As stated above, the technology and performance requirements must be assessed to determine the feasibility of magnetic bearing technology for space mechanisms. The information gained will help to populate the following tables on technology challenge areas and investment areas to enable engineers to design longer lasting, better performing space mechanisms in the future. Table I presents a list of technical challenge areas where the various bearing characteristics will determine which bearing technology offers the best solution for a given application. Rolling element bearings and journal bearings are included as references. In some areas it is unknown how magnetic bearings compare to the reference bearings in space mechanism applications. The proposed assessment will help answer those unknowns and feed data into the technology investment areas shown in Table II. Table III shows performance metrics, with room to add more as the assessment progresses, representing goals for each key technology area to enable advanced magnetic bearing space mechanisms.

TABLE I.—KEY TECHNOLOGY CHARACTERISTICS AND CHALLENGES

Characteristics	Bearings			
	Rolling element bearings	Sleeve bearings	Active magnetic bearings	Passive magnetic bearings
Power	Passive: requires power only to overcome friction	Passive: requires power only to overcome friction	Requires power to levitate rotor; no frictional power loss (in vacuum)	Requires no power (in vacuum)
Load capacity	Speed dependent: inversely proportional	Speed dependent: proportional	Constant: moderate	Constant: low
Stiffness and damping	Speed dependent: high stiffness, low damping	Speed dependent: high stiffness, high damping	Independent of speed: moderate stiffness, moderate damping	Independent of speed: low stiffness, no damping
Life	Moderate to high: limited by lubricant	Moderate to high: limited by lubricant	Unknown and potentially high: no wear during operation	Unknown and potentially high: no wear during operation
Reliability	High: benign failure modes	Moderate: some catastrophic failure modes, but avoidable	Unknown: requires backup system in case of power failure	Unknown
Cost	Low to moderate	Low to moderate	Unknown	Unknown
Volume	Low	Low to moderate	Moderate to high: inclusive of controller and electronics	Unknown
Weight	Low	Low	Unknown	Unknown

TABLE II.—KEY BEARING INVESTMENT AREAS

Investment area	Active magnetic bearings	Passive magnetic bearings
Materials	High-performance materials for flux density, strength, temperature, etc.	High-performance materials for flux density, strength, temperature, etc.
Sensors	Compact electronics for weight savings, high reliability, high accuracy, etc.	NA
Controllers	Better control algorithms: fault tolerant designs, active vibration control, etc.	NA
Power	Low power consumption schemes	NA
Others	To be determined	To be determined

TABLE III.—PERFORMANCE METRICS FOR KEY TECHNOLOGY AREAS

	Technology areas				
	Magnetic materials	Structural materials	Electric coil materials	Sensors and controller electronics	Other
Performance metrics	High flux capacity	High strength to weight	Low resistance	Low power consumption	TBD
	Low density	High corrosion resistance	High-and low-temperature insulation	Good thermal properties	
	Moderate strength	Radiation hardness	Radiation hardness	Radiation hardness	
	Good thermal properties	Good thermal properties	Low outgassing	Low outgassing	
	TBD	TBD	TBD	Small physical size	
				High accuracy	
			TBD		

### Technology Demonstration

As a means to further explore levitated mechanisms, a small-scale technology demonstration may be considered. In parallel with the proposed assessment, such a demonstration could highlight gaps between performance needs and technology capabilities. Example demonstrator units could include a low-viscosity-fluid pump similar to the ISS ammonia pumps or a small, satellite-sized CMG or reaction wheel assembly. The goal would be to take commercially available magnetic levitation technology and apply it to a current space mechanism application to demonstrate the viability of the concept. Modest scale (and cost) demonstrations of this type can serve to validate the conclusions that are drawn from engineering assessments based upon analysis and opinions alone without the added schedule and other pressures that accompany flight programs.

### Concluding Remarks

An assessment of magnetic levitation technology (magnetic bearings) for space mechanisms is proposed that will consider all aspects of system design and requirements. The proposed assessment would seek to utilize in-house NASA expertise to determine the feasibility of applying magnetic bearing technology to space mechanisms; specifically, attitude control system devices like reaction wheels and control moment gyroscopes (CMGs) as well as long-life motors. Magnetic levitation has the potential to

offer advantages over conventional technology by eliminating lubrication requirements, which can be challenging to meet in a space environment. There are possible hurdles to overcome, and if any of those hurdles are currently insurmountable, the assessment will determine the possibility of overcoming them in the near term with the technology breakthroughs that are on the horizon. A parallel technology demonstration is proposed to exhibit the capabilities and limitations of current magnetic levitation technology in common space mechanisms.

## References

1. Brändlein, Johannes, et al.: *Ball and Roller Bearings: Theory, Design and Application*. Third ed., John Wiley & Sons, New York, NY, 1999.
2. Booser, E. Richard, ed.: *CRC Handbook of Lubrication: Theory and Practice of Tribology*. Vol II, CRC Press, Boca Raton, FL, 1984.
3. Samuel, Alain; and Lechable, Bernard: *An Overview on Aerospace Magnetic Bearing Products for Spacecraft Attitude Control and for Industry*. ESA SP-381, 1997.
4. Morales, Winfredo; Fusaro, Robert; and Kascak, Albert: *Permanent Magnetic Bearing for Spacecraft Applications*. NASA/TM—2003-211996/REV1, 2008. <http://ntrs.nasa.gov>
5. Clark, Daniel J.; Jansen, Mark J.; and Montague, Gerald T.: *An Overview of Magnetic Bearing Technology for Gas Turbine Engines*. NASA/TM—2004-213177, 2004. <http://ntrs.nasa.gov>
6. Fusaro, Robert L., ed.: *NASA Space Mechanisms Handbook*. NASA/TP—1999-206988, 1999, pp. 235–270. Available from the NASA STI Program.
7. Roberts, E.W.: *Space Tribology: Its Role in Spacecraft Mechanisms*. *J. Phys. D: Appl. Phys.*, vol. 45, 2012, pp. 503001–503017.
8. Gurrisi, Charles, et al.: *Space Station Control Moment Gyroscope Lessons Learned*. NASA/CP—2010-216272, 2010. <http://ntrs.nasa.gov>
9. Overbye, Dennis: *Breakdown Imperils NASA's Hunt for Other Earths*. *New York Times*, May 15, 2013.
10. Harrington, J.D.; and Johnson, Michele: *NASA Ends Attempts to Fully Recover Kepler Spacecraft, Potential New Missions Considered*. NASA Release M13-58, Aug. 15, 2013.
11. Bialke, Bill: *A New Family of Low Cost Momentum/Reaction Wheels*. *Proceedings of the 15th Annual AAS Guidance and Control Conference*, Keystone, CO, 1992, pp. 171–188.
12. Scharfe, Michael, et al.: *The Challenges of Miniaturisation for a Magnetic Bearing Wheel*. ESA SP-480, 2001, pp. 17–24.





