

IAA-AAS-CU-20-XX-XX

PASSIVE THERMAL COATING OBSERVATORY OPERATING IN LOW-EARTH ORBIT (PATCOOL) – CUBESAT DESIGN TO TEST PASSIVE THERMAL COATINGS IN SPACE

Carlos Ojeda,^{*} Tanya Martin,[†] Sanny Omar,[‡] Michael Kennedy[§], Brandon Paz^{}, Riccardo Bevilacqua^{††}, and Brandon Marsell^{‡‡}**

The PATCOOL is a NASA sponsored, University of Florida developed 3U CubeSat meant to investigate the feasibility of using a cryogenic selective surface coating as a new, more efficient way of passively cooling components in space. Initial tests on the ground demonstrate that this coating should provide a much higher reflectance of the Sun's irradiant power than any existing coating, while still providing far-infrared power emission. The ultimate validation of this technology requires on-orbit testing. PATCOOL hosts a 4-sample housing, with the samples shaped as thin cylinders (coin-like). Two samples are coated with state-of-the-art material, while the other pair uses the new coating to be evaluated. The temperatures of all samples during the mission (minimum 72 hours of data collection) are measured via thermistors. The samples are connected via thin Kevlar strings to the housing, to minimize heat transfer. The housing is designed to shield the samples from Earth's thermal radiation, and the CubeSat is attitude stabilized and controlled via a gravity gradient boom, magnetorquers and a reaction wheel set. Thermal Desktop simulations show PATCOOL's ability to thermally isolate the samples from heat exchanges other than with Sun and deep space, thanks to its thermal design and the chosen attitude profile.

INTRODUCTION

For the past several decades, extensive research has been performed to study selective surfaces, which are materials whose thermal-optical properties are such that thermal radiation is emitted and absorbed predominantly in specific ranges of wavelengths, as opposed to the broad spectrum of emission and absorption typical of most standard materials and coatings.¹ In the 1960s, work by Hibbard and Liebert suggested a unique property of a specific selective surface; this material could

^{*} Post-Master's Associate, Mechanical and Aerospace Engineering, University of Florida, 939 Sweetwater Dr., Gainesville, FL 32611, USA.

[†] Graduate Student, Mechanical and Aerospace Engineering, University of Florida, 939 Sweetwater Dr., Gainesville, FL 32611, USA.

[‡] Post-Doctoral Associate, Mechanical and Aerospace Engineering, University of Florida, 939 Sweetwater Dr., Gainesville, FL 32611, USA.

[§] Undergraduate Student Researcher, Mechanical and Aerospace Engineering, University of Florida, 939 Sweetwater Dr., Gainesville, FL 32611, USA

^{**} Post-Bachelor's Associate, Mechanical and Aerospace Engineering, University of Florida, 939 Sweetwater Dr., Gainesville, FL 32611, USA

^{††} Associate Professor, Mechanical and Aerospace Engineering, University of Florida, 939 Sweetwater Dr., Gainesville, FL 32611, USA.

^{‡‡} Aerospace Engineer, NASA, Kennedy Space Center, FL, 32899, USA.

theoretically achieve and maintain a steady state temperature as low as 40 K when exposed to the orbital-thermal environmental conditions present in space at 1 AU from the Sun, or the distance of the Earth's orbit around the Sun.² This property, if functionally demonstrated, could enable unprecedented in-space capabilities, such as long-term on-orbit cryogenic propellant storage and superconductor operation on-orbit.³

The ADvanced Autonomous MUltiple Spacecraft (ADAMUS) Laboratory at the University of Florida (UF), with funding from NASA Launch Services Program (LSP), is currently developing a CubeSat, the PASSive Thermal Coating Observatory Operating in Low-earth orbit (PATCOOL), to serve as a platform to characterize the performance of experimental selective surface samples in a low-Earth orbit (LEO) environment. To characterize the experimental selective surface's performance on orbit, two small metallic samples coated with the experimental surface shall be prepared as well as two samples coated with the current state of the art in passive thermal coating technology. The temperature of these four samples will then be recorded over the mission duration of at least 72 hours and compared to assess the ability of the selective surface to achieve and maintain low temperatures in comparison to the current state of the art.

This paper discusses the design and planned operation of the PATCOOL CubeSat and mission, which shall involve the development and launch of a 3U CubeSat to serve as the testbed for the cryogenic selective surface in LEO. An overview of the CubeSat design, analysis, and component selection is provided, followed by a discussion of planned testing and qualification procedures for the PATCOOL CubeSat. Lastly, an overview of the mission including the success criteria and mission concept of operations is presented.

PAYLOAD SUMMARY

The PATCOOL CubeSat's primary payload is comprised of an aluminum housing containing four small aluminum samples. The samples are disks with a diameter of 25 mm and a thickness of 10 mm which are held to the housing with Kevlar string (chosen due to its high tensile strength and low thermal conductivity). Within the aluminum disks lies a thermistor to periodically measure the temperature of each sample during the mission. Two additional thermistors will be included to record the temperature at two other locations within the CubeSat to monitor the temperature response during the mission. Two of the aluminum disks are coated in an experimental cryogenic selective surface coating and the other two thermal samples are coated with AZ-93 white thermal paint, the current state-of-the-art passive thermal coating technology. The purpose of both coatings is to reflect radiant heat from the Sun while providing some far-infrared heat emission to maintain cryogenic temperatures, but off-the-shelf white thermal coatings still have significant absorption in nonvisible radiation bands. The goal of the experimental coating is to reach much lower temperatures than what is currently achievable with existing technology.⁴

The samples are housed within an in-house manufactured thermal sample housing or payload housing. This housing leverages aluminum's high conductivity to ensure that all four samples experience identical heat by radiation or conduction from the housing. It is also designed to minimize the conductive and radiative heat input to the samples from the CubeSat itself. It is important to note that the outside of the sample housing is painted in AZ-93, which allows the aluminum housing to radiate heat to deep space more effectively. An adapter made of Ultem serves as the interface between the PATCOOL housing and the CubeSat structure. Mounted atop the housing structure is a top cover with four circular cutouts for each sample, which is also coated in AZ-93. The payload components are shown in Fig. 1.

3U CUBESAT DESIGN

The PATCOOL CubeSat is designed to test the thermal samples when completely isolated from all sources of heat transfer aside from the Sun and deep space. A secondary objective is to test the ADAMUS Laboratory's drag de-orbit device (D3), which can modulate the drag area of a host CubeSat while maintaining passive 3-axis stabilization using aerodynamic and gravity gradient torques. The PATCOOL design will be manufactured completely in-house, but off the shelf components will be purchased from space heritage companies such as AAC Clyde Space, CubeSpace, BeagleBoard, and others, whenever possible. The PATCOOL design is comprised of the payload housing, CubeSat structure, deployables, solar panels, and avionics.

CubeSat Structure, Deployables, and Solar Panels

The PATCOOL CubeSat is designed to test the performance of the experimental selective surface for an application in LEO when exposed only to direct solar radiation and radiative heat exchange with deep space. This thermal environment emulates that which exists at an orbital distance of 1 *AU* from the Sun, neglecting the thermal loads incurred from the Earth and the internal heat generated from the CubeSat. A secondary objective is to test a novel attitude control system developed by the ADAMUS Laboratory, which incorporates a modified drag de-orbit device (D3) to serve as a gravity gradient boom. The components of the PATCOOL CubeSat will be primarily manufactured in-house; however, off the shelf components will be purchased from vendors with space heritage, such as AAC Clyde Space, CubeSpace, and BeagleBone among others, whenever possible.

The PATCOOL design utilizes a 3U structure to house its avionics, deployables, and payload. The vertical dimension of the structure adheres to Cal Poly's standardized CubeSat deployment system for 3U CubeSats of 340.5 *mm*.⁵ Mission requirements specify that the CubeSat's attitude be controlled to orient it in such a way that the payload is protected from any radiative heat transfer other than with the Sun and deep space. Therefore, the design of the CubeSat structure takes an asymmetric shape to ensure that only one side continually absorbs all radiation while the other side rejects heat (see Fig. 2). As shown, the CubeSat structure has an asymmetric cut in the upper location where the payload housing is. However, it is important to note that the payload housing is isolated from all heat captured by the CubeSat and produced from the avionics. This is done by the payload housing adapter which is made from Ultem plastic. This adapter is made so that the payload housing does not physically touch the CubeSat structure at all. In addition to the payload housing, the design utilizes multi-layer insulation (MLI) sheets to protect the payload housing from radiative heat in the upper portion of the CubeSat.

This design incorporates two deployable operations: The magnetometer and the tip mass, which deploys via the D3. The magnetometer deploys after detumble to quantify Earth's magnetic field, which helps the magnetorquers actuate appropriately. A tip mass is positioned at the bottom of the CubeSat and it is attached to a retractable tape-spring boom that serves to de-orbit the satellite after 25 years per NASA requirements.⁶ The boom and tip-mass deploy one meter out of the CubeSat. By modulating the drag area of the satellite, orbital maneuvering can be performed, and the satellite can de-orbit to a desired location. The tip mass and the boom create an aerodynamic and gravity gradient torque that allows the satellite to de-tumble and burn on re-entry, preventing the satellite from being a hazard to ground or space assets.⁷

Standard 3U and 2U solar panels manufactured by Clyde Space are used for this mission. The 3U solar panels are located on the sides where the asymmetric cut on the 3U CubeSat structure is not located on, while the 2U solar panels are located on the sides where the cut is also on. The solar panels and their respective locations on the PATCOOL CubeSat design are shown in Fig. 2.

Avionics

Commercially available avionics are used in the PATCOOL satellite with the exception of two custom-made driver boards: one to contain the thermistor circuit and mount the transceiver, and the other to contain the BeagleBone Black processor and control the D3 device.

COTS Avionics. The commercial off-the-shelf (COTS) avionics are shown in Fig. 3 and include the Iridium 9602 Transceiver, the Pulse W3228 Ceramic Patch Antenna, the Clyde Space 3G EPS and 20 Whr Battery, the BeagleBone Black processor, the CubeSpace Attitude Determination and Control System (ADCS), four Clyde Space solar panels, and six Cernox CX-SD 1070 thermistors. These components were chosen for their flight heritage and ease of integration with hardware. The battery, EPS, ADCS are compatible with one another using PC104 headers and will be connected to the custom-made boards via PC104 header as well. The CubeSpace ADCS contains the magnetometers and magnetorquers to perform attitude stabilization.

Custom-Made PCBs. The satellite will include two custom-made PCBs. One of which will host the BeagleBone Black and will serve as the driver board for the D3 device. It will also contain two TI SN754410 quad half h-bridge chips to control the D3 deployer motor and a cable connector to route signals from the D3 board to the stepper motor. The other board will contain the thermistor circuit as well as the transceiver its connector to the board, since that and the antenna are the only components of the satellite that are not PC104 compatible. The antenna is a patch with an adhesive that can stick to the side of the CubeSat structure and use a wire to connect with the avionics stack-up. The two custom made PCBs will interface with the battery, EPS, and ADCS using PC104 headers.

Mass, Power, and Financial Budget

The Cal Poly CubeSat mechanical requirements state that the maximum mass of a 3U CubeSat shall be 4 kg. The total mass of the PATCOOL 3U satellite is 3.4 kg, which satisfies the mass requirement. The CAD model of the full satellite assembly in SOLIDWORKS was used to verify center of mass requirements. The mass budget is shown in Table 1. Table 2 denotes the power consumption of each control mode of the satellite during the 72-hour mission during both nominal and maximum cases.

ANALYSES

Detailed Power Analysis

AGI's System's Toolkit (STK) was utilized to model a mockup of the PATCOOL CubeSat and its solar panels to simulate the power generated by the solar panels while orbiting the Earth in an ISS orbit (400 km circular at 51.9° inclination and 0° right ascension of ascending node) with the attitude constraints of the PATCOOL mission enforced. These constraints include maintaining one face of the CubeSat to be pointing towards the local nadir at all times as well as maintaining the CubeSat edge between the two 3U solar panels to be always pointing towards the Sun. To evaluate the power consumed versus power generated, a nominal power-draw as well as a worst-case scenario power -draw, including solar panel efficiencies of 26.7%, and a power draw equal to the maximum possible for all components were considered.

The data for power generated over the course of three days were inputted into Excel and combined with the worst-case power draw per time step to produce a plot as presented in Fig. 4, which shows the battery charge over a period of four days following the orbital epoch. It is shown that the battery never discharges below 80% as recommended by the supplier to prevent possible damage to the battery cells.

Table 1. Table of CubeSat Components with Masses and Cost

Component	Quantity	Mass (kg)
Thermal samples	4	0.052
Thermistor	6	0.000
Analog to digital converter chip	1	0.000
Constant current chip	6	0.000
Resistors for current chips	12	0.001
H-bridge driver chip	1	-
PC104 pin header	2	-
Spectra strings	1	0.000
Multilayer insulation	1	0.002
Beagle Bone Black Industrial + Board	1	0.096
Iridium 9602 Transceiver + Board	1	0.057
Pulse W3228 Ceramic Patch Antenna	1	0.010
CubeSpace CubeADCS 3-Axis	1	0.530
D3 Deployer	1	0.239
Deployer Tip Mass	1	0.500
Clyde Space 3G EPS	1	0.086
20Whr CubeSat Battery	1	0.160
Clyde Space 3U Solar Panel	1	0.276
Clyde Space 2U Solar Panel	2	0.184
3U CubeSat structure	2	0.629
Avionics/flight stack adapter	0	0.122
Sample housing	1	0.156
Housing adapter	1	0.169
Housing cover	1	0.039
Heat shield	1	0.058
Total		3.366

Table 2. CubeSat Power Budget

Control Modes	Component	Nominal Case			Maximum Case		
		Voltage (V)	Current (A)	Power (W)	Voltage (V)	Current (A)	Power (W)
Detumble	EPS	-	-	0.200	-	-	0.200
	Battery	-	-	0.100	-	-	0.100
	BeagleBone	5.000	0.210	1.050	5.000	0.210	1.050
	CubeComputer	-	-	0.200	-	-	0.200
	CubeSense S	-	-	0.100	-	-	0.200
	CubeTorquer	2.500	0.150	0.375	2.500	0.150	0.375
	Tranceiver	5.000	0.035	0.175	5.000	0.170	0.850
	Total Power (W)	-	-	2.200	12.500	0.530	2.975
Pointing	EPS	-	-	0.200	-	-	0.200
	Battery	-	-	0.100	-	-	0.100
	BeagleBone	5.000	0.210	1.050	5.000	0.210	1.050
	CubeComputer	-	-	0.200	-	-	0.200
	CubeSense S	-	-	0.100	-	-	0.200
	CubeWheel S	-	-	0.150	-	-	0.650
	Tranceiver	5.000	0.035	0.175	5.000	0.170	0.850
	Total Power (W)	-	-	1.975	-	0.380	3.250
Science	EPS	-	-	0.200	-	-	0.200
	Battery	-	-	0.100	-	-	0.100
	BeagleBone	5.000	0.210	1.050	5.000	0.210	1.050
	Thermistor circuit	5.000	0.001	0.005	5.000	0.001	0.005
	CubeComputer	-	-	0.200	-	-	0.200
	CubeSense S	-	-	0.100	-	-	0.200
	CubeWheel S	-	-	0.150	-	-	0.650
	CubeTorquer	2.500	0.150	0.375	2.500	0.150	0.375
	Tranceiver	5.000	0.035	0.175	5.000	0.170	0.850
Total Power (W)	-	-	2.355	17.5	0.531	3.630	

Link Analysis

AGI's STK was utilized to assess the CubeSat's ability to maintain contact with the Iridium communication satellite constellation. For the purpose of a worst-case analysis, a standard antenna with an efficiency of 50% (the actual antenna's efficiency is roughly 84%) was modelled, and the number of satellites in the Iridium constellation with which contact was maintained over time was plotted as shown in Fig. 5. The bit error rate was also 1.17×10^{-17} on average throughout a four-day period. There were never fewer than six contacts within the constellation over the time analyzed. With such a high link margin even in the worst-case scenario, the team can be confident that reliable communication may be maintained between the CubeSat and the operators on Earth at any time during the mission via the Iridium constellation.

Orbital Analysis

AGI's Systems Toolkit was utilized to perform orbital analyses for the PATCOOL CubeSat in a space station orbit (400 km circular at 51.9° inclination and 0° right ascension of ascending node) to estimate the operational lifespan of the satellite in orbit. Using a drag coefficient of 2.2, a mass of 3.5 kg, and a drag area of 0.04 m², the time to decay was computed for the satellite using a January 1, 2021 orbital epoch as well as epochs at July 1, 2021, January 1, 2022, and July 1, 2022. These dates were chosen to provide a variety of possible solar conditions possible during a prospective mission.

The shortest orbital duration for the satellite was 307 days, or 4815 orbits, when launched on July 1, 2022. The longest duration was achieved at approximately 1.5 years, or 8758 orbits, when launched on January 1, 2021.

Thermal Analysis

For the PATCOOL mission, it is imperative that the thermal behavior of the CubeSat during operation be well-understood such that proper thermistors may be acquired for data collection. Furthermore, the temperature distribution within the CubeSat must be enforced, to the extent possible, such that all the experimental samples within the payload experience the same thermal loading conditions; this property can be computationally verified by performing a detailed thermal analysis. Thus, a comprehensive thermal analysis was performed using Thermal Desktop to simulate the anticipated orbital-thermal case. This process allowed for robust and accurate modelling of the CubeSat and of the orbital-thermal environment in a simulation environment such that the temperature response over time within the CubeSat could be quantified.

To reduce the computational cost of performing thermal simulations, a simplified model of the PATCOOL CubeSat was created within Thermal Desktop, shown in Fig. 6. An ISS orbit was then imported to Thermal Desktop to define the orbital-thermal environment the CubeSat would encounter. A representation of this orbit is shown in Fig. 7. A simulation was then performed to assess the temperature response within the thermal samples and the CubeSat sample housing component over the anticipated duration of the PATCOOL mission of 72 hours, or 259,200 seconds. The results of this analysis are shown in Fig. 8. From the simulations, it is demonstrated that the temperature of the samples coated with the experimental selective surface reach the lowest temperature out of the entire CubeSat system at 166.1 K, and the CubeSat housing component and white-painted samples achieve higher temperatures of 199.6 K and 212.2 K respectively.

TEST PLAN AND PROCEDURES

According to LSP Dispenser and CubeSat Requirements (LSP-REQ-317.01), the PATCOOL CubeSat will require shock, vibration, and thermal vacuum (TVAC) testing.⁸ To simulate the launch environment, the CubeSat and dispenser must be tested to four times the maximum predicted

shock, sinusoidal vibration, and random vibration. Since the launch platform has not yet been determined, the vibration values for now will depend on the likely scenario that a NanoRacks dispenser will be used to deploy from the International Space Station (ISS).⁹ Preliminary vibration testing has shown that the spacecraft design concept is sound and can withstand the required shock and vibration test levels of 9.47 grms for one minute along each axis. A photograph of the preliminary vibration testing is shown in Fig. 9. Additionally, the CubeSat must be brought to a temperature greater than 70°C and a pressure less than 10⁻⁴ Torr simultaneously as part of the TVAC test which will ensure that the satellite will operate properly in the space environment. After thermal stabilization, the CubeSat must be maintained at that temperature and pressure for at least three hours.

An operational test will be performed on the CubeSat after the shock, vibration, and TVAC testing to ensure that it will still perform nominally after launch. Hardware in-the-loop testing will be formed to verify the functionality of the avionics hardware and flight software, attitude determination and control and temperature readings. The ClydeSpace battery and EPS will be acceptance tested comprehensively to verify their performance. If in-the-loop testing is successful, then the radio will be tested to ensure that the ground station is properly configured for data uplink and downlink, and to verify the connection to and from the CubeSat.

MISSION CONCEPT OF OPERATIONS

Fig. 10 illustrates the phases of the mission and the requisite criteria for each phase. The PATCOOL CubeSat will have the ability to receive and execute commands from operators on Earth during the mission. This capability will allow for diagnosis and correction of the CubeSat software through patches if any issues arise during the mission. Presently, PATCOOL is intended to deploy from the International Space Station (ISS) from a NanoRacks deployer, and the CubeSat has been designed accordingly. However, to accommodate any potential deployment configuration, the CubeSat designers have consulted the Cal Poly CubeSat Design Specification, which is generally the most stringent CubeSat standard, in the design of the PATCOOL CubeSat. Accounting for a launch from the ISS, the team plans to apply to the CubeSat Launch Initiative (CSLI) to acquire funding for launch and deployment of the PATCOOL CubeSat.

MISSION SUCCESS CRITERIA

The primary goal of the PATCOOL mission is to characterize and demonstrate the performance of the experimental selective surface as a passive thermal coating, and as such the success of the mission is largely contingent upon the successful thermal isolation of the experimental samples from the Earth's and the CubeSat's thermal influences, and the recording and transfer of the samples' temperature data during the mission. Fig. 11 demonstrates the individual mission success criteria and their respective quantitative weight towards the overall success of the mission.

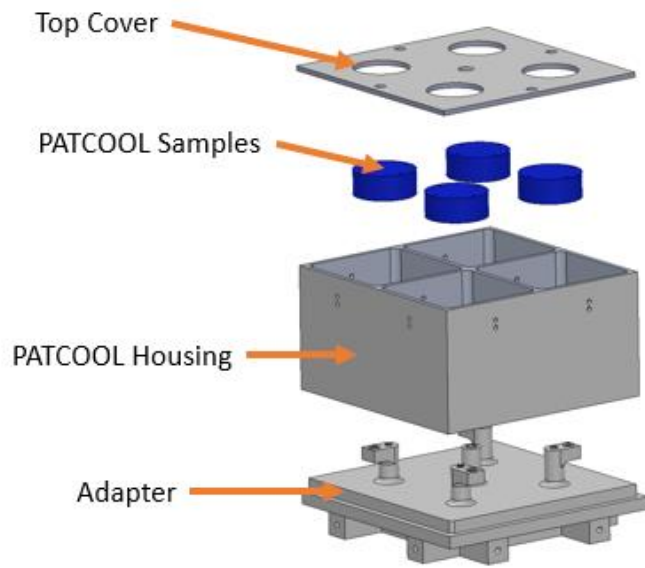

Figure 1. PATCOOL Payload and CubeSat Adapter

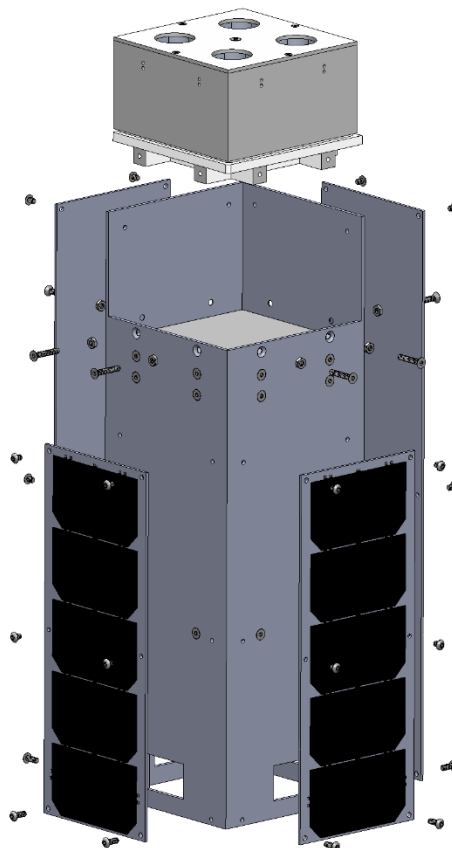

Figure 2. PATCOOL Structure and Payload with Solar Panels

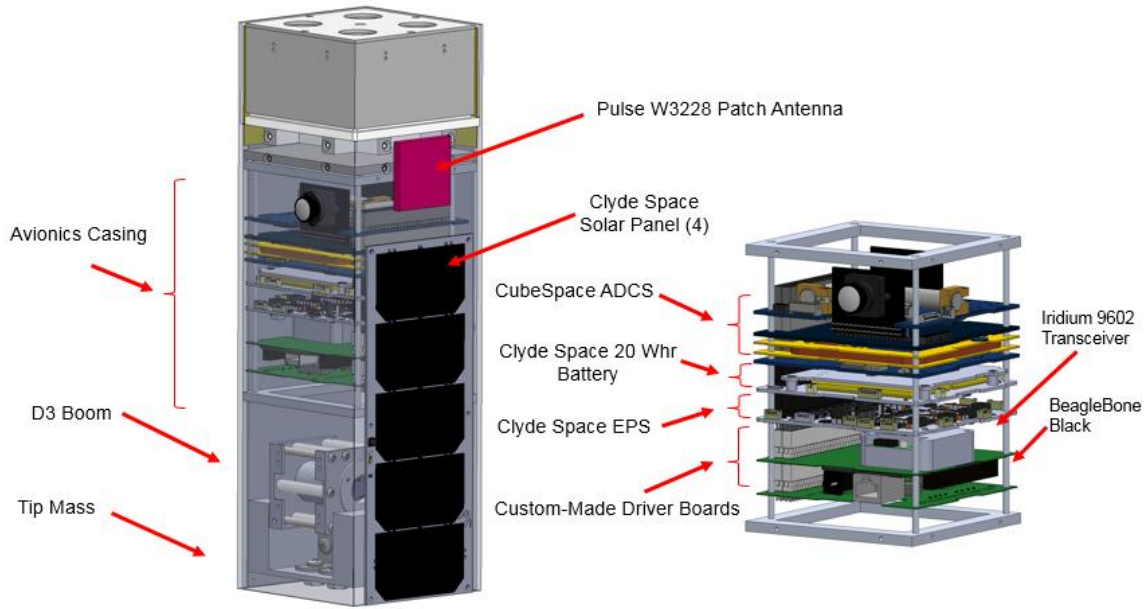

Figure 3. Avionics Components and Interfacing

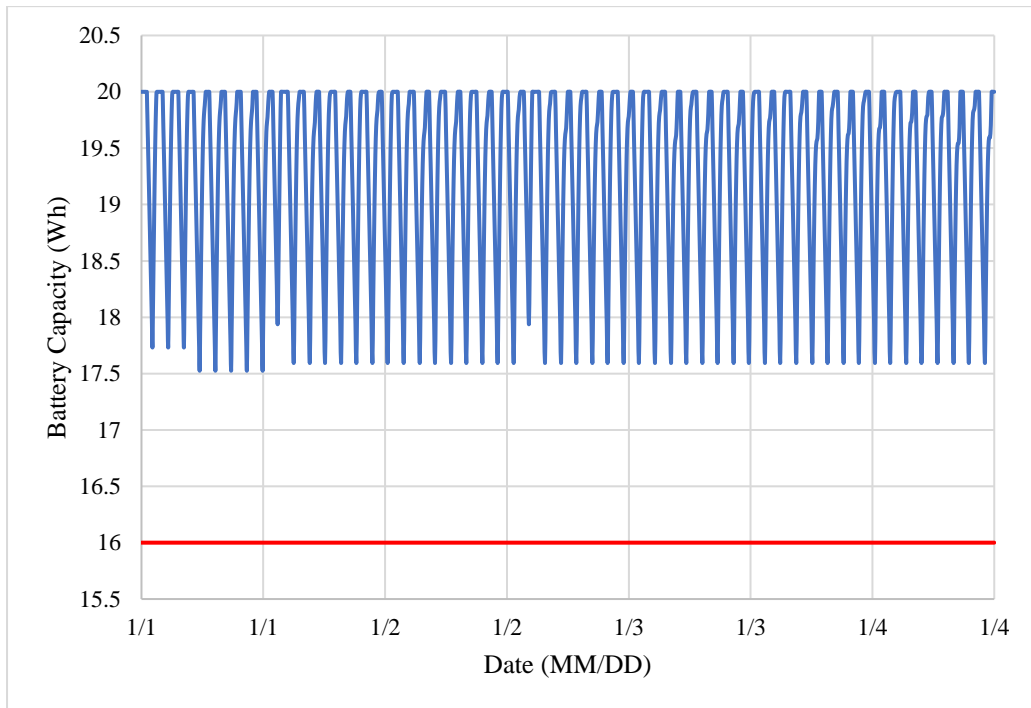

Figure 4. COTS ADCS Worst-Case Battery Capacity, RAAN = 0 deg

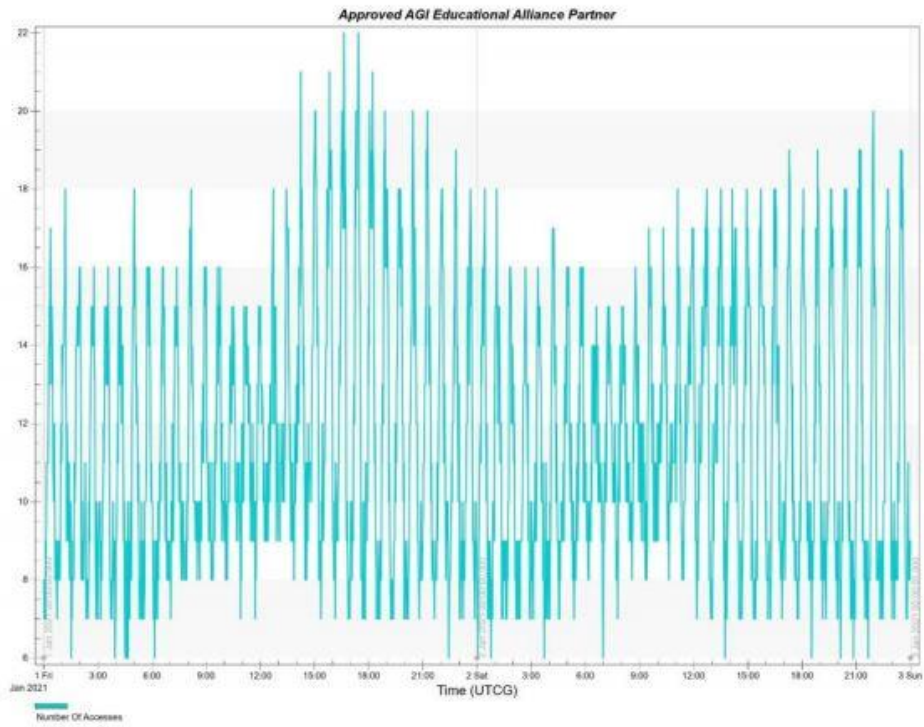

Figure 5. STK Link Assessment

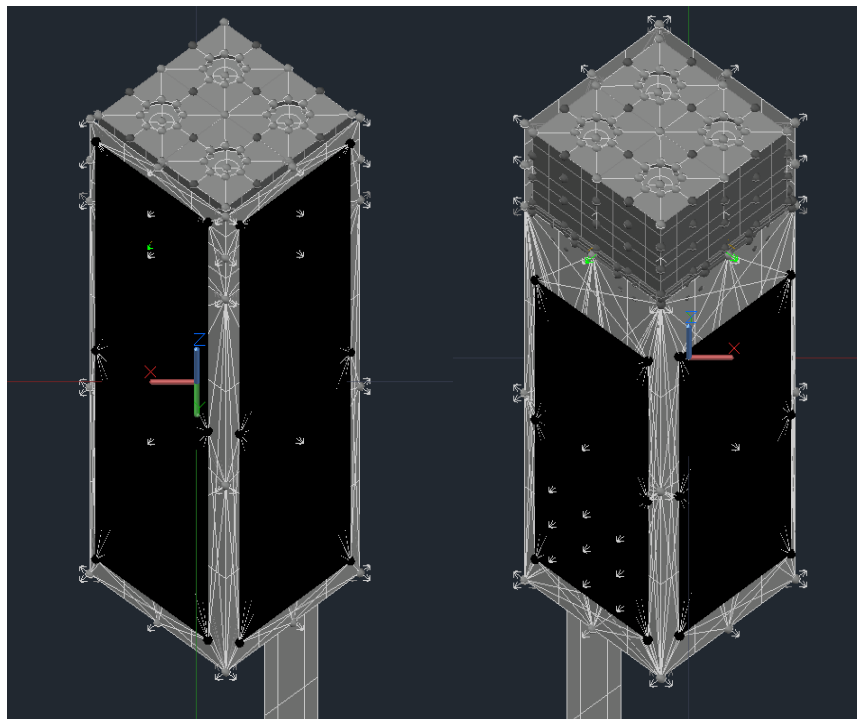

Figure 6. Simplified PATCOOL CubeSat Model for Thermal Analysis

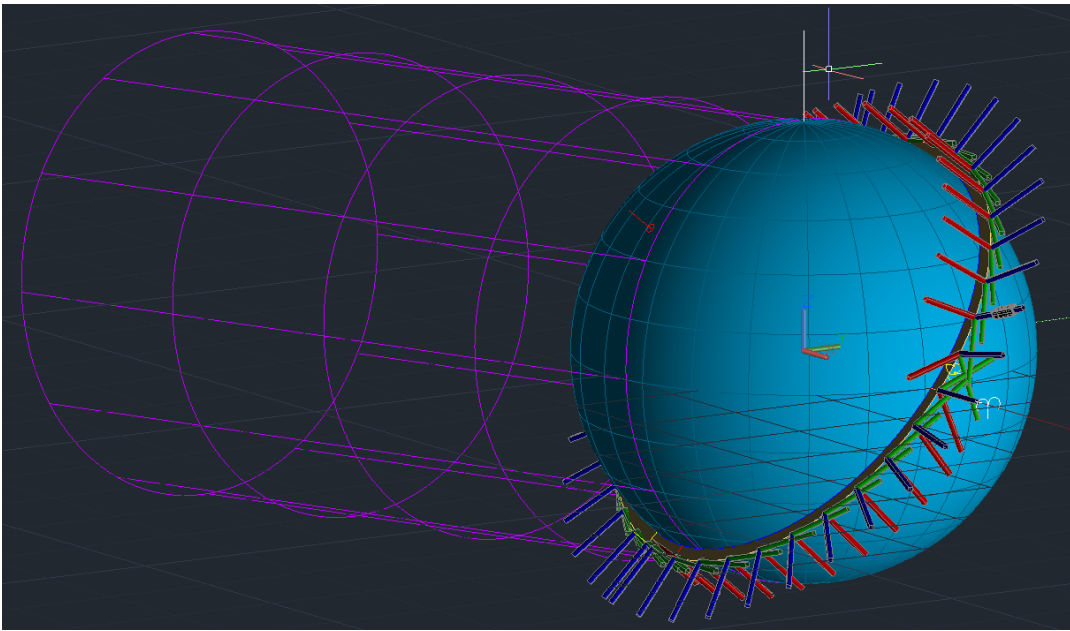

Figure 7. ISS Orbit Used for Thermal Analysis in Thermal Desktop

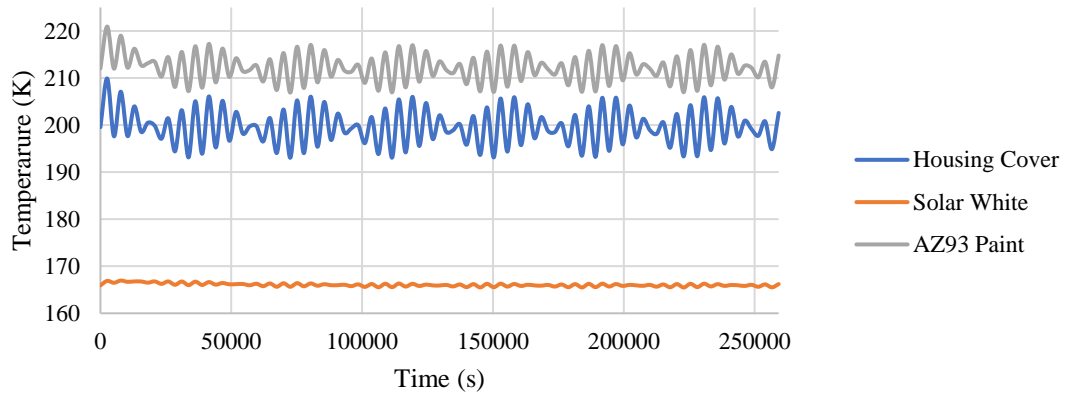

Figure 8. PATCOOL Temperature Response over Time

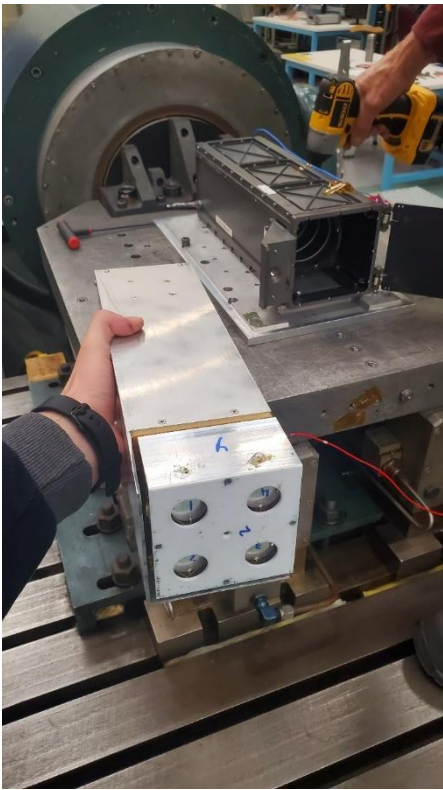

Figure 9. Vibration Testing of the PATCOOL CubeSat Prototype

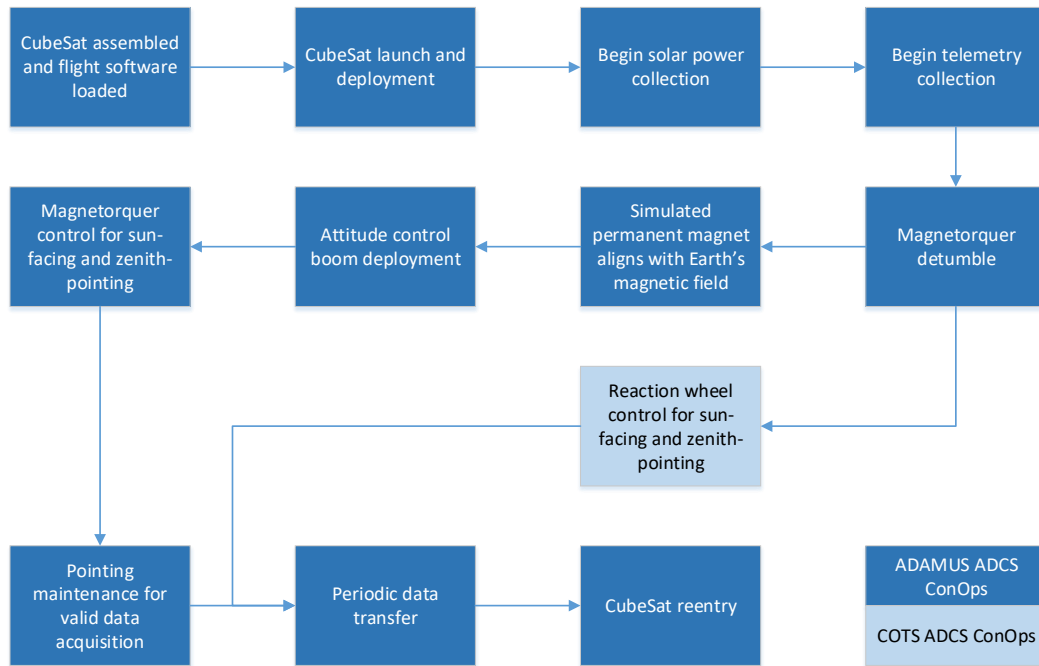

Figure 10. PATCOOL Mission Concept of Operations

PATCOOL shields samples from direct Earth heating (20%)	After detumbling and initial pointing are achieved, attitude control continuously prevents sample-Earth view factor (20%)
	Secular temperature trend for samples is net negative towards steady state (5%)
PATCOOL minimizes heat transfer from CubeSat to samples (10%)	Increase success by 1% for each 10K of temperature differential between samples and housing over $\Delta T = 50K$ (5%)
	CubeSat is detectable and responsive (operational) within 1 hour of deployment (9%)
PATCOOL has an operational life of 72 hours (30%)	CubeSat operation is continuous for at least 54 minutes per hour (3%)
	Increase success by 1% for each two-hour period CubeSat is operational over 36 hours
PATCOOL sends all temperature data back to Earth (40%)	Data stream has at least 10 data points per hour per sample (4%)
	Increase success by 1% for each hour data received over 36 hours

Figure 11. PATCOOL Mission Success Criteria

CONCLUSION

This paper presents the design of the PAssive Thermal Coating Observatory Operating in Low-earth orbit (PATCOOL) mission, which will incorporate a 3U CubeSat to characterize and demonstrate the performance of an experimental selective surface as a passive thermal coating for in-space applications. The CubeSat will use commercially available components for the avionics, antennas, and MLI blanket while the PATCOOL payloads and adapters, D3 device, CubeSat and avionics structures, and tip mass will be manufactured externally and assembled in-house. The use of space tested avionics boards will increase reliability of the satellite and increase the chance of mission success. After launch, the spacecraft will perform thermal measurements of thermal coatings in space and demonstrate the operation of the drag device and tip mass concept to perform controlled re-entry using aerodynamic drag. After a successful mission, it should be possible to passively cool a component to significantly low temperatures and store cryogenics in space for an extended period of time.

ACKNOWLEDGMENTS

The authors would like to thank a.i. solutions for sponsoring a NASA Kennedy Space Center subcontract (LSP-19-003, Highly Reflective Coating CubeSat), as well as the team at NASA LSP for their generous support of this project.

REFERENCES

- ¹ C.G. Granqvist, "Radiative heating and cooling with spectrally selective surfaces", *Applied Optics*, Vol. 20, Issue 15
- ² Liebert, C., and Hibbard, R., "Performance of spectrally selective collector surfaces in a solar-driven carnot space-power system", *Solar Energy*, Vol. 6, No. 3, 1962.
- ³ NASA Launch Services Program, "CubeSat Design to Test Passive Thermal Coatings in Space", LSP-19-003, Highly Reflective Coating CubeSat, 2019.
- ⁴ Youngquist, R., and Nurge, M., "Cryogenic Selective Surfaces Final Report on a Phase I NIAC Study", NASA Kennedy Space Center, 2016.
- ⁵ Cal Poly SLO, "CubeSat Design Specification," 2014.
- ⁶ NASA, "Process for Limiting Orbital Debris," Tech. Rep. NASA-STD-8719.14A, May 2012.
- ⁷ Omar, S., Guglielmo, D., Bevilacqua, R., "DRAG DE-ORBIT DEVICE (D3) MISSION FOR VALIDATION OF CONTROLLED SPACECRAFT RE-ENTRY USING AERODYNAMIC DRAG", IAA CubeSat Conference, Rome, Italy, Dec. 2017.
- ⁸ NASA, "Launch Services Program CubeSat Requirements," 2014.
- ⁹ L.L.C. NanoRacks, "NanoRacks CubeSat Deployer (NRCSD) Interface Control Document," 2013.