



L Y N X X - R A Y O B S E R V A T O R Y

— RESPONSE *to the* FIRST —
ASTRO 2020 DECADAL SURVEY
REQUEST *for* INFORMATION
— 22 NOVEMBER 2019 —



I N T R O D U C T I O N

This document serves as the *Lynx* Team's response to the first Request For Information (RFI) from the 2020 Decadal Survey in Astronomy and Astrophysics. Detailed answers to all of the questions asked in this RFI can be found in the *Lynx* Concept Study Report, Supplementary Technology Roadmaps, and the *Lynx* Cost Book.

Lynx Concept Study Report (hereafter "the Lynx Report")

WWW.LYNXOBSERVATORY.ORG/REPORT

Lynx Technology Roadmaps

WWW.LYNXOBSERVATORY.ORG/ROADMAPS

Note that the above URL provides a redacted version of Technology Roadmaps to remove competition-sensitive material on specific technologies, schedule, and cost information. Unredacted versions are available upon request.

Lynx Cost Book

Non-public. Distributed to TRACE and Astro2020 Panels.

Lynx MEL+PEL

Lynx_MEL_PEL.xlsx attached to this RFI response.

Lynx DRM Project Schedule

Lynx-DRM-Project-Schedule.pdf attached to this RFI response.

Lynx DRM Supplement Design Package

Available upon request.

* * *

EXECUTIVE SUMMARY
QUESTION 1

Summarize your science objectives and your technical implementation at a high level.

Lynx is designed to pursue three fundamental science pillars:

1. Seeing the dawn of black holes,
2. Revealing what drives galaxy formation and evolution, and
3. Unveiling the energetic side of stellar evolution and stellar ecosystems.

Lynx will operate as an X-ray observatory with a grazing incidence telescope and detectors that record the position, energy, and arrival time of individual X-ray photons. Post-facto aspect reconstruction leads to modest requirements on pointing precision and stability, while enabling very accurate sky locations for detected photons. *Lynx* will operate in a halo orbit around Sun-Earth L2, enabling high observing efficiency in a stable environment. Its maneuvers and operational procedures on-orbit are nearly identical to that of the *Chandra X-ray Observatory*, and similar design approaches promote longevity.

A detailed response to this question is given in the [Lynx Report, Executive Summary, pp. 2–14](#).



EXECUTIVE SUMMARY
QUESTION 2

Summarize the technology maturity of your implementation, listing the demonstrated technologies and the technologies requiring development.

The *Lynx* spacecraft requires no new inventions. Its design is straightforward, with few moving parts; all of its elements can be procured today. The transformational scientific power of *Lynx* is entirely enabled by its payload — the mirror assembly and a suite of three highly capable science instruments.

Significant U.S. investments over the past 10–15 years have led to recent breakthroughs and sustained maturation of key *Lynx* technologies for X-ray mirrors and detectors. Each of the payload elements features state-of-the-art technologies, but at the same time represents a natural evolution of an existing instrument or technology, with each already having years of funded technology development. Key technologies are currently at Technology Readiness Levels (TRL) 3 or 4. With three years of targeted pre-phase A development in early 2020s, three of four key technologies will be matured to TRL 5 and one will reach TRL 4 by start of Phase A, achieving TRL 5 shortly thereafter.

The [Lynx Report](#) ([Executive Summary](#), pp. 7–12) gives a detailed high-level summary of the technical maturity of the Mirror Assembly and three science instruments: the High-Definition X-ray Imager, the *Lynx* X-ray Microcalorimeter, and the X-ray Grating Spectrometer.

EXECUTIVE SUMMARY
QUESTION 3

Summarize areas where the data to support this RFI are not currently available.

Information is unavailable for Cost Question #1: *Provide FTE estimates and cost by year/Phase for science personnel.* The parametric estimate, which is the primary cost estimate for *Lynx* given its pre-formulation level of maturity, does not specifically provide FTE levels. Portions of the grassroots estimate, specifically those for prime contractor efforts, operations, and science instruments included estimated manpower. These details are included in the [Cost Book](#). A true bottoms-up cost assessment with FTE estimates will be developed in the late pre-Phase A / early Phase A timeframe.



SCIENCE OVERVIEW QUESTION 1

Briefly describe the scientific objectives and the most important measurements required to fulfill these objectives. Feel free to refer to science whitepapers or references from the literature.

The science objectives and most demanding measurements are fully documented in [Lynx Report, §5 \(pp. 93-98\)](#), with references provided to the science narrative within the report and to the literature. A brief summary of science objectives within each of the *Lynx* pillars is given below:

Science Pillar 1: The Dawn of Black Holes

1.1. Observe progenitors of supermassive black holes at their seed stage at $z = 10$ ([Lynx Report, §1.1](#)). The key measurement is deep X-ray surveys reaching flux limits of $\sim 1 \times 10^{-19}$ erg/s/cm² over an ~ 1 deg² survey area, as required to detect a sufficient number of black holes with mass $\sim 10,000 M_{\text{solar}}$ at $z = 10$

1.2. Observe the growth of supermassive black holes from Cosmic Dawn to the Present ([Lynx Report, §1.2](#)). The key measurement is surveys down to $\sim 2 \times 10^{-18}$ erg/s/cm² over several square degrees to track the evolution of the X-ray luminosity function and clustering properties of AGN.

1.3. Observed relics of the supermassive black hole seeds in the Local Universe ([Lynx Report, §1.3](#)). The key measurement is a serendipitous survey of nearby dwarf galaxies to constrain the occupation fraction of accreting intermediate-mass black holes.

Science Pillar 2: The Drivers of Galaxy Evolution

2.1. Determine the state of diffuse baryons in galactic halos to guide the galaxy formation models ([Lynx Report, §2.1 and Appendix A.5](#)). Key measurements include reaching a 10% accuracy for derived thermodynamic parameters of hot gas in galactic halos as $\sim 1/2$ of the virial radius via direct imaging observations, and measurements of the chemical and kinematic structure of the hot halos at \sim the virial radius via absorption line spectroscopy of background AGNs. The required sensitivities are $\sim 3 \times 10^{-22}$ erg/s/cm²/arcsec² for direct imaging in the 0.7-1.1 keV band, and ~ 1 mÅ equivalent width for the OVII and OVIII absorption lines.

2.2. Establish the energetics, physics, and the impact of energy feedback on galactic scales. The required observations include resolving the spatial and spectral structure of starburst-driven winds in low-redshift galaxies ([Lynx Report, §2.2](#)), determining the effects of AGN energy feedback on the ISM, and determining the physical state of gas near the SMBH sphere of influence in nearby galaxies ([Lynx Report, §2](#)).

Answer continued on next page

Response to **Science Overview** Question 1 (*continued*)**Science Pillar 3: The Energetic Side of Stellar Evolution and Stellar Ecosystems**

3.1. Complete census of young stars in active star forming regions in the Milky Way ([Lynx Report, §3.1](#)). Typical observations are imaging surveys down to 3×10^{-19} to 1.3×10^{-18} erg/s/cm², as required to reach stellar mass limits $\sim 0.1 M_{\text{solar}}$ in a typical range of distances.

3.2. Fundamental physics of stellar coronae, accretion, and winds ([Lynx Report, §3.2](#)). Typical observations are a detailed spectroscopic survey of 80 stars within 10 pc with X-ray gratings, and transit spectroscopy of planets around dwarf stars down to super-earth regime.

3.3 Detailed studies of supernova remnants in the Milky Way and nearby galaxies, with the data quality sufficient to constrain explosion models and the impact of SN-generated feedback on the star formation activity ([Lynx Report, §3.3](#)). Typical observations include establishing a detailed 3D structure of the Milky Way remnants, and surveys of SNRs in the Local Group galaxies.

3.4 Detailed statistics of X-ray binaries in the nearby galaxies ([Lynx Report, §3.4](#)).

**SCIENCE OVERVIEW
QUESTION 2**

Of the objectives, which are the most demanding? Why?

The most demanding of the science objectives above are documented in the [Lynx Science Traceability Matrix](#) ([Lynx Report, §5, p. 97](#)). A short summary is provided below:

Objective 1.1. *Deep surveys for $z=10$ black hole seeds* is the most demanding in terms of sensitivity limits and the sky coverage for surveys. This sensitivity goal drives the requirements on the telescope grasp (effective area times the field-of-view with sub-arcsecond imaging) and, indirectly, on the angular resolution (to avoid source confusion).

Objective 2.1. *Direct imaging of galactic halos* is the most demanding observation in terms of the telescope effective area and internal background of the imaging instrument because it requires reaching extremely low levels of the X-ray surface brightness for diffuse emission. Absorption-line studies of galactic halos are the most demanding in terms of spectral resolution ($R > 5000$) and throughput for the X-ray Grating Spectrometer.

Objective 2.2. *Feedback observations on the galactic scales* require spatially-resolved high-R spectroscopy --- a capability that can be provided only with an X-ray microcalorimeter instrument. Observations of galactic winds require a uniquely high resolving power in the soft X-ray band ($R \sim 2000$), while studies of the AGN feedback require a uniquely high spatial resolution ($\sim 0.5''$ on-axis for the mirror, with a matching size of the microcalorimeter pixels).

Objective 3.3. *Studies of the SNR structure* is the most demanding in terms of spectral resolving power in the hard X-ray band ($R \sim 2000$ at 6 keV) and the FOV and number of pixels in the X-ray microcalorimeter instrument (at least 5 arcmin FOV covered by 1 arcsec pixels).



SCIENCE OVERVIEW QUESTION 3

Present the highest-level technical requirements (e.g. spatial and spectral resolution, sensitivity, timing accuracy) and their relation to the science objectives.

- **Spatial resolution** is required to be 0.5 arcsec (HPD) on-axis, and maintained at a < 1 arcsec level across the 10arcmin-radius field of view. For relation to the science objectives, see above.
- The **sensitivity to point sources** in deep exposures is 1×10^{-19} erg/s/cm² in the 0.5-2 keV band. The primary driver is detection of black hole seeds during the Cosmic Dawn.
- The **spectral resolution for point sources** is $R > 5000$ in the 0.3-1 keV band, as needed to resolve the kinematic structure of galactic halos and access new plasma diagnostics for studies of stellar coronae.
- The **spectral resolution for diffuse sources** is $R > 2000$ in both the soft (0.3-0.9 keV) and hard (~ 6 keV) energy bands, as required for studies of galactic-scale energy feedback and physics of supernova remnants.
- The **sensitivity for point and diffuse sources**, as well as the need to obtain sufficient signal at the fine spectral resolution elements, dictates a mirror effective area of 2 m² at $E = 1$ keV.
- No science requires absolute timing accuracy to better than ~ 0.1 s. The Deep Space Network has the capability to provide absolute timing to the order of 100 microseconds. The HXDI instrument can read out small arrays in 100 microseconds and provide relative timing to that precision.

SCIENCE OVERVIEW QUESTION 4

For each performance requirement identified, describe as quantitatively as possible the sensitivity of the science objectives required to achieve the requirement. If you fail to meet a key requirement, what would be the impact be on achieving the science objectives?

For most of the key performance requirements, the inability to meet a particular requirement leads to a “soft failure” mode in a sense that *Lynx* is still able to achieve the science objectives but with a reduced efficiency:

- **Spatial resolution & sensitivity:** if the 0.5 arcsec (HPD) PSF on-axis and < 1 arcsec across the FOV is not achieved, that will primarily lead to a degradation in the achievable sensitivities in the deep surveys because of the source confusion. A significant impact on the sensitivity will be felt for HPD > 1.5 arcsec, when the estimated confusion limit is $\sim 4 \times 10^{-19}$ erg/s/cm², a factor of ~ 4 above the target for the deep surveys. The STDT has determined that with the HPD > 2 arcsec, the impact on *Lynx* science capabilities will be devastating ([Lynx Report, §9.2.1](#)).

Answer continued on next page

Response to **Science Overview** Question 4 (*continued*)

- The **sensitivity target for deep surveys**, 1×10^{-19} erg/s/cm², is softly defined because of uncertainties in the theoretical models of the massive black hole populations at $z=10$. A small reduction in the sensitivity will be tolerable. A significant impact will be felt for greater than a factor of ~ 4 reductions (see above). At that point, the capability to observe active star forming regions in the Milky Way will be also compromised ([Lynx Report](#), §3.1).
- An **inability to achieve the $R > 5000$ spectral resolution** with the XGS instrument will impact observations of galactic halos and detailed plasma diagnostics in the stellar coronae. Note, however, that some of these studies will still be possible (but with reduced science return) with the high-resolution array of the LXM instrument ($R = 2000$ in the soft X-ray band). The STDT-estimated impact from a complete loss of the XGS instrument is $\sim 16\%$ of the total *Lynx* science ([Lynx Report](#), §9.2, Table 9.3).
- If the $R = 2000$ spectral resolution is not achieved with the LXM, the impact on the *Lynx* science is also soft. The impact is insignificant for the 6 keV band until $R \sim 1000$. If $R = 2000$ is not achieved in the soft band, detailed kinematic mapping of the galactic outflows will not be possible, but the overall energetics of the outflows can still be measured with $R \sim 1000$ in the soft band.
- A **reduction in the mirror effective area** translates to longer exposures required to execute the same science. The impact of this change was quantified ([Lynx Report](#), §9.2, Table 9.3). *Lynx* science can tolerate moderate reductions in the effective area. No substantial cost savings are projected from reducing the mirror effective area. Instead, a possibility of meeting basic science requirements with a smaller mirror assembly should be viewed as an option to improve cost and schedule margin for manufacturing the LMA.

In summary, while *Lynx* science will be impacted by not meeting requirements, the actual performance within a factor of ~ 2 of the requirements would still permit significant progress in the science pillars and opening new discovery space.

* * *

TECHNOLOGY IMPLEMENTATION - INSTRUMENTATION
QUESTION 1

Describe the proposed science instrumentation, and briefly state the rationale for its selection. Discuss the specifics of each instrument (Inst #1, Inst #2 etc.) and how the instruments are used together.

We provide a summary response to this question below, but refer the reader to [Lynx Report](#), §5, pp.93-97, for the rationale for the instrument suite choice and main requirements, specifically:

[Lynx Report](#), §5, p.93 for the *Lynx* Mirror Assembly drivers,

[Lynx Report](#), §5, p.95 for the three science instruments: HDXI, XGS, and LXM, p. 95

[Lynx Report](#), Table 5.2 on p.97 for the traceability between the science requirements, the mirror assembly, and the science instruments.

[Lynx Report](#), §6.3, p.106-136 for the design of the telescope elements.

Answer continued on next page



Response to **Technology Implementation - Instrumentation** Question 1 (*continued*)

Below, we address the first part of this question, i.e. “Describe the proposed science instrumentation, and briefly state the rationale for its selection”.

The *Lynx* Observatory configuration is defined primarily by the science requirements for effective area, FOV, and angular and spectral resolution over a 0.2- to 10-keV energy range. To meet these requirements, *Lynx* has baselined its telescope to have a 3-m-diameter mirror assembly with a 10-m focal length, coupled to a suite of science instruments with a fixed optical bench structure. These three science instruments are known as the High-Definition X-ray Imager (HDXI), the X-ray Grating Spectrometer (XGS), and the *Lynx* X-ray Microcalorimeter (LXM).

The *Lynx* Mirror Assembly (LMA) ([Lynx Report, Executive Summary, pp. 8–9](#)): The LMA is the central element of the observatory. It is responsible for leaps in sensitivity, spectroscopic throughput, survey speed, and better imaging than *Chandra* because of much-improved off-axis performance. The Design Reference Mission (DRM) LMA technology is Silicon Metashell Optics (SMO) developed at NASA’s GSFC. The SMO’s highly modular design lends itself to parallelized manufacturing and assembly, while also providing high fault tolerance: if some individual mirror segments or even modules are damaged, the impact to schedule and cost is minimal.

The High Definition X-ray Imager (HDXI) ([Lynx Report, Executive Summary, p. 10](#)): The HDXI instrument is the main imager for *Lynx*, providing high spatial resolution over a wide FOV and good sensitivity over the 0.2–10 keV bandpass. Its 0.3” pixels will adequately sample the *Lynx* mirror PSF over a 22’ × 22’ FOV. The 21 individual sensors are laid out along the optimal focal surface to improve the off-axis PSF. The *Lynx* DRM uses Complementary Metal Oxide Semiconductor (CMOS) Active Pixel Sensor (APS) technology, which is projected to have the required capabilities (i.e., high readout rates, high broad-band quantum-efficiency, sufficient energy resolution, minimal pixel crosstalk, and radiation hardness).

The *Lynx* X-ray Microcalorimeter (LXM) ([Lynx Report, Executive Summary, pp. 10–11](#)): The LXM will provide non-dispersive spectroscopy, required by many science programs. The LXM is an imaging spectrometer that provides high resolving power ($R \sim 2,000$) in both the hard and soft X-ray bands, combined with high spatial resolution (down to 0.5” scales). To meet the diverse range of *Lynx* science requirements, the LXM focal plane includes three arrays that share the same readout technology. Each array is differentiated by its absorber pixel size and thickness, and by how the absorbers are connected to thermal readouts.

The X-ray Grating Spectrometer (XGS) ([Lynx Report, Executive Summary, pp. 11–12](#)): A higher resolution than what can be provided by X-ray microcalorimeters is required for absorption-line studies of diffuse use baryons in galactic halos, physics of stellar coronae, and assessing the impact of stellar activity on habitability of their planets. This capability will be provided by the XGS ($R = 5,000$ with a goal of 7,500) in the soft X-ray band for point sources. Compared to the current state of the art (*Chandra*), the XGS provides a factor of > 5 higher spectral resolution and a factor of several hundred higher throughput. These gains are enabled by recent advances in X-ray grating technologies.

Answer continued on next page

Response to **Technology Implementation - Instrumentation** Question 1 (*continued*)

We now address the second part of this question, i.e. “*Discuss the specifics of each instrument (Inst #1, Inst #2 etc.)*”. For this part of our answer, we refer the reader to the below sections of the *Lynx* report for more detail:

- Enabling Technology #1, Lynx Mirror Assembly:** [Lynx Report](#), §6.3.1, pp. 107–113
- Enabling Technology #2, High Definition X-ray Imager:** [Lynx Report](#), §6.3.2, pp. 113–118
- Enabling Technology #3, X-ray Grating Spectrometer:** [Lynx Report](#), §6.3.3, pp. 118–124
- Enabling Technology #4, Lynx X-ray Microcalorimeter:** [Lynx Report](#), §6.3.4, pp. 124–133

These sections provide a concise overview of the 4 enabling technologies for *Lynx* and critical performance considerations for each (e.g., contamination control, thermal considerations, and survivability). Detailed overviews are also provided in:

1. The [Technology Roadmaps](#)
2. Design studies that are not included in the report. These studies were developed through Instrument Design Labs at NASA GSFC and Instrument Design Studies at NASA MSFC, and are available upon request.
3. Many papers published in the *Lynx* Special Section of the *Journal of Astronomical Telescopes, Instruments, and Systems* (JATIS), available at <https://wwwastro.msfc.nasa.gov/lynx/docs/documents/Technology/>

Finally, we answer the last part of this question, i.e. “*...and how the instruments are used together*”.

[Lynx Report](#), §6.3.5 (pp. 133–134) describes the Integrated Science Instrument Module (ISIM). The ISIM is the support structure for the focal plane instruments that interfaces to the Optical Bench Assembly (OBA) and places the required focal plane camera in the proper position for each observation. The HDXI and LXM are mounted on a translating table, while the XGS detector assembly is mounted on a fixed platform on the ISIM. The XGS grating array is mounted just behind the mirror assembly and can be deployed into and out of the optical path as required.

[Lynx Report](#), §6.3.5 (pp. 170–173) describes the operating modes for the *Lynx* science instruments and provides an example science observing scenario. The instruments operate independently, each can be chosen for a particular science observation, and XGS can be used in concert with either HDXI or LXM. One example is found on p. 171: “When the XGA is inserted, the XGS-dispersed spectrum is directed onto the XGD, while the non-dispersed portion can be focused onto either focal plane instrument. Therefore, there are four observing configurations available for science observations:

1. XGS gratings inserted and LXM at the primary focus (XGS+LXM)
2. XGS gratings inserted and HDXI at the primary focus (XGS+HDXI)
3. HDXI as the primary with gratings retracted (HDXI only)
4. LXM as the primary focal plane instrument with gratings retracted (LXM only)”

In addition to these configurations, LXM has three arrays, each with a different combination of imaging resolution, energy resolution, and Field-of-View (FOV). An individual array on the LXM can be selected as needed by a particular science observation by moving the ISIM translation table.



TECHNOLOGY IMPLEMENTATION - INSTRUMENTATION
QUESTION 2

Indicate the technical maturity level of the major elements and the specific instrument TRL of the proposed instrumentation (for each specific Inst #1, Inst #2 etc.), along with the rationale for the assessment (i.e. examples of flight heritage, existence of breadboards, prototypes, mass and power comparisons to existing units, etc.). For any instrument rated at a Technology Readiness Level (TRL) of 5 or less, please describe the rationale for the TRL rating, including the description of analysis or hardware development activities to date, and its associated technology maturation plan.

We first address the initial part of this question, i.e. “Indicate the technical maturity level of the major elements and the specific instrument TRL of the proposed instrumentation (for each specific Inst #1, Inst #2 etc.)”. For this part of our answer, we refer the reader to [Lynx Report, §7, pp. 182–214, and Table 7.1 on p.184](#) providing a summary of TRL Milestones.

The Technology Readiness Levels of our four enabling technologies are currently as follows:

Table 1. Technology Readiness Levels (TRLs) of the four Lynx Enabling Technologies

Enabling Technology #	Name	Current TRL
1	Lynx Mirror Assembly: Silicon Metashell Optics	3
2	High Definition X-ray Imager (HDXI)	3
3	X-ray Grating Spectrometer (XGS)	4
4	Lynx X-ray Microcalorimeter (LXM)	3

It is important to note that even though three of the technologies are at a TRL 3, they all have many elements that are approaching or are already more mature (TRL 4 or higher). The ability and timeframe for each technology to reach the next TRL by instrument sub-element are detailed in the supplemental [Technology Roadmaps](#). One example of this is with the LXM (see, e.g., [Table 1 of LXM Technology Roadmap](#)). We reproduce this table as **Table 2** below:

Answer continued on next page

Response to **Technology Implementation - Instrumentation** Question 2 (*continued*)**Table 2.** *Lynx* X-ray Microcalorimeter (LXM) Technology Elements

Element #	LXM Element Description	Current TRL	Note
1	Large format, high spectral resolution microcalorimeter pixel arrays	3	Should reach TRL 4 in CY19 or early CY20
2	Microcalorimeter readout	3	Should reach TRL 4 in CY19 or early CY20
3	Focal plane assembly and filters	4	
4	Cryogenics	4	

We now address the second part of this question, i.e. “...along with the rationale for the assessment (i.e. examples of flight heritage, existence of breadboards, prototypes, mass and power comparisons to existing units, etc.). For any instrument rated at a Technology Readiness Level (TRL) of 5 or less, please describe the rationale for the TRL rating, including the description of analysis or hardware development activities to date, and its associated technology maturation plan.” For this part of our answer, we refer the reader to the following sections of the *Lynx* Report:

Enabling Technology #1, Silicon Meta-Shell Optics: [Lynx Report](#), §7.2.1, pp. 187–196

Enabling Technology #2, High Definition X-ray Imager: [Lynx Report](#), §7.3.1, pp. 197–200

Enabling Technology #3, Critical-Angle Transition XGS: [Lynx Report](#), §7.3.2, pp. 201–206

Enabling Technology #4, *Lynx* X-ray Microcalorimeter: [Lynx Report](#), §7.3.4, pp. 206–214

These sections of the report summarize, at a high-level, the current TRLs for the *Lynx* DRM enabling technologies. The current TRLs for feasible alternate technologies for each enabling technology are also provided in the report.

A much more detailed summary of the current TRL and rationale for each technology is included in the [Technology Roadmaps](#). These plans include an overview of the technology, a description of the current state-of-the-art, key milestones specific to that particular technology (and system), their Advancement Degree of Difficulty (AD2) between TRLs, milestone details with significance and verification, schedule for maturation, cost, and top risks related to the maturation.

**TECHNOLOGY IMPLEMENTATION - INSTRUMENTATION
QUESTION 3**

In the area of instrumentation, what are the top five technical issues or risks?

Below, we list five top risks, one for each enabling technology and a project risk related to the *Lynx* mirror manufacturing.

Enabling Technology #1, Silicon Meta-Shell Optics: [Lynx Report](#), §7.2.1.1, p. 194, paragraph 2:

There remains a risk that epoxy shrinkage during cure may cause larger-than-expected figure distortion within the segment “stack” comprising a mirror module. If this risk materializes, the number of mirror segments bonded to a module may need to be reduced, therefore increasing the number of modules needed. This will effectively reduce strength requirements and enable the use of much smaller amounts of epoxy, leading to less distortion. The net consequence of this is a slight reduction in the effective area of the LMA, as more modules will lead to a slightly lower nesting efficiency.

Enabling Technology #2, High Definition X-ray Imager: [Lynx Report](#), §7.3.1, p. 200, paragraph 3

The risks and challenges to advancing the HDXI technology to TRL 4 are primarily attributable to budget and schedule if all the HDXI requirements cannot be demonstrated on a single architecture over the course of the TRL 4 development process. Funding three sensor technologies in the early stages of the *Lynx* mission is a risk mitigation approach that warrants a high degree of confidence for success based on past experience. A final downselect to a single architecture is planned at the start of Phase A following demonstration of TRL 4 performance.

Enabling Technology #3, Critical-Angle Transition XGS: [Lynx Report](#), §7.3.2, p. 205, paragraph 1

Identified risks are primarily matters of production and manufacturing scale and can be mitigated by design conservatism.

Enabling Technology #4, Lynx X-ray Microcalorimeter: see [Lynx Report](#), §7.3.4, pp. 206–214

As presented in detail in the [LXM Technology Roadmap](#), alternative technologies are being independently funded and investigated for the thermal sensor, readout electronics, and cryocooler elements of the *Lynx* design. This approach helps to mitigate about one-third of the identifiable technical and schedule risks while simultaneously enhancing the potential for bringing new and innovative technological solutions to the program. Formal selection of baseline LXM technologies for these elements will be made soon after TRL 5 performance has been verified (i.e., near the start of Phase A).

A detailed summary of the top 5 risks related to technology maturation for each of the technologies and their mitigation are detailed in the [Technology Roadmaps](#).

Answer continued on next page

Response to **Technology Implementation - Instrumentation** Question 3 (*continued*)

Lynx Project Risks: [Lynx Report](#), §8.3, pp. 218–223

Lynx Project Risks include: X-ray mirror module assembly and alignment, LXM technical maturation to TRL 6, X-ray mirror segment industrialization, LXM fabrication and assembly, X-ray mirror technical maturation to TRL 6, and HDXI/XGD technology maturation to TRL 6. Likelihoods and Consequences are provided for each, and mitigation plans are described as well as the impact to the project.

**TECHNOLOGY IMPLEMENTATION - INSTRUMENTATION
QUESTION 4**

Fill in entries in the Instrument Table. Provide a separate table for each Instrument (Inst #1, Inst #2 etc.). As an example, a telescope could have four instruments that comprise a payload: a telescope assembly, a NIR instrument, a spectrometer and a visible instrument each having their own focal plane arrays. Please identify the basis for the CBE (Current Best Estimate).

We first provide some comments on the below Instrument Tables:

1. Current Best Estimate values are based on detailed design studies for each of the enabling technologies. Results from these studies are summarized in the [Lynx Report](#). Additional design details can be provided if requested.
2. In all cases contingency is presented as an average mass growth allowance (MGA) for individual instrument subsystem elements, based on their maturity and according to AIAA MGA standards.
3. Data rates are conservatively set for each instrument and are easily accommodated with the high-heritage *Lynx* Command and Data Handling (C&DH) system with margin. *Lynx* C&DH is described in [Lynx Report](#), §6.4.2, p. 146.
4. Pointing requirements are set by the Guidance, Navigation, and Control (GN&C) for the observatory, described in [Lynx Report](#), §6.4.2, pp. 139–141 and Table 6.15. These requirements are similar to those of *Chandra* and are met with low-risk design solutions.

Answer continued on next page

Response to **Technology Implementation - Instrumentation** Question 3 (*continued*)**Table 3.** *Lynx* Pointing Requirements

Pointing Requirements	Requirement	Units / Note
Onboard	4	arcsec
Ground Aspect (absolute to sky)	1*	arcsec rms radius
Absolute pointing accuracy	10	arcsec (3 σ) radius
Stability	± 0.17	arcsec / sec <i>Note that this is a jitter requirement in any one-second time interval. Over longer periods of time, slower random walk anywhere within the required 10 arcsec absolute pointing accuracy is allowed.</i>

* Note that Chandra provides 0.6 arcsec rms absolute pointing and a still better positional accuracy for sources after boresight correction. After boresight correction, *Lynx* is expected to achieve source positioning to <0.15 arcsec rms in a typical imaging exposure.

Answer continued on next page



Response to **Technology Implementation - Instrumentation** Question 3 (*continued*)

Instrument Table: The Lynx Mirror Assembly (LMA)

For more details concerning this table, see [Lynx Report, §6.3.1](#) and specifically:
[§6.3.1.1 for the LMA Design Overview](#)
[Table 6.3 on p. 108 for the LMA Requirements](#)
[Table 6.4 on p. 110 for the LMA Design Characteristics](#)

The *Lynx* Mirror Assembly (LMA) is not a science instrument, but is critical to meeting *Lynx* science requirements. The design parameters are summarized in the table listed below. The LMA is a fixed structure mounted to the Optical bench via bipods, and it requires both passive and active thermal control.

Table 4. “Instrument” Table | *Lynx* Mirror Assembly (LMA)

Item	Value	Units
Type of Instrument	<i>Lynx</i> Mirror Assembly	
Size / Dimensions	3 × 0.85	m × m
Instrument mass without contingency (CBE*)	1,881.5	kg
Instrument Mass Contingency	25	%
Instrument mass with contingency (CBE + Reserve)	2,351.9	kg
Instrument average payload power without contingency (dominated by Mirror Heater)	1,191	W
Instrument average payload power contingency	13	%
Instrument average payload power with contingency (dominated by Mirror Heater)	1,345.8	W
Instrument average science data [†] rate without contingency	only a small amount of housekeeping data	
Instrument Field(s) of View (if appropriate)	20 (<i>diameter</i>)	arcminutes

* CBE = Current Best Estimate. Mass includes mirror modules, thermal control, contamination door assemblies, and the LMA barrel assembly. The MGA and power contingencies are determined for individual instrument subsystem elements, based on their maturity and according to AIAA standards.

Answer continued on next page

Response to **Technology Implementation - Instrumentation** Question 3 (*continued*)**Instrument Table: The High Definition X-ray Imager (HDXI)**

For more details concerning this table, see see [Lynx Report](#), §6.3.2 and specifically:

[§6.3.2.1 for the HDXI Design Overview](#)

[Table 6.6 on p. 114 for the HDXI Requirements](#)

[Table 6.7 on p. 117 for the HDXI Design Characteristics](#)

The only mechanism for the HDXI is a filter assembly. This instrument is located on a translation/focus table on the Integrated Science Instrument Module along with the *Lynx* X-ray Microcalorimeter.

Table 5. Instrument Table | High Definition X-ray Imager Microcalorimeter (HDXI)

Item	Value	Units
Type of Instrument	Imaging detector array with spectroscopic capability	
Number of Channels	1024 × 1024	21 sensors
Size / Dimensions	0.48 × 0.48 × 0.36	m × m × m
Instrument mass without contingency (CBE*)	80.4	kg
Instrument Mass Contingency	30	%
Instrument mass with contingency (CBE + Reserve)	104	kg
Instrument average payload power without contingency - Science Mode	178	W
Instrument average payload power contingency	40	%
Instrument average payload power with contingency - Science Mode	249	W
Instrument average science data [†] rate without contingency	600	kbps
Instrument peak data rate	6	Mbps
Instrument average science data [†] rate contingency	N/A	N/A
Instrument average science data [†] rate with contingency	600	kbps
Instrument Field(s) of View (if appropriate)	22 (<i>diameter</i>)	arcminutes

* CBE = Current Best Estimate

† Instrument data rate defined as science data rate prior to on-board processing

The MGA and power contingencies are determined for individual instrument subsystem elements, based on their maturity and according to AIAA standards.

Response to **Technology Implementation - Instrumentation** Question 3 (*continued*)**Instrument Table: X-ray Grating Spectrometer (XGS) Detector Assembly**

For more details concerning this table, see [Lynx Report, §6.3.3](#) and specifically:

[§6.3.3.1 for the XGS Design Overview](#)

[Table 6.8 on p. 119 for the CAT-XGS Requirements](#)

[Table 6.9 on p. 121 for the CAT-XGS Design Characteristics](#)

[Table 6.10 on p. 123 for the CAT-XGS Detector Array](#)

The *Lynx* X-ray Grating Spectrometer (XGS) instrument has two primary elements. One element is the grating array, which is located just aft of the *Lynx* Mirror Assembly. The second element is the detector array located on a fixed platform on the Integrated Science Instrument Module. The XGS Table below provides requested data for the XGS detector array. The XGS sensors are the same as those for HDXI, such that development costs and batch fabrication and test can be performed, potentially saving on cost.

Table 6. Instrument Table | X-ray Grating Spectrometer (XGS) Detector Assembly

Item	Value	Units
Type of Instrument	Dispersive spectrometer	
Number of Channels	1,024 × 1,024	18 sensors
Size / Dimensions	0.4 × 0.3 × 0.15	m × m × m
Instrument mass without contingency (CBE)	65	kg
Instrument Mass Contingency	24	%
Instrument mass with contingency (CBE + Reserve)	80.4	kg
Instrument average payload power without contingency - Science Mode	136	W
Instrument average payload power contingency	40	%
Instrument average payload power with contingency - Science Mode	190	W
Instrument average science data rate without contingency	600	kbps
Instrument peak data rate	6	Mbps
Instrument average science data rate contingency	N/A	N/A
Instrument average science data rate with contingency	600	kbps
Instrument Field(s) of View (if appropriate)	N/A	N/A

The MGA and power contingencies are determined for individual instrument subsystem elements, based on their maturity and according to AIAA standards.



Response to **Technology Implementation - Instrumentation** Question 3 (*continued*)

Instrument Table: The Lynx X-ray Microcalorimeter

For more details concerning this table, see [Lynx Report, §6.3.4](#) and specifically:

[§6.3.4.1 for the LXM Design Overview](#)

[Table 6.11 on p. 128 for the LXM Requirements](#)

[Table 6.12 on p. 130 for the LXM Design Characteristics](#)

The *Lynx* X-ray Microcalorimeter (LXM) has 3 readout arrays that share a common readout structure. Each array is designed to meet particular *Lynx* science requirements. The Main Array (MA) is designed to provide a large FOV with good angular resolution and energy resolution across the *Lynx* bandpass. The Enhanced Main Array (EMA) has a narrower FOV, but an angular resolution that is precisely matched to that of the *Lynx* telescope. The Ultra-High-Resolution Array (UHRA) has the same reduced FOV as the EMA, but with much higher energy resolution at lower energies, achieved with thinner absorbers

Table 7. Instrument Table | *Lynx* X-ray Microcalorimeter (LXM)

Item	Value	Units
Type of Instrument	Imaging spectrometer	
Number of Channels	7,632	TES readouts
Size / Dimensions	2.7 × 0.6	m × m
Instrument mass without contingency (CBE)	468	kg
Instrument Mass Contingency	25	%
Instrument mass with contingency (CBE + Reserve)	585	kg
Instrument average payload power without contingency - Science Mode	1,575	W
Instrument average payload power contingency	40	%
Instrument average payload power with contingency - Science Mode	2,205	W
Instrument average science data rate without contingency	20	kbps
Instrument peak data rate	8	Mbps
Instrument average science data rate contingency	N/A	N/A
Instrument average science data rate with contingency	20	kbps
Instrument Field(s) of View (if appropriate)		
Main Array	5 × 5	arcminutes
Enhanced Main Array	1 × 1	
Ultra-High Resolution Array	1 × 1	

**TECHNOLOGY IMPLEMENTATION - INSTRUMENTATION
QUESTION 5**

If you have allocated contingency please describe it,
along with the rationale for the number chosen.

Mass Growth Allowance (MGA) and Power contingency have been applied to all systems. A flat-MGA percentage was not applied to all subsystems, rather the MGA was determined for individual subsystem elements based on AIAA guidelines, the values of which varies as a function of hardware type (e.g., electrical components, structure, thermal control, propulsion, mechanisms, etc..) and maturity. Power margin of 40% was used in all cases except for the mirror heaters, where it is 13%, based on very high design heritage of this thermal control component. The MGA and Power margin are included in the [MEL+PEL supplements](#).

Contingency on individual instrument data rates is not provided. However, data rates are conservatively set for each instrument and are easily accommodated with the high-heritage *Lynx* Command and Data Handling (C&DH) system with margin, as described in [Lynx Report](#), §6.4.6, p.146

**TECHNOLOGY IMPLEMENTATION - INSTRUMENTATION
QUESTION 6**

If known, provide a description of what organization is responsible for each
instrument and summarize relevant past experience with similar instruments.

Enabling Technology #1: **Lynx Mirror Assembly** – [Lynx Report](#), p.188, paragraph 2
Silicon Meta-Shell Optics LMA (DRM): NASA GSFC
Full Shell Optics: NASA MSFC, INAF Brera
Adjustable Optics: SAO/PSU

Enabling Technology #2: **High Definition X-ray Imager** – [Lynx Report](#), p.198, Fig. 7.6
Hybrid CMOS HDXI (DRM): Teledyne/PSU
Monolithic CMOS HDXI: SRI/SAO
Digital CCD with CMOS HDXI: MIT/Lincoln Laboratory

Enabling Technology #3: **X-ray Grating Spectrometer** – [Lynx Report](#), p.202 (paragraph 1) and p.205 (paragraph 3)
Critical Angle Transmission-XGS (DRM): MIT
Off-Plane-XGS: PSU

Enabling Technology #4: **Lynx X-ray Microcalorimeter** – [Lynx Report](#), p.207 (paragraph 1)
LXM (DRM): NASA GSFC

Once *Lynx* becomes a Project, all enabling technologies will be competed. Each of the enabling technologies (and some of the subsystem elements) has multiple feasible alternates. The Design Reference Mission (DRM) - defined enabling technologies are all being developed by U.S. institutions, each with a long history of related development. In many cases, the developing institutions have experience developing similar instruments with flight heritage from which the *Lynx* technologies have evolved. Alternate feasible technologies developing institutions are also provided. A technology maturation plan for the DRM and feasible alternates is available in [Technology Roadmaps](#). These plans were developed by the institutions listed above.

**TECHNOLOGY IMPLEMENTATION - INSTRUMENTATION
QUESTION 7**

For the science instrumentation, describe any concept, feasibility, or definition studies already performed.

High-level details from design and feasibility studies for the *Lynx* enabling technologies are included in [Lynx Report, §6](#). Detailed results from these studies can be provided as requested.

All of the *Lynx* enabling technologies underwent one or more design and feasibility studies. These studies were done primarily through the NASA GSFC Instrument Design Lab and the NASA MSFC Advanced Concept Office, with support from the *Lynx* Study Office and the principal researchers/Subject Matter Experts. Once these studies were carried out, updates were made to refine the designs and feasibility, and to reflect recent progress and achievements. The integrated system was also taken into account. Details can be found in [Lynx Report, §6.6, p.150](#).

Enabling Technology #1: Lynx Mirror Assembly Silicon Meta-Shell Optics — Design and feasibility studies were carried out at NASA GSFC with support from NASA MSFC and SAO for additional analyses. LMA manufacturing studies were done with the support of Northrop Grumman and Harris and involved NASA GSFC optics researchers.

Enabling Technology #2: High Definition X-ray Imager — An Instrument Design Lab at NASA GSFC and an Instrument Design Study at NASA MSFC were performed

Enabling Technology #3: X-ray Grating Spectrometer — An Instrument Design Study was carried out at NASA MSFC, with refinements to the design and ray-tracing provided by MIT

Enabling Technology #4: Lynx X-ray Microcalorimeter — An LXM Instrument Design Lab was carried out at NASA GSFC. Updates were made to this initial study at both NASA MSFC (in terms of system integration) and GSFC (instrument refinement).

**TECHNOLOGY IMPLEMENTATION - INSTRUMENTATION
QUESTION 8**

For instrument operations, provide a functional description of operational modes, and ground and on-orbit calibration schemes. Describe the level of complexity associated with analyzing the data to achieve the scientific objectives of the investigation. Describe the types of data (e.g. bits, images) and provide an estimate of the total data volume returned.

We first address the initial part of this question, i.e. “*For instrument operations, provide a functional description of operational modes...*”. Here, we refer the reader to [Lynx Report, §6.7.2, pp.170–172](#).

On-orbit operational modes can be classified as “Normal Pointing Mode” or “Maneuver Mode” with an additional “Safe Mode.” ToOs are carried out using the Normal Pointing and Maneuver modes.

Answer continued on next page



Response to **Technology Implementation - Instrumentation** Question 8 (*continued*)

Therefore, there are four observing configurations available for science observations in Normal Pointing Mode:

1. XGS gratings inserted and LXM at the primary focus (XGS+LXM)
2. XGS gratings inserted and HDXI at the primary focus (XGS+HDXI)
3. HDXI as the primary with gratings retracted (HDXI only)
4. LXM as the primary focal plane instrument with gratings retracted (LXM only)

In addition to these configurations, LXM has three arrays, each with a different combination of imaging resolution, energy resolution, and Field-of-View (FOV). An individual array on the LXM can be selected as needed by a particular science observation.

We now address the second part of this question, i.e. “...and ground and on-orbit calibration schemes”. Here, we refer the reader to [Lynx Report, §6.6.3.1, pp.161–163](#).

After performing an assessment of available X-ray calibration facilities, the *Lynx* team decided to baseline the use of MSFC’s X-ray and Cryogenic Facility (XRCF) for on-ground calibration verification activities of the LMA and scientific instruments. This facility was built in the 1990s for the *Chandra* project, is being considered for use by ESA’s *Athena* project, and can accommodate the *Lynx* on-ground calibration campaign.

Prior to testing and calibration verification in the XRCF, the individual LMA mirror modules will be calibrated prior to integration into the full LMA assembly. The HDXI and XGS individual detectors and detector array will be tested at the developers facilities. An LXM engineering model will undergo extensive qualification testing beyond the typical level of an EDU in order to space-qualify the design. The engineering model, not the flight unit, will be X-ray tested along with the LMA TRL demonstrator ([Lynx Report, §7.2.1](#)) at the XRCF. This plan for LXM is consistent with that for the Resolve microcalorimeter on XARM and for the planned *Athena* X-IFU instrument.

As described in [Lynx Report \(§6.7.3, p.174\)](#), a set of standard celestial targets will be determined for on-orbit calibration use. These targets will be periodically observed to monitor the LMA, all science instruments, and aspect system performance. Calibration observations are planned, scheduled, and executed as part of Normal Pointing Mode operations (accompanied by Maneuver Mode slews) (see [Lynx Report, §6.7.2](#)).

We now address the third part of this question, i.e. “Describe the level of complexity associated with analyzing the data to achieve the scientific objectives of the investigation”. Here, we refer the reader to [Lynx Report, §6.7.4, p.174–176](#).

The level of complexity is similar to that of the *Chandra* X-ray Observatory. There exists a proven process for analyzing this data. Telemetry data are decommutated (level 0 processing), then the aspect solution is performed and the time, energy, and a quality flag are tagged to each photon (level 1 processing). In standard level 2 processing, higher quality selections of detected X-ray photons are applied (e.g., to eliminate most of the instrumental background events). The level 1 and level 2 results go through an automated V&V process. All products are archived and made available to the observer. The tools for science analysis and the calibration products (including, e.g., the mirror PSF, detector QE and energy resolution, gratings spectral resolution, instrumental backgrounds) are developed and distributed to the *Lynx* users. Reprocessing of



Response to **Technology Implementation - Instrumentation** Question 8 (*continued*)

Lynx data is possible at the user's desktop computer. *Lynx* users will be able to use a rich collection of science methods, algorithms, and analysis tools developed for *Chandra*. A higher statistical quality of *Lynx* data will also allow them to tap into a large body of general-purpose astronomical software, e.g. the tools developed for the analysis of optical IFU data.

We now address the fourth part of this question, i.e. “Describe the types of data (e.g. bits, images) and provide an estimate of the total data volume returned.” Here, we refer the reader to [Lynx Report](#), §6.4.6, p.146 and Table 6.19.

Data that is sent to the ground is related to the properties of each detected photon (primarily energy and position). *Lynx* is not required to send images, which can be taxing on the telemetry. The science data dominates the data volume, but is still reasonable at 240 Gbits/day, at a rate of 2.78 Mbps.

TECHNOLOGY IMPLEMENTATION - INSTRUMENTATION
QUESTION 9

Describe the level of complexity of the instrument flight software.

Primary reference: [Lynx Report](#), §6.4.5, p.143–145 (Avionics and Flight Software) and §6.7.2, p.171, paragraph 4 (On-Orbit Operations and Normal Pointing Mode).

The Nominal Pointing Mode is transparent to the selection or internal settings of the focal plane instruments. The *Lynx* data subsystem interfaces with each camera to collect CCSDS-standard encoded packets of data as they are assembled by the camera software. Data collection and time registration are synchronized by signals from the precision spacecraft clock. The data packets contain X-ray events, background events that mimic X-rays, and auxiliary configuration, timing, temperature, voltage, and current “housekeeping” data from the instrument.

The level of complexity of the instrument flight software can be estimated by scaling from previously flown missions with similar instruments.

HDXI & XGD — The *Lynx* HDXI and XGS Detector array (XGD) will use the same sensors such that the development and fabrication costs can be reduced. The HDXI array has 21 sensors (each with 1024×1024 pixels), while the XGD array has 18 sensors. The functional requirements for the flight software are essentially identical to those of the software flown on legacy missions such *Chandra*/ACIS and XMM/EPIC. The former instrument contains about 20,000 lines of flight code. A *Lynx* Study Team Subject Matter Expert (SME) with ACIS experience estimated that a modern implementation of the HDXI flight software would likely require less than 50,000 lines of code. The much higher pixel- and event-rates produced by HDXI will readily be accommodated by using modern hardware. For example, pixel processing (event finding) will be done in firmware (firmware for doing so is already demonstrated at TRL5) and larger 30–100× event rates (relative to *Chandra*) can be accommodated by currently available processors.

Answer continued on next page

Response to **Technology Implementation - Instrumentation** Question 9 (*continued*)

LXM Flight Software — The functional requirements for the LXM flight software are similar to those of preceding instruments such as *Hitomi* SXS, *XRISM* Resolve, and *Athena* X-IFU. The LXM software is slightly more complicated based on the increase in pixel count, but still, the main function of the software is to take low-rate data interfaced from the FPGA and interface to the data recorder of the spacecraft. In-flight pixel calibration can be performed on the ground or on board. In the case of on-board re-calibration, the most intensive computation would be polynomial fitting to data sets typically with less than 100 values. These calculations will not be done in real-time and therefore there will be no strong requirement on speed, and the complexity will remain low.

**TECHNOLOGY IMPLEMENTATION - INSTRUMENTATION
QUESTION 10**

Describe any instrumentation or science implementation that requires non-US participation for mission success.

None at this time.

**TECHNOLOGY IMPLEMENTATION - INSTRUMENTATION
QUESTION 11**

Please provide a Master Equipment List (MEL) for the payload sub-categorized by each specific instrument indicating mass and power of each component at the level of specificity known.

The MEL spreadsheet is included as an attachment to this RFI. There are multiple tabs in the MEL. These tabs include a roll-up, as well as individual instruments broken out. A Power Schedule describing power per component per duty cycle of each operational mode is also included.

**TECHNOLOGY IMPLEMENTATION - INSTRUMENTATION
QUESTION 12**

Describe the flight heritage of the instruments and their subsystems. Indicate items that are to be developed, as well as any existing hardware or design/flight heritage.

Discuss the steps needed for space qualification. Describe any required deployments.

Addressing the first part of this question, i.e. “Describe the flight heritage of the instruments and their subsystems. Indicate items that are to be developed, as well as any existing hardware or design/flight heritage. Discuss the steps needed for space qualification”:

The State-of-the-Art, existing hardware developments, and steps needed to reach TRL 6 for each *Lynx* enabling technology are described in detail in the [Technology Roadmaps](#).

Even though the exact optics and science instruments required for *Lynx* have not flown on previous missions, elements of each enabling technology will apply lessons learned from previous flight developments that the instrument subject matter experts have been involved in. All of the instruments are natural evolutions of instruments that have previously flown or are being developed for flight

Enabling Technology #1, Silicon Meta-Shell Optics: [Lynx Report](#), §7.2.1, pp. 187–194

Even though these optics are a very different form factor than the *Chandra* mirrors and necessitate a different manufacturing and assembly - this technology combines the direct fabrication grind-and-polish method (proven for *Chandra*'s sub-arcsecond optical performance) with mature production technologies widely used in the semiconductor industry, such as ion beam figuring and CNC machining. Critically, the technology uses a nearly ideal substrate (monocrystalline silicon) to fabricate extremely thin optical components.

Enabling Technology #1, Silicon Meta-Shell Optics: [Lynx Report](#), §6.3.2.1, p. 114, paragraph 1

Silicon-based X-ray imaging spectrometers are standard for nearly every recent X-ray observatory. Examples include *Chandra*'s ACIS, *XMM-Newton*'s EPIC MOS and PN Cameras, and *Suzaku*'s X-ray Imaging Spectrometer (XIS). All of these instruments use traditional X-ray CCDs with acceptable spectroscopic performance and imaging capability but relatively low readout rates. For X-ray observations with next-generation telescopes such as *Lynx* and *Athena*, the current generation of pixelated silicon sensors offer high readout rates, high-broadband quantum efficiencies, and minimal crosstalk compared to traditional CCDs, and have thus been baselined for the *Lynx* DRM.

Enabling Technology #3, X-ray Grating Spectrometer: [Lynx Report](#), §6.3.3.1, p. 120, paragraph 2

The XGS design is based on the *Chandra* HETG spectrometer, which is a Rowland torus design but optimized for blazed transmission gratings (i.e., “tilted Rowland torus”).

Answer continued on next page

Response to **Technology Implementation - Instrumentation** Question 12 (*continued*)**Enabling Technology #4, Lynx X-ray Microcalorimeter:** [Lynx Report](#), §6.3.4.1, p. 131, paragraph 3

The LXM design is a natural progression from *Hitomi*'s SXS, the X-ray Imaging and Spectroscopy Mission's (*XRISM*'s) Resolve, and *Athena*'s X-IFU. One example of how *Lynx* will leverage technology development from these other payload is through the use of the Modulated X-ray Source (MXS), which will be included on the LXM FPA for in-flight calibration by providing pulsed X-ray lines at multiple energies. The LXM will also leverage the X-IFU readout layout (similar wire density and flex cable technologies) due to the similar focal plane size. This also allows for the mechanical, thermal, magnetic shielding, anticoincidence detector, and IR filter designs from the X-IFU to be leveraged. Cooling the LXM focal plane will be met with a cryostat that uses heritage from SXS and Resolve, and design details from the X-IFU. Other cooling system elements will be achieved via a thrust-tube-type design mounted in a fashion similar to that used for Spitzer.

We now address the second part of this question, i.e. “Describe any required deployments”:

The Integrated Science Instrument Module (ISIM) provides an interface to the Optical Bench Assembly and houses the focal plane instruments (HDXI, the X-ray Grating Detector (XGD) assembly, and LXM), their electronics, radiators, and supporting structure ([Lynx Report](#), Fig. 6.6). Two of the science instruments—HDXI and LXM—along with their electronics and radiators are mounted on a moveable platform that is part of the ISIM, while the XGD assembly is located on a fixed platform. ([Lynx Report](#), §6.3.5, pp. 133–134, Table 6.13, and §6.3, p.107).

To control contamination, doors have been incorporated into the LMA that allow for a dry nitrogen purge on the ground, with the covers remaining closed post-calibration through the completion of a post-launch outgassing phase ([Lynx Report](#), §6.3.2.1, p. 111). The aft contamination door is also shown in [Lynx Report](#), Fig. 6.5, p.106.

The filter mechanism for the HDXI instrument is a unique design capable of supporting multiple filters that can be used in combination with one another. Though the DRM design includes an open aperture, an optical blocking filter, a 55Fe calibration source, and a closed position, additional filter types will be studied during Phase A to maximize the science value ([Lynx Report](#), §6.3.2.1, p. 117)

The single retractable grating array is attached to the LMA structure ([Lynx Report](#), Fig. 6.16). Effort has been made to keep the mechanism simple while maintaining precise positioning each time the gratings are deployed. The actuator used to deploy the grating array allows for 1.2- μm -level positioning for high repeatability. A second actuator has been added for redundancy. CAT gratings have an alignment tolerance of roughly 100–200 μm along the optical axis, well within the capability of these actuators. ([Lynx Report](#), §6.3.3.1, p. 121)

The XGS detector array does not have a filter wheel, but does have a built-in focus mechanism and a vacuum enclosure door that will be opened on-orbit. ([Lynx Report](#), §6.3.3.1, pp. 122–123 and Fig 6.18)

Outside of the gate valve, the LXM will include an external filter wheel and a modulated X-ray source capable of providing pulsed X-ray lines at multiple energies similar to that used on *Athena*'s X-IFU and *Hitomi*'s SXS for in-flight calibration. ([Lynx Report](#), §6.3.4.1, p. 129)



TECHNOLOGY IMPLEMENTATION - MISSION DESIGN QUESTION 1

Provide a brief descriptive overview of the mission design (launch, launch vehicle, orbit, pointing strategy) and how it achieves the science requirements (e.g. if you need to cover the entire sky, how is it achieved?).

The *Lynx* mission design allows flexible launch options, discussed in [Lynx Report](#), §6.5, pp. 148–149. We assume a heavy class vehicle with properties similar to a Delta IV Heavy will be available. [Figure 6.34 in Lynx Report \(p.148\)](#) shows the observatory ready for launch. An alternate launch possibility uses an extendable optical bench to launch as a co-manifested payload as shown in [Fig. 6.35 on p.149](#). [Figure 6.28 \(p.139\)](#) shows the timeline for a heavy class launch, a parking orbit, and trajectory to a SE L2 halo orbit, and details are discussed in [Lynx Report](#), §6.7.1 (p.170). Launch vehicle trade is presented in [Lynx Report](#), Appendix B.1.3 (p.298), and the orbit trade is presented in [Appendix B.1.2 \(p.297\)](#).

The pointing strategy is solidly based on the *Chandra* heritage.

Lynx achieves its scientific requirements by carrying out a program entirely driven by the peer-reviewed General Observer specifications to point at given target positions for approved time durations. These comprise almost the entire observing program, along with targets of opportunity, calibrations expected to take a few percent of real time, and any proprietary time (TBD) which NASA might award to the instrument development teams. [Lynx Report](#), §6.7.2 (pp. 170–172) discusses scheduling, maneuvering, and pointing to acquire the science data. The spacecraft is required to point only within 10” of the desired target, and is allowed to jitter about that position by 0.17” per second. On the ground, the science data center uses star measurements from the aspect camera and uses gyro rate data to reconstruct the image, photon-by-photon, to a precision of <0.2” and to register the instrument pixels to the celestial sphere within 1” absolute. *Lynx* can point anywhere on the sky outside of a 45° cone about the sun due to solar panels which can rotate about the pitch axis to keep the power cells perpendicular to the solar vector.

**TECHNOLOGY IMPLEMENTATION - MISSION DESIGN
QUESTION 2**

Describe all mission software development, ground station development and any science development required during Phases B and C/D.

Software for ground operations is discussed in [Lynx Report, §6.7.4, \(pp. 174–176\)](#). On-board software for the spacecraft and focal plane instruments will be developed during Phases B and C/D. Software for the spacecraft computer is discussed in [Lynx Report, §6.4.5, \(pp. 143–144\)](#). Flight software will control communications and data handling, maneuvering and attitude control, recorder management for housekeeping and science data, spacecraft health and safety monitoring, aspect camera operation, electrical power, thermal control, and will be responsible for recognizing fault conditions and managing safe modes. Safe mode control will include a separate set of control processing electronics that operate with different software. Key parameters are summarized in [Table 6.18 of the Lynx Report \(p.143\)](#).

The focal plane instruments will include software that will reside in the electronics units developed by each science instrument provider. This software will receive, decode and respond to uplinked commands passed from the spacecraft, configure the instrument(s), control for performing observations or calibrations, acquire data, select events, correlate with timing signals from the spacecraft, perform status and safety checks, collect housekeeping, engineering and diagnostic data, and format data to pass to the spacecraft for storage and eventual down-link.

**TECHNOLOGY IMPLEMENTATION - MISSION DESIGN
QUESTION 3**

Provide entries in the mission design table. For mass and power, provide contingency if it has been allocated. If not, use 30% contingency.
To calculate margin, take the difference between the maximum possible value (e.g. launch vehicle capability) and the maximum expected value (CBE plus contingency).

The Mission Design Table can be found on the next page.

We also refer the reader to the [MEL+PEL supplements](#), and to [Table D.1 of the Lynx Report \(p.313\)](#).

Answer continued on next page



Table 9. *Lynx* Mission Design Table

Parameter	Value / Note	Units
Orbit Parameters (apogee, perigee, inclination, etc.)	800,000 × 500,000 Halo orbit around SE L2	km
Mission Lifetime	60 (design) 240 (capability)	months
Maximum Eclipse Period	0	min
Launch Site	KSC	
Spacecraft Dry Bus* Mass without contingency	2,044.47	kg
Spacecraft Dry Bus* Mass contingency	23.25	%
Spacecraft Dry Bus* Mass with contingency	2,519.51	kg
Spacecraft Propellant Mass without contingency [†]	537	kg
Spacecraft Propellant contingency [†]	0	%
Spacecraft Propellant Mass with contingency [†]	537	kg
Launch Vehicle	Future Heavy Launch; 10,000 kg capacity; 5 m Faring	N/A
Launch Vehicle Mass Margin [= Launch Vehicle Limit – (Observatory CBE + MGA) = 10,000 kg – (6,299 kg + 1,413 kg)]	2,286	kg
Launch Vehicle Mass Margin (%)	22.9	% of vehicle capability
Spacecraft Bus* Power (Science Mode) without contingency	2,138	W
Spacecraft Bus* Power contingency	40	%
Spacecraft Bus* Power (Science Mode) with contingency	2,993	W

* Excluding the payload (mirror, optical bench, & science instruments)

[†] 5% unusable propellant assumed. Also note that the *Lynx* DRM design carries propellant for a 20 year mission lifetime while the baseline mission is 5 years

The MGA was determined for individual subsystem elements based on AIAA guidelines, the values of which varies as a function of hardware type (e.g., electrical components, structure, thermal control, propulsion, mechanisms, etc..) and maturity.



TECHNOLOGY IMPLEMENTATION - MISSION DESIGN
QUESTION 4

Provide any existing block diagrams or drawings showing the observatory (payload and s/c) with the instruments and other components labeled and a descriptive caption. Provide a diagram of the observatory in the launch vehicle fairing indicating clearance if you have it.

A diagram of the complete observatory is shown in Fig 6.4 of the [Lynx Report](#) (p.105, reproduced below). Figure 6.5 of the [Lynx Report](#) (p.106, reproduced below) shows details of the mirror assembly and attachments to the gratings, optical bench, and spacecraft bus.

The science instrument module is shown in Fig 6.6 of the [Lynx Report](#) (p.107, reproduced below), and the focal plane instruments in Fig 6.24 of the [Lynx Report](#) (p.134, reproduced below).

A more detailed schematic of the spacecraft bus is shown in Fig 6.27 of the [Lynx Report](#) (p.137, reproduced below).

A diagram of the observatory in the baseline choice of a heavy class lift vehicle is shown in Fig 6.34 of the [Lynx Report](#) (p.148, reproduced below). An alternate launch possibility uses an extendable optical bench to launch as a co-manifested payload as shown in Fig 6.35 of the [Lynx Report](#) (p.149).

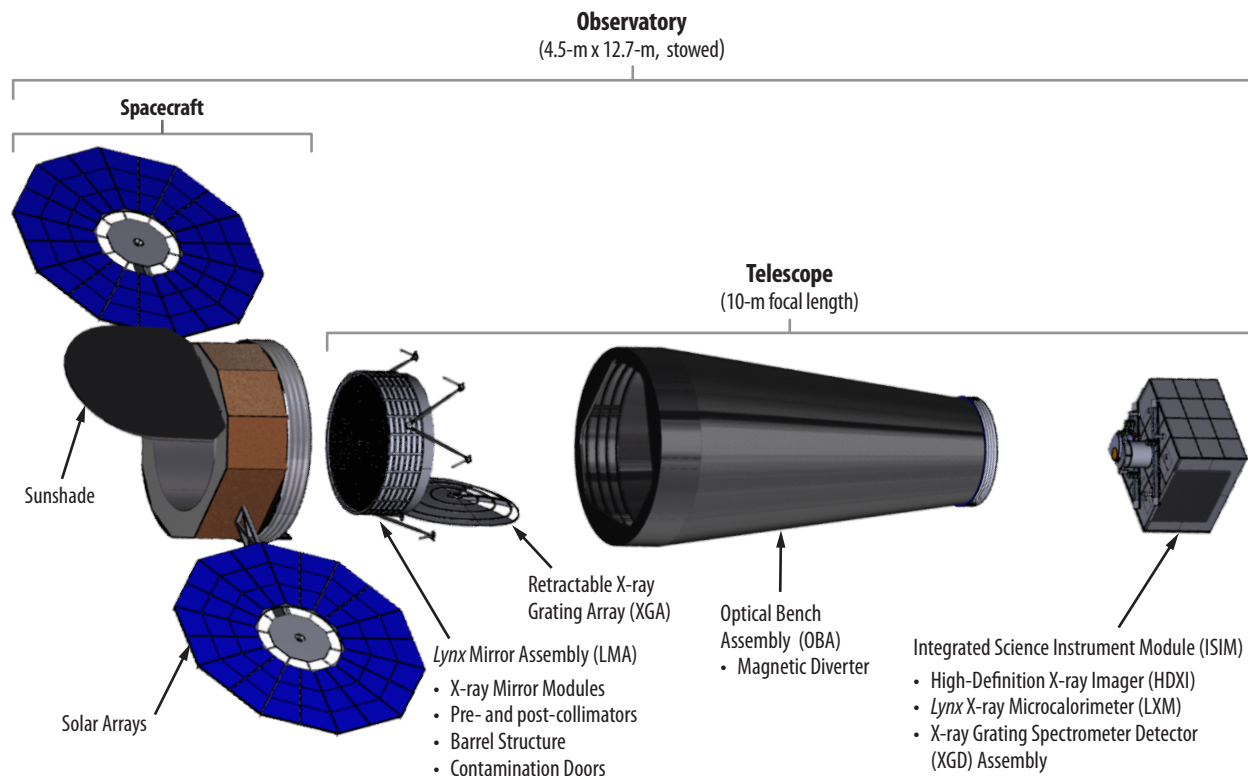

Figure 6.4. *Lynx* configuration expanded to show the telescope and spacecraft portions of the Observatory. The LMA is surrounded by the spacecraft and consists of a high-resolution, large-area mirror assembly with pre- and post-collimators and contamination doors. A retractable X-ray Grating Array (XGA) is attached just after the LMA. A fixed OBA ties the LMA to the science instruments that include HDXI, LXM, and XGS, where the XGS is comprised of the XGA and X-ray Grating Detector (XGD) assembly. [Credit: NASA/M. Baysinger]

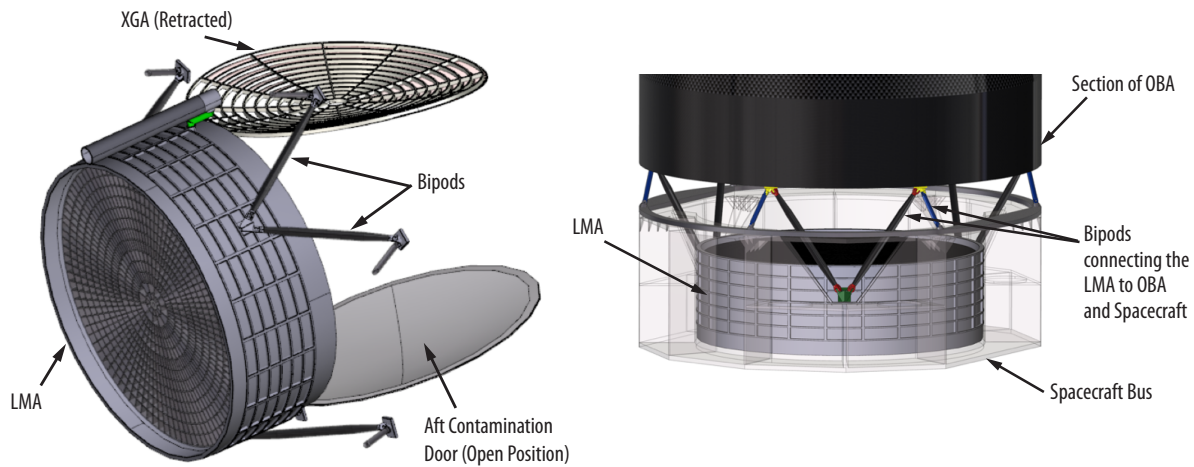

Figure 6.5. Drawing of the LMA with the XGA in the retracted position and aft-contamination door open. Bipods are used to attach the LMA to the OBA and from the OBA to the spacecraft bus.

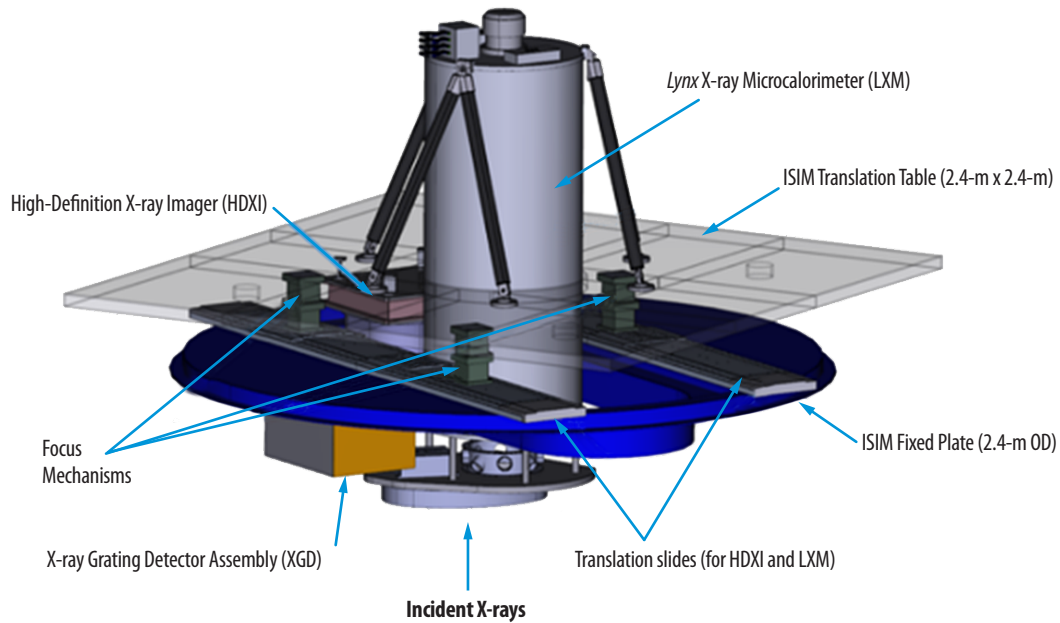

Figure 6.6. ISIM with the translation table shown in translucent-gray, to which HDXI and LXM are attached. The HDXI and LXM can be translated on-axis, depending on the desired science measurement. Three focusing mechanisms allow for fine focus of the HDXI and LXM. The XGD assembly is mounted to the ISIM fixed plate, and has a focus mechanism built into its housing. The electronics boxes for the instruments and the radiators are not shown in this view.

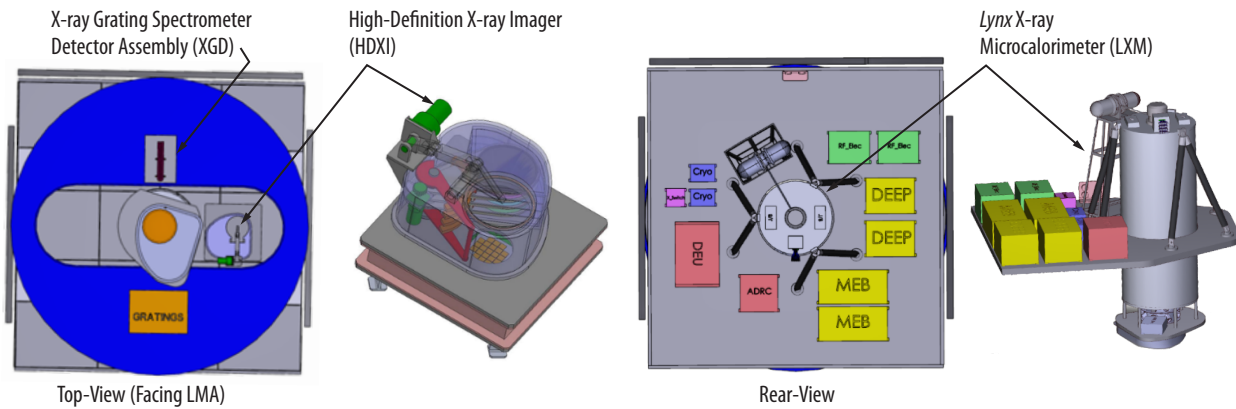

Figure 6.24. Views of the ISIM with HDXI, XGD, and LXM mounted, along with a view of their electronics boxes. An elliptical opening, seen in the top-view in the ISIM fixed plate allows for the HDXI and LXM to translate across the focal plane.

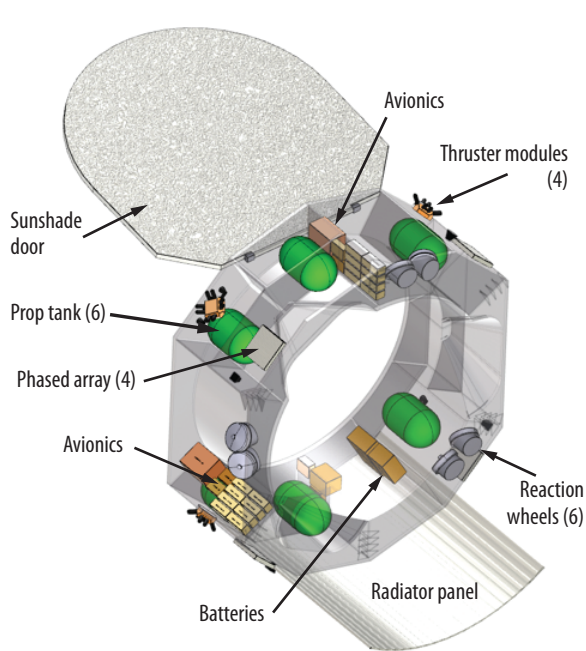
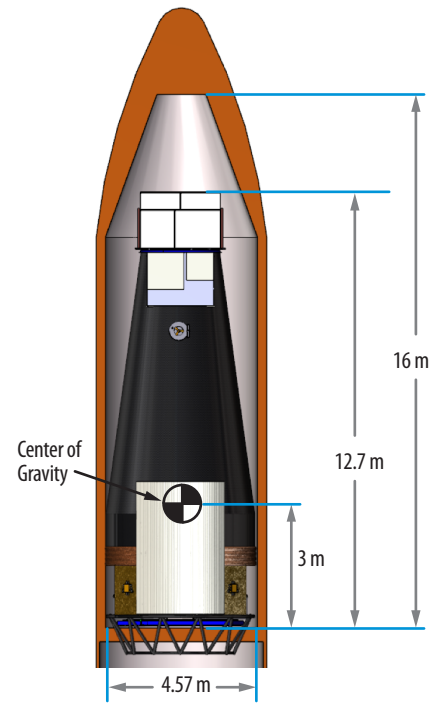

Figure 6.27. *Lynx* spacecraft schematic. All spacecraft subsystems are at high maturity levels or modified heritage.



Lynx Launch Configuration Future Heavy-lift LV Shroud
 Figure 6.34. *Lynx* fits within the payload envelope and can launch on a future Heavy-class vehicle to SE-L2 with sufficient mass growth allowance and launch vehicle margin.



TECHNOLOGY IMPLEMENTATION - MISSION DESIGN
QUESTION 5

For the mission, what are the three primary risks?

Programmatic risks are presented in [Lynx Report, §8.3](#). Determination of the on-orbit risks requires future detailed systems engineering study of the actual flight design. *Lynx* will be subject to “generic” risks such as launch vehicle failure, vibration or acoustic damage to mechanisms during launch, and failure of a science instrument thus reducing the scope of scientific observations. Extensive ground testing and analysis are planned to mitigate the latter two risks. These risks have likelihood 1 or 2, and consequence 4 or 5 (c.f. [Fig. 8.2 of the Lynx Report, p.219](#)).

No Risks associated with the Mission are in the top *Lynx* Risks.

TECHNOLOGY IMPLEMENTATION - MISSION DESIGN
QUESTION 6

Provide an estimate of the required propellant, if applicable

Lynx requires 488 kg of hydrazine propellant to perform all Δ -V maneuvers, including 20 years of station-keeping, and perform all momentum unloading for 20 years of celestial observations. The Δ -V requirements are discussed in [Lynx Report, §6.4.3 \(p.138\)](#), and summarized in [Fig. 6.28 \(p.139\)](#). Of the 488 kg, 62 kg are estimated to be used for momentum unloading. In addition to the 488 kg, we assume 5%, or 24.4 kg, residual unusable hydrazine, and 23.3 kg of gaseous N₂ pressurant.

**TECHNOLOGY IMPLEMENTATION - SPACECRAFT
QUESTION 1**

Describe the spacecraft characteristics and requirements.
Include a preliminary description of the spacecraft design and a summary of
the estimated performance of the key spacecraft subsystems.
Please fill out the Spacecraft Mass Table.

Primary reference: [Lynx Report](#), §6.3.6 (p.135) and §6.4 (pp.137–147)

The *Lynx* spacecraft requirements have been traced from science requirements, instrument requirements, mission (launch vehicle) requirements and operational requirements (see *Lynx* Mission Trace Matrix in [Table FO3 of the Lynx Report](#), p.180). All requirements can be met with margin using the design described in the *Lynx* Final Report using high TRL/flight heritage design solutions. *Lynx* uses the flight proven *Chandra* design architecture with updated components/sub-systems as appropriate to improve reliability and increase performance and mass margins and leverage the investment made during the *Chandra* Program to reduce cost and Risk.

**TECHNOLOGY IMPLEMENTATION - SPACECRAFT
QUESTION 2**

Provide a brief description and an overall assessment of the technical maturity of the spacecraft subsystems and critical components. Provide TRL levels of key units, and in particular, identify any required new technologies or developments or open implementation issues.

Primary reference: [Lynx Report](#), §6.3.6 (p.135), §6.4 (pp. 137–147), MEL Table D.1 (pp.313–316)

All *Lynx* spacecraft subsystems can meet requirements with high TRL (TRL 6+) design solutions. No new technologies or development activities are required for the spacecraft element. To further improve margins, future trade studies will assess lower TRL design solutions, balancing risk with margin improvements (see answer to question 3 below).

**TECHNOLOGY IMPLEMENTATION - SPACECRAFT
QUESTION 3**

Identify and describe the three lowest TRL units, state the TRL level and explain how and when these units will reach TRL 6. Summarize the TRL of all units less than TRL 4.

Primary reference: [Lynx Report](#), MEL Table D.1 (pp.313–316)

As shown in the MEL, most spacecraft components are TRL 9, a small number are currently TRL 6+ with a clear, low risk path to maturation. No components of the spacecraft lower than TRL 4. A few chosen components are lower than TRL 6, this is done to maximize performance margin but higher TRL design solutions that meet requirements are available. Examples are:

- **Propellant tanks:** a stretched version of existing ATK80274 tanks. Low risk modification.
- **Radiators:** High performance TRL 4 radiators were chosen to increase mass margin. TRL 9 radiators will meet thermal requirements with minor ($\approx 78\text{kg}$) mass increase.
- **OBA Sunshade:** A one-time deployable Si-Kapton observatory sunshade (TRL 5) was chosen to increase on-orbit lifetime compared to conventional MLI. This sunshade uses high TRL materials but is a new design.

**TECHNOLOGY IMPLEMENTATION - SPACECRAFT
QUESTION 4**

Please provide a Master Equipment List (MEL) for the spacecraft components indicating mass and power of each component at the level of specificity known.

The [MEL+PEL spreadsheet](#) is included as an attachment to this RFI response. See also [Lynx Report](#), MEL Table D.1 (pp.313–316).

**TECHNOLOGY IMPLEMENTATION - SPACECRAFT
QUESTION 5**

What are the three greatest risks with the spacecraft?

Primary reference: [Lynx Report](#), §8.3 (pp. 218–223) and Risk Matrix in Fig. 8.2 (p.219).

No risks associated with the spacecraft are in the top *Lynx* risks.



TECHNOLOGY IMPLEMENTATION - SPACECRAFT QUESTION 6

If you have required new S/C technologies, developments or if there are open issues, describe the plans to address them (to answer you may point to technology implementation plan reports or concept study reports, but please enumerate the relevant pages).

Primary reference: [Lynx Report](#), §6.4 (pp.137–147)

The *Lynx* spacecraft can meet all requirements with high TRL design solutions with margin. No new spacecraft technologies or development is required. *Lynx* will take advantage of emerging technologies as appropriate to reduce risk and increase margins and can do this without expensive architecture changes. After trade studies, the *Chandra* architecture was chosen for *Lynx* which allows all requirements to be met while maximizing the investment in *Chandra* and leveraging *Chandra* AI&T experience.

TECHNOLOGY IMPLEMENTATION - SPACECRAFT QUESTION 7

Describe subsystem characteristics and requirements to the extent possible. Describe in more detail those subsystems that are less mature or have driving requirements for mission success. Such characteristics include: mass, volume, and power; pointing knowledge and accuracy; data rates; and a summary of margins. Comment on how these mass and power numbers relate to existing technology and what light weighting or power reduction is required to achieve your goals.

Primary reference: [Lynx Report](#), §6.4 (pp.137–147), §6.6.1 (pp. 152–158), and §6.6.2 (pp. 159–161).

Lynx subsystem design is detailed in the Report. A detailed MEL and power schedule (a Power Equipment List analyzed with operational modes and duty cycle), and component TRLs is included in the report. The MEL and PEL spreadsheets are provided as attachments to this RFI response. All driving requirements can be met with margin and error budgets and analyses have been done to show this ([Lynx Report](#), §6.6.1). The *Lynx* Observatory can be accommodated by a Heavy Class Launch vehicle with margin. No light weighting or power reductions are required to meet goals. As *Lynx* moves to detailed design, opportunities to increase margins will be considered with technical and programmatic (cost and schedule) Risk considered. The overall *Lynx* design philosophy is for a high TRL, low risk spacecraft.

**TECHNOLOGY IMPLEMENTATION - SPACECRAFT
QUESTION 8**

Describe the flight heritage of the spacecraft and its subsystems. Indicate items that are to be developed, as well as any existing hardware or design/flight heritage.

Discuss the steps needed for space qualification.

Spacecraft subsystems are described in [Lynx Report, §6.4 \(pp.137–147\)](#). Further information is contained in the [MEL+PEL spreadsheets](#) attached to this RFI response and in the [Supplemental DRM Design Package](#) available upon request.

Lynx does not require any new technology elements for the spacecraft nor its subsystems. All risk and new development for *Lynx* is isolated to its optics and science instruments. With few exceptions, the spacecraft components are either flight proven (TRL 9) or are considered low-risk modifications from existing space-qualified hardware and rated TRL 6-8 (e.g., hardware controllers, cabling, etc). The exceptions are (1) heater controllers that are commercially available but not yet space qualified (avionics: [p.144 of Lynx Report](#)), (2) certain lightweight heatpipe radiator panels that are not yet environmentally tested although space-qualified panels are available that are heavier (thermal: [p.143 of Lynx Report](#)), (3) COTS thrusters that are not yet flight tested and a custom-sized propellant tank that is a modification of flight-proven hardware (propulsion: [p.137 of Lynx Report](#)), and (4) OBA-mounted sunshade ([p.143 of Lynx Report](#), see also pp. 102–110 of the [Supplemental DRM Design Package](#)).

Lynx spacecraft and subsystems benefit greatly from past and current missions, particularly *Chandra* (see [Table 8.9 in Lynx Report, p.240](#) for functional comparisons and analogies to *Chandra*). The following table lists baselined components from the *Lynx* design MEL showing additional design and flight heritage examples:

Answer continued on next page



Table 10. Baselined components from the *Lynx* design MEL showing additional design and flight heritage examples:

Subsystem	Item	Baseline	Design / Flight Heritage
PCAD	Star Tracker	Ball Aerospace CT-601 HAST	<i>Chandra</i> , CRSS, EOS, SWAS, WIRE, MSX, XTE
PCAD	Inertia reference	Honeywell miniature Inertial measurement unit: GG1320 Ring Laser Gyro	GG1320 Ring Laser Gyro Extensive, including deep space applications
PCAD	Sun Sensors	Adcole Coarse: Four 2pi ster Fine: two 64 x 64 deg.	Many, e.g., AMOS-1, AMOS-2, TRMM, OICETS, XMM, JEM< A2100, A2100M, TOMS, QUIK TOMS, N-STAR, COMETS, DRTS, ETS-8, CLASSIFIED PROGRAMS
PCAD	Fiducial System	LEDs, cube corner reflectors	Standard parts, used on <i>Chandra</i> .
PCAD	Reaction Wheels	Rockwell Collins, TEL-DIX RDR 68-3	<i>Chandra</i>
C&DH	Computer	JPL, Uses BAE Systems RAD750 SBC	JPL Mars Orbiter
C&DH	Solid State Recorder	EADS Astrium Coreci	KazEOSat-1/2, SPOT-6/7 on AstroBus-L
C&DH	X-band transponder	General Dynamics SDST	Deep Space-1, Mars Odyssey, Spitzer, MRO, others
C&DH	Ka transceiver	Harris Ka-band SDR	
C&DH	Traveling wave tube amplifiers	Thales, TH4626C Thales, TH4604C	Solar Probe Plus, JWST Hershel, Stereo A/B
C&DH	Antenna	Phase Array	Mercury Messenger
Propulsion	Delta-V thrusters	Northrop-Grumman MRE-15	TRL-6
Propulsion	Momentum unloading thrusters	Northrop Grumman MRE-1.0	Pioneer, HEAO, TDRSS, FLTSATCOM, EOS, SSTI, SOHO, TOMS, KOMP-SAT, (others)
Propulsion	Propellant tank	ATK 80274, modified	To be lengthened for <i>Lynx</i>
Power	Solar Arrays	Northrop-Grumman Ultra-Flex	Orbital ATK CRS Cygnus, Mars Phoenix Lander

**Response to Technology Implementation - Spacecraft Question 8 (continued)**

In a broader context, *Lynx* also benefits greatly from *Chandra* heritage in its architecture and operations concept. *Chandra* heritage architecture includes:

1. placing the spacecraft around *Lynx* Mirror Assembly (LMA) to ease the thermal environment (mirrors operate at room temperature) and for mass balance and distribution,
2. bi-pod attachments of LMA to the Optical Bench Assembly (OBA; s/c attaches to OBA independently) for vibe & thermal control,
3. PCAD-like GN&C (including *Chandra*-like fiducial light transfer system),
4. retractable XGA and translatable ISIM table for HDXI/LXM selection, and
5. sunshade/forward contamination door.

**TECHNOLOGY IMPLEMENTATION - SPACECRAFT
QUESTION 9**

Address to the extent possible the accommodation of the science instruments by the spacecraft. In particular, identify any challenging or non-standard requirements (i.e. Jitter/momentum considerations, thermal environment/temperature limits etc).

Primary reference: [Lynx Report](#), §6.3.1.2 (pp.111–113) for *Lynx* Mirror Assembly, §6.3.2.2 (pp. 117–118) for HDXI, 6.3.3.2 (pp. 123–124) for XGS, and 6.3.4.2 (pp. 131–133) for LXM.

The planned spacecraft is standard and is designed to accommodate the *Lynx* payload elements without stressing the spacecraft system. Performance considerations for each of the enabling technologies are detailed in the above Sections of the Concept Study Report. Critical design features include considerations for contamination (both on the ground and on-orbit), thermal control, radiation, maintaining alignment, vibration, and launch survivability.

**TECHNOLOGY IMPLEMENTATION - SPACECRAFT
QUESTION 10**

Provide a schedule for the spacecraft, indicate the organization responsible and describe briefly past experience with similar spacecraft buses.

Primary reference: [Lynx DRM Project Schedule](#) attached to this RFI response, see IDs 180–191. This schedule includes all major Project reviews, I&T, fabrication and test, and delivery for integration with the payload elements.

[Lynx Report](#), §6.6.3.5 (p.165) details the spacecraft element I&T flow and §6.6.3.6 (p.168) and [Figure 6.53 \(reproduced on the next page\)](#) provides a timeline that includes the spacecraft element I&T. The spacecraft element procurement will be a competed activity (provided by the prime contractor.) Because it will be competed, it is assumed that the responsible organization will have experience with similar spacecraft buses. The *Lynx* spacecraft bus is standard and does not require any new developments.

**TECHNOLOGY IMPLEMENTATION - SPACECRAFT
QUESTIONS**

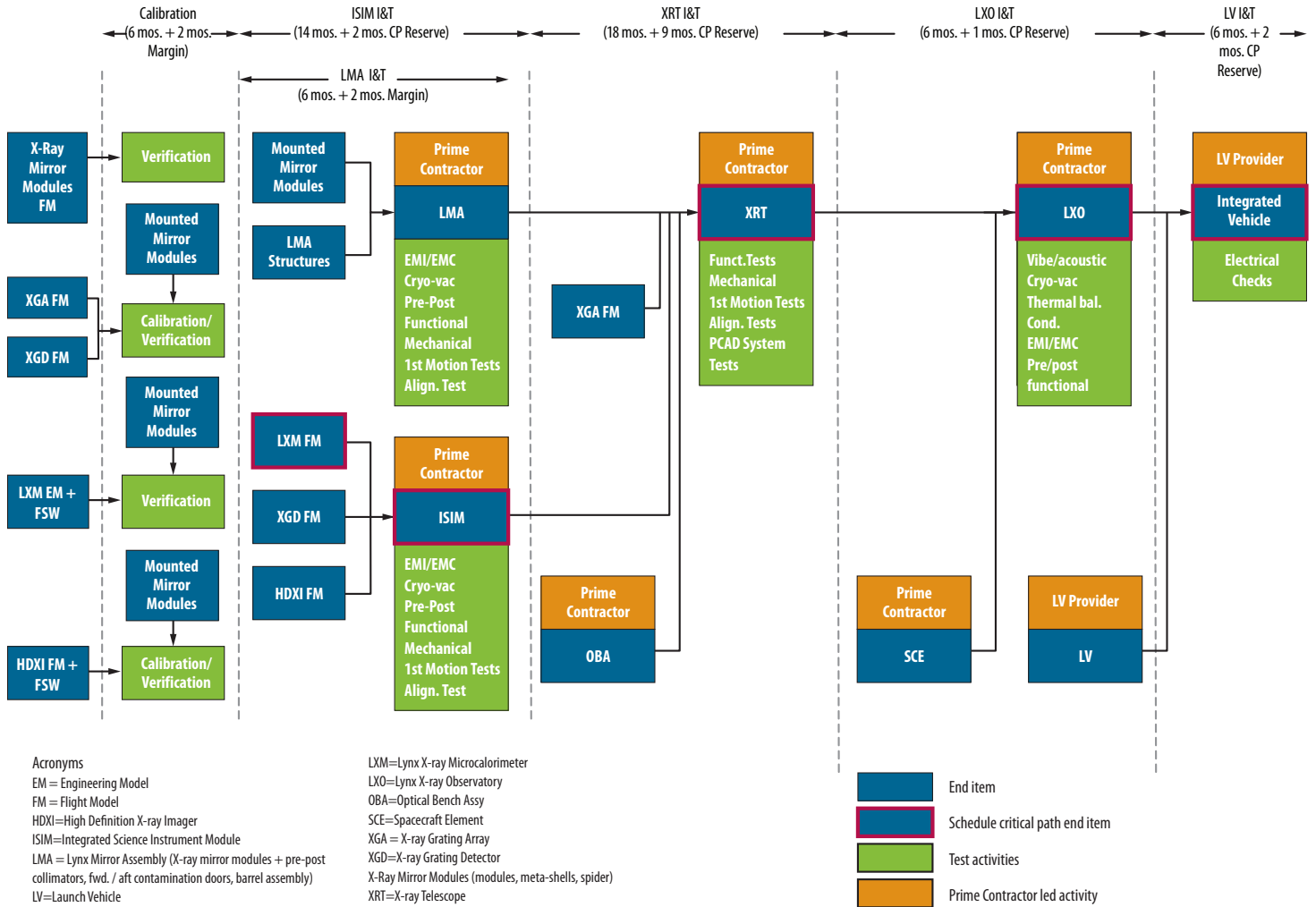

Figure 6.53. Lynx AI&T flow

TECHNOLOGY IMPLEMENTATION - SPACECRAFT QUESTION 11
 Describe any instrumentation or spacecraft hardware that requires non-US participation for mission success.

None.



**TECHNOLOGY IMPLEMENTATION - SPACECRAFT
QUESTION 12**

Fill out the Spacecraft Characteristics Table

The Spacecraft Mass Table follows below, while the Spacecraft Characteristics Table continues on the next page.

Table 11. Mass values for the Spacecraft Bus

Spacecraft Bus	Current Best Estimate (CBE), kg	Mass Contingency	CBE Plus Contingency, kg
Structures & Mechanisms	755.40	25%	944.24
Thermal Control	176.47	20%	211.76
Propulsion (Dry Mass)	114.97	15.4%	132.69
Attitude Control	151.32	17.8%	178.24
Command & Data Handling	368.24	18.8%	437.33
Telecommunications	103.07	9.1%	112.49
Power System	374.8	34%	502.75
Total Spacecraft Dry Buss Mass	2044.27	23.2%	2519.5

The MGA was determined for individual subsystem elements based on AIAA guidelines, the values of which varies as a function of hardware type (e.g., electrical components, structure, thermal control, propulsion, mechanisms, etc..) and maturity.

The Spacecraft Characteristics Table follows



Table 12. Baselined components from the *Lynx* design MEL showing additional design and flight heritage examples:

Spacecraft Bus	Value / Summary / Units
Structure	See Lynx Report , §6.3.6 (pp.135–136), and §6.4 (p.137)
Structures material (aluminum, exotic, composite, etc.)	Aluminum and composites, all with flight heritage materials
Number of articulated structures	Two solar panels
Number of deployed structures	One sunshade door, one OBA sunshade panel.
Thermal Control	See Lynx Report , §6.4.4 (pp.142–143)
Type of thermal control used	Si-Kapton sunshade, MLI & OSR, active heater control, heat pipes and radiators.
Propulsion	See Lynx Report , §6.4.1 (pp.137–139)
Estimated delta-V budget, m/s	107.1 m/s
Propulsion type(s) and associated propellant(s)/oxidizer(s)	Monopropellant, Hydrazine, blowdown system with N ₂ Pressurant.
Number of thrusters and tanks	2+2 redundant NG MRE-15 main engines, 8 + 8 redundant MRE-1.0 RCS/ACS thruster modules, 6 modified ATK 80274 tanks.
Specific impulse of each propulsion mode, seconds	Isp varies by mode and tank pressure. Approximate Isp at start of mission are: MRE-1.0 224s, MRE-15 230s
Attitude Control	See Lynx Report , §6.4.2 (pp.139–141)
Control method (3-axis, spinner, grav-gradient, etc.).	3-axis
Control reference (solar, inertial, Earth-nadir, Earth-limb, etc.)	star trackers, sun sensors, IMUs
Attitude control capability, degrees	<4.7×10 ⁻⁵
Attitude knowledge limit, degrees	0.00111
Agility requirements (maneuvers, scanning, etc.)	Slew 90degrees in 50 minutes
Articulation/#-axes (solar arrays, antennas, gimbals, etc.)	Solar arrays rotate about pitch to maintain sun normal within 1 degree



Table 12. Spacecraft Characteristics Table (*continued*)

Sensor and actuator information (precision/errors, torque, momentum storage capabilities, etc.)	IRU drift rates Momentum wheels: maximum torque 0.42 N m. Operational torque 0.27 N m. Maximum momentum storage 204 N m s. Operational momentum storage 102 N m s.
Command & Data Handling	
Spacecraft housekeeping data rate, kbps	200
Data storage capacity, Mbits	512,000
Maximum storage record rate, kbps	2,777
Maximum storage playback rate, kbps	22,200
Power	
Type of array structure (rigid, flexible, body mounted, deployed, articulated)	Deployed, articulated about the pitch axis
Array size, meters × meters	Two 10-sided, quasi-circular with 5.7m diameter. 51 square meters total area.
Solar cell type (Si, GaAs, Multi-junction GaAs, concentrators)	Inverted MetaMorphic (IMM) solar cells (Multi-junction GaAs with III-V compounds.)
Expected power generation at Beginning of Life (BOL) and End of Life (EOL), watts	10400 W BOL 7421 W EOL (20 years)
On-orbit average power consumption, watts	7421 W Peak. (average is up to 200W less depending on peer review selected use of instruments)
Battery type (NiCd, NiH, Li-ion)	Li-ion
Battery storage capacity, amp-hours	83 (6 batteries)



TECHNOLOGY IMPLEMENTATION - SPACECRAFT
QUESTION 13

Provide any special requirements such as contamination control
or electro-magnetic controls (EMC).

The *Lynx* spacecraft bus is standard and does not require any new developments or especially challenging contamination control or electromagnetic control (or other). However, contamination control has been considered as part of the *Lynx* design study, and discussion can be found in:

[Lynx Report](#), §6.3, p.106: Design of the Telescope Elements

[Lynx Report](#), §6.7.1, p.170: Launch to Orbit — Cruise, Commissioning, and Check-Out

[Lynx Report](#), §6.7.5, p.177: Serviceability

As part of the *Lynx* Mission Design Lab run at GSFC, a Contamination Control Study was completed and cleanliness requirements per FED-STD-CC1246E were considered on the star trackers, solar arrays, thermal blankets, radiators, spacecraft bus, and sunshade. Standard venting on the spacecraft bus will be considered, thermal blankets will be designed for low outgassing, and launch services will consider a black light fairing cleaning. Low outgassing materials will be considered for the sunshade (no bare aluminum). These are just a few examples, and the contamination control analysis can be provided if requested.

Lynx does not have any unusual requirements on the spacecraft contamination, but the spacecraft does accommodate contamination control of the payload elements, as do the *Lynx* Mirror Assembly and science instruments. A few examples include the following:

[Lynx Report](#), §6.3.1.2, pp. 111–113: *Lynx* Mirror Assembly Performance Considerations

[Lynx Report](#), §6.3.2.2, pp. 117–118: HDXI Performance Considerations

[Lynx Report](#), §6.3.3.2, pp. 123–124: XGS Performance Considerations

[Lynx Report](#), §6.3.4.2, pp. 131–134: LXM Performance Considerations

[Lynx Report](#), §6.3.6, p. 136: Optical Bench Assembly, regarding the use of a magnetic diverter

[Lynx Report](#), §6.4.4, p. 142, paragraph 1



ENABLING TECHNOLOGY QUESTION 1

For any technologies that have not been demonstrated by sub-scale or full-scale models, please describe a description of the technical maturity, including the description of analysis or hardware development activities to date, and the associated technology maturation plan.

Lynx has four enabling technologies: an X-ray mirror assembly and three science instruments. One of multiple (2 or 3) feasible alternatives was selected for each of these technologies for purposes of in-depth cost, schedule, and system integration evaluation in the [Lynx Report](#). These technologies have matured to TRL 3 or higher, with some elements or components at a higher TRL, as assessed by the most recent Physics of the Cosmos (PCOS) Technology Management Board assessment in 2019. These four selected technologies are

- **Silicon Meta-shell Optics** ([SMO Technology Roadmap](#))
- **High-Definition X-ray Imager** ([HDXI Technology Roadmap](#))
- **Critical-Angle Transmission Gratings** ([XGS Technology Roadmap](#))
- **Lynx X-ray Microcalorimeter** ([LXM Technology Roadmap](#))

where the URLs point to publicly available technology development plans supplemental to the *Lynx* Report. [Lynx Report](#), §7 (pp.182–214), summarizes these plans and those of the recognized feasible alternatives (see also [Lynx Technology Pages](#), <https://www.wastro.msfc.nasa.gov/lynx/docs/documents/Technology> for a complete list). Each of these technology development plans describe present reviews of the state-of-the-art; descriptions of the technical elements being developed, tested, and verified; statements of TRL 4, 5, and 6 specific to each technology; assessments of the key milestone elements (with Advancement Degree of Difficulty (AD2) evaluations) needed to advance each technology to successive TRL levels; and estimates of the associated schedules, costs, risks, and risk mitigations. The technology plans follow the development paths from the current State of the Art to TRL 5 by the start of Phase A (KDP-A; October 1, 2024) and to TRL 6 by Preliminary Design Review (PDR; February 1, 2028).

ENABLING TECHNOLOGY QUESTION 2

Describe the aspect of the enabling technology that is critical to the mission's success, and the sensitivity of mission performance if the technology is not realized or is only partially realized.

The *Lynx* team has assessed each of the enabling technologies and identified significant risks in the technology maturation stage (up to mission PDR) as reported in the respective [Technology Roadmaps](#):

- Optics: [SMO Technology Roadmap](#), pp. 23–24
- HDXI: [HDXI Technology Roadmap](#), pp. 18–21
- XGS: [XGS Gratings Technology Roadmap](#), pp. 17–20
- LXM: [LXM Technology Roadmap](#), pp. 47–50

The team has also assessed technology risks to the *Lynx* mission success at the programmatic level. These are reported in [Lynx Report](#), §8.3 (pp.218–223). These latter, mission-level, risks (and impacts) include (Likelihood>1 AND Consequence>2):

- The inability to demonstrate and scale up mirror module assembly and alignment (increased cost

Answer continued on next page

**Response to Enabling Technology Question 2 (continued)**

and schedule)

- The inability or delay of the LXM to achieve maturation to TRL 6 (reduced science capability or increased cost and schedule for technology development (Phase C start delay))
- The inability to elevate the mirror segment manufacturing process to industrial-scale production while maintaining technical requirements (increased cost and prolonged schedule)
- The inability to fabricate, assemble, and test the LXM within projected timescale (critical path schedule margin reduction and increased project cost)

**ENABLING TECHNOLOGY
QUESTION 3**

Provide specific cost and schedule assumptions by year for all developmental activities, and the specific efforts that allow the technology to be ready when required, as well as an outline of readiness tests to confirm technical readiness level.

The high-level technology development schedule is given in [Lynx Report, Fig. 7.1 \(p.186, reproduced on page 69\)](#). The following table provides estimated TRL completion dates and references to the [Technology Roadmaps](#). Those references provide (a) the Key Milestone Elements (i.e., developmental activities) needed to advance TRL including estimated milestone significance, and verification methodologies for each of the four enabling technologies and (b) references to Schedule details figures and text. On average, there are ~8 key milestones identified for each enabling technology for each TRL of advancement. These public [Technology Roadmaps](#) do not include budgetary information although grassroots estimates have been made that can bring each technology to the required TRL on schedule and consistent with expected funding levels during the development stage.

Answer continued on next page



Response to **Enabling Technology** Question 3 (*continued*)

Table 13. TRL Milestones for Enabling Technologies

TRL	Completion Date	Key Milestone Elements	Schedule
Silicon Metashell Optics, see SMO Technology Roadmap			
TRL 4	Q2/2021	Table 4, p.16; text p.18-19	Figure 8, p.22
TRL 5	Q4/2023	Table 4, p.17; text p.19-20	
TRL 6	Q4/2026	Table 4, p.18, text p.20-21	
High Definition X-ray Imager (HDXI), seen HDXI Technology Roadmap			
TRL 4	Q3/2024	Table 5, p.9; text p.11-14	p. 15-16; Fig.5, p.17
TRL 5	Q3/2026	Table 5, p.10; text p.14	
TRL 6	Q4/2027	Table 5, p.11; text p.15	
Critical Angle Transmission X-ray Grating Spectrometer (XGS) Array, see XGS Technology Roadmap			
TRL 5	Q4/2021	Table 6, p.10; text p.11-13	Figure 8, p.16 (redacted)
TRL 6	Q3/2024	Table 6, p.11; text p.13-15	
Lynx X-ray Microcalorimeter, see LXM Technology Roadmap			
TRL 4	Q4/2021	Table 7, p.25-27; text p.31-44	p.44-45; Fig.19, p. 46
TRL 5	Q4/2023	Table 7, p.27-29; text p. 31-44	
TRL 6	Q2/2027	Table 7, p.30; text p. 31-44	

**ENABLING TECHNOLOGY
QUESTION 4**

Please indicate any non-US technology required for activity success and what back up plans would be required if only US participation occurred.

There are no non-US technologies required for success of *Lynx*.



MISSION OPERATIONS DEVELOPMENT QUESTION 1

Provide a brief description of mission operations, aimed at communicating the overall complexity of the ground operations (frequency of contacts, reorientations, complexity of mission planning, etc). Analogies with currently operating or recent missions are helpful. If the NASA DSN or NEN networks will be used provide time required per week as well as the number of weeks (timeline) required for the mission.

The Concept for Operations is presented in [Lynx Report, §6.3 \(pp.169–178\)](#), and provides a more comprehensive description for overall Operations, supplemented by the Summary Responses provided for each item below.

Ground communications with *Lynx* are planned as 1-hour contacts, 3 times per day through the DSN. *Lynx* will observe 1-20 targets per day with a total of order 1000-1500 per year. Exposures range from 1ks to as high as 4Ms, with the longer observations split into a number of shorter exposures. Mission planning will be based on a long-term schedule encompassing science targets selected through annual peer reviews along with calibration targets provided by the science and operations center staff. The long-term schedule is broken into one week short-term schedules mixing constrained observations with pool targets to optimize the overall science viewing efficiency (requirement for science time as percentage of wall clock time: 85%; current estimate: ~91%). Detailed command loads and observing sequences are generated on a weekly basis. The planned program may be interrupted at times for peer review recommended Targets of Opportunity (TOOs) or targets approved for Director's Discretionary Time (also treated as TOOs). The mission is planned for a 5-year nominal lifetime with the expectation of extending well beyond that frame. Essentially all aspects of the operations are patterned after the well-established procedures in place for *Chandra*, which have been honed over the past 20 years of operations with substantial improvements in efficiency over that time. One modest difference involves the shortest turn-around time for TOO observation which can be as short as 3 hours after approval for *Lynx* compared to a *Chandra*-minimum of ~16 hours.

MISSION OPERATIONS DEVELOPMENT QUESTION 2

Identify any unusual constraints or special communications, tracking, or near real-time ground support requirements.

Normal operations will all be done on a pre-planned basis with no unusual constraints or special communications requirements, nor near real-time ground support requirements. Range and Doppler tracking data for orbit determination will be obtained by DSN during scheduled passes. In the event of a major spacecraft anomaly, additional communications opportunities may be requested, as has been done a handful of times over the 20 years of the *Chandra* mission. A small number of additional communications are also likely to be requested for mission critical steps which could include solar array deployment, latch releases, telescope and instrument cover and door openings, and orbit adjustments during cruise and insertion to L2.



MISSION OPERATIONS DEVELOPMENT
QUESTION 3

Identify any unusual or especially challenging operational constraints (i.e. viewing or pointing requirements).

None known at this time.

Sun avoidance (~45 degree cone) is built into mission planning and on-orbit safing modes. Very bright X-ray sources are avoided through checks in the normal planning and scheduling process. Observations of “apparently moving” targets such as planets and comets in our solar system may require short pointing maneuvers to keep the target on the focal plane detector, but this is already routinely accomplished with *Chandra*.

MISSION OPERATIONS DEVELOPMENT
QUESTION 4

Describe science and data products in sufficient detail that Phase E costs can be understood compared to the level of effort described in this section.

Primary reference: [Lynx Report](#), §6.7.4, p.174–176.

Nearly all of the *Chandra* hardware and software requirements and algorithms are available for designing the *Lynx* ground operations and science systems. The software heritage is substantial. See [Lynx Report](#), §8.5.3.1 (p.244, paragraph 1) for further details comparing *Lynx* and *Chandra* operations.

In addition, [Cost Book](#), §B.2.3, p.140–153, provides a very detailed grass roots estimate of the *Lynx* Mission Operations (WBS 7), Ground System Development (WBS 9), and Public Outreach (WBS 11) scope and costs, while describing the science and data products. This grass roots estimate draws on *Chandra* actual labor and equipment plus schedule for pre-launch development and “steady-state” operations, with explanations of projected savings and increases down to lower levels of the WBS.

MISSION OPERATIONS DEVELOPMENT
QUESTION 5

Describe the science and operations center for the activity: will an existing center be expected to operate this activity? How many distinct investigations will use the facility? Will there be a guest observer program? Will investigators be funded directly by the activity?

Chandra again provides an excellent model for *Lynx*. The operations concept is based on actual *Chandra* experience. NASA will need to decide whether to assign science and operations responsibilities to the *Chandra* X-ray Center (which is currently planned for continuation through most of the 2020’s and quite possibly well beyond assuming that *Chandra* continues to operate successfully), or to another organization. The *Lynx* baseline is that a single center should have responsibility for both mission and science operations. Based on *Chandra* experience and *Lynx* modeling, it is anticipated that of order 200 distinct investigations recommended by peer review each year, with general (preferred term rather than guest) observers being leads for essentially all of the programs other than calibrations which require only a few percent of the observing time. General investigators would be funded directly by the *Lynx* science and operations center.



MISSION OPERATIONS DEVELOPMENT
QUESTION 6
 Will the activity need and support a data archive?

Lynx will require and support an archive. After 20 years, the *Chandra* archive holds ~37 TB of raw and processed data and data products at each of 2 sites, plus a cloud backup. The *Lynx* data rates are ~100 times those of *Chandra* so the projection is for an archive requirement of 3700 TB after 20 years of *Lynx* operations, which should be easily met in the relevant time-frame.

It is anticipated that many archive researchers will apply for funding from the annual peer review, while others may simply access publicly available data through the archive links. At present, NASA's High Energy Astrophysics Science Archive Research Center (based at GSFC) serves as a secondary archive for publicly released *Chandra* data products and will also provide for longer-term, post-mission archiving of the *Chandra* data and data products. A similar arrangement is envisioned for the *Lynx* archive.

Table 14. Mission Operations and Ground Data Systems Table

Downlink Information	Value / Units
Number of Contacts per Day	3 per day, 1 hour duration each
Downlink Frequency	Ka-band for telemetry: 25.5-27 GHz X-band for status checks: 8.4-8.5 GHz
Telemetry Data Rate(s)	22.2 Mbps
S/C Transmitting Antenna Type(s) and Gain(s)	Ka Phased-array, no gimbals: 26.8 DBi X-band patch antenna: 6 DBi X-band horn: 20 DBi
Spacecraft Transmitter peak power	Ka: 20W X-band: 25W
Downlink Receiving Antenna Gain	DSN 34m Ka: 77.2 DBi X-band: 68.2 DBi
Transmitting Power Amplifier Output	80 W
Uplink Information	Value / Units
Number of Uplinks per Day	3 per day, same contacts as downlinks
Uplink Frequency Band, GHz	X-band: 7.145-7.235 GHz
Telecommand Data Rate	<~1 Mbps
S/C Receiving Antenna Type(s) and Gain(s)	X-band patch antenna: 6 DBi

Note. All requirements shown in this Table are readily achieved with currently available hardware.



PROGRAMMATICS & SCHEDULE QUESTION 1

Provide an organizational chart showing how key members and organizations will work together to implement the program.

The *Lynx* project organization is described in [Lynx Report, §8.2 \(pp.216–217\)](#). Specifically, [Figure 8.1 \(p.217, reproduced below on page page 52\)](#) provides the notional project organization.

Lynx is a Category 1, Risk Class A project as defined in NASA Procedural Requirements NPR7120.5 and NPR8705.4 respectively. As such, the project will be under the decision authority and governance of the NASA Associated Administrator (AA) and the Science Mission Directorate (SMD) AA.

The project organization is consistent with the *Lynx* Work Breakdown Structure (WBS), which is consistent with NASA guidelines. The WBS and project structure take advantage of *Chandra* heritage for organizational and cost comparisons.

Further details, as well as specific roles and responsibilities are excerpted from the [Lynx Report](#) and provided on the pages that follow here.

The *Lynx* project organization reflects that of successfully implemented heritage flagship missions. The notional project structure for *Lynx* (Figure 1 on page page 52) encompasses the roles necessary to deliver and launch the Observatory, provide required levels of technical authority oversight and insight, and ensure overall mission success. This organization is consistent with the project Work Breakdown Structure (WBS) and dictionary summarized in [Lynx Report, §8.5.1](#). Specific mission roles will be established prior to Phase A following the final architecture decision and Mission Concept Review (MCR). Strategic partnerships will take advantage of the existing resources (hardware and facilities) and workforce developed, over many years, for *Chandra*. These partnerships reduce risk through the implementation of lessons learned and significant stored knowledge of *Chandra* development through flight. Additionally, as a Flagship mission, *Lynx* welcomes continued international participation. An Acquisition Strategy Meeting will be conducted early in Phase A to finalize decisions on international agreements, procurements, and partnerships.

The *Lynx* project will be staffed by the lead NASA Center (possibly supported by an external science team) to provide overall management and integration of mission elements, as well as lead project scientist functions.

Specifically:

- WBS 01, Project Management (PM) functions include the management, integration, and direction of *Lynx* project activities, in compliance with Agency policies and procedures. The PM is responsible for programmatic business activities, control of the programmatic baseline, and resource management through rigorous project planning and control processes. The science payload manager for development of the X-ray mirrors and science instruments [the *Lynx* X-ray Microcalorimeter (LXM), High-Definition X-ray Imager (HDXI), and X-ray Grating Spectrometer (XGS)] will directly report to the PM.
- WBS 02, Systems Engineering (SE) functions include the technical design and performance of the mission. The Mission Systems Engineer (MSE) provides independent technical authority for *Lynx*.

Response to **Programmatics & Schedule** Question 1 (*continued*)

- WBS 03, Safety and Mission Assurance (S&MA) functions include independent overview of S&MA activities and complying with S&MA requirements.
- WBS 04, Project Scientist functions include leading the Science Working Group (SWG), ensuring the science content of the project, providing oversight for the technology development activities, and serving as the project interface to the *Lynx* science community.
- WBS 05, X-ray Telescope (XRT) management functions include overall Design, Development, Test, and Evaluation (DDT&E) of the telescope (integrated LMA+OBA+ISIM) and its subsystems, as well as Integration and Test (I&T) and calibration of the telescope. It is assumed that these activities will be contractor-managed.
- WBS 06, Spacecraft Element (SCE) management functions include overall DDT&E of the SCE and its subsystems, as well as I&T of the SCE. It is assumed that these activities will be contractor-managed.
- WBS 07/09, Ground systems and mission operations functions include responsibility for the design, development, integration, test, implementation, and associated physical support equipment of the ground system needed for commanding and operating the Observatory. This includes downlinking, processing, archiving, and distributing telemetry with the engineering and scientific data.
- WBS 08, Launch vehicle services functions include interfacing between the project and launch vehicle provider.
- WBS 10, Observatory I&T functions include management of the overall Observatory I&T program.
- WBS 11, Outreach functions include responsibility for informing the public on *Lynx's* benefits to the community.

Answer continued on next page



Response to **Programmatics & Schedule** Question 1 (continued)

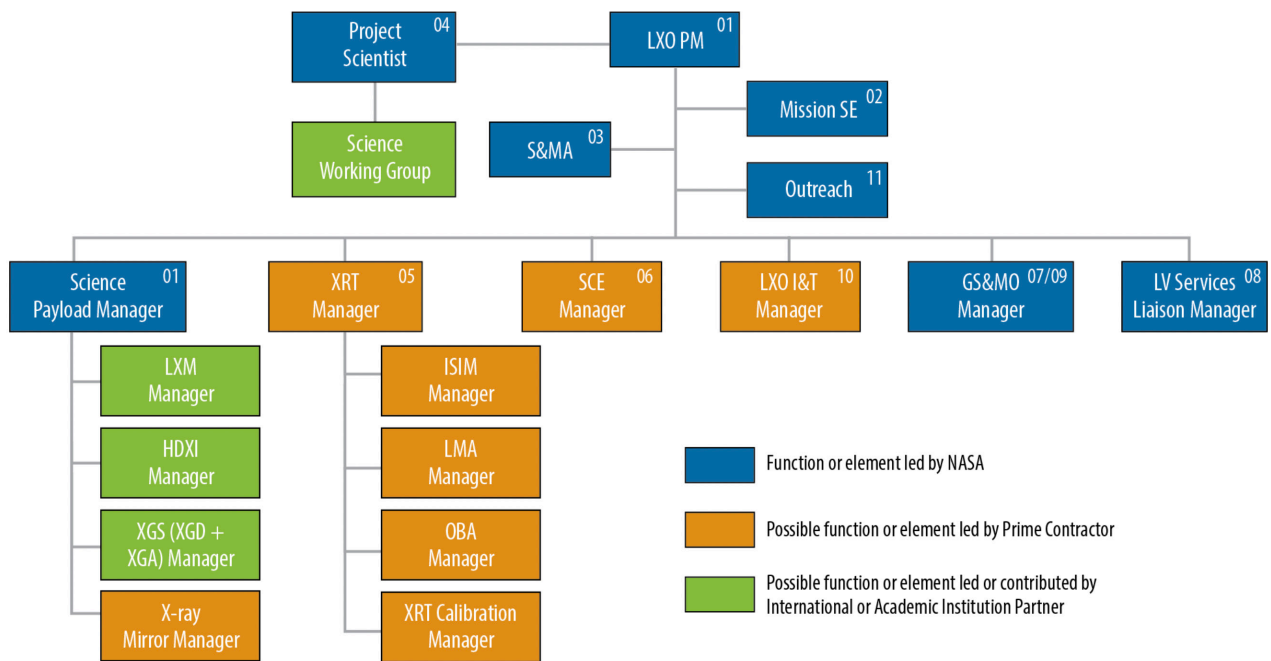

Figure 1. (Figure 8.1 in *Lynx Report*) Notional *Lynx* project organization is consistent with NASA management practices and considers possible partnerships and prime contractor activities. Final organization will be defined following pre-Phase A procurement decisions and Mission Concept Review.

Answer continued on next page



Response to **Programmatics & Schedule** Question 1 (*continued*)

A prime contract is anticipated to be competitively selected for the DDT&E of the SCE, the XRT [including DDT&E of the Integrated Science Instrument Module (ISIM)], and the *Lynx* Mirror Assembly (LMA). The prime contractor will be responsible for overall integration for the Observatory, including systems I&T and launch vehicle liaison activities. The anticipated prime contract roles defined above are similar to the management approach used for *Chandra*.

The *Lynx* project will benefit from potential international and/or academic partnerships. Along with the intention of having a fully open scientific program similar to *Chandra* and *XMM-Newton*, and presumably *Athena*, potential areas of contribution could include instruments, building on existing collaborations, or even a distinct contribution to the spacecraft. The possibility of such contributions is being explored and decisions will be made at the Acquisition Strategy Meeting early in Phase A.

It is assumed that the science instruments will be provided by an academic institution, NASA or other government agency, or by an international partner, and that the X-ray mirrors will be provided by a contractor. Instrument providers will be selected through a NASA-issued Announcement of Opportunity (AO), and the X-ray mirror provider will be selected through a NASA-issued Request for Proposal (RFP). It is also assumed that a *Lynx* Science and Operations Center ([Lynx Report, §6.7](#)) will be responsible for developing the ground system and leading Phase E under the direction of the lead NASA Center. The preliminary sequencing of the AOs and RFP are provided in the project lifecycle schedule, see [Lynx Report, Figure 8.3 \(p.225\)](#).

**PROGRAMMATICS & SCHEDULE
QUESTION 2**
Provide a table and a 5 by 5 risk chart of the top 8 risks to the program. Briefly describe how each of these risks will be mitigated and the impact if they are not.
(Mass, power, schedule, cost, science etc.)

The *Lynx* team identified top project risks, which were defined as those with the potential to change the technical and/or programmatic baseline. The risks are listed in [Lynx Report, Table 8.1 \(p.218, reproduced on next page\)](#) and [Figure 8.2 \(p.219, reproduced on next page\)](#) provides the 5x5 risk ranking per the standard scale for consequence and likelihood, consistent with Goddard Procedural Requirements (GPR) 7120.4D, Risk Management Reporting. The project risks fall under the general categories of technology maturation, manufacturability, and science impact.

In addition to the identified project risks, each major technology under development also carries technology development risks as defined in the individual [Technology Roadmaps](#).

Details on the project risks, mitigation plans impacts and associated risk rankings are excerpted from the report and provided on the pages that follow here.

Answer continued on next page



Response to **Programmatics & Schedule** Question 2 (*continued*)

Table 8.1 from *Lynx Report*: Summary of top *Lynx* project risks.

Risk	Title	L	C	T	S	\$
1	X-ray Mirror Module Assembly and Alignment	3	4		X	X
2	LXM Technical Maturation to TRL 6	3	3	X	X	X
3	X-ray Mirror Segment Industrialization	2	3		X	X
4	LXM Fabrication and Assembly	2	3		X	X
5	X-ray Mirror Technical Maturation to TRL 6	3	2	X	X	X
6	HDXI/XGD Detector Technology Maturation to TRL 6	2	2	X	X	X
7	Calibration Facility Availability	1	3		X	X

L = likelihood of risk occurrence; C = consequence of risk occurrence; T = technical risk; S = schedule risk; \$ = cost risk

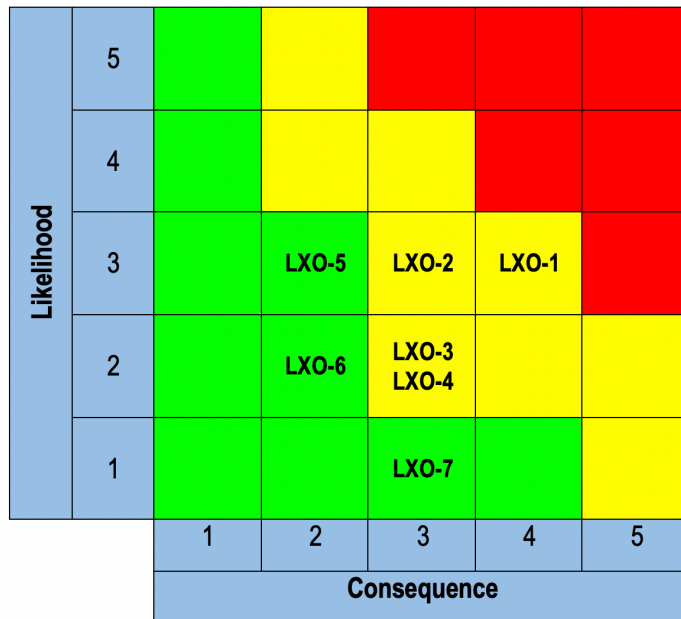

Figure 2. (Figure 8.2 in *Lynx Report*): *Lynx* risk ranking. No red risks identified; all identified risks can be mitigated.

Answer continued on next page

Response to **Programmatics & Schedule** Question 2 (*continued*)

Risk 1 — X-ray Mirror Module Assembly and Alignment: If the ability to demonstrate and scale up the processes from a laboratory environment to the production levels needed to assemble and align the numerous X-ray mirror modules cannot be achieved while maintaining technical requirements, then the project cost and schedule will be impacted.

Mitigation: For each mirror system design under consideration, an early study of mirror segment and module alignment and mounting processes has been initiated as part of the overall [SMO Technology Roadmap](#) and DDT&E schedule. For the Silicon Meta-Shell Optics specifically, recent developments have shown the feasibility of producing a single aligned high-quality mirror segment pair that meets the necessary mirror figure. Further work is needed to prove full-scale feasibility of the necessary processes with requisite quality control to mount and align the many mirror segments into modules needed for flight. This work will take place during technology development. Starting at TRL 4, multiple partially-populated modules will be demonstrated. By TRL 6/PDR, a high-fidelity, qualification-tested, partially populated EM will be developed and will serve as pathfinder for the technology, as well as the manufacturing and assembly processes. For the Silicon Meta-Shell Optics technology, the EM will consist of three meta-shells (outer, middle, inner) with three fully populated modules in each that serve as a testbed for demonstrating technical and assembly processes. Nine months of DDT&E schedule margin have been added to the Silicon Meta-shell Optics delivery to flight unit calibration/verification. This margin includes three months to delivery of the TRL6/PDR demonstration unit to cover issues that arise during technology maturation and an additional six months of margin for issues that arise during the manufacturing and assembly process of the flight unit.

Impact: Increased cost and schedule to meet technical requirements.

L × C: 3 × 4

Risk 2 — LXM Technical Maturation to TRL 6: If the LXM is unable to achieve requisite technology maturation and performance to TRL 6, then the mission science and/or technology development cost and schedule will be compromised.

Mitigation: A detailed [LXM Technology Roadmap](#) that includes cost, schedule, and risk has been developed for the LXM, which is based on extensive experience from previous and planned space-based X-ray microcalorimeters. Technology developments from the *Hitomi* SXS, *Athena* X-ray Integral Field Unit (X-IFU), and X-Ray Imaging and Spectroscopy Mission (*XRISM*) Resolve X-ray microcalorimeter instruments will be leveraged as applicable for the LXM ([Lynx Report §6.3.4](#)). Individuals supporting *Athena* X-IFU development also support LXM development from pre-Phase A onward, and those supporting the *XRISM* Resolve instrument will support the LXM from Phase A onward. The large-scale fabrication of detectors is low risk since detectors have already been produced with scale and performance close to requirements, utilizing proven processes with high yield and reliability. For the read-out, the main risk is the number of read-out channels needed and, therefore, how much cooling power is required (and thus spacecraft resources such as power), rather than whether or not it will reach TRL 6. The LXM read-out uses microwave Superconducting Quantum Interference Device (SQUID) resonators that are not difficult to fabricate in comparison to components under development for missions operating at longer wavelength. (For LXM, relatively few resonators per feedline are needed and thus reso-

Answer continued on next page

Response to **Programmatics & Schedule** Question 2 (*continued*)

nance frequency accuracy is not critical). The LXM DRM design requires the read-out of 7,600 sensors—not a major scale-up from the number of sensors in the *Athena* X-IFU—and naturally leads to a focal plane assembly that is 4 inches in diameter at 50 mK (similar to the X-IFU) and with relatively standard optical blocking filter sizes. Several industry studies have been initiated to investigate the LXM cryogenic design to identify the solution space (mass, volume, and complexity versus cost) for this already mature subsystem. Two Cooperative Agreement Notices (CANs) were carried out during the *Lynx* study, specifically to investigate the maturity of these systems and to consider their maturity as part of the LXM system. Periodic reviews will be conducted as needed to ensure requisite development milestones are met and that conservative cost and schedule reserves have been applied. As part of the detailed [LXM Technology Roadmap](#), a high-fidelity, full-assembly EM will be developed to serve as a pathfinder for Observatory assembly, integration, and test. Six months of DDT&E schedule margin to TRL 6 have been included in the LXM development schedule to cover issues that may arise during technology maturation.

Impact: Reduced science capability or increased cost and schedule for technology development.

L × C: 3 × 3

Risk 3 — X-ray Mirror Segment Industrialization: If the manufacturing process used to fabricate mirror segments cannot be scaled to the required industrial-scale production levels while still meeting the technical requirements, then the project cost and schedule will be impacted.

Mitigation: For each mirror system design under consideration, an early study of manufacturability and production of the mirror elements has been initiated through industry partnerships and as part of overall technology development considerations. For the Silicon Meta-shell Optics specifically, recent developments have shown that producing multiple high-quality segments that meet the necessary mirror figure is feasible within the *Lynx* program cost and schedule. Further work is needed to prove full-scale manufacturing feasibility with requisite quality control to produce the quantity of segments required for flight, as described in [Lynx Report, §8.5.2.1 \(pp.232–235\)](#). An advantage of the Silicon Meta-shell Optics design is the nearly identical sizes and shapes of mirror segments regardless of location within the X-ray mirror assembly, and realization of cost and schedule savings via the utilization of several parallel processes in the manufacturing of these elements. Optimization of the manufacturing process (number of parallel machine lines, polishing lines, coating lines, etc.) will lead to a reduction in cost and schedule once the process steps have been defined and proven to yield segments and modules meeting project requirements. A high fidelity, partially populated EM will be developed as part of the TRL 6/PDR demonstration to serve as pathfinder for the technology and manufacturing processes. For Silicon Meta-shell Optics, an assumed 10% for spares has been included in the cost model to account for quality and other issues during the manufacturing process. Furthermore, via industry partnership, a queuing theory-based model has been developed for the production time and cost of the LMA to determine the most efficient cost and schedule path through the manufacturing process, including but not limited to identification of gating process(es) and the number of parallel manufacturing lines necessary to prevent pileup. Finally, if schedule and cost challenges arise, mirror pairs can

Answer continued on next page

Response to **Programmatic & Schedule** Question 2 (*continued*)

be eliminated from the design for up to a 50% reduction in effective area as discussed in [Lynx Report](#), §9 (pp.258–267). In this case, mass dummies would replace the eliminated mirror pairs, thus saving the time and cost for mirror polishing, coating and ion beam figuring. This option would not decimate the *Lynx* science program, but would necessitate longer exposure times. Nine months of DDT&E schedule margin have been added to the Silicon Meta-shell Optics delivery to flight unit calibration/verification. This margin includes three months to delivery of the TRL 6/PDR demonstration unit to cover issues that arise during technology maturation, and an additional six months of margin for issues that arise during the manufacturing and assembly process of the flight unit.

Impact: Increased cost and schedule to meet technical requirements.

L × C: 2 × 3

Risk 4 — LXM Instrument Fabrication and Assembly: If the LXM and its subsystems and components cannot be fabricated, assembled, tested, and integrated within the projected timescale, then the critical path project schedule margin will be eroded at increased project life-cycle cost.

Mitigation: The DDT&E schedule for the LXM is based on the [LXM Technology Roadmap](#) and leverages the DDT&E plan from the *Athena* X-IFU, as applicable. A full, high-fidelity LXM EM is planned prior to Critical Design Review (CDR) to serve as a pathfinder for the manufacturing and assembly processes. A team of scientists and engineers at GSFC possess substantial experience in the development of instrumentation of this type. This team developed the detectors, focal plane assembly, filters, Adiabatic Demagnetization Refrigerator (ADRs), etc. for *Astro-E*, *Astro-E2*, and *Hitomi*; have applicable experience for I&T, calibration, etc.; and a proven record of having developed space-flight hardware on schedule. This GSFC team is currently focused on delivering similar hardware for the Resolve instrument on *XRISM*, which is scheduled to launch in 2022. The team will likely be available for the full LXM development life cycle. In an almost ideal time-scale, they will be available to complement the separate technology development team currently focused on developing TES detectors and readout for the *Athena* X-IFU at the start of Phase-A. The gradual ramp-down of *Athena* X-IFU activities will likely fit well with the ramp up of LXM detector development work. DDT&E schedule margin of four months plus an additional five months of critical path reserve has been added to the project schedule for LXM delivery to ISIM I&T to account for issues that may arise during the fabrication and assembly process.

Impact: Critical path schedule duration and increased project cost.

L × C: 2 × 3

Risk 5 — X-ray Mirror Technical Maturation to TRL 6: If the X-ray mirrors are unable to achieve requisite technology maturation and performance, then the mission science and/or technology development cost and schedule will be compromised.

Mitigation: [Technology Roadmaps](#) have been developed for the three different *Lynx*-feasible, actively funded X-ray mirror technologies. Each technology will receive continued funding during pre-Phase A development and a final selection (based on technology maturation and proximity

Answer continued on next page

Response to **Programmatics & Schedule** Question 2 (*continued*)

to reaching TRL 5 by the start of Phase A) will be made by the time of the *Lynx* Mission Concept Review (MCR) to ensure that the most mature and capable technology is selected for the mission. Carrying the three technology developments in parallel and making periodic schedule and technology advancement-driven downselect decisions provides risk mitigation among the candidates and optimization of science return. Each of these identifies a set of unique risks and mitigation plans. The Silicon Meta-shell Optics technology chosen for the DRM has already validated the process of mirror segment fabrication and alignment through X-ray testing. Conservative cost and schedule reserves on the Silicon Meta-shell Optics technology have been applied, and periodic reviews will be carried out as needed to ensure that developmental goals are met. Furthermore, a high-fidelity, partially-populated EM will be developed as part of the TRL 6/PDR demonstration to serve as a pathfinder for the technology and manufacturing processes. Three months of DDT&E schedule margin to TRL 6 has been added to the mirror development schedule to account for issues that may arise during technology maturation.

Impact: Reduced science capability or increased cost and schedule for technology development.
L × C: 3 × 2

Risk 6 — HDXI/X-ray Grating Detector Technology Maturation to TRL 6: If the HDXI and X-ray Grating Detector (XGD) are unable to achieve requisite detector technology maturation and performance, then the mission science and/or technology development cost and schedule will be compromised.

Mitigation: An [HDXI Technology Roadmap](#) has been developed. Because XGD requirements are met with the same sensors as those for HDXI, the [HDXI Technology Roadmap](#) is sufficient for both. Though the hybrid CMOS-sensor technology has been selected for the DRM, there are at least two other sensor technologies of similar maturity that can meet *Lynx* requirements. Each of these sensor technologies (hybrid CMOS, advanced Charge-Coupled Device (CCD), and monolithic CMOS) have demonstrated proof-of-concept and are assessed at TRL 3. Each technology will be developed until a predefined downselect milestone in 2023, at which point the two most advanced technologies will proceed with development to TRL 4. These two selected sensor technologies will be funded to achieve TRL 4 by the start of *Lynx* project Phase A. A single sensor technology will be selected for TRL 5. Downselect decisions will be based on the cost and schedule to meet remaining TRL milestones and ability to meet *Lynx* performance requirements. Carrying the three technology developments in parallel and making periodic, schedule-driven downselect decisions mitigates risk among the candidates. If none of the advanced technologies makes the requisite progress, the use of existing CCD technology may be utilized, though with reduced capability. Five months of DDT&E schedule margin to TRL 6 have been added to the HDXI and XGD development schedules to cover issues that may arise during technology maturation.

Impact: Reduced science capability or increased cost and schedule for technology development.
L × C: 2 × 2

Risk 7 — Calibration Facility Availability: If NASA Marshall Space Flight Center's (MSFC's) X-ray and Cryogenic Facility (XRCF) is chosen as the calibration facility for the *Athena* mission, and if the *Athena* calibration activity is significantly delayed, the *Lynx* schedule will be impacted.

Answer continued on next page

Response to **Programmatics & Schedule** Question 2 (*continued*)

Mitigation: Currently, the *Athena* mission's notional schedule indicates that the flight unit calibration activities will take place from approximately mid-FY28 to around mid-FY29. The current *Lynx* project schedule has rehearsal and flight unit calibration activities taking place around mid-FY31 to late FY32. To impact the *Lynx* critical path, the *Athena* calibration activity would need to slip by approximately 2.5 years. This issue is currently considered a “watch” item.

Impact: Schedule duration and increased project cost.
L x C: 1 x 3

PROGRAMMATICS & SCHEDULE
QUESTION 3

Provide an overall (Phase A through Phase F) schedule highlighting key design reviews, the critical path and the development time for delivery required for each instrument, the spacecraft, development of ground and mission/science operations etc. Include critical on-orbit events such as maneuvers, instrument deployments, etc.

The project lifecycle schedule is provided in [Lynx Report, Figure 8.3 \(p.225, reproduced on next page\)](#). The schedule was developed utilizing Government Accountability Office (GAO) Best Practices for Project Schedules, consistent with pre-Phase A project maturity. Schedule planning included identification of all milestones and KDPs consistent with NPR 7120.5.

The critical path was calculated based on the longest duration of activities through the project schedule. The *Lynx* critical path runs through the LXM DDT&E, and through ISIM, XRT, Observatory and launch vehicle I&T activities. The X-ray mirror development path through DDT&E only lags the LXM DDT&E path by ~1 month in this schedule. Nineteen months of schedule reserves were added to the critical path activities, consistent with guidance from MSFC 7102.1, Table 17-3, Standard Schedule Margin for Programs/Projects. In addition to the critical path reserves, margin has been added to the X-ray mirrors and science instrument schedules to account for uncertainties associated with technology development, DDT&E, and key integration activities. Reserves have also been added to the on-ground calibration, LMA, and the ISIM I&T to account for uncertainties associated with these activities. Critical path and schedule reserves are summarized in [Lynx Report, Table 8.3 \(reproduced below\)](#).

The *Lynx* launch to orbit timeline is provided in [Lynx Report, Figure 6.28 \(p.139, reproduced below\)](#). It provides the critical maneuvers to get to the SE-L2 orbit in 104 days based on mission analysis and the calculated Δ -V budget. During the time to reach orbit, the spacecraft and telescope systems are powered on, allowed to outgas, and undergo system checks and initial calibration.

The *Lynx* concept of operations is described in [Lynx Report, §6.7 \(pp.169–178\)](#). It provides further details of the launch to orbit activities, and descriptions of all aspects of on-orbit operations. See next pages for lifecycle schedule and launch to orbit timeline.

Answer continued on next page

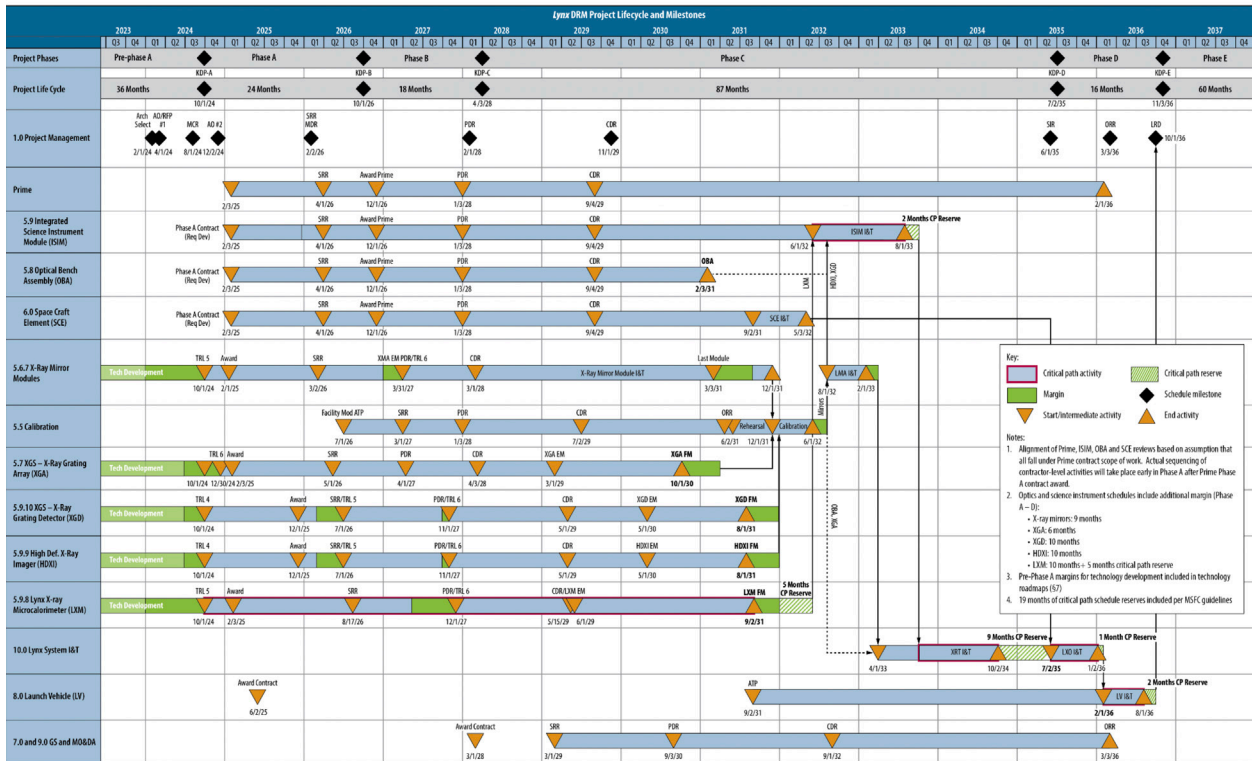

Figure 3 (Figure 8.3 in *Lynx Report*): *Lynx* project life-cycle schedule

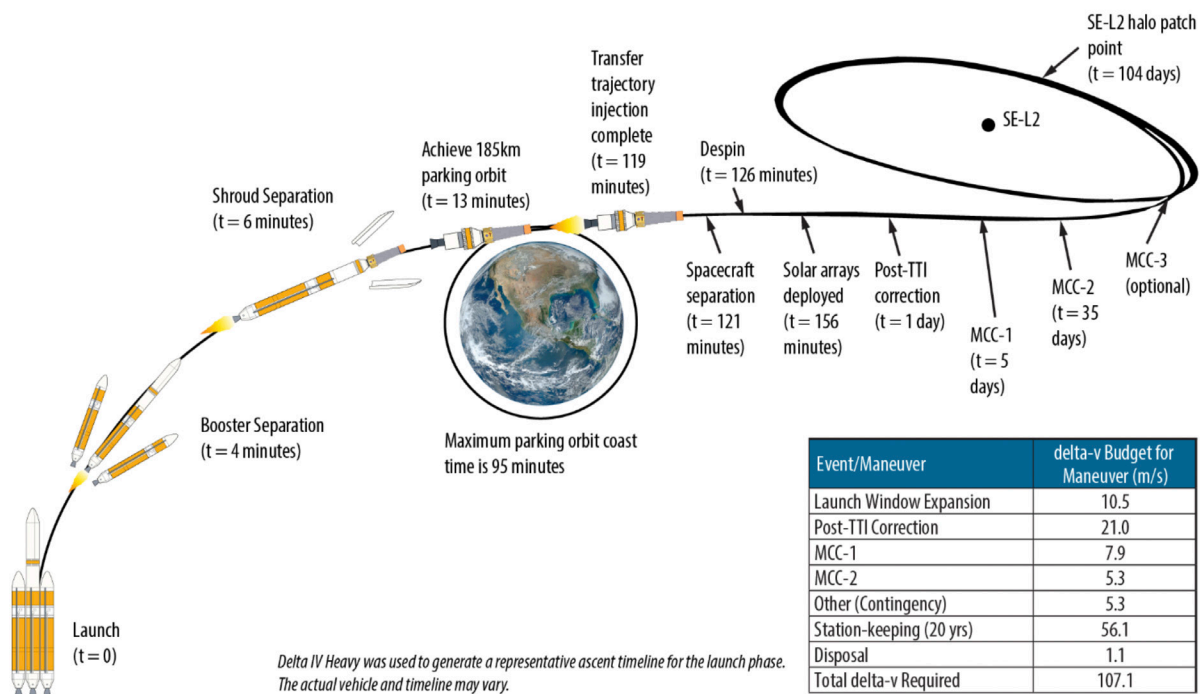

Figure 4 (Figure 6.28 in *Lynx Report*): *Lynx* launch-to-orbit timeline



PROGRAMMATICS & SCHEDULE
QUESTION 4

Fill out the Key Phase Duration table indicating the length of time required (months) for: each Phase (A through F), ATP to PDR, ATP to CDR, and other key metrics for schedule analysis (ATP to instrument delivery, spacecraft delivery, observatory delivery and launch).

Table 15 (following Table 8.3 in [Lynx Report](#)): Key Phase Duration Table

Project Phase	Duration (months)
Phase A – Conceptual Design	24
Phase B – Preliminary Design	18
Phase C – Detailed Design	87
Phase D – Integration & Test	16
Phase E – Primary Mission Operations	60
Phase F – Extended Mission Operations	Not specified; primary mission lifetime of 5 years, extendable to 20 with on-board consumables
Start of Phase B to PDR	16
Start of Phase B to CDR	37
Start of Phase B to Delivery of X-ray Mirror Assembly to Calibration*	62
Start of Phase B to Delivery of LXM to ISIM I&T*	68
Start of Phase B to Delivery of HDXI to Calibration*	63
Start of Phase B to Delivery of XGD to Calibration*	63
Start of Phase B to Delivery of XGA to Calibration*	54
Start of Phase B to Delivery of Spacecraft	67
Start of Phase B to Delivery of Observatory	112
System Level Integration & Test**	15
Project Total Funded Schedule Reserve***	68 (Phase A - D)
Total Development Time Phase B - D	121

*note that “delivery” of optics and instruments for *Lynx* is assumed as the delivery to the next level of integration

**note that “System Level” I&T for *Lynx* is defined as integration of the Observatory (telescope + spacecraft) to the Launch Vehicle.

***note that there is a total of 49 months of costed schedule reserves on non-critical path activities based on project development assessments, and 19 months of critical path reserves, consistent with MSFC guidelines. The critical path, defined as the longest path of linked activities, is LXM DDT&E to ISIM I&T to XRT I&T to LXO I&T to LV I&T.



Response to **Programmatics & Schedule** Question 4 (continued)

A more detailed table of key phase durations is given in [Lynx Report, Table 8.3 \(p.227, reproduced below\)](#). It includes the basis of estimate for each phase as well as identification of costed schedule margin and critical path reserves for key activities.

Table 8.3. Key phase duration table.

Project Phase	Duration (months)	Comments
Pre-Phase A (Technology Development)	36	Pre-Phase A duration based on technology development schedules and assumed funding levels (comparable to <i>WFIRST</i>)
Phase A (Conceptual Design): KDP-A to KDP-B	24	Phase A duration based on technology development schedules and funding (comparable to <i>WFIRST</i> levels).
Phase B (Preliminary Design): KDP-B to KDP-C	18	Phase B duration based on assumed technology development funding and all technologies reaching TRL 6 by PDR
Phase C (Detailed Design): (KDP-C to KDP-D)	87	Phase C includes development of X-ray mirrors (and integration into LMA) and 3 science instruments, mirror and instrument on-ground calibration, ISIM I&T, and XRT I&T. X-ray mirror development assumes multiple parallel manufacturing lines to be optimized during Phase A. LXM schedule comparable to <i>Athena</i> X-IFU. <i>Chandra</i> Phase C duration similar except for no analogous LXM, and <i>Chandra</i> SIM integration took place during Observatory I&T in Phase D. <i>WFIRST</i> Phase C shorter due to less complex design (2 science instruments and no ISIM)
Phase D (I&T): KDP-D to KDP-E	16	Phase D includes integration of XRT and SCE to become the LXO. <i>Chandra</i> Phase D also included integration of SIM during Observatory I&T. <i>Lynx</i> assumes ISIM integration during XRT I&T in Phase C
Phase E (Primary Mission Ops): KDP-E to KDP-F	60	<i>Lynx</i> planned operational lifetime is 5 years, extendable to 20 years with on-board consumables
Start of Phase A to SRR	16	
Start of Phase B to PDR	16	
Start of Phase C to CDR	19	
Start of Phase C to SIR	86	
Start of Phase D to LRD	15	
Phase B to X-ray Mirror Delivery to Calibration	62 (53+9)	<i>Lynx</i> mirror DDT&E includes additional 9 months of schedule margin
Phase B to LXM Delivery to ISIM I&T	68 (53+10+5)	LXM DDT&E includes additional 10 months of schedule margin and 5 months of critical path reserve
Calibration (Flight Unit)	8 (6+2)	On-ground calibration similar to <i>Chandra</i> with exception of additional science instrument (LXM EM); Schedule includes additional 2 months of margin
LMA I&T	8 (6 + 2)	LMA I&T involves integration of the X-ray mirror module assembly, pre- and post-collimators, contamination doors, and other structures into the barrel structure; Schedule includes 2 months of margin
ISIM I&T	16 (14+2)	ISIM I&T is more complex than <i>Chandra</i> SIM actual due to mechanisms and additional instrument; Schedule includes 2 months of critical path reserve
Telescope I&T	27 (18+9)	XRT I&T involves integration of LMA, XGA, OBA, and ISIM; Schedule includes 9 months of critical path reserve
SCE I&T	8	<i>Lynx</i> SCE comparable to <i>Chandra</i> actual; No additional margin included
Observatory I&T	7 (6+1)	<i>Lynx</i> Observatory I&T comparable to <i>Chandra</i> actual; Schedule includes 1 month critical path reserve
Launch Site Activities	8 (6+2)	<i>Lynx</i> LV Integration comparable to <i>Chandra</i> actual; Schedule includes 2 months critical path reserve



**PROGRAMMATICS & SCHEDULE
QUESTION 5**
Fill out the Key Event Dates table indicating the dates (month/year)
for the key development and operations milestones

Table 16 (following [Table 8.2 in Lynx Report](#)): Key Event Dates Table

Project Phase	Milestone Date
Start of Phase A	10/2024
Start of Phase B	10/2026
Preliminary Design Review (PDR)	02/2028
Critical Design Review (CDR)	11/2029
Delivery of LXM Flight Unit to ISIM I&T	06/2032
Delivery of X-ray Mirror Modules to LMA I&T	08/2032
Delivery of XGA to XRT I&T	08/2032
Delivery of XGD to ISIM I&T	08/2032
Delivery of HDXI to ISIM I&T	08/2032
System Integration Review	06/2035
Pre-Ship Review (PSR)	Not specified; assumed that Observatory PSR is ~3 months prior to start of LV I&T (11/2035)
Launch Readiness Date (LRD)	10/2036
End of Mission - Primary (EoM-P)	11/2041
End of Mission - Extended (EoM-E)	Not specified; primary mission life of 5 years is extendable to 20 years with on-board consumables.

A more detailed table of key event dates is included in [Lynx Report, Table 8.2 \(p.224, reproduced below\)](#). It includes additional milestones not included in the RFI table.

Response to **Programmatics & Schedule** Question 5 (*continued*)**Table 8.2** from [Lynx Report](#): Key Event Dates

Project Milestone	Approximate Milestone Date
Technology Development / Start of Pre-Phase A	10/2021
Architecture Decision	2/2024
MCR	8/2024
KDP-A / Start of Phase A	10/2024
SRR/MDR	2/2026
KDP-B / Start of Phase B	10/2026
PDR	2/2028
KDP-C / Start of Phase C	4/2028
CDR	11/2029
Start of X-ray Mirror Module, XGD & HDXI Flight Unit Calibration	12/2031
Delivery of LXM Flight Unit to ISIM I&T	6/2032
Delivery of X-ray Mirror Modules to LMA I&T	8/2032
Delivery of LMA to XRT I&T	4/2033
Delivery of ISIM to XRT I&T	10/2033
SIR	6/2035
KDP-D / Start of Phase D	7/2035
ORR	3/2036
LRD	10/2036
KDP-E / Start of Phase E	11/2036
End of Primary Mission	11/2041



**PROGRAMMATICS & SCHEDULE
QUESTION 6**
Provide an estimate of schedule reserves required during Phases A – D.

Total reserves for development and integration are included and shown in the project schedule, in [Lynx Report, Figure 8.3 \(p.225, reproduced on page 60\)](#). Reserves are included for all major activities based on development plans and risk assessments. Critical path reserves are included per MSFC guidelines. The critical path is based on the longest linked set of activities through the schedule, which goes through LXM DDT&E, ISIM I&T, XRT I&T, LXO I&T, and LV I&T.

The table below provides the non-critical path and critical path reserves by phase for each development and integration activity. There is a total of 49 months of non-critical path reserves and 19 months of critical path reserves, for a total of 68 months of costed reserves in phases A – D for *Lynx*.

Table 17 Non-Critical and Critical Path Reserves

Activity	Costed Schedule Reserves (Months)										
	Phase A		Phase B		Phase C		Phase D		Totals		
	Non-Critical Path	Critical Path	Non-Critical Path	Critical Path	Non-Critical Path	Critical Path	Non-Critical Path	Critical Path	Non-Critical Path	Critical Path	All
X-ray Mirror Module DDT&E			3		6				9		9
XGA DDT&E					6				6		6
XGD DDT&E	4		1		5				10		10
HDXI DDT&E	4		1		5				10		10
LXM DDT&E			6		4	5			10	5	15
Calibration					2				2		2
ISIM I&T						2				2	2
LMA I&T					2				2		2
XRT I&T						9				9	9
LXO I&T								1		1	1
LV I&T								2		2	2
Totals	8		11		30	16		3	49	19	68



PROGRAMMATICS & SCHEDULE
QUESTION 7

Provide a description of any foreign contributions and their extent

Primary reference: [Lynx Report](#), §8.5.4 (p. 256).

No foreign contributions were included in the *Lynx* study. However, the *Lynx* team welcomes international participation. Potential areas of contribution could include instruments, building on existing collaborations related to *Athena* and *XRISM*, as well as other previous X-ray missions. Other potential areas could involve a distinct contribution to the spacecraft and calibration support. Specific cost contributions will be sought out and defined more formally during pre-Phase A.

COST
QUESTION 1

Provide FTE estimates and cost by year/Phase for science personnel.

The *Lynx* team developed a detailed parametric estimate with multiple models for all elements, with in-family comparisons at the subsystem level and subject matter expert inputs at the component level for all elements, as described in [Lynx Report](#), §8.5 (pp. 228–256). The parametric estimate was validated using multiple, separately conducted methodologies including a comparison to escalated *Chandra* actuals, a grassroots estimate which included costs for all WBS level 2 elements and some WBS level 3 elements, an independent cost evaluation (ICE), and a contracted cost and technical evaluation (CATE). All of the validation estimates yielded favorable comparisons, with the overall conclusion that the lifecycle parametric estimate is reasonable and consistent with pre-Phase A / pre-formulation maturity. The parametric estimate, which is the primary cost estimate for *Lynx* given its pre-formulation level of maturity, does not specifically provide FTE levels. Portions of the grassroots estimate, specifically those for prime contractor efforts, operations, and science instruments included estimated manpower. These details are included in the non-public [Cost Book](#). A true bottoms-up cost assessment with FTE estimates will be developed in the late pre-Phase A / early Phase A timeframe.

COST
QUESTION 2

If a foreign agency is assumed to be a partner or a major contributor, provide an estimate by year and Phase for the breakdown between NASA and foreign contributions.
This should be separate, but consistent with Total Mission Cost Funding Table.

Primary reference: [Lynx Report](#), §8.5.4 (p. 256).

No foreign contributions were included in the *Lynx* study, but see answer to Programmatiks & Schedule, Question 7 at the top of this page for further discussion about potential areas of foreign contribution.



COST QUESTION 3

Provide a description and cost of what will be performed during Pre-Phase A and Phase A by year. Also include total length of Phase A in months and total Pre-Phase A and Phase A estimated costs.

The *Lynx* pre-Phase A activities are assumed to begin with the start of directed funding in ~10/2021, and end with the start of Phase A in ~10/2024 for a total of 36 months of activity.

Prior to the start of directed funding, all of the technologies will continue receiving funding via existing sources. All of the *Lynx* optics and instrument technologies, summarized in [Lynx Report](#), §7 (pp. 182–214) and detailed in individual [Technology Roadmaps](#), are actively funded, with rapid progress being made in all of the DRM technologies.

During the 36 months of pre-Phase A directed funding, the primary focus will be the development of the *Lynx* optics and instrument technologies, along with additional refinements to the overall mission concept and architecture. The *Lynx* team assumes continued development of all of the technologies through the pre-Phase A timeframe, with down-selects made based on maturation progress, ability to meet TRL milestones and *Lynx* technical and performance requirements. Carrying multiple, feasible technologies, with periodic down-select decisions in the pre-Phase A timeframe lowers the overall project risk by allowing the maturation and selection of the most likely technologies able to meet *Lynx* requirements.

As described in the [HDXI Technology Roadmap](#), three separate sensor technologies are currently under development for the HDXI and XGD. An intermediate sensor down-select will take place by ~7/2023, and the final down-select will take place by the start of Phase A, again based on maturation advancement and ability to meet *Lynx* requirements. The selected sensor technology is expected to be at TRL4 by the start of Phase A. The challenges to developing the HDXI and XGD are primarily confined to achieving TRL4 performance. Each of the three sensor technologies have similar development schedules and budgets, driven by their similar fabrication protocols. Each technology progresses through an iterative cycle of development, which takes ~9 months to complete. During the pre-Phase A timeframe, all 3 sets of sensors will be fabricated and tested twice to characterize their performance prior to the intermediate downselect. Then the remaining two sensors will be fabricated and tested for the final characterization and downselect to a single sensor. Once these fundamental capabilities have been demonstrated, subsequent development efforts focus on the assembly and testing of larger sensor/ASIC arrays with higher fidelity testing with respect to flight conditions. These are considered essentially engineering activities and advancement to TRL 5 and TRL 6 is expected to be straightforward.

An integrated technology development schedule, providing the primary activities and milestones to mature the *Lynx* DRM technologies from current state of the art through TRL6, and the anticipated dates to reach requisite TRL milestones is provided in [Lynx Report](#), Figure 7.1 (p. 186, reproduced on page 69).

A final technology review will take place approximately 12 months prior to the start of Phase A to downselect to the individual optics and instrument technologies most ready to meet *Lynx* technical and programmatic requirements.

A final architecture selection decision will be made ~2/2024 for the Observatory design. Following this decision, an announcement of opportunity (AO) for the LXM and XGA science instruments and request for proposals (RFP) for the optics contractor and a prime contractor will be released in ~4/2024. Note that



the AO for the HDXI and XGD instruments will be released in ~12/2024, consistent with technology development plans, and as described above. It is assumed that a single Prime Contractor will be responsible for the DDT&E of the Integrated Science Instrument Module (ISIM), Optical Bench Assembly (OBA), and Spacecraft Element (SCE), as well as Integration and Test (I&T) of the *Lynx* Mirror Assembly (LMA), the telescope, and the Observatory. The Phase A contract for the prime contractor will enable the development of system requirements, as well as detailed schedules and sequencing of contractor-led elements. The remainder of the prime development contract will be negotiated and awarded in Phase B. The Mission Concept Review is planned ~8/2024, followed by the start of Phase A. This approach for contracting is consistent with other major NASA developments, and is assumed for *Lynx*, however, the final acquisition strategy will be defined at the ASM in early Phase A.

During Phase A, technology development (WBS 4) will continue along with project management (WBS 1), systems engineering (WBS 2) and safety and mission assurance (WBS 3) activities necessary for management, oversight, risk mitigation, and requirements development efforts. Prime contractor support is also assumed for development of system requirements. Other Phase A activities include the initiation of calibration facility modifications (assumed MSFC's XRCF), and selection of a launch vehicle provider to enable close coordination of critical design interfaces between the Observatory elements and launch vehicle. Phase A will culminate in the system-level Systems Requirements Review (SRR) followed by a “season” of sub-system SRRs, allowing for the flow down of top-level requirements from the system to the sub-systems. Phase A is expected to start ~10/2024 and end ~10/2026, for a total of 24 months.

Technology development costs for pre-Phase A through TRL 6 were provided by each technology developer and included in the (non-public) [Technology Roadmaps](#). For consistency across all of the [Technology Roadmaps](#), the *Lynx* technology teams were provided with pre-Phase A and Phase A schedule milestones, as well as the requirement to have all technologies at TRL5 by the start of Phase A and TRL 6 by the mission PDR. Given those milestones, the technologists developed the detailed plans to meet the requirements and grassroots costs for achieving them. The integrated cost estimates compare favorably against the *WFIRST* pre-Phase A technology development funding actuals. Although *Lynx* technology development requirements are necessarily different than those of *WFIRST*, this comparison provides a sound sanity check assuming future funding levels will not change remarkably. The technology development and DRM DDT&E plans were then iterated to ensure integration with the Phase A – E project lifecycle schedule. The Phase A costs were estimated via parametric analysis, using 5% of the DDT&E and first flight unit total.

A summary of the pre-Phase A and Phase A costs in \$RY(M) is given in a table below. The \$FY20 costs are provided in the cost tables included in response to Question 4.

Technology	Pre-Phase A (RY\$)			Phase A (RY\$)	
	FY22	FY23	FY24	FY25	FY26
Optics	12.68	15.2	17.83	21.74	30.55
HDXI	13.1	11.29	14.26	11.44	11.75
XGA	2.43	2.5	2.56	2.86	2.94
LXM	11.1	11.72	12.15	16.71	18.09
Other	14.16	12.27	20.95	19.91	13.39
Total	53.48	52.97	67.76	72.66	76.72

*Used 2019 NASA New Start Inflation Index for relative to FY20



Figure 5 (Figure 7.1 in *Lynx Report*): Development Schedule to mature four *Lynx* enabling technologies to TRL6 by mission PDR

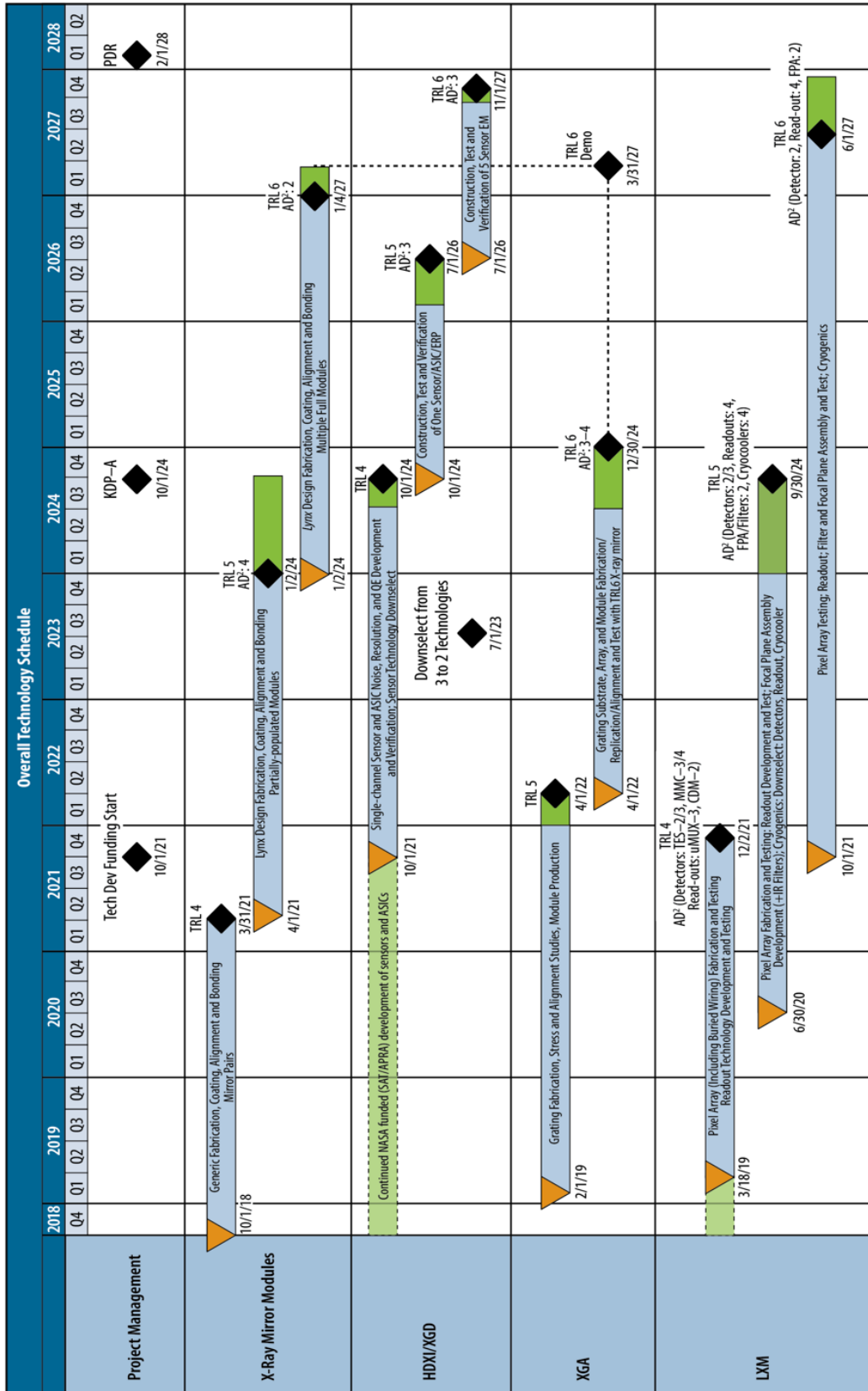

**C O S T
Q U E S T I O N 4**

Please fill out the Mission Cost Funding Profile table assuming that the mission is totally funded by NASA and all significant work is performed in the US.

Primary reference: [Cost Book](#)

See next pages for the pre-Phase A through end of Phase E mission costs for *Lynx* in \$FY20(M) and \$RY(M).

Notes for cost tables:

1. Pre-Phase A estimates developed via grassroots assessments and documented in individual **(non-public) Technology Roadmaps**
2. Phase A estimate developed via parametric analysis
3. Spending profile assumes 60% expended in 50% of time, consistent with NASA standards
4. Fee: 0% on science instruments, 10% on LMA and spacecraft
5. Reserves: 30% on total Phase B – D costs, exclusive of launch vehicle and fee
6. Launch vehicle cost is HQ pass-through for Heavy Lift vehicle in 2030's
7. LXM cost is pass-through from GSFC Instrument Design Lab design and cost assessment
8. MSI&T included in WBS10
9. MO&DA included in WBS7 and WBS9



LYNX MISSION COST ESTIMATE (RY\$ M)

WBS	Lynx WBS Elements	RFI Elements	Phase A - D												Phase E and Total							
			Pre-Phase A			Phase A			Phase B			Phase C			Phase D			Phase E				
			FY22	FY23	FY24	FY25	FY26	FY27	FY28	FY29	FY30	FY31	FY32	FY33	FY34	FY35	FY36	FY37	FY38	FY39	FY40	FY41
			(10/21 - 10/24)	(10/24 - 10/26)	(10/26 - 4/28)	(4/28 - 7/35)	(7/35 - 11/36)	(11/36 - 11/41)					(11/36 - 11/41)					(RYSM)				
			36 months	24 months	18 months	87 months	16 months	60 months					60 months									
01	Project Management	Other		2.74	6.56	6.30	11.54	14.08	15.22	15.28	14.41	12.66	10.07	6.66	2.41							117.93
02	Systems Engineering	Other		2.74	6.56	11.87	21.76	26.54	28.69	28.81	27.16	23.86	18.99	12.55	4.55							214.08
03	Safety & Mission Assurance	Other		1.37	3.28	3.99	7.31	8.92	9.64	9.68	9.12	8.02	6.38	4.22	1.53							73.46
04	Science & Technology	Science	53.48	52.97	67.76	48.25	115.53	8.19	15.01	18.32	19.80	19.88	18.74	16.47	8.66	3.14						305.10
05	X-ray Telescope (XRT)	Other		0.00	0.00	181.46	332.55	405.72	438.53	440.32	415.11	364.80	290.28	191.90	69.56							3,130.23
05.01	XRT Management	Other				1.45	2.66	3.24	3.50	3.52	3.32	2.91	2.32	1.53	0.56							25.01
05.02	XRT Systems Engineering	Other				2.73	5.01	6.11	6.60	6.63	6.25	5.49	4.37	2.89	1.05							47.13
05.03	XRT S&MA	Other				0.92	1.68	2.05	2.22	2.23	2.10	1.85	1.47	0.97	0.35							15.84
05.04	XRT Integration & Test	Other				2.77	5.08	6.20	6.70	6.72	6.34	5.57	4.43	2.93	1.06							47.80
05.05	XRT Calibration	Other				2.05	3.76	4.58	4.95	4.97	4.69	4.12	3.28	2.17	0.79							35.36
05.06	Lynx Mirror Assy. (LMA)	Instrument A				80.53	147.58	180.05	194.61	195.41	184.21	161.89	128.82	85.16	30.87							1,389.13
05.07	X-ray Grating Spectrometer (XGS) Grating Array (XGA)	Instrument B				4.86	8.91	10.87	11.75	11.80	11.12	9.78	7.78	5.14	1.86							83.87
05.08	Optical Bench Assy. (OBA)	Other				10.87	19.92	24.30	26.27	26.38	24.87	21.85	17.39	11.50	4.17							187.52
05.09	Integrated Science Instrument Module (ISIM)	Other		0.00	0.00	72.23	132.37	161.51	174.57	175.27	165.24	145.21	115.55	76.39	27.68							1,246.02
05.09.06	ISIM Thermal Control System	Other				3.53	6.47	7.90	8.54	8.57	8.08	7.10	5.65	3.74	1.35							60.93
05.09.07	ISIM Structural System	Other				5.79	10.61	12.95	13.99	14.05	13.25	11.64	9.26	6.12	2.22							99.88
05.09.08	Lynx X-ray Microcalorimeter (LXM)	Instrument C				33.98	62.26	75.96	82.11	82.44	77.72	68.30	54.35	35.93	13.02							586.07
05.09.09	High Def'n X-ray Imager (HDXI)	Instrument D				15.46	28.34	34.58	37.37	37.52	35.37	31.09	24.74	16.35	5.93							266.75
05.09.10	XGS Grating Detector (XGD)	Instrument B				13.47	24.69	30.12	32.56	32.69	30.82	27.08	21.55	14.25	5.16							232.39
05.12	Lynx Telescope Calibration Facility	Other				3.05	5.98	6.81	7.36	7.39	6.97	6.13	4.87	3.22	1.17							52.55
06	Spacecraft Element	Spacecraft				65.15	119.38	145.65	157.43	158.07	149.02	130.96	104.21	68.89	24.97							1,123.73
07	Mission Operations	MO&DA																			120.05	
08	LV Services	Launch Services																			126.37	
		Ground Data System																			129.66	
09	Ground Systems	Dev				14.62	26.80	32.70	35.34	35.48	33.45	29.40	23.39	15.46	5.60							491.70
10	System Integration & Test	MSI&T				12.96	23.75	28.98	31.32	31.45	29.65	26.06	20.73	13.71	4.97							252.24
11	Public Outreach	Education/Outreach																				223.58
	Total Cost	Total Cost	53.48	52.97	67.76	55.10	131.93	304.54	588.10	680.91	735.97	738.97	696.66	730.38	446.54	244.51	127.16	130.46	133.85	137.33	140.90	6,601.75
	Pre-Phase A:		Total Phase E:																			669.70
			Total A-D:																			5,932.05
			Total Thru FY33:																			4,632.56
			Total A-E:																			6,601.75

Total Mission:
6,601.75

Real Year dollars, in millions



LYNX MISSION COST ESTIMATE (FY20 \$ M)

WBS	Lynx WBS Elements	RFI Elements	Phase A - D												Phase E and Total								
			Pre-Phase A			Phase A			Phase B			Phase C			Phase D			Phase E					
			FY22	FY23	FY24	FY25	FY26	FY27	FY28	FY29	FY30	FY31	FY32	FY33	FY34	FY35	FY36	FY37	FY38	FY39	FY40	FY41	FY42
			(10/21 - 10/24)	(10/24 - 10/26)	(10/26 - 4/28)	(4/28 - 7/35)	(7/35 - 11/36)	(11/36 - 11/41)															
01	Project Management	Other	2.40	5.60	5.23	9.34	11.11	11.70	11.44	10.51	9.00	6.97	4.49	1.59									89.38
02	Systems Engineering	Other	2.40	5.60	9.87	17.61	20.94	22.05	21.57	19.81	16.96	13.15	8.47	2.99									161.42
03	Safety & Mission Assurance	Other	1.20	2.80	3.31	5.92	7.03	7.41	7.24	6.65	5.70	4.42	2.84	1.00									55.52
04	Science & Technology	Science	50.60	48.80	62.80	98.61	12.16	14.45	15.22	14.88	13.67	11.70	9.07	5.84	2.06								246.73
05	X-ray Telescope (XRT)	Other	0.00	0.00	150.81	269.25	320.04	336.99	329.64	302.74	259.19	200.94	129.41	45.71									2,344.72
05.01	XRT Management	Other			1.21	2.15	2.56	2.69	2.63	2.42	2.07	1.61	1.03	0.37									18.74
05.02	XRT Systems Engineering	Other			2.27	4.06	4.82	5.08	4.96	4.56	3.90	3.03	1.95	0.69									35.32
05.03	XRT S&MA	Other			0.76	1.36	1.62	1.53	1.53	1.31	1.02	0.65	0.23										11.85
05.04	XRT Integration & Test	Other			2.30	4.11	4.89	5.15	5.03	4.62	3.96	3.07	1.98	0.70									35.81
05.05	XRT Calibration	Other			1.70	3.04	3.62	3.81	3.72	3.42	2.93	2.27	1.46	0.52									26.48
05.06	Lynx Mirror Assy. (LMA)	Instrument A			66.93	119.49	142.02	149.55	146.29	134.35	115.02	89.17	57.43	20.28									1,040.53
05.07	X-ray Grating Spectrometer (XGS) Grating Array (XGA)	Instrument B			4.04	7.22	8.58	9.03	8.83	8.11	6.95	5.38	3.47	1.22									62.83
05.08	Optical Bench Assy. (OBA)	Other			9.03	16.13	19.17	20.19	19.75	18.14	15.53	12.04	7.75	2.74									140.47
05.09	Integrated Science Instrument Module (ISIM)	Other			0.00	60.04	107.17	127.39	134.14	131.22	120.51	103.18	79.98	51.52	18.19								933.34
05.09.06	ISIM Thermal Control System	Other			2.94	5.24	6.23	6.56	6.42	5.89	5.05	3.91	2.52	0.89									45.65
05.09.07	ISIM Structural System	Other			4.81	8.59	10.21	10.75	10.52	9.66	8.27	6.41	4.13	1.46									74.81
05.09.08	Lynx X-ray Microcalorimeter (LXM)	Instrument C			28.24	50.41	59.92	63.09	61.72	56.68	48.53	37.62	24.23	8.56									439.00
05.09.09	High Def'n X-ray Imager (HDXI)	Instrument D			12.85	22.94	27.27	28.72	28.09	25.80	22.09	17.12	11.03	3.89									199.80
05.09.10	XGS Grating Detector (XGD)	Instrument B			11.20	19.99	23.76	25.02	24.47	22.48	19.24	14.92	9.61	3.39									174.08
05.12	Lynx Telescope Calibration Facility	Other			2.53	4.52	5.37	5.66	5.54	5.08	4.35	3.37	2.17	0.77									39.56
06	Spacecraft Element	Spacecraft			54.14	96.66	114.89	120.98	118.34	108.68	93.05	72.13	46.46	16.40									841.73
07	Mission Operations	MO&DA																					384.35
08	LV Services	Launch Services																					335.80
09	Ground Systems	Ground Data System																					188.95
10	System Integration & Test	MS&T																					167.45
11	Public Outreach	Education/Outreach																					22.75
	Total Cost		50.60	48.80	62.80	48.26	112.61	253.09	451.87	537.11	565.58	553.21	508.09	518.94	421.17	301.13	160.64	81.42	81.42	81.42	81.42	81.42	4,838.80
	Pre-Phase A:		162.20																				
	Total Thru FY33:																						3,548.76
	Total A-D:																						4,431.70
	Total Phase E:																						407.10
	Total Mission:																						4,838.80

FY20 Dollars, in millions

**C O S T
Q U E S T I O N 5**

For those partnering with foreign agencies, provide a second Mission Cost Funding Profile table and indicate the total mission costs clearly indicating the assumed NASA and contributed costs.

Primary reference: [Lynx Report](#), §8.5.4 (p. 256).

No foreign contributions were included in the *Lynx* cost estimate. However, the *Lynx* team welcomes international participation. Potential areas of contribution could include instruments, building on existing collaborations related to *Athena* and *XRISM*, as well as other previous X-ray missions. Other potential areas could involve a distinct contribution to the spacecraft and calibration support. Specific cost contributions will be sought out and defined more formally during pre-Phase A.