



International Space Station Lithium-Ion Battery Status

NASA Aerospace Battery Workshop

November 19, 2019

Penni J. Dalton, NASA Glenn Research Center

Ebony Bowens, The Boeing Company

Tim North, The Boeing Company

Sonia Balcer, Aerojet Rocketdyne



ISS Li-Ion Battery - Outline

- Configuration of Existing ISS Electric Power System
- ISS Upgrade to Li-Ion
- Launch History
- Battery Charge Control & On-Orbit Cycling Data
- Typical Capacity Test Battery
- Cell Life Test Data
- On-Orbit Operations
- Forward Work

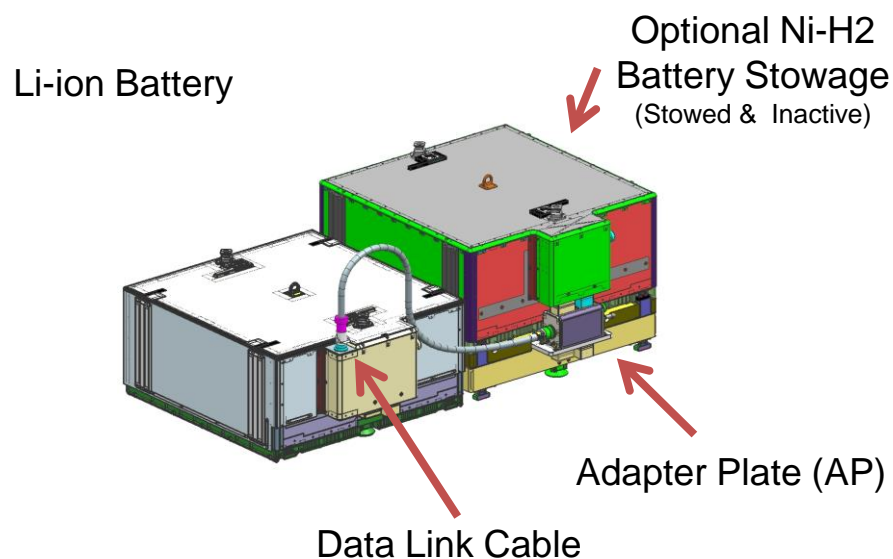



ISS Configuration - Battery Locations

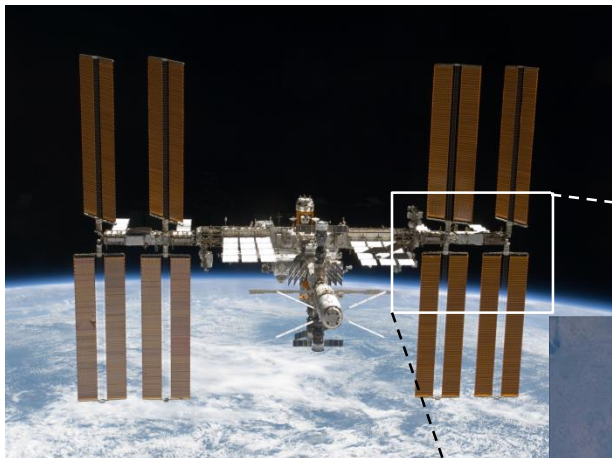

Batteries are located in the 4 Integrated Equipment Assemblies (IEAs)

2 Power Channels per IEA

8 Power Channels total

1 Li-Ion and 1 Adapter Plate replace 2 Ni-H₂

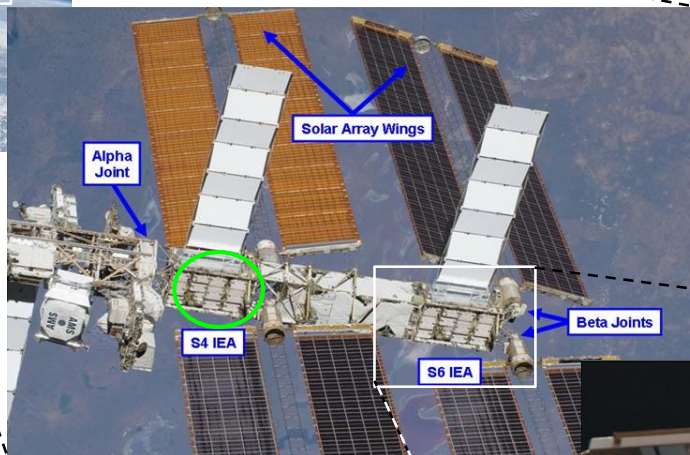

Initial Configuration:

- 6 Ni-H₂ ORUs per 8 channels – 48 total

Final Configuration:

- 3 Li-Ion ORUs per 8 channels – 24 total

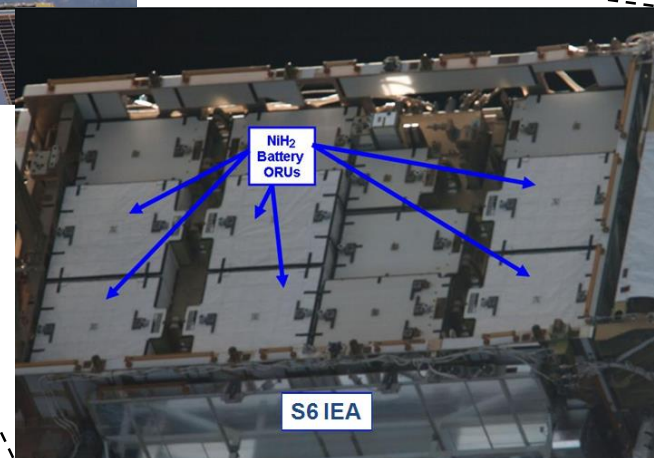



ISS Configuration - EPS Schematic

Electrical Power Channel – 1 of 8

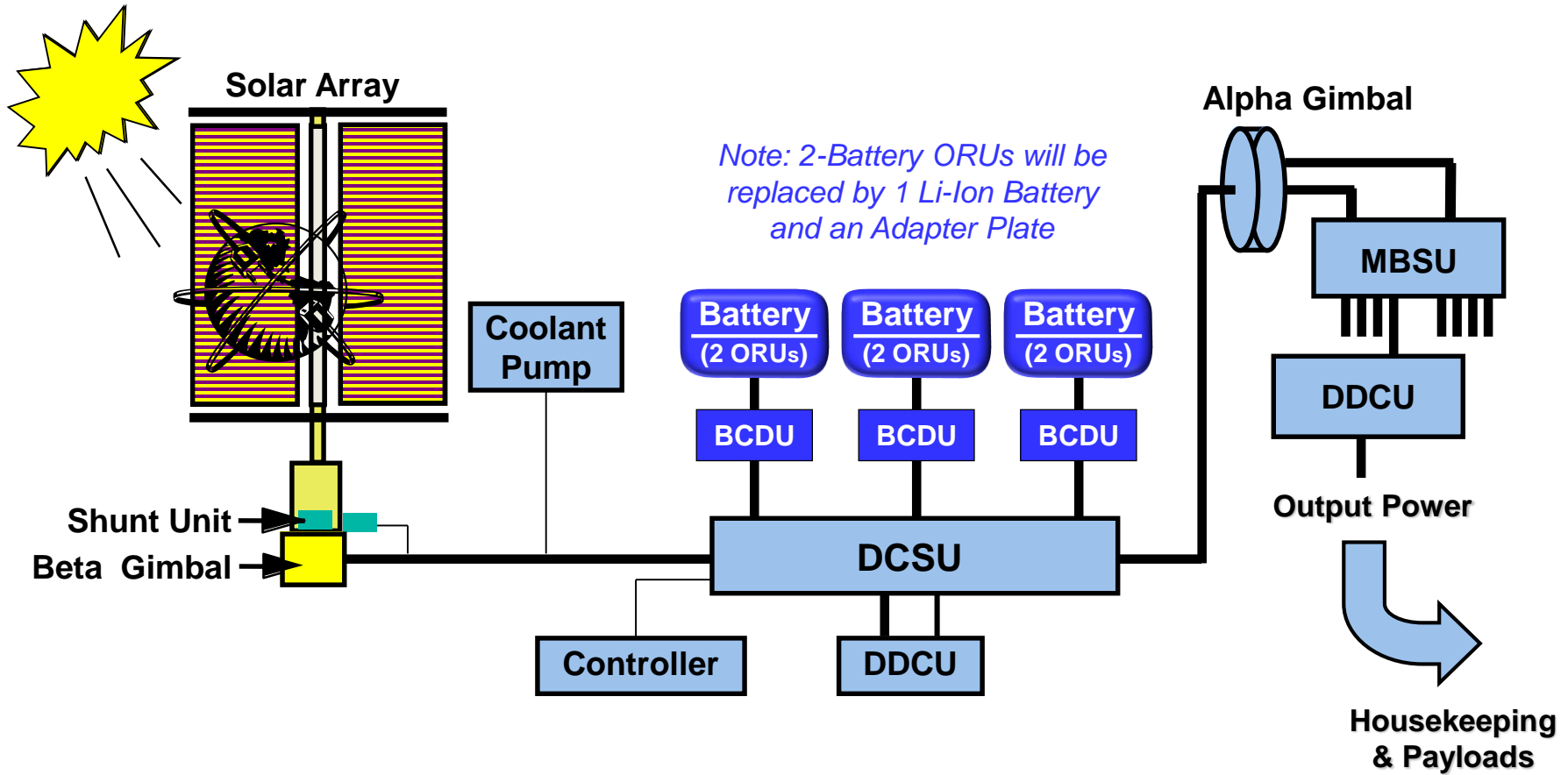

EPS:: Electric Power System
BCDU: Battery Charge / Discharge Unit
DCSU: DC Switching Unit
DDCU: DC-to-DC Converter Unit
MBSU: Main Bus Switching Units



ISS Upgrade to Li-Ion



Ni-H₂ (76 81 Ah cells in series)

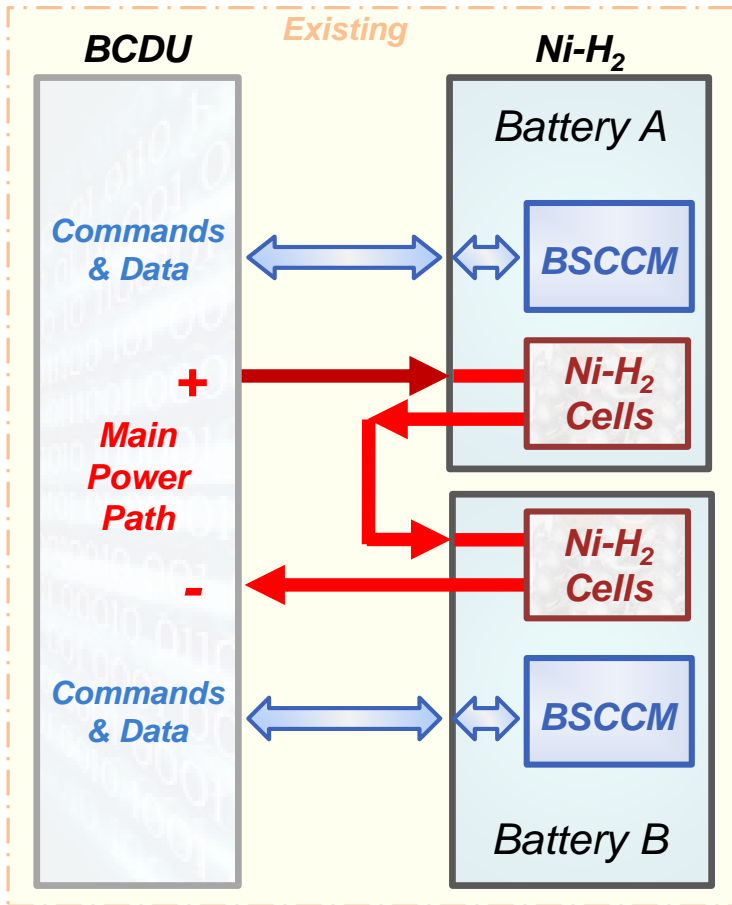

Li-Ion (30 134 Ah cells in series)

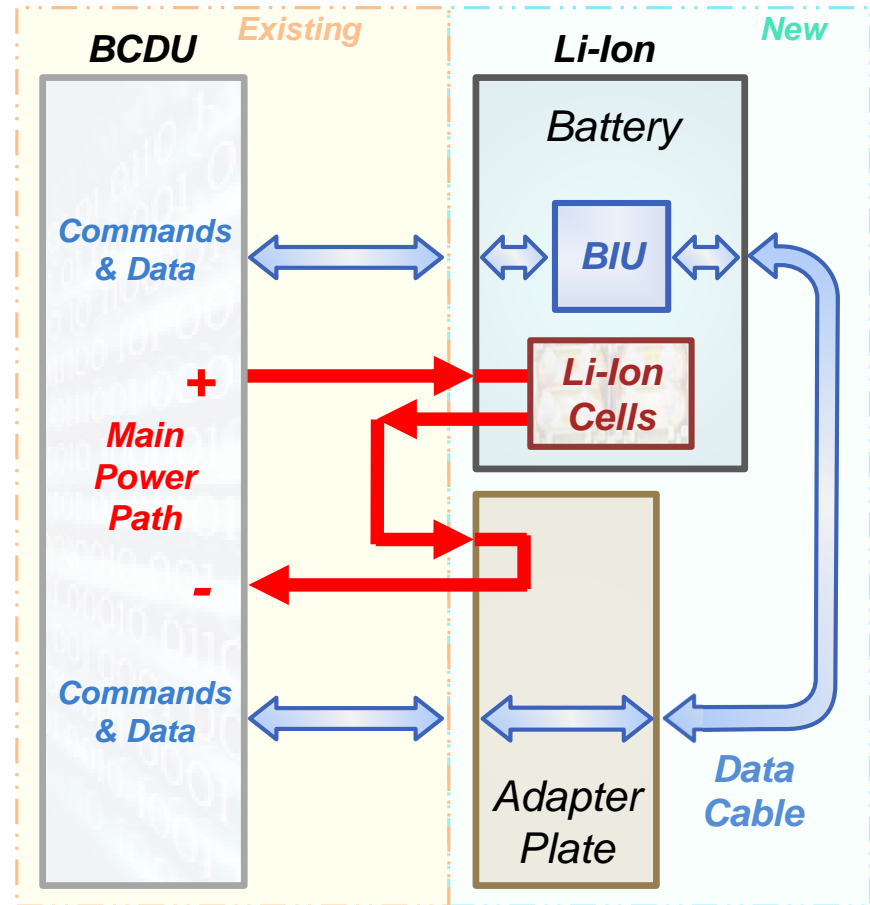

BCDU: Battery Charge / Discharge Unit
BIU: Battery Interface Unit
BSCCM: Battery Signal Conditioning and Control Module



ISS Li-Ion Orbital Replacement Units



Heater Mat
Heater Plate Assembly

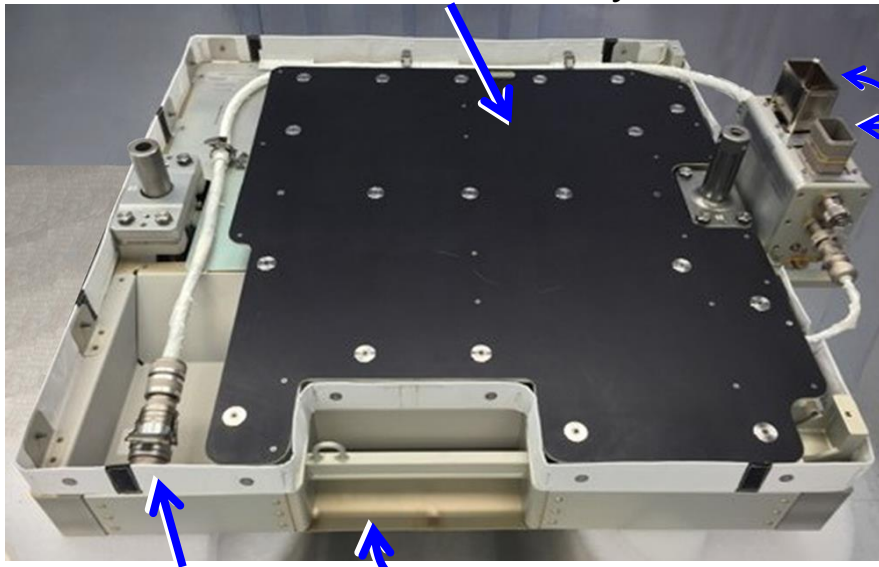

P4 Connector
(stowed for launch)

EVA
Hand Hold &
Tether

Dummy
Connectors

Adapter Plate ORU

Dimensions (LxWxH): ~ 41" x 36" x 15"
Spec Weight: 85 Lbs

J4
Connector

EVA
Tether

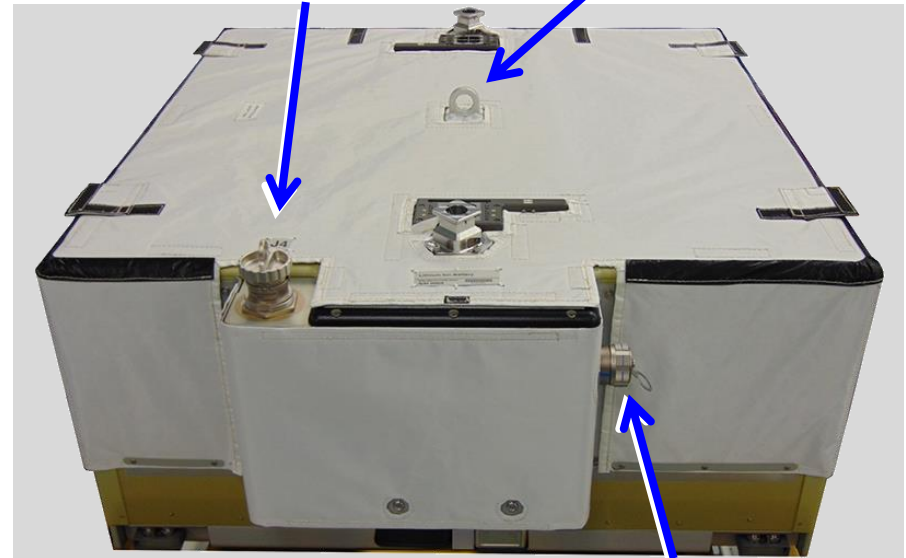

P1 & P2
Connectors

J3 Test
Connector

Li-ion Battery ORU

Dimensions (LxWxH): ~ 41" x 37" x 21"
Spec Weight: 435 Lbs



Launch History



- Launch on HTV6: December 9, 2016

- Installation and start-up on ISS:
 - S4 3A channel – Jan. 6, 2017
 - S4 1A channel, Jan. 13, 2017



- Launch on HTV7: September 22, 2018

BCDU failure blew the fuse in one of the new Li-Ion batteries

- One IEA Mixed Configuration operating with 2 Li-Ion and 1 pair of NiH2 ORUs since April 27, 2019
- Spare for 4A3 launching on SpX-19 (Dec. 2019)
- Installation and start-up on ISS:
 - P4 4A channel – March 22, 2019
 - P4 2A channel – March 29, 2019



- Launch on HTV8: September 24, 2019

- Installation and start-up on ISS:
 - P6 2B channel – Oct. 18, 2019
 - P6 4B channel – TBD





ISS Li-Ion Charge Control and Cycling

- Li-Ion charge current profile is based on cell voltages
- Cell bypass/balancing at EOCV every orbit
- EOCV ground command-able

Charge Current Profile		
	Highest of the Cell Terminal Voltages	Charge Current
Point 1	EOCV + 19mV	55
Point 2	EOCV + 19mV	49
Point 3	EOCV + 18mV	44
Point 4	EOCV + 17mV	39
Point 5	EOCV + 16mV	36
Point 6	EOCV + 15mV	33
Point 7	EOCV + 14mV	30
Point 8	EOCV + 13mV	26
Point 9	EOCV + 12mV	22
Point 10	EOCV + 11mV	19
Point 11	EOCV + 10mV	16
Point 12	EOCV + 9mV	13
Point 13	EOCV + 8mV	10
Point 14	EOCV + 7mV	7
Point 15	EOCV + 6mV	4
Point 16	not applicable	1

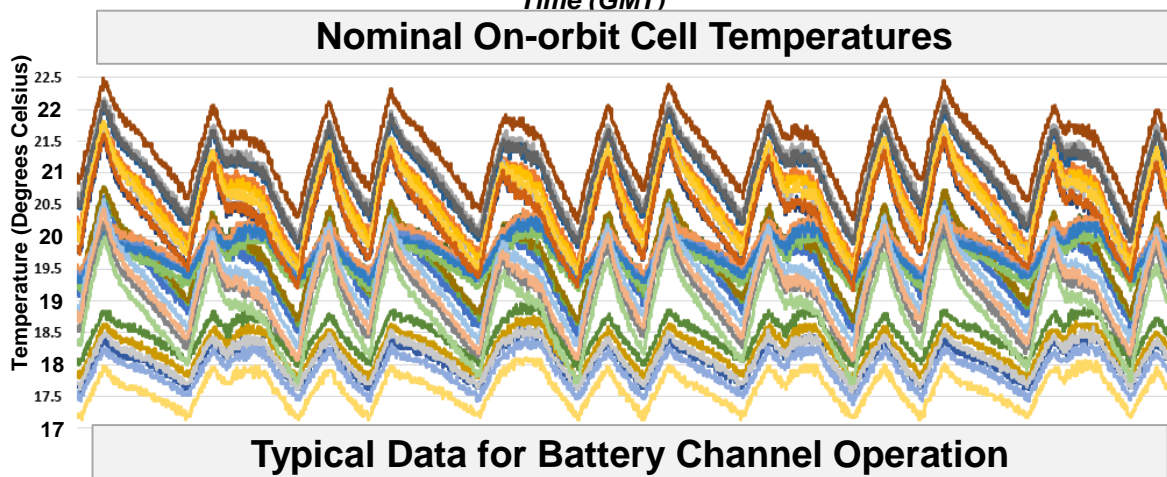
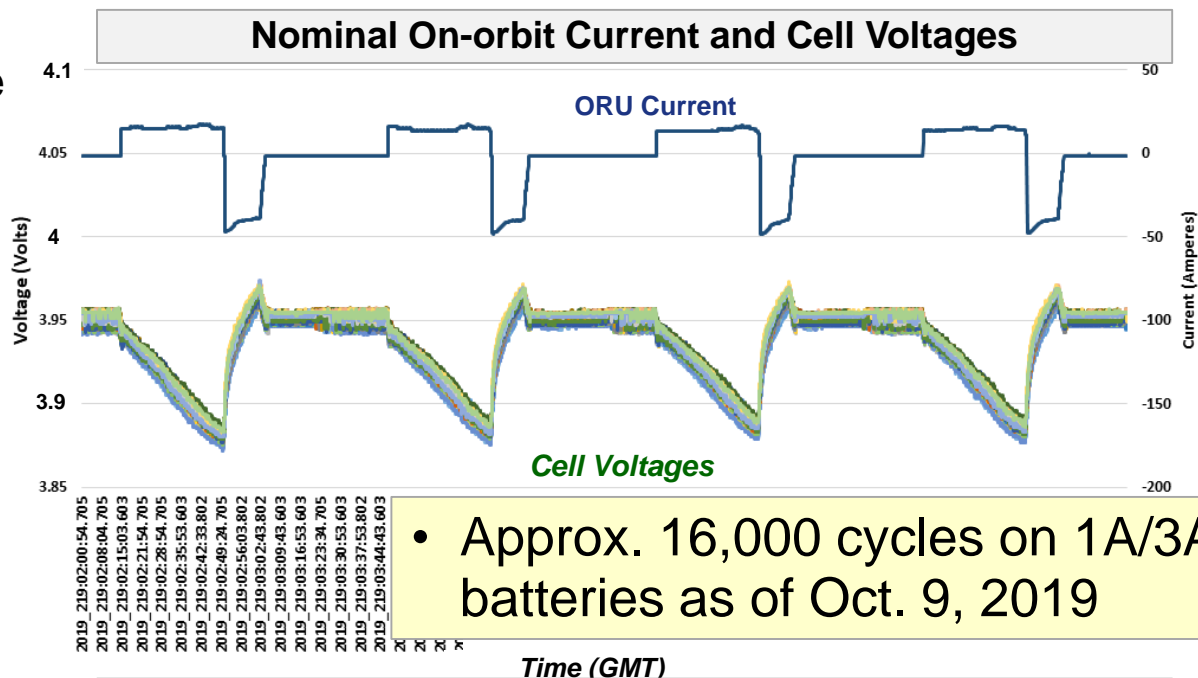



ISS Li-Ion Start-up Capacity Test



Typical Li-Ion Battery Capacity Test

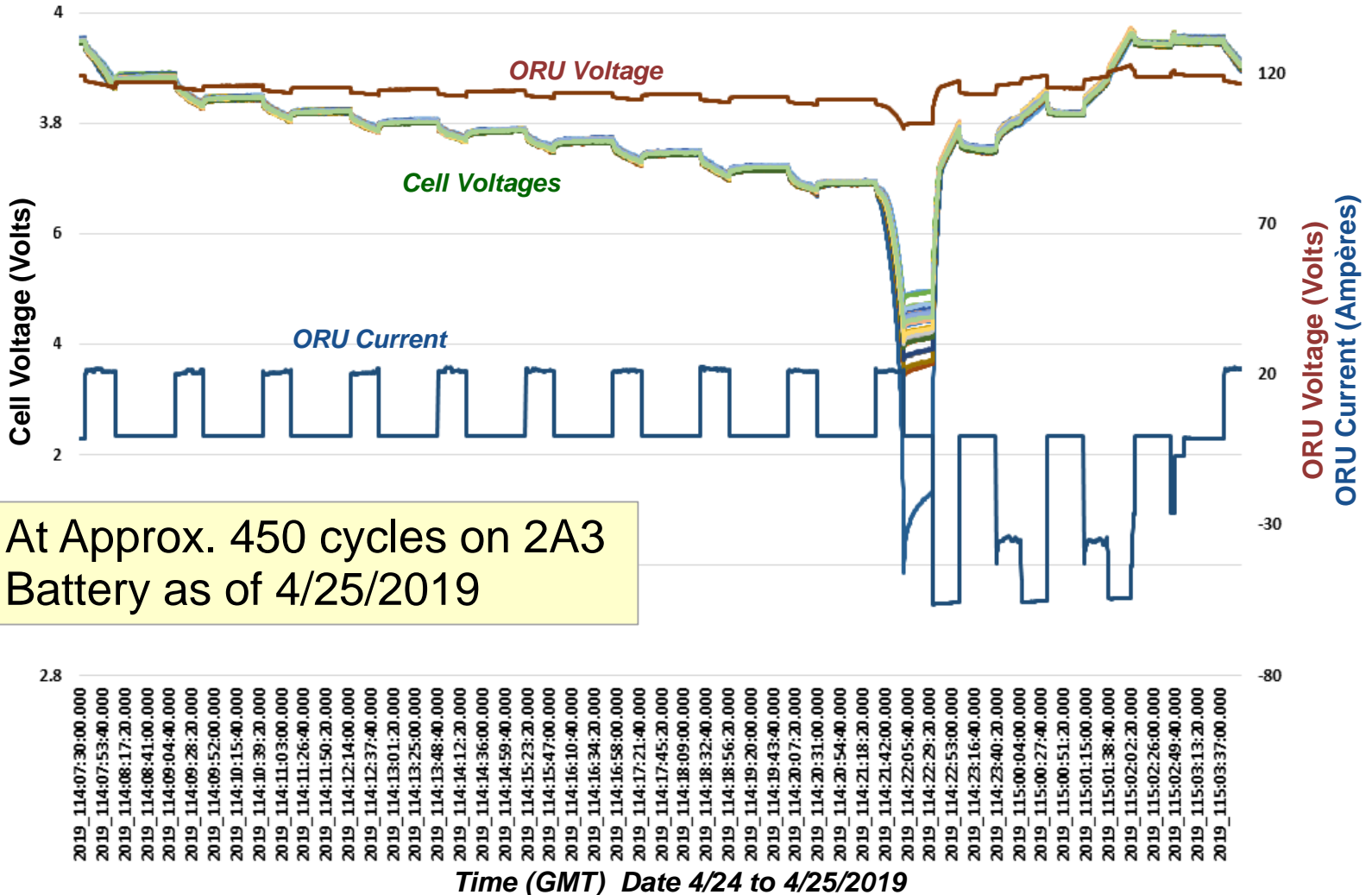

- At Approx. 450 cycles on 2A3 Battery as of 4/25/2019



Life Test Program

- Cell Life Testing performed at Crane Lab and NASA-GRC

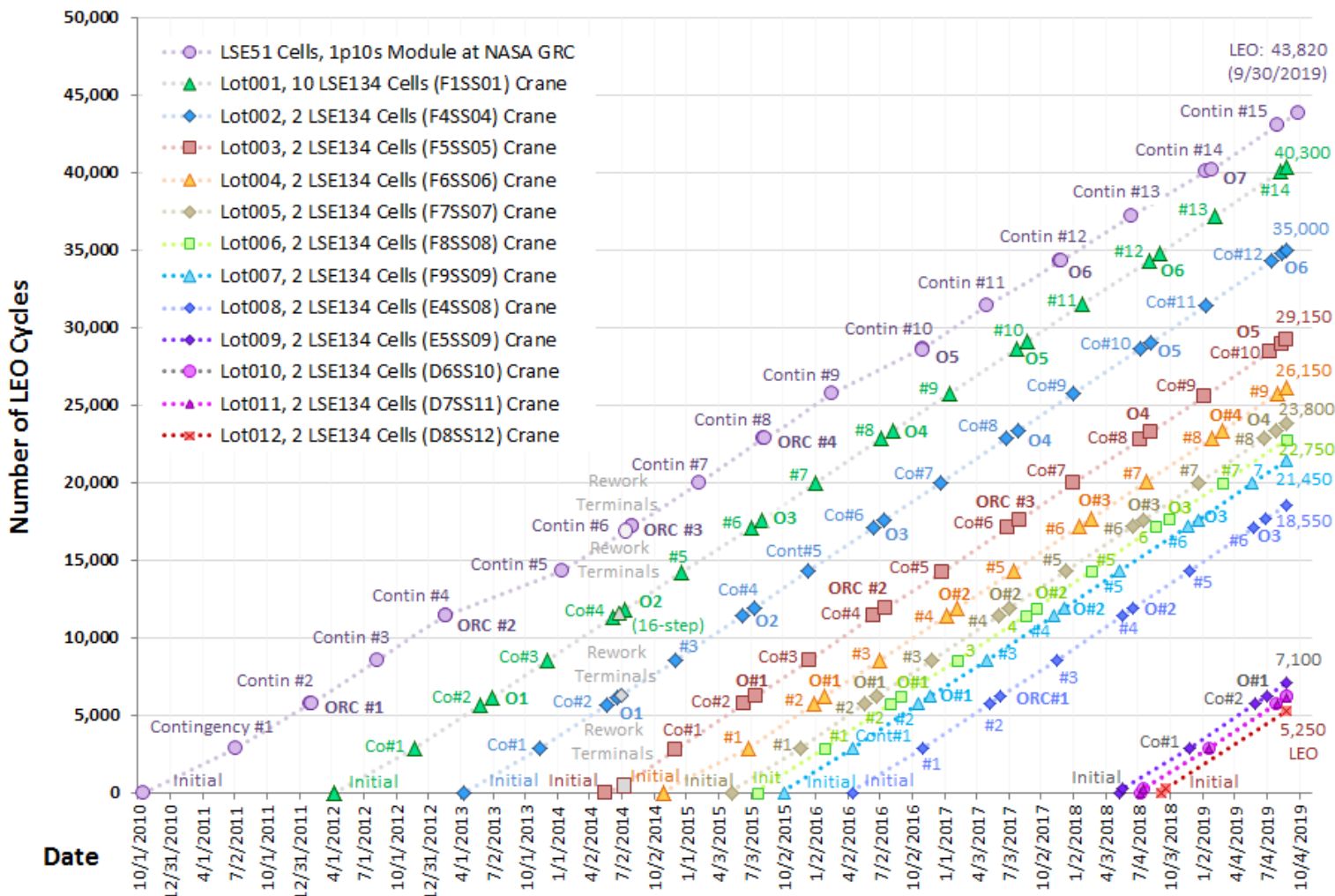



Life Test Program

ORC Capacity Data for Life Test of LSE134 Cells at Crane

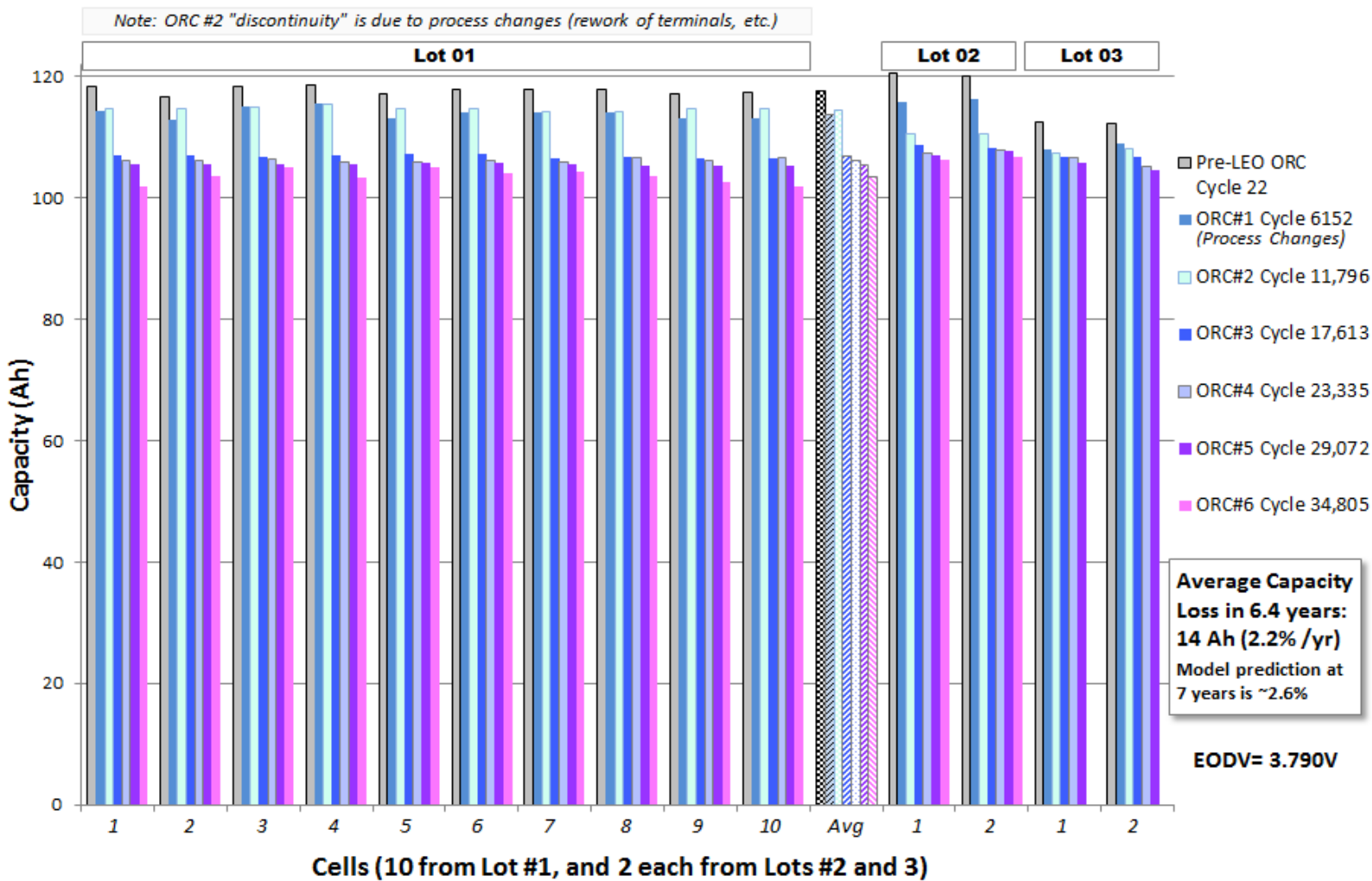



S4 Li-Ion Battery Orbit Operations



- Starting January 13, 2017, S4 Channels 3A and 1A are being operated using only Li-Ion Batteries
 - Batteries are performing well after ~16,000 LEO cycles
 - Batteries being operated at EOCV of 3.95V
 - Cell EODVs within ~10 mV
 - Cell temperatures within 5 degrees C
 - Initial and Annual On-Orbit Capacity tests performed
 - Results in line with GS Yuasa model



Battery Location	Start Up Capacity (Ahr), Jan. 2017	Annual Capacity (Ahr), Feb. 2018	Annual Capacity (Ahr), Feb. 2019
1A1	113.1	111.0	109.9
1A2	109.7	107.5	107.1
1A3	111.6	109.8	108.7
3A1	108.7	107.4	106.4
3A2	110.0	108.2	107.1
3A3	110.4	109.1	107.5



S4 Performance

S4 Capacity Data has been trending well within the expected range of capacity loss based on battery life performance test data and model predictions.

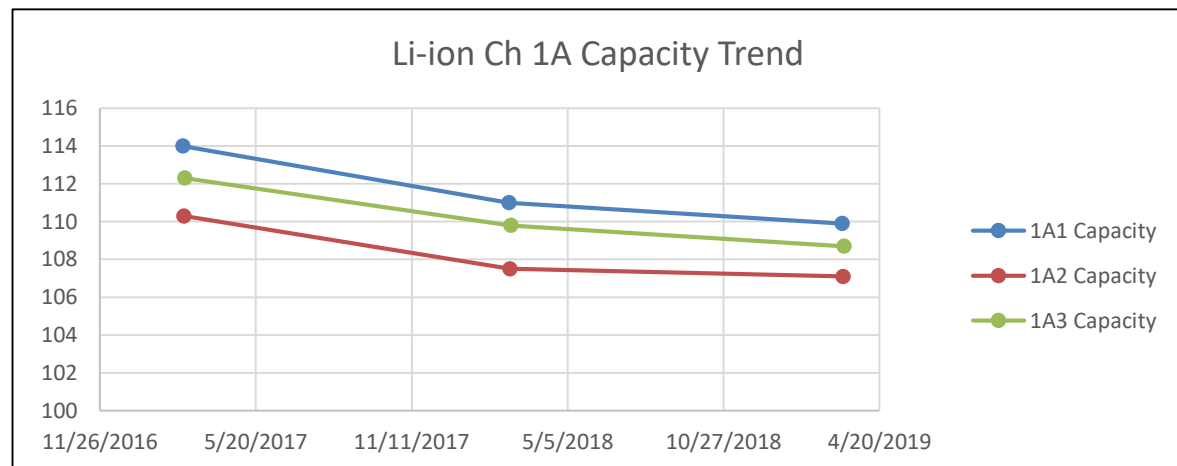
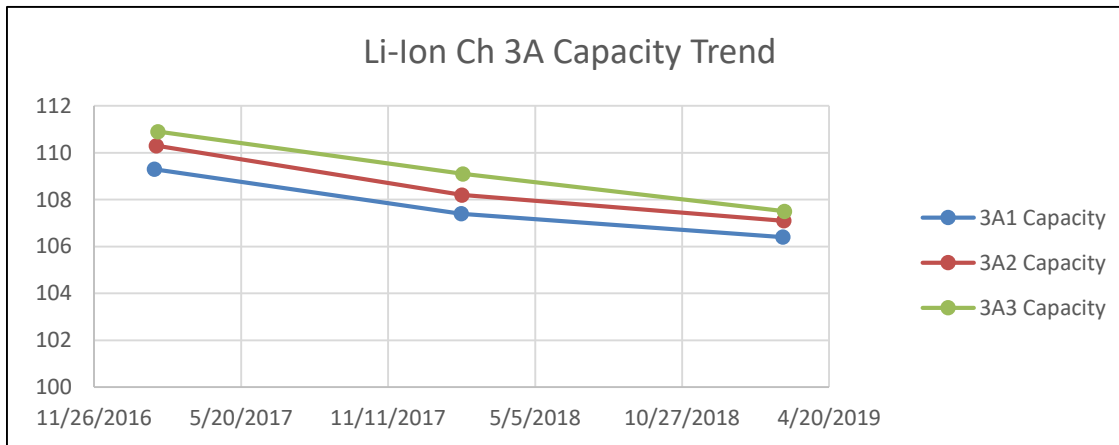



P4 Li-Ion Battery Operations

- Starting March 22, 2019, P4 Channels 4A operating in Mixed Configuration and Channel 2A operating with only Li-Ion Batteries
 - These Batteries have been performing after ~3,400 LEO cycles
 - Li-Ion Batteries being operated at EOCV of 3.95V
 - Cell EODVs within ~10 mV
 - Cell temperatures within 5 degrees C
 - NiH₂ Battery being operated nominally
 - Cell temperatures within 0 to 20 degrees C



Battery Location	Start Up Capacity (Ahr), April 2019
2A1	109.6
2A2	110.5
2A3	105.4
4A1	N/A
4A2	N/A
4A3*	56.8



*4A3 is NiH₂ Battery Pair

Performing quarterly capacity test to closely monitor the performance



P6 Install in Work

- Starting October 18, 2019, P6 Channels 2B began operating with only Li-Ion Batteries
- P6 Channel 4B battery upgrades are TBD.





In Closing

- The first set of six ISS Li-ion Batteries continues to operate, meeting or exceeding expectations
- 5 out of 8 channels have been upgraded and are operating with Li-Ion
- The final set of six ISS Li-Ion Batteries is planned to launch on HTV-9 May 2020
- Questions?