

NASA/TP-2019-220432

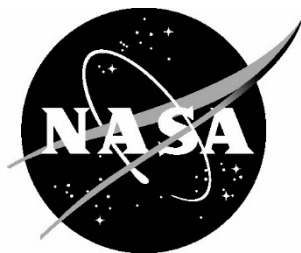

The TASAR Project: Launching Aviation on an Optimized Route Toward Aircraft Autonomy

*David J. Wing
Langley Research Center, Hampton, Virginia*

December 2019

NASA STI Program . . . in Profile

Since its founding, NASA has been dedicated to the advancement of aeronautics and space science. The NASA scientific and technical information (STI) program plays a key part in helping NASA maintain this important role.

The NASA STI program operates under the auspices of the Agency Chief Information Officer. It collects, organizes, provides for archiving, and disseminates NASA's STI. The NASA STI program provides access to the NTRS Registered and its public interface, the NASA Technical Reports Server, thus providing one of the largest collections of aeronautical and space science STI in the world. Results are published in both non-NASA channels and by NASA in the NASA STI Report Series, which includes the following report types:

- **TECHNICAL PUBLICATION.** Reports of completed research or a major significant phase of research that present the results of NASA Programs and include extensive data or theoretical analysis. Includes compilations of significant scientific and technical data and information deemed to be of continuing reference value. NASA counter-part of peer-reviewed formal professional papers but has less stringent limitations on manuscript length and extent of graphic presentations.
- **TECHNICAL MEMORANDUM.** Scientific and technical findings that are preliminary or of specialized interest, e.g., quick release reports, working papers, and bibliographies that contain minimal annotation. Does not contain extensive analysis.
- **CONTRACTOR REPORT.** Scientific and technical findings by NASA-sponsored contractors and grantees.

- **CONFERENCE PUBLICATION.** Collected papers from scientific and technical conferences, symposia, seminars, or other meetings sponsored or co-sponsored by NASA.
- **SPECIAL PUBLICATION.** Scientific, technical, or historical information from NASA programs, projects, and missions, often concerned with subjects having substantial public interest.
- **TECHNICAL TRANSLATION.** English-language translations of foreign scientific and technical material pertinent to NASA's mission.

Specialized services also include organizing and publishing research results, distributing specialized research announcements and feeds, providing information desk and personal search support, and enabling data exchange services.

For more information about the NASA STI program, see the following:

- Access the NASA STI program home page at <http://www.sti.nasa.gov>
- E-mail your question to help@sti.nasa.gov
- Phone the NASA STI Information Desk at 757-864-9658
- Write to:
NASA STI Information Desk
Mail Stop 148
NASA Langley Research Center
Hampton, VA 23681-2199

NASA/TP-2019-220432

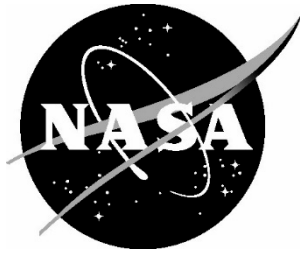

The TASAR Project: Launching Aviation on an Optimized Route Toward Aircraft Autonomy

*David J. Wing
Langley Research Center, Hampton, Virginia*

National Aeronautics and
Space Administration

Langley Research Center
Hampton, Virginia 23681-2199

December 2019

The use of trademarks or names of manufacturers in this report is for accurate reporting and does not constitute an official endorsement, either expressed or implied, of such products or manufacturers by the National Aeronautics and Space Administration.

Available from:

NASA STI Program / Mail Stop 148
NASA Langley Research Center
Hampton, VA 23681-2199
Fax: 757-864-6500

Abstract

The Traffic Aware Strategic Aircrew Request (TASAR) concept applies onboard automation for the purpose of advising the pilot of route modifications that would be beneficial to the flight. Leveraging onboard computing platforms with connectivity to avionics and diverse data sources on and off the aircraft, TASAR introduces a new, powerful capability for in-flight trajectory management to the cockpit and its flight crew that is anticipated to induce a significant culture change in airspace operations. Flight crews empowered by TASAR and its derivative technologies could transform from today's flight plan followers to proactive trajectory managers, taking an initial critical step towards increasing autonomy in the airspace system. TASAR was developed as a catalyst for operational autonomy, a future vision where the responsibilities and authorities of trajectory management reside with the aircraft operator and are distributed among participating aircraft, thus fulfilling a vision dating back decades and enabling a fully scalable airspace system. This NASA Technical Paper maps TASAR to its foundational vision and traces its research and development from initial concept generation to an operational evaluation by a U.S. airline in revenue service, the final stage before technology transfer and commercialization.

Acknowledgements

The TASAR project was an extensive, multi-disciplinary, multi-organizational activity and achievement that required a substantial team effort to be successful. The author expresses deepest thanks to all who were involved at various points along the project timeline, including the following individuals, contracts, and external organizations:

NASA TASAR Team: Nash'at Ahmad, Kate Ballard, Terique Barney, Bill Buck, Kelly Burke, Andy Carnell, Stephanie Harrison, Tim Lewis, Anna Noe, Matt Underwood, Sara Wilson

NASA TASAR Support: Keith Arthur, Mark Ballin, Brian Baxley, Elaine Blount, Sheri Brown, Tony Busquets, Bill Cann, Jordan Davis, Robin Edwards, Jim Fay, George Finelli, Dana Gould, Trevor Grondin, Stella Harrison, Jennifer Kibler, Bonnie Lumanog, Jesse Midgett, Mike Palmer, Jason Pullias, Carrie Rhoades, Jennifer Riley, Lisa Rippy, Ed Scarce, Steve Velotas

NASA Research Announcement Contracts:

Engility Corporation / Advanced Aerospace Solutions: Eric Cardon, Steve DePascale, Gabriele Enea, Mark Haynes, Jeff Henderson, Husni Idris, Ludovic Laberge, Marie-Hélène Larose, Brendan Lefebvre, John Maris, Dave Roscoe, Puthy Soupín, Tommy Thurber, Bob Vivona, Sharon Woods

Rockwell Collins / University of Iowa: Michael Choi, Matt Cover, Joe Engler, Greg Fletcher, Adam Gary, Charles Goddard, Steve Koczo, Richard Miller, Chris Reuter, Tom Schnell, Michael Yocius

NASA In-House Contracts:

LAMPS: Nita Bond, Angela Bruce, Keshia Newsome, Whitney Rush, Pat Watson-Cumberbatch

LITES: Brenda Andrews, Beau Branch, Bill Coppedge, Andres Danziger, Jim Davis, Mike Day, Steve DePascale, Randy Dye, Chris Fieldman, Jeffrey Henderson, Richard Jessop, David Karr, Joe King, Brendan Lefebvre, Michael Lewis, Ron Maddox, Richard Maine, Joe Mason, Doug Mielke, Brendan Moeller, Bill O'Neil, Joey Ponthieux, Dave Roscoe, Jonathan Starr, Jim Sturdy, Jerry Thomas, Bob Vivona, Chris Ware, Sharon Woods, Chris Wyatt

NIA: Bill Cotton, Sam Grainger, Mark Haynes, Clay Hubbs, John Maris

TEAMS: Tom Britton, Mike Harper, Carolyn McGee

External Organizations:

Air Line Pilots Association, Alaska Airlines, Aviation Communication & Surveillance Systems, Collins Aerospace, Eurocontrol, Gogo Commercial Aviation, Federal Aviation Administration, GE Aviation, National Air Traffic Controllers Association, National Oceanic and Atmospheric Administration, The Boeing Company, Virgin America

Table of Contents

Abstract	i
Acknowledgements	ii
Table of Contents	iii
List of Figures	iv
List of Tables	v
1. Introduction	1
2. Motivation	3
3. Concept Description	8
4. Project Approach	11
5. Benefits Assessment	16
6. Safety Assessment	25
7. Authorization Assessment	30
8. Market Assessment	35
9. Technology Prototype	44
10. Human Factors Assessment	57
11. Flight Trials	70
12. Operational Evaluation	106
13. Technology Transfer and Beyond	134
14. Conclusion	144
15. Abbreviations	146
16. References	150

List of Figures

Figure 1. The TASAR concept.	8
Figure 2. Approximate calendar-year timeline of the TASAR project.....	14
Figure 3. TASAR benefit mechanisms. From ref. [17].	18
Figure 4. Models in TASAR simulation platform. From ref. [17].	18
Figure 5. Average TASAR time savings by stage length and airport size. From ref. [17].....	20
Figure 6. TASAR time savings for aircraft traveling between DFW and LGA. From ref. [17]. .	20
Figure 7. Variety of inputs and algorithms used by TAP for conflict-free route optimization. ...	47
Figure 8. TAP v15-4 user interface shown in Auto Mode.....	49
Figure 9. TAP v15-4 user interface shown in Manual Mode depicting a traffic conflict.....	49
Figure 10. TAP's distributed system architecture. <i>Credit M. Underwood.</i>	50
Figure 11. Beneficial non-direct route modification identified by TAP's genetic algorithm.....	55
Figure 12. Flight simulator with TAP v2 on the Captain's EFB. <i>Photo by M. Cover.</i>	58
Figure 13. Simulated TASAR flight for HITL simulation experiments.....	59
Figure 14. TAP v2 user interface tested in HITL-1.	60
Figure 15. TAP v14-1 user interface tested in HITL-2. TAP v15-2 used a similar design.	63
Figure 16. TAP Computer-Based Trainer.....	64
Figure 17. Piaggio Avanti flight-test aircraft used in FT-1 and FT-2. <i>Photo by author.</i>	72
Figure 18. EFB installation in the Avanti Cockpit. <i>Photo by Advanced Aerospace Solutions.</i>	73
Figure 19. TAP v3 user interface tested in FT-1.	74
Figure 20. FT-1 round robin routes from KPHF. From ref. [51].....	75
Figure 21. FT-1 SUA avoidance example. <i>Base image from Google Earth™</i>	78
Figure 22. FT-2 representative routes. <i>Base image from Google Earth™</i>	81
Figure 23. Architecture comparison of Alaska Airlines and FT-2 test configurations.....	82
Figure 24. Geometry characteristics of TAP solutions.	95
Figure 25. TAP v15-2 user interface tested in FT-2, shown in portrait mode.....	96
Figure 26. FT-2 pilot subjective ratings of using TAP. From ref. [54].	97
Figure 27. FT-2 ratings of the three primary TAP Display screens. From ref. [54].....	98
Figure 28. NASA HU-25A Guardian flight test aircraft used in FT-3. From ref. [56].	101
Figure 29. GDS convective weather polygons. <i>Base image from Google Earth™</i>	102
Figure 30. Airborne weather radar data and polygons generated by AWRP. From ref. [45].....	103
Figure 31. TAP v15-2 map display with time slider. From ref. [45].....	104
Figure 32. Multi-organizational team for the TASAR operational evaluation. From ref. [60]. .	109
Figure 33. System architecture for the Alaska Airlines operational evaluation. From ref. [60].	110
Figure 34. First of three Alaska Airlines aircraft to be equipped for TASAR. <i>Photo by author.</i>	113
Figure 35. NASA researcher operating TAP from the jump seat. <i>Photo by K. Burke.</i>	116
Figure 36. TAP Operator training in the Alaska Airlines flight simulator. <i>Photo by author.</i>	118
Figure 37. TAP flights used in the benefits analysis. From ref. [61].....	118
Figure 38. Calculating cost savings on TAP flights and baseline flights. From ref. [62].....	121
Figure 39. Distribution of estimated cost savings for the 90 valid flights. From ref. [62].	125
Figure 40. "Home Run" TASAR benefit case. From ref. [61]. <i>Photo by author.</i>	129
Figure 41. "Cumulative Small Gains" TASAR benefit case. From ref. [61]. <i>Photo by author.</i> ..	129
Figure 42. "Plan Validation" TASAR benefit case. From ref. [61].....	130
Figure 43. Roadmap from TASAR to full airborne trajectory management. From ref. [7].	142

List of Tables

Table 1. NASA Technology Readiness Level scale.	12
Table 2. Model-based estimate of TASAR savings per operation. From ref. [17].	21
Table 3. Virgin America estimated annual TASAR benefits by aircraft type. From ref. [18].	22
Table 4. Alaska Airlines estimated annual TASAR benefits by aircraft type. From ref. [19].	22
Table 5. Virgin America estimated annual cost savings from TASAR. From ref. [18].	23
Table 6. Alaska Airlines estimated annual cost savings from TASAR. From ref. [19].	23
Table 7. Diverse industries with diverse motivations for TASAR commercialization.	39
Table 8. TAP software version history.	44
Table 9. TASAR use cases exercised in HITL-1.	59
Table 10. TASAR use cases used in the second flight in HITL-2.	67
Table 11. FT-1 test matrix. From ref. [51].	75
Table 12. Controlled ATC acceptability factors evaluated in FT-2. From ref. [53].	89
Table 13. Complexity characteristics of TAP route modification advisories.	94
Table 14. TAP CRM configurations evaluated in FT-2.	99
Table 15. Operational evaluation limitations and effects on achieved benefits. From ref. [62].	122
Table 16. Aggregate TASAR benefit results corresponding to 90 valid flights. From ref. [62].	124
Table 17. Aggregate TASAR benefit results by flight length. From ref. [62].	126
Table 18. Aggregate TASAR benefit results by TAP Operator. From ref. [62].	126
Table 19. Estimated annual TASAR cost savings for the top 10 U.S. airlines. From [62].	135

1. Introduction

On July 24, 2018, Alaska Airlines conducted the first commercial-airline revenue flight with NASA's Traffic Aware Planner (TAP) prototype software installed onboard. Alaska Airlines pilots used TAP to optimize the flight path, saving substantial fuel and flight time, thereby saving operating cost and carbon emissions. This first flight and the dozens of evaluation flights that followed prepared Alaska Airlines to potentially lead the world in implementing “Traffic Aware Strategic Aircrew Requests” (TASAR), a novel and patented NASA concept for en route flight-path optimization and a transformational advancement toward future operational autonomy in the national airspace. It is a rare achievement to transition NASA research software from the laboratory to a commercial airline operational environment, and the achievement is a testament to the diverse, multi-organizational team that collaborated over a seven-year period to execute an aggressive strategy of research, development, testing, deployment, and operational evaluation. Augmenting the non-reimbursable partnership between NASA Langley Research Center and Alaska Airlines were self-funded industry leaders Collins Aerospace, Gogo Commercial Aviation, and Aviation Communications & Surveillance Systems, each making valuable contributions critical to the success of the operational evaluation and therefore to the future potential of the technology in airspace operations. The fact that these companies would invest their own funds over multiple years in the TASAR evaluation illuminates the degree of interest and traction this new technology has quickly achieved in the commercial sector and previews the potential long-term success of the technology and its strategic goals.

The Alaska Airlines operational evaluation of TASAR was the culminating activity of a research and development strategy that attempted to motivate the first stages of a new transformation to a long-held vision of aircraft operational autonomy in the airspace system [1]–[5]. This vision holds that aircraft operators, when supported by advanced cockpit-based trajectory-management automation infused with real-time information about the dynamically evolving airspace environment, are able to independently oversee and safely manage the aircraft’s route throughout the majority of their flight even in Instrument Meteorological Conditions (IMC), as many aircraft do today in Visual Meteorological Conditions (VMC) operating under Visual Flight Rules (VFR). An expansion of the vision also holds that such “autonomous operations” can safely and equitably share the airspace on a non-interfering basis with aircraft operating under Instrument Flight Rules (IFR) within the dominion and active oversight of Air Traffic Control (ATC) [6]. Introducing aircraft operational autonomy in this manner, through a concept of “Autonomous Flight Rules” (AFR), offers tremendous potential for airspace capacity to grow substantially to meet future demand while posing no threat to the complex IFR and ATC system of today and the aircraft operators choosing to continue operating under IFR.

Achieving this vision of aircraft operational autonomy in IMC will require infusion of new cockpit technology and a culture shift in the role of the pilot. The technology will perform the functions needed to maintain a safe and efficient plan for the aircraft as it proceeds through the challenges of the airspace ahead (e.g., dense traffic, wind changes, dynamic weather). The culture shift may be more difficult to achieve than the technology in that it requires pilots to be active trajectory managers throughout the flight. Pilots operating under IFR today perform this role at times but typically only for limited periods when maneuvering tactically around weather. The culture in IFR otherwise dictates that pilots will generally follow the plan devised for their flight

Introduction

and filed with ATC before departure, and they will follow instructions from ATC while en route for purposes of traffic separation and flow management. Aircraft operational autonomy will need an evolved pilot culture that is more “proactive trajectory manager” than “reactive plan follower” (similar to IFR flight near weather, and VFR flight nearly always) where pilots are less constrained by an initial plan and are both empowered and encouraged to make changes as desired throughout the flight.

TASAR was developed as an innovative strategy to promote both of these elements essential to achieving future operational autonomy: new cockpit technology enabling *airborne trajectory management* and a culture shift for pilots toward being proactive airborne trajectory managers. The innovation of TASAR is to introduce the technology of future operational autonomy into current day operations, inducing a gradual shift in technology and culture towards airborne trajectory management and generating initial momentum in the airspace community toward future operational autonomy [7]. By focusing on the non-safety-critical aspect of airborne trajectory management, i.e., flight efficiency optimization, TASAR will enable the technology to safely mature at a measured pace through actual operational use and refinement toward its eventual future safety-critical function, while generating benefits for its operators through improvements in flight efficiency. At the same time, TASAR will begin to encourage that culture shift by acclimating pilots (and eventually all flight operations stakeholders) to the use of advanced cockpit-based trajectory management tools in their normal piloting routine.

NASA’s TASAR project was instituted in order to build a prototype of the cockpit technology and prepare it for technology transfer to the commercial aviation industry. The intent was for the technology to be commercialized and adopted by the airline community and eventually other aircraft operator communities. A series of activities were defined to facilitate successful and rapid technology transfer and to minimize risks of adoption by airlines. Such activities included preliminary assessments of expected benefits, safety, and approval requirements; development of airline pilot training materials; simulation evaluations of human factors; NASA flight trials using flight-test aircraft; and finally an operational evaluation by a partner airline in commercial revenue service.

This report summarizes the TASAR project from conception to its current state of completion: the Alaska Airlines operational evaluation and initial commercialization. Although many publications document the individual TASAR activities in greater detail, this report presents the full arc of the project. The project is somewhat unique given the span of technology readiness levels (TRL) achieved within a relatively short period for a NASA cockpit technology. This report is intended to aid and inspire future projects with similar goals, enhancing NASA’s ability to make further significant contributions to its Aeronautics mission and the airspace operations community. It also informs that community on the motivation and pedigree of TASAR.

The report is organized as follows. Chapter 2 further explores the motivation for TASAR. Chapter 3 summarizes the TASAR concept. Chapter 4 describes the objectives and approach for the project. Chapters 5, 6, and 7 review the various analytical assessments (benefits, safety, and approval) performed early in the project. Chapter 8 describes market research and community engagement in TASAR. Chapter 9 describes TAP, NASA’s prototype automation technology for TASAR. Chapters 10 and 11 review the human factors simulations and NASA flight trials. Chapter 12 summarizes the airline operational evaluation. Chapter 13 looks beyond the TASAR project to commercialization and potential derivative technologies on the roadmap to operational autonomy. Chapter 14 presents conclusions.

2. Motivation

The motivation for the TASAR project is rooted in an area of preceding NASA research: operational autonomy for airspace users. TASAR was conceived as a catalyst for achieving this future vision, wherein airspace users have the option to self-manage their aircraft trajectories while assuming the full responsibilities of safety. To provide the proper context, this report first reviews the motivation for operational autonomy. Discussion of the motivation for TASAR then follows in two parts: enabling this future vision of operational autonomy, and in the process, enhancing current-day flight efficiency.

2.1. Motivation for Future Operational Autonomy

At the highest level, all research in the NASA Aeronautics Research Mission Directorate is motivated by the vision set forth in the Strategic Implementation Plan (SIP) [8]. As the SIP states, the vision “encompasses a broad range of technologies to meet future needs of the aviation community, the nation, and the world for safe, efficient, flexible, and environmentally sustainable air transportation.” Among the six Strategic Thrusts listed in the SIP, three support the need for research into operational autonomy in aviation operations: Safe, Efficient Growth in Global Operations; Real-Time System-Wide Safety Assurance; and Assured Autonomy for Aviation Transformation. Even though these Strategic Thrusts were formulated long after NASA’s operational autonomy research began in the late 1990s, they underscore the continuing relevance of the research today. The key strategic goal for NASA Aeronautics in the 1990s and early 2000s focused on the need to significantly increase airspace system capacity with no compromise in safety. Specifically the stated goal was to triple airspace capacity (3X), no small order considering the National Airspace System (NAS) is fundamentally limited in capacity due, in part, to the reliance on human air traffic controllers to ensure traffic separation.

A relevant historical review of the origins of navigation and separation in IMC is provided in reference [6]. The review shows that the fundamental limitation in IMC operations that led to the current system of IFR under ATC control was lack of visibility in the clouds. Pilots could not see the ground to navigate, and so electronic navigation aids emerged which solved this problem but created another: a concentration of aircraft on prescribed “airways” and the associated collision hazard particularly at their intersections. Since aircraft could also not see each other in the clouds, ATC expanded its role from runway adjudication for arriving and departing traffic to also assist in separating en route aircraft. Initial use of so-called “procedural” separation methods were eventually replaced by radar, but over decades the role of ATC in managing en route traffic was institutionalized and largely has not changed. Today, with the advent of satellite precision navigation and air-to-air traffic surveillance via Automatic Dependent Surveillance Broadcast (ADS-B), the original cause for operational limitations no longer exists. It would not be a significant issue, except for the limitations still imposed on aircraft operators to accommodate the structure and needs of the ATC system that serves them. By and large, IFR aircraft are still concentrated onto airways and all still use ATC services for traffic separation. Emerging technologies do not appear poised to make a significant difference. Position broadcasts via ADS-B will soon be required of nearly all aircraft, but only to supplement and eventually replace the radar data source used for providing ATC services that will remain largely the same. Data communications will soon supplement and may eventually supplant the bulk of voice

Motivation

communications, but the capacity of the airspace system will still be restricted by the cognitive capacity of human controllers to track and communicate with each aircraft in their sector.

The primary motivators for the vision of airspace-user operational autonomy, defined here as *self-governance*, are these long standing inefficiencies imposed on IFR aircraft operators and the capacity limits of the ATC system [1]-[6]. Among its contributions, NASA produced a concept for introducing user operational autonomy into the airspace system that through its very name, “Autonomous Flight Rules,” invokes the proposed solution: create an additional formalized set of operating rules to complement VFR and IFR that is tailored to enable operational autonomy in IMC (similar to how VFR enables operational autonomy in VMC). In this concept, AFR flights will be non-segregated, sharing the airspace with IFR and VFR flights in “mixed operations.” Reference [9] details the AFR concept and how mixed operations would be enabled. References [6] and [9] discuss anticipated AFR benefits and their bases: improving safety, improving efficiency, reducing delay, increasing flexibility, lowering costs, and reducing implementation risk. Scalable capacity is achieved in AFR by removing the aircraft from the IFR system and the attendant ATC responsibilities for monitoring and separation. NASA’s research activities on “self-separation” and AFR, encompassing many studies, simulations, and human-in-the-loop experiments over a 12-year period, have answered many research questions including the scalable-capacity characteristic of AFR by demonstrating safe separation at traffic densities of 5x recent levels and above [10]. Mixed AFR-IFR operations studied from both the pilot and controller perspectives demonstrated operationally acceptable integration in shared airspace [11]. The overall finding from 12 years of research on AFR was a feasible concept of operations capable of meeting the significant challenge of achieving the growing capacity needs of the airspace system and the flexible operation needs of the aircraft operator community.

2.2. TASAR Motivation #1: Enable Future Operational Autonomy

As affirmative research findings of AFR accumulated, a critical question emerged: how do we get there from here? Certainly a significant rule-making effort would be required to codify the AFR rule set and establish performance standards for the enabling technologies. But what will motivate the industry to overcome inertia and initiate such efforts? An answer emerged in a realization that the technologies that enable AFR to benefit future airspace operators can also provide benefit to operators today. Non-safety-critical elements of the future technology could potentially be fielded to meet a current need, thereby getting the basic infrastructure in place. Over time, the technology would mature through operational use and likely expand to new applications, some of which may potentially track in the direction toward future operational autonomy. Reference [7] lays out such a potential roadmap to autonomy. A guiding principle of this roadmap is that each step along the way would be a beneficial and suitable end state, should the target goal of operational autonomy (i.e., AFR) or any preceding steps not be achievable. TASAR, envisioned as the first step in this roadmap, must hold to this principle as well. To be successful in initiating a transformation toward AFR, TASAR would need to be adopted by the community on its own merits. Its purpose, however, is to provide a real-world, current-day implementation of the technology and infrastructure needed for the future, thereby overcoming static inertia and nudging the industry forward. To understand this better, we go back to the technology of AFR to determine what exactly needs to be put in place.

With three operational rule sets available (VFR, IFR, and AFR), future aircraft operators will choose the rule set appropriate to their mission. The pilots must have the appropriate training and

Motivation

currency, and the aircraft must have the appropriate certified equipment and technology. For AFR, the technologies will be those that are key to enabling operational autonomy: traffic surveillance, information connectivity, and trajectory-management automation. The first two technologies are already emerging. Air-to-air traffic surveillance is available in the commercial market through an optional receiver upgrade to the mandated “ADS-B Out” transmitter system called “ADS-B In.” Such systems provide surveillance of nearby aircraft out to distances well over 100 nm (the size of a typical ATC sector). What is lacking are applications that sufficiently motivate aircraft operators to equip with ADS-B In. (As will be discussed, TASAR is intended as one potential motivation.) The second technology, information connectivity, is already a rapid-growth industry enabled by terrestrial and satellite airborne internet technology. This latest revolution in the industry is referred to as “connected aviation” and provides onboard automation access to virtually any online data content including key information relevant to airborne trajectory management (e.g., wind models, weather forecasts, restricted airspace schedules) [12].

The third technology enabling operational autonomy is airborne trajectory management automation, which does not currently exist in a form suitable for AFR. To enable AFR, this technology needs to perform three functions that would no longer be supplied by ATC: *monitor* the aircraft’s trajectory through the airspace, *detect* any need to change the trajectory such as a conflict, and *resolve* by computing one or more route modifications to meet the identified need. In operations where airspeeds are high, visibility is limited, and airspace constraints (e.g., weather hazards) may be evolving, these functions enabling operational autonomy in ever-increasing traffic density must be automated and not rely on a human to perform them. The requirement applies to all three functions (monitor, detect, and resolve). The monitoring function must be automated to ensure sufficient accuracy and notification time in predicting future events (e.g., a traffic conflict). The detection function must be automated to ensure vigilance that critical events are not missed. The resolution function must be automated to ensure a course of action is always available that best addresses the need. While these functions will all need to be automated to enable AFR, significant challenges remain in achieving the requisite functionality and safety criticality for use in dynamic, uncertain operational environments. The state of the art of such automation is a limiting function and will have to progress significantly before they will truly enable operational autonomy. TASAR can facilitate these advancements by providing early operational data and experience with an initial set of relevant automation functions in a non-safety critical application. Through everyday use in the dynamic airspace, TASAR offers the opportunity to mature the algorithms, refine requirements, and develop additional automation functions necessary to enable operational autonomy as envisioned by the AFR concept.

To enable research on AFR feasibility and performance, NASA developed a high fidelity prototype of this airborne trajectory management automation, the Autonomous Operations Planner (AOP) [13]. The functionality of AOP spanned from route optimization to separation assurance, the latter being the safety-critical function of self-separation required for AFR. NASA’s simulation research on AFR extensively exercised AOP, resulting in significant maturation and robustness of the software algorithms and infrastructure. Furthermore, thanks to an early design decision to pursue a high fidelity implementation, AOP was designed to integrate with onboard avionics using an industry-standard interface (i.e., ARINC 429). This key decision proved fortuitous for TASAR’s prospects for near-term technology transfer.

In summary, the first motivation for proposing TASAR (to induce a fundamental shift toward airborne trajectory management and future autonomy) centers primarily on the approach of

Motivation

fielding a viable current-day application of airborne trajectory management technology, one that leverages the conflict-free route optimization capabilities of AOP in a repackaged application called TAP. The strategy is one of technology insertion: use NASA technology transfer of TAP (an AOP derivative) as a catalyst to get pilots to acclimate to a new role as proactive trajectory managers with the modest, non-safety-critical goal of flight path optimization.

2.3. TASAR Motivation #2: Enhance Flight Efficiency

The second motivation for TASAR is simply to improve flight efficiency for today's airspace users while not impacting and potentially benefiting the air traffic controller. Tied in with this is the desire to incentivize ADS-B equipage. The following description excerpted from the original TASAR concept publication summarizes the motivation [14].

“Aircraft operating in the National Airspace System under IFR generally must fly trajectories approved by ATC. The approved trajectory is the trajectory originally specified in the flight plan or subsequent ATC clearance received prior to takeoff, modified by changes issued or negotiated and approved by ATC after takeoff and throughout the flight. The approved trajectory often does not coincide with the aircraft operator's most efficient or preferred trajectory. Less-desired trajectories can be the result of non-optimal routes, altitude restrictions, and/or speed restrictions issued by ATC before or during the flight, or of changing conditions or priorities during the flight. Some causes of in-flight priority changes are unanticipated weather convection or turbulence development, the need to make up time as a result of an earlier reroute to avoid traffic or weather, the need to delay arrival due to fleet operator constraints or traffic congestion at the destination, and the need to increase altitude as fuel is burned to improve efficiency. As a result, pilots occasionally have a need or desire to change their trajectory while in flight. The desired change may be a revised lateral route, a climb or descent to a different altitude, a change in airspeed, or a combination. It may be of a temporary nature, such as a heading change to avoid weather, or a long-term nature, such as a diversion to an alternate airport.

“Because ATC has responsibility to separate IFR aircraft, it maintains authority over the trajectories of all IFR aircraft in controlled airspace, and IFR pilots are not permitted to make changes to their approved trajectory without first receiving permission from ATC. The operational procedure to request a trajectory change is for the pilot to prepare the request and, when appropriate, communicate it to the air traffic controller. The controller will assess the request with respect to nearby traffic and other factors and issue an approval, an amendment, a deferral, or a denial. The pilot then proceeds as instructed.

“Referred to as ‘user requests,’ trajectory change requests from aircrews may not be living up to their full potential to provide user benefits. Traffic information is currently not available to most flight crews, and consequently, a trajectory change request has a reasonable chance of not being approvable by the controller because of resulting conflicts. Disapproved user requests are an operational detriment to everyone involved. They cost workload for the pilot and controller, contribute to radio frequency congestion, and do not produce a more desirable trajectory. In addition, conflict-free opportunities for improving the trajectory can remain undiscovered by pilots because of the lack of onboard traffic information and automation to compute trajectory changes that are more optimal.

“ADS-B has been established as a surveillance infrastructure that will provide substantial benefits to both airspace users and air navigation service providers in the future. The FAA

Motivation

(Federal Aviation Administration) has mandated that all aircraft operating in current Mode-C airspace be equipped with ADS-B transmit capability by 2020. System benefits increase with the number of aircraft equipped, so there is interest in increasing ADS-B equipage levels as quickly as possible, preferably long before the mandate takes effect. Therefore, near-term applications are sought that provide user benefits large enough to justify the cost of equipping aircraft with ADS-B capability. ADS-B provides an opportunity for airspace users to gain more utility from their trajectory change requests. Aircraft that equip with ADS-B receivers gain access to the key information – timely and accurate traffic surveillance – needed to formulate trajectory change requests that avoid other aircraft and therefore are more likely approvable by ATC.”

In summary, opportunities for increasing operational efficiency for today’s aircraft exist, and TASAR offers a means to act on those opportunities. Even if the goal of operational autonomy is never reached, these improvements in operational efficiency alone justify the pursuit of TASAR.

3. Concept Description

First conceived in 2005, published in 2012 [14] and 2013 [15], and patented in 2015 [16], the concept of TASAR (as described in the first publication)

“combines ADS-B and flight deck automation for in-flight decision-aiding and re-planning to increase the likelihood of ATC approval of pilots’ trajectory change requests, improving the efficiency or other user-desired attribute of the flight, while not impacting and potentially benefiting the air traffic controller. In addition to ADS-B surveillance, TASAR can leverage ground-based information services via data link or internet access, as well as on-board weather radar, to identify weather hazards to be avoided and other conditions affecting flight optimization and ATC approval” [14].

Embedded in this long-winded description are several key attributes of TASAR: ADS-B surveillance, on-board data sources, ground-based information services, flight deck automation, optimization, trajectory-change requests, and ATC approval. As illustrated in Figure 1, TASAR integrates these attributes into a progression: data flows into automation that optimizes trajectories which are requested and usually approved.

The TASAR concept is embedded in the three parts of its name: “Traffic Aware,” “Strategic,” and “Aircrew Requests.” Starting from the end, “Aircrew Requests,” the concept centers on the mechanism IFR pilots use today to modify their route: making requests to ATC. It is common practice for some pilots to make occasional route modification requests to sector controllers as they proceed en route to their destination. Apart from weather and turbulence avoidance, these requests are typically geared towards improving flight efficiency and are often based on rules of thumb. Pilots may ask for a “direct” i.e., a short cut directly to a downstream waypoint on their

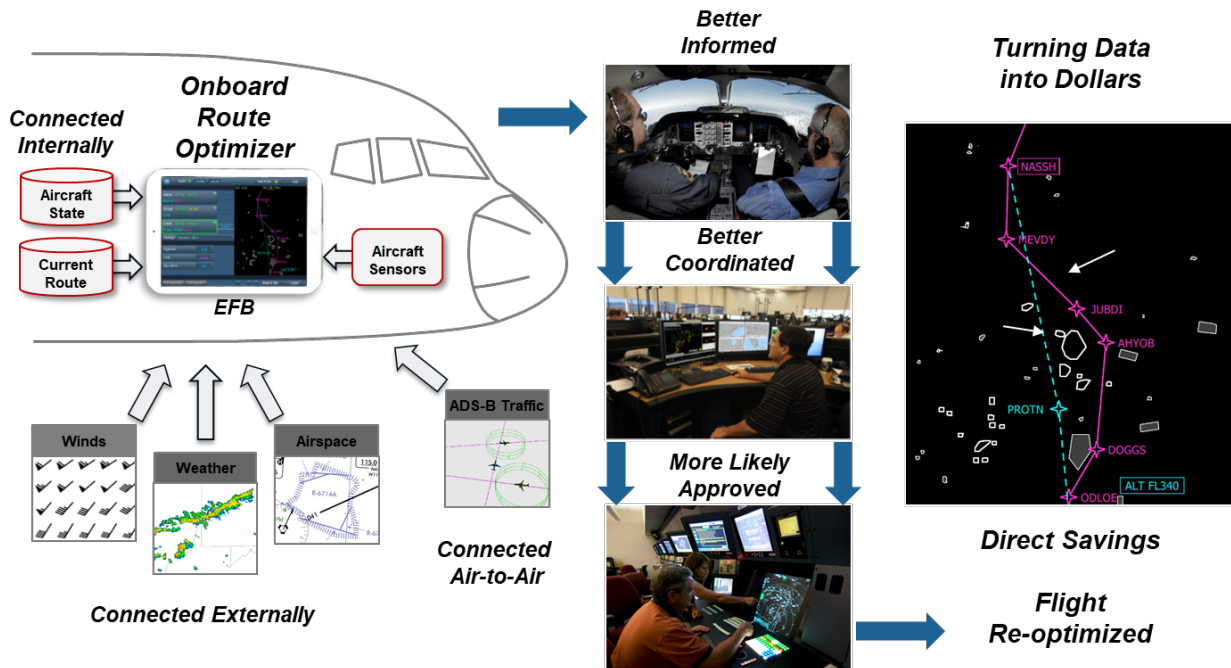

Figure 1. The TASAR concept.

Concept Description

filed route to achieve a shorter ground track and therefore presumably save time and fuel. Pilots of larger aircraft (e.g., airlines) may also ask for a change in altitude to a presumably more efficient (typically higher) altitude as the aircraft burns off fuel and becomes lighter. ATC generally grants these requests where local procedures allow, after checking first for conflicting traffic and other constraints. Using this request-check-approve mechanism, pilots can ask for pretty much any change to their route they want, within the practical limits of voice requests and pilot/controller workload. TASAR's aim is to leverage this existing mechanism and its flexibility but will augment it with trajectory management automation to more reliably enhance flight efficiency relative to rules of thumb that may not consider all of the information available through TASAR, for example, wind data at different altitudes on and off the current path.

The middle term, "Strategic," introduces the notions of a more informed view of the situation and a more purposeful aircrew request. Sometimes a tactical decision may seem counterintuitive until considered in the context of a strategic goal, for instance, a requested change from a direct route to a non-direct route, or a requested change to a lower cruise altitude instead of a higher cruise altitude. TASAR aims to empower an operator with a strategic goal (a re-optimized route) and the means to achieve it (technology designed to advise more optimal routing). A key element of TASAR is the retrieval, integration, and processing of large quantities of diverse, near-real-time data about the aircraft and its operating environment. This information processing is central to the strategic characteristic of TASAR in that it aids the pilot in finding the most optimal balance between objectives and constraints. The pilot's desire might be to know whether their aircraft is still on the best route that minimizes the operating cost for this flight, as was planned before departure hours earlier. Given that wind field models and weather forecasts are always being updated, even during the flight, the previously optimal flight plan may need to be re-optimized based on these updates and on conditions experienced in flight. TASAR opens up the opportunity to ensure the route modification request made to ATC achieves the operator's particular strategic goal for that flight (which may even change during the flight), even if it means making an occasional non-obvious and potentially counter-intuitive request. To this end, the advent of the "connected aviation" revolution currently unfolding in the industry is perfectly timed for enabling the Strategic (i.e., informed view) aspect of TASAR [12].

Finally, taking on the moniker of "Traffic Aware," TASAR is identifying with the needs of the "strategic aircrew request" approver – ATC. After all, finding the most optimal route modification possible means nothing if the sector controller cannot approve the change. Though many factors play into ATC approving a pilot's request, traffic separation is generally the most important factor. It is therefore in the pilot's best interest if nearby traffic can be considered when formulating the request. If left to chance, the request may be disapproved due to traffic, thereby delaying or potentially eliminating the opportunity for flight efficiency improvement. To that end, TASAR invokes the Traffic Aware characteristic as the principal example (but not the only example) of elements addressing ATC's requirements for approvability. A second example is active Special Use Airspace (SUA), through which ATC will generally not approve aircraft passage. As stated, many other such factors exist. The goal of TASAR is not to incorporate all such ATC approvability factors (many of which are not accessible or even codified). Indeed, the flight efficiency goal of TASAR seeks as much optimization as possible, which means not over-constraining the set of possible route options with ATC restrictions that may not always be applicable. Traffic separation is certainly mandatory, and thus it is given prominence in TASAR. It also meets the objective of providing aircraft operators a tangible benefit for ADS-B In equipage.

Concept Description

TASAR, therefore, is the concept of pilots using cockpit-based trajectory management technology, connected to an array of relevant data sources, to identify route optimization opportunities that may exceed the benefits achieved by pilots without this technology and that have improved likelihood of ATC approval thereby providing direct cost-benefit to the operator. The concept is formally defined in reference [15]. By “turning data into dollars,” TASAR’s direct product is operational savings, a useful feature in motivating industry to consider adopting the technology. Another such factor is that TASAR is designed as an advisory capability with no safety-critical function. This enables operators to install the TASAR automation on an Electronic Flight Bag (EFB), a burgeoning technology that is growing in popularity particularly when paired with “connected aviation” and the real-time access to onboard and off-board data it provides. The platform seems custom made for TASAR, though the reverse is more the case. Suppliers are rapidly producing “connected” EFBs and are looking for applications like TASAR to help make the business case.

The procedure for pilots to use TASAR is straightforward. They simply monitor the application during the flight for any displayed opportunity to optimize the flight. TASAR is expected to be used outside of terminal airspace during the climb (above 10,000 feet (ft) for jet aircraft operators) and cruise portions of the flight. For some installations, some set-up of the application is likely required with respect to the current flight plan, but this can be done on the ground before departure. Once the aircraft is airborne and the application is active, it will display route optimization opportunities when available. The pilot consults the application as desired and reviews the options presented. As is always the case, even without TASAR, any serious consideration of a route modification must include crew coordination, cross-checking with the onboard certified systems (e.g., Flight Management System (FMS), weather radar), and depending on company policy, coordination with a dispatcher. The request to ATC is made using normal procedures and phraseology without reference to “TASAR.” From ATC’s perspective, it is simply a user request. They are not trained on TASAR, and no operational credit is given that would result in special treatment.

Another TASAR procedure is to use the application to assess the merits of a route modification proposed by an external source, which could be the pilot, the dispatcher, or the air traffic controller. For instance, if ATC offers a “direct” clearance to a downstream waypoint, the pilot could quickly enter it into the application and assess whether the maneuver is indeed cost effective. Depending on the wind field, the answer may be no, and the pilot may wish to decline the offer.

The concept of TASAR as described here is a starting point, but future enhancements are envisioned as elements of the Next Generation Air Transportation System (NextGen) become operational. Such enhancements include incorporating four-dimensional (4D) constraints and degrees of freedom into the automation, integrating TASAR with Data Communications (Data Comm), augmenting TASAR with new data available through the System Wide Information Management (SWIM), and expanding the types of optimization beyond just time and fuel costs (e.g., turbulence minimization). These elements will be discussed further in Chapter 13, “Technology Transfer and Beyond.”

4. Project Approach

The TASAR project was initiated in February 2012 and concluded in July 2019. Sponsored primarily by the NASA Airspace Operations and Safety Program (AOSP), TASAR began under the auspices of the Concepts and Technology Development (CTD) Project through funding of two NASA Research Announcement (NRA) contracts, and it continued beyond these contracts under the Airspace Technology Demonstrations (ATD) Project. The TASAR project completed under the sponsorship of the Langley Technology Transfer Office.

Impelled by the motivations described in Chapter 2, the TASAR project was initiated with the principal objective of positioning NASA’s state-of-the-art airborne trajectory management technology for transfer to industry such that it would “stick.” In other words, for the technology transfer to achieve its near-term goal of enhancing flight efficiency for today’s airspace users, it would need to generate sufficient “pull” from the end users, be commercialized by industry suppliers, enter service in operational use, and be self-sustaining without NASA involvement. Furthermore, to achieve its long-term goal of enabling operational autonomy for future airspace users, it would need to inspire additional industry investment in creating derivative products that foster an evolution toward future operational autonomy. To increase the likelihood of success in such ambitious undertakings, a project approach was formulated around a five-point strategy, described in the following paragraphs.

1. Fill a current need

The emergence of the “connected aircraft” revolution and the expansion of EFBs beyond their original purpose of hosting static information (e.g., charts, manuals) created a need in the industry to demonstrate the profound possibilities inherent in this new platform, now connectable to the aircraft and the world. Any application that could create a business case for onboard computing and connectivity was in high demand, and not just by single industries. Driving this need were vendors from multiple industries: EFB hardware, avionics connectivity, terrestrial and satellite internet connectivity, navigation avionics, surveillance avionics, flight efficiency services, weather data services, and even airframe manufacturers.

Approach: The TASAR project would help establish a business case for the emerging “connected EFB” by developing a compelling software application for this revolutionary new platform. The software application would introduce a state-of-the-art *airborne trajectory management* function and a proactive role for pilots using it.

2. Demonstrate a clear business case

To enhance its commercialization potential, the software application should target a direct connection between the investment and its return. By enabling cockpit-based route optimization through TASAR, the investments in hardware, connectivity, and associated certification present a compelling business case centered on achieving direct operational cost savings for each flight. Such arguments are easier to make than building a business case on technologies that improve safety, which can often require a more circuitous argument to demonstrate a return on investment.

Project Approach

Approach: The TASAR project would focus the technology on achieving direct-operating-cost savings. The project would estimate the cost-savings benefit and make these preliminary estimates available to industry early in the project to promote interest and engagement.

3. Reduce risk of technology transfer

Introducing any new technology into an aircraft environment carries some additional inherent business risk as compared to ground-based technologies, given the extra burdens imposed by policy and regulation to ensure the safety of flight. Ultimately these burdens must be shouldered by companies that commercialize and market the products to their customers, not by NASA, who (in the case of TASAR) prototyped the technology and would license it to these commercial companies. However, NASA can take steps to lower the barriers to commercialization by studying key issues in advance and publishing the results, thereby reducing some of industry’s investment risk.

Approach: The TASAR project would conduct preliminary analyses of safety, human factors, and FAA authorization requirements. The project would conduct flight trials to validate the technology’s viability and robustness in real aircraft operating in the airspace system.

4. Bridge the valley

NASA typically works on the lower end of the TRL scale (Table 1) by inventing, prototyping, and demonstrating technologies to industry. The expectation is that industry will recognize the technology’s value and take it the rest of the way through the higher TRLs to eventually market the technology for operational use. However, many valuable NASA technologies with great potential have been lost in the “valley” between NASA’s low TRL investments and industry’s high TRL expectations, having never successfully negotiated a full handoff from one to the other. The TASAR solution is for NASA to reach a little higher on the TRL scale and to invite industry to reach a little lower, meeting in the middle to conduct a joint technology evaluation in a mutually relevant environment.

Table 1. NASA Technology Readiness Level scale.

		TRL Level	Qualifier/Development Hurdle
Typical NASA Research Focus	Basic Research	1	Basic scientific/engineering principles observed and reported
	Feasibility Research	2	Technology concept, application, and potential benefits formulated (candidate system selected)
	Feasibility Research	3	Analytic and/or experimental proof-of-concept completed (proof of critical function or characteristic)
	Technology Development	4	System concept observed in laboratory environment (breadboard test)
Technology Demonstration “Valley of Death”	Technology Development	5	System concept tested and potential benefits substantiated in a controlled relevant environment
	System Development	6	Prototype of system concept is demonstrated in a relevant environment
Industry System Development Focus	System Development	7	System prototype is tested and potential benefits substantiated more broadly in a relevant environment
	Operational Verification	8	Actual system constructed and demonstrated, and benefits substantiated in a relevant environment
	Operational Verification	9	Operational use of actual system tested, and benefits proven

Project Approach

Approach: The TASAR project would seek partner airlines to conduct operational evaluations of the technology in revenue service. Operational data from the evaluations would be used to validate the preliminary benefit estimates and provide justification for industry to carry it forward.

5. Promote industry investment in basic and derivative products

For the technology to be self-sustaining and grow in relevance, it must inspire further investment by industry or else risk being a static “spin off” technology with no future beyond its initial implementation. Ideally, a wide variety of companies would identify connections between their own product innovations and TASAR and pursue both together as a synergistic endeavor. This approach is more likely to be sustainable than one that attempts to build a new industry centered just on TASAR automation, at least at the outset. As TASAR was envisioned as a foundation upon which future capabilities could build, it is well positioned to attract such industry innovators.

Approach: The TASAR project would encourage companies to follow or participate in NASA’s activities, increasing awareness of TASAR as a foundation for technology innovation while creating an initial cadre of TASAR industry experts.

These five supporting objectives and their associated approaches drove the structure and content of the TASAR project. At the outset, it was unknown how far down this path the NASA effort would be able to reach. In fact, the initial project scope envisioned proceeding only as far as the first human-in-the-loop (HITL) simulation experiment and flight trial (FT). However, market research was simultaneously pursued to determine the level of interest in the industry for TASAR, and the immediate strong response confirmed that the larger objectives were achievable provided that no showstoppers emerged as a result of the earlier activities. Thus the following activities for the TASAR project were defined:

- Preliminary assessments (benefits, safety, FAA approval, market analysis)
- Technology prototype development
- Human factors simulations
- NASA flight trials
- Airline operational evaluation

Figure 2 shows the TASAR project timeline approximately as executed. The figure shows the rapid progression from concept development and analyses to prototype development, HITL simulations, and NASA FTs, to airline evaluation and commercial industry license applications. Also note the early and continuous engagement with various elements of the aviation community, initially to assess interest and later to communicate progress. Summary descriptions of most of these activities are provided throughout this report. Most activities are described in greater detail in previously published reports as will be indicated in each chapter. The summary descriptions in this report include unattributed text excerpts from these references.

The TASAR project team and resource expenditure varied significantly over the life of the project. While retroactively calculating the total cost of the TASAR project was not feasible given multiple complications (i.e., variable civil servant and contractor staffing levels, contract transitions, changes in sponsoring NASA project, blended work on TASAR and follow-on development, and heavy leveraging of industry company resources), a summary of personnel involvement is provided to give an indication of the scope of the TASAR project resources.

Project Approach

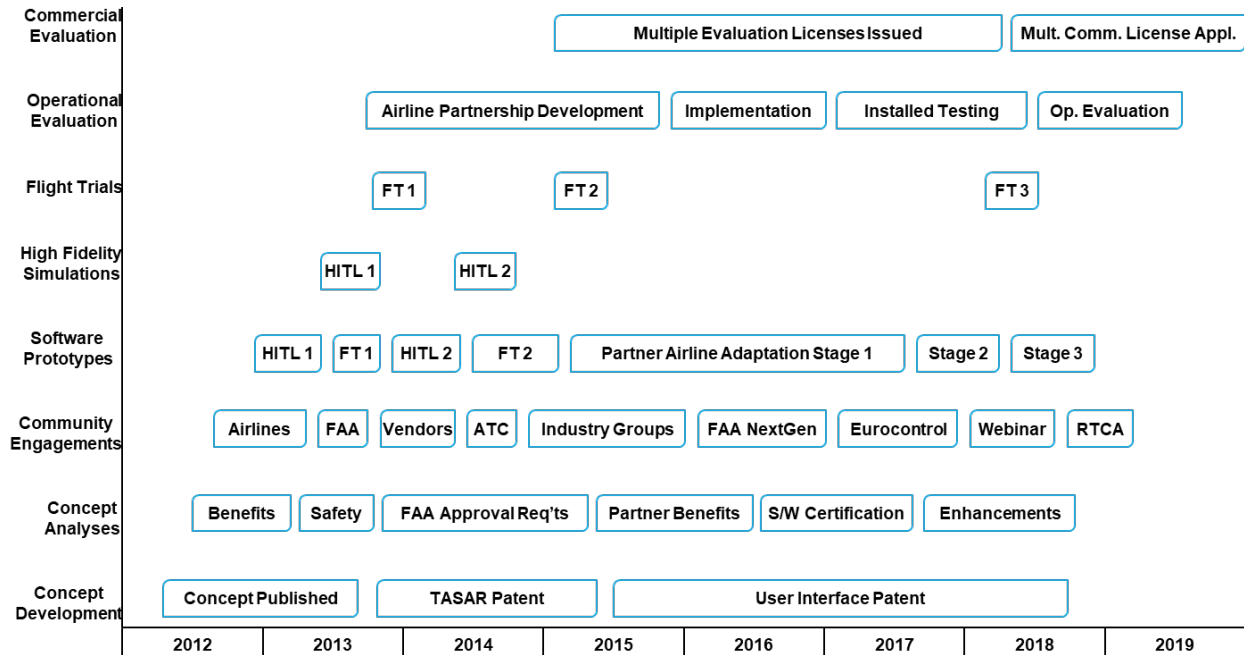

Figure 2. Approximate calendar-year timeline of the TASAR project.

The TASAR project relied heavily on contractors throughout its duration but especially for the first four years, from project initiation through the second NASA flight trial in 2015. The bulk of the TASAR workforce through 2015 was provided through two NRA contracts, described below. Only two civil servants (CS) were dedicated to TASAR – a principal investigator/project lead and a human factors scientist – with one to two others assisting on a limited basis. Once the airline partnerships were formalized in 2015, the CS team and contractor staff started to grow. Concurrently, the project switched sponsors from CTD to ATD, and the scope of work expanded beyond the airline operational evaluations to also include developing and testing the integration of NASA’s air and ground route optimization technologies. TASAR personnel supported both activities (TASAR and integration) in parallel until the integration work was suspended in late 2018. The peak year for the CS team working on TASAR (and integration) was 2017, with nine persons (not including management and other support personnel). Supporting the CS team throughout the project was an aviation-operations subject matter expert (SME) contracted through the National Institute of Aerospace (NIA) who facilitated extensive engagement between the NASA TASAR team and industry. Additional NIA SMEs supported the project at various stages.

Two NRA contracts were issued at the outset of the project, one to Engility Corporation and one to Rockwell Collins. The Engility contract focused primarily on TAP development and conducting NASA flight trials. The TAP software development team consisted of six persons, with two to three others on an in-house contract assisting as needed in configuration management and code delivery. Augmenting that team, a TASAR analyst produced the benefits assessment and supported data analysis for the flight trials. The first and second NASA flight trials were subcontracted to Advanced Aerospace Solutions, consisting of a four-person principal team with additional personnel supporting as needed. The subcontract included aircraft modifications and flight hours, and the Engility team augmented their staff by two persons to support data collection and analysis.

Project Approach

The second NRA contract to Rockwell Collins focused primarily on analyses of market interest, safety, and regulatory issues, as well as the design and execution of the two HITL simulation experiments. An avionics systems SME performed the several analyses, while the human factors simulations were subcontracted to the University of Iowa Operator Performance Lab (OPL). The simulation team consisted primarily of about four persons with four to six others supporting as needed.

By 2016, the NRA contracts had concluded, and all contracted efforts switched to in-house teams. The period leading up to the airline operational evaluation (2016-2018) had the largest TASAR team size, with up to 30 contractors providing some level of support (most of which was not full time). The CS team included seven to nine persons, though also mostly not full time on TASAR (e.g., some also supported air/ground integration). While not charging to the project, many additional NASA personnel also supported various TASAR activities (e.g. legal, contracting, software release, safety reviews). Significantly reducing NASA's cost burden, the industry participants brought their own resources to the project. The Alaska Airlines team included up to 15 persons at various stages and provided access to the aircraft and support personnel for testing and for the operational evaluation flights. Similarly, industry collaborators Collins Aerospace, Gogo Commercial Aviation, and Aviation Communications & Surveillance Systems each had about eight persons working at some level on TASAR and provided their own testing facilities and support personnel.

Other expenses for the project included hardware, data subscriptions, software products, in-house flight testing, and travel. NASA procured several pieces of avionics equipment to support bench testing and flight testing of the TAP software, as well as multiple computer systems, tablets, and network equipment dedicated to systems integration testing. A weather data subscription was procured for software prototyping and use in the operational evaluation. Additional software tools were procured to support training material development. A third NASA flight trial was procured using in-house personnel and aircraft. Travel included trips to industry forums, partner airline facilities, and conferences. All expenses were geared towards accomplishing the ambitious objectives of the TASAR project.

5. Benefits Assessment

Among the first priorities of the TASAR project, after defining the concept, was to generate a preliminary assessment of operational benefits. Not only would the assessment inform the NASA team on the various benefit mechanisms and the expected magnitude of savings, it would be a crucial element of NASA's outreach to industry. In fact, every airline and industry company with whom NASA discussed TASAR requested estimates of savings potential. Immediate credibility for both NASA and TASAR was gained by having these estimates in hand, as they showed that NASA was addressing an industry need and had the forethought to provide the estimates up front. Furthermore, the benefits assessment was instrumental in airline partnership development. Two airlines, Virgin America and Alaska Airlines, later used the NASA preliminary estimate as justification to enter into self-funded partnerships with NASA to conduct operational evaluations on their aircraft.

The TASAR benefits assessment was performed in two stages. A preliminary assessment was performed at the outset of the project exploring the benefits potential for a range of generic airspace user classes (network air carriers, low cost airlines, regional airlines, and business aviation operators) and providing an estimate of benefits per flight in terms of fuel burn and flight time metrics, as well as some additional ancillary metrics. Later, the methodology was extended to estimate the annualized benefits for the two prospective partner airlines. These estimates incorporated information about the airlines' fleet size, route structure, and flight frequencies, and it calculated estimates of benefits for the fleets assuming a specified number of aircraft were equipped and conducting TASAR operations for a year. The sections below summarize the objective, method, results, and conclusions of the benefits assessments. Full details can be found in references [17], [18], and [19].

5.1. Objective

The objective of the preliminary benefits assessment conducted at the project's outset was to quantify and characterize the potential benefits of TASAR for a range of aircraft operators. The questions at hand were, "who might benefit from TASAR, by how much, and under what circumstances?" Aircraft operations in the conterminous United States (CONUS) are highly diverse, and TASAR benefits are expected to vary accordingly. Flights can range from under one hour to more than five hours. Origins and destinations are major hubs for some flights and not for others, and airspace structure plays a greater or lesser role in the flexibility for rerouting, depending on location. Flights also vary by aircraft type, and weather and wind impacts vary geographically as well. The assessment would seek to characterize benefits across some of these factors. Also to be assessed were the effects of TASAR on ATC in terms of traffic conflicts and the effects of ADS-B equipage level on TASAR benefits.

Upon identification of prospective partner airlines, an additional objective was to estimate the annual cost savings for these airlines assuming a substantial portion of their fleets were equipped with TASAR.

5.2. Method

The assessment began with an analysis of TASAR opportunities and benefit mechanisms. Opportunities for aircrew requests were selected from requests that are relatively common in

Benefits Assessment

current operations as suggested by pilot and ATC SMEs. One constraint on requests is the practical use of voice communications, which limits route change requests to one or two named waypoints (i.e., navigational aids, fixes, and airway intersections) before rejoining the original trajectory downstream, since the voice communication frequency must remain available to ATC for time-critical clearances.

A preliminary quantitative analysis and a literature search were used to select three “use cases” of aircrew requests that are expected to have the highest potential for benefits. The analysis focused on quantifying the benefits of these three use cases of aircrew requests, recognizing that there are other use cases of aircrew requests that have opportunities for benefits. This analysis therefore represented only part of the expected full benefit of TASAR. The benefits of the following three use cases of aircrew requests were quantified:

1. An aircraft is part of an FAA reroute initiative to avoid convective weather or mitigate congestion. Aircraft in these initiatives are sometimes not shifted back to user-preferred routes after the initiative has ended. The aircrew requests a lateral trajectory change direct to a downstream waypoint or changing one or two named waypoints along the trajectory before reconnecting to the route upstream of the arrival fix.
2. An aircraft is impacted by convective weather, and there is sufficient lead time to the convective weather to allow a strategic route change rather than a tactical heading change. The aircrew requests a lateral trajectory change consisting of changing one or two named waypoints along the trajectory before reconnecting to the route upstream of the arrival fix.
3. The aircrew requests a trajectory change (lateral, altitude, or combination lateral and altitude) to switch to a more wind-optimal trajectory. This request for a more wind-optimal trajectory is intended to occur when the aircraft is not impacted by a reroute initiative or convective weather.

Historical days that contained reroute initiatives, severe convective weather, or were clear of reroute initiatives and convective weather allowing pure wind optimization were selected for the analysis.

A benefit mechanism is a causal link that converts a function into a benefit by applying the function to mitigate an inefficiency. Two TASAR functions were assessed, shown in Figure 3, generating user-preferred trajectories and pre-probing trajectories for traffic conflicts. The former mitigates the issue that the aircraft may not be following their preferred trajectory due to a previous inefficient trajectory assignment, a change in flight priorities, or a change in the environment (e.g., winds or weather). The latter is expected to mitigate the issue that aircrew requests are not always conflict free and are therefore sometimes denied by ATC.

The benefit mechanisms shown between the first and second vertical dashed lines are enabled by these two functions and result in the four benefits shown between the second and third vertical lines in Figure 3. The four benefits shown are: (1) the aircrew is better able to meet their objectives, (2) improved NAS performance, (3) reduced nuisance requests, and (4) reduced conflicts. In order to quantify these benefits, four metrics respective to the four benefits are (1) flight time per aircraft and fuel burned per aircraft, (2) NAS-wide effects such as delays, (3) aircrew requests rejected by controller, and (4) conflicts resolved by controller. The analysis quantified the first, third, and fourth metrics. While quantifying the second metric was beyond the scope and capability of the

Benefits Assessment

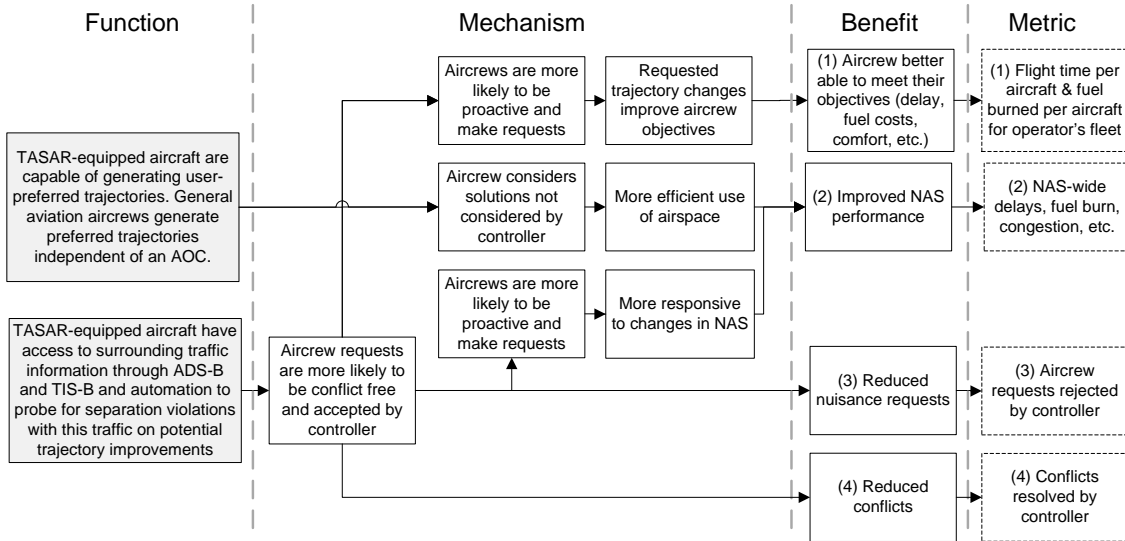

Figure 3. TASAR benefit mechanisms. From ref. [17].

analysis, NAS performance may have both positive and negative effects depending on the extent and nature of the technology's use.

A fast-time simulation platform described in reference [17] was used to conduct the benefit assessments. An existing simulation platform connected through an Application Programming Interface (API) to two instances of the Future ATM Concept Evaluation Tool (FACET) [20]: one to model the current state of aircraft trajectories, and the other to model future states of aircraft trajectories to test TASAR aircrew requests for conflicts with surrounding aircraft, conflicts with airspace hazards, and to calculate the impacts of TASAR aircrew trajectory change requests on user time and fuel objectives. The platform applied a series of nine models shown in Figure 4 and described in further detail in reference [17]. Models 1-6 represent the airborne side: model historical aircraft flight plans, synthesize aircraft trajectories, apply an ADS-B range limit, perform conflict detection on traffic and airspace hazards, generate alternate optimized routing, and formulate TASAR requests. The TASAR Request Model applied a series of seven filters to prevent making requests that would be considered unacceptable to the controller. Examples include cases in which the request conflicts with traffic or airspace hazards (SUA or weather), a previous request was made to the current sector controller, and the aircraft had passed an arrival fix within 200 nautical miles (nmi) of a large hub destination airport.

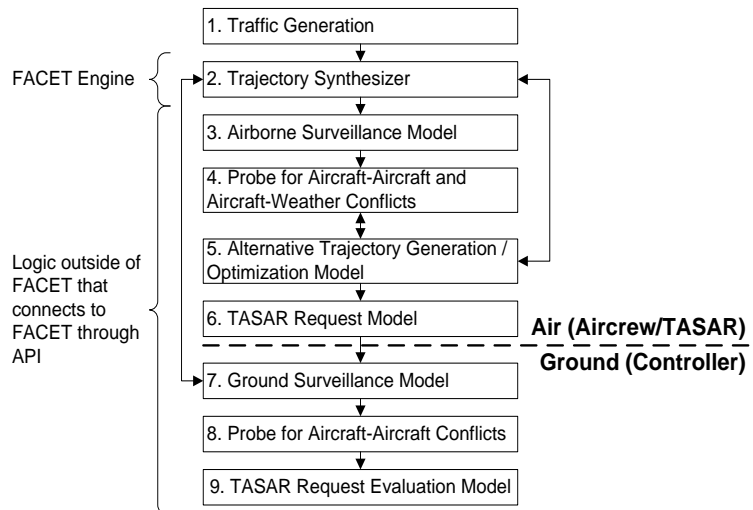

Figure 4. Models in TASAR simulation platform. From ref. [17].

Benefits Assessment

this final model, three primary filters were applied: the request would cause a traffic conflict, the request occurs in a sector that was experiencing traffic exceeding its monitor alert parameter value (i.e., a red sector), and the aircrew request was projected to enter an adjacent red sector. These last two filters intend to reflect the reduced flexibility available for granting rerouting requests in high-traffic sectors.

First, a preliminary analysis was conducted to estimate benefits per operation for several generic classes of operators. The preliminary results are based on analysis of approximately one week of traffic in July 2012. Method details are provided in reference [17].

Then, once prospective partner airlines were identified, additional assessments tailored the simulation to the specific airlines and extended the analysis to produce estimates of annual cost savings due to TASAR for majority fleet equipage. The annualized results are based on an extrapolated analysis of approximately three months of traffic in July through September 2012 and published airline-specific data detailing the annual frequency of operations between airport pairs by aircraft type [21]. Benefits are a function of both the benefit per operation and number of operations. Annual operations were divided by the number of aircraft of each type to obtain the number of operations per aircraft. Simulations of each airline's flights between their primary city pairs produced the benefit per operation for each of the three use cases of requests (reroute initiative recovery, reroute for convective weather, or reroute for optimal winds). Benefits were scaled based on the observed frequency of each request use case and summed to produce an annual estimate of fuel and time savings. Annualized cost savings were then estimated by applying the published fuel, maintenance, and depreciation costs for each airline to the fuel and time savings. Though additional savings in crew costs are expected, these costs were not included in the analyses. Method details are provided in references [18] and [19].

5.3. Results

5.3.1. Preliminary Benefits Analysis

Scenarios were selected for simulation based on classifications of airport hub size and stage length to represent typical operations for different classes of NAS users. Published data from four classes of airspace users were analyzed to determine the percentage of traffic by type of operation (e.g., origin and destination hub types, stage length). The four classes were network carriers, low-cost carriers, regional carriers, and business aircraft. For reference, Virgin America is classified as a low-cost carrier, and Alaska Airlines is classified as a network carrier. For the simulation, airport pairs were selected that were representative of the airport hub size and stage lengths of the four classes of operators. The preliminary results are based on analysis of approximately one week of traffic in July 2012. Three aircrew objectives are considered in this analysis: (1) minimize time, (2) minimize fuel, and (3) weighted combination of minimizing time (50 percent) and minimizing fuel (50 percent). This analysis also attempted to determine whether stage length, airport size, or use case of request (reroute initiative recovery, reroute for convective weather, or reroute for optimal winds) determines which aircraft would receive the highest benefits from TASAR.

Figure 5 shows the average time savings for an aircrew minimizing time per aircraft (y-axis) relative to a baseline without TASAR plotted against stage length (x-axis) for different airport sizes (separate curves). Aircraft traveling between large hub airports (shown as a solid black line) saved approximately 1.5 minutes of time at a 600 nmi stage length and these savings increased to approximately eight minutes at 2000+ nmi stage lengths. This trend of increasing time savings as

Benefits Assessment

stage length increases also held for the other airport sizes, but the slope is not as steep as the solid black line for aircraft traveling between large hub airports. Plots of average time savings when minimizing fuel and weighted combination of time and fuel objectives showed similar trends, as did plots of average fuel savings for the three types of objectives considered in this analysis. An additional analysis of two city pairs (shown in boxes in Figure 5) determined that the cause of the difference between time savings between large hubs (ORD-LAX) and between a medium and a large hub (PDX-ORD) related to a greater spread of historical trajectories for the former, which allowed more opportunities for savings.

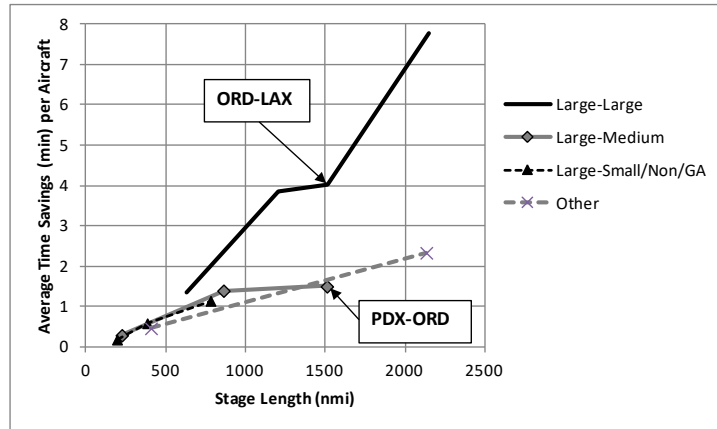

Figure 5. Average TASAR time savings by stage length and airport size. From ref. [17].

Figure 5 shows the average time savings for aircraft traveling between large hub airports (ORD-LAX) and between a medium and a large hub (PDX-ORD). The ORD-LAX line shows a much steeper increase in time savings as stage length increases compared to the other categories, particularly at longer stage lengths.

Simulation results described in reference [17] showed that there were higher time savings during convective weather conditions as compared to a condition where aircraft are requesting wind-optimal trajectories in the absence of convective weather and reroute initiatives. An insufficient number of flights were involved in cancelled or expired initiatives on the selected historical flight days to obtain an estimate of time savings for TASAR requests after a reroute initiative is cancelled or expired.

Some aircraft in the simulation experienced benefits much higher than the average. Figure 6 shows the distribution of time savings for aircraft that traveled between DFW and LGA (either direction) to meet the objective to minimize time. Each bar represents the count of aircraft (y-axis) with the time savings (x-axis). Even though several aircraft did not benefit (0 time savings), there were aircraft that experienced as much as 13 minutes of time savings. The aircraft with larger improvements had less efficient historically flown trajectories as compared to aircraft that did not benefit. The distribution in Figure 6 shows three characteristic regions: no benefit (0 time savings), moderate benefit (~3 minutes savings), and large benefits (7+ minutes savings). These characteristic regions were also seen in the Alaska Airlines operational evaluation as will be discussed in Chapter 12.

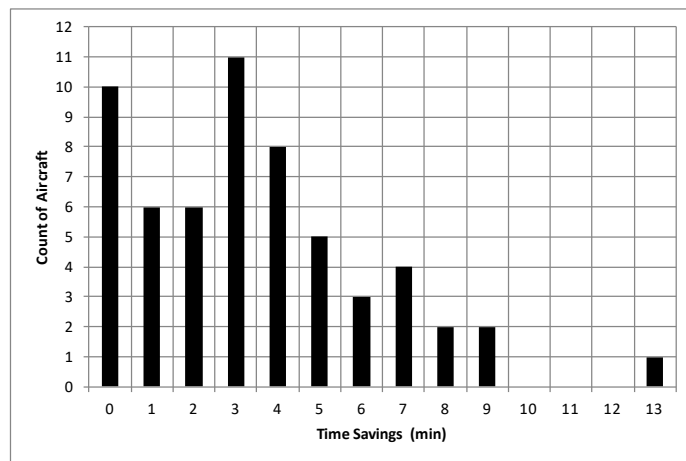

Figure 6. TASAR time savings for aircraft traveling between DFW and LGA. From ref. [17].

An initial calculation of the expected per-operation benefits (i.e., savings per flight) of equipping with TASAR is shown in Table 2. The calculations were achieved by mapping the benefits measured for each of 12 representative city pairs (representing different combinations of origin-

Benefits Assessment

destination airport types and stage lengths) to the percentage of operations by the four classes of airspace user (network carriers, low cost carriers, regional carriers, and business aircraft) to these city pair types. The methodology and intermediate data are presented in more detail in reference [17].

Operators typically use a weighted time-fuel objective in flight planning (known as Cost Index), and so the 50TF columns may be the most representative of

average TASAR savings per operation. The analysis results in Table 2 indicate that network carriers would save an average of approximately 3.6 minutes of time per operation and 543 pounds (lbs) of fuel per operation when minimizing a weighted time and fuel objective. This benefit was higher than the other airspace user classes due to network carriers operating at longer stage lengths between large hub airports than the other airspace user classes. Other airspace user classes benefited by about one to three minutes per operation and 50 to 340 lbs of fuel per operation. These estimates include flights that did not receive a TASAR benefit.

The preliminary benefits assessment also investigated additional metrics. An analysis (detailed in reference [17]) considered the impact of TASAR on traffic conflicts requiring ATC resolution. There is no expectation that TASAR would increase or decrease conflicts to be resolved by the controller, since TASAR (in this simulation) only checks for conflicts on potential trajectory changes to an eight minute look-ahead time horizon, and TASAR does not probe for conflicts beyond that time horizon. However, there is a concern that TASAR requests may inadvertently result in more conflicts for controllers to resolve beyond the eight minute look-ahead time horizon. An analysis indicated that average conflicts per aircraft for aircraft equipped with TASAR were lower than the baseline without TASAR for all three types of aircrew objectives (time, fuel, and 50/50 weighted). The TASAR requests in the simulation reduced conflicts to be resolved by the controller beyond the eight minute look-ahead time by shifting aircraft to altitudes with a lower traffic density. Depending on actual traffic density distribution by altitude, the opposite effect could also be possible. Though certain effects like favorable winds may cause local density to increase as aircraft seek out the same efficient routes and altitudes, TASAR also can serve to diffuse local density by providing pilots a means to adjust their requests based on nearby traffic. Determining the net effect with high levels of TASAR equipage was not possible with this simulation platform.

Three additional analyses can be found in reference [17], including the effect of ADS-B Out equipage levels on TASAR performance, the percentage by request type (lateral, vertical, combination) of approved requests, and request disposition (requests preempted by TASAR, approved requests, and rejected requests) as a function of stage length. The ADS-B Out equipage analysis indicated that TASAR benefits are immediately achievable under low levels of ADS-B Out equipage, but the finding is no longer relevant given the mandate date of 2020 has effectively

Table 2. Model-based estimate of TASAR savings per operation. From ref. [17].

Class of Airspace User	Time Savings (min)			Fuel Savings (lbs)		
	TO	FO	50TF	TO	FO	50TF
Network	4.2	3.4	3.6	-122	575	543
Low Cost	2.9	2.5	2.6	-123	406	344
Regional	1.0	0.8	1.0	-88	137	66
Business	1.2	1.6	1.5	- 2	64	53

TO = time objective, FO = fuel objective,
50TF = weighted 50% time 50% fuel objective.

Benefits Assessment

arrived. The simulation results indicated that combined lateral/altitude requests were an important source of TASAR benefits. The request disposition analysis showed a relatively low percentage of TASAR requests were rejected at all stage lengths and, when a beneficial trajectory change was found by TASAR, approximately half of these beneficial requests were not made due to TASAR determination of operational unacceptability and the other half of the beneficial requests were approved. In other words, TASAR was effective in making user requests productive for both the aircrew and ATC. This result does not reflect the other reasons ATC rejects requests not represented in the simulation, such as requests that would violate letters of agreement between ATC facilities.

5.3.2. Partner Airline Annual Benefits Estimate

The Virgin America analysis focused on operations of the Airbus A320 and A319, as both are candidates to be equipped with TASAR. Similarly, the Alaska Airlines analysis focused on the Boeing models 737-900ER, 737-900, 737-800, and 737-700. A total of 1,554 historical Virgin America flights and 1,606 Alaska Airlines flights in July, August, and September 2012 were analyzed using the fast-time simulation platform to estimate TASAR benefits. Published data on annual operations per aircraft for prominent city pairs (23 city pairs for Virgin America, 14 city pairs for Alaska Airlines) [21] were then applied to estimate the benefit for all flights between each city pair derived from the three TASAR request use cases (reroute initiative recovery, reroute for convective weather, or reroute for optimal winds). Benefits were then summed to produce the estimated total annual fuel and time benefits for each aircraft type, shown in Table 3 and Table 4.

Table 3. Virgin America estimated annual TASAR benefits by aircraft type. From ref. [18].

Aircraft Type	Annual Benefit Cancelled Initiative Use Case (1)		Annual Benefit Weather Use Case (2)		Annual Benefit Wind Use Case (3)		Annual Benefit Total (1)+(2)+(3)	
	Fuel (Gal)	Time (Min)	Fuel (Gal)	Time (Min)	Fuel (Gal)	Time (Min)	Fuel (Gal)	Time (Min)
A320	1273.9	123.0	1635.5	131.2	24700.3	2290.2	27,609.7	2544.4
A319	195.5	62.2	2628.6	164.3	22789.5	2458.0	25,613.6	2684.5

Table 4. Alaska Airlines estimated annual TASAR benefits by aircraft type. From ref. [19].

Aircraft Type (737)	Annual Benefit Cancelled Initiative Use Case (1)		Annual Benefit Weather Use Case (2)		Annual Benefit Wind Use Case (3)		Annual Benefit Total (1)+(2)+(3)	
	Fuel (Gal)	Time (Min)	Fuel (Gal)	Time (Min)	Fuel (Gal)	Time (Min)	Fuel (Gal)	Time (Min)
-900ER	568.4	53.7	271.4	15.3	11202.7	1312.2	12042.5	1381.2
-900	30.2	2.9	72.5	2.7	10464.5	1163.6	10567.2	1169.2
-800	528.3	50.6	149.0	21.3	8286.0	905.2	8963.3	977.1
-700	207.9	7.6	459.0	32.7	11612.0	1002.1	12278.9	1042.4

To estimate annual cost savings, published values for fuel, maintenance (Maint.), and depreciation (Depr.) costs [21] were applied to the annual fuel and time benefits (rounded down)

Benefits Assessment

of each aircraft by type, multiplied by the number of aircraft in each fleet, and summed. The calculations shown in Table 5 and Table 6 indicate that both airlines would save approximately \$5 million per year, based on aircraft counts, operations, and prices indicated for the year of the analysis.

Table 5. Virgin America estimated annual cost savings from TASAR. From ref. [18].

Aircraft Type	Number of Aircraft of Type	Annual Fuel Savings per Aircraft (Gal)	Fuel Cost	Fuel Cost Savings for All Aircraft of Type	Time Savings per Aircraft (Min)	Maint. Cost per Min.	Maint. Cost Savings for All Aircraft of Type	Depr. Cost per Min.	Depr. Cost Savings for All Aircraft of Type
A320	43	27,000	\$3.03	\$3,517,830	2,500	\$5.51	\$592,325	\$0.54	\$58,050
A319	10	25,000	\$3.03	\$757,500	2,600	\$5.68	\$147,680	\$0.54	\$14,040
Sum				\$4,275,330	Sum		\$740,005	Sum	\$72,090
Total estimated annual cost savings								\$5,087,425	

Table 6. Alaska Airlines estimated annual cost savings from TASAR. From ref. [19].

Aircraft Type (737)	Number of Aircraft of Type	Annual Fuel Savings per Aircraft (Gal)	Fuel Cost	Fuel Cost Savings for All Aircraft of Type	Time Savings per Aircraft (Min)	Maint. Cost per Min.	Maint. Cost Savings for All Aircraft of Type	Depr. Cost per Min.	Depr. Cost Savings for All Aircraft of Type
-900ER	22	12,000	\$3.26	\$860,640	1,300	\$8.44	\$241,384	\$8.72	\$249,392
-900	12	10,000	\$3.26	\$391,200	1,100	\$8.44	\$111,408	\$8.72	\$115,104
-800	61	8,000	\$3.26	\$1,590,880	900	\$4.96	\$272,304	\$6.75	\$370,575
-700	14	12,000	\$3.26	\$547,680	1,000	\$21.40	\$299,600	\$7.18	\$100,520
Sum				\$3,390,400	Sum		\$924,696	Sum	\$835,591
Total estimated annual cost savings								\$5,150,687	

Two additional analyses were performed to estimate the impact on ATC workload regarding request approvability based on traffic conflicts and peak number of requests per sector per hour. Method details are described in references [18] and [19]. The simulation results indicated that without TASAR, ~23 percent of requests would reasonably be expected to be rejected, whereas with TASAR, ~6 to 8 percent of requests would reasonably be expected to be rejected. The reduction is attributed to TASAR filtering out or adjusting requests to avoid creating traffic conflicts. The rejection rate does not reach zero because ATC has access to intent information, whereas TASAR had access only to traffic state information from ADS-B In.

Requests per hour by sector were approximated by binning the TASAR request times into hours and scaling by requests per day. Virgin America hourly results for the three sectors with the most requests indicated that 2 to 4 requests per sector occurred during the peak hours between about 9 AM and 2 PM. Alaska Airlines hourly results for the four sectors with the most requests indicated that 4 to 8 requests per sector occur during the peak hours of about 8 AM, 2 PM, and 9 PM. Given the simulation's limitations, these estimates indicate that even with fleet-level TASAR equipage,

Benefits Assessment

the impact on ATC workload may be relatively minor provided that TASAR requests do not require substantially more effort for ATC to manage than non-TASAR requests.

5.4. Conclusions

The preliminary benefits assessment conducted at the project's outset showed that all classes of airspace users gained benefit from TASAR. On average, aircraft equipped with TASAR, relative to aircraft not equipped with TASAR, saved about one to four minutes of flight time per operation and about 50 to 550 lbs of fuel per operation depending on the objective of the aircrew (time, fuel, or weighted combination of time and fuel), class of airspace user (network, regional, low cost, or business), and aircraft type (e.g., 737-800). These initial results were based on aircrews requesting lateral only, altitude only, and combination lateral and altitude trajectory changes. The use of combined lateral and altitude trajectory changes provided significant time and fuel benefits since approximately 30–50 percent of approved requests in the simulation were combination requests.

The analysis indicated that, in general, TASAR benefits increased with longer stage lengths since beneficial trajectory changes can be applied over a longer distance. Also, larger benefits were experienced between large hub airports as compared to other airport sizes. This was largely due to less efficient (from an airspace user point of view) historically flown trajectories between large hub airports, and not all flights operating to or from medium hub or smaller airports have significant room for improvement.

The two prospective partner airlines, Virgin America and Alaska Airlines, were each estimated to save approximately \$5 million per year if a significant portion of their fleets were equipped with TASAR.

The assessment also indicated no significant adverse impacts on ATC and some possible benefit. TASAR requests were found to reduce conflicts that controllers need to resolve beyond the look-ahead time horizon that TASAR was probing for conflicts. This reduction in conflicts was the result of aircrews in the simulation requesting altitudes with lower traffic densities. Results also indicate that TASAR improved productivity of user requests, with a significant number of unapprovable requests filtered out by TASAR's conflict probing and the great majority of requests made being approved. Peak hourly requests per sector for fleet-level TASAR equipage were estimated to be 8 or fewer requests for highest impacted sectors.

6. Safety Assessment

According to FAA policy on EFBs, “in order to qualify as an EFB application, the failure effect must be considered a minor hazard or have no safety effect” [22]. In anticipation that operational approval of TASAR may be predicated on a safety effect determination by the FAA, a preliminary Operational Safety Assessment (OSA) was performed with the intent to generate artifacts that may be useful for such a determination. Reference [23] details the preliminary OSA for TASAR. A summary is provided in this chapter. The OSA results support a likely Failure Effects Classification (FEC) of “No Effect” and no higher than a “Minor” effect. Any official determination of safety effect, if needed, would be made by cognizant FAA organizations responsible for authorization of EFB applications.

In the case of the two prospective partner airlines, a separate determination of safety effect was not required by the Principal Operations Inspector (POI) of either airline. The POIs authorized TASAR as an EFB application and documented the authorization in both airlines’ Operations Specification A061, “Use of Electronic Flight Bag,” listing the NASA TAP software application by name.

6.1. Intended Function

An OSA begins with a description of the “intended function” of the system. As presented in reference [23], the TASAR system is “an optional, advisory-only decision support tool that recommends trajectory change improvement opportunities to the pilot for operational efficiency improvements to flight operations. As such, TASAR is supplemental equipment, does not replace any required avionics function, and should not be on or alter the Minimum Equipment List for flight operations. Use of TASAR is at the discretion of the pilot, i.e., the pilot may choose to ignore TASAR or can manually inhibit its operation at any time for any reason.” In addition, TASAR provides no “operational credit” (i.e., authorization to operate beyond the operations authorized without the technology) and does not alter pilot or ATC procedures or requirements for making trajectory changes under IFR.

6.2. Methodology

The TASAR preliminary OSA methodology was based on two industry standard safety assessment methodologies to make a preliminary determination of the FEC for TASAR.

Method 1: Failure Effects Classification

References:

- Aviation Recommended Practice 4761 “Guidelines and Methods for Conducting the Safety Assessment Process on Civil Airborne Systems and Equipment” [24]
- Advisory Circular (AC) 25-1309 “System Design and Analysis” [25]
- AC 23-1309 “System Safety Analysis and Assessment for Part 23 Airplanes” [26]

Summary Description of Method:

1. Evaluate the intended function per phase of flight
2. Identify failure events

Safety Assessment

3. Examine the effect of these failures on aircraft, pilot / flight crew, and ATC
4. Determine the Hazard Classification, e.g., Major, Minor, No Effect
5. Determine frequency of occurrence, e.g., per flight hour, per operation
6. Provide rationale for hazard assessment

Method 2: Operational Safety Analysis

Reference:

- RTCA DO-264 / EUROCAE Document 78A “Guidelines for Approval of the Provision and Use of Air Traffic Services supported by Data Communications” [27]

Summary Description of Method:

1. Perform an Operational Hazard Assessment
 - 1.1. Identify Operational Hazards
 - 1.2. Determine the Operational Effect, the worst credible outcome of the Operational Hazard, e.g., collision, loss of separation, workload
 - 1.3. Determine the Severity Classes for each Operational Effect (Catastrophic, Major, Minor, etc.) and identify the maximum allowable probability of occurrence of the Operational Effect
 - 1.4. Determine the Effects Probabilities, which represent the probabilities of available mitigations to the system to help reduce the probability of occurrence of the Operational Effect due to the Operational Hazard
 - 1.5. Assign Safety Objectives, which represent the probability of occurrence of each Operational Hazard that is allowable for ensuring the safety of the application
 - 1.6. Identify External Mitigation Means, i.e., barriers external to the application that reduce the adverse effects and impact to safety when Operational Hazards occur
2. Allocate Safety Objectives and Safety Requirements
 - 2.1. Identify Abnormal Events and Basic Causes internal to the applications that could lead to the occurrence of each Operational Hazard
 - 2.2. Identify Internal Mitigation Means, i.e., barriers internal to the application that reduce the probability of the Operational Hazard from occurring in order to achieve the required Safety Objective
 - 2.3. Allocate Safety Requirements to the sub-functions comprising the application

Method 1 represents the traditional safety process for airborne systems and equipment. The key outcome of this safety assessment process is the determination of the FEC of the intended application (e.g., TASAR). The FEC then drives the development and validation requirements and processes to be followed in integrating the application into the flight deck to gain certification and operational approval.

Safety Assessment

Method 2 represents a system-of-systems analysis approach and is well-suited for allocating safety requirements across a high-criticality, multiple-system function. This allows a more balanced allocation of safety requirements across systems and sub-systems, which is particularly beneficial for higher criticality systems. While an excellent approach for systems analysis, it is not as well suited for lower criticality systems such as TASAR. This is particularly true in the realm of “Minor” criticality systems, where this approach puts excessive emphasis on formal analysis related to operational effects such as workload.

Given the likelihood of a low safety concern for TASAR based on SME input, the preliminary OSA for TASAR was essentially a qualitative decomposition of the concept and identification of potential hazards and mitigating factors. The analysis was performed by a systems analyst / safety and certification SME at Rockwell Collins, Inc. under contract to NASA, with input from additional SMEs in airspace and aircraft operations. No quantitative analysis was performed for the preliminary OSA. Reference [23] details the preliminary OSA performed for TASAR.

6.3. Analysis and Conclusions

The following sections highlight some of the identified hazards and mitigating factors relevant to TASAR.

Identified Hazards

- Pilot error entering TASAR configuration inputs, leading to non-functional TASAR software or erroneous TASAR system outputs
- Excessive pilot workload in entering or updating TASAR configuration inputs
- TASAR processing errors resulting in undetected misleading information displayed to pilot, e.g., fuel and time savings when the opposite would actually occur
- Ownship and/or traffic information (e.g., state, intent information) are incorrect or incomplete, leading to route modification candidates that have a conflict, but are presented as conflict free
- Wind data are of poor quality or are incorrect, leading to route modification requests that are conflicted or lead towards hazardous airspace
- Convective weather information is of poor quality or is incorrect, leading to route modification requests toward hazardous airspace
- Airspace status information is incorrect, leading to route modification requests toward hazardous airspace
- Detected errors, failures, or poor quality TASAR recommendations, leading to pilot troubleshooting and therefore additional workload
- Undetected errors or failures of TASAR computations, leading to poor or multiple route change requests and additional pilot or ATC workload
- Undetected errors or failures of TASAR computations, leading to hazardous encounters with traffic, weather, terrain, SUA, etc.
- TASAR application preoccupies the pilot from observing non-TASAR flight-deck hazard alerts
- Pilot misinterprets TASAR recommendation and unknowingly requests a trajectory clearance that is not conflict free or leads toward hazardous airspace
- TASAR misleads or confuses pilot who misrepresents TASAR recommendation to ATC

Safety Assessment

- Pilot follows the wrong trajectory clearance following receipt of amended clearance from ATC

Mitigating Factors

- TASAR is a supplemental system not relied on by critical functions supporting aircraft operations
- TASAR is optional and can be ignored or disabled without adversely affecting operations
- TASAR can be manually inhibited or ignored by the pilot at any time for any reason (e.g., detected failures, spurious or inconsistent system performance, distracting effects)
- Discontinued use of TASAR involves no recovery time since the aircraft remains on an ATC-cleared trajectory at all times. In the event of a TASAR system fault, the pilot need only remain on the current clearance while disregarding the TASAR display.
- TASAR is intended for use in non-critical phases of flight (i.e., above 10,000 ft for jet aircraft operators)
- The pilot has a responsibility to evaluate TASAR-provided route modification candidates before making a request to ATC, providing cross-check opportunities to detect erroneous candidates being offered by TASAR
- Certified aircraft systems (e.g., FMS, weather radar) serve as available, higher integrity information allowing quick check on acceptability and performance impacts of TASAR recommended route modifications
- Undetected, misleading information associated with TASAR outputs are mitigated by pilot inspection of the recommended route modification using standard procedures and certified systems and by mitigations associated with the existing route modification request process
- Route modification request procedures are unchanged; pilot must direct all route modification requests to ATC using conventional means and phraseology
- ATC is responsible for reviewing request for acceptability, including separation from traffic

The preliminary OSA for TASAR supported a likely FEC of “No Effect” and no higher than “Minor Effect,” the latter being identified in terms of a potential effect on pilot workload. The safety assessments performed for TASAR were preliminary and not exhaustive or authoritative as they were intended only to be investigative in nature and potentially serve as supplemental material for an official determination of the FEC, should one be required by FAA officials. Such determinations are typically only performed for an actual application by an operator to the FAA for operational approval, and only at the discretion of the approving official (e.g., an airline’s FAA POI). However, to assess the likelihood of TASAR being approvable as an EFB application, the NASA team met with the FAA authors of EFB policy in the offices of Aircraft Certification (AIR), Flight Standards (AFS), and Surveillance & Broadcast Services (SBS). Their feedback was fully consistent with the conclusions above, stating that TASAR should be viewed as a “Minor Effect” application because of potential pilot workload associated with TASAR due to misleading/bad data. From a loss-of-function standpoint, they viewed TASAR as having “No Effect” on safety. Formal determination, if needed, would again be left to the appropriate approving official.

The preliminary OSA was performed based on the TASAR concept represented by an early prototype of the TAP software which contained a sparse display of graphical information only

Safety Assessment

featuring the current route and the advised route modification. Early TAP evaluation pilots indicated that interpretation of TAP route modification recommendations absent of associated contextual information, in particular the weather polygons and SUA polygons accounted for in the route modification recommendation, was potentially problematic. Therefore a subsequent generation of the TAP Display incorporated the display of polygons to aid the pilot's understanding of the advisories. This raises the question of whether hazardously misleading weather information could be presented via the TAP Display, which in turn has implications on the Design Assurance Level (DAL) of the software. Further discussion of these issues is included in the next chapter.

7. Authorization Assessment

As with any new system installed on an aircraft, adherence to appropriate FAA standards will be required for TASAR. To determine which standards are applicable to an EFB application with TASAR's intended function, a requirements analysis for FAA authorization was performed. At the outset of the analysis, it was unclear how involved the requirements would be, and so the scope of the activity included drafting a project-specific certification plan, collecting representative artifacts, and conducting a "dry run" with Designated Engineering Representative (DER) certification officials. Ultimately these were not required by either Virgin America or Alaska Airlines to receive formal operational approval for TASAR from their POIs. A likely contributing reason a formal certification process for TASAR was not needed was the separation at both airlines of the EFB system approval from the TAP EFB application approval. Virgin America's EFB hardware system (Class 3, fully integrated with the aircraft) was already installed and approved when their association with the TASAR project began, and that installation was already approved for higher-criticality applications than TASAR (i.e., Major Effect). Alaska Airlines was already using the iPad as a standalone Portable Electronic Device (PED) EFB (i.e., Class 1, not electronically integrated with the aircraft) and had plans to upgrade to a "connected" PED EFB (i.e., Class 2, with "read-only" access to aircraft data) via certified installation of an aircraft interface device (AID). By first completing the EFB hardware certifications, the TASAR approval process was greatly simplified, requiring only POI review and approval.

As increasingly more capable EFB applications such as TASAR are considered for the flight deck, these applications will transition from low-certification (e.g., Minor Effect) applications hosted on a standalone PED EFB to applications that interface with higher-criticality avionics systems (read-only, transmit-only, or both), while also connecting to external networks. Consequently, the FAA and industry must require sufficient protections to prevent interference by the EFB to avionics systems (e.g., Electro-Magnetic Interference (EMI) protection), provide cyber security, and require an AID to serve as a trusted interface between more critical avionics and airborne internet systems and the lower criticality PED EFB. A comprehensive review of policy requirements was conducted for authorization of a TASAR EFB system. Detailed results are reported in reference [28]. A summary is provided in the following sections.

7.1. Key FAA Regulatory Documents

Presented below are some of the cornerstone regulatory documents that provide guidance information and requirements that must be met in order to gain authorization for EFB-based flight deck applications. These documents were reviewed and assessed in detail in order to identify expected EFB standards adherence requirements for TASAR. These documents point to numerous secondary documents not listed here that contain additional authorization requirements an applicant must address as part of a certification project with FAA. The document versions listed were current at the time of the analysis.

- Title 14 of the Code of Federal Regulations (14 CFR) Parts 21, 23, 25, 27, 29, 43, 91F, 91K, 121, 125, and 135 [29]
- Flight Standards Information System 8900.1 Change 47, Vol. 4, Chapter 15 – EFB Operational Authorization Process [30]

Authorization Assessment

- This document provides the FAA approval perspective including POI checklists followed for approving EFBs and associated applications (e.g., TASAR).
- AC 120-76B, Guidelines for the Certification, Airworthiness, and Operational Approval of Electronic Flight Bag Computing Devices [31]
 - This document is intended for operators conducting flight operations under 14 CFR Parts 121, 125, 135, or 91 Subpart F (Part 91F) and Part 91K. It is a key guidance document for EFB use with applicability to TASAR.
- AC 20-173, Installation of Electronic Flight Bag Components [32]
- FAA Order 8110.4C, Type Certification [33]
- RTCA/DO-160G, “Environmental Conditions and Test Procedures for Airborne Equipment” [34]
 - Pertains to EMI and High Intensity Radio Frequency (HIRF) requirements for read-only and transmit data interfaces to avionics, respectively. TASAR requires read-only access to avionics and thus will need to meet EMI requirements (or delegate this requirement to an AID). In addition, wireless connectivity likely requires additional isolation testing (i.e., if TASAR is installed on a Transmit-PED) to ensure non-interference to avionics.
- AC 20-115, RTCA DO-178B, Software Considerations in Airborne Systems and Equipment Certification [35]

7.2. EFB Hardware

At the initiation of the TASAR project, the guiding FAA document for the certification, airworthiness, and operational approval of EFB computing devices was AC 120-76B, issued June 2012 [31] Two revisions followed (-76C in May 2014, -76D in October 2017) with AC 120-76D current at the completion of the TASAR project [22]. The two earlier revisions defined EFB hardware in terms of Classes (1, 2, or 3), but the 2017 revision dropped this distinction in favor of only two hardware distinctions: portable and installed equipment. Nevertheless, the Class distinction remains relevant for this discussion since the regulatory requirements analysis for this project was completed in 2015 and the Alaska Airlines EFB upgrade was completed in 2017 before the most recent revision was issued.

TASAR was envisioned to be implemented as a Class 2 EFB application. It requires a read-only interface to avionics systems, connection to aircraft power, and data link or internet connectivity for access to ground information sources. In most implementations, TASAR is expected to be implemented via a mounted PED, the most common type of Class 2 EFBs. The mounted PED requires interface to aircraft data through an AID. The hardware combination PED EFB and AID represent the entire Class 2 EFB system. The PED EFB must be capable of being easily removed from and attached to its cockpit mount by flight crew personnel. The EFB (with associated AID) must be installed in accordance with AC 20-173 [32]. As indicated in this AC, cockpit mount (versus a yoke mount) may reduce approval requirements. The portable Class 2 EFB components (e.g., PED) are not considered to be part of aircraft type design, i.e., not in the aircraft Type Certificate (TC) or Supplemental Type Certificate (STC). The installed components with aircraft connectivity (e.g., AID) require an STC. An STC is a recertification of the aircraft with the new component included.

The following high-level steps are needed for the installation and operational approval of a Class 2 EFB, such as for TASAR:

Authorization Assessment

1. Applicant must obtain approval via TC or STC for initial alterations related to mounting fixture installation and installation of power and/or data connectivity.
2. Manufacturer, provider, or installer must assure via testing that the Class 2 EFB provides interference-free operation. If a data transmitter is used to transmit data to the Class 2 EFB, it must be tested to RTCA DO-160G, section 21, paragraph M, ensuring conduction and radiation of emissions do not result in interference [34]
3. Applicant must obtain TC, STC, or DER approval for installation of antennas that provide data to the EFB, e.g., navigation, weather data. TASAR falls into this category, as it seeks to access information from network-enabled information services. However, since TASAR is of “No Effect” or “Minor Effect,” the data integrity required is expected to be relatively minor. TC, STC, or DER approval of installed antennas are generally not an issue if connecting the EFB to an aircraft’s existing In-Flight Connectivity (IFC, i.e., airborne internet) system, though connecting the AID to the IFC system will require an STC, a process which must also include addressing cybersecurity issues.
4. Applicant must obtain operational approval by Operational Specification (OpSpec) or by Management Specification (MSpec) and Letter of Authorization, A061, from the POI.

7.3. EFB Software

AC 120-76B provides detailed definitions and descriptions of EFB software related factors (e.g., Type A, B, C; hosted versus approved software). The revision AC 120-76D maintained the Type A and B application definitions (while updating the list of applications included in each) but dropped the Type C definition and the term “approved” software as no longer applicable to EFBs. Type A applications (listed in Appendix 1 of AC 120-76B and Appendix A of AC 120-76D) generally perform paper-replacement functions or present static data (e.g., manuals, logs, chart supplements). Type B applications (listed in Appendix 2 in AC 120-76B and Appendix B of AC 120-76D) generally produce dynamic data with algorithms that must be tested for accuracy and reliability by the applicant (e.g., weight and balance calculations, power settings, runway performance).

Though the definitions of Type A and B applications have migrated somewhat between document revisions, TASAR reflects the characteristics of Type B applications in both the earliest and latest revisions: (1) FEC of no more than “Minor,” and (2) includes variables in the information presented based on data-oriented software algorithms (in case of TASAR, using a variety of information sources for subsequent processing to determine route modification candidates). Whereas TASAR’s intended function was implied in the AC 120-76B list of Type B applications (i.e., en route performance calculations), it is explicitly listed in AC 120-76D (i.e., flight optimization planning software) possibly prompted by a NASA briefing on TASAR to FAA policy writers as part of this project. In this meeting, the policy writers explicitly removed any ambiguity of TASAR’s appropriate classification as Type B.

A question that remains open is the level of software certification required for TASAR. The FEC for TASAR was assessed to be within the range of “No Effect” to “Minor Effect.” AC 120-76B (applicable in the TASAR project’s formative years) and its replacement AC 120-76C both explicitly stated that Type B applications do not require compliance with RTCA/DO-178B (current version is -178C [35]), the primary document by which certification authorities approve all commercial software-based aerospace systems. However the current revision AC 120-76D is silent

Authorization Assessment

on RTCA/DO-178C conformance requirements, saying only that specific authorization for use by the FAA for each Type B EFB application must be documented in the OpSpecs or MSpecs.

As stated earlier, the TAP Display was updated during the project to include display of weather polygons and SUA polygons to aid pilots in interpreting the route modification advisories. This change could potentially solidify the FEC as “Minor Effect” based on the possibility of presenting hazardously misleading information (even predicated on there being a separate primary display of weather in the cockpit) [37]. According to RTCA/DO-178C, software with a Minor failure condition should meet the standards for Design Assurance Level D. It should be noted that Virgin America and Alaska Airlines both obtained operational approval with AC 120-76C in effect, which explicitly stated that RTCA/DO-178 compliance was not required for Type B applications. Future software implementations of TASAR may need to revisit whether DAL-D compliance is required based on AC 120-76D or any further revisions.

Given its heritage as “research code,” the NASA TAP software did not meet DAL-D compliance criteria during its use in the NASA TASAR project. To assess the potential for future DAL-D compliance, a software certification upgrade analysis was performed. The analysis concluded that while certifying the TAP source code directly in its present form would likely not be cost effective, the addition of several insulating layers of certified “validator” software could mitigate the hazards associated with most software failure modes [38][39].

Alternatively, a more detailed OSA may be in order to clarify the FEC (“Minor” vs. “No Effect”) given the display of airspace polygons and further evidence of whether or not TASAR increases pilot workload.

The following responsibilities were identified for the approvers and operators in the authorization process of the EFB applications such as TASAR:

FAA POI:

1. Verifies that:
 - a. application criteria and operator requirements are met
 - b. data updates follow maintenance manual and inspection program procedures
 - c. applicable job aids, including human factors evaluation are completed
 - d. training, checking, and currency programs are approved
 - e. operational evaluation report from operator is appropriately reviewed
 - f. OpSpec or MSpec A061 is issued upon completion of authorization process
2. Ensures that the level of information integrity is commensurate with the FEC

Operator:

1. Determines usage, architectural features, people, procedures, and equipment to eliminate, reduce, or control risks associated with an identified failure in a system
2. Performs 6-month operational validation per authority granted in OpSpec or MSpec A061
3. Uses both EFB device / system and conventional paper copies during evaluation (not applicable for TASAR)
4. Submits final evaluation report to the POI, as appropriate after evaluation

Authorization Assessment

5. Ensures operating system and hosted application software meet criteria for appropriate intended functions and do not provide false or hazardingly misleading information
6. Ensures software revision loading will not corrupt data integrity of original software

7.4. FAA Feedback on TASAR

The NASA TASAR team met with FAA certification (i.e., AIR), operational approval (i.e., AFS), and ADS-B (i.e., SBS) representatives to present the safety, certification, and operational approval analyses results and to gain FAA feedback early in the project (July 2013). The outcome of the meeting, at which NASA's briefing materials and results from analyses were reviewed, indicated TASAR should have minimal authorization requirements. The following is a summary of FAA feedback:

1. TASAR meets the definition of a Type-B application and does not need to be added explicitly to the list of Type B applications in AC 120-76B (though it later was added to AC 120-76D). Type-B applications running on non-certified hardware (e.g., Class 2 EFB) do not require DO-178B compliance.
2. TASAR is not considered a formal "ADS-B In application" but rather a performance/planning application that leverages ADS-B In data, if available.
3. No need was identified to establish a "TASAR standard."
4. TASAR should be viewed as a "Minor Effect" application because of potential pilot workload associated with TASAR due to misleading/bad data. From a loss of function standpoint, TASAR is viewed as "No Effect."
5. Existing policies already cover the proposed TASAR application.
6. If an end user already has a certified and approved EFB installation, then the operational approval process is for the user to go directly to the POI for review and approval of the EFB application.

The last two points of FAA feedback represented the major conclusion of this authorization assessment, that existing policies already cover the proposed application and that, from their standpoint, an applicant (e.g., an airline) should have no difficulty getting approval to implement TASAR. This finding supports NASA's objectives of developing a near-term, low-cost application for in-flight optimization of trajectories using ADS-B In traffic data to increase the likelihood of approval. The application enables airspace users to gain early benefits of onboard route optimization and ADS-B In at minimal investment risk, while also paving the way for the emergence of more advanced airborne trajectory management applications with even greater operational benefits.

8. Market Assessment

Market research through various forms of outreach to the commercial aviation community was conducted throughout the TASAR project and played an instrumental role in achieving its positive outcomes. Not only did it lead to two airlines signing partnership agreements to conduct operational evaluations, it generated a sustained interest in the aviation community, with numerous industry requests for information on licensing and multiple airlines expressing interest in adopting TASAR.

The objective of early market research was to determine the level of community interest in an airborne route optimization capability such as TASAR and their prospective readiness to adopt it. As project activities continued, community engagement was sustained in order to gauge the degree of alignment with evolving trends in industry technologies, including not only TASAR's foundational infrastructure (e.g., "connected" EFB, ADS-B In) but also future opportunities for integrating TASAR with emerging technologies (e.g., onboard multi-scan weather radar, data communications). Outreach also established important relationships in identifying a potential partner airline (or two) to conduct an operational evaluation of TASAR and in communicating the commercialization opportunities to potential TASAR vendors in the aviation industry.

One of the first TASAR market research activities was a community survey issued to commercial aircraft operators. Complementing this research effort were direct meetings and presentations to airlines, industry vendors, government organizations, and relevant aviation community groups at various established venues. Rounding out the outreach strategy were the publication and presentation of technical papers at mainstream aviation conferences as well as a variety of media activities. The following sections summarize these various TASAR project outreach strategies, activities, and outcomes.

8.1. Aircraft Operator Community Survey

The first significant outreach activity was an assessment of the community need for the route optimization capabilities of TASAR. The target community was the airspace users (i.e., aircraft operators) based on the assumption that if the demand exists (or will exist), the suppliers will come. This market research activity would assess the current state and planned investments in infrastructure needed to support TASAR technology, and it would gauge the prospective value TASAR could bring to existing tools and procedures already employed by aircraft operators for route optimization. Results of the community survey are documented in reference [28].

Three operators were surveyed: a global Network Carrier, a domestic Low-Cost Airline, and a Fractional Operator of business aircraft. Given the small sample size of survey respondents, the responses could not be used for generalizable conclusions for all aircraft operators. However, the multiple responses received from each stakeholder community within these organizations who are involved in flight planning and execution (i.e., responses from multiple pilots, dispatchers, and flight operations managers) did allow reasonable observations to be made regarding market readiness for TASAR.

As can be illustrated in four ways, the three operators responding to the survey represented an appropriate spectrum of the potential TASAR user community and the diversity of operations among aircraft operators in the U.S.

Market Assessment

1. **Fleet Makeup.** The two airlines surveyed are air transport operators and operate fleets strictly comprised of Boeing and Airbus transport category aircraft. The Fractional Operator on the other hand operates a wide range of business aircraft types as part of their aircraft fleet. Having more aircraft types within an airline is a cost disadvantage, particularly if multiple “first of type” certifications are required to integrate the required equipment for TASAR.
2. **Flight Duration.** Two-thirds of Fractional Operator flights were reported in the survey as short haul (<2 hours), whereas two-thirds of the two airlines’ operations were reported as medium to long haul (>2 hours), with 40 percent being long haul (>4 hours). The preliminary benefits analysis in Chapter 5 indicated that TASAR will likely provide the most benefits for medium to long haul flights [17]. While all three operators can benefit from TASAR, the longer haul flights of the Network Carrier and the Low-Cost Airline should be expected to gain additional benefits.
3. **Airport Size.** Based on the Network Carrier and Low-Cost Airline route structures, a greater percentage of hub-to-hub flights would be expected. Since the Fractional Operator has a majority of its flights operating from/to non-hub airports, this removes a significant set of constraint factors related to ATC ground stops/holds, metering, etc. While potentially removing some opportunities for significant benefits (e.g., efficiently recovering from expiring ATC traffic management initiatives), it also potentially allows for more flexibility for in-flight route optimization and thus increased opportunities to use TASAR to accumulate smaller benefits.
4. **Scale of Operations.** A clear difference exists in the number of pilots, the number of airborne flights, and the number of dispatchers utilized by the three operators, ranging from very large numbers for the Network Carrier to relatively small numbers for the Low Cost Airline and the Fractional Operator. These smaller operators have fewer available ground resources to optimize flights after departure, making a stronger case for flight optimization technology in the cockpit.

Some general observations from the community survey are presented next. As survey results were received during 2013, future plans and actual levels of equipment of the surveyed operators may have later changed based on regulatory and market forces. The observations below represent operator equipment and plans as of 2013 and reflect differences between operators and their respective markets.

1. Given a favorable cost-benefit business case for TASAR, all three operators could quickly equip for full TASAR functionality with the following three pieces of infrastructure.
 - o Class 2 EFB: The operators have diverse plans for EFB use spanning all Classes of EFB hardware and operating systems (mix of Windows, LINUX, and iOS). All users should be able to utilize their EFBs to host TASAR, although Class 1 EFBs will need to interface to an AID. As of 2013, the operators were generally well on their way to having this capability that would support early adoption of TASAR.
 - o Internet connectivity: As of 2013, the Fractional Operator had, and the Low-Cost Carrier was shortly to have, excellent internet access for their aircraft. The Network Carrier appeared to be the most challenged in network connectivity for future TASAR use, but could potentially leverage available cabin internet services they provide for

Market Assessment

passengers to support flight deck applications such as TASAR. Additional certification would be required to address cybersecurity issues associated with connecting the cabin and cockpit domains.

- ADS-B In: Anticipated ADS-B Out equipage levels for the three operators suggested a relatively slow deployment, resulting in a significant number of aircraft being unequipped for several years. In other words, a mixed-equipage environment was expected all the way to the 2020 mandate. Only one of the three operators had plans for ADS-B In equipage. TASAR may need to be bundled with other ADS-B In applications to form a sufficient business case for upgrading ADS-B Out to ADS-B In.
2. Flight operations throughout the year typically offer ample opportunities for re-optimization of airborne flights, given the frequency of flight plan disruptions reported by pilots and dispatchers due to en route weather and ATC constraints on operational efficiency.
 3. Pilots have considerable latitude for making route modification requests, particularly for altitude and speed changes, guided by the company Operations Control Manual. Requests for lateral path changes are more likely to require dispatch approval, though dispatch approval is not frequently sought in practice. Sufficient pilot empowerment is in place at the surveyed operators to allow use of TASAR capabilities to seek improvements to the current flight plan.
 4. From a dispatch perspective pertaining to time spent on flight optimization, there is a tradeoff on time spent versus savings achieved. Given the current state of tools used in re-planning, the time it takes to use them to identify flight optimization opportunities and consider alternatives, and the already high workload dispatchers have in planning upcoming flights, little effort is typically expended by dispatchers on optimizing flights after departure.
 5. TASAR, with pertinent, accurate, and timely information on weather information and ATC constraints en route and at the destination, has the potential to provide significant flight optimization capabilities and increase operational efficiency.

In summary, based on airspace user community input from 2013, TASAR equipage is readily achievable (with the possible exception of ADS-B In), frequent opportunities for TASAR utilization and benefit are expected, and TASAR procedures are consistent with the existing role of the pilot and availability of the dispatcher, thereby filling a key gap in maintaining flight operations efficiency.

8.2. Airline Engagement

Initial outreach to airlines focused on introducing the TASAR concept and soliciting input for the community survey described in the preceding section. As major airlines are not necessarily the most likely candidates to be “early adopters” of unproven aircraft technology, the outreach effort was expanded to include not just the major Network Carrier (traditionally the focus of NASA AOSP research) but also alternative stakeholders such as the Low Cost Airline and the Fractional Operator. Dedicated briefings were held with each of these operators with the intent (beyond soliciting input for the community survey) of laying the groundwork for potential industry-NASA partnerships and collaborative operational evaluations of TASAR. Though all three responded favorably to TASAR, the most affirmative response for a potential operational evaluation partnership came from the Fractional Operator. Essentially running a non-scheduled airline, fractional operators maintain diverse fleets of business jets and cater to clientele who expect cutting-edge technology. In this respect, such operators could be fertile ground for TASAR’s

Market Assessment

technology insertion strategy. Ultimately, the collaboration with the Fractional Operator did not materialize in part due to departure of key personnel from the company but also a mismatch with AOSP's traditional focus on the scheduled airlines.

Over the life of the TASAR project, dedicated briefings were given to seven U.S. airlines: Alaska Airlines, American Airlines, Delta Airlines, JetBlue Airways, Southwest Airlines, United Airlines, and Virgin America. By the latter half of the project, Network Carriers were traveling to NASA to meet explicitly on TASAR and extending an invitation to their headquarters to brief a wide contingent of personnel from the various departments involved in investment decisions or operational use.

The ability to give a demonstration of the actual TAP software connected to a laptop flight simulator was instrumental to the effectiveness of these outreach meetings. The "mobile demo" brought a tangible element to the briefing and discussions, and it provided a hands-on experience to participants, which in turn generated heightened interest in the technology.

The presentations on findings from the preliminary analyses on TASAR benefits, safety, and FAA authorization were also instrumental to the strong reception repeatedly received in these meetings. Having these results on hand, or knowing they were in progress, helped build the necessary credibility in the technology's viability from the perspective of the airlines. When questions were raised in briefings, NASA generally already had relevant answers in published reports.

By far the most effective approach for securing airline interest and engagement in the TASAR project was the strategy of inviting technical (tech) pilots from a variety of airlines to participate in the NASA flight trials (described in Chapter 11). Tech pilots perform many additional functions beyond flying scheduled operations, one of which is to evaluate new aircraft technologies for potential integration into the fleet. Inviting tech pilots to serve as technology evaluators in the flight trials served two purposes. It enabled the pilots to give NASA feedback on the features and operational acceptability of the TAP software, and it provided them the opportunity to assess the technology first hand for their airline and consider the possibility of conducting a collaborative operational evaluation with TAP installed on their aircraft. Most of the participating pilots were either the airline's Director of Fleet Technology (or similar position) authorized to make technology decisions, or senior instructor pilots (captains) with enough clout to make technology recommendations to the director. Upon the completion of the first flight trial (FT-1) in 2013, four airlines expressed interest in pursuing the TASAR technology for their fleets, two of which signed Space Act Agreements (SAAs) with NASA to conduct operational evaluations on their aircraft in revenue service.

Building on the contacts made with the airlines in FT-1, the strategy was employed again for the second human-in-the-loop simulation (HITL-2) and second Flight Trial (FT-2). To build interest within the tech pilot communities of the partner airlines, 10 of the 12 simulation sessions in HITL-2 were reserved for these two airlines who supplied pilots of their choosing. In FT-2, six evaluation seats were reserved for these airlines, and four seats were provided to four other airlines, three of which were new to TASAR.

8.3. Industry Engagement

Although the aircraft operators (e.g., airlines) are the ultimate intended users of TASAR, the path to widespread commercial use is through the industry of aviation systems suppliers. It would

Market Assessment

ultimately be necessary for one or more of these companies to get a commercial license from NASA for the technology and leverage it as needed to produce a commercial TASAR product that they then supply to the aircraft operator community. It would also most likely be incumbent upon industry to perform the engineering work to adapt the technology to each aircraft type and operator configuration. TAP or derivatives developed by industry require adaptation because of the variations in avionics systems, outputs, and wiring between fleets and to account for differences in aircraft performance. Also, the various configurations of EFB hardware and connectivity will require customized solutions.

The industry companies that showed the earliest serious commercial interest in TASAR were providers of EFB-related hardware and providers of internal and external connectivity solutions. An attractive property of a software application like TASAR to these companies was its potential to help build the business case for their emergent product lines. Over time, more companies began to see TASAR as more than a “teaser” but actually a complement to their established product line and potentially even a principal product itself. It is too early to tell how these visions will unfold in the long term. Based on inquiries for evaluation licenses, the types of companies exploring commercialization of TASAR increased in diversity during the TASAR project. Table 7 shows the range of industries that showed commercial interest in TASAR and their associated diversity of motivations as gleaned from company discussions.

Table 7. Diverse industries with diverse motivations for TASAR commercialization.

Industries	Commercial Interest
Navigation avionics	Offer TASAR in conjunction with flight management systems
Airborne internet	Offer TASAR as business case for the “connected cockpit” revolution
EFB hardware & connectivity	Offer TASAR to incentivize avionics-interfacing hardware/software products
Surveillance avionics	Offer TASAR to incentivize operators to equip with ADS-B IN
Flight efficiency services	Offer TASAR to expand services to include rerouting with traffic avoidance
Weather data services	Offer TASAR to integrate with their weather data products
Airlines	Deploy TASAR across their fleets for fuel efficiency benefit
Business aviation	Deploy TASAR for point-to-point route optimization and range extension
Original Equipment Manufacturer	Use TASAR/TAP as a foundation for UAM autonomous flight planning
Small Business innovators	Develop TASAR to enhance their in-house innovative products and services

Outreach to industry was initially performed through meetings requested of known points of contact and subsequently through invitations received to present TASAR in various venues. Presentations were initially given alongside talks on other new technologies, then more frequently in requested, dedicated TASAR briefings. Key opportunities also emerged through NASA’s new partner airlines, as they pointed NASA to existing or potential vendors that could supply the connected EFB platform for the operational evaluations. In each of these outreach activities, NASA’s mobile demonstration system greatly facilitated the communication of the concept and technology, just as it did in the airline briefings. And similarly, having published analysis results on hand regarding benefits, safety, and FAA authorization built confidence in the industry that TASAR was indeed a viable commercial product worthy of attention.

Market Assessment

8.4. Government Organization Engagement

TASAR outreach also extended to relevant Government organizations. The first such activity was a July 2013 briefing to FAA officials in AIR, AFS, and SBS. These offices write FAA policy for certification of EFB hardware, operational approval of EFB software applications, and ADS-B technologies and procedures. The meeting purpose was to present the proposed technology with analyses of safety and approval requirements for critique and feedback. In doing so, it helped achieve a level of familiarity and support at the FAA that later paid dividends as other FAA officials contacted them with questions about TASAR. The FAA POIs for the two partner airlines, Virgin America and Alaska Airlines, sent inquiries to these offices after having received the applications submitted by the airlines requesting TAP be approved as EFB software. Pre-briefing these policy officials facilitated their dialogue with the POIs and the subsequent issuance of formal operational approval for both airlines.

Another opportunity to brief FAA personnel was triggered by the second NASA flight trial in 2015. FT-2 included a research objective of assessing ATC approvability factors associated with route modification requests through TASAR. (FT-2 is described in Chapter 11.2.) Achieving this objective involved stationing NASA team researchers at ATC facilities to observe the flight-test aircraft's TASAR requests from the perspective of the air traffic controller, and then interviewing the air traffic controllers for their perspective on factors leading to request approval or denial. Outreach trips to the Atlanta and Jacksonville Air Route Traffic Control Centers in advance of FT-2 provided the first opportunity to present TASAR to the ATC community, one that might have a wholly different perspective on the proposed technology than the user community. The current ATC system is largely centered on facilitating pre-approved flight plans that are well aligned with the airspace system structure (e.g., jet routes, sector geometries supporting dominant traffic flows). It was uncertain what the reception would be to an aircraft technology that continually prompts pilots to request route modifications that may deviate from that structure. In fact, the reception was quite favorable. They appreciated the technology design to accommodate ATC constraints and increase approvability, thus facilitating pilot/controller interactions and mitigating the impact on controller workload. More to the point, they appreciated being included at this early stage of the technology's development and testing and having their input considered in its design. This outreach also reached beyond the initial meetings with facility managers and extended to the actual air traffic control workforce through on-site observations and interviews.

The FT-2 activity also attracted the attention of the National Air Traffic Controllers Association (NATCA), the air traffic controller union. Their bargaining agreement gives them the right to negotiate with the FAA over their role in new technologies like TASAR. Prior to FT-2, NATCA approval was received to enable researchers to interview air traffic controllers. After FT-2 was complete and having received a copy of the FT-2 analysis report on the ATC observations, NATCA requested a full TASAR briefing. Through the briefing, they learned that the role of controller does not change with TASAR, and no controller training is required. Discussions centered on their concerns of the increased frequency of user requests and potential challenges integrating with other emerging technologies like time-based flow management. Though not strictly an outreach activity, these interactions with NATCA may eventually pay dividends when the opportunity arises to integrate TASAR and derivative technologies with emerging NextGen technologies such as Data Communications (Data Comm) that would alleviate some NATCA concerns.

Market Assessment

Government outreach on TASAR also occurred through regular NASA-FAA quarterly meetings, technical interchange meetings, research transition teams, and meetings with key FAA technology leaders. Two such interactions centered on the likely synergy of TASAR with the FAA's programs on Data Comm and SWIM. These leadership interactions generated substantial interest due to TASAR's roadmap alignment with these programs. Data Comm will soon replace much of the voice communications between pilots and air traffic controllers, but only for those aircraft operators that voluntarily equip for Data Comm. It was clear to FAA Data Comm officials how TASAR could inspire such equipage because the integration could enable more sophisticated route modification requests while reducing pilot and controller workload. Similarly, SWIM leaders saw an opportunity in TASAR to showcase SWIM as a common data source for ground-based and airborne trajectory management technologies. Again, with SWIM being a voluntary system, TASAR could inspire the aircraft operator community to gain "Aircraft Access to SWIM" (the title of an FAA project with this goal). The capstone of outreach activities with the FAA was a TASAR endorsement by the venerable FAA Chief Scientist for NextGen, Steve Bradford, who invited NASA to Brussels to present TASAR to the International Civil Aviation Organization (ICAO) Air Traffic Management Requirements and Performance Panel at their June 2017 Technical Interchange Meeting, "Evolution Towards Global Trajectory-Based Operations (TBO)."

TASAR's Government outreach also extended to the Aviation Weather Center (AWC) of the National Oceanic and Atmospheric Administration (NOAA). The director of the AWC was invited to participate as an evaluation pilot in FT-1. This facilitated subsequent TASAR team access to NOAA expertise in atmospheric modeling supporting the aviation community (and many others). TAP consumes atmospheric data, including winds, temperature, and convective weather, with turbulence data intended for future development. The original plan was to exclusively use public data sources to facilitate technology transfer to the broadest cross-section of aircraft operators. Though the plan was partially modified due to Alaska Airlines policy requiring use of a private convective weather data source, TAP retained the use of NOAA wind and temperature data throughout the project.

8.5. Broader Aviation Community Engagement

Complementing the targeted outreach described above, which was generally dedicated interactions with specific individuals or companies, several opportunities emerged to talk to wider communities. Some opportunities were internally generated by NASA, such as "Industry Day" events where a cross-section of aircraft operators, aviation system suppliers, and related organizations attend to engage with NASA on current and future research. In fact, the first ever TASAR briefing occurred at a 2011 Industry Day sponsored by the NASA Airspace Systems Program. As this was before the TASAR project officially started, the briefing included a low-fidelity mockup demonstration of the proposed technology. Another early opportunity emerged to connect with a representative of the National Business Aviation Association (NBAA). Later in the project, NASA was invited to brief TASAR to the "Friends and Partners of Aviation Weather" at an NBAA event.

The most impactful venue for TASAR outreach in terms of dissemination to the broadest and most relevant community was the EFB Users Forum, the world's largest industry conference on EFB technology. Held semiannually in locations alternating between U.S. and overseas locations, the EFB Users Forum is sponsored by the Airlines Electronic Engineering Committee, an

Market Assessment

international standards organization that represents technical positions of the air transport industry. The EFB Users Forum attracts several hundred attendees from airlines, system integrators, hardware and software suppliers, and regulators to discuss operational and technical trends of interest to the EFB user community. One company interested in TASAR commercialization invited NASA to set up a TASAR demonstration at their booth for the June 2015 forum in Denver. The opportunity was leveraged to secure an invited TASAR briefing to the full audience of 400 attendees. Jointly presented by NASA and Alaska Airlines, the presentation was very successful in generating a significant degree of interest in TASAR as indicated from a variety of domestic and international airlines, avionics vendors, and data connectivity suppliers through side meetings and requests for more information. NASA was invited twice more, presenting at the Vienna Forum in June 2017 and the Chicago Forum in June 2019.

TASAR was taking hold in the consciousness of the aviation community as was evident by invitations for NASA to present TASAR to various industry working groups such as the Communications, Navigation, Surveillance Task Force (August 2015); the Boeing Data Comm Working Group (November 2015); the RTCA NextGen Advisory Committee Performance Based Navigation Task Group on Time, Speed, and Spacing (August 2016); the Base of Aircraft Data Users Conference (May 2017), the aforementioned Friends and Partners of Aviation Weather at the NBAA conference (October 2017); and the RTCA Special Committee 206 Aeronautical Information and Meteorological Data Link Services plenary session (March 2018). The number and diversity of these invitations indicated industry's positive view on TASAR's relevance to a broad spectrum of aviation activities.

8.6. Research Community Engagement

TASAR project accomplishments were shared with the research community primarily through conference publications and presentation. These methods for dissemination were to ensure that TASAR research findings were readily accessible to both the research and industry communities, while subjecting TASAR to welcomed scrutiny from peers conducting related research on other advanced trajectory management concepts and technologies. Every project year from 2012 to 2019 had at least one TASAR conference publication, often several. The primary venue for publication was the annual *American Institute of Aeronautics and Astronautics (AIAA) Aviation Technology, Integration, and Operations Conference* later consolidated under the *AIAA AVIATION Forum* (seven publications). Other venues included the *AIAA Guidance, Navigation, and Control Conference* (two publications), the *Digital Systems Avionics Conference* (two publications), the *U.S.A./Europe Air Traffic Management Research and Development Seminar* (one publication), and the *Human Factors and Ergonomics Society Annual Meeting* (one publication). The NASA Scientific and Technical Information Program served as an additional venue for publishing the more lengthy reports and making them publically accessible online through the searchable NASA Technical Report Server.

8.7. Public Engagement

Supplementing the technical outreach activities were efforts to communicate the innovations of the TASAR project to broader aviation and non-aviation audiences through various public media. For instance, several TASAR articles appeared during the project lifespan in *Aviation Week and Space Technology* and *Avionics Magazine*, both of which are widely read throughout the aviation industry. A NASA press release announcing the partnerships with Alaska Airlines and Virgin

Market Assessment

America spawned dozens of articles on TASAR by news outlets around the world. TASAR also received prominent mention in articles on the two airlines and their ongoing technology programs, as well as online articles and print publications of the industry companies supporting the NASA/airline partnerships. An example is a 2016 book written and published by Gogo (supplier of in-flight connectivity, i.e., airborne internet) on the rise and revolutionary impact of “connected aviation” [12]. The book highlights TASAR not only as a current-day example of leveraging connectivity to enhance route optimization but also how TASAR leads to autonomy in future aircraft operations.

The NASA Technology Transfer Program also sponsored several outreach products to promote TASAR commercialization, including a one-hour online technical webinar, a promotional video on the technology, and an online fact sheet. TASAR was also featured on the radio series and podcast *Innovation Now*, which reaches a wide public audience.

9. Technology Prototype

The centerpiece of TASAR is cockpit-based, connectivity-enabled, software technology that searches for and advises the pilot on route optimization opportunities, enabling the pilot to make “strategic requests” to ATC that produce operational benefits. TAP is NASA’s prototype of the envisioned TASAR software technology. Though the terms TAP and TASAR are sometimes used interchangeably, the intended distinction is that TAP is the software application, and TASAR is the concept of pilots using software applications (e.g., TAP or its derivatives) to proactively optimize their route as a first step on the roadmap of airborne trajectory management towards operational autonomy [7]. Based on the starting level of functionality built into the TAP prototype for the NASA TASAR project, the scope of route optimization as described in this report includes the aircraft’s lateral path and cruise altitude, with certain constraints applied to accommodate practical limitations of making voice requests to ATC. The concept of TASAR, however, extends beyond these limits to encompass optimizing the aircraft’s 4D trajectory (i.e., speed profile changes in addition to complex lateral path and altitude profile changes) unconstrained by the voice request limitations. In these respects, TAP will be able to support the full concept of TASAR with additional software development, either by NASA for future Research and Development projects or by industry through further commercial development of TAP or derivative products.

NASA’s prototype TAP software technology is described in references [40] (original 2013 description) and [41] (updated 2016 description). The sections below discuss its heritage, give a functional overview, and highlight unique features designed to increase its commercial viability and appeal. Table 8 presents the TAP version history with approximate release dates and the primary use of each version.

Table 8. TAP software version history.

TAP Version	Release Date	Primary use
1	Nov 2012	Initial prototype
2	July 2013	HITL-1 simulation experiment
3	Oct 2013	FT-1 flight trial
14-1	Sept 2014	HITL-2 simulation experiment
15-2	June 2015	FT-2 flight trial
15-3	Sept 2016	Alaska-compatible prototype
15-4	Feb 2018	Alaska operational evaluation
15-3.11	Dec 2018	License release (15-4 w/ BADA removed)
19-6	Feb 2019	Project compete prototype

9.1. Heritage from Autonomy Research Technology (AOP)

TAP is a derivative of the AOP software, NASA’s research prototype of an advanced flight-deck automation system to support self-separation of aircraft [13]. As discussed in Chapter 2, the motivation for TASAR is rooted in the vision of aircraft operational autonomy in which aircraft manage their own trajectories throughout most of their flight without the assistance of ATC. In support of extensive experimental research into aircraft operational autonomy (as described by

Technology Prototype

AFR, a NASA concept for airborne operational autonomy) and its central function of self-separation (i.e., an aircraft independently detecting, resolving, and preventing conflicts with other aircraft), NASA developed AOP to investigate functional requirements for the AFR-enabling onboard automation technology that would enable AFR [6][9]. AOP was developed and used in multiple batch and HITL simulation experiments in the period 2001–2012, culminating in a pair of HITL simulations with airline pilots and air traffic controllers conducting “mixed operations” in which AFR (autonomous) and IFR (ATC-managed) aircraft coexist without segregation in high-altitude en route airspace [11].

The intent of building AOP was to enable investigations of technical and operational feasibility of the AFR concept. AOP’s design philosophy was to ensure that any *negative* findings of AFR feasibility were not the inadvertent byproduct of some inadequacy of the technology used in the assessment. The design goal therefore was to include in AOP’s architecture and suite of functions a sufficient degree of fidelity and sophistication to maximize the likelihood of AFR operational feasibility when tested in conditions simulating complexities of real-world operations. As it turned out, this early design approach was instrumental in enabling AOP to later serve as the foundation for a derivative tool (TAP) that could be taken out of the lab, installed in multiple aircraft including an airliner, and be used in actual airline operations.

Two sophisticated functions that set AOP apart were leveraged in TAP. These were its conflict detection algorithm (AOP CD) [42] and its “pattern-based genetic algorithm” for airborne conflict resolution (AOP PBGA) [43]. AOP CD was uniquely sophisticated in several respects. First, it was designed to incorporate “trajectory intent” information if available, but also to work in the absence of intent information. Intent information includes planned turns, altitude changes, and speed changes, and it can apply to the ownship or the traffic aircraft. More intent information yields a more accurate trajectory prediction and therefore more accurate detection of conflicts between trajectories. Airborne availability of intent information is limited today to ownship information but may increase in the future for traffic information. The ability to handle varying degrees of availability of intent information is critical to operational feasibility of a mixed operations concept like AFR, since availability will likely vary between aircraft.

Second, AOP CD accommodates trajectory prediction uncertainties due to factors such as navigation modeling errors and atmospheric effects. These effects accrue from differences between the trajectory prediction model’s assumptions and the actual complex characteristics of the aircraft and the atmosphere. AOP mitigates these effects by applying “4D uncertainty bounds” to the along-path, cross-track, and altitude dimensions of the predicted trajectory for the ownship and every traffic aircraft. Enveloping the baseline trajectory prediction, these uncertainty bounds can be tailored to the particular prediction errors associated with each dimension and further customized by factors such as auto-flight system characteristics. The result is fewer “missed alerts” (i.e., a false-positive conflict), an important safety element in autonomous operations.

AOP PBGA provided a sophisticated method to search for a “strategic resolution” to a detected conflict. In the parlance of AOP, a strategic conflict resolution is essentially a modified flight plan consisting of the addition or removal of intermediate waypoints from the FMS “active route” that resolves the detected conflict and avoids creating any other conflicts within defined time horizons. (In contrast to a strategic resolution, a “tactical” resolution would be a single maneuver, e.g., a heading change, to resolve the detected conflict with the return plan to be determined later.) The sophisticated aspect of AOP PBGA is its ability to search a large quantity of candidate route changes, account for a multitude of diverse “fitness” factors, and through successive generations

Technology Prototype

of mating and mutation, home in on the optimal solution, where “optimal” is defined by a fitness function. For instance, as AOP PBGA evaluates candidate route changes (starting with random sampling), it applies fitness penalties to those in conflict with traffic, weather, and SUA while rewarding those that are more “on time” and have greater cost savings (measured in time or fuel). Characteristics of route-change “winners” are perpetuated as-is or through mating to future generations, while “losers” are dropped. (A more detailed description of the algorithm is presented in reference [43].) The outcome of AOP PBGA is a strategic route change that is both conflict free (within defined parameters) and optimized for cost and schedule adherence. Batch simulation studies, with randomized-geometry encounters up to five times today’s traffic density, have shown AOP CD and AOP PBGA to be highly effective self-separation algorithms [10]. Similar studies have stress-tested the algorithms in various ways, and refinements have produced software code that is both robust and computationally efficient. As will be discussed, TAP leveraged these algorithms and therefore benefited from AOP’s years of development, testing, and debugging.

In addition to TAP leveraging the heritage of AOP’s algorithms, it also inherited a software architecture that was designed to work in a realistic avionics environment. As mentioned earlier, AOP’s design philosophy was to incorporate fidelity high enough that AFR infeasibility could not be attributed to simplifying assumptions of the technology prototypes used in the research assessments. A principal example was the specification used for avionics input data into AOP. The NASA desktop flight simulator used for AFR research was purposefully designed with a simulated ARINC 429 avionics data bus, the standard used on most higher-end transport category aircraft that defines the data protocol for the exchange of avionics data within the aircraft. Furthermore, the simulator’s FMS used the ARINC 702A characteristic in the specification of route data on the avionics data bus. Adherence to these industry standards brought AOP in close alignment with how a commercial automation system would receive data in an actual aircraft environment, with all of its limitations in content, data precision, and transfer rate. AOP’s input/output subsystem was designed to handle these inputs and work within their constraints, thus adding another check on AFR technical feasibility. However it also put AOP in a position to provide TAP an excellent foundational architecture adaptable to a hardware avionics environment. This factor was instrumental in the rapid development of TAP and its readiness for flight testing early in the TASAR project.

9.2. Functional description

TAP’s function is to continuously probe for candidate route modifications (including lateral path and cruise altitude changes) that optimize the flight across the entire route while avoiding the creation of conflicts with traffic, weather, and SUA. TAP implements the strategic trajectory-management functionality prototyped in AOP in a non-safety-critical application appropriate for current-day use.

9.2.1. Inputs

Through onboard connectivity to avionics data, and internet connectivity to external data regarding the operational environment, TAP maintains a current model representation of the flight and the relevant airspace. Figure 7 shows that the model’s inputs include the state of the aircraft (e.g., position, altitude, speed, track, weight), the aircraft’s active route to the destination, an atmospheric model including winds and temperature, current and predicted locations of convective weather, the published activation schedules of SUA, and the state vectors of nearby broadcasting

Technology Prototype

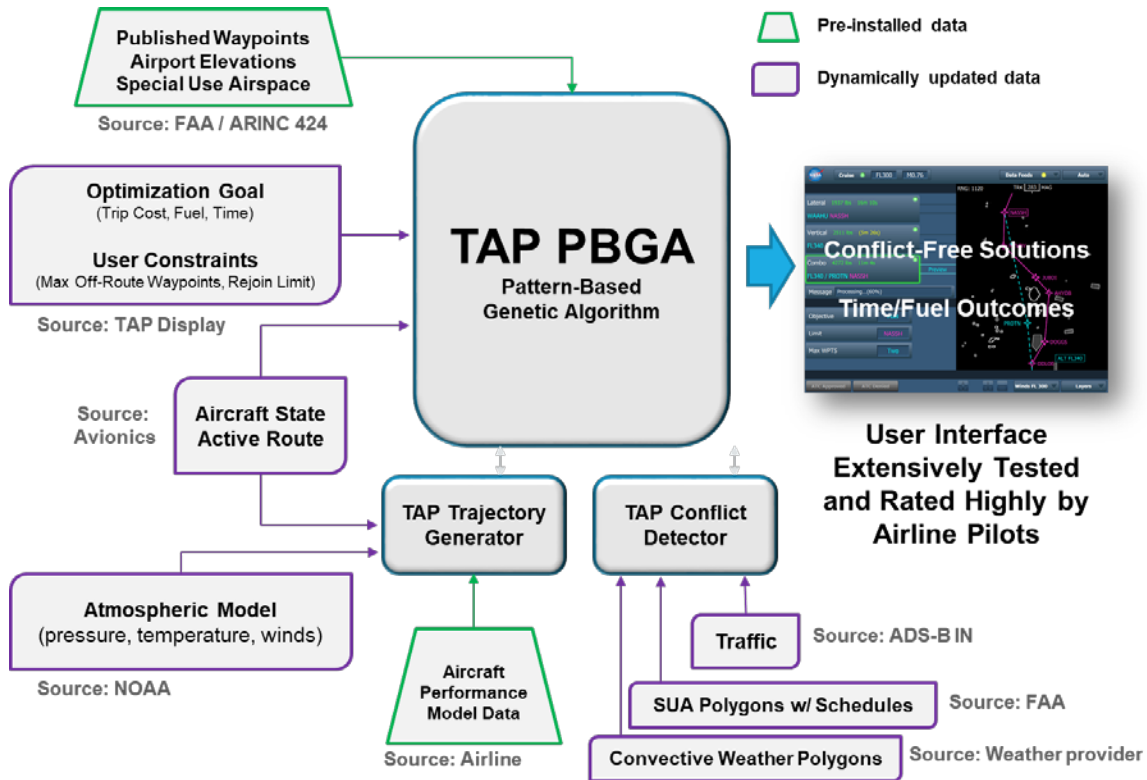

Figure 7. Variety of inputs and algorithms used by TAP for conflict-free route optimization.

traffic aircraft. TAP's three primary algorithms, TAP Trajectory Generator (TAP TG), TAP Conflict Detector (TAP CD), and TAP Pattern-Based Genetic Algorithm (TAP PBGA), ingest these dynamically updated data, along with user entries and pre-installed (non-dynamic) data, to support the pilot in route optimization. TAP CD and TAP PBGA were inherited directly from AOP (with modifications for TASAR, for example new maneuver templates in TAP PBGA). TAP TG was newly developed for the TASAR project, employing a novel behavioral modeling methodology to make it more adaptable to a wide variety of aircraft types [44].

9.2.2. Optimization

As prototyped in this project, TAP's degrees of freedom to optimize the route include the aircraft's lateral path and cruise altitude. Periodically (typically once per minute), TAP PBGA conducts a search for route modifications to improve a specified flight-optimization parameter. Selected by the pilot, the optimization parameter most typically used is the operational cost of the flight (combining fuel burn and flight time according to a given Cost Index). Thus TAP seeks to minimize the operating cost through proposed changes in the aircraft's lateral path and cruise altitude. Other options for optimization include pure flight time optimization and pure fuel burn optimization. For every candidate route modification generated by TAP PBGA, TAP TG computes flight time and fuel burn to the destination, as it also does for the current route. The route modifications with the greatest savings are favored by TAP PBGA as it proceeds through multiple generations of candidate route modifications.

Technology Prototype

9.2.3. Constraints

Constraints are applied in the TAP PBGA search process to enhance acceptability of the proposed route modifications to the pilot and air traffic controller, both of whom must concur with the proposed change for it to be executed and produce the desired benefit. For example, to enhance pilot acceptability, TAP avoids proposing route modifications that intersect with current and forecast convective weather, as such routes would likely be rejected by the pilot who is responsible for avoiding hazardous weather. Weather design considerations for TAP are described in reference [45]. To enhance ATC acceptability, TAP avoids proposing route modifications that would create a traffic conflict or intersect with an active SUA, both of which would result in ATC denying the request. Conflicts with traffic, SUAs, and weather along the candidate route modifications are detected by TAP CD and are incorporated in TAP PBGA by adding significant fitness penalties, essentially removing them from the “gene pool” and discouraging the generation of similar route modification candidates.

TAP facilitates voice communication of requests by constraining the proposed lateral path to published (fixed location and name) waypoints, while also limiting the maximum number of waypoints added to two but not limiting the waypoints bypassed, thus keeping the voice requests and responses short. In addition, the pilot is able to specify a farthest waypoint “limit” for the route modification to rejoin the active route, allowing the pilot to use their operational experience with ATC approvals to restrict the longitudinal extent of the request and increase the likelihood of approval. The pilot can also set an upper limit to altitude searches to ensure compatibility with FMS altitude limits.

9.2.4. Route Modification Solutions

TAP produces three independently generated route modification proposals, or *solutions*: (1) a lateral solution, which modifies the path but not the altitude; (2) a vertical solution, which modifies the cruise altitude but not the lateral path; and (3) a combination (“combo”) solution, which modifies both. Each solution type presented to the pilot is the most optimal, conflict-free solution identified within its degrees of freedom (lateral, vertical, or combo). This multi-dimensional optimization design provides pilots with alternatives, rather than just a single recommendation, which is intended to increase TAP’s usefulness when other factors unknown to TAP may dictate a pilot’s choice of maneuver.

9.2.5. User Interface

The TAP user interface was developed through an iterative human-factors design process and subsequently enhanced over the course of the TASAR project. Human factors principles were applied to enhance usability and situation awareness (SA) without significantly affecting pilot workload. Figure 8 shows the primary TAP user interface for TAP’s automatic mode (“Auto Mode”). In this mode, TAP displays the three solutions on selectable buttons (Lateral, Vertical, and Combo), the predicted outcomes in fuel burn and flight time (savings are shown in green), and a graphic preview of any of the route modifications relative to the active route (TAP solution is shown in cyan).

In addition to Auto Mode in which TAP periodically generates and displays route modification advisories for pilot consideration, TAP also has a “Manual Mode” in which the pilot may enter a route modification from scratch or modify a selected Auto Mode solution. Figure 9 shows the Manual Mode user interface, depicting a pilot-entered route modification that conflicts with traffic.

Technology Prototype

The pilot could use this information to either wait for the traffic indication to clear before making the ATC request or modify the request to be clear of traffic.

The TAP user interface design was issued a U.S. patent in 2018 [46].

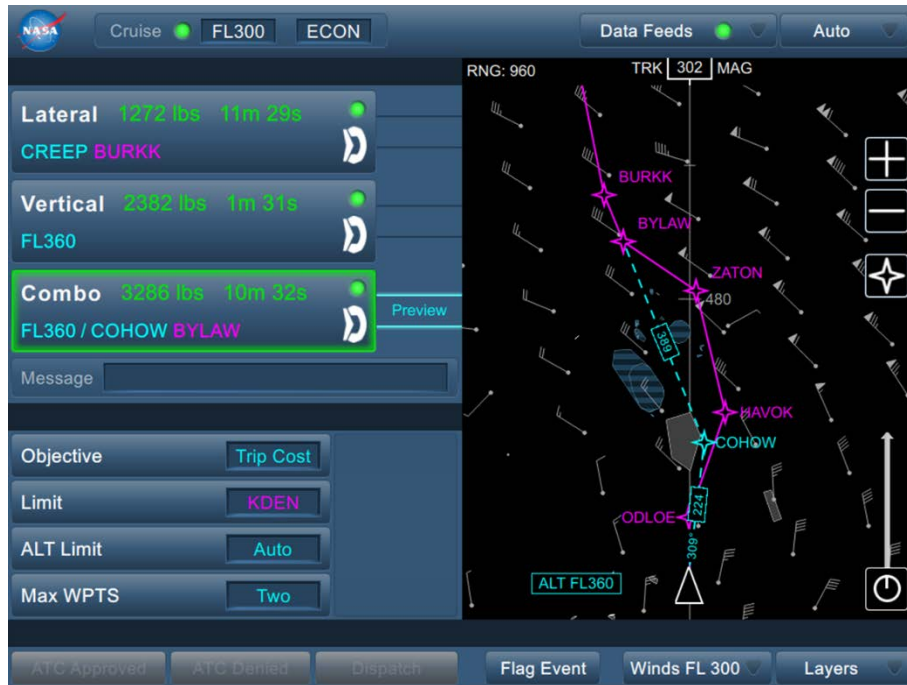

Figure 8. TAP v15-4 user interface shown in Auto Mode.

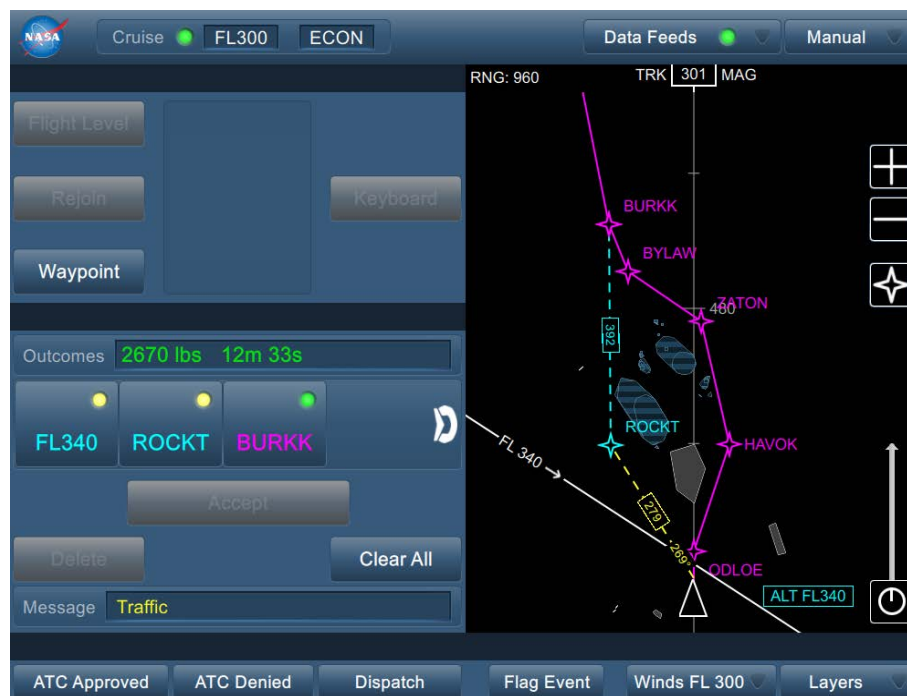

Figure 9. TAP v15-4 user interface shown in Manual Mode depicting a traffic conflict.

Technology Prototype

9.3. Features Enhancing Commercial Appeal for Technology Transfer

A number of distinguishing features were included in TAP’s design with the intention of increasing TAP’s appeal to be commercialized by industry vendors and widely adopted by the aircraft operator community. They include a flexible software architecture adaptable to a variety of host platforms and aircraft types, the use of industry standards where possible, and unique functionality that sets TAP apart as state-of-the-art route optimization technology worthy of industry and operator investment and adoption. Each of these features is described next.

9.3.1. Flexible System Architecture

TAP’s system architecture is shown in Figure 10. The TAP software is distributed among four “executable” software components all installed onboard the aircraft: TAP Engine, TAP Display, TAP Display Adaptor, and External Data Server. This distributed software architecture permits TAP to be hosted on a single EFB platform or, if desired, on several computing platforms connected by a Transmission Control Protocol / Internet Protocol (TCP/IP) local network. All four TAP software components can be compiled for Windows or Linux operating systems from a single code base, and the TAP Display can also be compiled for the iOS operating system for installation on the iPad (widely popular among airlines and business aviation as an EFB user interface).

TAP Engine is the main processor of TAP. It accepts and reads all data inputs, reformats them as needed for internal use, performs all processing necessary to generate route optimization advisories, and responds to all pilot commands on TAP Display that affect processing. Its central architecture, algorithms, and performance are derived from AOP. Its input processor was rewritten

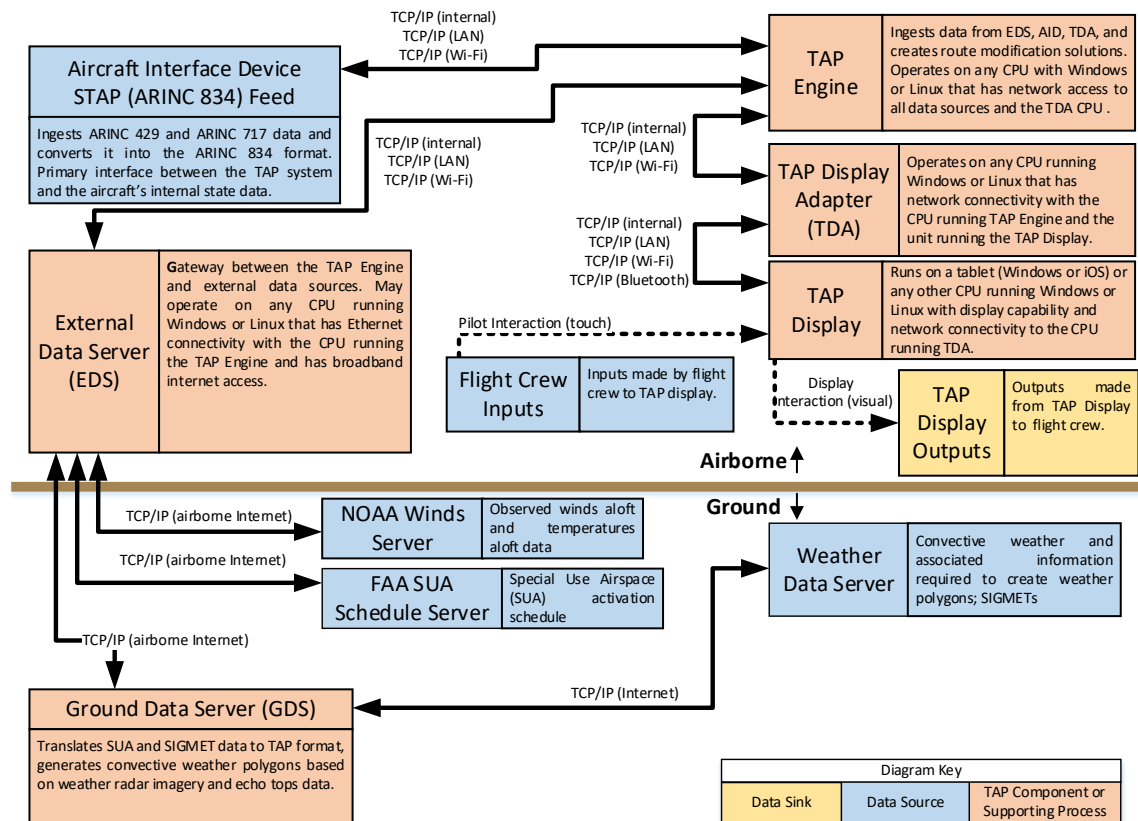

Figure 10. TAP’s distributed system architecture. Credit M. Underwood.

Technology Prototype

to receive avionics data via the ARINC 834 standard, or “Simple Text Avionics Protocol” (STAP), a communication protocol for non-certified EFBs to communicate with certified avionics.

TAP Display is the graphical user interface that enables the interaction between the pilot and the software. It displays TAP’s route optimization solutions, time/fuel outcomes, conflict characteristics, and additional information about the state of the system. TAP Display also accepts and implements entry of all pilot control instructions and is adaptable to many EFB configurations, operating systems, display aspect ratios, and device orientations.

TAP Display Adaptor (TDA) handles communications between TAP Engine and TAP Display. TDA receives all display-related data from TAP Engine, adapts it to the communication protocol of the hardware configuration, and sends it to TAP Display. It handles all pilot commands from TAP Display and relays them to TAP Engine. In configurations where TAP Display is operating on a tablet device, TDA also re-synchronizes connections with TAP Display after it has been put to sleep or pushed into background operation while another application is in use.

External Data Server (EDS) manages the connection, download, and processing of data from sources other than the ownship’s avionics via the STAP feed. Downloads implemented for the TASAR project included wind and temperature data from the Rapid Refresh service available from NOAA, SUA activation schedule from the FAA SUA website, and convective weather polygons from a NASA-based server connected to a commercial weather data service provider. EDS is designed to be expandable to incorporate additional data sources as desired.

9.3.2. Conformance to Industry Standards

As much as possible, TAP was designed to use industry standard interfaces and data formats to ease adaptation to many different aircraft types and configurations. Inputs for avionics data, navigation and airspace data, and atmospheric data all benefited from this approach, but exceptions needed to be made for weather and aircraft performance data.

Avionics Data Standards

Avionics data are accessed by TAP Engine via an ARINC 834 data feed in STAP format, a common standard for EFB applications to process avionics data. TAP contains an avionics data map that identifies which data elements are available on which port and from which “equipment code” (i.e., avionics device). Initially, TAP was capable of reading STAP data only from ARINC 429 avionics devices, but subsequently was updated with the capability of reading ARINC 717 avionics inputs, increasing the availability of data for future adaptations.

A critical data input required by TAP is route data from the FMS or similar system. TAP’s initial design was to process route data according to the ARINC 702A specification, the standard for advanced FMS typically installed in new generation transport aircraft. In fact TAP initially inherited AOP’s design to read ARINC 702A-3, an advanced version generally not yet used commercially, and so TAP’s design was “walked back” to the more common version ARINC 702A-1 which required TAP to work with less data content. As an example, ARINC 702A-3 provides route waypoint data with latitude/longitude coordinates and the waypoint name (typically three or five characters). ARINC 702A-1 provides only the latitude/longitude coordinates and no names, a critical shortcoming for TAP’s function of facilitating route modification requests via voice communications where waypoint names are a practical requirement. New functionality was therefore added in TAP to infer waypoint names by comparing the received route coordinates with

Technology Prototype

a published waypoint database. While effective, it requires the pilot to confirm the names were correctly inferred.

In preparing for the TASAR flight trials conducted in a Piaggio Avanti flight-test aircraft, it was necessary to adapt TAP to read route data in the format native to the aircraft's avionics: the General Aviation Manufacturers Association (GAMA) format. GAMA format differs from ARINC 702A-1 in that waypoint coordinates and names are provided, but only for the next eight waypoints. This created another adaptation challenge by excluding the destination airport from the transmitted route data for most of the flight. This information is required by TAP TG to build full trajectories, necessary in computing flight time and fuel burn to the destination for route optimization. The issue was resolved by requiring the pilot to enter the destination airport upon starting TAP. As a result, TAP now supports two route-data industry standards: ARINC 702A-1 and GAMA.

Another industry standard used by TAP is Display Traffic Information File (DTIF) as defined in ARINC 735B, the standard for traffic computers capable of supporting the display of ADS-B information. TAP uses the DTIF data to produce traffic-aircraft state vectors for use in near-term conflict detection by TAP CD. The underlying logic built originally in AOP CD supports traffic intent, and therefore TAP CD is readily adaptable to incorporating traffic intent data once it is available onboard.

Airspace Data Standards

Two datasets are pre-installed in TAP: airspace data that requires periodic updates, and aircraft performance model data that is fixed for a given aircraft type (e.g., 737-900ER). The airspace data includes published waypoints, airport elevations, and SUA geographical boundaries, and they are all derived from the Coded Instrument Flight Procedures (CIFP) dataset published by the FAA, updated on a 28-day cycle, and modeled to the ARINC 424 standard. The TAP software package includes a preprocessing executable routine that extracts the pertinent data from the massive CIFP and converts it to TAP's internal formats.

Aircraft Performance Standards

Unfortunately, aircraft performance is one significant area where an industry standard could not be adopted by TAP. The International Air Transport Association sponsors a Standardized Computerized Airplane Performance (SCAP) Task Force that has defined six specifications for aircraft performance (takeoff, landing, climb-out, inflight, noise, and aircraft performance monitoring) in an attempt to foster industry standardization. Some specifications (e.g., takeoff and landing) have indeed evolved into well-used industry standards, but the inflight performance specification is not widely used by aircraft manufacturers, who have opted instead to each use their own specifications. Some manufacturers even have different inflight performance specifications for different aircraft they offer. Furthermore, the Piaggio Avanti used for the TASAR flight trials had its aircraft performance data only available as numeric tables in the printed Pilot's Operating Handbook. Given that aircraft performance data comes in widely disparate formats (e.g., printed data, electronic data files) supporting a variety of modeling methods (e.g., kinematic, kinetic) and that aircraft behavior varies significantly among aircraft types (e.g., turboprops, jets), a novel approach was implemented for TAP aircraft performance modeling. Instead of following a single industry standard (which does not exist), TAP TG itself was designed to be easily adaptable to these variants. The method (described in reference [44]) separates aircraft performance behavior (e.g., the method an aircraft uses to achieve a climb, such as constant thrust or constant vertical rate) from the underlying math models, yielding a highly flexible, state-of-the-art approach to

Technology Prototype

aircraft performance modeling. The result is a single code base that can support multiple aircraft types, performance behaviors, and fidelity of available performance data. The capability was exercised multiple times in the course of the TASAR project by adapting TAP TG to three distinct aircraft types: the Piaggio Avanti (turboprop), the Dassault HU-25 Guardian (former business jet), and the Boeing 737-900ER (commercial transport).

In adapting TAP for the Boeing 737-900ER, the plan was to incorporate Boeing’s “Level 1” high fidelity aircraft performance dataset as supplied by Boeing to Alaska Airlines. (A similar approach was planned for the Airbus A320 in the partnership with Virgin America.) However, the Boeing Level 1 data were deemed critical sensitive data and not initially permitted to be used for this purpose. While an agreement between NASA and Boeing was eventually reached to allow its use, a backup plan was implemented instead to use the Base of Aircraft Data Version 4 (BADA 4) aircraft performance model through a license agreement acquired from Eurocontrol for the TASAR project. BADA 4 uses a single proprietary BADA 4 Specification in conjunction with a separate BADA 4 Dataset for each supported aircraft type. These elements were incorporated into TAP to conduct the Alaska Airlines operational evaluation but are not available for TAP licensing.

Atmospheric Data Standards

For representing wind and temperature data, TAP adopted the industry standard format used in meteorology for sharing gridded binary data, Gridded Binary Edition 2 (GRIB2). EDS retrieves these gridded data from NOAA in GRIB2 format and converts them to an internal format used by TAP Engine.

TAP did not use an industry standard for specifying the polygons representing convective weather, as three-dimensional (3D) polygonised products of this sort are not yet prevalent in the aviation weather data industry. The specification used by TAP is straightforward: a set of latitude/longitude vertices with floor and ceiling altitudes and start/end times of validity. Forecast polygons are represented by setting a future start time. Weather design considerations for TAP are presented in reference [45].

9.3.3. Unique Route Optimization Features

TAP is distinguished by several unique route optimization features that sets it apart from other tools as state-of-the-art technology worthy of commercial development and adoption. First and foremost is its location onboard the aircraft, where the pilot can devote substantial attention to route optimization during cruise flight, more so than a ground-based dispatcher responsible for dozens of current and future flights. This provides an opportunity to accrue greater savings, for example through frequent application of smaller route modifications, in addition to the less frequently available larger route modifications. Four additional features are highlighted below.

Multi-Objective Optimization

TAP’s route optimization capability is particularly powerful in that it supports not just one but a variety of optimization objectives, and the pilot can switch objectives during the flight while TAP is running. In addition to searching for flight time savings (useful if the flight is delayed or an unscheduled operation), TAP can also independently search just for fuel savings, which may be a more relevant objective if the flight is on time or early. Even more powerfully, TAP has a “trip cost” optimization objective option that combines time and fuel costs based on the Cost Index supplied with the flight plan. Whereas Cost Index today is typically fixed for a given flight, TAP’s capability unlocks the future potential for dynamically updating the Cost Index during the flight

Technology Prototype

based on changing priorities, or fine tuning it for a particular aircraft to gain the greatest optimization advantage, or even generating Cost Index as an additional TAP output to be entered in the FMS to help meet a desired arrival time as fuel-efficiently as possible.

These three optimization objectives (time, fuel, and trip cost) are meant only to be representative of the many more optimization objectives TAP could support. Thanks to the flexibility of TAP PBGA's fitness function, TAP can minimize or maximize essentially any mathematically definable function of arbitrary complexity, provided that the necessary data are available and processing is implemented to assess each candidate route against those data. For instance, using geospatial turbulence maps as an input data source (either gridded or polygonised data), a term could be added to the fitness function to include ride quality as an additional factor in route optimization (e.g., balancing passenger comfort against trip cost). This illustrates TAP's tremendous potential for expansion as a sophisticated airborne trajectory management tool.

Multi-Dimensional Optimization

Another unique and compelling feature of TAP is its capability for route optimization in multiple dimensions. TAP produces three solution types: optimizing just the lateral path, just the cruise altitude, and (particularly unique) an independently optimized combination of lateral path and cruise altitude. This third solution type can be effective in several ways, for example, finding the most efficient lateral path to request at the most wind-friendly altitude, or making a desired altitude feasible that was otherwise blocked by traffic by "sidestepping" the traffic. Even the vertical solution (which recommends a cruise altitude change while keeping the current lateral path) has particular merit. Pilots typically use two methods to determine when to perform a step climb, a common action on longer flights as the aircraft becomes lighter. One method is to climb at the waypoint indicated in the flight plan, determined well before departure using (now old) wind forecasts, fuel burn estimates, and aircraft performance data. The other method (often in combination with the first) is to consult the FMS for its recommended optimum altitude, computed dynamically but without reference to the aircraft's future trajectory or wind field. In contrast, TAP uses up-to-date wind data and full trajectory integration to determine the optimal cruise altitude. Pilots can use TAP to validate the flight plan's step climb waypoint recommendation or to make a decision to advance or delay the climb to the FMS optimum altitude, given TAP's incorporation of the effect of updated winds integrated along the entire trajectory.

Common and Uncommon Optimization Solutions

TAP is also distinguished by its ability to find non-obvious route modifications, that is, those that would not normally occur to a pilot such as the common request to "go direct" (i.e., make a short cut) to a downstream FMS waypoint. Using the power of its genetic algorithm, TAP explores a broad spectrum of candidate route modifications that include those simple "directs" but go much farther by exploring hundreds of non-direct routes through additional waypoints in the airspace before rejoining the FMS route at various potential locations. To further increase the search options, the published waypoints TAP uses in its search also include the Navigation Reference System (NRS) waypoints defined by the latitude-longitude grid. This extensive search of candidate route modifications account for winds and various constraints (e.g., traffic, weather, and SUA) and converge through a generational "survival of the fittest" contest to produce the most optimal, conflict-free solution. Figure 11 shows an example of a non-direct solution that saves fuel. While the TAP prototype constrained its solutions to published waypoints to facilitate voice requests and hand entry into the FMS, the underlying TAP algorithms derived from AOP work with arbitrary

Technology Prototype

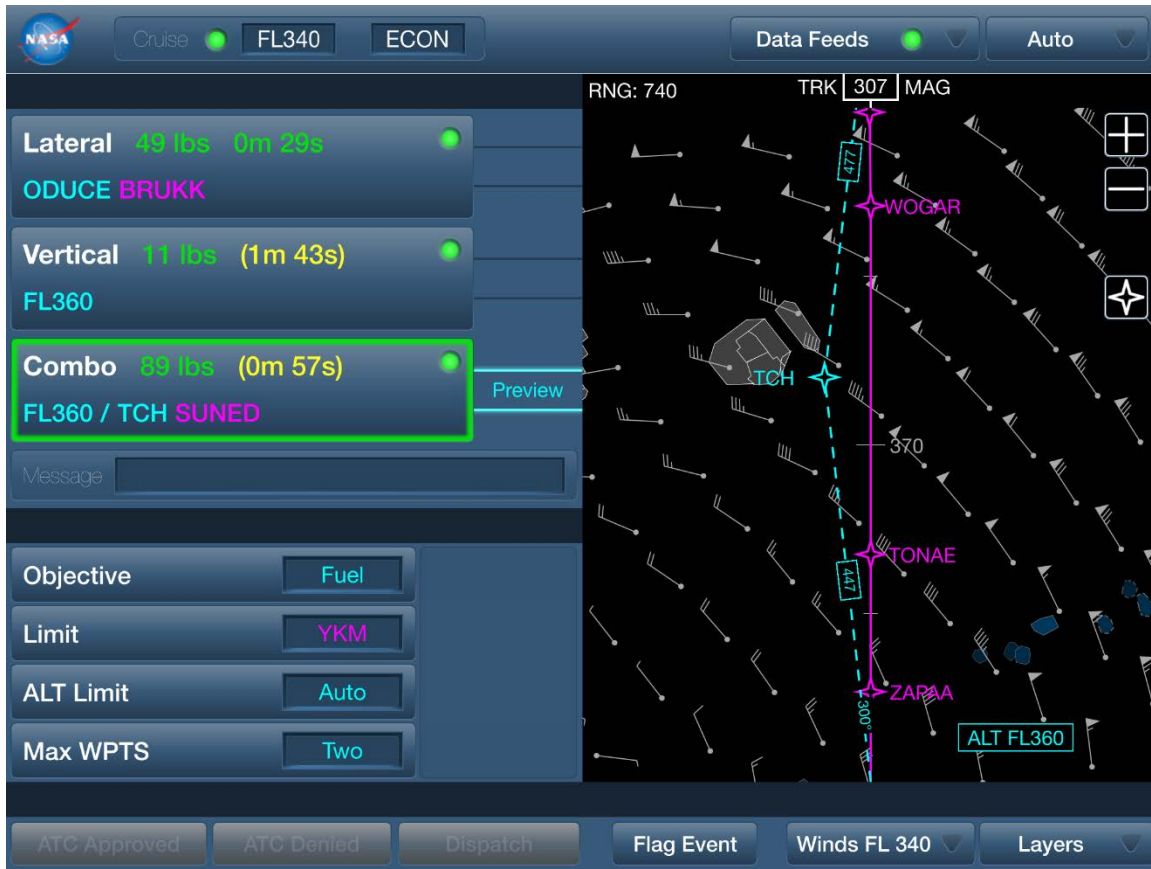

Figure 11. Beneficial non-direct route modification identified by TAP's genetic algorithm.

latitude/longitude coordinates. This capability can be unleashed in future implementations where TAP is connected to avionics with the ability to push route modifications to the FMS and to ATC through Data Comm. This will also be the opportune time to expand TAP PBGA pattern templates to include more complex route structures.

Traffic-Aware Benefits

A significant innovation in TAP is the integral use of ADS-B traffic data without a certified Cockpit Display of Traffic Information (CDTI). Most ADS-B applications require a CDTI as an integral part of performing some operational function. Whether for maintaining positional awareness in reduced visibility or to enable the pilot to verify a selected target for an in-trail procedure or interval management, the CDTI places a traffic symbol relative to the ownship on a map display. Due to safety implications, certification of such traffic displays increase the cost of system implementation and could be a hidden barrier for adopting TASAR (a non-safety-critical application). To reduce such potential barriers of adoption, TAP only includes traffic data in its route optimization processing. The only displayed indications of traffic are (1) the message "TRAFFIC" if TAP CD determines the route modification has a traffic conflict, and (2) a display of the state vector and altitude of the traffic aircraft, but not its position. Figure 9 (p49) shows an example of these indications. Their purpose is to advise the pilot against making the ATC request due to the potential conflict with traffic. They also provide just enough indication of whether the conflict is temporary (e.g., traffic that is crossing or climbing/descending) or long term (e.g., traffic that is parallel and level), which can aid in a pilot's decision to briefly hold the request until the

Technology Prototype

indications clear or to pursue other options. Using this “traffic aware” feature of TAP to time the request to ATC could yield significant benefits in more often achieving approval for the desired route modification than having it denied.

Though ADS-B is not strictly required by TAP to produce route optimization solutions, it is highly important in another respect: pilot acceptance. The more ATC approves route modifications derived from TAP, the more likely pilots will continue to use TAP and the more benefits will accrue. Conversely, more denials will likely reduce usage and benefits. While traffic is not ATC’s only consideration in approving route modification requests, separating traffic is their primary function. Accommodating traffic in route modification requests is therefore the most impactful method for increasing likelihood of ATC approval and thus in achieving the full benefits of in-flight route optimization. It is unlikely that any ground-based route optimization tool can match TAP’s performance in this respect, given TAP’s access to real-time ADS-B data and its role directly supporting the pilot who actually makes the request to ATC. This underscores the power and commercial potential of airborne route optimization technology: leveraging its access to relevant and timely data on the aircraft and operating environment, presenting to the pilot a range of viable optimization alternatives, and becoming an integral part of the strategic decision making of pilots as they transform into proactive trajectory managers.

10. Human Factors Assessment

Embedded directly in the TASAR acronym is the word “Aircrew” referring to the aircraft flight crew, i.e., the pilots. Including the pilots in TASAR’s name purposefully highlights the essential role they fulfill in the TASAR concept. Whereas software technology clearly has a central function in enabling cockpit-based route optimization, the pilots themselves ultimately make the decision of whether to optimize the route and what route modification requests to make to ATC. In other words, the role of the technology is not just to make aircrew requests more strategic but also to empower aircrews themselves to be more strategic and to grow into the role of proactive trajectory manager. To achieve this vision in the long term, the TASAR technology in the near term must successfully be integrated into the cockpit environment as a useful tool and be accepted by pilots as an integral part of their decision-making process. These requirements dictate that special attention be paid in this project to *human factors* that reflect the pilot’s interaction with and experience using the TASAR technology and that enable the pilot’s critical role in achieving operational savings through TASAR. Human factors will figure significantly in the level of success TASAR achieves in its early operational implementation.

Activities throughout the project included a focus on human factors. The intention from the outset was to pursue an iterative, human-centered, design and evaluation process as the technology matured through a series of simulation experiments, flight trials, and an airline operational evaluation. Each step in the process would produce human-centered improvements to the technology and a set of artifacts documenting the findings of human factors assessments, in case they were needed for receiving operational approval. The activities described in this chapter focused specifically on human factors. As subsequent chapters indicate, human factors remained an important and ongoing element in maturing the TASAR technology through multiple flight trials and the airline operational evaluation.

Presented in this chapter are high-level summaries of two HITL simulation experiments conducted at the University of Iowa’s Operator Performance Laboratory. The assessments were conducted in a fixed-based flight simulator of a Boeing style, transport aircraft flight deck with TAP integrated into the simulator as an EFB application. Long-distance flight scenarios through U.S. domestic airspace were generated for the experiments, and they included regions of dynamic weather that generated multiple opportunities for the pilot to use TAP. This research environment enabled structured study of several human-factors issues. The first simulation experiment, HITL-1, focused foremost on issues potentially impacting TASAR operational approval – pilot workload and distraction – while also assessing the design and usability of an early prototype of the TAP user interface. The second simulation experiment, HITL-2, incorporated a major design update to the TAP user interface. Conducted in preparation for the upcoming airline operational evaluations, HITL-2 validated a Computer-Based Training (CBT) tool developed for TAP, evaluated TAP’s impact on other uses of the EFB, and assessed the design and usability of the updated TAP user interface.

Human Factors Assessment

10.1. TASAR Human-in-the-Loop Simulation 1

10.1.1. Objective

The purpose of HITL-1 was to assess the usability of TAP on a commercial airline flight deck and to determine the level of interference, if any, that TASAR introduced to the normal working environment of the flight deck. The usability assessment was important for determining whether TAP's functions and interface design would be operationally acceptable and effective for airline pilots. Assessing the potential for cockpit interference would inform any concerns for operational approval, with the results of HITL-1 serving as valuable artifacts for approving officials should they be desired. HITL-1 was conducted in August 2013.

Two potential interference areas were of specific interest in HITL-1. One was the effect that the presence of TAP in the cockpit would have on pilot workload. Though en route flight is generally considered low workload for airline pilots on highly automated, modern commercial transport aircraft, there are times during en route flight when workload could increase, for instance when flying in areas of convective weather. While TAP is not a weather avoidance tool, it is an additional system within the pilot's scan pattern that could have an adverse effect on workload. The simulation experiment presented an opportunity to quantify any such effect. The other item of interest regarding interference was the potential for TAP to distract the pilot from monitoring flight-deck systems for off-nominal events. TAP is hosted on the pilot's EFB, normally located outside the forward field of view. If the pilot is fixated on the EFB for significant periods of time, the forward displays may receive less attention, potentially causing an impact on the pilot's monitoring of aircraft systems. In the simulation environment, off-nominal events could be safely induced to assess any distracting effects of TAP.

10.1.2. Method

Twelve participants, all active airline pilots, were used in the HITL-1 experiment, one for each day of simulation runs. Each pilot flew two flights each lasting approximately 2.5 hours, one flight with TAP and one flight without TAP. The simulation facility, shown in Figure 12, was a fixed-based simulator representative of a commercial transport flight deck. For HITL-1, the EFB hardware was a Goodrich SmartDisplay™ Class 2 EFB mounted on the left side of the Captain's station. TAP was installed on the EFB and was connected to the simulator's avionics data through an emulated ARINC 834 data server. The subject pilot sat in the Captain's seat and, in addition to operating TAP, performed "pilot flying" (PF) duties. These duties included exercising control of the aircraft, selecting the most appropriate flight path, initiating and performing checklist items, and approving/executing FMS changes. Serving as First Officer in the "pilot monitoring" (PM) role was a "confederate pilot," an employee of the simulation facility with a scripted role. The PM assisted the PF with any requests and



Figure 12. Flight simulator with TAP v2 on the Captain's EFB. Photo by M. Cover.

Human Factors Assessment

questions as a minimalist crew member. The duties of the PM included calling out the checklist items, monitoring the execution of the checklist, managing dispatch communication, handling the ATC radio calls, and making all FMS entries except execution. A confederate air traffic controller monitored the aircraft and the local simulated traffic from a station outside the simulator and provided approvals and denials of route modification requests as dictated by the design of each use case. The role of dispatcher was scripted, with messages being received by the PM and relayed to the PF.

The simulated flight consisted of a partially flown, transcontinental route from New York (JFK) to Los Angeles (LAX), traversing airspace impacted by convective weather. Figure 13 shows the purposefully inefficient flight-plan route that conservatively accommodated the weather. Designed into the flight were five sequential TASAR “use cases” listed in Table 9. Each use case was based on a weather-related condition that required a route change, either initiated by the pilot or by dispatch. The pilots experienced all five use cases on both flights, regardless of whether TAP was available for the flight, though they were presented in a different order on the two flights.



Figure 13. Simulated TASAR flight for HITL simulation experiments.

Table 9. TASAR use cases exercised in HITL-1.

USE CASE	TAP Mode	Participant Information Source/Action
1	AUTO	The wind at the current ownership altitude is suboptimal for the direction of flight; however winds at another altitude are more favorable for the direction of flight. TAP offers alternatives based on change for more favorable winds.
2	AUTO	A convective weather pattern earlier in the flight caused a reroute; however, this weather pattern is now dissipating making the original route a more efficient route. TAP offers alternatives. Reroute initiated based on dissipating convective weather polygon, inviting a more favorable route.
3	MANUAL	Dispatch sends a message to the aircraft to request a reroute to waypoint “ABC” and then to “DEF” when able. “ABC” is an off-route waypoint and “DEF” is on the active route. Pilot evaluates dispatch request in TAP and requests route change.
4	MANUAL	ATC issues a hazardous weather broadcast to indicate moderate to severe turbulence in the region ahead of the aircraft at the current altitude; however other altitudes are reporting only light chop. Pilot manually enters and evaluates alternatives in TAP, requests reroute.
5	MANUAL	The flight needs to avoid weather cells, and the pilot would like to request to deviate. Pilot evaluates possible alternatives in TAP to avoid weather and requests reroute.

Human Factors Assessment

For flights with TAP, the first two use cases were designed to trigger use of TAP in Auto Mode, in which TAP monitors for optimization opportunities and presents them to the pilot. In this early version of the TAP software, use of Auto Mode involved two interface screens, as shown in Figure 14. The first screen (a) presented the optimization solutions in the lateral, vertical, and combo dimensions, and the second screen (b) displayed the optimization solution selected by the pilot.

The remaining use cases were designed to trigger use of TAP in Manual Mode, in which the pilot builds a route modification for TAP to evaluate time and fuel outcomes and to determine whether the route modification conflicts with traffic, weather, and SUA. The Manual Mode user interface of this early version of TAP is shown in Figure 14(c).

A single “off-nominal condition” was presented in a single use case of each flight. The off-nominal condition was representative of a relatively rare event that the crew needed to recognize and manage but was not so severe as to force an emergency. This off-nominal event comprised a fuel-imbalance evolution that required performance of an appropriate checklist and several fuel-system manipulations. The alignment of the off-nominal condition with the use cases was rotated through all five use case possibilities across the twelve participants. The use cases without the off-nominal condition were considered nominal conditions. Restricting the off-nominal condition to a single use case in each flight and changing the order of use cases between flights minimized the likelihood of learning effects.

The independent variables of the experiment were TAP availability (TASAR ON and TASAR OFF) and flight condition (nominal or off-nominal), arrayed in a two-by-two, within-subjects experimental design. The five use cases were included as mechanisms to trigger reroute decisions but were not treated as independent variables in the experimental design.

The dependent variables (i.e., the measurements of the experiment) included several groupings of system metrics. Timing metrics recorded the time to detect and respond to events such as a TAP

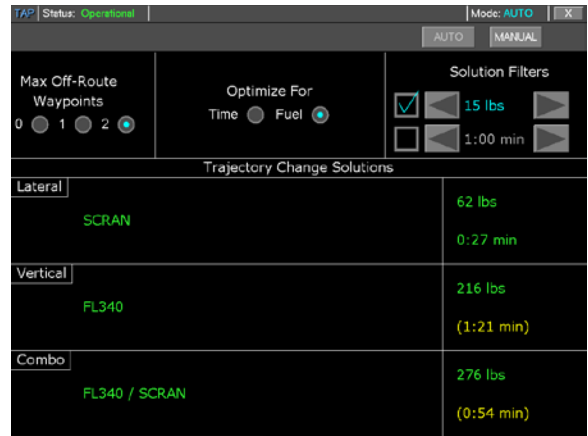

(a) Auto Mode screen.



(b) Selected optimization screen.



(c) Manual Mode data entry interface.

Figure 14. TAP v2 user interface tested in HITL-1.

Human Factors Assessment

reroute advisory or the off-nominal condition (i.e., fuel imbalance). Timing data were collected using an eye tracking system in the simulator. The eye tracking system was also used to measure region-of-interest metrics, indicating the time the participant spent looking at different areas in the cockpit. A workload metric assessed the pilot's cognitive loading in self-reported subjective terms via a standardized workload survey completed by the pilot after each use case. An objective workload metric derived from electrocardiogram measurements was obtained but later removed from the analysis due to concerns regarding the metric's validity. Two additional standard surveys assessed the pilot's perceived ratings of SA and TAP system usability and were supplemented by a questionnaire on TAP's functions and user interface.

10.1.3. Results

The following are the high level results from HITL-1. A complete description of the experiment design, methods, apparatus, analyses, and results are presented in reference [47]. In the summaries below, objective results are presented first, followed by subjective results.

On average it took pilots 87 seconds after the use case trigger event occurred to detect TAP's display of a new route modification advisory, and an additional 83 seconds to initiate a request to ATC. These response times are reasonable and acceptable for non-urgent events on an airline flight deck operating in nominal conditions.

For the off-nominal condition, measurements quantified pilot promptness in detecting the presence of the off-nominal condition, making the correct decision, and executing the correct actions. Comparisons were made between the TASAR ON and TASAR OFF flights. There was no statistically significant difference in response time to the off-nominal event when TASAR was ON when compared to when TASAR was OFF. This indicates that TASAR did not interfere with the detection of this flight-critical, off-nominal event.

An additional distraction concern was that the presence of TAP could potentially disrupt the standard eye-scanning pattern of the pilot on the flight deck. Using the eye tracker, the percentage of gaze occupancy within selected areas of interest (Primary Flight Display (PFD), Multi-Functional Displays, Mode Control Panel, EFB, and outside view) was assessed continuously across the flight. (Limitations of the eye tracking installation resulted in times when eye tracking was lost. Therefore, the data collected had instances when data was not present.) The largest percentage of recorded glance time was to the Captain's PFD, an expected result given the flight-critical nature of the information on the PFD. There was no statistical difference in glance occupancy percentage to the PFD when TASAR was ON when compared to when it was OFF, providing evidence that TAP did not interfere with the pilots' normal aircraft instrument scan.

Subjective measurement of pilot perceived workload, using a standard workload survey administered after each use case, indicated a small but statistically significant workload increase between TASAR OFF and TASAR ON conditions. As a practical matter, the increase was not significant, as the mean workload ratings were very low: 1.25 (TASAR OFF) and 1.60 (TASAR ON) on a 10-point Bedford scale. Looking specifically at the use cases with the off-nominal condition, the analysis did not indicate a statistically significant difference in pilot perceived workload with TASAR ON versus TASAR OFF. Similar subjective measurements of pilot SA showed no statistically significant effect from the presence of TASAR.

Pilots completed a system usability survey following each use case in the TASAR ON condition. Mean ratings of approximately 87 on a 100-point scale were recorded for both Auto Mode and

Human Factors Assessment

Manual Mode, with no statistically significant difference between the two modes. The scores represent a user preference baseline to serve as a comparison with future versions of the TAP user interface. Pilots also completed a post-simulation questionnaire which indicated that the participants found the TAP user interface easy to work with, useful, and easy to understand. Feedback on specific areas of the TAP user interface design were incorporated into an updated design tested in HITL-2 and ultimately used in the airline operational evaluation.

In summary, HITL-1 indicated no adverse effects of TASAR on human factors affecting operational approval such as workload and distraction. While pilots gave high ratings to the design and usability of the TAP user interface, several pertinent recommendations triggered a design update that was subsequently evaluated in HITL-2.

10.2. TAP User Interface Design Update

The project context that spawned a second HITL simulation experiment was the emerging opportunity to conduct an airline operational evaluation of TASAR. Information gathered from HITL-1 and FT-1 resulted in human-factors design improvements to the TAP user interface, many of which were implemented in a significant redesign that also brought the user interface more in line with the style and features common to tablet-based EFB “apps.” Adapting TAP to a tablet platform was motivated by the discovery that many prominent airlines were adopting the iPad as their EFB interface of choice. It became clear that if TAP was to be considered relevant in the EFB industry, it would need to be compatible with the iPad. This was confirmed through outreach activities and by one of the most frequent comments from FT-1 participants: “Let us know when TAP is available for the iPad.” Alaska Airlines being among those adopting the iPad as their EFB was the deciding factor in moving forward with the redesign. However, since the iPad was not a ubiquitous EFB selection among airlines (Virgin America, for one), maintaining cross-platform compatibility with Windows® and Linux operating systems was critical to the strategy of making TAP widely adoptable in the industry. A cross-platform development approach using the open-source software development toolkit known as Qt was selected, which provided an opportunity to completely refresh the design of the user interface, this time with specific intent to incorporate human factors design principles to enhance TAP usability and appeal without compromising pilot workload.

The updated user interface design, shown in Figure 15, incorporated several functional changes in addition to the clearly more intuitive, user-friendly styling. First was the addition of an interactive “Startup Checklist” screen, made necessary to accommodate data interface characteristics of Alaska Airlines’ B737-900ER aircraft. The existing data interface lacked several key data parameters needed by TAP for trajectory processing and solution display, therefore requiring the pilot to manually input these parameters. In particular, the FMS route data excluded such items as origin, destination, waypoint names, Cost Index, cruise altitude, and cruise speed. The Startup Checklist screen was created to enable the pilot to make these entries, and in the case of waypoint names, to verify inferred data (e.g., waypoint names inferred from supplied latitude/longitude coordinates and an installed waypoint database). Other items on the screen enabled the pilot to confirm system status information (e.g., TAP version, connection status, and databases) and to set an optimization parameter.

The most substantive user interface changes for Auto Mode were consolidation into a single screen and the inclusion of a “visualization panel” or map showing a more complete depiction of the FMS active route, along with TAP route-modification advisories or “solutions.” The

Human Factors Assessment

redesigned interface was more graphical than the previous text-oriented interface, allowing preview and selection of any of the three solution types. It was also more user-interactive and information rich with the ability to zoom and show data layers including a depiction of winds, weather polygons, and SUAs. The specific purpose of these display layers, which were added based on feedback from HITL-1, was to help the pilot interpret, understand, and accept TAP advisories.

In accordance with FAA standards in effect at the time, the own aircraft (“ownship”) position was not displayed but could be inferred as being at the bottom center of the map display in its default “track up” view. An alternate “north-up” view was also selectable, with buttons allowing the user to step through the route waypoints. The interface update added the ability to specify a limiting optimization waypoint and removed the solution filters which pilots in HITL-1 and FT-1 said were unnecessary. It also added a data-feeds status menu and cruise-settings windows where these values entered on the Startup Checklist could be monitored and updated. Finally, it added a message bar that displays processing status, conflict information, and other system indicators for the user.

The Manual Mode screen also underwent a significant update by mirroring the graphical style of the Auto Mode screen, retaining many common elements, and completely redesigning the method for entering off-route waypoints. Whereas the previous method was to specify a bearing and distance from the ownship via text entry, the updated method allowed the pilot to touch the desired location on the map, from which TAP would locate the nearest published waypoint to that location. Keyboard entry by waypoint name (via an onscreen keyboard) was also provided, if a specific known waypoint is desired. A “tray” contained each element of the proposed route change as a button that could be selected, edited, or deleted. The rejoin waypoint and flight level buttons triggered scrollable windows to select the appropriate entry.

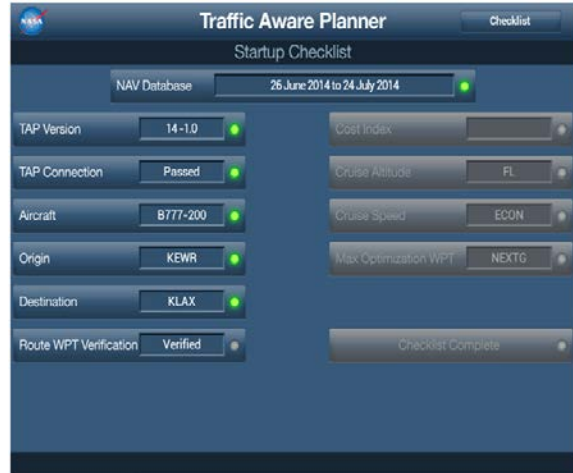

(a) Startup Checklist screen.



(b) Auto Mode screen.

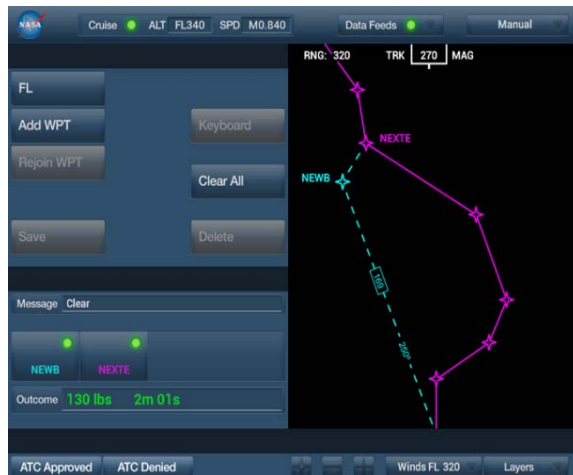

(c) Manual Mode screen.

Figure 15. TAP v14-1 user interface tested in HITL-2. TAP v15-2 used a similar design.

Human Factors Assessment

An architectural change to TAP was also made at this time to allow the TAP Display, as a tablet application, to “sleep” or move to the background while the pilot uses another app on the tablet EFB. The only visible effect on the user interface was a brief “refresh” of data upon returning to TAP.

10.3. TAP Training Materials

In an effort to reduce as many barriers as possible to airlines adopting the TAP software, as well as to facilitate the upcoming airline operational evaluations, TAP training materials were

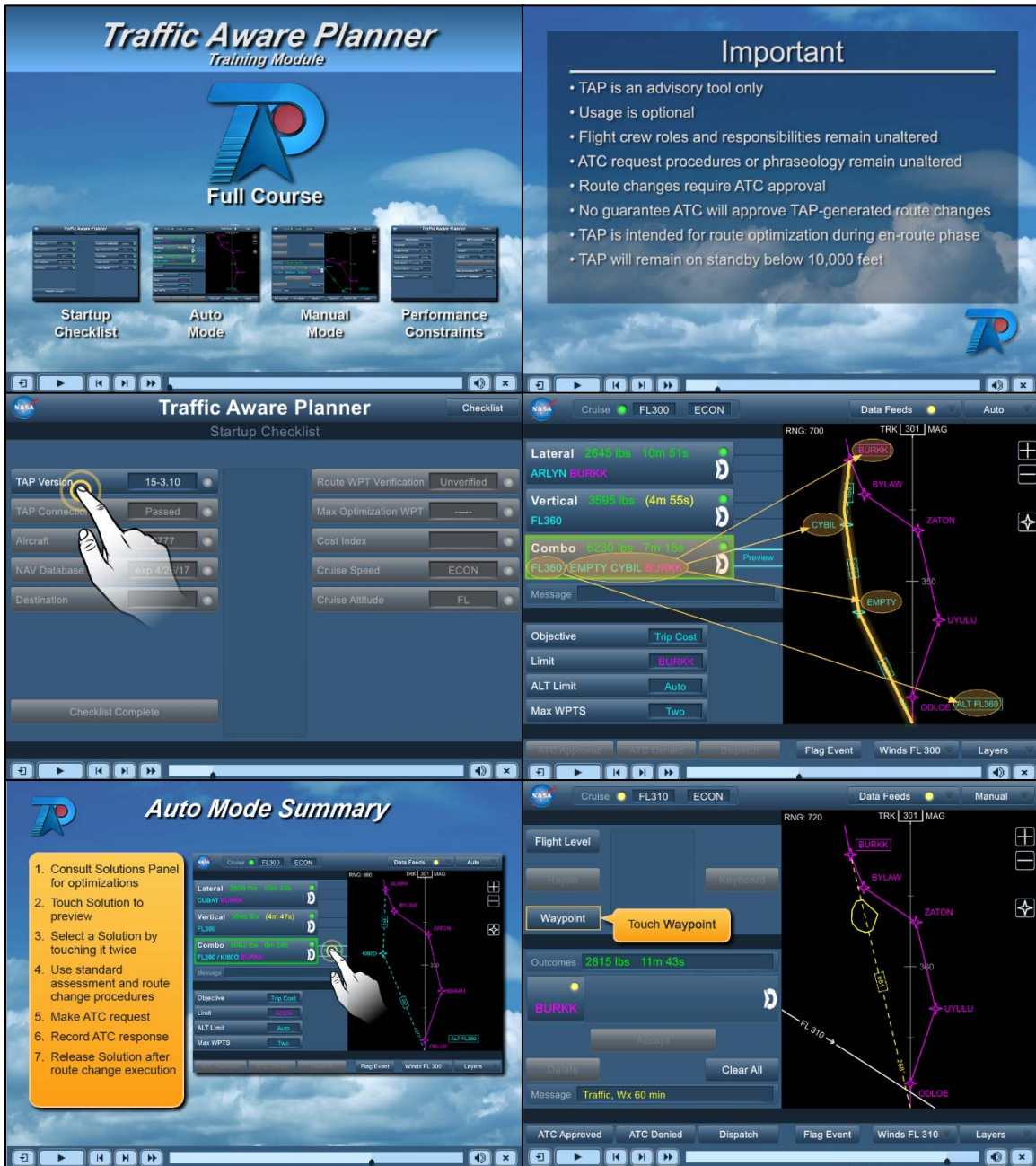

Figure 16. TAP Computer-Based Trainer.

Human Factors Assessment

developed to provide detailed instruction and reference material for pilots on the features and use of TAP. FAA policy requires pilot training on EFB applications, though the method of training is generally left up to the operator. Training costs can be a barrier to technology adoption, and so every effort was made to generate materials suitable for the training requirement to minimize airline expense and adoption delay. The three TAP training materials developed by NASA were an Operating Procedures Handbook, a Flight Manual Bulletin, and a CBT (Figure 16). The expectation was that airlines would use the CBT as the primary training tool and provide the documents as supplemental written reference material available onboard the aircraft. The Flight Manual Bulletin is a brief synopsis of TAP's primary screens and functions. The Operating Procedures Handbook is a detailed reference guide for TAP, providing company guidelines and policy, a TAP system overview, detailed procedures for each TAP operating mode, and additional information.

As the primary training tool, the TAP CBT was designed to give comprehensive instruction on TAP's user interface features and interpretation of key elements of displayed information. An interactive CBT format was chosen over a more traditional training methodology to enhance knowledge transfer and retention [48]. Considerable effort was also put forth to encompass the key training topics in as compact a CBT product as possible to further minimize training-time costs for adopting airlines. Based on partner airline guidance, CBT duration of about 30 minutes was targeted. Multiple iterations of the CBT were developed over the life of the project, with enhancements made as TAP's user interface matured.

10.4. TASAR Human-in-the-Loop Simulation 2

10.4.1. Objectives

The second HITL simulation experiment was prompted by the likelihood of two airlines conducting operational evaluations of TAP within the next few years. In preparation for these evaluations, HITL-2 was chartered with three primary objectives. First was to evaluate the significant design update of the TAP user interface to ensure adequate usability and to assess any impact on the findings from HITL-1 regarding workload and distraction. Though no adverse impact on these findings were expected because the intended function and capabilities of TAP were largely unchanged, the redesigned user interface could attract increased pilot attention given the additional information displayed. It was considered prudent to experimentally verify the HITL-1 findings, given that the airlines would be conducting operations with the updated user interface.

Second was to assess how TAP usage might affect other operational uses of the EFB. Airlines use EFBs for a variety of purposes, such as viewing charts, weather information, aircraft manuals, logbooks, and checklists. While accessing other apps, TAP would be running in the background but not visible to the pilot, potentially affecting the pilot's propensity to use it. Similarly, TAP's presence as a compelling EFB application might interfere with the accomplishment of other tasks that make use of other EFB applications. The experimental setting of the simulator would provide the opportunity to assess these interactions prior to the operational evaluation.

Third was to determine an effective means for training a large number of airline pilots on TAP. The operational evaluation could potentially involve many hundreds of pilots cycling through the TAP-equipped aircraft. Effective training could mean the difference between success and failure of the operational evaluation in the near term, and operational benefits from TASAR in the long term. While the FAA requires airlines to provide pilot training on EFB applications, the training

Human Factors Assessment

method is not specified. Training could be provided through a simple bulletin. Given the unique interactive nature of the TAP application as compared to other EFB applications that present largely static data, and given the critical role of the pilot in the success of the TASAR operational evaluation, the NASA team developed the TAP CBT to maximize the likelihood that TAP would be used properly and provide the best possible results. The experimental objective, therefore, was to determine the efficacy of CBT training relative to instructor-led training that allows for personal tailoring.

10.4.2. Method

HITL-2 was conducted in October/November 2014 at the University of Iowa Operator Performance Laboratory, using essentially the same flight simulator apparatus used in HITL-1 but with the exception that TAP was displayed in HITL-2 on a Dell Venue Pro 11 tablet. The intended experimental methodology was to replicate the conditions, scenarios, and data collection used in the TAP flights of HITL-1, allowing a between-experiments comparison of usability, workload, and distraction between the two user interface designs. Unfortunately, a significant amount of experimental data loss occurred in HITL-2, limiting the analyses that could be performed. The off-nominal condition in HITL-1 (i.e., fuel imbalance) was inadvertently not replicated in HITL-2, making a comparison of distraction effects not possible. The objective workload metric derived from electrocardiogram measurements was removed from the analysis due to concerns regarding the metric's validity. In addition, eye-tracking data collection errors precluded analyses of timing and region-of-interest metrics. Like HITL-1, HITL-2 was a fully contracted activity. The experiment design was overseen by NASA and was reviewed through the Crew Systems and Aviation Operations Branch experiment review process. Both a dry run and a dress rehearsal were performed, although without NASA onsite presence to save resources and to enable similarity to the upcoming data collection environment. Despite these preparations, numerous stressors (financial, personnel, and technical) affected the contractor experiment team in the months and weeks prior that may have contributed to some of these oversights during data collection. In retrospect, although the contractor reported readiness for experiment execution, a cautionary pause prior to data collection to ensure these issues were adequately addressed might have reduced these errors. Nevertheless, some comparisons between the experiments were possible and are presented below.

Similar to HITL-1, the simulation runs in HITL-2 were organized into two cross-country flights (of which ~2.5 hours were flown), but with both flights this time being TASAR ON flights. The TASAR OFF condition of HITL-1 was not replicated in HITL-2. The flight scenarios were identical to those in HITL-1 with the exception of the off-nominal condition which was not replicated. The first flight represented a "TAP-only" condition (same as HITL-1, "TASAR ON"), and the second flight added special events each requiring the use of a second EFB application in addition to TAP ("TAP+2ndApp"). The five use cases embedded in the TAP-only flight were the same as HITL-1 and are shown in Table 9 (p59) and the third column of Table 10. For the TAP+2ndApp flight, the special events added to the use cases to trigger the use of a second EFB application (different app for each event) are shown in the fourth column of Table 10. An additional take-off use case was also added to HITL-2 to exercise a new "cruise settings" interface function in TAP.

HITL-2 included 12 airline pilot participants, none of which had participated in HITL-1. As preparations were underway for conducting the TASAR operational evaluations, both airlines

Human Factors Assessment

Table 10. TASAR use cases used in the second flight in HITL-2.

USE CASE	TAP Mode	Participant Information Source/Action	Special Event
Take Off	N/A	Pilot adjusts flight level in TAP after ATC assigns a different altitude as final than originally planned until aircraft is out of New York center. Pilot should recognize on own or recognizes amber light on TAP.	None
1A	AUTO	The wind at the current ownship altitude is suboptimal for the direction of flight; however winds at another altitude are more favorable for the direction of flight. TAP offers alternatives based on change for more favorable winds.	ATC requests pilots to go into a hold for ~10 minutes while an issue with the center radar is fixed. Pilots look up fuel burn rate tables to ensure there is enough fuel to reach destination.
2A	AUTO	A convective weather pattern earlier in the flight caused a reroute; however, this weather pattern is now dissipating making the original route a more efficient route. TAP offers alternatives. Reroute initiated based on dissipating convective weather polygon, inviting a more favorable route.	A medical situation is radioed up to the cockpit from the lead flight attendant. Pilot initiates the MedLink checklist to follow procedure with dispatch and the doctors on the ground.
3A	MANUAL	Dispatch sends a message to the aircraft to request a reroute to waypoint "ABC" and then to "DEF" when able. "ABC" is an off-route waypoint and "DEF" is on the active route. Pilot evaluates dispatch request in TAP and requests route change.	None
4A	MANUAL	ATC issues a hazardous weather broadcast to indicate moderate to severe turbulence in the region ahead of the aircraft at the current altitude; however other altitudes are reporting only light chop. Pilot manually enters and evaluates alternatives in TAP, requests reroute.	ATC requests pilots to go into a hold for ~10 minutes while an issue with the center radar is fixed. Pilots look up fuel burn rate tables to ensure there is enough fuel to reach destination.
5A	MANUAL	The flight needs to avoid weather cells, and the pilot would like to request to deviate. Pilot evaluates possible alternatives in TAP to avoid weather and requests reroute.	Dispatch notifies crew of disabled aircraft at destination airport that has temporary closed the main runway. Crew evaluates alternate airports in case the disabled aircraft cannot be removed in time of arrival. Involves looking up landing performance for weight and runway conditions.

supplied multiple pilots to participate in HITL-2: five pilots from Virgin America, and four pilots from Alaska Airlines. To evaluate the CBT efficacy as a standalone pilot training tool, six of the 12 pilots were given instructor-led training in a presentation format, and the remaining six were given the CBT without instructor-led training.

The independent variables of the experiment were TAP user interface (a 1x2 between-experiments comparison of initial and revised user interface designs), EFB multi-tasking (a 1x2 within-subjects comparison of TAP-only and TAP+2ndApp), and TAP training method (a 1x2 between-subjects comparison of instructor-led training and CBT training). As indicated earlier, an

Human Factors Assessment

inadvertent omission from HITL-2 of the off-nominal event (fuel imbalance) precluded a between-experiments verification that the updated TAP user interface design does not induce distraction from normal flight deck duties. However, the special events introduced for the EFB multi-tasking assessment were all higher criticality duties relative to route optimization and therefore provided some insight on TAP's potential for distraction. As before, the use cases were not treated as independent variables in the experimental design but rather were included as mechanisms to trigger reroute decisions using TAP.

Dependent measures in HITL-2 were intended to be the same as HITL-1, except eye-tracking data collection errors in HITL-2 precluded analysis of timing and region-of-interest metrics. Subjective data collection included measures of perceived workload, usability, and SA. Post-simulation questionnaires were also issued to the pilots.

10.4.3. Results

The following high level results from HITL-2 are limited as a result of exclusion of the off-nominal event and issues with eye-tracking data collection. A complete description of the experiment design, methods, apparatus, analyses, and results are presented in reference [49].

The first analysis objective was to assess the updated TAP user interface (Figure 15, p63), including comparisons to the initial user interface (Figure 14, p60) where possible. An analysis comparing the subjective measurement of perceived pilot workload between HITL-1 (initial TAP user interface) and HITL-2 (updated TAP user interface) did not detect a significant difference in perceived pilot workload with the change in user interface design. The result confirms the HITL-1 finding that pilot workload is not adversely affected by the presence of TAP in the tested use cases, even with the significant design update to the user interface.

Subjective assessments of system usability and SA also showed no significant differences between the user interface designs. All subjective ratings for the updated TAP user interface were favorable: very low perceived workload, high system usability, and high SA. Pilot ratings of display elements indicated high ratings of comprehension, usability, and usefulness for nearly all features, with the exception of the ATC response buttons. These buttons enabled pilots to record whether ATC approved or denied a route modification request, a non-essential entry for operations and included only for data analysis purposes in the upcoming operational evaluations. These buttons would likely be removed in commercial versions of TAP.

The second analysis objective was to assess the impact of TAP on EFB multi-tasking. The first TAP flight had no additional special tasks beyond using TAP to address the use case events (TAP-only), whereas on the second TAP flight, special events were added to most use cases that required additional action by the pilot using other applications on the EFB (TAP+2ndApp). A comparison of subjective workload ratings between the TAP-only flight and the TAP+2ndApp flight indicated marginally higher pilot-perceived workload on the TAP+2ndApp flight. The finding is consistent with the second flight having extra tasking related to the special event.

Subjective ratings of TAP usability were not affected by EFB multi-tasking. Rather than switching back and forth, all pilots only switched to the second EFB application once, and then they switched back to TAP once they completed the tasks requiring the second EFB application. This indicates that the pilots prioritized the special events higher than using TAP, an appropriate response given that the special events were always higher criticality to the flight than route optimization. It also indicates that TAP did not distract the pilots from conducting these higher

Human Factors Assessment

criticality duties. Subjective ratings indicated a reduction in SA with the addition of the special events, a finding that is commensurate with the increased task complexity that was introduced with the special events, which were always presented without warning.

The third analysis objective was to assess the efficacy of the CBT as a standalone training tool for pilots. Comparisons were made between the two groups of pilots that received either instructor-led training or the CBT. The difference in subjective (i.e., perceived) workload between the training methods was not statistically significant. Observations by the confederate pilot and test director in the simulation cab during the simulation runs indicated that the CBT-trained pilots appeared to be more engaged with TAP and be more assured in TAP interactions than the instructor-trained pilots. TAP usability was rated higher by CBT-trained pilots, whereas there was no difference in SA ratings.

In summary, the updated TAP user interface was rated highly by pilots, indicating likely suitability for operational use, and it presented no workload increase over the initial user interface. TAP was not found to present any issue with EFB multi-tasking, and the special events requiring use of the EFB for non-TAP purposes always took precedence over TAP usage. The TAP CBT was effective as a standalone training method, potentially producing greater pilot engagement and perceived system usability. Both factors would likely lead to increased pilot use of TAP, which would be beneficial to the operator in terms of increased operational benefits from TASAR.

11. Flight Trials

More than any other activity, the two NASA TASAR flight trials in 2013 and 2015 effectively established the TASAR project on a trajectory toward achieving its goal of technology transfer to industry. Certainly, the flight trials played a necessary and crucial role in advancing TASAR to TRL 6 by transitioning the TAP software from the laboratory to a “relevant environment” onboard an aircraft operating in the NAS. Navigating this transition involved solving numerous engineering challenges and resulted in technology that was more mature and field-proven. Just as important, however, was the witnessing of this transition by airline decision-makers and key industry players. In retrospect, it is evident that some early decisions by the NASA team for the flight trials established connections to certain industry companies and leaders that would later play key roles in amplifying TASAR’s progression toward higher TRL and commercialization. In effect, the companies and people with the earliest exposure to TASAR were among those who would position themselves to bring it to market.

No market exists without a customer, however, and the flight trials were instrumental in securing interest by several prominent airlines in possibly acquiring TASAR technology for their fleets. Most airlines have tech pilots who, among other duties, evaluate emerging technologies and champion the integration of a few choice technologies into their fleets. Here, the flight trials intersected with the TASAR outreach strategy. The NASA team invited senior tech pilots from a cross-section of airlines to assist NASA in the flight trials as evaluation pilots. Not only would they help NASA mature its technology by providing their extensive expertise as senior airline pilots, they would have the opportunity to evaluate the technology for themselves, seeing it up close performing its actual function in an actual flight environment. From this convergence of interests, NASA emerged from the first flight trial with two partner airlines and the rare opportunity to take the technology forward into an operational evaluation in airline revenue service. Furthermore, interest had taken root with several other airlines participating in the NASA flight trials, and they would follow the partnerships and evaluations with interest and remain engaged with NASA and its partner airlines along the way. In other words, a market for TASAR in the airline community was beginning to form, spawned from the NASA TASAR flight trials.

The challenge of actually conducting a flight trial fewer than two years into the project should not be understated. As described earlier, TAP was derived from AOP, a research prototype software system that had only operated in a desktop simulation environment. While reconfiguring AOP into TAP, the software team also had to develop a software architecture capable of connecting to a live aircraft avionics data feed and adapt TAP to be compatible with the flight test aircraft, a Piaggio Avanti high-performance turboprop aircraft with unique avionics data characteristics and performance modeling. Meanwhile, the aircraft itself would need equipment installed and certified to provide the new “connected EFB” architecture for which TASAR was designed. The first section below describing FT-1 summarizes the work performed to create the first TASAR-capable aircraft and the objectives, design, and outcomes of the first TASAR flight trial that validated TAP’s usability in the real world. The second section describes the second flight trial, which leveraged essentially the same flight-test platform to prepare for the upcoming airline operational evaluations, reducing deployment risk for the partner airlines wherever possible. The third section briefly summarizes the plan for a third flight trial (FT-3) on weather data integration. FT-3 was initiated but not completed due to a change in programmatic funding and priorities.

Flight Trials

11.1. TASAR Flight Trial 1

The first TASAR flight trial was conducted in November 2013, 20 months after the February 2012 project kickoff. Complementing the FT-1 summary presented below are further details in references [50] and [51].

11.1.1. Objectives

The primary motivation for flight-testing TAP was to bridge the critical divide between TRL 4 (component testing in a laboratory environment) and TRL 6 (system testing in a relevant environment). As this would be the first airborne operational test of TAP, a conservative set of objectives was established to incrementally verify the TAP system of integrated software and hardware, building towards operational use of the tool. The four objectives of FT-1 were:

1. Verification of the TAP data interfaces
2. Verification of the TAP software functionality in flight
3. Assessment of TAP usability in an operational environment
4. Opportunity-based TAP route optimization requests to ATC

The first objective was to confirm that TAP successfully ingested and managed data from an operational (and potentially noisy) avionics data environment. Having been tested up to this point in a relatively pristine simulation environment, TAP needed a flight test to verify that the required data were received, that the data were sufficient for processing, that any real-time environment factors such as data drops and lags were properly handled, and that TAP could sustain operations under these conditions for the duration of a typical flight. It also provided a good opportunity to discover corner cases regarding any data parameters for which TAP may have been designed with incorrect assumptions.

The second objective was to confirm that TAP performed its various functions in flight as it did in simulation. This primarily involved exercising all of the functions while attempting to “break” the system with heavy use. However, purposefully not included in FT-1 was validation of time and fuel savings estimates from TAP route optimization solutions, other than identifying clearly-incorrect estimates. A methodology to validate savings was later developed and tested in FT-2.

The third objective complemented HITL-1 by evaluating TAP usability from a pilot’s perspective. The flight environment introduced variables not easily replicated in the university’s fixed-based flight simulator, such as ambient lighting changes, turbulence, and the operational tempo of actual flight. As mentioned earlier, FT-1 also provided an opportunity to introduce TASAR to airline decision-makers and create the context for follow-on exploratory partnership-building discussions.

The fourth objective was to make actual route modification requests to ATC based on TAP advisories, where opportunities presented themselves. This objective was treated as lower priority than the other three, since any approved requests would have the effect of removing route inefficiencies needed to support the first three objectives. Once these objectives were met on a given flight, the evaluation pilots were given the opportunity to select a TAP solution for request to ATC and execution, if approved.

Flight Trials

11.1.2. Apparatus

A Piaggio P180 Avanti, operated by Advanced Aerospace Solutions, served as the test aircraft for the flight trial. The aircraft is shown in Figure 17. As described in reference [51] four characteristics of this test platform directly supported the objective to accelerate the operational readiness of TAP: the aircraft retained its Normal Category airworthiness category, it was certified for single-pilot operations, it had a large cabin, and it had a broad flight envelope. Retention of a Normal Category Certificate of Airworthiness streamlined the reuse of the TAP software for subsequent deployments of the system and provided further evidence to early adopters



Figure 17. Piaggio Avanti flight-test aircraft used in FT-1 and FT-2. Photo by author.

of TAP suitability for commercial use. The single-pilot certification eliminated restrictions regarding the occupancy of the copilot's seat, thereby providing cockpit seating for the evaluation pilot, and it also enabled the use of uncertified software on the non-handling side of the cockpit. The Avanti's large cabin accommodated a seven-person test-crew comprising a safety pilot, an evaluation pilot, the test director, a flight test engineer, a data engineer, a TAP software engineer, and a NASA researcher. A broad flight envelope was deemed essential to achieving the objective of hosting TAP in a representative operational environment. The Avanti was certified for all-weather single-pilot operations. It had a cruise speed of approximately 375 knots (0.65M) at 28,000 ft and a ceiling of 41,000 ft. The aircraft was fuel-efficient, allowing for longer test missions, and the cabin was large enough to accommodate the full test crew with their laptops and recording equipment.

Four hardware adaptations were made to the Avanti to support the TASAR flight trials. The first was installation of a certified AID. As TAP must interface to a number of aircraft data sources, which could vary widely from aircraft to aircraft, a decision was made to standardize all TAP-to-aircraft interfaces through an AID that embodied all of the required data connectivity. A compact United Technologies Corporation Aerospace Systems (UTAS, formerly Goodrich, later Collins Aerospace) AID was chosen, which incorporated multiple ARINC 429 input channels and packaged the 429 data in ARINC 834 format for TAP consumption. (A later generation UTAS AID would eventually be chosen by Alaska Airlines for the TASAR operational evaluation.) Use of industry-standard protocols mitigated technical risk for future TAP installations because the TAP software remains agnostic to the aircraft interfaces upstream of the AID.

The second adaptation was the integration of the Goodrich/UTAS SmartDisplay G500 Class 2 EFB. For risk mitigation purposes, a requirement for the chosen system was for it to support a certified operating system, should it eventually be required in future testing. No such requirement emerged. The EFB was selected to meet the physical size and processor performance expectations of EFBs thought likely to be used by the prospective operator community. In FT-1, the TAP application was hosted locally on the SmartDisplay which communicated with all of the pertinent aircraft data systems via the AID. The evaluation pilot's EFB was mounted on the copilot's right-

Flight Trials

side windshield using dual suction cups, as shown in Figure 18. Additional instances of TAP were hosted on a second SmartDisplay EFB and two engineering laptops available to crewmembers in the aft cabin, for independent TAP evaluations and debugging purposes.



Figure 18. EFB installation in the Avanti Cockpit. Photo by Advanced Aerospace Solutions.

The third adaptation was to install a certified Inmarsat broadband link to enable TAP to access internet data sources for in-flight data updates. For FT-1, the internet link was used specifically to connect to NOAA web services to receive hourly wind-field updates. Internet connectivity was later used in FT-2 to also receive SUA schedule and weather polygon data, whereas in FT-1, SUAs were considered always “hot” and weather polygons were not tested. The internet system bandwidth was limited to 200 kbps, due to size constraints of the installed low-profile, low-gain blade antenna. Though a higher bandwidth system would have enabled more efficient flight testing, it provided a good test condition to establish performance acceptability in low-bandwidth installations. The Inmarsat hardware also provided a full-service router for the aircraft, allowing several TAP instances to share the internet data received by a single EDS.

The fourth adaptation was to install an updated Traffic Alert and Collision Avoidance System (TCAS) capable of ADS-B In, a data source central to the TASAR concept of traffic-aware route optimization. To ensure the transferability of the TAP installation to future operational platforms, the field-proven Aviation Communication & Surveillance Systems (ACSS) TCAS 3000SP ADS-B In/Out capable TCAS was installed. For the Avanti, ACSS created a software patch enabling the ADS-B In system to output DTIF traffic data, normally triggered by the presence of a CDTI (not installed). Coincidentally, Alaska Airlines aircraft were equipped with the ACSS TCAS 3000 SP. ACSS would later upgrade and certify the Alaska Airlines units to ADS-B In for the TASAR operational evaluation.

The TAP software tested in FT-1 was TAP v3, functionally equivalent to TAP v2 tested in HITL-1 but included an updated user interface with some usability enhancements, for instance, improvements in touchable areas and buttons for better visibility and labeling. Several data status screens were also added for use only by TAP software engineers, not evaluation pilots. The updated user interface tested in FT-1 is shown in Figure 19. Note that this interface design, tested in November 2013, preceded the TAP v14-1 design of HITL-2, shown in Figure 15 (p63) and tested in October/November 2014.

11.1.3. Method

A 10-flight 30-hour flight-evaluation campaign was planned including four hours of shakedown testing and 26 hours of dedicated TAP evaluations. Nine test flights were successfully completed, with one flight aborted due to a non-TAP aircraft equipment malfunction. The trials were conducted on IFR flights in the NAS along the U.S. eastern seaboard, with all flights originating and terminating at the Newport News / Williamsburg International Airport (KPHF). Several “round-robin” routes (i.e., out and back without an intermediate landing) were designed, based on

Flight Trials

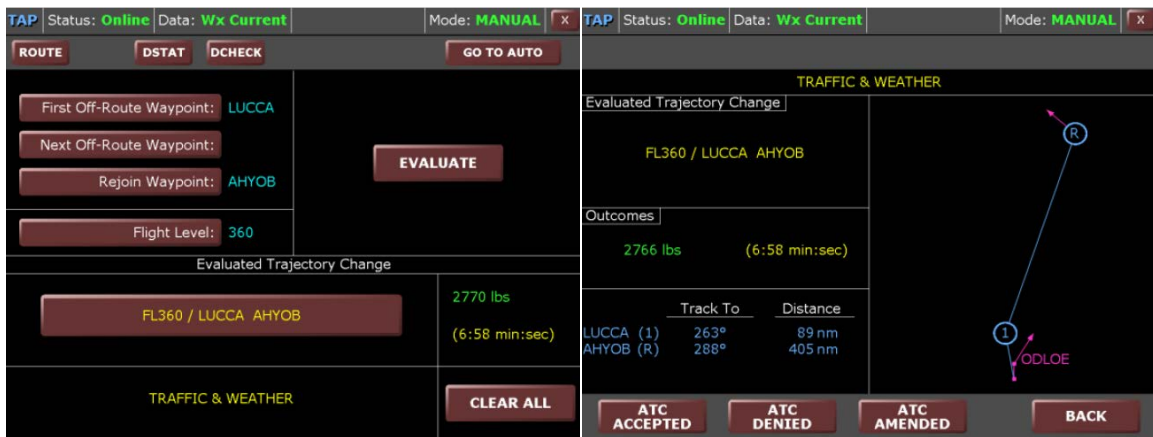
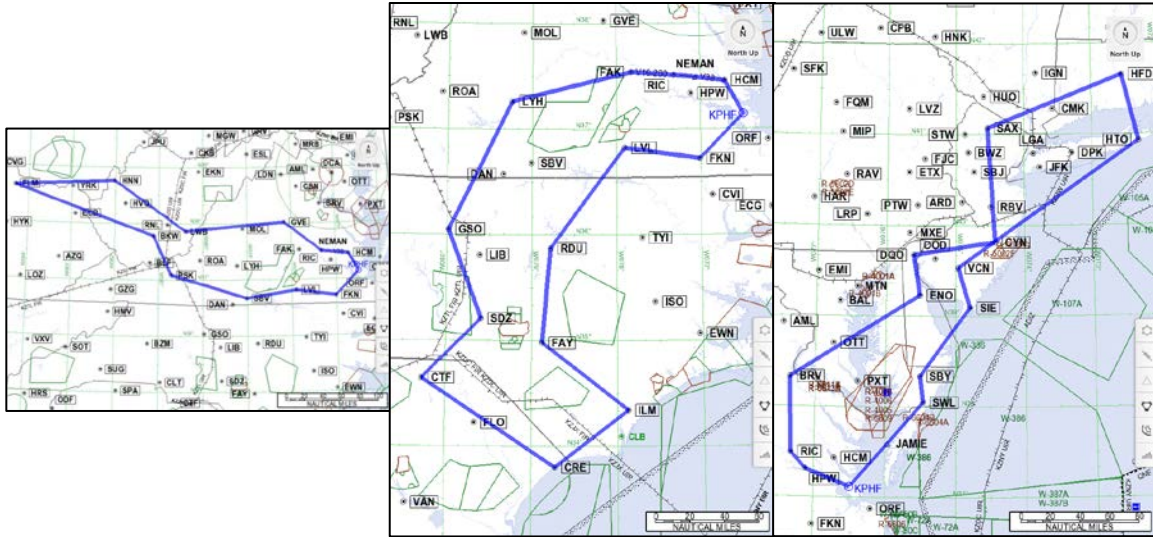

Figure 19. TAP v3 user interface tested in FT-1.

published high-altitude IFR navigation aids and fixes. Four flight profiles were selected to exercise TAP’s route optimization functionality in the presence of potential SUA and traffic conflicts (see Figure 20). By varying the geographic regions and altitudes of the flight profiles, TAP exposure to complex airspace factors (i.e., traffic densities and SUAs) could be approximately managed. The intention was to start at low complexity with Route 1 (low traffic density with no SUAs) and gradually increase complexity to Route 6 (high traffic density with SUAs). Table 11 shows the test matrix of FT-1 as flown. The routes were coordinated each day with ATC traffic managers, and at their request, the final three flights planned for Route 6 were flown as Route 5 due to high ATC workload.

The flight crew consisted of a safety pilot (pilot-in-command) and an evaluation pilot. Nine senior IFR-rated evaluation pilots were employed in the study, consisting of six senior airline captains, one senior first officer, and two highly experienced aviators. The operator communities represented were major, regional, and low-cost airlines, and high-end General Aviation. An evaluation pilot on the internal NASA TASAR team conducted the end-to-end systems checkouts and procedure rehearsals on flight 1, and the remaining flights were performed with the eight external evaluation pilots. The evaluation pilots received approximately two hours of dedicated TAP training on the day of their flight. During the flight, they performed structured TAP evaluation

Flight Trials



(a) Route 1 west of KPHF, high altitude.

(b) Center: Route 3 south of KPHF, low altitude.

(c) Right: Routes 5 and 6 northeast of KPHF, high altitude and low altitude, respectively.

Figure 20. FT-1 round robin routes from KPHF. From ref. [51].

procedures established for the outbound and inbound legs of the round-robin flight, while also completing multiple in-flight questionnaires and workload surveys. Each evaluation pilot was thoroughly debriefed post-flight.

The safety pilot played no role in the evaluation pilot’s use of TAP, except for providing assistance in the configuration of the aircraft’s displays and interacting with the FMS as requested. The safety pilot performed all normal aircraft operations during the outbound legs of each flight, but assigned radio communications duties to the evaluation pilot during the inbound legs to provide representative PM workload for this phase. The cabin crew typically comprised five personnel: a

Table 11. FT-1 test matrix. From ref. [51].

Flight #	Route #	Direction	Initial Flight Level (FL)	Traffic Density	SUA Proximity
1	1	CCW ^a	FL300	Low	No
2	Flight aborted	-	-	-	-
3	3	CCW	16,000 ft.	Low	Yes
4	3	CW ^b	16,000 ft.	Low	Yes
5	5	CCW	FL340	High	No
6	5	CW	FL340	High	No
7	6	CCW	FL210	High	Yes
8	5 ^c	CW	FL310	High	No
9	5 ^{c,d}	CCW	FL310	High	No
10	5 ^{c,d}	CW	FL310	High	No

^aCounterclockwise. ^bClockwise. ^cOriginally planned as Route 6.

^dIncluded minor revision to route to eliminate route overlap.

Flight Trials

test director, a flight test engineer, one or two TAP software engineers, and one or two NASA researchers. The test director orchestrated and performed all aspects of evaluation-pilot data collection during the flights. The aircraft flight test engineer managed the aircraft's data systems and TAP interfaces. The TAP software engineers exercised TAP independently from the evaluation pilot and performed any necessary real-time troubleshooting. The NASA researchers also operated independent instances of TAP for real-time monitoring and testing.

11.1.4. Results

A summary of FT-1 results is presented in four sections, corresponding to the four flight trial objectives: (1) TAP Data Interface Verification; (2) TAP Functionality Verification; (3) Pilot Subjective Evaluation; and (4) TAP Operational Use. See references [50] and [51] for detailed results.

TAP Data Interface Verification

As FT-1 was the first opportunity to adapt TAP to the avionics environment of an actual aircraft, the initial phases of TAP integration posed a number of challenges related to the aircraft-side data sources. Chief among these was the GAMA subset of ARINC 429 data output by the Avanti FMS, which differed from the enhanced 429 structure used in the NASA simulation of transport category aircraft. GAMA data are usually used for the display of route and waypoint symbology on flight displays. To meet TAP data requirements, these data had to be supplemented by other sources, such as the Flight Data Recorder bus.

The flight-trial version of the TAP software was developed in iteration with the aircraft integration activity. Three data-related problems hampered the pre-test integration efforts on the ground. TAP required the aircraft to provide valid in-flight air data in order to function, which entailed the use of an unwieldy Air Data Computer test set for all ground tests to simulate an in-flight condition. Similarly, a complex procedure was required to force the Inertial Navigation Systems into a simulation mode that would allow the aircraft to generate usable groundspeed data for TAP. In addition, limited satellite signal reception in the airport environment compromised EDS connectivity during ground testing. Due to these issues, the integration logistics were more challenging than originally anticipated. Advantage was taken of additional data collection tools in the TAP software, FMS, and aircraft computer servers that enabled the unattended collection of TAP data while the aircraft was engaged in flights unrelated to TAP. These data could then be fed through a playback capability of the TAP software to conduct integration testing. Almost 40 hours of these in-flight opportunity data were collected, reducing the dedicated TAP-integration flight time requirement to 3.2 hours. After the troubleshooting was completed, a successful end-to-end system test was performed immediately prior to the shakedown flight. The TAP data interfaces functioned satisfactorily thereafter, allowing TAP to perform as designed and EDS to successfully download the updated wind data. Nevertheless, a number of data problems persisted during the flight trials, including data dropouts, latency, and vertical speed noise. These artifacts are inherent to a live avionics and ADS-B environment, though some were artifacts of the flight testing.

Maximizing the FT-1 testing opportunity, up to five instances of TAP were operated simultaneously on each flight, each connecting to the AID's ARINC 834 server. As the AID was designed to serve only two clients (a pilot EFB and a copilot EFB), the server occasionally became overloaded, resulting in data dropouts and latency. Though this would not generally manifest in an operational environment with only the two AID clients, the finding did uncover a potential

Flight Trials

weakness. The limiting case was found to be the transfer of a full flight route, which required multiple messages from the FMS to fully define the route. This was the only data label with inter-arrival times that frequently exceeded TAP's processing frame of one second. It highlighted the potential for dropouts to coincide with flight route changes that could result in TAP optimizing against an out-of-date flight route.

Examination of vertical speed data for both the ownship and ADS-B traffic indicated vertical speed variations of up to ± 4000 feet per minute, which was particularly noticeable during periods of turbulence. TAP does not use vertical speed for ownship predictions, but there was a concern about the stability of traffic ADS-B vertical speed values and the impact they may have on traffic trajectory prediction. Vertical speed is used by TAP to predict the vertical component of the ADS-B traffic trajectory since the target altitude is not part of the ADS-B message set received by TAP. In a simulation environment, the vertical speed value is generally stable and accurate. In flight, turbulence may result in brief accelerations that, in turn, can result in temporarily large vertical speed being broadcast. The vertical speed noise could potentially cause TAP to generate advisories that are traffic-incompatible and/or less beneficial, if not otherwise mitigated. No significant outliers or noise was observed for any other ARINC data labels across the nine flights.

TAP Functionality Verification

In nearly all cases, TAP passed the initialization-sequence connection tests, entered the online mode at 10,000 ft as designed, and generally operated correctly and stably throughout the flight. Two aspects of the software caused occasional problems during the trials: the aircraft performance model and the ADS-B vertical speed fluctuations discussed above. TAP trajectory generation and optimizations rely on an accurate digital aircraft performance model, which was unavailable for the Avanti test-bed aircraft. Development of such digital models from aircraft performance handbooks is time-consuming and expensive, and the magnitude of the task was underestimated. As a compromise, a performance model of a generic twin-engine, medium-sized jet was scaled to approximate the en-route performance of the Avanti (a high-performance turboprop). This approximation impacted TAP's predictive capability and curtailed all route optimization computations while the aircraft was climbing or descending. Use of this model also introduced errors in the fuel and time calculations that made precise quantification of the optimizations difficult. An accurate Avanti model was developed for FT-2 as was a new trajectory generator that is more flexible to variations in available performance data [44].

Pilot Subjective Evaluation

Generally, the evaluation pilots rated usability of TAP as high, and their perceived workload was low, which is consistent with the findings in HITL-1. Nearly all workload ratings were below 3 on the 10-point Bedford scale, indicating that workload was tolerable for the task, and they had enough spare mental capacity for all desirable additional tasks during flight operations. In the post-flight questionnaire and debrief, they reported that operating the TAP software application was relatively easy, with average scores above 5 on the 7-point Likert scale.

The evaluation pilots were asked to select from a list of 28 items those they considered to be the main benefits of TASAR and the TAP application. No limit was placed on the quantity they could select. Benefits directly related to the flight itself, including fuel and time savings, optimal routing, and airspace hazard avoidance, were most prevalent in their selections. TASAR was also viewed by most evaluation pilots as providing equipage justification for ADS-B In, EFB, and cockpit internet access. Completing the set was the reduction in workload for pilots in assessing route-

Flight Trials

change impacts and the reduction in workload for air traffic controllers in flight optimization. Not selected by the majority were workload reductions for pilots and controllers in other areas (e.g., communication, coordination, maintaining SA). Interestingly, no evaluation pilot identified dispatcher workload reduction in post-departure flight optimization as a main benefit of TASAR. When taken together with the prevalent selection of optimal routing as a TASAR benefit, it may indicate a pilot perception that dispatchers do not often perform post-departure flight optimization. If true, TASAR may be well-positioned to fill this gap in current operations.

The evaluation pilots emphasized the importance of consistency in TAP's advisories, both between Auto Mode and Manual Mode, and over time. These comments were elicited when TAP presented fluctuating optimizations over relatively short timespans. Based on detailed post-flight analysis, these fluctuations were generally valid outcomes resulting from changing trajectory dynamics or new intruder traffic, making optimal routes temporarily unavailable. Nevertheless, the evaluation pilots were clearly more comfortable when TAP settled on a single solution for an extended period. This led to a software design update where TAP's genetic algorithm would include the previous solution in the competitive search for the next solution, resulting in more stability unless clearly superior solutions emerged or the previous solution was no longer conflict-free. Evaluation pilots also desired a more detailed depiction of the current route on the TAP user interface and greater use of the EFB's touch-screen interface (e.g., for entering waypoints), both of which were incorporated into the significant design update of the TAP user interface (Figure 15, p63) tested subsequently in HITL-2 and FT-2.

TAP Operational Use

TAP processed 710 unique ADS-B targets (i.e., traffic aircraft) during 19.5 hours of data collection (which excluded the departure and arrival flight phases). Analysis of ground-recorded traffic data indicates this was approximately 12 percent of the total traffic (non-ADS-B and ADS-B) within ADS-B detection range. About 85 percent of ADS-B traffic was first detected between 50 and 100 NM of the ownship. TAP's "traffic aware" functionality was already producing results on Flight 1, during which TAP indicated a traffic conflict on a proposed route modification entered in Manual Mode.

Figure 21 illustrates a route optimization from Flight 3 in relation to the original route and the SUA areas to be avoided. The red polygons represent the Seymour Johnson Echo Military Operations Area (SEY JON MOA) SUA. The green route indicates the original flight plan, and the yellow route indicates the "as flown" trajectory, flown counter-clockwise. Approximately halfway between waypoints ILM (far right) and FAY (bottom), the evaluation pilot consulted TAP for an optimization solution and made a route modification request to ATC, receiving approval shortly before reaching FAY. The solution and ATC clearance consisted of direct LANHO (waypoint chosen by TAP from its

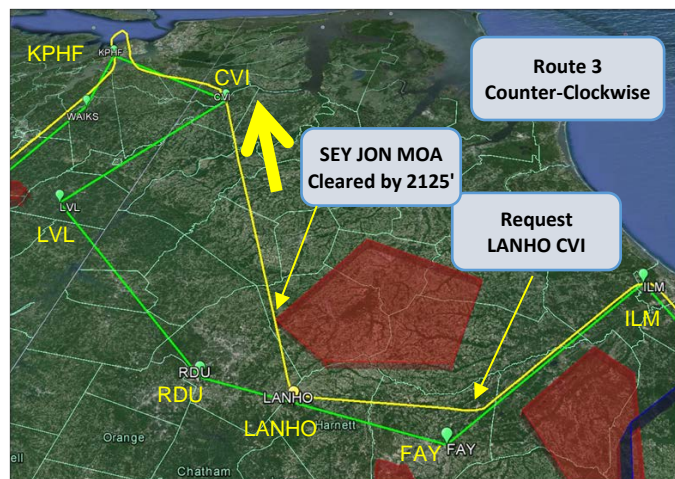

Green route is the planned route. Yellow route is as flown.

Figure 21. FT-1 SUA avoidance example. Base image from Google Earth™.

Flight Trials

waypoint database), direct CVI (the “rejoin” waypoint), bypassing FAY, RDU, and LVL from the original route. This solution passed just barely north of SEY JON MOA, illustrating TAP’s function to optimize the route while avoiding restricted airspace. However on a different flight in different airspace, a similar request resulted in ATC issuing a modification that provided additional separation from the SUA airspace, indicating a potential need for additional buffering in some situations. TAP was subsequently modified to include an SUA buffer (but which was later removed during the airline operational evaluation due to several “false positive” interactions of the active route with SUAs that resulted in acceptability concerns by pilots; further study of SUA buffering is therefore needed).

In total, 12 TAP-inspired ATC requests were made: two were denied, nine were approved, and ATC was unable to directly respond to the request in one case due to workload and/or frequency congestion. Some factors unique to the test design may have affected the ATC responses. These included the unusual round-robin nature of the flight paths, and the special treatment of the test aircraft by ATC.

The most significant outcomes of FT-1 were substantial increases in TAP maturity and visibility. With credit to the high-performing TASAR team, FT-1 uncovered and, in short order, verified solutions for numerous integration, functionality, and performance issues inherent to an actual flight environment. Notwithstanding these considerable challenges, FT-1 validated TAP as an effective and powerful route optimization tool for pilots, making a substantial, positive, and lasting impression on the evaluation pilots from a cross-section of airlines and operator communities. FT-1 triggered immediate partnership-building meetings, ultimately resulting in two SAAs to conduct formal operational evaluations in airline revenue service. This long-shot but welcomed advancement toward the TASAR vision had three effects. It triggered a significant reset of internal expectations and plans for the TASAR project’s reach, which now would extend to TRL 7 (system prototype demonstration in an operational environment). Press coverage of the airline partnerships triggered attention from industry on the commercial potential of TASAR. The high stakes resulted in a second HITL and flight trial to enhance readiness, reduce risk, and maximize success of the upcoming airline/industry operational evaluations of TASAR.

11.2. TASAR Flight Trial 2

FT-1 was essentially a generic flight trial of TASAR, validating whether TAP could be integrated into *an* aircraft and be used in *an* operational flight environment. However, the new airline partnerships to test TAP in *their* aircraft and *their* operational environment quickly brought focus to the question of how best to reduce risk and achieve the best chance for the airlines to successfully use and evaluate TAP on revenue flights. A second flight trial, FT-2, emerged as a means to increase operational readiness by anticipating and addressing integration and operational issues with the target airline environment in mind. Given these two airlines have very different platforms (i.e., airframes and avionics) and to remain within budget, FT-2 focused its technical integration where necessary on the Alaska Airlines implementation, which was to be the first of the two airlines to reach implementation readiness. However both airlines participated in FT-2, and the outcomes of FT-2 were geared to benefit both airlines wherever possible.

Seven technical objectives were identified for FT-2, all targeting the overarching goal of increasing operational readiness for the airline evaluations:

Flight Trials

1. Verify to the degree possible the extent to which TAP operates with partner airline hardware
2. Verify processing of additional external data intended for the airline evaluations
3. Assess the methodology to characterize the accuracy of TAP computed outcomes
4. Assess acceptability of TASAR requests to air traffic controllers
5. Assess acceptability of TAP route modification advisories to airline pilots
6. Assess in-flight usability and acceptability of the updated TAP user interface
7. Assess effect of TAP on flight crews and Crew Resource Management (CRM)

FT-2 took place over a two-week period in June 2015, using the Piaggio Avanti aircraft in the same configuration as FT-1 but with EFB hardware updated to approximate the anticipated Alaska Airlines environment. Three types of flights were conducted:

- Charter Flights: data were collected during charter operations on a non-interference basis for the purpose of systems checkout prior to formal data collection for the seven objectives;
- Evaluation Flights: data for Objectives 1–6 were collected during round-trip flights, staged from KPHF, with evaluation pilots; and
- Positioning Flights: data were collected for Objective 7 while positioning the test aircraft between its home base in Montreal and KPHF with a fully qualified Avanti aircraft crew.

The FT-2 evaluation flights were designed as a pair of origin-destination flights to be more representative of airline operations than the round-robin flights of FT-1. Six pairs of evaluation flights were conducted, one pair per day with a non-flying day in between. In each pair, the outbound flight departed KPHF and flew approximately 2.5 hours to one of three destination airports and landed. After a short break, the inbound flight departed that destination airport and returned to KPHF taking approximately 2.5 hours. The destination airports were:

1. Birmingham-Shuttlesworth International Airport (KBHM), Alabama
2. Montgomery Regional Airport (KMGH), Alabama
3. Tampa International Airport (KTPA), Florida

The conduct of each flight called for two evaluation pilots to fly per day. On the outbound leg, one evaluation pilot flew in the cockpit performing PM duties. The other pilot flew in the cabin. On the inbound flight, the pilots reversed roles. Both pilots on both legs had a functional instance of TAP to use in the evaluation. The first evaluation flight day served as a rehearsal, with two TASAR team pilots performing as evaluation pilots. The five remaining evaluation flights included evaluation pilots from Alaska Airlines, Virgin America, and a variety of other airlines. Each pilot was trained using the TAP CBT in anticipation of the partner airlines training their own crews using the same method. The TAP CBT was verified as an effective training tool in HITL-2.

Representative routes flown between KPHF and the three destination airports are shown in Figure 22. The KBHM and KMGH routes were designed to interact with traffic in the vicinity of Atlanta (KATL), whereas the KTPA routes were proximate to multiple SUAs while interacting with significant coastal traffic flows. The flights traversed Washington, Atlanta, and Jacksonville

Flight Trials

Air Route Traffic Control Centers, with most of the en route segments occurring in Atlanta (ZTL) and Jacksonville (ZJX) Centers. TASAR researchers monitored the flights from the ATC control rooms at ZTL and ZJX as part of accomplishing Objective 4, assessing ATC acceptability of TASAR requests. The requests were generally scripted to test acceptability of various factors involving route changes (e.g., a route change that clips an ATC sector), as TAP algorithms were not guaranteed to produce the desired factors. This scripted approach better permitted the on-site researchers to interview the air traffic controllers about these factors. The researchers working with traffic managers prioritized the requests for each flight depending on conditions of the day (e.g., weather, playbook routing, traffic flow restrictions). They coordinated the desired requests with the flight team prior to each flight.

The following sections summarize the purpose, method, and findings of each FT-2 objective. Further details can be found in references [52] and [53].

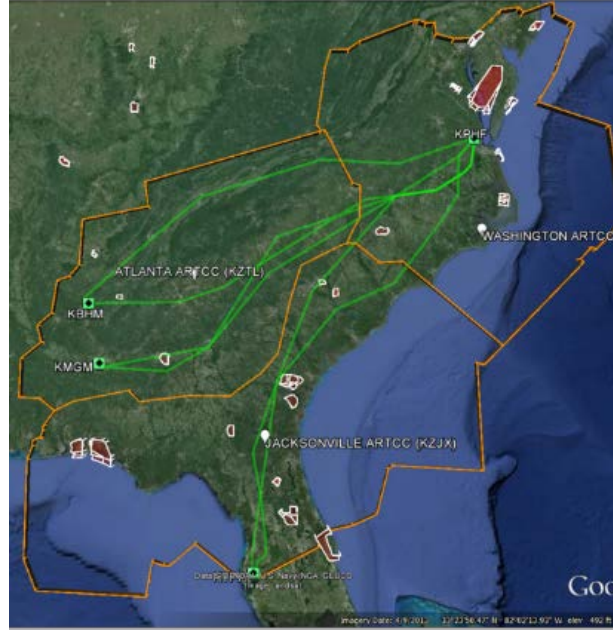

Washington, Atlanta, and Jacksonville Air Route Traffic Control Centers are shown in orange.

Figure 22. FT-2 representative routes. Base image from Google Earth™.

11.2.1. Objective 1: Verify that TAP operates with partner airline hardware

The purpose of Objective 1 was to identify potential issues that may prevent TAP from operating properly on the EFB and associated hardware of the upcoming airline operational evaluation. The FT-2 approach was to test TAP in a configuration as close as possible to the hardware and data configurations anticipated to be used by Alaska Airlines. Since the Alaska Airlines configuration was not finalized by the time of FT-2 planning, assumptions were made where necessary. Diagrams of the respective EFB system architectures on the Alaska Airlines and Piaggio Avanti aircraft, shown in Figure 23, illustrate the planned similarities and some of the necessary differences.

Both configurations incorporated the same iPad Air, UTAS Tablet Interface Module (TIM), and UTAS AID hardware, though only the iPad was able to host TAP software in both configurations. The TAP software development to enable Universal Serial Bus (USB) data connectivity through the TIM was not available for FT-2, nor were the Gogo processor and the AID hardware version capable of hosting third-party software applications. TAP was also not yet configured to run in a Linux environment, and therefore separate Windows™ processors on the Piaggio Avanti were used to host the remaining TAP software components. The ADS-B receiver used for FT-2 was the same receiver expected to be used by Alaska Airlines (ACSS TCAS 3000SP). Other differences, previously discussed for FT-1, were avionics data streams with unique formats and data rates due to differences in each aircraft's FMS hardware. Compared to FT-1 where up to five TAP instances were connected to the ARINC 834 server (causing AID performance issues), only three TAP instances were connected in FT-2: two for the evaluation pilots and one shared by NASA

Flight Trials

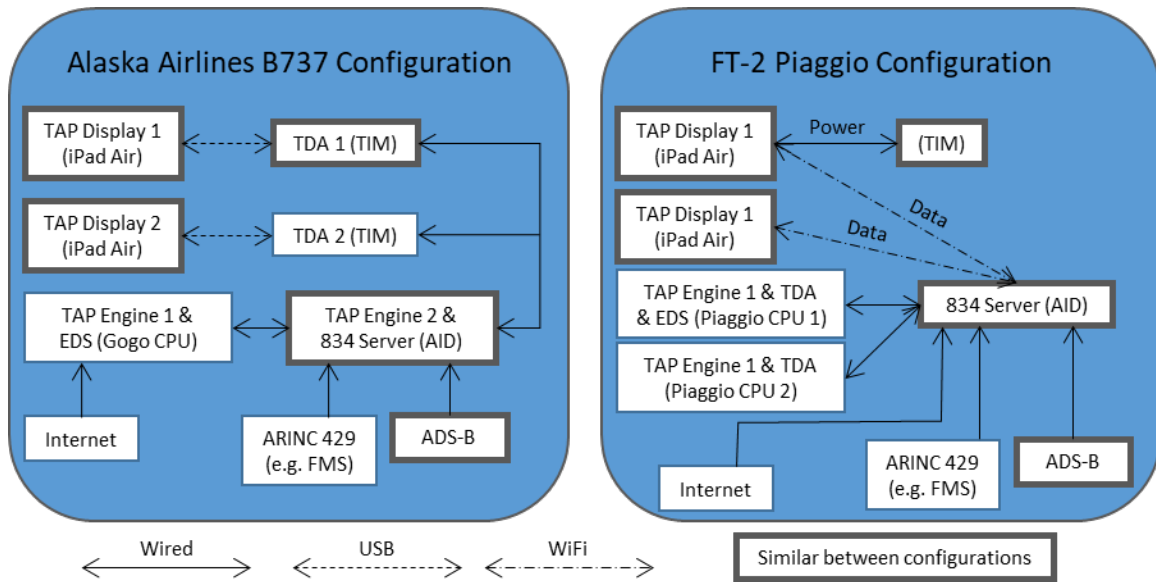

Figure 23. Architecture comparison of Alaska Airlines and FT-2 test configurations.

researchers and TAP engineers. Still, this represented a conservatively higher load placed on the AID than would be expected during Alaska Airlines operations.

Data collection for this objective required no actions by personnel onboard other than starting TAP and transferring the recorded files post-flight. TAP and EDS automatically recorded all data required to complete Objective 1 post-flight analyses. Metrics were calculated to quantify data dropouts, data noise and outliers, ADS-B characteristics, TAP inter-process communications, and TAP performance.

Data Dropouts

Analysis of data inter-arrival times indicated that large data dropouts were rare in the Piaggio Avanti configuration. Only one large dropout of 55 seconds was recorded, occurring on a flight when TAP was initiating a subscription to the AID. This confirmed FT-1 findings that showed a higher likelihood of dropouts when the AID is experiencing higher loads. All other dropouts across the entire FT-2 dataset were small, with none exceeding three seconds. Inter-arrival times between date/time messages exceeded 1 second 47 percent of the time but exceeded 1.25 seconds only 0.1 percent of the time, an impact that was determined to be negligible.

Data Noise and Outliers

Analysis of decoded-data value changes over time confirmed that no data outliers or unusual noise were present, with the exception of altitude rate (i.e., vertical speed), which is consistent with FT-1 results. The largest change in ownship altitude rate was correlated with in-flight turbulence. TAP has additional ownship intent information regarding target altitude that mitigates altitude rate noise. However, such intent information is not available for traffic aircraft through the ADS-B DTIF data. An analysis of a candidate ADS-B altitude rate filter was performed to determine whether the filter would sufficiently reduce data noise. The analysis, presented in reference [52], concluded that applying an altitude rate filter would not significantly improve the altitude component of ADS-B traffic trajectory predictions due to lack of intent information. While filters may decrease noise, they also decrease the probability of detecting a traffic aircraft departing

Flight Trials

level flight from its current altitude or leveling off from a climb or descent. Before implementing such a method it is suggested to explore internet-based sources of traffic intent information such as SWIM.

ADS-B Characteristics

Analysis of ADS-B data showed that more aircraft were detected by the ownship during FT-2 (216 unique aircraft detected per flight) than FT-1 (79 unique aircraft detected per flight). This could be due to FT-2 being conducted in more traffic-dense airspace primarily near Atlanta and/or more aircraft being equipped with ADS-B in the 19 months since FT-1. ADS-B traffic aircraft were generally first detected at a farther distance from the ownship during FT-2 than FT-1. The reasons for this difference could be different characteristics of installed ADS-B Out systems and different interference characteristics experienced during FT-2 as compared to FT-1. There was no significant change to the ownship ADS-B system's reported quality of ADS-B messages received during FT-2 (98.6 percent of messages valid) compared to FT-1 (98.9 percent of messages valid). TAP discards all invalid ADS-B messages to prevent using unreliable data.

An analysis was also performed to determine the effect of ADS-B traffic data on TAP's route optimization solutions. TAP data files recorded on one of the TAP instances running onboard were replayed post-flight with ADS-B data removed. For this instance of TAP, there were a total of 939 TAP Engine optimization runs during FT-2 which were re-run without ADS-B traffic. Of the 939 invocations, 186 (19.8 percent) had different results after removing the ADS-B traffic. In 50 cases (5.3 percent) TAP found a solution without ADS-B traffic but could not find a solution with ADS-B traffic. The remaining 136 cases (14.5 percent) consisted of TAP finding different solutions with and without ADS-B traffic. TAP route modification requests that do not take nearby traffic into account are considered less likely to be approved by ATC, thereby reducing potential benefits and pilot acceptability of TAP.

TAP Inter-process Communications

Reliable messaging between TAP Display and TAP Engine is important for the stability and health of the software. The TDA was added to the TAP software architecture to support periods where the iPad may be sleeping or running a different app. An analysis of messages from the TAP Engine to the TAP Display (via the TDA) indicated all messages were received except those sent when the iPad was either sleeping or turned off. Messages in the opposite direction were all received except for when the TDA was shut down before the TAP Display. This finding resulted in the Alaska Airlines architecture design that gave the TAP Display the role of managing launch and shutdown of all other TAP components.

An analysis of inter-process data latency indicated transitory latencies of up to eight seconds. These latencies started after the iPad had to re-synchronize due to, for example, initial start-up or entering sleep mode and lasted up to about fifteen seconds after re-sync (i.e., there were multiple messages that experienced latencies and the last one occurred about fifteen seconds after re-sync). After this transitory condition passed, 99.7 percent of messages arrived with a latency of less than 0.2 seconds. However, this latency may also be due to hardware performance issues since it was observed that these high latencies occurred near the times of wind update synchronizations that contained a lot of data. This condition could serve as a hardware performance test case whereby large amounts of data are sent from the TAP Engine to the TAP Display to assess whether sending large amounts of data is causing problems. This issue was later seen in the Alaska Airlines operational evaluation.

Flight Trials

TAP Performance

TAP performance is characterized by skipped processing frames (due to in-cycle processing taking longer than the 1-second processing frame duration), TAP PBGA completion time (i.e., computation of route optimizations), and hazards processing time. Other than one instance of 345 consecutively skipped frames due to a TAP software error, only 51 skipped frames were recorded throughout all of FT-2, occurring randomly. This indicated that hardware CPU performance did not negatively degrade TAP during FT-2.

The TAP PBGA was invoked 1,958 total times during FT-2 across all TAP Engines. The maximum, mean, and standard deviation of the time to complete PBGA processing was 38 seconds, 5.7 seconds, and 4.4 seconds, respectively. These statistics confirmed that hardware CPU performance did not negatively degrade TAP during FT-2.

Hazards processing time is the time to create trajectories for ADS-B target aircraft and avoidance polygons for SUAs and convective weather. The maximum TAP hazards processing time during FT-2 was 0.05 seconds, indicating that hazards processing time was not a factor during FT-2. One reason for the low hazards processing time is that there were few convective weather hazard polygons used by TAP in FT-2. The maximum convective weather, SUA, and ADS-B traffic hazards processed at one time during FT-2 was 12, 564, and 35, respectively. It was expected that TAP on partner airline aircraft will interact with more convective weather hazard polygons than were experienced during FT-2.

11.2.2. Objective 2: Verify processing of additional external data

The purpose of Objective 2 was to evaluate the performance of TAP in obtaining external data using an airborne internet connection and transferring the data locally to the TAP Engine. The internet system on the Piaggio Avanti was different than the internet systems on Alaska Airlines and Virgin America aircraft. Therefore, the focus was to evaluate TAP's EDS capabilities using the Piaggio Avanti internet system as a conservative proxy to the assumed aircraft internet systems. The Piaggio Avanti internet system was a conservative proxy because it is a satellite system (200 kbps) that has approximately 1/15th the bandwidth of the Gogo cell tower-based system (3 Mbps) used by Alaska Airlines.

Three types of data were obtained in FT-2:

1. Gridded winds and temperature aloft from the NOAA Rapid Refresh (RAP) weather prediction model
2. SUA activation schedule from FAA SUA public website
3. Convective Significant Meteorological Information (SIGMET) polygons from Weather Services International (WSI, later The Weather Company, an IBM Business)

There are three stages to TAP's process of incorporating external data from the internet. The first stage is EDS downloading the data via the internet. During FT-2, the onboard EDS had a complementary Ground Data Server (GDS) that downloaded weather data from WSI, Alaska Airlines' approved weather data provider. This initial version of GDS only processed WSI Convective SIGMET polygons and filtered out all other WSI data not relevant to TAP. The second stage is EDS performing a format conversion. During FT-2, EDS converted WSI and public data to TAP's internal format without any preprocessing by GDS. The third stage is transferring the data in TAP format to the TAP Engine via a socket connection.

Flight Trials

A download test of each data source was conducted through a web browser during charter flights. This download test was performed to resolve configuration issues. EDS ran normally during FT-2 evaluation flights by attempting to download external files according to a schedule defined in an EDS configuration file. Successful downloads were verified by checking that wind barbs were shown on the TAP Display. If winds were not shown then internet availability was verified and EDS was restarted. Verification of other data sources were confirmed by examining the EDS download folder on the TAP engineer laptop.

Objective 2 data collection was fully automated without the need for pilot or TAP engineer actions during flight. Four metrics were used to evaluate TAP's ability to obtain external data: percent of external files downloaded completely, latency between EDS request and remote server response, bandwidth consumed by downloads, and minutes after scheduled download time that data file is received by TAP.

EDS downloaded 60.5 MB during the 22 flight hours analyzed. The average performance of EDS and the internet system in terms of the success rate (79–89 percent), latency (4.8–5.7 seconds), bandwidth (0.76 KB per second), and minutes behind schedule (9.7 minutes) were acceptable for FT-2 and are expected to be improved with the significantly higher bandwidth of Alaska Airlines' Gogo internet system.

11.2.3. Objective 3: Assess the methodology to characterize TAP outcomes

The purpose of Objective 3 was to assess the completeness and effectiveness of a methodology developed to verify the accuracy and stability of TAP-computed outcomes, i.e., the predicted changes in flight time and fuel burn resulting from executing a given TAP-proposed route modification. The methodology uses TAP-recorded data, collected in-flight, to perform the verifications in a post-flight analysis. The plan was to use this methodology on data collected on partner airline flights during initial testing to verify TAP outcome performance before TAP is used by pilots for operational trials. The FT-2 objective was to dry-run the methodology to provide for any refinements if needed.

To verify the accuracy of TAP's predicted time- and fuel-to-destination savings, the methodology compares actual aircraft states to TAP predictions and generates fuel-burn and groundspeed error metrics. To verify solution stability, the methodology collects the time history of TAP-generated solutions (i.e., route modification advisories), allowing them to be qualitatively reviewed for stability issues. For example, the stability test uncovered an issue where successive runs of the TAP optimization algorithm returned slightly different solutions. Such occurrences are an inherent risk with a real-time (i.e., time constrained) application of a genetic algorithm. In cases where the second running of the algorithm was worse than the first, the stability plots showed that TAP was returning a sub-optimal solution. The TAP software was modified to refresh the outcomes for its previous advisory (after first checking that no new event invalidated the solution) and then to compare it to the latest result from the genetic algorithm. TAP would then return the more efficient solution of the two. This change resulted in a noticeable improvement in the stability of TAP solutions and computed outcomes.

Objective 3 data were successfully collected for all 12 evaluation flight segments. The new TAP TG algorithm [44], developed out of a need identified in FT-1, was brought online during FT-2. Extensive shakeout testing of the new TAP TG occurred using data from the first four FT-2 evaluation flights. During these four flights, TAP was reverted to using the FT-1 TG to

Flight Trials

successfully achieve the other FT-2 objectives. The data from these flights was still valuable to Objective 3 in refining the tools for identifying accuracy analysis segments.

The methodology for assessing the accuracy of TAP-computed outcomes required the identification of stable, level, un-accelerated flight segments for comparing TAP predications to recorded state data. The aircraft navigation system should have FMS lateral navigation engaged, and no FMS route changes should be executed during the segment. The original plan was to use 20-minute analysis intervals, a compromise between the preferred interval of 30 minutes and the expectation of shorter uninterrupted intervals due to route changes required for other FT-2 objectives. However, this would have resulted in only five usable 20-minute intervals over all 12 flights as there were a number of route changes made during each flight. Therefore the analysis was performed using 10-minute intervals resulting in 17 usable intervals.

For each interval, the analysis computed metrics to quantify TAP's prediction accuracy of fuel burn and flight time (represented as average ground speed) over the length of the segment. The final metrics are TAP Fuel Factor and Ground Speed (GS) % Error, calculated as shown in Eq. (1) and Eq. (2):

$$TAP \text{ Fuel Factor} = \frac{\text{actual burn rate}}{\text{predicted burn rate}} \quad (1)$$

where:

$$\text{actual burn rate} = \frac{\text{initial actual state weight} - \text{final actual state weight}}{\text{final actual state time} - \text{initial actual state time}}$$

$$\text{predicted burn rate} = \frac{\text{initial actual state weight} - \text{final predicted state weight}}{\text{final predicted state time} - \text{initial actual state time}}$$

$$GS \% \text{ Error} = \frac{\text{predicted average ground speed} - \text{actual average ground speed}}{\text{actual average ground speed}} \times 100 \quad (2)$$

where:

$$\text{actual average ground speed} = \frac{\text{actual along path distance over interval}}{\text{final actual state time} - \text{initial actual state time}}$$

$$\text{predicted average ground speed} = \frac{\text{predicted along path distance over interval}}{\text{final predicted state time} - \text{initial actual state time}}$$

These interval metrics are averaged over each flight, and these flight averages are then averaged over all flights to produced Average TAP Fuel Factor and Average GS % Error metrics for the particular aircraft being analyzed. For the fuel savings outcomes, the closer the Average TAP Fuel Factor is to 1, the more accurate the TAP outcomes are. This fuel factor was generated in a similar approach to the aircraft performance monitoring method used by airlines to adjust the fuel performance of their flight planning software and FMS. For the time savings outcomes, the closer the Average GS % Error is to zero, the more accurate the TAP outcomes are. Ground speed error has a direct effect on the time predictability of a flight. Because the time intervals used to generate this number in FT-2 were only 10 minutes, this number would not provide the full picture of time prediction for TAP. For example, the time prediction accuracy three hours ahead of the aircraft would be impacted much more significantly by the lack of accurate wind forecasts beyond those

Flight Trials

covered by the current RAP data (which updates every hour) than are these short predictions. Regardless, understanding the accuracy of these shorter predictions could help identify potential issues specific to TAP by highlighting larger than expected errors, and therefore short predictions were considered acceptable for this dry run of the methodology in FT-2. When later applied to the Alaska Airlines 737-900ER aircraft in the testing leading up to the operational evaluation, much longer stable flight-segment intervals were available.

Analysis of the eight flights using the new TAP TG was performed over the 17 intervals. The average TAP Fuel Factor for the Piaggio Avanti was 0.946 with minimum and maximum sub-interval values of 0.866 and 1.017, respectively. A value of 1 indicates a perfect prediction of the observed fuel burn. The calculated values were consistent with pilot feedback that the TAP TG fuel burn predictions appeared reasonable. It is likely that many errors in predicting fuel burn impact both the active route prediction and a proposed route change prediction in the same way, cancelling each other out when calculating fuel savings and thus not affecting accuracy in determining fuel savings.

The average GS % Error for the Piaggio Avanti was 0.170, with minimum and maximum sub-interval values of -4.935 and 6.380, respectively. A value of 0 indicates a perfect prediction of the ground speed, which is a direct measure of time required to cover a defined distance. On average, TAP was generally doing a good job in predicting ground speed and hence time-of-arrival estimates, but the minimum and maximum sub-interval values (5-6% error) were larger than expected. Further analysis determined that TAP's predicted Mach and calibrated airspeed (CAS) were significantly higher than the actual values, indicating an issue in the TAP Piaggio Avanti aircraft performance model when predicting cruise speed. It was determined that the speed change algorithm was insufficient to properly capture speed changes for the Piaggio Avanti which, during many flight segments, was not maintaining a constant Mach or CAS during cruise, but rather was maintaining a max power setting. As a result, the speed change algorithm was enhanced, and experience was gained in preparation for similar prediction accuracy analysis to be conducted in the upcoming airline operational evaluation.

In summary, Objective 3 to exercise the methodology for characterizing TAP computed outcomes and solutions was successfully met. The data collection was confirmed to be sufficient for the accuracy and stability analysis methods, and the analysis tools were refined to provide automated calculation of the desired metrics and visualization plots to support an analysis of the final results. The data collection and analysis tools were determined to be ready for conducting accuracy assessments using partner airline data.

11.2.4. Objective 4: Assess acceptability of TASAR to air traffic controllers

The purpose of Objective 4 (referred to as Objective 4A in reference [52]) was to gain insight on factors affecting route-modification request acceptability from the perspective of the air traffic controller. This objective aligns with one of the precepts of TASAR, that increasing the likelihood of ATC approval will ultimately increase the benefits achieved by the operator. TAP incorporates several design features with this precept in mind: avoid traffic conflicts, avoid incursion into active SUA, use published navigation aids, and limit requests to at most two off-route waypoints. In FT-2, Objective 4 aimed to affirm these design features and determine what additional features might be productive to include in future updates to the TAP software to increase likelihood of ATC approval.

Flight Trials

It is important to note that it is not the objective of TASAR to get all requests approved. While it is certainly a desired outcome, pursuit of ATC approval as the exclusive objective runs counter to TASAR's approach of leveraging the flexibility of ATC operations to optimize the flight. Some route modification requests are always unacceptable to controllers, such as ones that violate the separation requirement with another aircraft. Other acceptance criteria depend on characteristics of the airspace and the operating conditions at the time of the request. Building constraints into TAP's route optimization algorithms that account for all possible factors leading to a request denial would undermine the degrees of freedom that controllers have to approve requests, such as coordinating with another affected sector controller. TASAR leans on these ATC degrees of freedom to accommodate the operator's preferred route modification where practicable, while being respectful of known constraints that preclude the possibility of approval or that adversely affect the controller. In this way, TASAR intends to enhance the generally collaborative relationship between pilots and controllers to achieve greater efficiency in operations.

A challenge, however, is accommodating ATC acceptability factors when some of the critical information defining those factors is not readily available. For instance, sector maps are not generally published and available in electronic format, aircrews do not know when their handoff to the next sector controller is imminent, and Letters of Agreement (LOA) within and between ATC facilities that dictate controller requirements for delivering aircraft are not available to operators. Rather than attempt to obtain this information for prototype inclusion and testing in TAP, FT-2 took the approach of observing requests made in the absence of the information and interviewing controllers afterward on the importance of these acceptability factors.

FT-2 focused on gaining insights on two categories of controller acceptability factors:

1. Interaction with airspace structure such as sector boundaries and SUA
2. Maneuver complexity such as the number of waypoints and combo maneuvers

FT-2 also investigated the interaction between these and environment factors such as workload and traffic patterns. Outcomes of the analysis were recommendations for TAP advisory characteristics that address the identified acceptability factors.

As shown in Figure 22 (p81), FT-2 routes traversed ZTL and ZJX. Through advance coordination with the FAA and NATCA, a research team was stationed onsite at these facilities to observe aircraft interactions with ATC from the controller's perspective. The observations consisted of two components:



1. Observation of scripted route modification requests that were designed to test hypothesized acceptability factors and were made by the test pilot. Researchers monitored the pilot-controller communications during these requests and elicited acceptability factors from the controller through follow up interviews and questionnaires.
2. Observation of pilot-controller communications in sectors without the test aircraft traveling through and eliciting general acceptability factors through follow up interviews and questionnaires.

A list of hypothesized acceptability factors was generated and confirmed during preparatory visits to ZJX and ZTL. Two sets of factors were considered: controlled factors that were varied directly through scripted requests, and environment factors that were varied indirectly. Eight controlled factors representing airspace structure interactions and maneuver complexity levels are described in Table 12 (six factors are depicted graphically). The acceptability of the factors in

Flight Trials

Table 12 depends on uncontrolled environment factors, four of which are the controller who handles the request, traffic density, traffic flow type (arrival, departure, or en route), and workload. It was considered important to attain a variation in these uncontrolled factors such that they would not mask the effects of the controlled factors. Therefore, these factors were varied indirectly by flying at different times so that requests were made from different controllers and during different traffic patterns and densities. In addition to conducting morning and afternoon flights, the departure times were varied in the morning and afternoon to induce some variability of these uncontrolled factors.

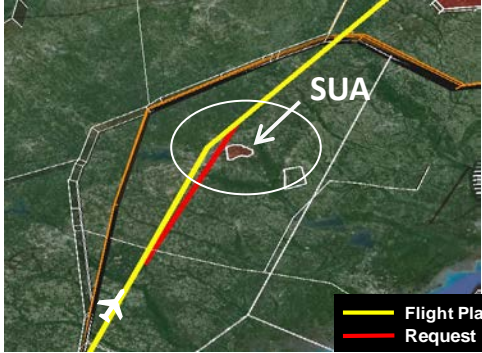
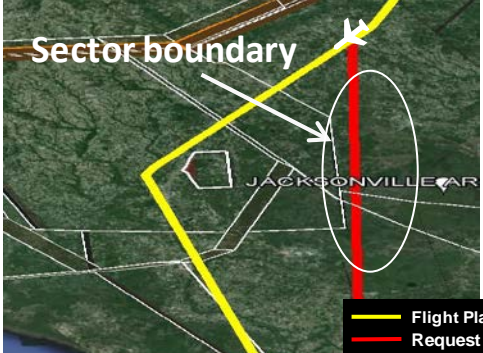
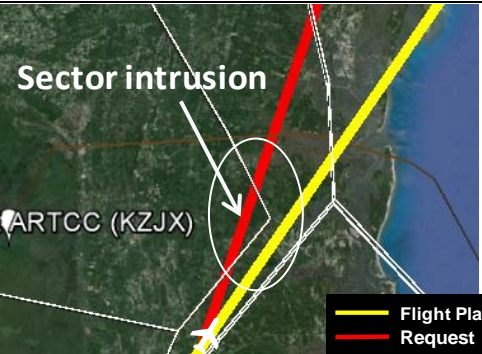
Table 12. Controlled ATC acceptability factors evaluated in FT-2. From ref. [53].

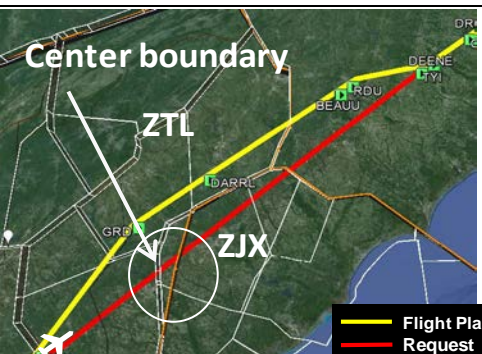
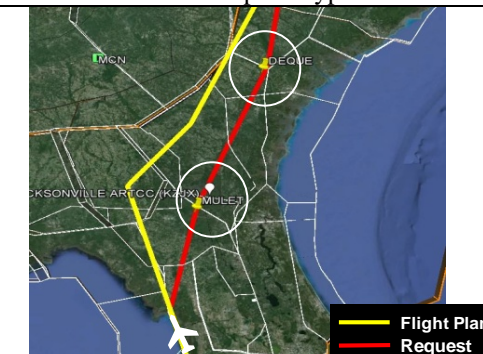
<p>1. SUA: Requests designed to fly close to three miles (typical buffer) from an SUA</p>	<p>2. Sector boundaries: Requests designed to fly along and across boundaries between sectors</p>
 <p style="text-align: right;"> — Flight Plan — Request </p>	 <p style="text-align: right;"> — Flight Plan — Request </p>
<p>3. Sector intrusion: Requests designed to cross in and out of sectors</p>	<p>4. Handoff: Requests made during or close to handoff status</p>
 <p style="text-align: right;"> — Flight Plan — Request </p>	 <p style="text-align: right;"> — Flight Plan — Request </p>
<p>5. Multiple centers: Requests made to cross from one center to another</p>	<p>6. Multiple waypoints: Request designed to include one and multiple waypoints</p>
 <p style="text-align: right;"> — Flight Plan — Request </p>	 <p style="text-align: right;"> — Flight Plan — Request </p>
<p>7. Multiple maneuvers: Request designed to include altitude and lateral maneuvers</p>	<p>8. Fix type: Request designed to use fixes in low altitude (E class) in addition to high altitude</p>

Flight Trials

To invoke the factors in Table 12, scripted requests (rather than TAP-generated requests) were employed, and detailed scenarios were designed for each request. The scenarios were collected in a booklet that was used by the ground observers and the TAP engineer onboard who was in charge of planning and timing the requests. The scenario order was determined by the ground observers before each flight and communicated to the TAP engineer onboard such that the two teams were coordinated at the start of each flight.

For observations of the test aircraft, one observer shadowed the controller of the sector where the flight was traveling and making requests. Once the next sector along the flight's route was determined with high certainty (but before handoff) the other observer started shadowing the controller of the next sector in anticipation of the flight's arrival. Some flights made fewer than three requests and some flights made up to four requests. Some factors that were concluded quickly as non-important were de-emphasized, such as the class of the fix used in a request (factor 8 in Table 12). ATC facility personnel assisting the ground-based research team were instrumental in helping to modify the scripted scenarios based on their knowledge of procedures, common controller behavior, and the forecast weather for the day.

Detailed results of the ATC observations for Objective 4 are presented in reference [53]. A total of 36 route modification requests were made during the flight trial. Three requests were made in Washington Center airspace where no observers were present. Seven requests were made according to TAP advisories, 28 requests were made according to scripted scenarios designed to invoke the factors in Table 12, and one request related to an evolving weather event was not scripted beforehand but rather was planned during the test. Of the 36 requests, eight were rejected due to various factors (handoff status, unfamiliar fix in request, opposing traffic stream, holding in the next sector due to weather, intrusion of recently activated SUA, proximity to airspace boundaries, incursion into another center, request counter to ATC facility letter of agreement) that are further detailed in reference [53]. Nine were accepted with a delay; for example, the request was rejected first and then accepted after the controller conducted needed coordination or resolved any traffic implications due to the request. The remaining nineteen requests were accepted with no significant observed issues.

With the help of the facility personnel assisting the observers, interviews with the observed controllers were scheduled (in consultation with the supervisors) after the flight exited from the sectors of interest. The main data source for identifying and characterizing controller acceptability of pilot requests was the interviews with the controllers. Fifty controllers were interviewed, 35 in ZTL and 15 in ZJX. Four types of information were collected from each interviewed controller: (1) demographic information; (2) general request acceptability statistics and factors; (3) information regarding observed events, mostly events related to the scripted scenarios; and (4) information regarding the hypothesized acceptability factors. Assessment of each factor was obtained from each interviewed controller under three subjective workload levels (high, moderate, and low) as individually defined by each controller.

The controllers estimated that 30 to 50 percent of pilots make requests in nominal conditions, increasing to over 90 percent under bad weather and turbulent conditions. The most common requests are short cuts, followed by altitude change requests, and then weather deviation requests. By far, traffic conflict was mentioned the most frequently by controllers as the first factor they

Flight Trials

consider when evaluating pilot requests. Other factors ranked as important were arrival/departure flow interactions, flow restrictions, and workload. Most controllers said they reject less than 10 percent of pilot requests, with all responses below 50 percent. Traffic confliction was the dominant reason for rejecting a request.

The following nine summaries describe insights and recommendations about hypothesized controller acceptability factors. These results derive from observations, controller interview data, and analyses of specific scenarios observed in FT-2 and detailed in reference [53].

Request to fly close to active SUA

Controllers were asked how close a route modification request can be to an active SUA and still be acceptable. The required minimum separation from an active SUA is 3 nmi. The majority of controllers answered that they would accept requests that are at the legal minimum distance of 3 nmi under low workload, but they require 5 nmi under high workload. This response is one of many where controller workload was a determining factor in acceptability. No mechanism and data source is currently available for informing TAP of the controller's workload state. Until these exist, it will be up to the pilot's judgment to make any adjustments to accommodate controller workload.

Request to fly along sector boundaries

Controllers were asked how close to the boundary between two sectors can a requested trajectory travel in order to be acceptable. The main issue with flying close to the boundary between sectors is the necessity of a "point out." If an aircraft flies closer than 2.5 nmi from a sector boundary, the controller in charge of the aircraft has to call the controller of the adjacent sector to have him/her monitor the aircraft as well. This procedure is known as a "point out" and causes an increase in workload. Although it is very common for controllers to point aircraft out, under high workload they can decide to either reject or delay a request that needs a point out in order to create enough separation from the sector boundaries and avoid the coordination necessary for the point out. Most controllers, in all workload situations, indicated they would accept a request that has the aircraft flying along the boundary between two sectors (requiring a point out) though the desired separation from sector boundaries increased at high workload.

Request causing sector intrusion

Controllers were asked if they would accept requests that intrude briefly into another sector (clip a sector) and, if not, how far they would want a request to be to avoid clipping. The issue in clipping a sector is causing a point out to the clipped sector similarly to the previous factor (flying along sector boundaries). Controllers are required to point out an aircraft that clips a sector, potentially adding workload to the controllers of the sector that is being clipped and to their own because of the coordination it requires. To avoid the point out, as explained for the previous factor, controllers would have to keep the aircraft more than 2.5 nmi away from the adjacent sector's boundaries. The majority of controllers answered that they would accept requests that clip sector boundaries (requiring a point out) regardless of workload. Based on the smaller emphasis of the controllers' responses on maintaining distance from sector clipping compared to when flying along boundaries, it is more acceptable that a route modification request does not take into consideration the clipping of a sector if that provides an optimal solution.

Flight Trials

Time of request before handoff to next sector

Controllers were asked how close they would allow the aircraft to be to its handoff to the next sector while still accepting a request, rather than telling the pilot to make the request to the next sector. Controllers are required to hand off an aircraft to the next sector when the aircraft is still in their airspace. If they forget to hand off an aircraft, the system will automatically flash the aircraft when within 3 nmi from the sector boundaries. If the controller of the next sector takes the handoff, he/she may not be talking to the aircraft yet, but the control of the aircraft has been taken. For this reason, it frequently happens that a pilot makes a request to a controller who is not in control of the aircraft anymore. This happens close to the handoff because pilots have no awareness of the sector boundaries or the status of the handoff procedure. If a request is made in this situation, the controller has to call the controller of the next sector and ask to hand the aircraft back to her/him, introducing additional workload. Controllers responded they desired requests be made 2–5 minutes prior to handoff initiation, depending on current workload. To accommodate this constraint, TAP would require a sector map and logic to estimate proximity to handoff. The additional software complexity this introduces may not be beneficial, given that pilots will simply be informed to make the request to the next controller.

Time of request after handoff from sector

Controllers were asked how soon after they receive the handoff from another sector they would entertain a trajectory change request. Based on the controllers' responses, this factor was characterized by two parameters: (1) the acceptable request time after the handoff and (2) the acceptable request distance after crossing the sector boundary. Most controllers preferred knowing a request immediately after the handoff, even under high workload, which helps them in planning for the request. If the requesting aircraft is not in his/her airspace yet, the controller has the option to delay the response. If the trajectory change request is urgent, for example for weather deviation, the controller has the option to call the controller of the previous sector and ask to obtain control for maneuvering the aircraft. In this way the controller can accommodate the request right away but with added workload. This situation arises again because of the lack of knowledge of the sector boundaries by the pilots. The majority of controllers replied that they would handle the request once the aircraft is in their controlled airspace (zero distance from the boundary). If a sector map is incorporated into TAP, an estimation of the effect of this delayed approval could be incorporated into the outcome computations, though with little practical benefit. Under low workload, most controllers replied that they do not mind calling the previous controller and asking permission to handle the request early, which is typically granted.

Time of request before handoff to next center

Controllers were asked how close they would allow the aircraft to be to its handoff to another Air Route Traffic Control Center (ARTCC) while still accepting a request, rather than telling the pilot to make the request to the next center. The situation is analogous to handoffs to sectors, except that the receiving sector controller is located in another facility. During the interviews controllers repeatedly stated that, while historically the handoff to another center had been more problematic, with the En Route Automation Modernization (ERAM) the handoff to another center is as simple as the handoff to another sector inside their own center. Therefore no accommodation is needed to distinguish between sector and center handoffs.

Flight Trials

Request with additional waypoints

Controllers were asked how many additional waypoints (beyond a simple “direct” to a downstream waypoint) they would accept in a route modification request. The majority of controllers responded that under high workload they would accept two additional waypoints or four or five additional waypoints under low workload. TAP’s current design of adding at most two additional waypoints is therefore acceptable even under high ATC workload. In fact, through the interview, most controllers replied that under low workload levels they would not have any problem in changing the entire route of a flight. Controllers also replied that the number of acceptable waypoints to be added to a route depends on how familiar they are with the waypoints. The more familiar they are, the easier it is for them to add these waypoints to the route.

Request with combined lateral and vertical maneuvers

Controllers were asked if a route modification request that includes both lateral and vertical components is acceptable under different workload conditions. No quantitative data were presented in reference [53] for this factor because most controllers answered that the combination of lateral and vertical maneuvers does not constitute a problem. TAP’s current design of producing combo solutions is therefore acceptable. Sometimes moving to a different altitude could even be advantageous for their workload. Some controllers replied that it can only become an issue if the altitude part of the request puts the aircraft in a different stratum of airspace. In that case, they have to hand the aircraft off to another sector, either above or below them, adding to their workload.

Request with unfamiliar waypoints

Controllers were asked if a trajectory change request that includes Class E (low altitude) waypoints is acceptable when flying in Class A (en-route) airspace under different workload conditions. No quantitative data were presented in reference [53] for this factor because almost all the controllers answered that the airspace class is irrelevant as long as the waypoint’s name is in the system. Some controllers replied that the familiarity with the waypoints can be an issue. If a request includes a waypoint that they are not familiar with, their workload increases because they need to search for the waypoint’s location to assess the impact of the route modification. TAP’s use of waypoints that are sometimes unfamiliar may occasionally result in a rejected request, as was experienced on a couple of occasions in FT-2.

In summary, the Objective 4 analysis led to the following determinations: Incorporation of a sector map into TAP and associated logic to minimize airspace structure factors (e.g., sector clipping, handoff impacts) may increase request approval rates under conditions of high controller workload, but the challenges of identifying these conditions and the limited availability of relevant data sources (e.g., up-to-date sector maps, LOAs) did not warrant implementing these functions in TAP during this project. Indeed, all of the controllers interviewed showed an enthusiastic reaction to the possibility of pilots being aware of the sector boundaries and accounting for them in making their requests. However, it was not determined to be currently practical to implement. It may be prudent to put a greater emphasis on integrating TAP with Data Comm, which will facilitate a number of the ATC acceptability factors identified here.

11.2.5. Objective 5: Assess acceptability of TAP advisories to airline pilots

The purpose of Objective 5 (Objective 4B in reference [52]) was to identify characteristics of TAP’s route modification advisories that may impact acceptability to pilots. These characteristics included those associated with the complexity and the geometry of the computed solutions. The

Flight Trials

Table 13. Complexity characteristics of TAP route modification advisories.

Dimension	Advisory Complexity	Example Advisory
Lateral	Direct to FMS waypoint only	RJOIN
Lateral	One off-route waypoint + FMS rejoin waypoint	OFRT1 RJOIN
Lateral	Two off-route waypoints + FMS rejoin waypoint	OFRT1 OFRT2 RJOIN
Vertical	Altitude change only	FL350
Combo	Altitude change + Direct to FMS waypoint only	FL350 RJOIN
Combo	Altitude change + One off-route waypoint + FMS rejoin waypoint	FL350 OFRT1 RJOIN
Combo	Altitude change + Two off-route waypoints + FMS rejoin waypoint	FL350 OFRT1 OFRT2 RJOIN

proximity of solutions to weather or SUA were not included in this assessment primarily because of the lack of control of these variables in the flight test.

The complexity of TAP solutions is characterized by the number of waypoints and whether an altitude change is included, as shown in Table 13. Complexity is also dictated by the type and familiarity of off-route waypoints. TAP uses common navigation aids like the Very-high-frequency Omnidirectional Range (VOR) and five-letter intersections and fixes found on en-route charts, as well as the less common five-character NRS waypoints established on a latitude-longitude grid. Pilots (and controllers) are generally familiar with the VORs and some intersections on routes they frequent, but they may need to phonetically spell out less common waypoints. In such situations, the quantity of off-route waypoints may become a limiting factor for acceptability in a voice-communications environment.

Defining the geometry of TAP solutions are several variables dictating the time, distance, or turn angle along various legs as shown in Figure 24. Specifically, these include:

- δ_m : time or distance from present position to initial turn
- d_m , d_c , and d_r : time or distance between waypoints
- θ , γ , β , α : trajectory turn angles

Unlike in Manual Mode, TAP's Auto Mode does not enable the pilot to control the time, distance, or turn angle variables directly. Rather, TAP optimal solutions are automatically found using any combination of these geometric characteristics within predefined limits.

To assess these complexity and geometry characteristics, evaluation pilots were given the opportunity to evaluate TAP advisories as they naturally occurred during the flights. The planned routes were sufficiently sub-optimal that TAP frequently provided solutions. Though the short flight lengths, general lack of weather, and non-uniform winds produced few opportunities to evaluate the more complex solutions, a sufficient number occurred and enabled feedback from the evaluation pilots on solution acceptability. Feedback was provided primarily through in-flight and post-flight questionnaires. Detailed results are presented in reference [52]. A general summary of findings are presented here.

Flight Trials

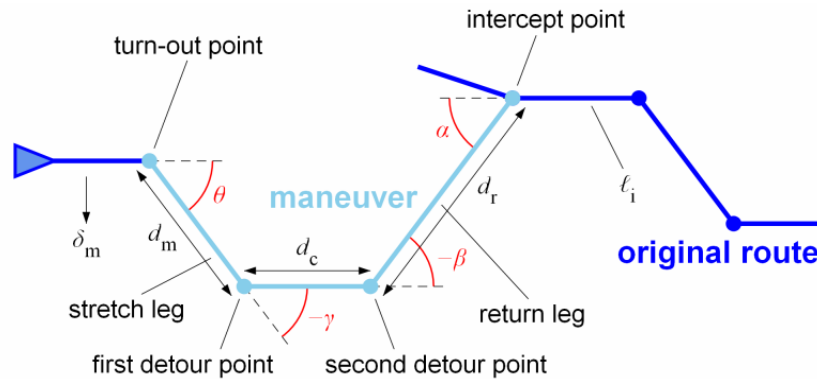

Figure 24. Geometry characteristics of TAP solutions.

Pilot feedback indicated that the range of complexity of TAP advisories in Table 13 was acceptable for a voice environment but should not increase in complexity until a Data Comm environment is available. Most pilots agreed that two off-route waypoints was the maximum that TAP should provide, which is consistent with air traffic controller preference for high-workload situations (Objective 4 finding). Pilots (like controllers) found combo requests (with both lateral and vertical components) to be acceptable, even though it is not common practice to make such requests today. The use of common and less common waypoints was also considered acceptable, though most pilots recommended against using Class E (low altitude) fixes when flying in Class A (high altitude) airspace.

Pilots found the geometry characteristics of time/distance between waypoints and turn angles to be acceptable. Time/distance to the initial turn point was generally acceptable but occasionally too small. Their feedback was that the first fix in the solution should be far enough away to allow for reasonable decision-making time, ATC communications, and other operational delays. At least one actual request in FT-2 did not meet this criteria and had to be modified after a delayed ATC response. Comments were also received on TAP's selection of altitudes, suggesting that pilots be allowed to define selectable ranges or a maximum altitude. A maximum altitude control was subsequently added to TAP. Pilots also suggested a new capability whereby TAP could generate solutions that start at a future point along the FMS route.

11.2.6. Objective 6: Assess TAP user interface

The purpose of Objective 6 (Objective 5 in reference [52]) was to assess workload, SA, and usability of the TAP user interface (referred to here as the Human Machine Interface, or HMI), as hosted on an iPad, during flight operations. The HMI tested in FT-2 (TAP v15-2) was essentially the same as that tested in HITL-2 (TAP v14-1), shown in Figure 15 (p63). However in addition to testing this landscape orientation of the HMI design, a portrait orientation (Figure 25) was implemented and tested as well in FT-2. The reason for two orientations was to accommodate the preferences of airline pilots that would use TAP in the upcoming airline operational evaluation. Pilots have the choice of landscape or portrait orientation when mounting their EFB interface (iPad) in the cockpit. Since switching between TAP and other EFB applications was expected to occur frequently in flight, a portrait mode option was added to accommodate pilots with that preference and to avoid the need for physically reorienting the hardware during flight. The TAP

Flight Trials



(a) Auto Mode screen.

(b) Manual Mode screen.

Figure 25. TAP v15-2 user interface tested in FT-2, shown in portrait mode.

Display software was developed to automatically switch between landscape and portrait according to the device's internal orientation sensor.

Before departure on the test flights, the evaluation pilots were provided training consisting of a Flight Operations Bulletin (FOB) and a CBT module. The FOB contained a detailed description of the TAP software application, general information about how TAP works, and instructions regarding the operation of TAP. The CBT (Figure 16, p64) was a 30-minute interactive, stand-alone training module administered on an iPad. The CBT included voice-over narration demonstrating each of the features and functions of the TAP HMI.

Once airborne and shortly after the aircraft passed 10,000 feet where TAP becomes operational, the evaluation pilots began their interaction with the TAP HMI according to a set of predefined tasks enabling them to interact with each of the HMI features. This procedure enabled the evaluation pilots to comprehensively familiarize themselves with the TAP HMI in an operational flight environment before performing a formal evaluation approximately one hour into the flight. In-flight questionnaires included the Bedford Workload Scale, the Situation Awareness Rating Technique (SART), and the System Usability Scale (SUS). Post-flight questionnaires included the Bedford Workload Scale, the SART, and the TAP HMI evaluation. References [52] and [54] contain descriptions and references for these subjective measures along with complete findings of the Objective 6 analysis. Selected results are provided below.

The Bedford Workload Scale ratings were analyzed to measure perceived pilot workload in performing tasks with the TAP HMI. As depicted in Figure 26(a), the evaluation pilots reported their cognitive workload as low ($M = 2.64$, $SD = 0.84$) in terms of the Bedford scale of 1–10, with

Flight Trials

a rating of 1 indicating insignificant workload and a rating of 10 indicating a very high level of workload and task abandonment. A median of 3 indicates that interaction with the TAP HMI during FT-2 did not create a significant level of workload and that most pilots had spare capacity and completed their tasks satisfactorily.

The calculated scores from the SART were analyzed to measure perceived SA in performing tasks with the TAP HMI. As depicted in Figure 26(b), the evaluation pilots reported mid-range SA scores ($M = 7.93$, $SD = 2.95$) in terms of SART scoring (1–14), indicating a nominal level of situation awareness with the TAP HMI present during FT-2.

The SUS yields a single calculated score representing a composite measure of the overall usability of the system being evaluated. As depicted in Figure 26(c), the evaluation pilots provided high usability ratings for the TAP HMI ($M = 80.0$, $SD = 14.33$) in terms of SUS scoring, indicating a high degree of perceived usability of the interface used during FT-2.

The post-flight questionnaire consisted of five-point rating scales regarding overall comprehension, usefulness, and usability of the TAP HMI as well as questions about specific display features. The overall ratings for each of the three display screens (Startup Checklist Screen, Auto Mode Screen, and Manual Mode Screen) are shown in Figure 27. For all three categories, 5 was the most positive rating and 1 was the most negative rating. The overall ratings were generally very high. Specifically for the Startup Checklist and Auto Mode Screens, the pilots reported that the comprehension of the display screens was either Easy or Very Easy ($M = 4.43$, 4.79 ; $SD = 0.76$, 0.43 , respectively). The Manual Mode Screen was found to be slightly less

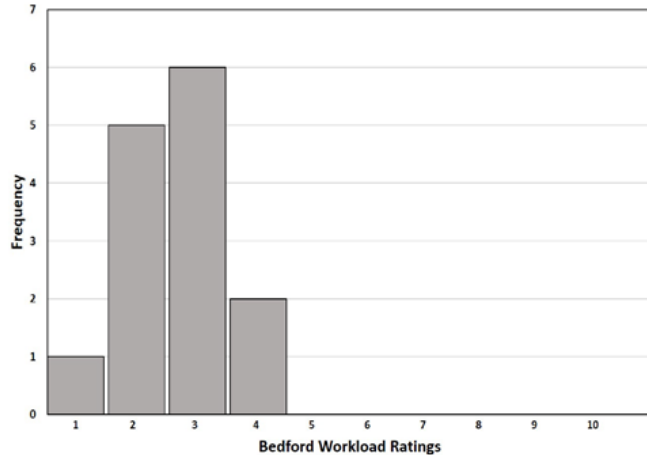

(a) Workload.

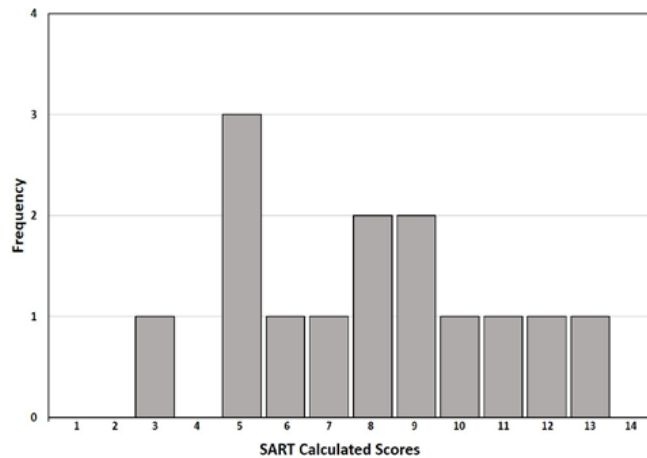

(b) Situation awareness.

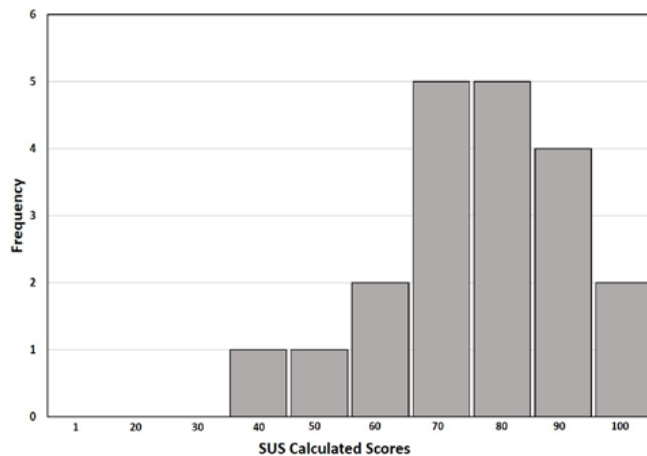

(c) System usability.

Figure 26. FT-2 pilot subjective ratings of using TAP. From ref. [54].

Flight Trials

comprehensible ($M = 3.86$, $SD = 0.86$), with 43 percent of pilots reporting that comprehension was Somewhat Easy. All three display screens were found to be either Useful or Very Useful, and either Usable or Very Usable.

Pilot ratings of individual display features were generally high. Mean ratings were above 4.0 for nearly all display features except three features rated as either Not Useful or Somewhat Useful: cruise settings, data feeds menu, and ATC response buttons. The data feeds menu provides information on the status of external data (winds, weather, and SUA), and the ATC response buttons have no operational function and were included only to aid post-flight data analysis. The concern was the cruise settings rating. These settings (cruise altitude and cruise speed) are important inputs that depend on pilots keeping them up to date with settings in the FMS (which were not automatically transmitted to TAP in the test aircraft). Incorrect values could significantly affect TAP's computation of time and fuel outcomes and therefore pilot decisions about TAP advisories. The issue would emerge again in the operational evaluation with Alaska Airlines, for which cruise settings were also not automatically available from the FMS, prompting the development of an automated altitude and speed tracking algorithm.

In summary for Objective 6, the evaluation pilots reported their cognitive workload as low, indicating that interaction with the TAP HMI did not create a significant level of workload and that most pilots were able to complete their tasks satisfactorily. The evaluation pilots rated the TAP HMI as having a high degree of usability. A nominal level of SA was indicated with the TAP HMI. However, when asked about SA on the post-flight questionnaire, the pilots indicated that TAP enhanced their SA in the cockpit. Overall ratings of comprehension, usefulness, and usability of the HMI display screens and display features were generally high. As a result of this analysis, no significant HMI changes were deemed necessary prior to the deployment to Alaska Airlines for the operational evaluation. As will be described, some changes were made during that evaluation, particularly in the area of weather data depiction, which was not yet fully developed by the time of FT-2.

11.2.7. Objective 7: Assess effect of TAP on flight crews and CRM

The purpose of Objective 7 (Objective 6 in reference [52]) was to gather insights and develop recommendations on the use of TAP by a two-person flight crew. Coordination between flight crew members, commonly referred to as Crew Resource Management, is important to maintaining an effective distribution of tasks and workload while ensuring common SA between the crew members. Some cockpit systems are designed to display synchronized information on multiple displays, which aids CRM. As a research prototype, TAP was developed with only a single display. Since the EFBs are typically mounted near each pilot's side window, viewing a TAP display from across the cockpit would be difficult and thereby complicate coordination. An alternative is to have two instances of TAP running, one on each pilot's EFB. However, since the prototype software supports only one display, the two instances would have unsynchronized data, even though they

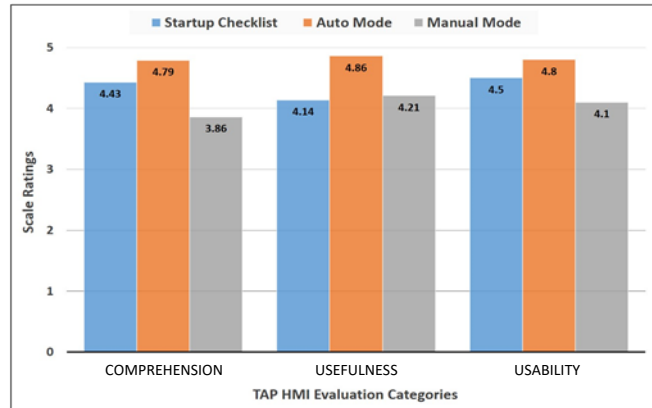

Figure 27. FT-2 ratings of the three primary TAP Display screens. From ref. [54].

Flight Trials

share the same inputs. Thus, in preparation for the airline operational evaluations, a study of the CRM aspects of TAP usage was included in FT-2.

The 12 evaluation flights in FT-2 were conducted as single-pilot operations, made possible by the Piaggio Avanti being certified for such operations. The safety pilot in the left seat was formally responsible for all cockpit duties, even though some duties were delegated to the evaluation pilot in the right seat to simulate PM workload. However, a CRM evaluation could not be properly conducted in this environment because the two pilots were not formally trained to a set of Avanti Standard Operating Procedures (SOP), and no evaluation pilots were Avanti qualified.

In an alternate approach, TAP usage was evaluated in an airline-representative two-crew CRM environment using two type-certified Piaggio Avanti captains, using the same SOPs and CRM practices that are employed for public transport flights in the Avanti. The CRM evaluations were conducted during the two positioning flights between the aircraft’s Montreal home base (CYUL) and KPHF. The majority of data were collected during the southbound flight. Limitations in the number and type of Canadian airspace fixes in TAP’s ARINC 424 database caused operational issues during the northbound flight to Montreal. This was not a problem during the southbound flight because TAP was not used operationally before entry into U.S. airspace, and a full set of fixes were available to the software at that time. On the northbound leg, many of the vital “look ahead” fixes, including the destination airport, lay in Canadian airspace, for which there was limited database coverage.

A build-up approach was used to explore all major TAP operational functionality, under every permutation of Manual/Auto Modes and PF/PM operations, as shown in Table 14. Various subjective evaluations of workload, CRM effectiveness, SA, Multi-Function Display (MFD) and cross-checking acceptability were performed. TAP procedure timing was also objectively measured. Apart from TAP usage, PM duties included the following: cross-check autopilot modes, program the FMS, cross-check altitudes, make radio calls, read checklists, confirm pilot checklist items, and perform copilot checklist items. PF duties included the following: control autopilot; cross-check FMS entry; enter altitude pre-selector values; perform pilot checklist items and confirm copilot checklist items. Either or both operators may operate the radar and MFD as needed.

Table 14. TAP CRM configurations evaluated in FT-2.

Test #	TAP Operator	TAP Modes	Evaluations
1	PM only	Manual Mode	Workload, SA, and MFD
2	PM only	Auto Mode	Workload, CRM, SA, and timing
3	PF (secondary) PM (primary)	Manual and Auto Modes	Workload, CRM, SA and timing
4	PF (primary) PM (secondary)	Manual and Auto Modes	Workload, CRM, SA and timing
5	PF only	Auto Mode	Workload, CRM, SA, timing, and MFD
6	PF only	Manual Mode	Workload, CRM, SA, timing, and MFD

Flight Trials

A combination of in-flight and post-flight subjective data were obtained for each CRM mission. Detailed results are presented in reference [52]. Primary conclusions are presented below.

In summary, the CRM evaluation demonstrated the utility and usability of TAP for two-crew CRM and SOP operations. Almost all combinations of single-pilot TAP operations subjectively reduced crew workload and optimization planning / execution times relative to the crew's frequent operating experience without TAP. Conversely, dual independent TAP operations created difficulties in attempting to synchronize the two sides of the cockpit, which adversely impacted CRM. Both the PF and PM stressed the need to be able to synchronize to a single solution in these circumstances. Although individual control of display settings, such as layers and scale factors, was deemed desirable, neither pilot saw any benefit in having independent and differing Auto Mode solutions. In fact, this decreased confidence in the system, increased workload, and reduced SA relative to single-pilot TAP operations. An important mitigation for this phenomenon would be to develop TAP SOPs whereby crews become accustomed to calling out the TAP mode, display range, and optimization limit, while coordinating solutions across the cockpit. This is identical to existing SOPs for coordinating FMS and autopilot/flight director mode changes. The far more preferable solution, however, would be to implement a bi-direction cross-fill/synchronization capability between the displays, similar to current FMS implementations.

Subsequent to FT-2, and as a result of these CRM recommendations, a design effort was initiated to develop TAP to support two TAP Displays, using a master-slave approach. Since project resources were not available to implement the design, the CRM findings were communicated to Alaska Airlines with the recommendation to use only a single instance of TAP on flights in the operational evaluation (a recommendation generally followed).

11.3. TASAR Flight Trial 3

One element of TAP functionality not fully developed or evaluated in FT-2 was the handling of weather data. The one element of weather data included in FT-2 as a proof of concept was convective SIGMET polygons as received from WSI (Alaska Airlines' approved commercial weather provider). FT-2 verified that weather polygons from a third-party weather data provider could be received in flight and displayed in TAP. However, the convective SIGMETs published during FT-2 flights happened to be positioned on the far side of the destination airports and therefore were untestable with TAP's conflict detection and route optimization algorithms. More critically, a significant gap remained in TAP's external data sources for weather, as no commercial or government weather data providers offered the polygon products (apart from SIGMETs) that TAP would need for representing current and forecast convective weather constraints. These products would be derived from radar reflectivity data or models covering the next two hours of flight. They would be a higher fidelity representation of the weather than SIGMETs and critical to include in the upcoming airline operational evaluations, given the significant interactions expected between route optimization and weather constraints on the airline flights. It became clear that NASA would need to provide a temporary data source for convective weather polygons for the operational evaluation, which later could be replaced by commercial products for regular operational use. NASA's implementation of convective weather polygons, implemented through an enhancement to the functionality of the Ground Data Server (GDS), is described in reference [45].

While the inclusion of GDS weather polygons filled this critical need, there was a concern that the ground-based weather products alone may be insufficient. Airline pilots are responsible for

Flight Trials

keeping their aircraft clear of weather hazards, and the principal tool they use is onboard weather radar. While TAP is not a weather avoidance tool, it is intended to provide route optimization advisories that flight crews will find operationally acceptable, and weather compatibility is one key aspect of flight crew acceptability. This raised a concern that TAP route modification advisories might be unacceptable in the vicinity of convective weather if airborne weather radar data were not included in the advisory generation.

Given these weather data issues, a third TASAR flight trial was planned focusing on integration, display, and use of weather data in TAP. FT-3 would be conducted prior to and concurrent with the airline operational evaluation. It would study the operational implications of each weather data source (e.g., ground, airborne, current, forecast) and assess various designs for their integration. These weather integration designs would address algorithmic integration as well as presentation and user interaction. Considerations would include appropriate look-ahead times, blending or overlay of weather data from disparate sources, and depicting 4D weather information on a two-dimensional (2D) display.

To conduct FT-3 with greater research flexibility over an extended testing period than was possible with the Piaggio Avanti, a NASA flight-test aircraft (HU-25A Guardian operating as “NASA 524” and shown in Figure 28) was selected and outfitted for TASAR flight testing. The role of the HU-25A in the larger suite of TAP software test facilities is described in reference [55], and the specific implementation and execution of TAP flight-testing in the HU-25A is described in reference [56]. Due to changes in programmatic funding and priorities, FT-3 was not completed as planned. However a number of key accomplishments were achieved and are noted in the following sections.



Figure 28. NASA HU-25A Guardian flight test aircraft used in FT-3. From ref. [56].

11.3.1. Ground-based Convective Weather Data

TAP’s optimization algorithms are designed to generate route modifications that are free of conflicts with a variety of hazard areas described by 4D polygons, including SUAs and convective weather. Each polygon is a prism described by a lateral shape that is extruded from the ground up to a given ceiling altitude. Its time of validity is defined as an interval bounded by specified activation and expiration times. A trajectory is considered to be in conflict with a 4D polygon if the aircraft is predicted to be within the polygon volume at any point during its time of validity. TAP filters the candidate trajectories it generates to ensure that the reroute advisories shown to the aircrew are free of conflicts with the current set of 4D polygons.

Flight Trials

While TAP downloads wind and temperature data directly from the NOAA website via the aircraft's airborne internet connection, it relies on a ground-based processor known as the Ground Data Server (GDS) to provide 4D weather polygons generated based on other ground-based data sources. Developed by NASA for this project, the GDS served as a post-processor of the data obtained from a commercial weather service provider, in this case The Weather Company (formerly WSI), and provided it in suitable polygon format to the EDS running onboard the aircraft, via the internet. Details of GDS polygon generation are presented in reference [45]. Examples of current and 15-minute-forecast convective weather polygons generated by GDS are shown in Figure 29.

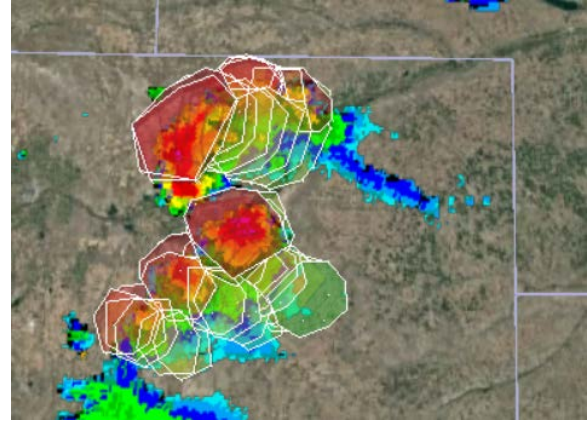

Figure 29. GDS convective weather polygons.
Base image from Google Earth™.

A weather implementation issue studied in FT-3 was the application of lateral buffers to the convective weather polygons. TAP assumes that the polygons already contain any operationally-required buffer, as it does not add any additional spacing between candidate route modifications and the polygons. Initial FT-3 test flights were conducted with 20 nmi buffers, consistent with typical operational buffers applied by pilots in weather avoidance. The flight tests showed that non-discriminating application of the 20 nmi buffer was operationally unrealistic, greatly reducing TAP's utility in the context of decision-making flexibility typically applied by pilots in weather avoidance. Alaska Airlines recommended the lateral buffers be reduced to 5 nmi, leaving pilots to apply standard operating procedures for weather avoidance, as they do already with route selection using airborne weather radar. Subsequent flights using the TAP software on both the HU-25A and on Alaska Airlines' aircraft offered confirmation that the 5 nmi lateral buffer, in conjunction with the aircrew maintaining separation from the weather, provides a safe and realistic mechanism for optimizing flights near convective weather.

11.3.2. Airborne Convective Weather Data

To address the concern that TAP's use of only ground data sources for convective weather data may produce unacceptable route modifications, an activity was initiated in FT-3 to develop and evaluate a prototype implementation in TAP of polygons derived from an airborne weather radar system. The objective was to determine guidelines for integrating airborne and ground-based weather data into TAP, exploring the issue from both the algorithmic and user interface perspectives. To conduct the research, a prototype "airborne weather radar processor" (AWRP) was developed that converted radar imagery (received from a radar display bus in ARINC 708 format) into simplified polygons. The polygons were then supplied to TAP as a separate input from ground-based weather polygons. Details of the AWRP implementation are described in reference [45]. Example AWRP polygons are shown in Figure 30.

Though a change in project funding and priorities precluded flight-testing the integrated capability, issues were identified that would need to be addressed in an operational implementation. For example, some airborne weather radar systems produce imagery that is highly dependent on manual tilt and gain settings, making TAP's behavior inherently reliant on the pilot's

Flight Trials

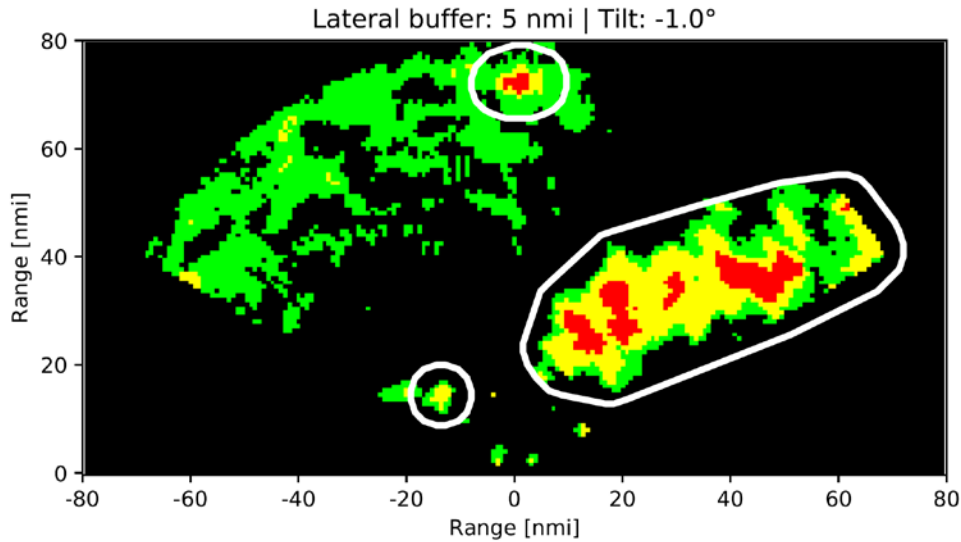

Figure 30. Airborne weather radar data and polygons generated by AWRP. From ref. [45].

interaction with the radar. Newer multi-scanning radar systems overcome this limitation but are not typically designed to export the volumetric models of the convective activity to external applications. Issues of range and attenuation are also expected to be significant factors in designing an effective integration of airborne and ground-based weather data in TAP.

11.3.3. Integration of Weather Data into the TAP HMI

In contrast to state-of-the-art weather information display applications that typically present dozens of weather products overlaid on a map of the geographic region of interest, the design goal of the TAP HMI was to present only enough contextual information to the pilot to enhance understanding and trust in TAP's recommended route modifications. Though the result was a generally "minimalist" display design, it was rated highly in FT-2 for comprehension, usefulness, and usability [54]. However, FT-2 did not include much weather information for the assessment, and therefore, FT-3 was planned in order to fill this assessment gap. Discussion of TAP HMI design changes to accommodate the depiction and interaction with weather information is presented in reference [45].

One significant HMI design element emerging from FT-3 prototyping and evaluation was a new "time slider" control to depict 4D weather information on a 2D display. The fundamental human factors challenge was to overcome how the user perceives the polygons on the display, even if the polygons representing different weather types (e.g., current and forecast weather) are drawn differently. When current and forecast polygons appear on the display at the same time next to the route information, the user is likely to immediately perceive them all as "now." So if a TAP-generated trajectory is drawn through a forecast weather polygon without indicating a conflict, it can be confusing to the user because it is not intuitive that the polygon is representing weather that will not be relevant to the trajectory when the aircraft arrives at that point in time.

A reasonable solution was developed and tested in FT-3 by incorporating a functional tool (i.e., the time slider) that allowed the pilot to select increments of time to be displayed as opposed to displaying all of the weather polygons simultaneously. Using the time slider tool, the pilot can select different advances in time to view the respective weather polygons on the display, with a circular icon appearing on the TAP-generated route modification corresponding to approximately

Flight Trials

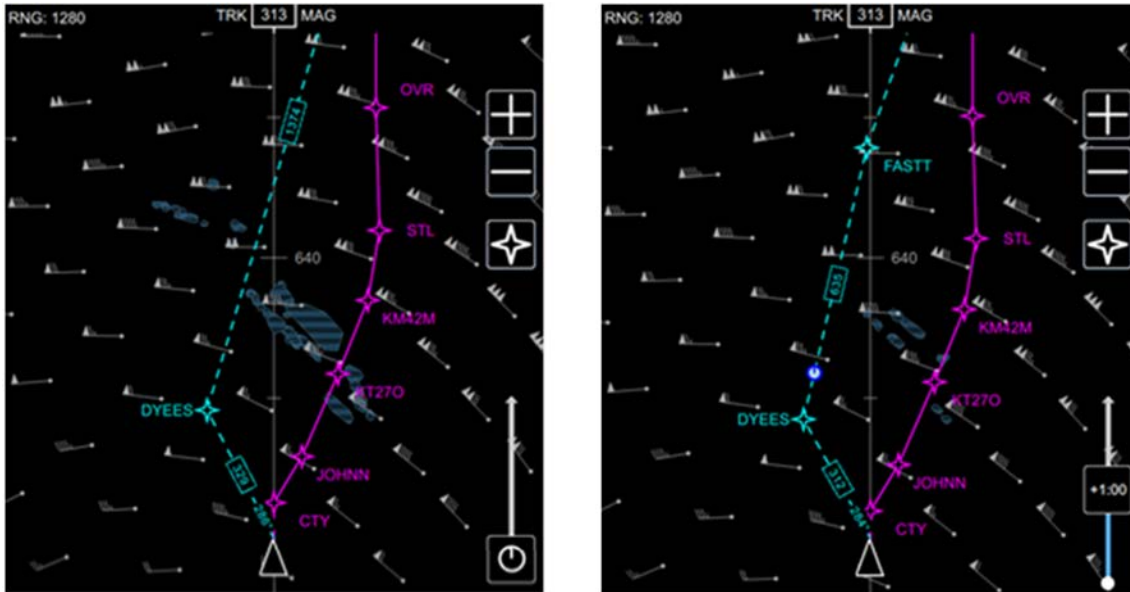

(a) TAP Display showing nowcast polygons. (b) TAP Display showing 60-minute forecast polygons.

Figure 31. TAP v15-2 map display with time slider. From ref. [45].

where the aircraft would be at that time. Figure 31(a) illustrates the time slider (square icon in bottom right of display) with the current time selected, and Figure 31(b) with one hour in the future selected. Notice the circular aircraft icon on the trajectory appears in the one hour forecast, and the avoidance polygons change location and size based on that particular forecast.

11.3.4. Semi-Automating the TAP Cruise Altitude and Speed Settings

The final accomplishment of FT-3 testing noted in this report is unrelated to weather data but highlights the general utility that NASA flight testing provided in identifying and resolving TAP implementation issues relevant to the airline operational evaluation. This case study, documented in reference [55], examined the design and development of algorithms to track and automatically set the cruise altitude and cruise speed parameters in the TAP Display (see Figure 25, p96). These parameters are used by TAP TG to predict the current trajectory and compute route modification solutions. The values typically change in flight but would not be automatically available to the TAP software via the ARINC 834 STAP feed in the Alaska Airlines implementation. Therefore, the flight crew would have to manually update the cruise altitude and cruise speed settings on the TAP Display anytime those parameters changed. Incorrect settings for either cruise altitude or cruise speed lead to inaccurate predictions of fuel and time outcomes, thus causing inaccurate and imprecise optimization solutions. Furthermore, feedback from Alaska Airlines tech pilots during flight-testing on the HU-25A indicated the pilot's workload due to maintaining the TAP cruise altitude and speed settings would be unacceptable in an operational evaluation.

To address these concerns, two algorithms were designed, implemented, and tested to allow the TAP Display to automatically track, infer, and set the cruise parameters – one for the cruise altitude and one for the cruise speed – based on the pilot's initial settings of these parameters and the aircraft behavior as sensed through aircraft state data. Each of these algorithms operate in a continuous loop once the aircraft is above a configurable altitude.

Flight Trials

Initial laboratory tests were structured to identify gaps in the logic and set baseline parameters used to tune the algorithms. Subsequent testing in the HU-25A centered on identifying operational issues with the implementation of the logic, such as precision errors in cruise setting calculations or undesired trends during aircraft maneuvers. In one example occurring during the climb to the initial cruise altitude, a logic error in the automation inadvertently caused the cruise altitude setting in the TAP software to descend from the user initial setting in 1000-foot increments until it matched the aircraft's barometric altitude while it was still climbing. This undesired behavior also manifested during step climbs or descents at cruise altitude, especially if the altitude change was greater than 4,000 feet. The logic was modified to prevent the algorithm from changing the cruise altitude setting in cases where the barometric altitude was converging towards the target cruise altitude.

During a subsequent flight on the HU-25A, a second logic gap was identified in the updated version of the cruise altitude algorithm. On that particular flight, the aircraft was instructed to level off after takeoff at 4,000 feet for approximately 3 minutes before climbing to the desired cruise altitude of FL300. Due to the duration of the intermediate level off, the cruise altitude algorithm correctly inferred that the aircraft was in a steady-state error condition (i.e., the cruise altitude setting in TAP was FL300 while the aircraft was steady and level at 4,000 feet) and modified the cruise altitude setting in TAP accordingly to 4,000 feet. The algorithm performed as designed; however, from an operational perspective, the behavior was not desired. The logic was modified to include a check to determine if the barometric altitude of the aircraft was greater than a configurable minimum cruise altitude parameter before the algorithms would begin to operate. The altitude parameter was set to FL300 for the Alaska Airlines operational evaluation.

After the final version of the cruise altitude and cruise speed algorithms were implemented and tested, they were delivered to Alaska Airlines. The tech pilots who initially raised a concern regarding a potential increase to the pilot's workload due to the manual entry of the cruise settings in TAP were able to exercise the revised software during the Alaska Airlines operational evaluation. They provided positive feedback that the new functionality was acceptable and corrected the deficiency; that is, the correct cruise settings only had to be set once which resolved the workload concern and reduced a potential source of pilot error. In addition to correcting the deficiency, the tech pilots felt the revised algorithm increased confidence in the calculated fuel and time savings since the trajectory predictions now used the correct aircraft cruise altitude and speed values.

12. Operational Evaluation

The capstone activity of the NASA TASAR project was an operational evaluation in airline revenue service. Completing such a visible evaluation was essential for TASAR to fulfill its near-term goal of transferring technology to industry to enhance flight efficiency for today's airspace users, while also laying the groundwork for its long-term goal of enabling operational autonomy for future airspace users. The outreach activities described in Chapter 8 were highly effective at generating significant community awareness and interest in TASAR. However, getting the industry to actually adopt TASAR requires breaking down significant barriers. NASA needed to eliminate risks to airlines and industry by proving the technology could indeed be deployed in an airline operational environment and that it produces sufficient cost savings to warrant the expense of its adoption. As a consequence, NASA itself incurred risks because no guarantee existed at the outset that the technology deployment would succeed or that sufficient cost savings would be demonstrated. However these risks were substantially mitigated by the broad-based risk-reduction Research and Development (R&D) activities described throughout this report and communicated to the community in conference publications in 2013, "Developing an Onboard Traffic-Aware Flight Optimization Capability for Near-Term Low-Cost Implementation" [57], and in 2015, "Achieving TASAR Operational Readiness" [58]. Indeed, these publications gave evidence that NASA did its homework in preparing TASAR for industry adoption.

Conducting an airline operational evaluation required securing a partner airline. As described in Chapter 8, community outreach activities successfully generated interest in TASAR at multiple airlines. Among these activities, airlines were invited to participate in the first TASAR flight trial, giving them first-hand experience with the prototype technology in a live flight environment. Several airlines left the flight trial with concrete interest in TASAR, but two responded affirmatively to NASA's proposal to conduct an operational evaluation. Subsequently in 2015, NASA executed SAAs with the two airlines, Virgin America and Alaska Airlines, to conduct the evaluations using their commercial transport aircraft. These were non-reimbursable agreements, meaning no funds would be exchanged, and each side would fund their side of the partnership. This by itself was a significant accomplishment. For two airlines to decide to invest their scarce discretionary resources in an operational evaluation of new NASA technology signified the technology's true relevance in the industry and their confidence in NASA to deliver as a partner. And from NASA's perspective, a self-funded partnership eclipses a contract relationship as a measure of strategic engagement with industry in accomplishing NASA's mission of technology transfer. For TASAR to generate *two* such self-funded partnerships clearly underscored that this NASA innovation was achieving the coveted industry "pull" needed to achieve NASA's mission of technology transfer.

12.1. NASA and Partner Airline Objectives

As stated above, NASA sought to eliminate risks and barriers for airlines and commercial vendors to widely adopt TASAR technology. Since no new industry standards were required to implement TASAR, proving the technology in actual airline operations stood out as the most effective means of establishing its viability in a significant aviation market. Having these two airlines volunteer for the activity was particularly fortuitous. Virgin America exclusively operated the Airbus A320 family of aircraft, while Alaska Airlines exclusively operated the Boeing 737

Operational Evaluation

family. Together, these aircraft types dominate the single-aisle commercial transport category of aircraft in the U.S. and much of the world. Furthermore, the two airlines also employed different EFB architectures. Virgin America was in the process of upgrading to the Astronautics Nexus™ Class 3 EFB, representing a consolidated architecture, whereas Alaska Airlines had standardized on the iPad and would connect it as a Class 2 EFB in a distributed architecture. Working with both airlines would enable NASA to solve implementation issues of both aircraft types and both EFB architectures, thereby reducing adoption risks even further for the industry.

In addition to working through the technical issues, NASA also had the objective of validating the estimated cost-saving benefits of TASAR. Chapter 5 summarized the method and findings of a benefits estimation analysis that was conducted using a representative model of TASAR in a simulation environment. It was these estimates, performed specifically for the partner airlines, that the airlines used to gain internal financial approval to partner with NASA to conduct the operational evaluations. The estimated savings for each airline was the same: about \$5 million per year. It would be up to the airlines to determine whether the savings were sufficient to build a fleet-wide business case, but it was up to NASA to validate the savings potential of TASAR. An operational evaluation would provide that opportunity.

For the two airlines, the primary objectives of the partnerships were straightforward: evaluate TASAR through a limited trial, assess its utility in normal operations, and acquire sufficient evidence of cost savings to build a business case to equip their entire fleets. This represents the normal method for airlines to evaluate new technologies, though they are highly selective of the technologies they evaluate given the high cost and limited discretionary budget typically available. In the case of TASAR, both airlines also recognized its game-changing potential and long-term benefits achievable by expanding its functionality and integrating it with existing and emerging technologies. Both airlines had well-established reputations as technology-centric airlines, especially Alaska Airlines who pioneered Required Navigation Performance (RNP) approaches and was the first major domestic airline to use the iPad to replace paper manuals. Seeing the potential of TASAR to truly revolutionize aircraft operations, Alaska Airlines wanted to lead the industry here as well, not only by being first but by encouraging the rest of the industry to follow. To that end, they spoke publically on many occasions through industry forums and press releases about TASAR, about their ongoing evaluation, and about the future they saw for the technology.

12.2. Airline Merger

Since Alaska Airlines was ready prior to Virgin America, its operational evaluation was the first focus for NASA. The kickoff meeting for Alaska Airlines was held September 22, 2015, and the corresponding meeting for Virgin America was held June 9, 2016. Subsequently Alaska Airlines announced it would acquire Virgin America in a merger. Shareholders approved the merger in July 2016, and the merger was completed in December 2016. Alaska Airlines confirmed it would only have resources to conduct the TASAR evaluation on one of their two fleets. Fortunately, NASA and Virgin America had expended only limited effort by this point on plans for implementation on the A320. Given the significant progress already made on the Boeing 737 implementation, it was mutually agreed to terminate the Virgin America SAA and A320 evaluation plans. The decision was also influenced by NASA ATD Project's change in priorities toward air/ground integration.

Operational Evaluation

12.3. Approach

The plan for the Alaska Airlines operational evaluation would be to conduct TASAR operations on several aircraft in revenue service for a data collection period of approximately one year. This duration was deemed necessary to collect sufficient data for statistical analysis and to capture seasonal variations in winds and weather. The approach as executed is summarized in the remaining sections, including the areas of government/industry teaming, aircraft equipage, system testing, TAP Operator training, flight conduct, and data analysis. Further details of the approach are provided in references [59]–[61].

12.4. Building the Government/Industry Team

Achieving the first operational TASAR flight on Alaska Airlines aircraft required an extensive, multi-disciplinary collaboration. Organizations and individuals contributing to this achievement included:

- NASA research, legal, licensing, software release, and airworthiness review offices
- NASA-contracted software developers, testers, and analysts
- Industry hardware, software, and certification specialists
- Government regulatory organizations
- Airline departments including flight operations, avionics engineering, aircraft maintenance, cabin systems engineering, mobile technology, crew training, regulatory compliance management, and flight dispatch

The extensive coordination required to ensure all disciplines were adequately engaged and had their requirements met in the proper sequence highlights the complexity of installing research software on a commercial aircraft. With little to no ability to modify software or hardware after installation, all elements of the project required careful planning and execution.

The SAA defined the basic objectives and responsibilities of the collaboration:

1. NASA to adapt TAP software for compatibility with Alaska Airlines' trial aircraft
2. Alaska Airlines to install EFB hardware, data connections, and TAP software
3. Alaska Airlines to acquire FAA operational approval to operate TAP software
4. Alaska Airlines to conduct evaluation flights in revenue service for up to one year
5. NASA to analyze data for operational benefits from using TAP
6. NASA to update TAP software based on interim findings

To achieve these objectives, NASA and Alaska Airlines assembled the multi-organizational team shown in Figure 32. With leadership jointly provided by NASA and Alaska Airlines TASAR project leads, the team pooled together a diverse set of expertise. NASA researchers and contractors contributed expertise in the TAP software code and its capabilities, adapting it to new aircraft environments, software testing, and data analysis to confirm proper operation and realized benefits. Alaska Airlines Avionics Engineering contributed expertise in hardware integration, software loading, and avionics regulatory compliance management.

NASA supporting organizations contributed expertise in systems engineering, legal agreements, software release processes, and Agency-required reviews and approvals (e.g., Institutional Review Board, Airworthiness and Safety Review Board). Alaska Airlines internal organizations contributed expertise in flight dispatch, mobile information technology (IT), flight operations regulatory compliance management, aircraft performance, fuel efficiency, and crew training.

Operational Evaluation

Alaska Airlines arranged for three leading aircraft system suppliers to contribute to the project. UTAS (later Collins Aerospace), Gogo, and ACSS each contributed expertise in their hardware platforms, software integration and testing, software quality assurance and packaging, IT integration and security, and aircraft and technology certification. Each of these industry partners played a crucial role in the success of the project, working cooperatively with each other and the NASA/Alaska Airlines teams through frequent meetings and periodic integration testing in laboratories and onboard the aircraft.

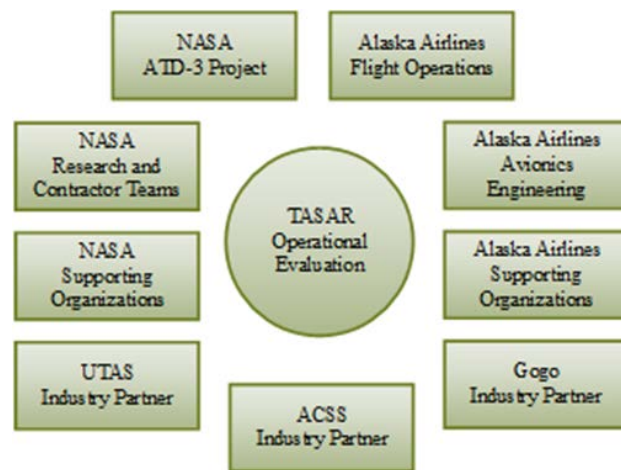

Figure 32. Multi-organizational team for the TASAR operational evaluation. From ref. [60].

12.5. Equipping the TASAR Fleet

While 10 aircraft were initially proposed to maximize the collection of benefits data, Alaska Airlines leadership approved three aircraft to conduct the evaluation. All three aircraft would be Boeing 737-900ER, the aircraft type typically used on transcontinental flights where the largest TASAR benefits were expected, and all three would be new deliveries from Boeing.ⁱ

To achieve full TASAR capability, the three aircraft underwent the following system modifications, shown in Figure 33:

- Installation of one UTAS AID2 and two UTAS TIMs with connectivity to two iPads
- Connectivity of UTAS AID2 to Gogo Airborne Control Processing Unit (ACPU2)
- Upgrade of ACSS TCAS 3000SP to ADS-B In with auxiliary DTIF output, and subsequent connectivity to the UTAS AID2
- Installation of TAP software on the AID2, ACPU2, TIMs, and iPadsⁱⁱ

To reduce project risk, a system architecture was designed wherein two instances of TAP were installed on each aircraft, one for the Captain (or left seat) and one for the First Officer (or right seat), though either system could be operated from either seat. The Captain's TAP Engine would run on the Gogo ACPU2, and the First Officer's TAP Engine would run on the UTAS AID2. This approach reduced the risk that one or the other processor would be insufficient for running TAP, though both proved to be sufficient. Based on recommendations from FT-2, generally only one TAP would be operated on a given flight.

12.6. Adapting TAP for the Alaska Airlines B737-900ER

Adapting TAP to a particular aircraft requires several things to be addressed: (1) mapping TAP's inputs to the appropriate data sources of the onboard avionics and internet sites, (2) installing aircraft performance data from which TAP can model the aircraft behavior for accurate trajectory

ⁱ The Alaska Airlines TASAR fleet for the operational evaluation were aircraft N267AK, N270AK, and N272AK, delivered in January, March, and April of 2017, respectively.

ⁱⁱ iPads are portable equipment and not considered installed hardware on the aircraft. Installation of the TAP Display app on the iPads was managed by Alaska Airlines Flight Operations, whereas the remaining TAP component installations on installed hardware were managed by UTAS, Gogo, and Alaska Airlines Avionics Engineering.

Operational Evaluation

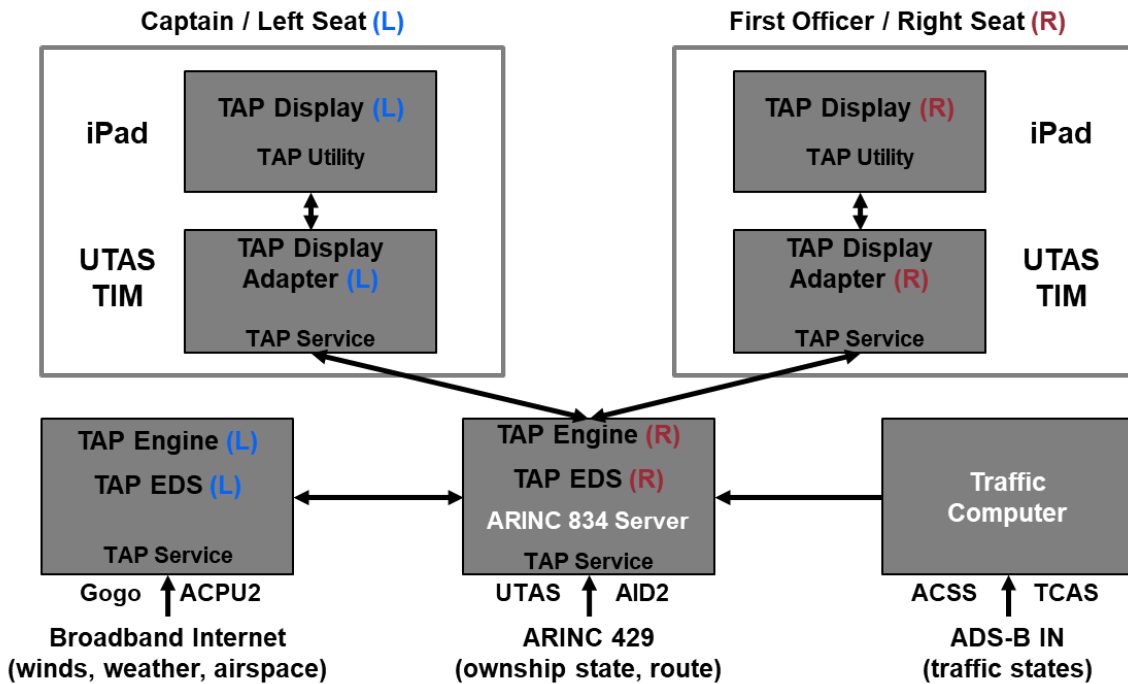

Figure 33. System architecture for the Alaska Airlines operational evaluation. From ref. [60].

prediction, and (3) verifying or adapting the hosting hardware to support the TAP software application (e.g., operating system, processor speed, memory footprint, partitioning). Since none of these adaptations are standard for all aircraft, each installation of TAP in a new aircraft environment requires some level of adaptation to that environment and/or by that environment. For the Alaska Airlines deployment, UTAS, Gogo, and the NASA team worked together to adapt TAP and the hosting hardware for mutual compatibility, enabling TAP to compile, run, support inter-process communications, and be protected on the hardware. In addition, the NASA team devised a new “TAP Services” architecture to facilitate installation and remote execution of TAP software components on otherwise inaccessible devices onboard the airliner.

12.6.1. Avionics Data Mapping

TAP’s primary sources of input data are onboard avionics, from which TAP derives the current state of the aircraft (e.g., position, heading, altitude, speed, weight). The AID2 was wired to ARINC 429 output busses of appropriate avionics systems, allowing it to provide the avionics data to TAP via an ARINC 834 server in STAP format. TAP uses these data to monitor the aircraft’s autoflight system settings, to model the aircraft’s state, and to predict future 4D positions and fuel states along the FMS active route and TAP-generated candidate reroutes. Alaska Airlines’ B737-900ER aircraft hosted a GE Aviation FMS that provided multiple ARINC 429 output busses containing much of the data TAP required.

TAP contains an avionics data map that identifies which data elements are available on which port and from which “equipment code” (i.e., avionics device). The mapping can differ from one aircraft implementation to the next, but within a given aircraft-type fleet at an airline, the mapping is typically the same for all the aircraft of that fleet. This was the case for Alaska Airlines’ three

Operational Evaluation

B737-900ER aircraft assigned to the trial, and so the same TAP software configuration was installed on all three aircraft, greatly simplifying configuration management for Alaska Airlines Avionics Engineering. At the time of TAP software deployment for this project, TAP was capable of reading data only in ARINC 429 format, but subsequently the capability of reading ARINC 717 data formats was added, increasing the availability of data for future adaptations via the aircraft's digital flight data acquisition unit.

A challenge identified during an on-aircraft test at Alaska Airlines' maintenance facility at KSEA was that the wiring design did not include connecting the AID2 to the Air Data Computer (ADC) as intended. The ADC was expected to provide certain key data parameters to TAP, including altitude, Mach, calibrated airspeed, true airspeed, altitude rate, and static air temperature. Four of the parameters were fortunately available on existing FMS output busses to which the AID2 was wired. TAP's data mapping was therefore modified to acquire these parameters from the FMS rather than the ADC. Unfortunately, Mach and true airspeed were not available as dedicated parameters on an available FMS or alternate bus. However, the NASA team established the feasibility of computing these parameters dynamically using equations for compressible, isentropic flow. To avoid the expenses of modified wiring and certification, the computations were implemented in TAP and verified on subsequent tests.

12.6.2. Aircraft Performance Modeling

The TAP TG algorithm [44] predicts future 4D positions and fuel states along the FMS active route and TAP-generated candidate reroutes. The versatile TAP TG has been demonstrated to support various aircraft types (e., turbojet, turboprop) using aircraft performance models (APM) at various levels of detail and in various formats. For the Alaska Airlines implementation, the expectation was for TAP to use the APM dataset provided by the Original Equipment Manufacturer (OEM) of the aircraft, in this case Boeing, using the SCAP industry standard format. Unfortunately, it was not possible to proceed on this path for two reasons. First, the SCAP standard is used by OEMs primarily for takeoff and landing data, and en route cruise performance modeling has not kept up with this standard in the industry. Second, the APM data usage agreement between NASA and Boeing was not completed in time for the project, though it was eventually executed. An alternative APM approach was therefore pursued and implemented using the Eurocontrol BADA 4 aircraft performance modeling specification and dataset. BADA 4 enables aircraft behavior to be modeled with increased levels of precision over the entire flight envelope. A NASA agreement with Eurocontrol, with concurrence received from the OEM, authorized NASA to implement the BADA 4 specification in TAP and deploy it with the Boeing 737-900ER BADA 4 dataset to Alaska Airlines for the TASAR operational evaluation. This deployment was the first approved use of BADA 4 in an airborne application.

One element lacking from the BADA 4 APM was a specification of economy (ECON) cruise speeds (i.e., the FMS speed schedule when the pilot has selected the ECON setting for FMS speed management). Airborne applications like TAP are dependent on accurate speed modeling for the particular aircraft. To compensate for the missing ECON speed data, an Alaska Airlines B737-900ER flight simulator was used to derive a speed table that included dependencies on appropriate flight parameters. TAP TG was modified to read the speed table. This limitation of BADA 4 was communicated back to the Eurocontrol BADA team to help improve the model going forward.

Operational Evaluation

12.6.3. Service Architecture

To facilitate installation and execution in a commercial airline environment, NASA implemented some significant enhancements to the TAP software architecture [59]. For instance, one major challenge of airline environments is the relative inaccessibility of installed hardware, which affects installing the software, launching it, and retrieving data. Therefore, installation packages and tools were implemented to allow aircraft maintenance crews to install the TAP application suite with a minimum of effort. The installation packages are customized for each aircraft, including the binary executables, configuration files, aircraft performance data, network addresses, and target host locations.

A TAP Service daemon was installed on each computing platform hosting one or more TAP components. The TAP Services launch the various remote TAP components when triggered to do so by the pilot launching the TAP Display application on the iPad. At the conclusion of the flight, the TAP Service is responsible for compressing and offloading output data from all TAP components to a central repository (one for each TAP) for offline retrieval and evaluation. UTAS, Gogo, and NASA developed scripts and file naming structures that automated the entire data retrieval process after each flight and allowed any dispersed data files to be reunited later.

A TAP Utility iPad application was developed for use in validating the completed installation across the multiple hardware hosts. The TAP Utility communicates with the TAP Service daemons to validate the installation. If there is a problem, the TAP Utility provides troubleshooting information to the user as to which components have failed to install.

12.6.4. Host Hardware Testing

TAP software components were distributed across multiple specialized hardware devices on the Alaska Airlines aircraft: AID2, ACPU2, and TIM (in addition to the commonly available iPad). Of these three devices, only the TIM could be acquired by NASA for bench testing. Testing of TAP on the AID2 and ACPU2 could only be performed by UTAS and Gogo in their test facilities. Unique hardware configurations were needed to compile and host the software on each device, which could only be performed by UTAS and Gogo engineers. The NASA team worked closely with the UTAS and Gogo teams in their bench testing of TAP and helped to assess performance acceptability. One test outcome was confirmation that TAP could be successfully hosted on a wide range of computing platforms with significantly differing performance characteristics. However it also reinforced the decision stemming from FT-2 that only one instance of TAP be operating in the cockpit at a time. Performance differences between TAP instances running on different hardware platforms would only exacerbate the factors identified in FT-2 that complicated crew coordination.

In addition to bench testing of TAP on individual hardware devices, integrated testing was performed to verify TAP functionality across the internal network (particularly between the UTAS AID2 and Gogo ACPU2). Multiple test environments were employed, including co-located testing at one facility, remote testing through connected facilities, and on-aircraft testing once the hardware was installed. This final test environment used the actual flight hardware and aircraft network, but the limiting factor was the small amount of testing time available since the aircraft could not be pulled out of service. Tests were performed at KSEA on overnight stops.

Operational Evaluation

12.7. Authorizing the TASAR Installation

The entire implementation of TASAR on the three Alaska Airlines aircraft was fully FAA-approved through normal, established authorization processes. The hardware installations and upgrades were approved through three STCs and a Technical Standard Order (TSO). The TAP software installations used rigorous industry processes at UTAS and Gogo for software packaging, verification, and tracking. TAP operational use was approved and documented in Alaska Airlines OpSpec A061, “Use of Electronic Flight Bag.” These various installations, certifications, and operational approvals were extensive, intricate, and time-consuming processes and were dominant factors in the ever-expanding schedule of achieving readiness for conducting the operational evaluation. However they were largely driven by Alaska Airlines, the FAA, and the participating industry collaborators (UTAS, Gogo, and ACSS), and being standard industry practices tangential to TASAR, they are not described further in this report. Some additional information is provided in reference [60].

The key outcome of the application of these processes was that Alaska Airlines was fully authorized by the FAA to conduct TASAR operations on revenue service flights with passengers in the aircraft, as if it were a commercially deployed system. Figure 34 shows the first commercial airline aircraft to be TASAR equipped.



Figure 34. First of three Alaska Airlines aircraft to be equipped for TASAR. *Photo by author.*

12.8. Verifying the Installed TASAR System

The long lead time required for TAP software packaging by UTAS and Gogo made it imperative to verify the Alaska Airlines TASAR system as early as possible to detect and resolve any faults with minimum delay to the project. Prior to aircraft delivery, preliminary component integration tests were performed by UTAS and Gogo at their facilities, verifying that TAP ran correctly on their hardware and that the secure network link established between the AID2 and ACPU2 supported all required TAP-related messaging. However, verifying the installed system required access to the flight hardware and installed network, which only became available in phases as the various certification processes ensued following the first aircraft delivery in January 2017. To this end and to reduce project risk, the NASA team devised a multi-stage test plan that ran in parallel with the phased aircraft implementation of TASAR equipage and certification. Through a series of on-aircraft ground and airborne tests performed in concert with evolving certification/approval

Operational Evaluation

phases, the tests would, in turn, verify the required data inputs, ensure proper software performance on the flight hardware and networks, and methodically build toward overall operational readiness. The plan consisted of four incremental “stages,” numbered Stages 0 through 3, with Stages 0 and 1 being developmental, Stage 2 being both developmental and operational, and Stage 3 being operational.

12.8.1. Stage 0

The Objective of Stage 0 was to verify that every TAP input parameter (e.g., present position latitude) mapped correctly to the appropriate avionics data source, that each data parameter was indeed received (with expected characteristics like data rate), and that TAP properly decoded each one. Given that the software team developed the mapping and decoding scheme based on documentation, the risk to be averted was any difference between the documentation and the installed hardware. The initial installation of the AID2 for certification testing in the newly delivered aircraft presented the earliest opportunity to conduct this test.

During Stage 0 testing, Alaska Airlines and NASA technical staff ran TAP on a laptop computer connected to a UTAS TIM onboard the aircraft. A laptop was used to host TAP because Stage 0 preceded operational approval to install TAP on the AID2 and ACPU2. Instead of processing the avionics data, TAP recorded STAP messages from the AID2 to a binary file. During data collection, a separate process monitored this binary file to confirm that all required Stage 0 data had been successfully received and decoded.

Stage 0 was executed in three parts: Stage 0 Hangar, Stage 0 Taxi, and Stage 0 Airborne. During Stage 0 Hangar, Alaska Airlines personnel used a ground-test apparatus to apply controlled signals to aircraft sensors to make certain avionics generate non-zero data as if the aircraft was airborne, a process that worked for generating most of the avionics data. However, the FMS required the aircraft to be moving above 40 knots before complete active route waypoint information was generated. Alaska Airlines pilots conducted a high-speed taxi on Seattle–Tacoma International Airport (KSEA) runway 34C, during which the route waypoint data were collected. The Stage 0 Taxi operation was made possible through coordination with FAA controllers in KSEA Tower. Additional parameters such as guidance mode were only available in flight, and so a single Stage 0 Airborne data collection was included on a non-revenue repositioning flight. Once the ADS-B system was installed, another Stage 0 Hangar data collection was used to collect and verify ADS-B data.

Findings of Stage 0 analyses are presented in reference [60]. They indicated that the majority of expected parameters were properly received, and that data rates were acceptable. The exception was the absence of the six critical air data parameters due to the ADC not being wired to the AID2. As described earlier, the issue was addressed by using alternative sources for some of the parameters and computing the others in TAP.

12.8.2. Stage 1

The objective of Stage 1 was to verify that TAP performed properly in flight prior to Alaska Airlines pilots actually using the software. Conducted as a “shadow” test, a TAP mode was developed where it would run automatically without a pilot’s user interface (i.e., the TAP Display). Stage 1 was critical to achieving operational readiness and had several key accomplishments. Stage 1 testing confirmed Stage 0 findings with in-flight data that TAP correctly processed the data it received from avionics and internet sources. It confirmed that TAP computed reasonable and stable

Operational Evaluation

route modifications suitable for operational use. It also confirmed that TAP produced accurate estimates of time/fuel savings. Stage 1 testing also assessed TAP's processing performance when running in the actual flight hardware environment.

Stage 1 data were collected on revenue service flights of the three TAP-equipped aircraft. Alaska Airlines pilots on these aircraft were asked to launch the TAP Utility application installed on their iPads to initiate the data collection. Deploying TAP Utility to all Alaska Airlines pilots, rather than just a select few, enabled data collection for a wide range of destination airports and flight conditions. TAP Utility required minimal data entry by the pilots and launched TAP (without the TAP Display) using a "fire and forget" procedure such that TAP operated without pilot interaction or observation for the duration of the flight, just recording data for later analysis. Pilots were asked, but not required, to launch the utility either at the gate or during flight. All data were recorded on UTAS and Gogo hardware and transferred off manually, later automatically via internet downloads, after multiple flights were completed.

The certification and deployment schedule necessitated that Stage 1 be subdivided into Stage 1a and 1b, the difference being AID2-ACPU2 connectivity in flight and therefore TAP's access to in-flight internet. TAP requires internet connectivity to receive wind data, needed to calculate candidate route modifications. In Stage 1a, internet connectivity was not yet available. If pilots launched TAP Utility on the ground, then TAP received internet data (including winds) via a terrestrial modem and proceeded to work properly during the flight. If pilots launched it in the air, then TAP did not receive internet data and no route modifications were generated during the flight. However, a separate EDS process running concurrently at NASA recorded internet data that was incorporated in post-flight runs using TAP's "playback" capability to generate the required data for analysis. During the second part of Stage 1, referred to as Stage 1b, internet connectivity was available throughout the flight to TAP, thereby allowing direct post-flight analysis of the data.

Stage 1 flights began September 26, 2017. Findings of Stage 1 analyses are presented in reference [60]. They confirmed that TAP received and correctly processed the necessary avionics and internet data, performed acceptably well on the flight hardware, produced stable and reasonable route modification solutions, and predicted time and fuel burn with approximately the same accuracy as the FMS and airline flight planning system. Certain air data parameters from the FMS, substituting for the (unwired) ADC, were found to be noisier than previously experienced in flight testing and triggered undesired behaviors in TAP. TAP software changes were made and positively confirmed using the TAP playback capability that replayed the recorded avionics data into the updated software. This capability to verify fixes offline proved invaluable in that it enabled NASA to deliver a single TAP software package update to UTAS and Gogo for each Stage with high confidence that the update resolves all identified issues in the previous Stage. Given the software deployment time (measured in months), this process was an absolute necessity for schedule integrity.

12.8.3. Stage 2

Stage 2 represented both the final developmental stage and first operational stage of the evaluation. It was the first opportunity to test the end-to-end TASAR system, including the final hardware (iPads and TIMs) and software (TAP Display and TAP Display Adaptor), that could not be included in the Stage 1 "shadow" testing. As a developmental activity, Stage 2 would identify and correct any remaining identified TASAR system faults. In both its developmental and operational roles, Stage 2 flights required TAP Operators and was therefore conducted with a

Operational Evaluation

limited group of tech pilots from Alaska Airlines Flight Operations. To the extent the complete TASAR system was working properly, the Alaska Airlines tech pilots would use TAP as an operational advisory tool to optimize their flights, and the resulting data would contribute to the analysis of TASAR benefits.

The use of TAP Operators in Stage 2 (and Stage 3) required augmentation in order to accelerate the collection of data while minimizing cost. The accelerated data collection was necessary to accommodate an unexpected reduction in the NASA project budget in 2018 and 2019 that would curtail the duration of the operational evaluation, originally planned for one year. Consequently, Alaska Airlines Flight Operations augmented their pool of four tech pilots as TAP Operators with four student interns (three for Stage 2 and one for Stage 3). In addition, two NASA researchers were included in the pool of TAP Operators. The interns (flight-trained, aspiring airline pilots) and NASA researchers operated TAP from the jump seat (Figure 35) and coordinated with the regular flight crews on route modification advisories from TAP. The Alaska Airlines tech pilots operated TAP either from the front seats when performing as a flight crew member or from the jump seat when not. When the Alaska Airlines tech pilots operated TAP as a flight crew member, these were actual TASAR flights where TAP was used as designed and intended as a hands-on flight crew decision aid.



Figure 35. NASA researcher operating TAP from the jump seat. Photo by K. Burke.

Stage 2 spanned two months between July and September 2018. It included 70 attempted TAP flights, 59 of which included successful TAP operations. However, technical issues associated with the aircraft network (on which TAP relies) affected TAP operations on three quarters of the Stage 2 flights, resulting in either TAP not receiving required external data or protectively shutting down as a result of network instability. The issues were not observable in Stage 1 due to the absence of the TAP Display and the inability to confirm on which flights the TAP Utility was used to launch Stage 1 attempts. The discovery of these latent issues validated the developmental role of Stage 2 in the overall system verification plan.

As the issues were observed and diagnosed, immediate procedural mitigations were implemented to limit the impact on continued Stage 2 data collection. Network testing at UTAS and Gogo facilities ensued to identify potential causes with only limited success. While insufficient time was available to implement TAP structural changes to increase resiliency to network instabilities (due to the lead time required to deploy TAP on the AID2 and ACPU2), it was possible to add protections into the TAP Display software to inhibit some known triggers of TAP shutting down. This update, deployed as an iPad app directly to Alaska Airlines (needing no lead time), and paired with the procedural mitigations, provided sufficient improvement to complete the operational evaluation in Stage 3.

12.8.4. Stage 3

Stage 3 was the final operational stage of the evaluation. It was originally intended that Stage 3 would expand the evaluation to a larger pilot population and use an updated version of TAP to

Operational Evaluation

address any significant issues identified in Stage 2. The plan called for training a large number of Alaska Airlines line pilots using training materials developed by NASA, including NASA's TAP CBT integrated into the airline's Learning Management System. However, given the shortened window to complete the evaluation due to NASA's budget reduction and the expense of training large numbers of pilots for a limited trial on only three aircraft, it was decided to conduct Stage 3 flights with the same TAP Operator approach used in Stage 2.

Stage 3 was conducted in a three-month period between January and April 2019, adding an additional 49 flights for a total of 119 flight attempts between Stage 2 and Stage 3. Of these, 90 flights were deemed valid for a quantitative benefits analysis (see Section 12.11, p119). Of the 90 flights, 22 were performed with Alaska Airlines pilots operating TAP from the front seat as flight crew members, in other words, true TASAR flights.

12.9. Training TAP Operators

To reach TASAR operational readiness, it was equally important to train pilots for the operation as it was to equip the aircraft. To a pilot, TASAR is simply another procedure to learn, one that involves the use of technology, cross-checking with other information sources, and decision making to achieve an objective. Proper training helps ensure this process achieves its full potential. Because two primary purposes of the operational evaluation were to assess TAP's utility in flight operations and to quantify the achieved benefits in cost savings, the desired approach was to engage a large number of Alaska Airlines' line pilots in the evaluation, give them high-quality training on TAP, and encourage its use on every flight. However as stated earlier, a significantly reduced project timeline led to a different approach, specifically the idea of using TAP Operators who may or may not be the pilots flying the aircraft. While this increased the rate of data collection, it also partially removed a key element of the evaluation which was the immersion of TAP in the decision-making of the flight crew. On many flights, TAP would not be within the field of view of the flight crew, nor would the flight crew be trained on its capabilities and proper use. Instead, TAP on these flights would be at the jump seat station behind the flight crew, being operated by a person who is not a member of the crew, not an airline pilot (in most cases), and possibly far junior to the flight crew. As a result, the ability to assess utility would be impacted, and the benefits (cost savings) achieved would likely be a conservative estimate of what would be achievable with TAP used by the flight crew as intended. This only increased the importance of giving effective training to these TAP Operators to minimize these effects.

To train the Alaska Airlines tech pilots and interns in the role of TAP Operator, NASA researchers developed a training curriculum conducted onsite at the Alaska Airlines Flight Operations Training Center. Read-ahead materials included the TAP Operating Procedures Handbook and TAP Flight Manual Bulletin. Briefings included background on TASAR, an overview of the operational evaluation plan, a description of TAP functionality, a live interactive TAP demonstration using the "playback" capability, and a detailed review of TAP Operator checklists. These laminated checklists covered all aspects of TASAR procedures including pre-flight preparations, TAP startup, in-flight TAP settings, reroute evaluations and ATC requests, pre-descent and post-flight actions, and troubleshooting. The classroom training concluded with each TAP Operator completing the TAP CBT on tablet computers.

TAP Operator training for the interns continued in the Alaska Airlines 737-900ER flight simulator (Figure 36). Since TAP was not electronically integrated into the flight simulator, a flight plan was entered into the simulator to approximate the route in a TAP playback file generated from

Operational Evaluation

a Stage 1 flight. As the flight progressed in the flight simulator and TAP playback, a walk-through of the checklist and procedures was performed in order to familiarize the interns with using TAP and offering recommendations to the flight crew.

Finally, the Alaska Airlines tech pilots took each intern on one or more actual flights on one of the TASAR-equipped aircraft. These flights allowed the interns to develop and practice procedures for interacting with the flight crew on TAP-recommended route modifications. The interns were at a disadvantage, not being airline pilots or familiar with the cockpit and normal procedures. These flights were intended to reduce those obstacles to some degree.



Figure 36. TAP Operator training in the Alaska Airlines flight simulator. *Photo by author.*

12.10. Conducting TAP Flights

TAP flights (Stage 2 and Stage 3 flights on which TAP Operators were using TAP to identify route optimizations and where appropriate were making TAP-inspired route modification requests to ATC) were conducted on Alaska Airlines' regularly scheduled revenue flights of the three TASAR-equipped aircraft. Flights were typically conducted in pairs consisting of an outbound and return flight on the same day. All pairs originated from either Seattle (KSEA) or Portland International Airport (KPDX).

Generally, the aircraft flight schedules were not changed to accommodate the TASAR operational evaluation. In most cases, Alaska Airlines Flight Operations scheduled TAP flights by identifying suitable destinations in the upcoming schedule and coordinating a TAP Operator to be available for those flights. On some occasions, Flight Operations coordinated with flight scheduling to schedule a TASAR-equipped aircraft for a particular route. A zone pairing approach was used in flight selection to achieve variety while emphasizing the mid-continental and transcontinental flights where possible. Figure 37 shows the zone assignments and the TAP flights (depicted as straight lines) used for the benefits analysis. Where flight swaps needed to happen for operational reasons, an attempt was made to swap the flight for another airport located within the same zone, thereby preserving the balanced flight selection.

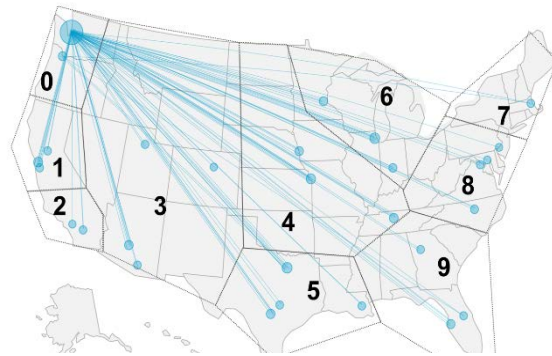

Figure 37. TAP flights used in the benefits analysis. *From ref. [61].*

For the flights with interns or NASA researchers serving as TAP Operators, an Alaska Airlines tech pilot contacted the scheduled flight crew the day before the flight to coordinate the jump seat occupant and to inform the crew about the TASAR technology being evaluated. A briefing sheet was also sent that provided background on the trial and the duties of the TAP Operator. The procedure was effective in securing cooperation from the flight crews and facilitating the TAP Operator performing their function. The interns were Alaska Airlines-badged employees which

Operational Evaluation

allowed significant flexibility in jump seating. The NASA researchers required advanced coordination and FAA approval to access the cockpit.

TAP Operators brought onboard two iPads, one for running TAP and the other reserved as a backup but otherwise used for administering surveys and taking notes. Upon boarding, the TAP Operator would connect the iPad to either UTAS TIM through Bluetooth pairing or with a custom Lightning-to-USB data cable. Checklists were followed to launch TAP to complete the TAP Startup Checklist, either on the ground or after takeoff and above 10,000 ft. The Startup Checklist was the opening screen through which the TAP Operator confirmed TAP's configuration and entered parameters for the flight. An important element was confirming the "data feeds," or TAP's connection to external data through the airborne internet connection. At a minimum, wind data were required for TAP to operate.

During the flight, the TAP Operator monitored and updated various settings on the TAP Display. Some of these settings requiring manual intervention in Stage 2 were automated for Stage 3 (e.g., the cruise altitude and speed settings). Other settings remained under manual control (e.g., the limit waypoint specifying the farthest waypoint for a route modification to rejoin the FMS active route). As the flight progressed, the TAP Operator monitored the Auto Mode solutions and engaged the flight crew where possible in assessing candidate route modifications for a potential ATC request. A "capture sheet" form implemented on the backup iPad was used to record each of these assessments by the flight crew. It allowed the TAP Operator to record notes such as crew feedback on the proposed route modification, what aircraft systems were consulted in the assessment, the crew's rationale for making or not making the ATC request, and any information on ATC's response. Details of the route modification itself did not need to be recorded here, because TAP itself was recording all such details from the avionics data.

About 30 minutes prior to descent, the TAP Operator offered a survey to the crew on their general impressions of TAP. While some crews elected to complete the survey, most did not. Near the end of the flight, TAP automatically shut itself down when reaching about 35 nmi to the destination. The automatic shutdown was used to ensure adequate recording of "as flown" state data and to ensure the data files were properly configured for automatic off-loading after landing. The TAP Operators completed the flight by entering into a "TAP Logbook" key details and notes about the flight. Once a week, the TAP Operators were asked to complete a "TAP Operator Weekly Report" in an attempt to capture their cumulative experience with TAP, though this method of knowledge collection turned out to be less than successful.

The UTAS and Gogo systems were configured to automatically offload the TAP data files after connecting to a terrestrial modem when parked at the gate. However, given the large size of the TAP data files (i.e., TAP was configured for maximum data logging) and the limited bandwidth being shared for multiple purposes, it was common for offloading to take several days to complete. Special file-naming conventions were devised and scripts written to reunite TAP data files for a particular flight well after the fact. Such were some of the complicated logistics of conducting a technology evaluation in an airline operational environment.

12.11. Analyzing the Achieved TASAR Benefits

In order to quantitatively estimate TAP benefits achieved in the operational evaluation, data were recorded by TAP during operational flights and analyzed post-flight. The method is summarized

Operational Evaluation

below. Further details are provided in references [61] and [62]. In the subsequent section, limitations of the operational evaluation and analysis method are summarized.

12.11.1. Analysis Method

TAP benefits were calculated as the cost difference between TAP-flight operating costs and baseline-flight operating costs, each of which was computed relative to their respective predicted operating costs. During TAP flights (Stages 2 and 3), TAP-computed route-modification advisories were displayed to pilots and used to make “TAP-inspired” route-modification requests to ATC. Data recorded by TAP included aircraft systems data (e.g., aircraft states and route modifications) and pilot interactions with TAP. Data on pilot interactions with TAP were used to determine whether or not a route modification observed in the aircraft systems data was due to TAP (i.e., TAP-inspired). During the period that Stage 2 and 3 flights were conducted, Stage 1 flights also continued to be flown and were used as baseline flights. Stage 1 flights had TAP running onboard but was not used by pilots or TAP Operators. During these baseline flights, TAP recorded “as flown” aircraft data and computed route-modification advisories, but the advisories were not displayed, requested to ATC, or flown. The TAP data collection on these “non-TAP flights” served as baseline flights in the benefits analysis. Every TAP flight was paired with a corresponding baseline flight of similar length that occurred as close in date as possible to the TAP flight to reduce seasonal variations.

To estimate the TAP benefit in terms of cost savings, fuel and time savings were converted to cost savings in U.S. dollars (\$). Typically, airlines use an hourly direct-operating-cost (DOC) parameter, which includes fuel cost, to convert time savings to cost savings. However, since TAP-inspired altitude changes traded off between fuel and time, the analysis separated the time-related and fuel-related components of hourly DOC. Alaska Airlines’ hourly DOC (\$1,710/hour excluding fuel) and fuel costs (\$2.28/gallon) used in this analysis were estimated from third quarter 2018 financial reports obtained from the Bureau of Transportation Statistics, a part of the Department of Transportation and the preeminent source for aviation data [63].

Eq. (3) below shows the computation of achieved TAP benefits. The first term to the right of the equal sign is the difference between flown (i.e., actual) cost (C^{flown}) and unimpeded predicted cost ($C^{predicted}$) on TAP flights. The unimpeded predicted cost is the cost that would have been incurred had the aircraft remained on the planned route. The second term in Eq. (3) similarly shows this cost difference corresponding to non-TAP baseline flights. Flown costs are incorporated into the equation because unpredictable events may occur after TAP-inspired requests that alter the TAP-predicted savings. These events may include pilot and ATC actions, as well as changing atmospheric conditions. Similarly, baseline flights are susceptible to these events that affect actual costs relative to planned costs. Accounting for these events using this method attempts to remove the influence of these events on the TAP benefits estimate.

$$TAP\ Benefit = \sum_{TAP\ flights} (C^{flown} - C^{predicted}) - \sum_{baseline\ flights} (C^{flown} - C^{predicted}) \quad (3)$$

Flown fuel and time are measured relative to fuel and time predictions generated just prior to the TAP request to reduce the impact of route and atmospheric differences prior to the point in the flight where TAP is used. Either the pre-departure flight plan or TAP could be used to compute

Operational Evaluation

the predicted cost ($C^{predicted}$), and there are advantages and disadvantages to using either prediction. Flight plans predict step climbs, but aircraft may be off their pre-departure flight plan at the time a TAP advisory is approved. TAP does not predict step climbs, but TAP predictions reflect updated route and wind information received post-departure. Both methods were used in the analysis.

Figure 38 shows the segments of TAP flights (upper diagram) and baseline flights (lower diagram) for which cost savings are calculated. For TAP flights, these segments are bounded by a TAP Start Point (TSP) and a TAP Finish Point (TFP), defined by the locations of the first approved TAP request and the last rejoin to the flight plan. For baseline flights, the segments are defined by a Baseline Start Point (BSP) at the top-of-descent and a Baseline Finish Point (BFP) positioned to produce an approximately equivalent predicted cost ($C^{predicted}$) as the corresponding TAP flight.

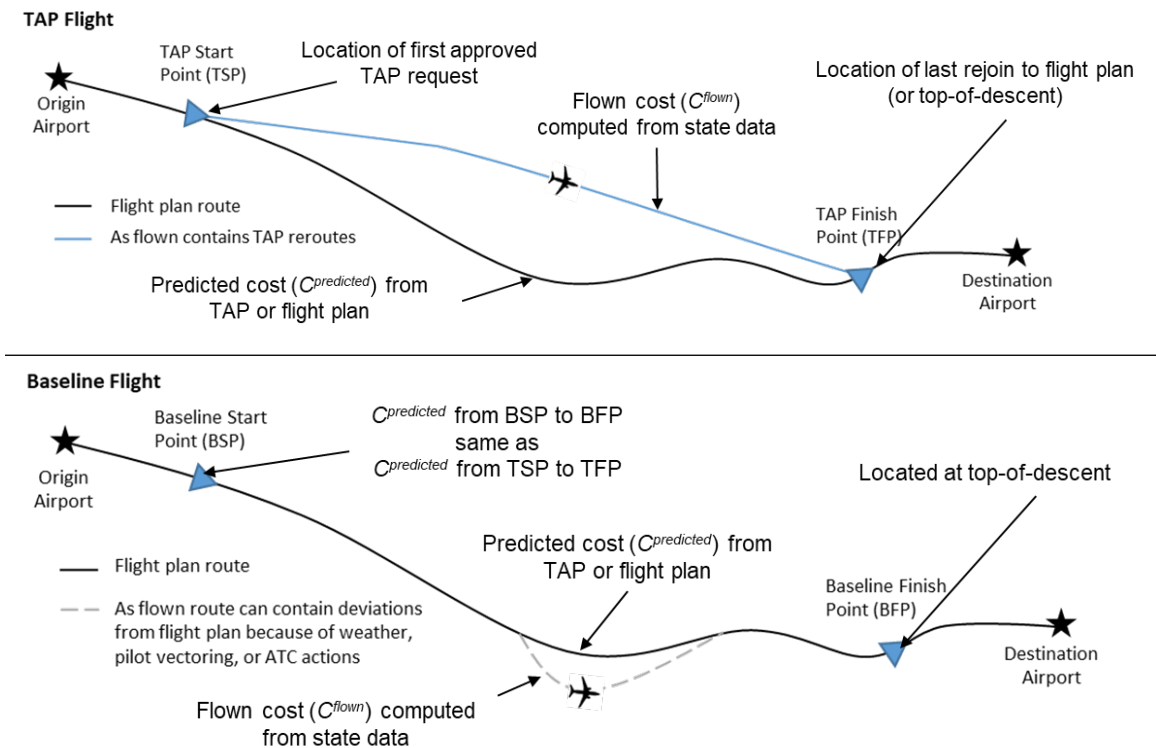

Figure 38. Calculating cost savings on TAP flights and baseline flights. From ref. [62].

TAP flights and baseline flights had to meet certain selection criteria to be included in the analysis. These criteria ensured among other things that the flight’s origin, destination, and majority of its route were in the CONUS (due to trial limitations on the waypoint database and wind data) and that TAP was sufficiently available (due to technical issues on some flights).

12.11.2. Operational Evaluation and Method Limitations

The conduct of the Alaska Airlines operational evaluation created conditions that may not be representative of TAP use in regular operations in the future. The characteristics of the benefit analysis method also had some unavoidable limitations that may affect its applicability. These and other limitations are describe in Table 15. These factors need to be taken into account when

Operational Evaluation

determining how the quantitative benefit estimates from the evaluation may relate to benefits achieved in a future deployed system. Reference [61] lists a number of related factors that may indicate that the achieved benefits measured in the operational evaluation are conservative.

Table 15. Operational evaluation limitations and effects on achieved benefits. From ref. [62].

Limitation	Description	Effect
TAP Operator	A goal of the operational evaluation was to have TAP be used by the Alaska pilots flying the aircraft. However, TAP Operators were restricted to a limited group for cost reasons. The TAP Operators consisted of four Alaska pilot interns, two NASA researchers, and four Alaska tech pilots. The pilot interns and NASA researchers, seated in the jump seat, offered TAP-inspired route modifications to the flight crew. Alaska tech pilots operated TAP from either the jump seat or front seats, depending on the flight.	The benefits calculated may not be representative of benefits in regular operational use by Alaska pilots since only about one-quarter of the valid flights had TAP operated from the front seat as intended. Alaska pilots may use TAP differently when they are responsible for its use as compared to taking input from TAP Operators located in the jump seat.
TAP intermittent availability	TAP was designed to generate advisories when the aircraft is above 10,000 ft. However, connectivity was not always available between hardware devices hosting TAP components. For this reason TAP advisories may not have been generated for some or all of the flight.	This temporary condition unique to the TAP evaluation aircraft is expected to reduce the number of requests per flight and benefits. The validation criteria was developed and applied as a partial mitigation to this limitation.
Quantity of data collected	TAP benefits were expected to be of similar magnitude to normal flight-by-flight variability of fuel burned and flight time. For this reason evaluating the benefits of TAP across a larger sample of Alaska revenue flights would have increased confidence in the quantitative benefit results. Also, flights departing Seattle in the afternoon or returning to Seattle in the morning were generally not sampled. The data collection period for the operational evaluation was curtailed for programmatic reasons.	The reduced quantity of data resulted in larger margins of error. Results may also not be representative of routes not flown by Alaska during the evaluation period.
Seasonal data collection	Data was collected during two time periods: (1) July to September and (2) January to April. There was no TAP-inspired requests during the remaining months.	This prevented the study of TAP benefits across certain times of the year and certain weather patterns.
Measurement granularity effects	TAP benefits were expected to be about the same order of magnitude as TAP and flight plan data precision. For example, flight plan predictions to route waypoints were available to the nearest one minute and 100 lbs. of fuel.	These measurement effects represented uncertainty when calculating benefits for any particular flight though they were expected to average out when calculating benefits across a relatively large number of flights.

Operational Evaluation

Limitation	Description	Effect
Identifying executed TAP advisories (TSP/TFP positive identification)	TAP was not integrated with the aircraft FMS. This required Alaska pilots to separately enter any approved TAP-inspired requests into the FMS for execution. Without an electronic record of the route modification entry, it could not be known with 100% certainty whether or not a route or altitude change executed in the FMS was TAP-inspired. Pilot interactions with the TAP Display (advisory selection, touching "ATC approved"), the TAP Operator logbook, and analyst judgment were used to ascertain whether specific route and altitude changes were TAP-inspired.	The process for identifying TAP-inspired route modifications had potential for error, resulting in possible misidentification of route changes as TAP-inspired or not.
Evaluating non-TAP maneuvers	TAP was used during the operational evaluation to decide whether it was still beneficial to climb according to the step climb listed in the flight plan. TAP could similarly be used to evaluate ATC-offered directs. The benefits of not executing a potentially detrimental maneuver was not incorporated into the benefit methodology. In addition to modifying the method, additional data collection would likely be required to identify these cases.	Not including these cases has the effect of making the benefit estimation more conservative.
Baseline flight selection	It is not possible to fly the same flight twice, once with TAP and once without TAP, to definitively quantify TAP's benefit. Baseline flights were used as an approximation for what would have happened without TAP. However, baseline flights were different from TAP flights in that they likely experienced different weather, ATC actions, and unplanned pilot maneuvers. For this reason, a single baseline flight may be less representative than using a larger sample of baseline flights. Limited TAP data collection prevented the application of a larger set of baseline flights.	Benefits for individual flights may have substantial error, though benefits averaged over many flights should partially mitigate this error.

12.12. Results

The operational evaluation of TASAR met its objectives of quantifying benefits and assessing the operational utility of TAP. They were accomplished by equipping three Alaska Airlines aircraft with TAP and conducting evaluation flights in multiple months of revenue service operations. The following sections summarize these results. Additional details are presented in references [61] and [62].

Operational Evaluation

12.12.1. Measured Benefits

Between July 24, 2018 and April 30, 2019 a total of 119 Alaska Airlines revenue flights were reviewed for analysis, including 70 flights between July 24 and September 20, 2018 and an additional 49 flights between January 23 and April 30, 2019. Ninety of those flights were determined to be valid TAP flights according to the criteria defined in reference [62]. Of those 90 valid flights, 59 (66 percent) were determined to have had at least one approved TAP-inspired request during the flight.

Recall from Eq. (1), the TAP benefit equation, that either flight plan predictions or TAP predictions could be used to calculate the $C^{predicted}$ term. Both sets of results are presented for the sake of completeness and to illustrate that a wide range of benefit estimates are possible using a small sample size.

Table 16 summarizes benefits aggregated for all 90 valid TAP flights in the operational evaluation. The first row shows the summation of the flown cost minus the predicted cost across all valid TAP flights. On average, flown cost was higher than predicted cost since both the flight plan predictions (middle column) and TAP predictions (rightmost column) are unimpeded predictions, and unplanned deviations were common on most flights (e.g., ATC vectors, maneuvering for weather). The second row similarly shows this summation for baseline flights. The cost change is shown in the third row, which is calculated as the first row minus the second row. Since there was a reduction in cost attributed to TAP, the cost change is multiplied by -1 to provide the benefit attributed to TAP in row 4. Row 4 is divided by the number of valid flights (90) to obtain the average cost saving per flight calculated using flight plan predictions (\$97.00/flight) and TAP predictions (\$96.93/flight). The standard deviation of the benefit is also shown to indicate the spread of flight-by-flight benefits. The Margin of Error (MoE), defined as half the width of the confidence intervals corresponding to 80 and 95 percent confidence levels

Table 16. Aggregate TASAR benefit results corresponding to 90 valid flights. From ref. [62].

Item	Flight Plan $C^{predicted}$	TAP $C^{predicted}$
$\sum_{TAP\ flights}(C^{flown} - C^{predicted})$	\$570.88	\$2,056.25
$\sum_{baseline\ flights}(C^{flown} - C^{predicted})$	\$9,300.56	\$10,780.19
Total cost change due to TAP (\$)	-\$8,729.68	-\$8,723.93
Total TAP benefit (\$)	\$8,729.68	\$8,723.93
Benefit per valid flight (\$/flight)	\$97.00/flight std dev=\$274.28 MoE=\$37.05, CL 80% MoE=\$56.67, CL 95%	\$96.93/flight std dev=\$269.30 MoE=\$36.38, CL 80% MoE=\$55.64, CL 95%
Benefit per valid flight (min/flight)	0.84 min/flight std dev=3.84 min MoE=0.52 min, CL 80% MoE=0.79 min, CL 95%	0.58 min/flight std dev=4.56 min MoE=0.62 min, CL 80% MoE=0.94 min, CL 95%
Benefit per valid flight (gal/flight)	32.1 gal./flight std dev=89.6 gal MoE=12.10 gal, CL 80% MoE=18.51 gal, CL 95%	35.2 gal/flight std dev=81.4 gal MoE=11.00 gal, CL 80% MoE=16.82 gal, CL 95%

Operational Evaluation

(CL), is shown below the standard deviation. The time and fuel benefit estimation are then shown in the final two rows.

The approximately \$270 standard deviation indicates a relatively large spread of cost savings around the \$97/flight average. Cost savings due to TAP were estimated to range from about -\$500 to about \$1,200 as shown in Figure 39. Any flight could be impacted by events unrelated to TAP that increase or decrease cost savings. Flights with negative cost savings had (1) a non-TAP event that negatively impacted the TAP flight, (2) a non-TAP event that positively impacted the baseline flight, or (3) a combination of negative and positive events that impacted both the TAP and baseline flights, respectively. Similarly, it would be difficult to distinguish the cost savings from noise for flights with savings between about -\$500 to about \$500 with the exception of \$0 cost savings that correspond to flights that did not experience a TAP-inspired request (i.e., savings set to zero). Flights further to the right on the plot experienced clear benefits though the exact value of that benefit is unknown due to uncertainties caused by the baseline flight selection. The figure also shows that there is no significant difference in the benefit distribution when using the flight plan for predicted costs ($C^{predicted}$) as compared to using TAP for predicted costs.

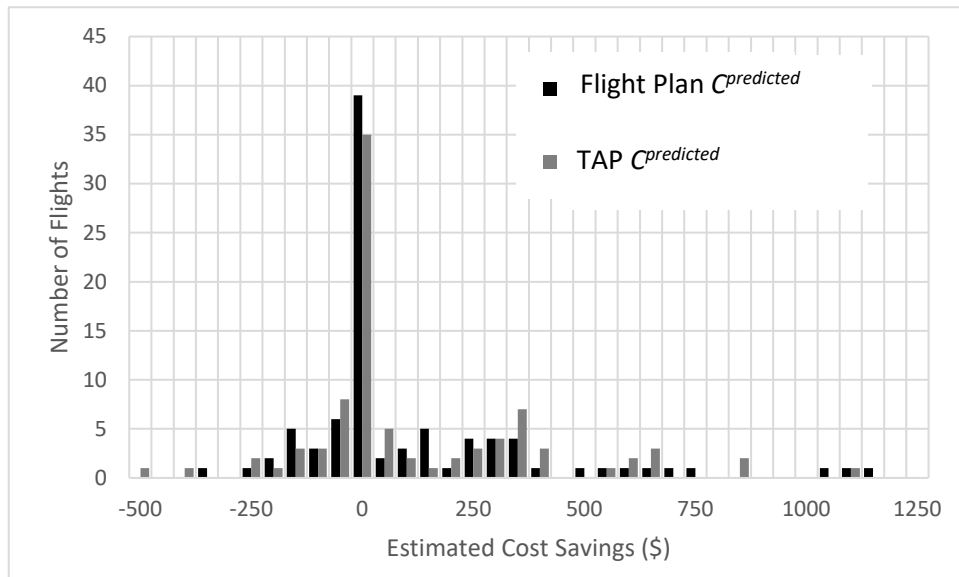

Figure 39. Distribution of estimated cost savings for the 90 valid flights. From ref. [62].

Table 17 summarizes benefits by flown flight length (wheels-off to wheels-on) for reference even though the sample size is generally too small to definitively estimate benefits. The trend across flown flight lengths was as expected, with the largest benefit per flight corresponding to flights exceeding 4 hours (\$185.49/flight) and the lowest benefit corresponding to flights less than 2 hours (-\$25.59/flight). Benefits corresponding to flights from 2 to 4 hours came in between (\$78.99/flight). The majority of benefits were concentrated to a few flights with estimated benefits exceeding \$400/flight. On flights from 2 to 4 hours, 85 percent of the benefits were attributed to 4 of the 51 flights. Similarly, on flights exceeding 4 hours, 70 percent of the benefits were attributed to 5 of the 27 flights.

TAP was intended to be used by the aircrew from the front seat. However, TAP was used by an Alaska Airlines tech pilot from the front seat during only 22 of the 90 valid flights. An additional 12 flights had either an Alaska Airlines tech pilot or NASA researcher in the jump seat advising a

Operational Evaluation

Table 17. Aggregate TASAR benefit results by flight length. From ref. [62].

Item	Flown Flight Length		
	0 to 2 hours	2 to 4 hours	4+ hours
Total valid flights	12	51	27
With approved request	5 (42%)	31 (61%)	23 (85%)
Without approved request	7 (58%)	20 (39%)	4 (15%)
$\sum_{TAP\ flights} (C^{flown} - C^{predicted})$	\$236.71	\$743.47	-\$409.30
$\sum_{baseline} (C^{flown} - C^{predicted})$	-\$70.35	\$4,772.06	\$4,598.85
Total cost change due to TAP (\$)	\$307.07	-\$4,028.59	-\$5,008.15
Total benefit (\$)	-\$307.07	\$4,028.59	\$5,008.15
Benefit per valid flight (\$/flight)	-\$25.59/flight (std dev=\$59.83)	\$78.99/flight (std dev=\$275.34)	\$185.49/flight (std dev=\$307.41)
Benefit per valid flight (min/flight)	0.10 min/flight (std dev=0.35 min)	0.43 min/flight (std dev=3.46 min)	1.94 min/flight (std dev=5.06 min)
Benefit per valid flight (gal/flight)	-12.44 gal/flight (std dev=29.57 gal)	29.29 gal/flight (std dev=93.78 gal)	57.07 gal/flight (std dev=92.76 gal)

flight crew with no TAP experience in the front seats. Similarly, the remaining 56 flights had non-airline pilot interns operating TAP from the jump seat.

Table 18 summarizes benefits by type of TAP Operator and position in the cockpit. The highest achieved benefits occurred when Alaska Airlines tech pilots operated TAP from the front seat

Table 18. Aggregate TASAR benefit results by TAP Operator. From ref. [62].

Item	TAP Operator		
	Alaska Tech Pilot from Front Seat	Tech Pilot or NASA from Jump Seat	Non-Airline Pilot Intern from Jump Seat
Total valid flights	22	12	56
With approved request	13	8	38
Without approved request	9	4	18
Flown flight length			
0 to 2 hours	3	4	5
2 to 4 hours	17	2	32
4+ hours	2	6	19
Mean flown flight length	3.05 hours	3.47 hours	3.61 hours
$\sum_{TAP\ flights} (C^{flown} - C^{predicted})$	-\$1,369.39	-\$165.36	\$2,105.62
$\sum_{baseline} (C^{flown} - C^{predicted})$	\$3,136.03	\$1,554.87	\$4,609.66
Total cost change due to TAP (\$)	-\$4,505.42	-\$1,720.22	-\$2,504.04
Total benefit (\$)	\$4,505.42	\$1,720.22	\$2,504.04
Benefit per valid flight (\$/flight)	\$204.79/flight (std dev=\$419.16)	\$143.35/flight (std dev=\$221.06)	\$44.71/flight (std dev=\$192.29)
Benefit per valid flight (min/flight)	2.34 min/flight (std dev=5.23 min)	1.47 min/flight (std dev=2.72 min)	0.11 min/flight (std dev=3.23 min)
Benefit per valid flight (gal/flight)	60.56 gal/flight (std dev=132.9 gal)	44.45 gal/flight (std dev=83.65 gal)	18.21 gal/flight (std dev=65.51 gal)

Operational Evaluation

(\$204.79/flight). These achieved benefits were higher than when TAP was operated from the jump seat by an Alaska Airlines tech pilot or NASA (\$143.35/flight) or by a non-airline pilot intern (\$44.71/flight). As stated earlier, when operated from the jump seat, TAP was not within the field of view of the flight crew, nor was the flight crew trained on its capabilities and proper use. Instead, the TAP Operator interacted with TAP and relayed TAP recommendations to the flight crew. Without the flight crew incorporating TAP into their scan and directly interacting with it, its ability to inform flight crew decisions was diminished, and this is reflected in the lower achieved benefits with TAP operated from the jump seat.

Considering the three types of TAP Operators (i.e., Alaska Airlines tech pilot, NASA researcher, or non-airline pilot intern), an Alaska Airlines tech pilot serving as TAP Operator in the jump seat was more likely to have their recommendations accepted by the flight crew based on their status as an Alaska Airlines pilot. Similarly, flight crews were more likely to be receptive to senior NASA researchers with deep experience in the technology. The interns were at the greatest disadvantage due not only to their location in the jump seat but also to their junior status as neither airline pilots nor NASA technology experts. Their challenge was to convince seasoned airline pilots to request changes to the aircraft's route on the basis of recommendations from technology with which the flight crew had no training and could not readily interact. The resulting effect is indicated in the much lower achieved benefits by the intern TAP Operators.

In contrast, the condition where TAP's greatest influence could be applied was with Alaska Airlines tech pilots, well trained in TAP and motivated to use the technology, serving as both a flight crew member and TAP Operator in the front seat. This condition allowed TAP to be fully integrated into flight crew scans and decision making as intended, and the effect is reflected in the greater achieved benefits. The benefit of about \$200/flight when TAP was operated from the front seat indicates that the overall estimated benefit of \$97/flight may underestimate future benefits if TAP is exclusively used by trained pilots from the front seat, as it was designed and intended to be used. It is expected that benefits may increase further as flight crews build experience and familiarity with the technology, thereby increasing its use.

12.12.2. Comparison to Model Estimate

Prior to the Alaska Airlines operational evaluation, a fast-time simulation analysis was performed to estimate the benefits of using TAP on Alaska Airlines aircraft (Section 5.3.2, p22). That study examined the potential for benefits by use case and aircraft type. The use cases were (1) make a lateral change after an ATC-initiated reroute has ended, (2) make a lateral change to optimize in the presence of convective weather, and (3) change to a more wind optimal trajectory. The study was conducted using data from the summer of 2012 when there were fewer high impact convective weather events than typical. For this reason, use cases (1) and (2) did not occur frequently and did not have a significant impact on the predicted benefits. In excess of 90 percent of the benefits were attributed to use case (3) which was switching to a more wind optimal trajectory.

The model-based analysis yielded an average estimated savings of 25 gallons/flight and 2.8 minutes/flight which, when applied to Alaska Airlines' DOC and fuel costs, correspond to a fast-time simulation estimated cost savings of \$136.05/flight. The results in Table 16 (p124) show an achieved savings of 32.1 gallons/flight and 0.84 minutes/flight during the operational evaluation representing a lower estimated cost savings of \$97.00/flight. However, there is still the caveat of

Operational Evaluation

large uncertainty in these estimates due to the large variation of benefits across the modest sample size of the operational evaluation.

The use cases exercised during the Alaska Airlines operational evaluation were different than the dominant wind optimal use case exercised during the fast-time simulation study. During the operational evaluation the dominant beneficial use cases seemed to be (1) climb to a more fuel-efficient altitude and (2) make a lateral change in the presence of convective weather. It is possible that additional benefits were available if TAP had generated, and pilots had selected, more advisories to follow a more wind optimal trajectory, but this behavior was not frequently observed.

Among several possible reasons for the difference in achieved and predicted benefits, a significant factor was likely the TAP Operator. Of the 90 flights, 56 were conducted by non-airline pilot interns. As discussed earlier, their junior position relative to the flight crew may have reduced the likelihood of executing lateral path changes that occurred frequently in the fast-time simulation model, favoring instead altitude changes which a flight crew unfamiliar with TAP might more easily accept as a recommendation. There were an estimated 12 lateral or combo TAP-inspired route modifications during the 56 flights conducted with a non-airline pilot intern TAP Operator. By comparison, there were 16 lateral or combo TAP-inspired route modifications during the remaining 34 flights representing a higher rate of non-altitude TAP-inspired route modifications when either an Alaska Airlines tech pilot or NASA researcher operated TAP.

The output from the fast-time simulation model was also used to estimate an annual TAP benefit of approximately \$5.15M/year across 109 aircraft equipped with TAP. This simulation-based estimate can be updated to \$5.53M/year using the more recent operating costs for Alaska Airlines. A corresponding estimate was made using the operational evaluation results, yielding an estimated annual cost savings due to TAP of \$14.97M/year [62]. The estimate has a high degree of uncertainty due to the small sample size of valid TAP flights collected during the operational evaluation.

Exploring the differences, Alaska Airlines has a larger fleet in 2019 (approximately 180 aircraft) than when the simulation-based estimate was conducted in 2015 due to a merger between Alaska Airlines and Virgin America. The merger is one reason why the \$14.97M/year benefit estimate is higher than the simulation-based estimate of \$5.53M/year, which was based on a smaller fleet of 109 aircraft. Another reason is that the updated estimate included benefits for all routes more than 2 hours planned duration while not all Alaska Airlines routes were simulated in 2015. It should be noted that the updated estimate of \$14.97M/year is based on a combination of Alaska Airlines tech pilot and non-pilot intern TAP Operator results. Approximately double the annual benefits could be obtained if it is assumed that the Alaska Airlines tech pilot \$200/flight cost savings shown in Table 18 (p126) can be sustained if TAP is deployed for use by all pilots. Alternatively, if pilots do not consistently use TAP then the annual benefits will be lower.

12.12.3. Operational Utility Assessment

In addition to estimating the cost savings, the operational evaluation provided Alaska Airlines the opportunity to assess the operational utility of TAP to pilots and to the airline. Alaska Airlines tech pilots operated TAP on 32 of the 90 valid flights. This experience provided exposure to a variety of flight situations in which TAP's operational utility was observed. As a result, they identified at least three distinctly useful scenarios of TAP utility and benefit. They refer to these scenarios as (1) Home Run, (2) Cumulative Small Gains, and (3) Plan Validation.

Operational Evaluation

Home Run Scenarios

“Home Run” scenarios reflect those opportunities where a significant improvement to the aircraft’s route is possible relative to the flight plan route or a modified weather routing issued by ATC. An example from the operational evaluation is shown in Figure 40.



Figure 40. "Home Run" TASAR benefit case. From ref. [61]. Photo by author.

Flight planning systems generally do an excellent job of creating efficient routes, taking into account forecast weather available at the time. However, forecast inaccuracies and conservative planning can result in occasions where the forecast conditions differ significantly from the actual conditions experienced in flight. Similarly, ATC may issue conservative “playbook” routing around weather when significant en route weather is forecast, but actual conditions may be less severe or may dissipate early without timely routing relief offered to the operators. Alaska Airlines observed TAP offering significant benefits in such scenarios through monitoring the latest weather and wind information and continually refreshing the search for more efficient route opportunities.

Cumulative Small Gains Scenarios

“Cumulative Small Gains” scenarios generate savings on a much smaller scale per individual instance but may aggregate into significant cumulative savings for the airline through multiple requests on a given flight and across many flights. An example of this scenario is shown in Figure 41. They leverage the availability of a flight crew to “fine tune” the route during periods of low workload (often the majority of the en route segment). The flight crew minimizes impacts to ATC workload by monitoring the voice frequency to avoid congested periods and making at most one request per sector. TAP remains vigilant for benefit opportunities no matter how large or small.



Figure 41. "Cumulative Small Gains" TASAR benefit case. From ref. [61]. Photo by author.

Operational Evaluation

Since TAP has no minimum threshold for savings when presenting route modification options to pilots, the flight crew will have the opportunity to act upon even minor route modification advisories at their discretion. Such opportunities can emerge, for example, when TAP receives a wind update (an hourly occurrence during this operational evaluation). The updated winds, which can be several hours more recent than winds used by the flight planning system, will occasionally favor an earlier or delayed climb to a higher altitude or a non-direct route between flight plan waypoints as shown in Figure 41.

Plan Validation Scenarios

“Plan Validation” scenarios became apparent during the operational evaluation as pilots used TAP to consider and then reject a prospective change from the flight plan. The benefit, in this case, is not the generation of savings through identifying and executing an improvement to the current route. Rather, the benefit is in preempting an adverse consequence (i.e., increase in direct operating cost) that would have resulted from an uninformed route modification decision by the flight crew. It is common for flight crews to make occasional requests to ATC to achieve a seemingly more optimal route using rules of thumb and optimization information available from onboard sources. The “up and straight” philosophy can lead pilots to seek routing short cuts and climbs to the optimum altitude indicated by the FMS at the earliest opportunity, despite the recommendations of the flight plan. However, such decisions can sometimes be detrimental to optimization. An example of Plan Validation is shown in Figure 42, where a short cut is shown by TAP to be not beneficial.

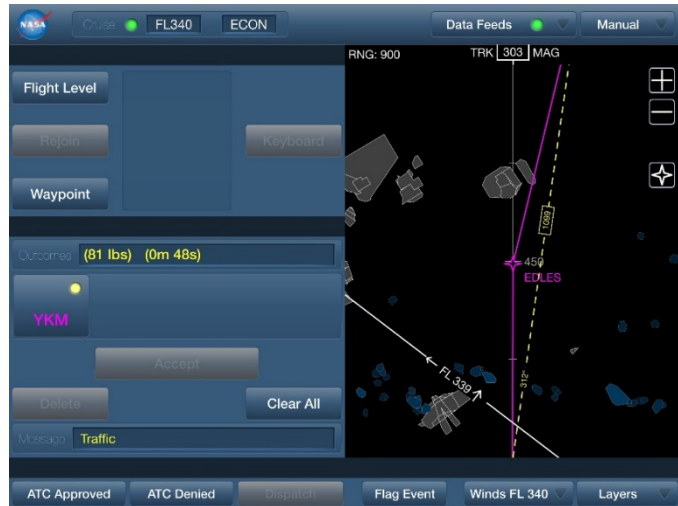

Figure 42. "Plan Validation" TASAR benefit case.
From ref. [61].

Situation Awareness

An additional area of TAP operational utility is the SA provided by the integration of various data sources and route probing functionality. Though not a primary benefit mechanism wherein TAP scans for route optimization opportunities and displays these to the flight crew, it assisted pilots in proactive decision-making, sometimes resulting in operational efficiency benefits. For instance, in the scenario depicted in Figure 42, the “traffic aware” aspect of TAP provided the TAP Operator and flight crew with advance notice of conflicting traffic and the subsequent ATC instruction to descend 2000 feet for traffic. According to TAP, retaining this new cruise altitude for the duration of the flight would have cost over 400 lbs of fuel. TAP assisted in identifying the soonest opportunity to request a climb back to the original altitude.

Culture Change

The full potential for achieving TASAR benefits will be driven by three factors: opportunity, approvability, and action. The opportunities for route improvement must exist, the route modification must be approvable (and actually approved) by ATC, and action must be taken by the flight crew to request the route modification. As an optimization tool, TAP is designed to address the first and second factors directly: it monitors the flight vigilantly for beneficial route

Operational Evaluation

modification opportunities, and it increases approvability by accounting for ATC constraints such as nearby traffic in its advisories. TAP indirectly addresses the third factor, action, by incorporating human-centered principles in the user interface design to maximize system usability. But action will also be driven over time by accumulated experience using TAP and a *culture change* wherein flight crews engage more frequently and proactively in route optimization throughout the flight and further integrate technology such as TAP into that role. Alaska Airlines expects that TAP will accelerate this culture change toward proactive optimization engagement, resulting in increased operational benefits as the culture change unfolds.

12.13. Outcomes of the Operational Evaluation

The completed operational evaluation of TASAR in partnership with Alaska Airlines has produced six key outcomes. Many relate to the original objectives NASA and Alaska Airlines each brought to the activity, while the others speak to the technology's maturity and its future.

Outcome #1

Implementation of TAP on a commercial airliner and approval for revenue service operations have been successfully achieved, providing concrete evidence to industry of the feasibility of such a commercial deployment.

By conducting an operational evaluation of TASAR with an airline, NASA sought to eliminate risks and barriers for the technology's transfer to industry for commercialization. This achievement substantially reduces risk for the commercial sector by providing a reference case of a successful deployment. Such evidence increases confidence and may provide the basis for initiating commercial investment. It also eliminates the barrier of adopting technology that has only been tested in research laboratories or flight-test aircraft. Through this activity, deployment of TAP to one of the commercial sector's key target environments (an airliner) has been successfully accomplished.

Outcome #2

The estimated cost savings achieved in the TASAR operational evaluation confirmed the expectations set by the model-based estimates produced beforehand.

With the technology deployment achieved, NASA sought to validate the projected cost savings in flight optimization using actual airline flight data. For the TASAR flights conducted by the Alaska Airlines tech pilots, which most closely matched the mature-state operations represented by the modeling and intended for the technology, the average cost savings exceeded the model estimate. Given the limited number of flights and the wide variance in estimated benefits achieved, there remains uncertainty in how benefits would accrue for an airline in the long term. However, this dataset provides as much certainty as could be achieved in a limited trial activity with a reasonable level of investment. For Alaska Airlines, the evidence it produced was sufficient to declare the predicted savings to be genuine.

Operational Evaluation

Outcome #3

TAP's prototype functionality demonstrated diverse operational utility to flight crews in a commercial airline cockpit, while also inspiring the airline to generate many new ideas for functional growth.

In addition to needing to see quantitative evidence of benefits, Alaska Airlines sought to evaluate the operational utility of TAP. With even just a limited number of hands-on evaluation flights, Alaska Airlines discerned several practical categories of TAP operational utility, each of which supports and builds upon the prized optimization culture of their airline. Furthermore, their experience using TAP triggered ideas for new functionality, new data sources and optimization objectives, and additional aircraft systems to be integrated with TAP. This perspective validates TAP's design goal of serving as an inspiration and platform for growth in airborne trajectory management.

Outcome #4

Alaska Airlines has initiated a commercial development trial of TASAR with the expected outcome of deploying TAP to all aircraft in the airline's fleet.

Alaska Airlines invested in the TASAR partnership with NASA having seen in 2013 the strong potential for both economic and operational benefits of the technology. Their expectation was to pursue fleet-wide deployment if these benefits could be verified through the operational trial. With the benefits now confirmed, Alaska Airlines is following through by taking the next step of working with the commercial sector to deploy and verify a commercial version of the technology. This lays the groundwork for fleet-wide deployment, which they have indicated will be to both their Boeing and Airbus fleets.

Outcome #5

Following Alaska Airlines' lead, additional airlines are evaluating TASAR for their fleets.

Several major U.S. airlines followed the Alaska Airlines operational evaluation of TASAR while it was underway. The sustained interest was evident from the repeated requests for briefings and demonstrations made to NASA and calls placed to Alaska Airlines. As the operational evaluation concluded, Alaska Airlines communicated the success of the trial at several industry venues, including the 2019 Global Connected Aircraft Summit in San Diego and in a joint briefing with NASA at the 2019 EFB Users Forum in Chicago. Their declaration of success cemented a growing interest by at least a half-dozen airlines to begin investigating TASAR, with some taking steps to conduct their own commercial trials.

Operational Evaluation

Outcome #6

NASA completes its work on TASAR, having achieved Technology Readiness Level 7.

The operational evaluation of TAP on Alaska Airlines aircraft in revenue service was equivalent to a “system prototype demonstration in an operational environment,” thereby meeting the criteria for TRL 7 [64]. In further substantiation, the prototype software (TAP) had “all key functionality available for demonstration and test.” TAP was “well integrated with operational hardware/software systems demonstrating operational feasibility.” The trial met the TRL 7 exit criteria by producing “documented test performance demonstrating agreement with analytical predictions.” Although it is uncommon for a NASA aeronautics technology to reach such high TRL while still in NASA’s portfolio, the outcomes listed here validate the productivity of the investment toward the likely achievement of successful technology transfer and commercial implementation.

13. Technology Transfer and Beyond

As stated in Chapter 4, the TASAR project was initiated with the principal objective of positioning NASA's state-of-the-art airborne trajectory management technology for transfer to industry such that it would "stick." At a minimum, such successful technology transfer requires commercialization of the technology, which in turn requires suppliers and a market. To be sustainable, it needs either a growing market or the ability to grow the technology. Both attributes are possible with TASAR. The following sections discuss the emerging commercial market and the derivative products achievable from TASAR, some of which are already under consideration by industry, that could build upon TAP's capabilities in the near term and foster an evolution of airborne trajectory management toward operational autonomy in the long term.

13.1. Commercial Market

TASAR technology transfer was pursued with the goal of making TASAR ubiquitously available to potentially all aircraft operators in the U.S. market. As no single industry supplier serves all operators, exclusive licensing was not considered for this technology. Limited exclusive licensing with market carve-outs was also determined not to be a good fit, given that operator classes are still too large for one supplier, and other market parameters like geographic region are unworkable because operator aircraft crisscross the country. Instead, licenses were offered on a non-exclusive basis to allow multiple suppliers to potentially commercialize the technology. In addition to more broadly reaching the aircraft operator community, having multiple suppliers is good for growing a TASAR industry in that it incentivizes companies to each distinguish their TASAR offering by innovating beyond the NASA-developed baseline, a key project goal.

Industry's commercial interest in TASAR started within two years of project initiation and broadened considerably by the end of the project. The interest did not emerge in a single sector of the industry, but rather from a broad base that cut across multiple industries within the aviation supplier community. Though unexpected, it also made sense given TASAR's intersecting position between multiple systems and functions regarding aircraft operations. Table 7 (p39) lists the industries that made specific inquiries to NASA on TASAR licensing. The diversity is self-evident and highlights the breadth of commercial interest in TASAR. Commercialization by multiple crosscutting industries increases market coverage by providing aircraft operators with access to TASAR through a variety of alternative mechanisms thereby averting the need to necessarily divest from any of their existing suppliers in order to get TASAR onboard.

The potential customer market of aircraft operators is also diverse. The initial market targeted in NASA's TASAR research was the U.S. airline community, which led to the operational evaluation being conducted in an airline environment. The evaluation caught the attention of many dominant air carriers and has resulted in multiple airline inquiries to NASA and to potential commercial suppliers. Multiple airlines talking to multiple suppliers is a healthy indicator of an emerging initial TASAR market. Ironically, airlines are not necessarily the best initial market for a new technology. Their historically thin profit margins have typically not permitted them to be the vanguard of technological advances, though plenty of exceptions certainly have occurred. One strong advantage the airlines have is that their fleets often consist of many aircraft of the same type, making it more economical to deploy a certified system across the fleets. However, as more aircraft types are equipped, deployment to other parts of the operator market will become easier. Business

Technology Transfer and Beyond

and high-end General Aviation represent opportunities for significant market growth, as they may have additional resources and the propensity to gravitate toward adopting new technology. Other potential beneficiaries of TASAR in its current form would include regional and fractional airlines and the U.S. military. The latter two operators in particular may achieve benefits from TASAR in that they generally are not based at capacity-constrained airports where flow restrictions may impede the approval of route modifications.

To assist potential suppliers in estimating TASAR benefits for potential customers, and to assist operators in assessing various fleet deployment strategies and economics, NASA produced several “tech transfer products” for use by the emerging TASAR community. The first product, shown in Table 19, is a conservative estimate of annual TAP benefits for the top 10 U.S. airlines (based on annual domestic CONUS operations), using cost savings experienced by Alaska Airlines in the operational evaluation as a function of flight length (Table 17, p126) [62]. The number of aircraft that were considered candidates to be equipped with TAP were estimated and are shown in the middle column. Generally, modern mainline jets were considered candidates. Regional jets and older aircraft were assumed to not be candidates for TAP for the purpose of this calculation. Also, the fleet size should be considered approximate since new aircraft regularly enter airline fleets, and older aircraft are retired. Benefits for aircraft types that have recently been introduced by an airline were not quantified due to insufficient historical cost and flight frequency data. Some of the limitations of this estimation method are the city pairs used by Alaska Airlines potentially not providing the same benefits to other city pairs of similar flight length, and the generalization of benefits by only three flight-length categories. The method also did not account for any competitive effect if all aircraft were simultaneously using the technology and potentially competing for ATC approval. (Modeling was not conducted in this project to assess whether or to what degree this would affect benefits. However by the time this level of equipage could realistically be achieved, the FAA Data Comm program will likely be providing full en route services which may significantly change the landscape in airspace usage and request procedures using data link.) Given these limitations, the method provides a first cut estimation of annual benefits for airlines based on fleet size and flight lengths. The estimates may be conservative for the same reasons highlighted in reference [62] for the Alaska Airlines operational evaluation.

Table 19. Estimated annual TASAR cost savings for the top 10 U.S. airlines. From [62].

Airline	Estimated Aircraft that are Candidates to be Equipped with TAP	Estimated Annual Cost Savings due to TAP
Alaska Airlines	180	\$14.97M
Allegiant Air	37	\$1.41M
American Airlines	831	\$52.29M
Delta Airlines	466	\$23.61M
Frontier Airlines	62	\$4.38M
JetBlue Airways	63	\$6.69M
Southwest Airlines	754	\$36.47M
Spirit Airlines	61	\$4.86M
Sun Country	30	\$1.41M
United Airlines	562	\$23.26M

Technology Transfer and Beyond

The second “tech transfer product” is a TAP Benefits Estimation Calculator, a spreadsheet that duplicates the computations used to produce the cost-saving estimates in Table 19. The tool allows an analyst to refine the estimates for the top 10 airlines, or to produce estimates for an unlisted operator, by adjusting various input parameters. For instance, the default values for fuel cost, direct operating cost (excluding fuel), and number of aircraft in a given fleet can be modified. The spreadsheet also contains an adjustable fuel-burn-rate scaling factor relative to the Boeing 737-900ER (the aircraft used in the operational evaluation). The analyst may also modify the number of annual flights for each aircraft type, adjust the assumed time and fuel savings provided by TAP, and even adjust the percentage of flights where TAP is used and at least one request is approved. The tool outputs the estimated annual time, fuel, and cost savings per aircraft and for that aircraft-type fleet. The same limitations apply but are partially mitigated by the adjustability of some key parameters.

The third “tech transfer product” is a description of the methodology for using the actual TAP software in a standalone model environment to refine the estimation of TAP benefits. The achieved benefits data that were used to generate the annualized benefits results in Table 19 are restricted to the routes actually flown during the operational evaluation and may not accurately represent the fuel and time benefits achievable between other city pairs and regions of the U.S. To partially mitigate this limitation, the TAP optimization algorithm can be exercised in a stand-alone condition to obtain TAP benefit opportunity estimates between different city pairs, effectively acting as an alternative data source for TAP benefit estimations versus the operational evaluation. This methodology produces idealized opportunity benefits data rather than achieved benefits data as reported for the Alaska Airlines operational evaluation, thus not accounting for factors addressed by the baseline flights (e.g., ATC and pilot actions independent of TAP). The methodology is detailed in Appendix G of reference [62] and has been exercised on several of Alaska Airlines’ city pairs not flown during the operational evaluation. TAP software licensees have the capability to exercise this methodology to generate their own customized benefit estimates for potential TASAR customers.

13.2. Derivative Opportunities

To generate the creative environment for airborne trajectory management to flourish and grow in the industry, the TASAR technology transfer strategy intended to foster competition such that TASAR capabilities are continually enhanced and expanded. The purpose of TAP, in fact, was to be a platform for innovation where commercial companies are expanding connectivity, diversifying input data, and enhancing functionality with the goal of eventually enabling new applications. The following sections list some of the ideas that have been discussed or explored. The descriptions distinguish between the initial TAP prototype developed by NASA and tested in this project and the possible derivatives of TAP that industry could build from this foundation. The incorporation of safety-related data or functionality into TAP derivatives would warrant revisiting the technology’s intended function and performing the appropriate hazards analysis.

13.2.1. Expanding Connectivity

The TAP prototype was designed to connect to specific onboard avionics devices and off-board internet sites, thereby providing a good representation of the aircraft’s state and operating environment. It led to a demonstration of how this limited, yet unprecedented, connectivity can be used to feed flight optimization algorithms and produce measurable operational benefits. However,

Technology Transfer and Beyond

the connectivity was all one way: data flowing into TAP. The next frontier for TAP derivatives is to establish two-way connectivity to systems onboard and off the aircraft.

Dispatch Connectivity: Airlines currently use the Aircraft Communications Addressing and Reporting System (ACARS) for coordination between flight crews and dispatchers. Air/ground coordination could be significantly improved by enabling the two-way exchange of candidate route modifications, as well as the constraints and objectives that go into their determination. TAP's internet connectivity provides a more efficient and data-rich channel for flight crews and dispatchers to confer on significant changes to the aircraft's route. Reference [65] is a candidate concept of operations for Multi-Agent Air/Ground Integrated Coordination (MAAGIC) between flight-deck and dispatch technologies for route optimization. MAAGIC leverages connectivity between these technologies to enable cross-checking of candidate routes against the potentially different constraints known to the air and ground systems and to support rapid coordination between flight crews and dispatchers on post-departure flight optimization opportunities.

FMS Connectivity: Once a route modification has been identified, a pilot using the TAP prototype enters it by hand into the FMS. The process can be cumbersome and prone to error, particularly if multiple off-route waypoints are involved. FMS manufacturers are developing new certified mechanisms to enable EFB applications to send data securely to the FMS, including routes. This capability is perfectly suited to incorporating an export function into a TAP derivative whereby route modifications could be auto-loaded into the FMS with minimal effort and maximum accuracy. In addition to easing workload and reducing manual data entry errors, auto-load would also facilitate the procedure of cross-checking TAP time/fuel estimates with the FMS and verifying routes using onboard weather radar.

ATC Connectivity: Once TAP's solutions and estimates are verified, a pilot using the TAP prototype system makes a voice request for the route modification to ATC. The design of the TAP prototype was heavily influenced by the constraints of a voice-request environment. Route modifications were limited to two off-route waypoints, which in turn were limited to those listed in a published waypoint database. These design restrictions greatly facilitated voice requests but may have compromised the benefits achievable [66]. Data Comm is an emerging NextGen capability. Pilots and air traffic controllers equipped for this capability can quickly send and respond to electronic messages instead of talking on the radio without the risks of missed or misunderstood spoken information. As the full en route services become available, TAP derivatives can be well prepared to take maximum advantage of this digital request capability. Reference [67] describes this capability in greater detail.

13.2.2. Diversifying Input Data

The data ingested into the TAP prototype provided key information on the aircraft's state, planned route, and operating environment. While each had relevance to route optimization or route-change acceptability, they were selected primarily based on data availability and were intended to represent a starting set of the much broader suite of data relevant to route optimization. The following are examples of additional data that could be incorporated.

4D Winds: A strong attribute of the TAP prototype was its use of 3D gridded winds updated regularly throughout the flight. Knowledge of current off-route and off-altitude winds enabled TAP to explore and offer route optimization opportunities in the 3D airspace. However, the winds were not treated as time varying, allowing for the possibility for some error in the downrange

Technology Transfer and Beyond

portions of the modeled trajectory in situations where wind field changes are expected during the flight. A straightforward yet beneficial enhancement would be to incorporate 4D winds while also expanding the wind field beyond the CONUS geographic limits established for the operational evaluation.

Onboard Weather Radar: Pilots rely on onboard weather radar when making decisions about acceptable routing in regions of convective activity. While the TAP prototype used only weather polygons derived from a ground-based weather data service for the Alaska Airlines operational evaluation, research was initiated in FT-3 on requirements for the incorporation of onboard weather radar data in TAP's algorithms and display. The research will need to be completed to determine requirements for a viable design, but the value to the pilot of integrating the airborne weather data was evident on several flights in the operational evaluation.

Turbulence: Ride quality is frequently cited among airlines as a dominant factor in route selection and modification. As new technologies emerge for sharing turbulence data among operators and prediction models are steadily improved, an opportunity exists to incorporate this information into TAP derivatives and expand the optimization criteria to include ride quality. Identified regions of severe or extreme turbulence can be easily incorporated as avoidance polygons requiring essentially no change to TAP functionality. More interesting is the possibility of using TAP to optimize routes in the presence of light to moderate turbulence, which might require a trade-off with cost optimization based on fuel and flight time. This new functionality, described below, would probably require 3D or 4D contour maps of turbulence prediction, such as the Graphical Turbulence Guidance (GTG) developed by the National Center for Atmospheric Research.

Volcanic Ash / Icing: These represent examples of various other atmospheric hazards that are potentially relevant to route optimization. Provided that measurements or prediction data are available and avoidance polygons can be generated, incorporation of these hazards into TAP's processing would be straightforward.

Ionizing Radiation: TAP is also ripe for incorporating innovative and unexpected data sources. An example is ionizing radiation dosimetry. There is a growing concern for the health and safety of commercial aircrew and passengers due to their exposure to ionizing radiation, particularly at high latitudes. The Nowcasting of Atmospheric Ionizing Radiation for Aviation Safety (NAIRAS) model [68] is an analytical tool that provides a global, real-time, atmospheric ionizing radiation dosimetry package for archiving and assessing radiation exposure levels at commercial airline altitudes that have potentially harmful health outcomes. Incorporating data from the NAIRAS model into a TAP derivative could support airline operational decisions for altering flight paths and altitudes for the mitigation and reduction of radiation exposure levels during solar radiation events.

FMS Parameters: With the emerging capabilities described earlier to connect EFB applications to the FMS comes the opportunity not only to push routes to the FMS but to retrieve FMS data as well. The TAP prototype included a Startup Checklist screen where the pilot would hand enter a number of parameters that were not available on an FMS data bus at the time of the Alaska Airlines operational evaluation. While acceptable for a limited trial, it could be problematic in regular line operations. A TAP derivative having direct access to FMS internal parameters could increase pilot usage of TAP. It could also be leveraged to enhance the accuracy of its trajectory predictions.

Technology Transfer and Beyond

Traffic Intent: TAP uses traffic data from ADS-B In to filter out candidate route modifications that might create a traffic conflict and therefore be unacceptable to ATC. The 2020 ADS-B Out mandate requires the broadcast of aircraft state data but not intent, which means TAP may be missing important information about a traffic aircraft's future trajectory, such as upcoming turn points or a vertical profile change. Inherited from AOP, the underlying algorithms in TAP were designed to use multiple levels of intent data. These data could be extracted from SWIM and supplied to a TAP derivative to enhance the fidelity of traffic trajectory modeling thereby reducing both false and missed alerts.

Airspace Structure: A key element of TASAR is to increase ATC approvability of route modification requests, thereby increasing operational benefits. FT-2 included observations at ATC facilities of the TASAR flight-test aircraft (see Section 11.2.4, p87). A key finding was that incorporation of a sector map into TAP and associated logic to minimize airspace structure factors (e.g., sector clipping, handoff impacts) may increase request approval rates under conditions of high controller workload. The challenges of identifying these conditions and the limited availability of relevant data sources (e.g., up-to-date sector maps, LOAs) did not warrant implementing these functions in the TAP prototype during this project. It was clear, however, that controllers were enthusiastic about this possibility.

Political Boundaries / Overflight Fees: Depending on a flight's geographic location, overflight fees may be charged when crossing certain political boundaries. The cost savings from minimizing flight time and fuel burn may be offset by these charges. TAP could factor this data into account in its cost function during route optimization and find the overall lowest cost route.

13.2.3. Enhancing Functionality

The TAP prototype put forth a powerful and unprecedented collection of functionality that was sufficient to distinguish it from other route optimization tools and thereby establish its initial marketability. Its real power, however, is the opportunity it provides to expand the functionality in new directions, even while maintaining its intended function as a route-optimization advisory tool in the cockpit. Several possibilities are described that were either envisioned early in the project but not built due to limited resources or emerged later with insufficient time or priority to be implemented.

Post-tactical optimization: The TAP prototype's route optimization function was derived from AOP's strategic intent-based conflict resolution function. This function required the aircraft's auto-flight system to be coupled to FMS navigation on a fully defined route to the destination. This allowed the TAP prototype to predict time and fuel to the destination on the current route and compare it to the same metrics for various candidate route modifications, returning the one that generated the greatest savings (and was conflict free). In this way, the TAP prototype was a "relative route" optimizer, not an "absolute route" optimizer. During the operational evaluation, Alaska Airlines recognized a need for an absolute optimization function that would be usable after significant tactical maneuvering for weather deviated the aircraft far from its FMS route. "Post-tactical optimization" would find the most cost-effective, conflict-free route from present position to the destination or other specified waypoint, thereby creating a new strategic plan. TAP's AOP heritage may be useful in that it included a prototype function called "Strategic Reroute" that performed this service [13].

Technology Transfer and Beyond

Ride Quality Optimization: The TAP prototype was developed with three optimization objective options: time, fuel, and trip cost. All three objectives related to the direct operating cost of the flight. Multiple objectives were included to show the flexibility of TAP's optimization capability, including allowing the pilot to switch between objectives during the flight. However, the fitness function of the TAP prototype's genetic algorithm could easily be modified to include other optimization objectives not related to operating cost, either as a separate objective option or in weighted combination with any of the three original metrics. A prime example would be ride quality. By integrating candidate routes through a 3D "heat map" of predicted turbulence contours, such as GTG, a TAP derivative could compute the cumulative exposure of the aircraft to turbulence and seek the route modification (lateral and/or vertical changes) that minimizes the total exposure. It would be similar to how TAP integrates routes through the 3D wind field to find the minimum fuel-burn option. As described earlier, localized areas of greater turbulence could be polygonised and avoided completely.

4D Constraint Adherence: Scheduled aircraft operations are often concerned with on-time arrival statistics. The particular desire is to avoid frequently arriving late (usually defined as 15 minutes or greater), but early arrivals can also be problematic due to gate availability. The TAP prototype's optimization algorithm was not designed to ensure solutions conformed to an arrival time window, primarily because there was no ready data source for such time constraints, but also because it was not needed to demonstrate TAP's operational value. Provided the time constraints are available, it would be straightforward to modify TAP's fitness function to require solution compliance to the constraints. A softer constraint of "get as close as you can" could also be implemented, provided the trade-off with other objectives (e.g., minimizing trip cost) could be defined.

4D Solutions: An improvement upon the 4D constraint adherence functionality would be the implementation of an additional solution advisory type: speed solutions. The TAP prototype produces lateral, vertical, and combo solutions that best meet the objectives of minimizing flight time, fuel burn, or trip cost. The airspeed is treated as an input, not an output. However, for situations in which the most economical solution would be to slow down, new functionality could enable a TAP derivative to provide that solution, either as an actual speed (or Mach) target, or more flexibly as a new Cost Index (which governs the speed profile). In fact, TAP could produce the best combination of lateral path, altitude, and speed (Cost Index) to meet an arrival time target with minimum operating cost. As before, the key will be to provide a meaningful data source for the arrival time constraints.

New Solution Patterns: The solution patterns used by TAP's genetic algorithm define the range of allowable geometry for the route modifications. The TAP prototype contained lateral patterns for one and two off-route waypoints, as did the combo patterns with an added altitude change. Other patterns could be developed that might provide additional operational utility. For example, all of the initial patterns defined the first maneuver as being executed essentially right away, thus a delayed first maneuver (e.g., future turn-out point or climb/descent point) was not possible. This could easily be added to the existing patterns. Another pattern that was implemented in AOP but not inherited by the TAP prototype was a "lateral offset" pattern that mimicked a side-step maneuver. A particularly useful pattern to implement would be a vertical pattern with multiple climb/descent points, including a delayed first maneuver. Improving upon the current design for TAP vertical solutions, which assumes an immediate climb/descent is maintained until the top-of-descent prior to arrival, the proposed pattern would assist the pilot in step-climb planning using updated winds and local constraints (e.g., weather, traffic, turbulence).

Technology Transfer and Beyond

Handoff Monitoring: Furthering the discussion above on airspace structure, a key finding from FT-2 was the importance to air traffic controllers on the timing of route modification requests relative to handoff between sectors. With the incorporation of sector boundary data and some basic timing assumptions, a TAP derivative could infer the handoff status of the aircraft between sectors and advise the flight crew on the best time to make the ATC request to minimize the workload of request deferment or possible denial due to the transitioning of aircraft control between sectors. Though it is uncertain whether this function would accrue measureable cost savings, it would certainly facilitate pilot/controller procedures which would likely improve the perceived utility of TASAR by both parties.

Machine Learning: ATC approval of TASAR requests is dependent on some factors that are deterministic and have available data, such as proximate traffic conflicts and SUAs, but also many other factors that are non-deterministic or involve information not readily available to airspace users. For instance, air traffic controllers are bound to many intricate requirements spelled out in inter-facility LOAs that affect what they can or cannot approve. Other factors such as sector capacity metrics, weather impacts, and local restrictions around arrival/departure flows of major airports, further complicate the ability to predict whether any given route modification request is approvable or whether slight modifications might help. This may be a good application for machine learning algorithms that accumulate a knowledge base and mine the data for characteristics that may increase ATC approval probability. This approach may improve upon other techniques that bias toward historically approved routes in that it would allow both ATC and aircraft operators to evolve toward greater airspace access, using as much operational flexibility as the current conditions permit.

13.3. TASAR Roadmap

In Chapter 2, the discussion on TASAR's motivation detailed how it was conceived as a catalyst for achieving a future vision of operational autonomy for airspace users. By pursuing a strategy of technology insertion, TASAR would place key elements of the future technology into service today in a non-safety-critical role to enable its maturation and verification in an operational environment. Simultaneously, TASAR would initiate a culture change by acclimating the commercial aviation community to the idea of cockpit-based proactive trajectory management. By introducing the technology and evolving the culture, TASAR could potentially generate momentum toward the future vision.

Since planting these seeds in no way guarantees the final outcome, a high-level roadmap [7] was devised to chart a potential path from TASAR to the autonomy vision of full "Airborne Trajectory Management" (ABTM). The roadmap was devised such that each interim step could also be a viable and beneficial ending point, should the future vision be unobtainable. The roadmap's endpoint uses the general term "ABTM" instead of "AFR" as described in Chapter 2 in order to decouple the envisioned capability from NASA's proposed concept of implementation. While this roadmap was developed primarily with today's IFR operators in mind, the applications from TASAR to ABTM are applicable to new types of operations as well, for example Urban Air Mobility (UAM) as described in reference [69]. In UAM, trajectory management automation onboard the aircraft would serve both safety-critical functions for traffic separation and non-safety-critical flight optimization functions for conserving energy use while efficiently adjusting to dynamic constraints along the flight and at the destination.

Technology Transfer and Beyond

Shown in Figure 43, the five-step roadmap begins with 1: Basic TASAR as described in this report. The subsequent steps include 2: Digital TASAR, adopting the use of Data Comm for route modification requests and approvals; 3: 4D TASAR, adding the speed dimension, time constraints, and integration with time-based arrival flow management processes under development by the FAA; 4: Strategic ABTM, adding user authority to define and modify downstream, strategic portions of the trajectory; and 5: Full ABTM that ultimately incorporates the functions and

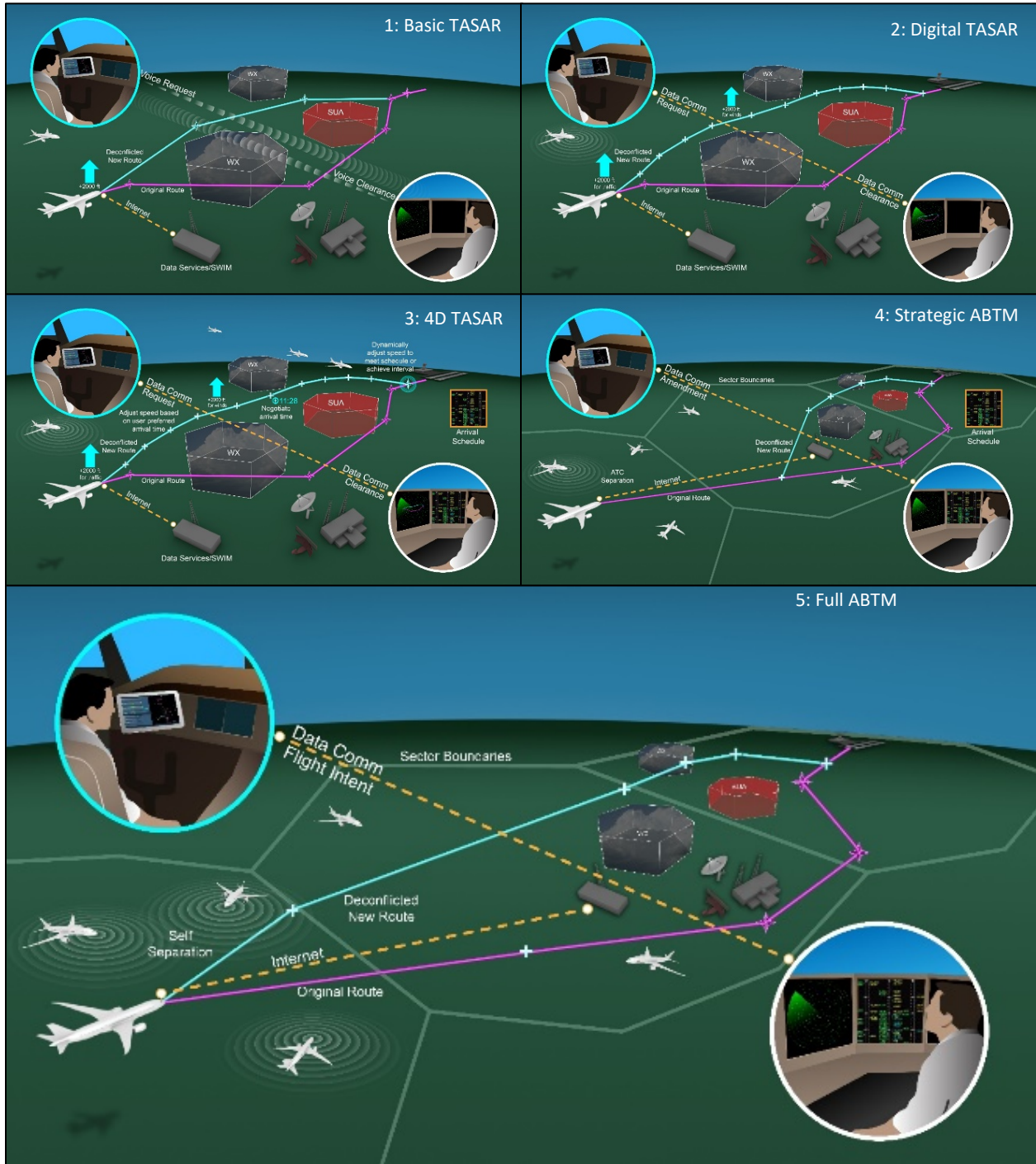

Figure 43. Roadmap from TASAR to full airborne trajectory management. From ref. [7].

Technology Transfer and Beyond

responsibilities of self-separation in the current airspace sector, enabling full operational autonomy.

The roadmap represents a sustainable progression in which each additional integration step provides new benefits. It takes advantage of existing NextGen programs and industry standards development, while minimizing the number of hardware upgrades required of airspace users to take advantage of these advanced capabilities to achieve dynamically optimized business trajectories. Just like TASAR, each subsequent step in the roadmap provides operational benefits to first adopters so that investment decisions do not depend upon other segments of the user community becoming equipped before benefits can be realized. The issues of equipment certification and operational approval of new procedures are addressed in a way that minimizes their impact on the transition. This is accomplished by deferring a change in the assignment of separation responsibility until a large body of operational data (acquired during all previous steps) is available to support the safety case for this change in the last roadmap step. This design philosophy also delays paradigm shifts in the control of air traffic that could create barriers to transition. It is only after extensive experience has been gained through operations in the earlier steps that rules and procedures would be changed to fully exploit new capabilities. Ultimately, each roadmap step is supportable on its own merits, enabling the choice by each operator on how far to proceed on the roadmap.

To progress forward on this roadmap, the industry can follow the model of TASAR by implementing the new capabilities in an optional capacity at first, such that it does not replace an operationally required function until the capability is matured. For instance, Digital TASAR could be implemented using the same TAP solution complexity as was developed for voice requests, thereby making TASAR requests by Data Comm optional until it becomes standard practice. Similarly, 4D TASAR could be implemented initially for minor arrival time adjustments within the pilot's current authority until true 4D operations (e.g., required times of arrival, interval management) are fully rolled out. In fact, TASAR advancements embodied in this roadmap may actually accelerate user community adoption of these NextGen capabilities.

14. Conclusion

The commercial aircraft cockpit is among the most under-utilized workspaces in en route airspace operations. With little access to information on the traffic environment or weather beyond the range of their onboard radar, flight crews have had few if any tools to reliably improve upon the flight plan created hours earlier, even as evolving airspace conditions create new opportunities. As a result, flight crews in high-altitude airspace have largely fallen into the passive role of flight plan followers. By introducing TASAR, NASA is attempting to cultivate a transformational change: transforming flight crews from flight plan followers into proactive trajectory managers.

TASAR is at the nexus of data connectivity, onboard computing, and flight-crew decision-making, and it embodies the idea that when all three are brought to bear, the flight no longer needs to be a static execution as encapsulated in the pre-departure flight plan. Leveraging unprecedented connectivity to up-to-date operational data, TASAR gives flight crews the computational tools they need to dynamically re-optimize their trajectory throughout much of the flight. In the long term, this cultural transformation is envisioned to lead to significantly greater aircraft autonomy in airspace operations. The emergent capability to self-manage trajectories will enable future operators to safely operate amidst growing demand in the National Airspace System while providing unparalleled operational flexibility and flight efficiency.

The TASAR project was established to develop and test prototype cockpit technology for in-flight route optimization, with the intent of transferring the technology to industry as a first step toward these transformational goals. The project was formulated around a five-point strategy:

1. Fill a current need: The TASAR project would help establish a business case for the emerging “connected EFB” by developing a compelling software application for this revolutionary new platform. The software application would introduce a state-of-the-art *airborne trajectory management* function and a proactive role for pilots using it.
2. Demonstrate a clear business case: The TASAR project would focus the technology on achieving direct-operating-cost savings. The project would estimate the cost-savings benefit and make these preliminary estimates available to industry early in the project to promote interest and engagement.
3. Reduce risk of technology transfer: The TASAR project would conduct preliminary analyses of safety, human factors, and FAA authorization requirements. The project would conduct flight trials to validate the technology’s viability and robustness in real aircraft operating in the airspace system.
4. Bridge the valley: The TASAR project would seek partner airlines to conduct operational evaluations of the technology in revenue service. Operational data from the evaluations would be used to validate the preliminary benefit estimates and provide justification for industry to carry it forward.
5. Promote industry investment in basic and derivative products: The TASAR project would encourage companies to follow or participate in NASA’s activities, increasing awareness of TASAR as a foundation for technology innovation while creating an initial cadre of TASAR industry experts.

Conclusion

Each of these strategy points was achieved. The connected EFB and TASAR application were a well-suited match of platform and function, and the timing was fortuitous with ubiquitous airborne connectivity just beginning to emerge as an industry revolution. TASAR's flight optimization function provided the direct link to operational benefits that the airlines needed to build a business case for the connected EFB. NASA's preliminary, model-based benefit estimates secured initial airline interest which in turn helped to direct industry's attention toward TASAR. The project's preliminary analyses of safety, certification, and operational approval, vetted with FAA policy authors, established confidence in the industry that the TASAR application could be implemented under current regulations with minimal risk.

NASA's TASAR prototype software, TAP, offered state-of-the-art technology with unique capabilities and attributes. Its innovative functionality, industry appeal, and growth potential all contributed to its award as 2016 NASA Software of the Year and recognition as a recipient of the international 2019 R&D 100 Award. The attention paid to human factors throughout the project produced a useful and usable tool that consistently received high marks from evaluation pilots. TAP was matured through multiple high fidelity simulations and flight trials that also cemented airline interest in conducting an operational evaluation on airline aircraft in partnership with NASA.

The Alaska Airlines operational evaluation, a significant undertaking, was completed successfully. Three aircraft conducted over 100 TASAR flights in revenue service, and Alaska Airlines technical pilots identified multiple distinct applications of the technology that would clearly benefit airline operations. Quantitative estimates of achieved cost savings validated the preliminary model-based benefit estimates. Three aviation system suppliers from industry participated in the operational evaluation largely at their own expense and thus had front row seating for its implementation and assessment by a potential customer.

Evidence suggests that the technology insertion strategy of TASAR has taken root. At project completion, each of the top six U.S. airlines had expressed interest in acquiring TASAR for their fleets. Six commercial industry vendors had received preliminary evaluation licenses for TASAR, and multiple commercial license applications were submitted to NASA. These companies and others have already begun exploring derivative products around integrating TASAR with their own technology innovations and new data sources. All of this indicates the emergence of a healthy and sustainable market for TASAR and bodes well for the roadmap beyond TASAR.

The arc of the TASAR project began with an ambitious vision of aircraft operational autonomy and ended with the prototype technology on track toward commercialization by industry and adoption by the aircraft operator community as a catalyst application of airborne trajectory management. Key to this project's accomplishments was NASA's early, insightful investment in research and development of advanced technology for aircraft autonomy. This foundation enabled TASAR to rapidly progress from TRL 1 to 7, highly unusual in NASA Aeronautics but positioning TASAR well for a successful handoff to industry. If widespread adoption ensues, the cultural transformation inspired by TASAR could become a catalyst to eventually achieving the vision of aircraft operational autonomy.

15. Abbreviations

2D	two-dimensional
3D	three-dimensional
4D	four-dimensional
ABTM	Airborne Trajectory Management
AC	Advisory Circular
ACARS	Aircraft Communications Addressing and Reporting System
ACPU2	Gogo Airborne Control Processing Unit
ACSS	Aviation Communication & Surveillance Systems
ADC	Air Data Computer
ADS-B	Automatic Dependent Surveillance Broadcast
AFR	Autonomous Flight Rules
AFS	FAA Flight Standards
AIAA	American Institute of Aeronautics and Astronautics
AID	Aircraft Interface Device (also AID2)
AIR	FAA Aircraft Certification
AOP	Autonomous Operations Planner
AOSP	Airspace Operations and Safety Program
API	Application Programming Interface
APM	Aircraft Performance Model
ARTCC	Air Route Traffic Control Center
ATC	Air Traffic Control
ATD	Airspace Technology Demonstrations Project
AWC	Aviation Weather Center
AWRP	Airborne Weather Radar Processor
BADA 4	Eurocontrol Base of Aircraft Data Version 4
BFP	Baseline Finish Point
BSP	Baseline Start Point
CAS	Calibrated Airspeed
CBT	Computer Based Trainer
CD	Conflict Detection
CDTI	Cockpit Display of Traffic Information
CIFP	Coded Instrument Flight Procedures
CL	Confidence Level
CONUS	Conterminous United States
CRM	Crew Resource Management
CS	Civil Servant
CTD	Concepts and Technology Development Project
DAL	Design Assurance Level
Data Comm	Data Communications
Depr.	Depreciation
DER	Designated Engineering Representative
DOC	Direct Operating Cost
DTIF	Display Traffic Information File

Abbreviations

EDS	External Data Server
EFB	Electronic Flight Bag
EMI	Electro-Magnetic Interference
ERAM	En Route Automation Modernization
FAA	Federal Aviation Administration
FACET	Future ATM Concept Evaluation Tool
FEC	Failure Effects Classification
FMS	Flight Management System
FOB	Flight Operations Bulletin
ft	feet
FT	Flight Trials
FT-1	Flight Trial 1
FT-2	Flight Trial 2
FT-3	Flight Trial 3
Gal.	Gallons
GAMA	General Aviation Manufacturers Association
GDS	Ground Data Server
GRIB2	Gridded Binary Edition 2
GS	Ground Speed
GTG	Graphical Turbulence Guidance
HIRF	High Intensity Radio Frequency
HITL	Human-in-the-Loop
HITL-1	Human-in-the-Loop Simulation 1
HITL-2	Human-in-the-Loop Simulation 2
HMI	Human Machine Interface
IFC	In-Flight Connectivity
IFR	Instrument Flight Rules
IMC	Instrument Meteorological Conditions
IT	Information Technology
KBHM	Birmingham-Shuttlesworth International Airport, Alabama
KMGM	Montgomery Regional Airport, Alabama
KPDX	Portland International Airport, Oregon
KPHF	Newport News / Williamsburg International Airport, Virginia
KSEA	Seattle-Tacoma International Airport, Washington
KTPA	Tampa International Airport, Florida
LOA	Letters of Agreement
lbs	pounds
M	Mean
Maint.	Maintenance
MFD	Multi-Function Display
MoE	Margin of Error
Mspec	Management Specification
NAS	National Airspace System
NATCA	National Air Traffic Controllers Association
NBAA	National Business Aviation Association
NextGen	Next Generation Air Transportation System

Abbreviations

NIA	National Institute of Aerospace
nmi	nautical miles
NOAA	National Oceanic and Atmospheric Administration
NRA	NASA Research Announcement
NRS	Navigation Reference System
OEM	Original Equipment Manufacturer
OPL	Operator Performance Lab (University of Iowa)
OpSpec	Operational Specification
OSA	Operational Safety Assessment
PBGA	Pattern-Based Genetic Algorithm
PED	Portable Electronic Device
PF	Pilot Flying
PFD	Primary Flight Display
PM	Pilot Monitoring
POI	Principal Operations Inspector
RAP	NOAA “Rapid Refresh” product
RNP	Required Navigation Performance
R&D	Research and Development
SA	Situation Awareness
SAA	Space Act Agreement
SART	Situation Awareness Rating Technique
SBS	FAA Surveillance & Broadcast Services
SCAP	Standardized Computerized Airplane Performance
SD	Standard Deviation
SIGMET	Significant Meteorological Information
SIP	NASA Aeronautics Strategic Implementation Plan
SME	Subject Matter Expert
SOP	Standard Operating Procedures
STAP	Simple Text Avionics Protocol
STC	Supplemental Type Certificate
std dev	Standard deviation
SUA	Special Use Airspace
SUS	System Usability Scale
SWIM	System Wide Information Management
TAP	Traffic Aware Planner
TFP	TAP Finish Point
TSP	TAP Start Point
TASAR	Traffic Aware Strategic Aircrew Requests
TC	Type Certificate
TCAS	Traffic Alert and Collision Avoidance System
TCP/IP	Transmission Control Protocol/Internet Protocol
TDA	TAP Display Adaptor
TFP	TAP Finish Point
TG	Trajectory Generator
TRL	Technology Readiness Level
TSO	Technical Standard Order

Abbreviations

TSP	TAP Start Point
UAM	Urban Air Mobility
USB	Universal Serial Bus
UTAS	United Technologies Corporation Aerospace Systems
VFR	Visual Flight Rules
VMC	Visual Meteorological Conditions
VOR	Very-high-frequency Omnidirectional Range
WSI	Weather Services International (later, The Weather Company)
ZJX	Jacksonville Air Route Traffic Control Center
ZTL	Atlanta Air Route Traffic Control Center

16. References

- [1] Francies, D. (1946) "Safety in the Soup: Automatic Landings Now, 'Teleran' Soon, Assure All-Weather Service on the Airlines," *Popular Science*, Vol. 148, No. 3, pp74-77, March 1946.
- [2] Cotton, W. (1965) "New Directions in Air Traffic Control at Kennedy Airport," Master's Thesis, Course XVI, Massachusetts Institute of Technology.
- [3] Cotton, W. (1973) "Formulation of the Air Traffic System as a Management Problem," *IEEE Transactions on Communications*, January 1973.
- [4] Connelly, M. (1977) "Simulation Studies of Airborne Traffic Situation Display Applications - Final Report," *Electronic Systems Laboratory*, Massachusetts Institute of Technology, May, 1977.
- [5] Andrews, J. and Hollister, W. (1980) "Electronic Flight Rules: An Alternative Separation Assurance Concept." Project Report ATC-93, Lincoln Laboratory, Massachusetts Institute of Technology.
- [6] Wing, D. and Cotton, W. (2011) "For Spacious Skies: Self-Separation with 'Autonomous Flight Rules' in US Domestic Airspace," AIAA-2011-6865, American Institute of Aeronautics and Astronautics (AIAA), Washington, DC.
- [7] Cotton, W., Hilb, R., Koczo, S., and Wing, D. (2016) "A Vision and Roadmap for Increasing User Autonomy in Flight Operations in the National Airspace," AIAA-2016-4212, AIAA, Washington, DC.
- [8] NASA Aeronautics Research Mission Directorate (2017) "Strategic Implementation Plan 2017," <https://www.nasa.gov/aeroresearch/strategy>.
- [9] Wing, D. and Cotton, W. (2011) "Autonomous Flight Rules: A Concept for Self Separation in US Domestic Airspace," NASA/TP-2011-217174.
- [10] Consiglio, M., Hoadley, S., Wing, D., and Baxley, B. (2007) "Safety Performance of Airborne Separation: Preliminary Baseline Testing," AIAA-2007-7739, AIAA, Washington, DC.
- [11] Wing, D., Prevot, T., Lewis, T., Martin, L., Johnson, S., Cabrall, C., Commo, S., Homolam J., Sheth-Chandra, M., Mercer, J., and Morey, S. (2013) "Pilot and Controller Evaluations of Separation Function Allocation in Air Traffic Management." 10th USA/Europe ATM R&D Seminar, Chicago, IL.
- [12] Gogo (2016) "From the Ground Up: How the Internet of Things will Give Rise to Connected Aviation," Gogo, LLC, Chicago, IL.
- [13] Karr, D., Vivona, R., Roscoe, D., DePascale, S., and Wing, D. (2012) "Autonomous Operations Planner: A Flexible Platform for Research in Flight-Deck Support for Airborne Self-Separation." AIAA-2012-5417, AIAA, Washington, DC.
- [14] Ballin, M. and Wing, D. (2012) "Traffic Aware Strategic Aircrew Requests (TASAR)," AIAA-2012-5623, AIAA, Washington, DC.
- [15] Henderson, J. (2013) "Traffic Aware Strategic Aircrew Requests (TASAR) Concept of Operations," NASA/CR-2013-218001, NASA Langley Research Center, Hampton, VA.
- [16] Ballin, M. and Wing, D. (2015) "Method and Apparatus for Generating Flight-Optimizing Trajectories," U.S. Patent 8,977,482, issued March 10, 2015.
- [17] Henderson, J. Idris, H. and Wing, D. (2012) "Preliminary Benefits Assessment of Traffic Aware Strategic Aircrew Requests (TASAR)," AIAA-2012-5684, AIAA, Washington, DC.
- [18] Henderson, J. (2015). "Annualized TASAR Benefit Estimate for Virgin America Operations," NASA/CR-2015-218786, NASA Langley Research Center, Hampton, VA.
- [19] Henderson, J. (2015). "Annualized TASAR Benefit Estimate for Alaska Airlines Operations," NASA/CR-2015-218787, NASA Langley Research Center, Hampton, VA.
- [20] Bilimoria, K., Sridhar, B., Chatterji, G., Sheth, K., and Grabbe, S. (2001) "FACET: Future ATM Concepts Evaluation Tool," *Air Traffic Control Quarterly*, Vol. 9, No. 1, 2001, pp. 1-20.
- [21] Bureau of Transportation Statistics "T-100 Domestic Segment Database," http://www.transtats.bts.gov/Fields.asp?Table_ID=311.
- [22] Federal Aviation Administration (2017) "Authorization for Use of Electronic Flight Bags," Advisory Circular 120-76D, Washington DC.
- [23] Koczo, S. (2013). "Analysis of Operational Hazards and Safety Requirements for Traffic Aware Strategic Aircrew Requests (TASAR)," NASA/CR-2013-218002, NASA Langley Research Center, Hampton, VA.
- [24] Society of Automotive Engineers (1996) "Guidelines and Methods for Conducting the Safety Assessment Process on Civil Airborne Systems and Equipment," SAE Aviation Recommend Practice 4761.

References

- [25] Federal Aviation Administration (1988) "System Design and Analysis," AC 25.1309-1A, Washington, DC.
- [26] Federal Aviation Administration (2011) "System Safety Analysis and Assessment for Part 23 Airplanes, AC 23.1309-1, Washington, DC.
- [27] RTCA (2002) "Guidelines for Approval of the Provision and Use of Air Traffic Services Supported by Data Communications," DO-264 / EUROCAE ED-78A, Washington, DC.
- [28] Kozco, S. (2015). "TASAR Certification and Operational Approval Requirements – Analyses and Results," NASA/CR-2015-218708, NASA Langley Research Center, Hampton, VA.
- [29] Title 14 of the Code of Federal Regulations (14 CFR) parts 21, 23, 25, 27, 29, 43, 91F, 91K, 121, 125, and 135, Washington DC.
- [30] Federal Aviation Administration (2007) "Flight Standards Information System (FSIMS)," FAA Order 8900.1 Change 47, Vol. 4, Chapter 15 – EFB Operational Authorization Process, Washington DC.
- [31] Federal Aviation Administration (2012) "Authorization for Use of Electronic Flight Bags," Advisory Circular 120-76B (expired), Washington DC.
- [32] Federal Aviation Administration (2011) "Installation of Electronic Flight Bag Components", Advisory Circular 20-173, Washington DC.
- [33] Federal Aviation Administration (2017) "Type Certification," FAA Order 8110.4C, Washington DC.
- [34] RTCA (2010) "Environmental Conditions and Test Procedures for Airborne Equipment", RTCA/DO-160G, Washington DC.
- [35] RTCA (2012) "Software Considerations in Airborne Systems and Equipment Certification," DO-178B/C, Washington DC.
- [36] Federal Aviation Administration (2012) "Authorization for Use of Electronic Flight Bags," Advisory Circular 120-76B (expired), Washington DC.
- [37] Advanced Aerospace Solutions, LLC (2016) "Preliminary Analysis Report on Weather Information Display," NASA Contract NNL13AA00B Deliverable 4.15 (unpublished), Hendersonville NC.
- [38] Advanced Aerospace Solutions, LLC (2017) "Preliminary Analysis Report on TAP Software Certification Upgrade," NASA Contract NNL13AA00B Deliverable 4.8 (unpublished), Hendersonville, NC.
- [39] Advanced Aerospace Solutions, LLC (2017) "Traffic Aware Planner Validator High-Level Requirements Document," NASA Contract NNL13AA00B Deliverable 4.10A (unpublished), Hendersonville, NC.
- [40] Woods, S., Vivona, R., Roscoe, D., Lefebvre, B., Wing, D., and Ballin, M. (2013). "A Cockpit-based Application for Traffic Aware Trajectory Optimization," AIAA-2013-4967, AIAA, Washington, DC.
- [41] Woods, S., Vivona, R., Henderson, J., Wing, D., and Burke, K. (2016). "Traffic Aware Planner for Cockpit-based Trajectory Optimization," AIAA-2016-4067, AIAA, Washington, DC.
- [42] Karr, D. and Vivona, R. (2006) "Conflict Detection Using Variable Four-Dimensional Uncertainty Bounds to Control Missed Alerts." AIAA-2006-6057, AIAA, Washington, DC.
- [43] Vivona, R., Karr, D., and Roscoe, D. (2006) "Pattern-Based Genetic Algorithm for Airborne Conflict Resolution." AIAA-2006-6060, AIAA, Washington, DC.
- [44] Karr, D., Vivona, R., Woods, S., and Wing, D. (2017) "Point-Mass Aircraft Trajectory Prediction Using a Hierarchical, Highly-Adaptable Software Design," AIAA-2017-3336, AIAA Modeling and Simulation Technologies Conference, Denver, CO.
- [45] Lewis, T., Burke, K., Underwood, M., and Wing, D. (2019) "Weather Design Considerations for the TASAR Traffic Aware Planner." AIAA-2019-3616, AIAA, Washington, DC.
- [46] Burke, K., Wing, D., Woods, S., Ponthieux, J., and Lefebvre, B., "Method and Apparatus for Providing In-Flight Pilot Interface for Trajectory Optimization," U.S. Patent, 10,102,756, October 16, 2018.
- [47] Cover, M., Engler, J., Reuter, C., and Schnell, T. (2014) "TASAR Human-in-the-Loop Pilot Assessment Study Report," NASA Contract NNL12AA11C Deliverable 16B (unpublished), Cedar Rapids, IA.
- [48] Bohlen, G., Ferratt, T. (1997). End User Training: An Experimental Comparison of Lecture versus Computer-Based Training. *Journal of Organizational and End User Computing*, 9(3).
- [49] Kozco, S. (2015) "TASAR Human Factors: Certification and Operational Approval Artifacts Summary Report," NASA Contract NNL12AA11C Deliverable 17B (unpublished), Cedar Rapids, IA.
- [50] Maris, J., Haynes, M., and Woods, S. (2014) "TASAR November 2013 Flight Trial Results," NASA Contract NNL12AA06C Deliverable 27A (unpublished), Raleigh, NC.
- [51] Maris, J., Haynes, M., Wing, D., Burke, K., Henderson, J., and Woods, S. (2014) "Traffic Aware Planner (TAP) Flight Evaluation," AIAA-2014-2166, 14th AIAA Aviation Technology, Integration, and Operations Conference, Atlanta, GA.

References

- [52] Maris, J., Haynes, M., and Woods, S. (2016) "TASAR Flight Trial 2 Report," NASA Contract NNL12AA06C Deliverable 50A (unpublished), Raleigh, NC.
- [53] Idris, H., and Enea, G. (2016) "TASAR Flight Trial 2: Assessment of Air Traffic Controller Acceptability of TASAR Requests," NASA/CR-2016-219215.
- [54] Burke, K., Wing, D., and Haynes, M. (2016) "Flight Test Assessments of Pilot Workload, System Usability, and Situation Awareness of TASAR," Human Factors and Ergonomics Society (HFES) International Annual Meeting, pp61-65, 19-23 Sep. 2016, Washington, DC.
- [55] Barney, T., Underwood, M., and Buck, B. (2019) "Simulation and Flight Test Environments for the TASAR Traffic Aware Planner," AIAA-2019-3614, 2019 Aviation Technology, Integration, and Operations Conference, Dallas, TX.
- [56] Underwood, M., Lewis, T., and Barney, T. (2019) "In-flight Evaluation of the Traffic Aware Planner on the NASA HU-25A Guardian Aircraft," AIAA-2019-3615, 2019 Aviation Technology, Integration, and Operations Conference, Dallas, TX.
- [57] Wing, D., Ballin, M., Koczo, S., Vivona, R., and Henderson, J. (2013) "Developing an Onboard Traffic-Aware Flight Optimization Capability for Near-Term Low-Cost Implementation," AIAA-2013-4231, 2013 Aviation Technology, Integration, and Operations Conference, Los Angeles, CA.
- [58] Wing, D. (2015) "Achieving TASAR Operational Readiness," AIAA-2015-3400, AIAA Aviation Technology, Integration, and Operations Conference, Dallas, TX.
- [59] Roscoe, D., Vivona, R., Woods, S., Karr, D., and Wing, D. (2016). "Deploying a Route Optimization EFB Application for Commercial Airline Operational Trials," DOI 10.1109/DASC.2016.77780373, 35th 2016 IEEE/AIAA Digital Avionics Systems Conference, Sacramento, CA.
- [60] Wing, D., Burke, K., Henderson, J., Vivona, R., and Woodward, J. (2018) "Initial Implementation and Operational Use of TASAR in Alaska Airlines Flight Operations," AIAA-2018-3043, AIAA Aviation Technology, Integration, and Operations Conference, Atlanta, GA.
- [61] Wing, D., Burke, K., Ballard, K., Henderson, J., and Woodward, J. (2019) "Initial TASAR Operations Onboard Alaska Airlines," AIAA-2019-3613, AIAA Aviation Technology, Integration, and Operations Conference, Dallas, TX.
- [62] Henderson, J., Wing, D., and Ballard, K. (2019) "Alaska Airlines TASAR Operational Evaluation: Achieved Benefits," NASA/TM-2019-220400, NASA Langley Research Center, Hampton, VA.
- [63] Bureau of Transportation Statistics, 2019, Form 41, Schedule P5.2 retrieved from https://www.transtats.bts.gov/tables.asp?DB_ID=135
- [64] NASA (2013) "NASA Systems Engineering Processes and Requirements," NASA Procedural Requirement 7123.1B, Appendix E, NASA, Washington DC.
- [65] Idris, H., Bilimoria, K., Wing, D., Harrison, S., and Baxley, B. (2018) "Air Traffic Management Technology Demonstration – 3 (ATD-3) Multi-Agent Air/Ground Integrated Coordination (MAAGIC) Concept of Operations," NASA/TM-2018-219931, NASA, Washington DC.
- [66] Karr, D., Vivona, R., and Wing, D. (2013) "Costs of Limiting Route Optimization to Published Waypoints in the Traffic Aware Planner, AIAA-2013-4968, AIAA Guidance, Navigation, and Control Conference, Boston, MA.
- [67] Underwood, M., Cotton, W., Haynes, M., Maris, J., and Wing, D. (2019) "Concept for Intelligent User-Preferred Routes using Digital Data Communication," draft in development for publication as a NASA Technical Memorandum, NASA, Hampton, VA.
- [68] Mertens, C., Wilson, J., Blattmig, S., Solomon, S., Wiltberger, M., Kunches, J., Kress, B., and Murray, J. (2007) "Space Weather Nowcasting of Atmospheric Ionizing Radiation for Aviation Safety," AIAA-2007-1104, 45th AIAA Aerospace Sciences Meeting and Exhibit, Reno, NV.
- [69] Cotton, W. and Wing, D. (2018) "Airborne Trajectory Management for Urban Air Mobility," AIAA-2018-3674, AIAA Aviation Technology, Integration, and Operations Conference, Atlanta, GA.



REPORT DOCUMENTATION PAGE				Form Approved OMB No. 0704-0188	
<p>The public reporting burden for this collection of information is estimated to average 1 hour per response, including the time for reviewing instructions, searching existing data sources, gathering and maintaining the data needed, and completing and reviewing the collection of information. Send comments regarding this burden estimate or any other aspect of this collection of information, including suggestions for reducing this burden, to Department of Defense, Washington Headquarters Services, Directorate for Information Operations and Reports (0704-0188), 1215 Jefferson Davis Highway, Suite 1204, Arlington, VA 22202-4302. Respondents should be aware that notwithstanding any other provision of law, no person shall be subject to any penalty for failing to comply with a collection of information if it does not display a currently valid OMB control number.</p> <p>PLEASE DO NOT RETURN YOUR FORM TO THE ABOVE ADDRESS.</p>					
1. REPORT DATE (DD-MM-YYYY) 01-12-2019		2. REPORT TYPE Technical Publication		3. DATES COVERED (From - To)	
4. TITLE AND SUBTITLE The TASAR Project: Launching Aviation on an Optimized Route Toward Aircraft Autonomy				5a. CONTRACT NUMBER	
				5b. GRANT NUMBER	
				5c. PROGRAM ELEMENT NUMBER	
6. AUTHOR(S) Wing, David J.				5d. PROJECT NUMBER	
				5e. TASK NUMBER	
				5f. WORK UNIT NUMBER 432938.11.01.07.43.40.18	
7. PERFORMING ORGANIZATION NAME(S) AND ADDRESS(ES) NASA Langley Research Center Hampton, Virginia 23681-2199				8. PERFORMING ORGANIZATION REPORT NUMBER L-21088	
9. SPONSORING/MONITORING AGENCY NAME(S) AND ADDRESS(ES) National Aeronautics and Space Administration Washington, DC 20546-0001				10. SPONSOR/MONITOR'S ACRONYM(S) NASA	
				11. SPONSOR/MONITOR'S REPORT NUMBER(S) NASA-TP-2019-220432	
12. DISTRIBUTION/AVAILABILITY STATEMENT Unclassified-Unlimited Subject Category 03 Availability: NASA STI Program (757) 864-9658					
13. SUPPLEMENTARY NOTES					
14. ABSTRACT The Traffic Aware Strategic Aircrew Request (TASAR) concept applies onboard automation for the purpose of advising the pilot of route modifications that would be beneficial to the flight. Leveraging onboard computing platforms with connectivity to avionics and diverse data sources on and off the aircraft, TASAR introduces a new, powerful capability for in-flight trajectory management to the cockpit and its flight crew that is anticipated to induce a significant culture change in airspace operations. Flight crews empowered by TASAR and its derivative technologies could transform from today's flight plan followers to proactive trajectory managers, taking an initial critical step towards increasing autonomy in the airspace system. TASAR was developed as a catalyst for operational autonomy, a future vision where the responsibilities and authorities of trajectory management reside with the aircraft operator and are distributed among participating aircraft, thus fulfilling a vision dating back decades and enabling a fully scalable airspace system. This NASA Technical Paper maps TASAR to its foundational vision and traces its research and development from initial concept generation to an operational evaluation by a U.S. airline in revenue service, the final stage before technology transfer and commercialization.					
15. SUBJECT TERMS TAP; TASAR; airspace; automation; autonomy; operations; optimization; traffic					
16. SECURITY CLASSIFICATION OF:			17. LIMITATION OF ABSTRACT	18. NUMBER OF PAGES	19a. NAME OF RESPONSIBLE PERSON
a. REPORT	b. ABSTRACT	c. THIS PAGE			STI Help Desk (email: help@sti.nasa.gov)
U	U	U	UU	163	19b. TELEPHONE NUMBER (Include area code) (757) 864-9658