

OPTIMIZING THE MODEL OF THE VIKING-400 UAS

Evan W. J. Wandrocke¹, Megan C. Beaulieu², Samuel Zuniga^{3,4}, Aaron M. Mazzulla³, Sally A. Cahill³

¹California State University, Sacramento; ²Rensselaer Polytechnic Institute; ³NASA Ames Research Center; ⁴Millennium Engineering & Integration Co.

BACKGROUND

The SIERRA-B unmanned aircraft system (UAS) is currently used to carry payloads of scientific instruments up to 100 pounds at altitudes up to 13,000 feet for 6-8 hours. SIERRA-B is currently integrating two payloads for flight testing. While SIERRA-B is a unique aircraft at NASA, a similar aircraft, the Viking 400, airframe is available and could be used to support future payloads and enhance the project's mission. This summer project aims to assist with editing and updating the CAD model of Viking 400 in order to expedite the process of making it available to NASA and other researchers.

VIKING-400



BEFORE

Left: a sample of the lack of organization and incomprehensible naming of parts
Right: a hatch over the center wing that did not match the one on the aircraft

- 1intowerwirecradle prt
- 2intowerwirecradle prt
- 005-2073 prt
- 005-2081 prt
- 005-2114 prt
- 005-2115 prt
- 005-2138-001 prt
- 005-3112 prt
- 005-3113 prt
- 005-3114 prt
- 005-3142 prt
- 006-4720-000 prt
- 006-4725-000 prt
- 006-4726-000 prt
- 006-4745-001 prt
- 401-0152-002 prt
- 401-0167-002 prt
- 401-0198-001 prt
- 401-0198-001 prt
- 406-0048-001 prt
- 409-0047-001 prt
- 602-0113-001 prt
- Alt_LandingGear prt
- afhorizontalstructure prt

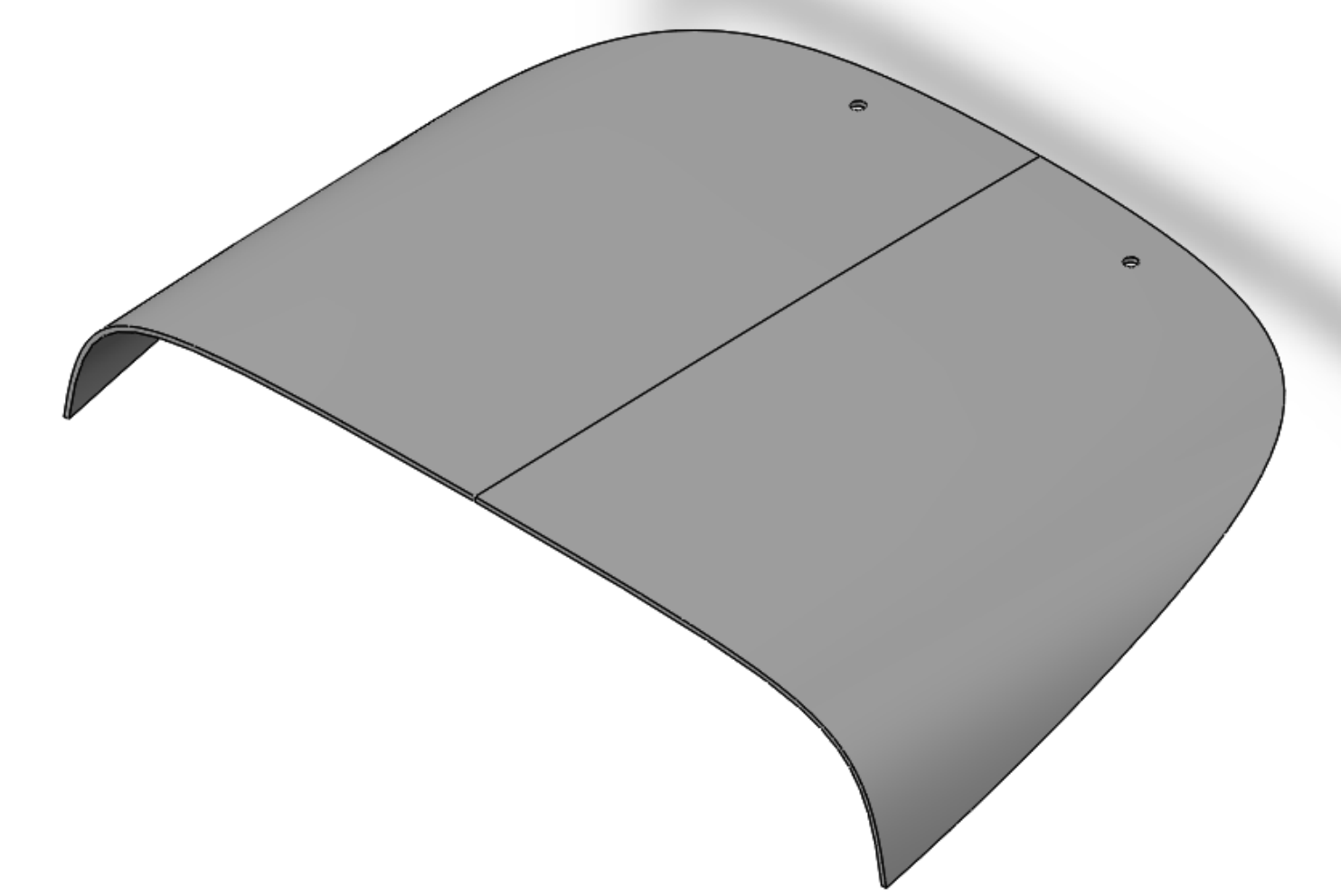

DESIGN DRAWING

This drawing was created using the original CAD model. Actual dimensions were obtained from measuring the actual aircraft, and any discrepancies between the measurements and dimensions in the CAD model are noted on the drawing.

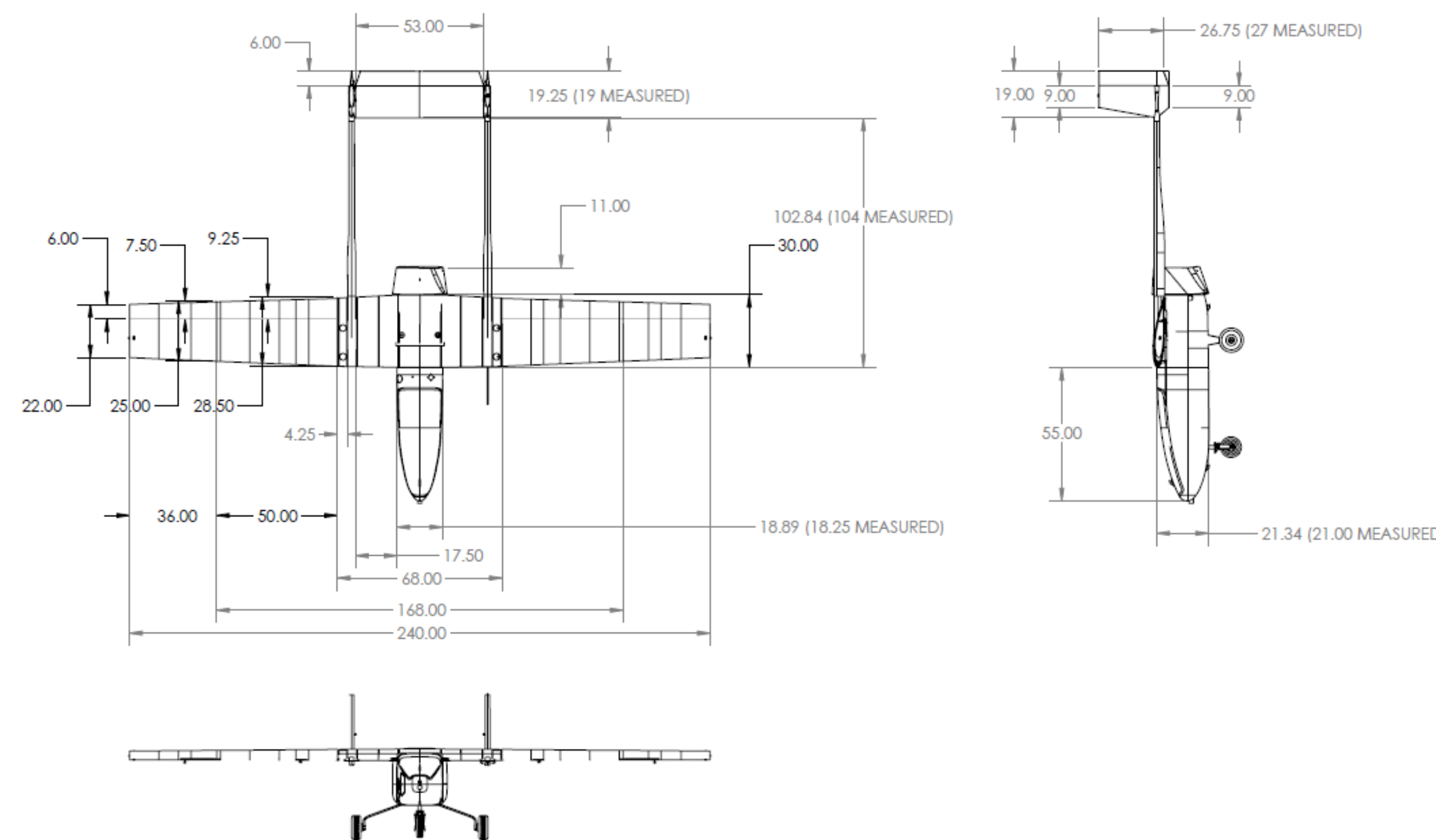

EXECUTION

The original CAD model for the Viking 400 had been scanned into a point-cloud format and imported into a CAD program, where edits and modifications were made. Conversion to Solidworks led to various issues with the model, including an inability to edit some of the parts, several missing features, and a number of features that could not be translated accurately between the modeling programs. The files had also lost any organizational structure they may have had before conversion to Solidworks, making them very difficult to parse through and understand. To resolve these issues, many of the parts had to be redesigned entirely, several parts were edited to better represent the existing physical aircraft, and an organizational structure was devised. Additionally, those parts that were missing had to be located in the maze of a file directory, or they had to be created from scratch. The end result is a model of the aircraft that can be modified for the accommodation of various payloads for future use.

AFTER

Left: a sample of the revised organizational structure of the remodeled aircraft
Right: the redesigned, accurate representation of the center wing hatch

- Viking 400 Final Model
- Empennage-050
- Fuselage-010
 - Forward Gear - 012
 - Main Gear - 013
 - Rail System - 011
- Wings-30
 - Center Wing - 033
 - Center Wing Fasteners
 - Pitot Tube - 330
 - Left Wing - 031
 - Left Wing Control - 310
 - Left Wing Fasteners
 - Left Wing Flap - 311
 - Left Wing LEDs - 312
 - Right Wing Assembly - 032
 - Right Wing Control - 320
 - Right Wing Fasteners
 - Right Wing Flap - 321
 - Right Wing LEDs - 322

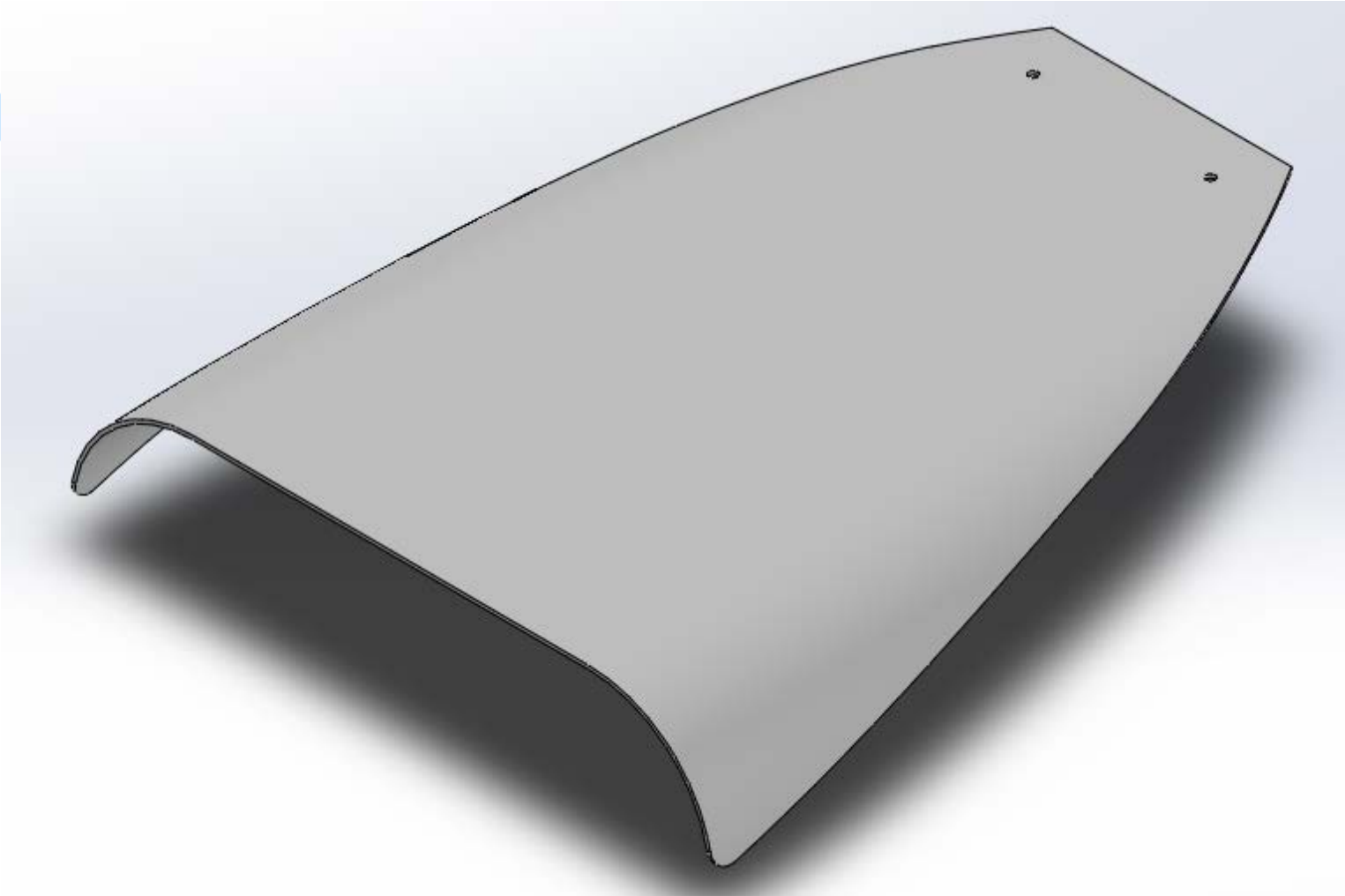

ACKNOWLEDGEMENTS

We would like to thank our mentors, Sally Cahill and Aaron Mazzulla, as well as Samuel Zuniga, Richard Kolyer, Tom Lynn, Michael Irish, and Dave Satterfield for their support and guidance throughout our internship.