

Journal of Engineering Science and Technology
Vol. 7, No. 6 (2012) 722 - 731
© School of Engineering, Taylor's University

ESTABLISHING EMPIRICAL RELATION TO PREDICT TEMPERATURE DIFFERENCE OF VORTEX TUBE USING RESPONSE SURFACE METHODOLOGY

PRABAKARAN J.^{1,*}, VAIDYANATHAN S.², KANAGARAJAN D.³

^{1,2}Department of Mechanical Engineering,

³Department of Manufacturing Engineering,
Annamalai University, Annamalai Nagar, 608002 India

*Corresponding Author: jp_au@yahoo.com

Abstract

Vortex tube is a device that produces cold and hot air simultaneously from the source of compressed air. In this work an attempt has been made to investigate the effect of three controllable input variables namely diameter of the orifices, diameter of the nozzles and inlet pressure over the temperature difference in the cold side as output using Response Surface Methodology (RSM). Experiments are conducted using central composite design with three factors at three levels. The influence of vital parameters and interaction among these are investigated using analysis of variance (ANOVA). The proposed mathematical model in this study has proven to fit and in line with experimental values with a 95% confidence interval. It is found that the inlet pressure and diameter of nozzle are significant factors that affect the performance of vortex tube.

Keywords: Vortex tube, Orifice, Nozzle, Cooling, Energy separation.

1. Introduction

Vortex tube is a mechanical device operating as a refrigerating and heating machine simultaneously without any moving parts, by separating compressed air into low temperature region and high temperature region. The construction details of a vortex tube are shown in Fig. 1. The main parts of vortex tubes are tangential nozzle, vortex chamber, cold orifice and conical valve. When high pressure air enters to the vortex chamber through one or more tangential nozzles a strong vortex flow created which splits in to two regions. The high temperature air near the boundary of the tube leaves circumferentially through the conical valve where as the air at lower temperature leaves through the cold orifice. The main factors

Nomenclatures

DN	Diameter of nozzle, mm
DO	Diameter of orifice, mm
dTc	Temperature difference ($T_{\text{INLET}} - T_{\text{COLD}}$), K
F	'F' test value
MS	Mean sum of squares
P	Inlet pressure, bar
p	Probability
SS	Sum of squares

that influence the performance of vortex tubes are inlet pressure, diameter of orifice, diameter of nozzle, length to diameter (L/D) ratio and cold mass fraction. Figure 2 shows the energy separation in the vortex tube.

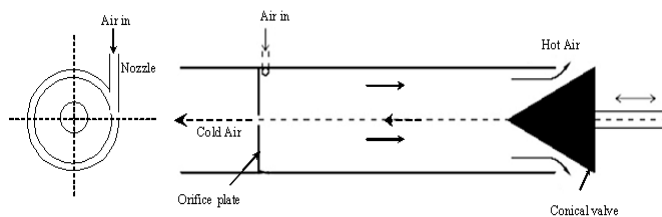

Fig. 1. Construction of Vortex Tube.

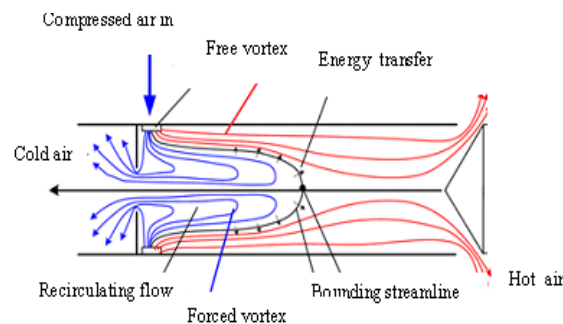

Fig. 2. Energy Separation in Vortex Tube.

Vortex tube was discovered by Ranque [1] in 1933, later developed by Hilsch [2]. Analytical study on the vortex tube was carried out by Lay [3]. Hartnet and Eckert [4] investigated with large size vortex tubes having eight nozzles. Saidi and Valipour [5] classified the parameters that affect the performance of vortex tube as thermo physical parameters and geometry parameters. Gao [6] suggested that the entry to hot end needs more attention. Sing et al. [7] studied the vortex tube with different L/D ratios and suggest that L/D ratio more than 45 has no impact. Arjomandi and Xue [8] investigated the effect of hot end plug of vortex tube. Behera et al. [9] and Promvong and Eiamsa [10] and simulated the flow field of vortex tube using computational fluid dynamics (CFD). Dincer et al. [11] and Kocabas et al. [12] used ANN to model the vortex tube.

Many research works attempt to improve the performance of the vortex tube by changing the geometric parameters. But very few works based on standard statistical methods have been reported. Soni and Thomson [13] used Evolutionary

Operation of Processes (EVOP) method to design the vortex tube and proposed the relations for design of vortex tube. Pinar et al. [14] used Taguchi method to optimize the performance of vortex tube and reported that, vortex tube with two nozzles and Argon gas as working fluid gives the maximum temperature gradient. Response surface methodology (RSM) is widely used to solve the optimization problem in manufacturing environment [15-17]. Rajkumar et al. [16] used RSM to develop the empirical relationships to predict the grain size and tensile strength of friction stir welded AA6061-T6 aluminium alloy joints.

The objective of this paper is to present the empirical relation for the analysis of the effect of input parameters that influence the temperature difference (dT_c) using the response surface methodology (RSM). MINITAB software is used for this investigation.

2. Experimental Procedure

The specifications of the vortex tube used for investigation are shown in Table 1.

Table 1. Specification of the Vortex Tube.

<i>L/D</i> ratio	15
Diameter of vortex tube	12 mm
No of nozzles	1
Diameter of nozzle	2, 3, and 4 mm
Diameter of Orifice	5, 6, and 7 mm
Material	Stainless steel
Angle of conical valve	60°

A thermally insulated Vortex tube with L/D ratio of 15 is fabricated in the laboratory. Three different nozzles and orifices are used for the experiment to investigate the performance of vortex tube. During the experiments the conical valve is kept at fully opened position. The inlet flow rate is varied from 0.1 m³/min to 0.25 m³/min. Figure 3 shows the schematic diagram of experimental setup. The compressed air enters the vortex tube after passing through the pressure regulator and filter. The inlet volume flow rate and cold air flow rate are measured using rotameter with an accuracy of $\pm 2\%$ of full scale. The temperatures of the inlet air, cold air and hot air are measured with T type thermocouples with an accuracy of $\pm 0.1^\circ\text{C}$.

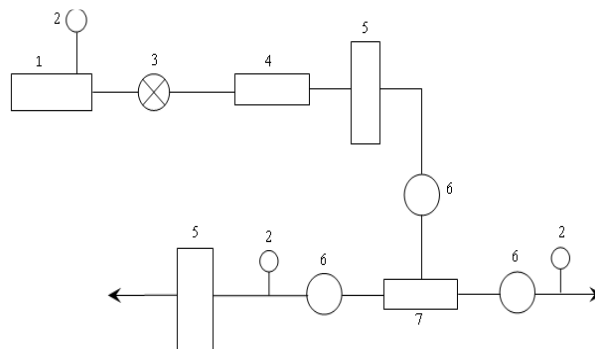

1. Air receiver. 2. Receiver pressure gauge. 3. Control valve.
4. Pressure regulator and filter 5. Rotameter. 6. Thermo couple. 7. Vortex tube.

Fig. 3. Experimental Setup.

3. Response Surface Methodology (RSM)

Response surface Methodology is a collection of statistical and mathematical techniques useful for developing, improving and optimizing the process parameters. The RSM can be used when many input variables potentially influence few performance measure or quality characteristics of the process. Thus the performance measure is called as response. The input variables are called independent variables.

In general, the relationship is

$$Y = f(X_1 + X_2 + X_3 + \dots) \pm \varepsilon \quad (1)$$

where y is the performance measure, X_1, X_2, X_3, \dots are input variables and ε is measurement error. In many cases either First order or Second order model is used. The first order is used when approximating the true response surface over a relatively small region of independent variables.

If the response can be modelled by a linear function of the independent variables, the model can be written as

$$Y = C_0 + C_1X_1 + C_2X_2 + C_3X_3 + \dots C_nX_n \pm \varepsilon \quad (2)$$

If a curvature appears in the system and interaction effects are also considered then a higher degree polynomial can be written as

$$Y = C_0 + \sum_{i=1}^n C_i X_i + \sum_{i=1}^n C_{ii} X_i^2 + \sum_{i < j}^n C_{ij} X_i X_j \pm \varepsilon \quad (3)$$

where C_0 is a constant, C_i , C_{ii} and C_{ij} represent the coefficients of linear, quadratic and cross product terms. The objective of using the RSM is not only to investigate the response over the entire factor space, but also to locate the region of interest where the response reaches its optimum or near optimum value. The process sequence of response surface methodology is shown in the Fig. 4.

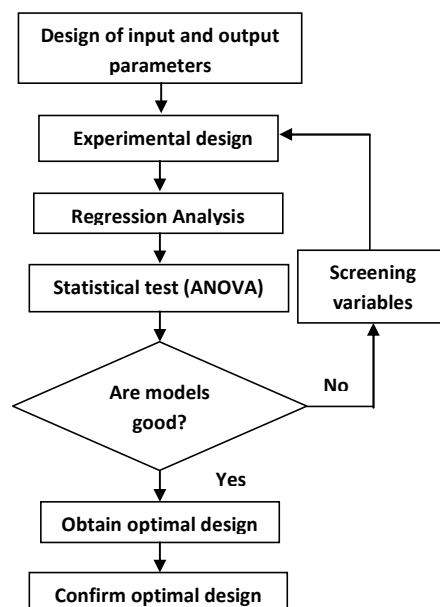

Fig. 4. Process Sequence of Response Surface Methodology.

Development of model based on RSM

Central composite rotatable design of second order was found to be the most efficient tool in RSM to establish the mathematical relation using the smallest possible number of experiments without losing accuracy [17]. Due to small range of factors, it was decided to use three factor three level central composite design matrix. For the convenience of recording and processing experimental data, upper and lower levels of the factors are coded as ± 1 and intermediate level as 0. The process parameters and their levels are shown in Table 2. The experimental design matrix with coded factors and actual factors were shown in Table 3.

$$dTc = -12.005 + 11.3714 P - 11.6255 DO + 25.2973 DN - 1.3045 P^2 + 0.8455 DO^2 - 4.405 DN^2 + 0.0750 P \cdot DO - 0.0250 P \cdot DN + 0.2 DO \cdot DN \quad (4)$$

After knowing the values of the observed response, the values of different regression coefficients of second order polynomial equation were determined. The ANOVA for dTc and the values of coefficient for each term are shown in Tables 4 and 5. The empirical relationship for correlating the temperature difference (dTc) is obtained as follows.

Table 2. Process Parameters and Their Levels.

Parameters		Level		
		-1	0	+1
Inlet pressure ,(P)	in bar	3	4	5
Diameter of orifice, (DO)	in mm	5	6	7
Diameter of nozzle,(DN)	in mm	2	3	4

Table 3. Experimental Design Matrix.

S. No.	Coded factors			Actual factors		
	P	DO	DN	P	DO	DN
1	0	0	0	4	6	3
2	1	1	1	5	7	4
3	0	0	0	4	6	3
4	0	0	0	4	6	3
5	-1	1	1	3	7	4
6	0	1	0	4	7	3
7	-1	0	0	3	6	3
8	0	0	0	4	6	3
9	-1	-1	1	3	5	4
10	-1	-1	-1	3	5	2
11	0	0	-1	4	6	2
12	0	0	1	4	6	4
13	0	0	0	4	6	3
14	1	0	0	5	6	3
15	-1	1	-1	3	7	2
16	0	0	1	4	5	4
17	0	-1	0	4	5	3
18	1	-1	-1	5	5	2
19	1	1	-1	5	7	2
20	1	-1	1	5	5	4

Table 4. Analysis of Variance (ANOVA) for dTc.

Source	DF	SS	MS	F	<i>p</i>
Regression	9	135.502	15.0558	21.64	0.001
Linear	3	20.534	14.9086	21.43	0.002
Square	3	114.598	38.1994	54.92	0.000
Interaction	3	0.370	0.1233	0.18	0.909
Residual error	10	6.956	0.6956		
Lack of fit	5	0.033	0.0067	0.004	0.999
Pure error	5	6.922			
Total	19	142.458			

Table 5. Results of the Analysis of Variance for Each Term.

Term	Co-eff	SE Co-eff	<i>p</i>
Constant	-12.0055	17.4997	0.508
P	11.3714	4.4911	0.030
DO	-11.6255	6.212	0.091
DN	25.2973	3.7009	0.001
P ²	-1.3045	0.5029	0.027
DO ²	0.8455	0.5029	0.124
DN ²	-4.4045	0.5029	0.000
P × DO	0.0750	0.2949	0.804
DO × DN	0.2000	0.2949	0.513
P × DN.	-0.0250	0.2949	0.934

4. Results and Discussion

Figure 5 is the plot between the normal probability and residual error indicates that the errors in the experiments are normally distributed. The empirical relation was proposed for the response variable dTc, and evaluated by the F-Test of ANOVA as shown in Table 4. The fit summary reveals that the fitted quadratic model is statistically significant to analyze the value of dTc. The value of 'p' less than 0.05 (i.e., $\alpha=0.05$, or 95% confidence) indicates that the obtained models are statistically significant. The other important coefficient R^2 , called the determination coefficient is defined as the ratio of the explained variation to the total variation and is measure of degree of fit.

When R^2 approaches unity, the better the response model fits the actual data. For the proposed model the value of coefficient of determination (R^2) is found to be 95.12% and adjusted R^2 statistic (R^2 adj) is 90.72%. This shows that the model for dTc can be regard as significant for fitting and predicting the experimental results. Table 5 shows the values of 'p' for each term on the performance of dTc. The pressure and diameter of the nozzle are found to be significant factors that affect the performance of vortex tube along with the square effect of these factors. Whereas the interaction effect of the input variables are insignificant.

Figure 6 shows the experimental and predicted values of temperature difference. It is observed that the predicted values are closer to the experimental values. The average error between experimental and predicted value is found to be 3.6%.

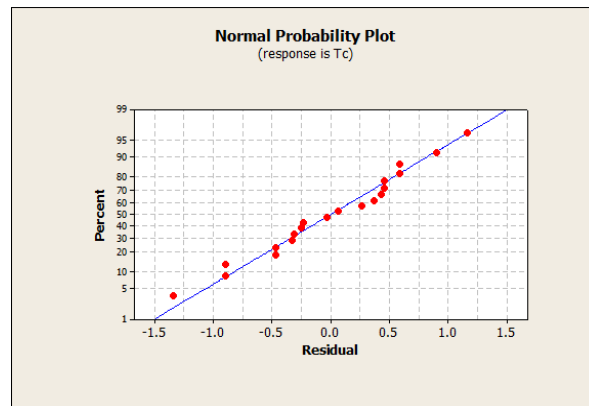

Fig. 5. Normal Probability vs. Residuals.

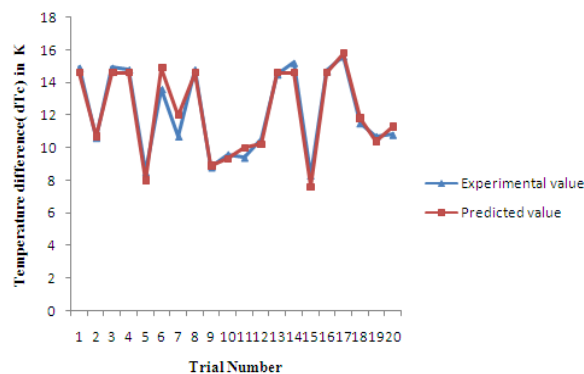

Fig. 6. Experimental Values and Predicted Values of dTc.

Figure 7 shows the effects of pressure and diameter of orifice on dTc. It could be asserted that the optimum pressure is between 4 bar to 5 bar and optimum diameter of orifice is close to 5 mm. As the pressure increases, the temperature difference is also increasing. This indicates that the pressure is the driving force for the temperature difference. When the orifice diameter increases, the temperature difference decreases. Because the tangential velocity of the air will be high near the boundary wall and it will be low towards the centre. When the diameter of the orifice increases, the air near the boundary wall will escape easily through cold end resulting lower energy separation.

The effects of pressure and diameter of nozzle on dTc are depicted in Fig.8. It suggests that the optimum pressure is 3.75 bar to 5 bar and the optimum diameter of nozzle is 2.5 mm to 3.5 mm.

Figure 9 shows the effect of interaction of diameter of orifice and diameter of nozzle. It shows that optimum diameter of orifice is nearly 5mm and the optimum diameter of nozzle is 2.75 mm to 3.25 mm.

The above said graphs indicate that low diameter of nozzle and higher diameter of orifice are affecting the energy separation. For better energy separation the optimum diameter of nozzle should be 3mm for a vortex tube of 12 mm diameter.

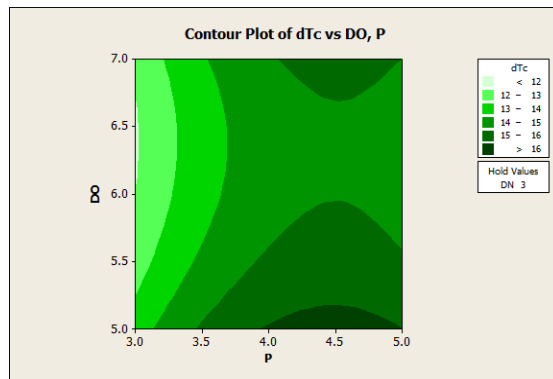

Fig. 7. Effects of Pressure and Diameter of Orifice on dTc.

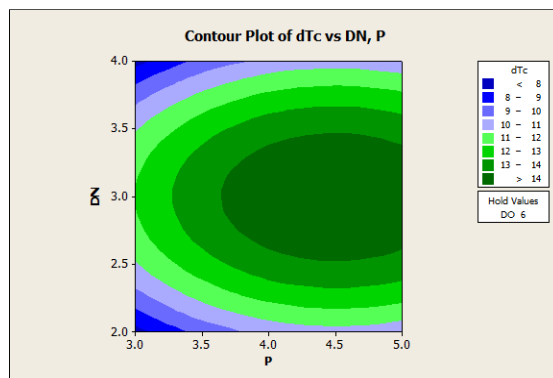

Fig. 8. Effects of Pressure and Diameter of Nozzle on dTc.

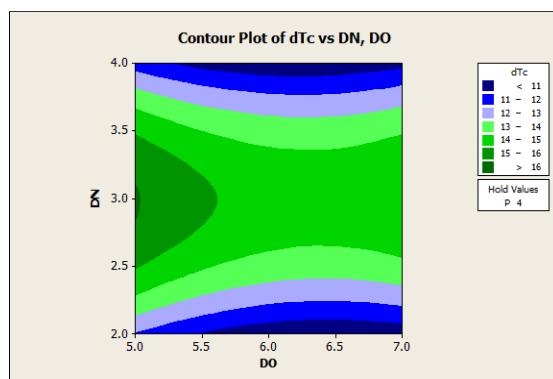

Fig. 9. Effects of Diameter of Nozzle and Diameter of Orifice on dTc.

Confirmation test

The optimization plot (Fig. 10) provides the optimum values for all the input parameters using response optimizer. The optimum values are as follows: optimum diameter of orifice is 5 mm, optimum diameter of nozzle is 2.969 mm, optimum pressure is 4.474 bar and the maximum temperature difference (dTc) predicted is 16.368°.

To validate the parametric values obtained, an experiment was conducted with an orifice of 5 mm diameter and nozzle of 3mm diameter at a pressure of 4.5 bar which yielded the temperature difference of 15.9° which is higher than all the experimental values. This confirms that the proposed model is proved to be good enough to predict the temperature difference of counter flow vortex tube.

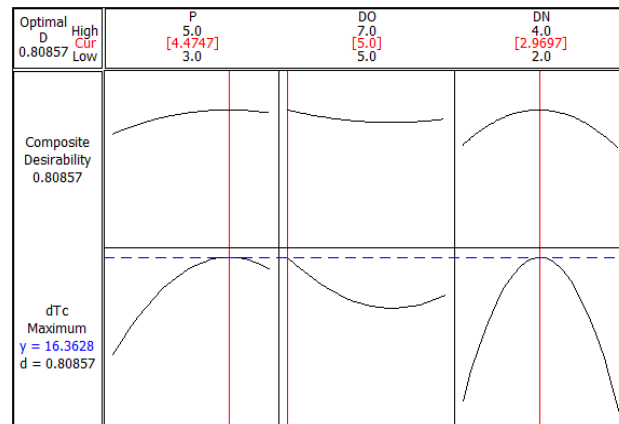

Fig. 10. Optimization Plot.

5. Conclusions

An experimental plan of central composite design based on RSM was employed to carry out experimental study. Empirical relation for temperature difference (dTc) was obtained to correlate dominant input parameters, including diameter of orifice, diameter of nozzle and pressure using Response Surface Methodology. The influence of input parameters on the performance of vortex tube was analyzed based on the developed relation to yield the following conclusions.

- The results of ANOVA show that the proposed model for dTc fairly fits with experimental values with a 95 % confidence interval.
- The significant factors affecting the performance of vortex tubes are pressure and diameter of nozzle.
- The optimum diameter of nozzle is 2.969 mm
- The optimum diameter of orifice is 5 mm
- The optimum pressure is 4.474 bar
- The maximum temperature difference (dTc) is 15.9° .

Acknowledgement

The authors thank the authorities of Annamalai University to carry out this research work in the department of Mechanical Engineering.

References

1. Ranque, G.J. (1933) Experiments on expansion in vortex with simultaneous exhaust of hot air and cold air. *Le Journal de Physique et le Radium (Paris)*, 4, 112-114.

2. Hilsch, R. (1947). The use of expansion gases in centrifugal field as a cooling process. *Review of Scientific Instruments*, 18(2), 108-113.
3. Lay, J.E. (1959). An experimental and analytical study of vortex flow and temperature separation by superposition of spiral and axial flow, part 1 & part 2. *Transactions of ASME: Journal of Heat Transfer*, 81(3), 202-222.
4. Hartnet, J.P.; and Eckert, E.R.G. (1957). Experimental study of velocity and temperature distribution in high velocity vortex tube flow. *Transactions of ASME: Journal of Heat Transfer*, 79, 751-758.
5. Saidi, M.H.; and Valipour, M. (2003). Experimental modeling of vortex tube refrigerator. *Applied Thermal Engineering*, 23(15),1971-1980
6. Gao, C.M.; Bosschart, K.J.; Zeegers, J.C.H.; de Waele, A.T.A.M. (2005) Experimental study on a simple Ranque-Hilsch vortex tube. *Cryogenics*. 45(3), 173-183.
7. Singh, P.K.; Tathgir, R.G.; Gangacharyulu, D.; and Grewal, G.S. (2004). An experimental performance evaluation of vortex tube. *IE(I) Journal*, 84,149-153.
8. Arjomandi, M.; and Xue, Y. (2007). An investigation of the effect of the hot end plugs on the efficiency of Ranque-Hilsch vortex tube. *Journal of Engineering Science and Technology (JESTEC)*, 2(3), 211-217
9. Behera, U.; Paul, P.J.; Kasturirangan, S.; Karunanithi, R.; Ram, S.N.; and Jacob, D.S. (2005). CFD analysis and experimental investigation towards the optimizing the parameter of Ranque-Hilsch vortex tube. *International Journal of Heat and Mass Transfer*, 48(10), 1961-1973.
10. Promvong, P.; and Eiasma-ard, S. (2005). Investigation on the vortex thermal separation in a vortex tube refrigerator. *ScienceAsia*, 31(3), 215-223
11. Dincer, K.; Baskaya, S.; and Uysal, B.Z. (2008) Experimental investigation of the effects of length to diameter ratio and nozzle number on the performance of counter flow vortex tube. *Heat and Mass Transfer*, 44(3), 367-373.
12. Kocabas, F.; Korkmaz, M.; Sorgucu, U.; and Donmez, S. (2010). Modeling of heating and cooling performance of counterflow vortex tube by using artificial neural network. *International Journal of Refrigeration*, 33(5), 963-972.
13. Soni, Y.; and Thomson, W.J. (1975). Optimal design of Ranque-Hilsch vortex tube. *ASME Journal of Heat transfer*, 97(2), 316-317.
14. Pinar, A.M.; Uluer, O.; and Kirmachi, V. (2009). Optimization of counter flow Ranque-Hilsch vortex tube performance using Taguchi method. *International Journal of Refrigeration*, 32(6), 1487-1494.
15. Chiang, K.-T. (2008). Modeling and analysis of the effects of machining parameters on the performance characteristics in the EDM process of Al₂O₃+TiC mixed ceramic. *International Journal of Advanced Manufacturing Technology*, 37(5-6), 523-533.
16. Rajkumar, S.; Muralidharan, C.; and Balasubramanian, V. (2010). Establishing empirical relationships to predict the grain size and tensile strength of friction stir welded AA6061-T6 aluminium alloy joints. *Transactions of Nonferrous Metals Society of China*, 20(10), 1863-1872.
17. Gunaraj, V.; and Murugan, N. (1999), Application of response surface methodology for predicting weld bead quality in submerged arc welding of pipes. *Journal of Materials Processing Technology*, 88(1-3), 266-275.