

UDK 666.655;535.242.65;519.224

Metal Rings and Discs Matlab/Simulink 3D Model for Ultrasonic Sandwich Transducer Design

I. Jovanović^{1*)}, D. Mančić¹, V. Paunović¹, M. Radmanović¹, V. V. Mitić^{1,2}¹University of Niš, Faculty of Electronic Engineering, Aleksandra Medvedeva 14, Niš, Serbia²Institute of Technical Sciences of SASA, Belgrade, Serbia

Abstract:

Metal-endings are integral part of different ultrasonic sandwich transducers. In this paper a new Matlab/Simulink 3D model of of the finite metal rings and discs of various dimensions is realized. With this model, which describes both the thickness and the radial resonant modes, and the coupling between them, mechanical impedance of the sample can be easily computed. Resonance frequency-length curves for rings and disks with various materials and for different selected dimensions are given. Also, comparisons of the different approaches in determining of their resonant frequencies are shown. The proposed Matlab/Simulink model requires simpler implementation than other analytical models. That enabled modifying of 1D theory and simplified modelling and projecting of the ultrasonic sandwich transducers with short-endings. Finally, the computed and experimental results are compared.

Keywords: *Metal ring/disc, Matlab/Simulink model, Resonance frequency characteristics, Frequency spectrum.*

1. Introduction

Metal rings and discs, in along with piezoceramic rings and metal bolt, are the main constituents of power ultrasonic sandwich transducers. For precise design of such complex resonant structure is necessary to know its own resonant frequency of all these components of ultrasonic transducers, and especially resonant frequency of metal ending in the form of rings and discs [1, 2].

In ultrasound practice so far, the most often applied to determine the resonant frequency of such structures are numerical methods. The calculation procedures of numerical methods are very slow, and main goal was to find a simpler, but sufficiently accurate, method for determining the resonant frequencies of these metal parts of the transducer [3]. These methods are always implied the introduction of additional approximations in solving three-dimensional problems of linear elasticity, so that the mentioned method is always tied to the metal samples of negligible diameter in relation to their length, and samples of negligible thickness in comparison with their diameter. Thereby is rarely considering the impact of the size of the ring holes to its resonant frequency characteristics.

This paper is an attempt to arrive at a satisfactory model of metal rings and discs, for samples which not have some negligible dimensions, but the patterns that have some minor

*) **Corresponding author:** igor.jovanovic@elfak.ni.ac.rs

dimensions, i.e. samples in which the dimensions in the diameter and the radial direction can be mutually compared. This paper presents a new Matlab/Simulink model with use 3D model of metal rings and discs of finite length, for different values of the inner radius and the length (thickness). Using this model, which describes the thickness and the radial resonant modes of samples which are loaded on all of its boundary surfaces, as well as their mutual coupling, the mechanical impedance of the metal ending can be easily calculated. The proposed model is suitable for the analysis of resonant modes of the samples in a wide frequency range. Curves between the resonant frequency and length are presented for rings and disks of different materials, as well as for different selected dimensions. Compared with numerical methods designing are significantly accelerated. Also a comparison between the calculated and experimental results is shown.

2. Description of Leading Equations

Based on the 3D model of piezoceramic rings presented in [4], proposed model relates to the metal rings whose appearance and dimensions are presented in Fig 1.

As mentioned in the introduction, the proposed model refers to the metal rings that represent the components of the ultrasonic sandwich transducers, although it can be used in the design of metal cylindrical resonators in other areas of their application. Analysis of ultrasonic vibration of metal rings in the literature has not received sufficient attention, like metal cylinders which are already been generally analyzed. The reason for this was that the ultrasonic transducers for the lower resonant frequency with large lengths metal endings are only analyzed, in which the inner diameter of cylinder with a hole does not have great influence in determining the resonant frequency for analysis of the longitudinal oscillation modes. However, the analysis of oscillations of ultrasonic transducers for higher operating resonant frequency, with a short metal rings, which are the subject of this paper, a shape of endings has great influence on the basic resonant frequency. Differences in the frequency spectrum of the metal discs and rings of the same outer diameter and thickness, i.e. the impact of the inner diameter of the rings, will be illustrated using the proposed 3D Matlab/Simulink model of metal rings of finite length. This model is general, because the model of the metal disk or solid cylinder of finite length may be obtained by neglecting hole of the ring.

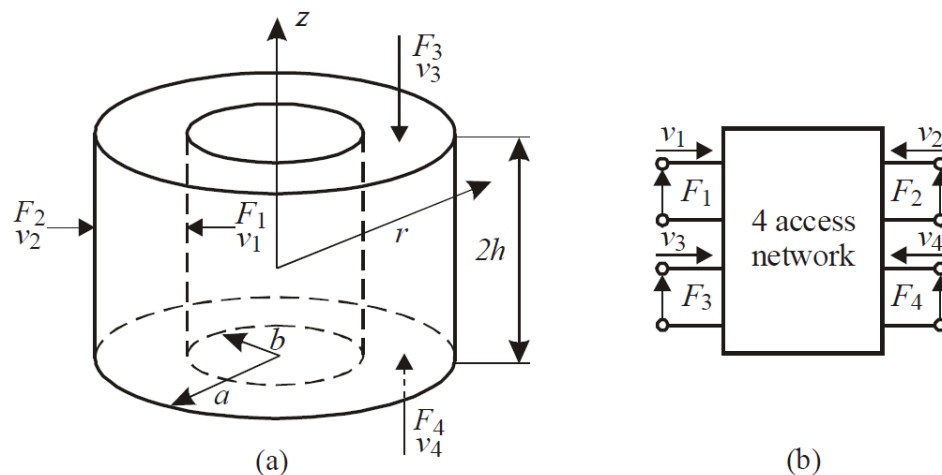

Fig. 1. Loaded metal ring: (a) geometry and dimensions; (b) metal ring as a 4-access network.

Dimensions of the ring and polar-cylindrical coordinate system with origin in the ring centre, are defined in Fig. 1a. Every ring surface is loaded by acoustic impedance Z_i , where v_i and F_i are velocities and forces on those contour surfaces S_i ($i=1, 2, 3, 4$). Where the $F_i = -Z_i v_i$. These metal rings, with the outer diameter a , inner diameter b and thickness (length) $2L$, in power ultrasonic transducers are used as a reflector and emitter endings. It is assumed that the central plane of the ring located at $z=0$, so that its and circular-curved surfaces lying on the $z=\pm L$.

Using this model, metal ring is modeled with electromechanical circuit by 4-access network (Fig. 1b), whereat are F_i and v_i ($i=1, 2, 3, 4$) forces and velocities on outer surfaces of the ring, as in the case of piezoceramic rings. The model is obtained simply, based on the derived model of piezoceramic rings, by neglecting the piezoelectric constants h_{31} and h_{33} in the linear system of equations, using the matrix dimensions of 5×5 describing the behavior of the piezoceramic rings. In this system of equations the electrical values (voltage V and current I) with mechanical values (forces F_i and velocity v_i) are related in the frequency domain, a detailed implementation of these expressions is shown in the literature [5]. Besides that, expressions are simplified in a way that, due to the material isotropy, following relations are adopted for material constants:

$$c_{11} = c_{33} = \lambda_m + 2\mu, \quad c_{12} = c_{13} = \lambda_m, \quad (1)$$

where are λ and μ Lamé's coefficients, and c_{ij} constants of elastic deformation.

With these assumptions, linear equations that connect mechanical values on the external ring surfaces are simpler, and are reduced to the following equation system:

$$\begin{bmatrix} F_1 \\ F_2 \\ F_3 \\ F_4 \end{bmatrix} = \begin{bmatrix} z_{11} & z_{12} & z_{13} & z_{13} \\ z_{21} & z_{22} & z_{23} & z_{23} \\ z_{13} & z_{23} & z_{33} & z_{34} \\ z_{13} & z_{23} & z_{34} & z_{33} \end{bmatrix} \begin{bmatrix} v_1 \\ v_2 \\ v_3 \\ v_4 \end{bmatrix}, \quad (2)$$

where the impedance matrix elements are defined by the following expressions:

$$\begin{aligned} z_{11} &= \frac{-4\pi L}{j\omega} \left\{ c_{12} - c_{11} \left[1 - kb \left(A_1 J_0(kb) + B_1 Y_0(kb) \right) \right] \right\}, \\ z_{22} &= \frac{4\pi L}{j\omega} \left\{ c_{12} - c_{11} \left[1 + ka \left(A_2 J_0(ka) + B_2 Y_0(ka) \right) \right] \right\}, \\ z_{12} &= \frac{-4\pi kbLc_{11}}{j\omega} \left[A_2 J_0(kb) + B_2 Y_0(kb) \right], \\ z_{21} &= \frac{-4\pi kaLc_{11}}{j\omega} \left[A_1 J_0(ka) + B_1 Y_0(ka) \right], \\ z_{13} &= \frac{2\pi bc_{12}}{j\omega}, \quad z_{23} = \frac{2\pi ac_{12}}{j\omega}, \\ z_{33} &= \frac{c_{11} k \pi (a^2 - b^2)}{j\omega \tan(2kL)}, \\ z_{34} &= \frac{c_{11} k \pi (a^2 - b^2)}{j\omega \sin(2kL)}. \end{aligned} \quad (3)$$

In the previous expressions J_i and Y_i are Bessel's functions of first and second rank, order i , respectively; ω is the angular frequency, and $k=\omega/v=2\pi/\lambda$ is the axial wave number (v is the phase velocity of the wave and λ is wavelength).

The values of introduced integration constants A_1 , A_2 , B_1 , and B_2 are:

$$\begin{aligned}
 A_1 &= \frac{Y_1(ka)}{J_1(kb)Y_1(ka) - J_1(ka)Y_1(kb)}, \\
 A_2 &= \frac{Y_1(kb)}{J_1(kb)Y_1(ka) - J_1(ka)Y_1(kb)}, \\
 B_1 &= \frac{J_1(ka)}{J_1(ka)Y_1(kb) - J_1(kb)Y_1(ka)}, \\
 B_2 &= \frac{J_1(kb)}{J_1(ka)Y_1(kb) - J_1(kb)Y_1(ka)}.
 \end{aligned}
 \tag{4}$$

3. Matlab/Simulink Model

Matlab/Simulink is interactive software which has been used recently as design and development environment for model implementation in various areas of engineering and scientific applications [6]. Matlab/Simulink is an environment for multi-domain simulation and model-based design for dynamic and embedded systems. It provides an interactive graphical environment and a customizable set of block libraries. The graphical representation of models in Matlab/Simulink is based on block communication diagrams. Simulink is integrated with Matlab, providing immediate access to an extensive range of tools that let engineer to develop algorithms, analyze and visualize simulations, create batch processing scripts, customize the modeling environment, and define signal, parameter, and test data [4].

This section presents how the mathematical model of the metal ring or disc, described in previous section, is implemented in Matlab/Simulink. As mentioned above, the graphical representation of models is based on block communication diagrams. Internally, the model is split into smaller separate functions blocks. In order to demonstrate the advantages of this process, the Matlab/Simulink model of a metal ring and disc are developed. At this point, it is possible to encapsulate the whole model in a Simulink blocks. A general schematic of this model is presented in Fig. 2.

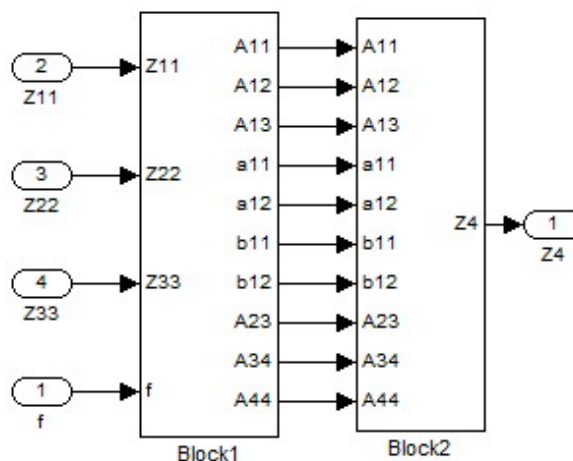

Fig. 2. Matlab/Simulink model of the metal ring or disc.

In the ultrasonic transducers, such a metal ring is connected through one of its circular-ring (flat) surface with piezoceramic ring, and therefore an essential is mechanical input impedance of the metal ring, which is a load to the piezoceramic ring. By introducing

the relation between force and velocity on the external surface via acoustic impedance ($F_i = -Z_i v_i$, $i=1,2,3,4$), and their replacement in the system of Eq. (2), one can determine any mechanical impedance.

Eqs. (1), (2), (3) and (4) fully describe the model of the metal ring, which has been used for the simulation. Realized Matlab/Simulink model consist of two main blocks (Fig. 2). The first block gives all elements of the matrix in Eq. (2) as well as all the required coefficients a customized set of Eq. (5), which has been obtained through a series of simple mathematical operations. Calculating of these elements is based on entered characteristics and dimensions of used metal.

$$\begin{bmatrix} 0 \\ 0 \\ 0 \end{bmatrix} = \begin{bmatrix} A_{11} & A_{12} & A_{13} & A_{14} \\ 0 & a_{11} & a_{12} & a_{13} \\ 0 & 0 & b_{11} & b_{12} \end{bmatrix} \cdot \begin{bmatrix} v_1 / v_4 \\ v_2 / v_4 \\ v_3 / v_4 \\ 1 \end{bmatrix} \quad (5)$$

where are:

$$\begin{aligned} A_{i,j} &= z_{i,j} \quad (i=1,2,3; \quad j=1,2,3,4; \quad i \neq j) \\ A_{i,j} &= z_{i,j} + Z_j \quad (i=1,2,3; \quad j=1,2,3,4; \quad i = j) \\ a_{i,j} &= A_{1,j+1} \cdot A_{i+1,1} - A_{1,1} \cdot A_{i+1,j+1} \quad (i=1,2,3; \quad j=1,2,3,4; \quad i = j) \\ b_{i,j} &= a_{1,j+1} \cdot a_{i+1,1} - a_{1,1} \cdot a_{i+1,j+1} \quad (i=1,2; \quad j=1,2,3) \end{aligned} \quad (6)$$

and Z_j is acoustic impedances that load boundary surfaces of metal ring.

The second part of the model use corresponding value obtained in the first block and solves the system of Eq. (5) and determines all of the needed values for computing mechanical impedance on metal ring surface, Eq. (7).

$$Z_4 = F_4 / v_4 = z_{13} \frac{v_1}{v_4} + z_{23} \frac{v_2}{v_4} + z_{34} \frac{v_3}{v_4} + z_{33} \quad (7)$$

The second block for model of a metal ring is shown in Fig. 3.

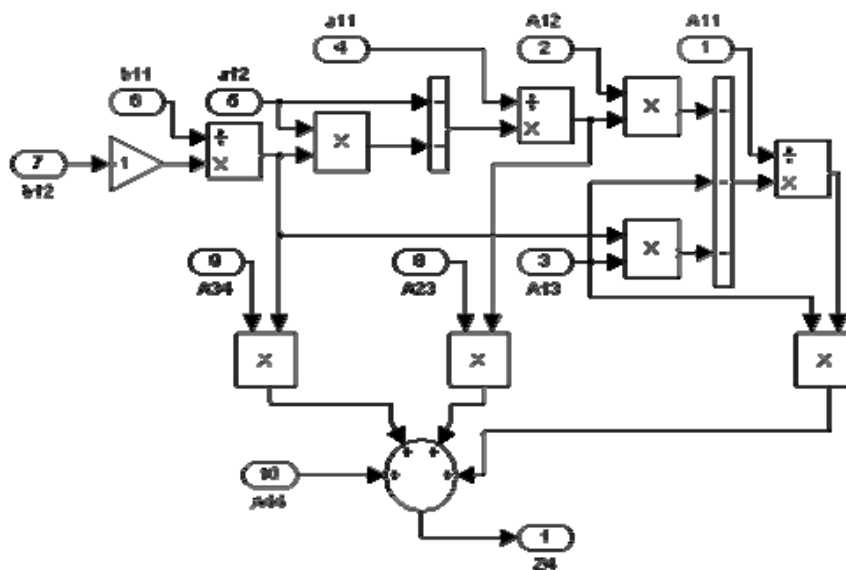

Fig. 3. Matlab/Simulink subsystem (Block2) for determining values for mechanical impedance of metal ring/disc

Another powerful feature of the Matlab/Simulink, called masking, is that it can simplify the use of the model by replacing many dialog boxes in a subsystem with a single dialog box. Instead of requiring the user of the model to open each block and enter metal parameter values, those parameter values can be entered on the mask dialog block and passed to the blocks in the masked subsystem. Fig. 4 illustrates how the mask dialog block for the metal ring looks like. The user has just to change the values of the parameters for different types of metal endings.

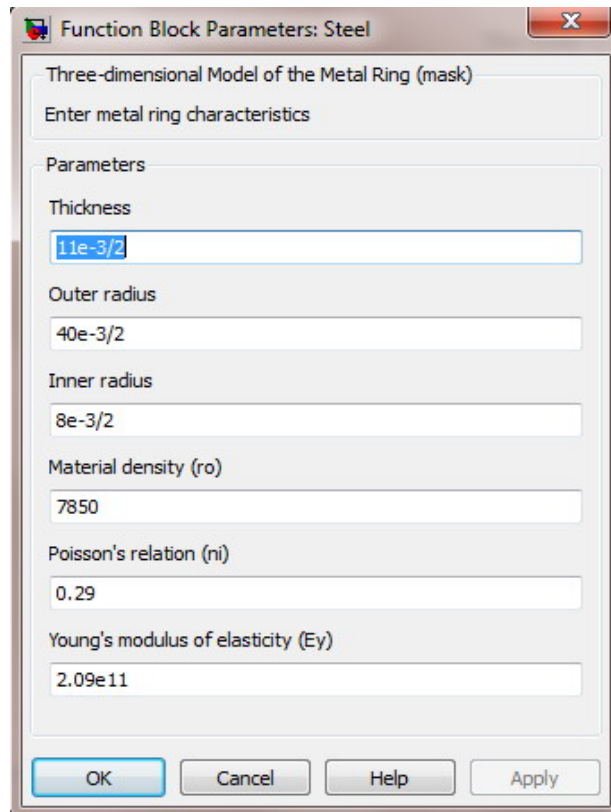

Fig. 4. Mask dialog block for the enter metal ending dimensions and parameters.

Thus development of the Matlab/Simulink model of the metal ring has been completed. The model provides numerous possibilities for the investigation of metal ring properties. Verification of the created Matlab/Simulink model will be considered in the next section.

4. Numerical results

As mentioned above, by introducing the relation between force and velocity on the external surface via acoustic impedance ($F_i = -Z_i v_i$, $i=1,2,3,4$), and their replacement in the system of Eq. (2), one can determine whether the mechanical impedance. Fig. 5 shows the input mechanical impedance $Z_m = F_4/v_4$ for the ring of duralumin with dimensions: $2a=40\text{mm}$, $2b=8\text{mm}$, $2L=18\text{mm}$, and the steel ring of the same outer and inner diameter, with thickness $2L=11\text{mm}$. Metal rings of this size are components of ultrasonic transducers which are operating at a resonant frequency of 40kHz.

For design and optimization of high power ultrasound, dependence the resonant frequency by the dimensions of metal rings shows important properties than the characteristic

shown in Fig. 5, which can also be determined by applying the proposed model. In Fig. 6 are simultaneously presented frequency spectrums for a steel ring and steel disk with same outer diameter, obtained by the proposed model. Thereby is confirmed the statement obtained applying the numerical method that differences in frequency spectrums increase with increase of the inner opening diameter of the ring, which in endmost case generates changes of the resonant frequencies of the ultrasonic sandwich transducers modes.

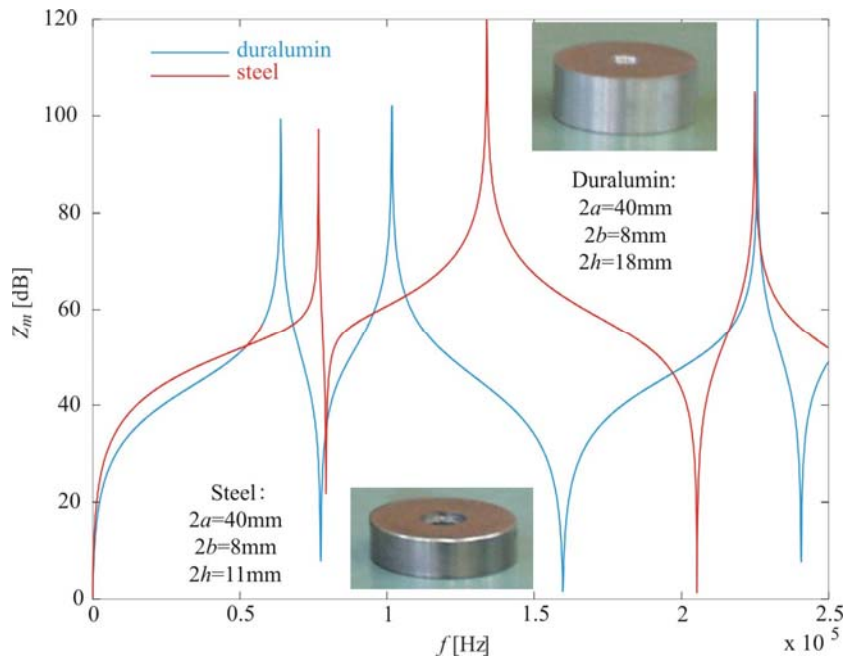

Fig. 5. Simulated input mechanical impedance versus frequency for the dural and steel sample.

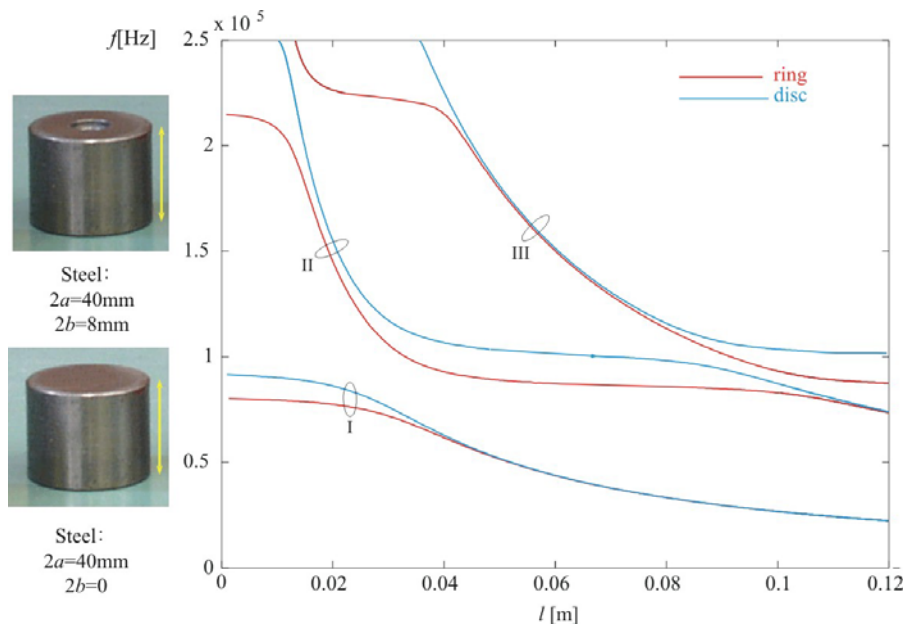

Fig. 6. Frequency spectrum of a steel ring in function of its length and opening dimensions, for the case of a ring $b/a=8/40$ and disk $b/a=0$.

Fig. 6 also shows the frequency spectra of the steel ring and steel disc of the same outer diameter, obtained by the proposed Matlab/Simulink model. This confirmed the conclusion obtained by numerical method [7], the differences in the frequency spectra increases with increasing inner diameter of the ring, which ultimately causes a change of resonant frequency modes of ultrasonic sandwich transducers.

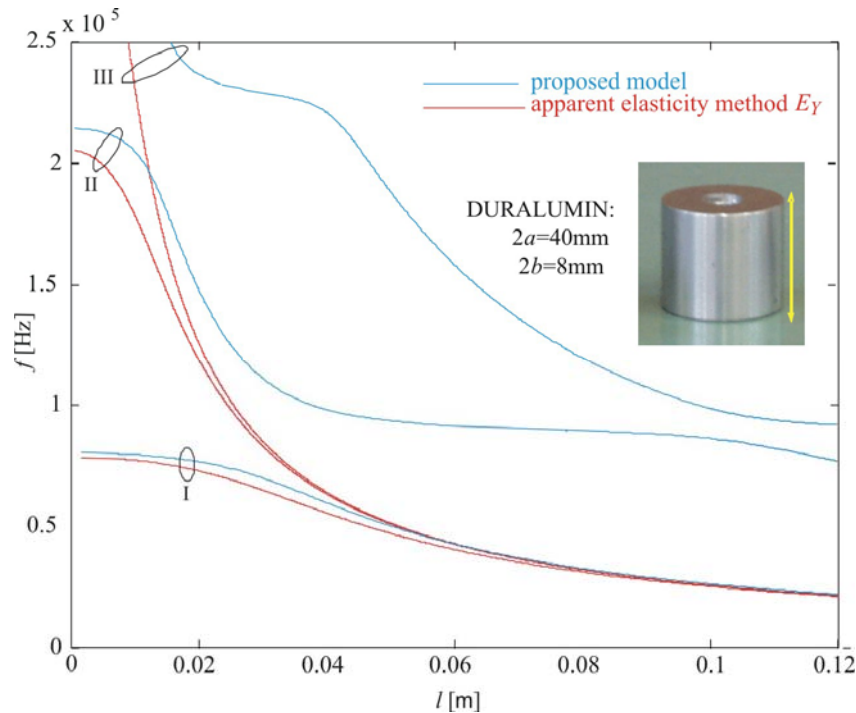

Fig. 7. Frequency spectrum of a duralumin ring with ratio $b/a=8/40$ in function of its length.

In order to present the improvements obtained by quoted modeling approach, in Fig. 7 is also presented the frequency spectrum obtained applying the apparent elasticity method [3]. It is obvious that the first resonant modes for both models almost identical, which was logical to expect, because the apparent elasticity method reduces to determination of the first resonant mode. However, higher resonant modes obtained by the proposed model predict the mode coupling, so the resonant curves are not uniform as in case of application of the apparent elasticity method, which is closer to the real case. The apparent elasticity method represents modification of the 1D line theory, so that its application in equivalent circuits would reduce to a two-access network, with artificially modified line parameters. Thus, one may not realize analyses of oscillation in radial direction that is enabled by the proposed model, especially in complex devices with several serial-parallel connections of the mechanical accesses that exist in the field of power ultrasound.

The conclusion as mentioned above, the dependence of the resonant frequency from the ring length may be even better confirmed based on the Fig. 8. Namely, beside the mentioned conclusion, it is also essential the dependence of the resonant frequency from the ratio of inner and outer ring radius. In Fig. 8 is presented quoted dependence for the case of duralumin ring with thickness of 18mm. In the presented figure, frequencies of the lowest resonant mode decrease with increase of b/a , frequencies of the second resonant mode do not depend much from the inner opening dimension of the ring, while the frequencies of the third and higher resonant modes grow with increase of ratio b/a .

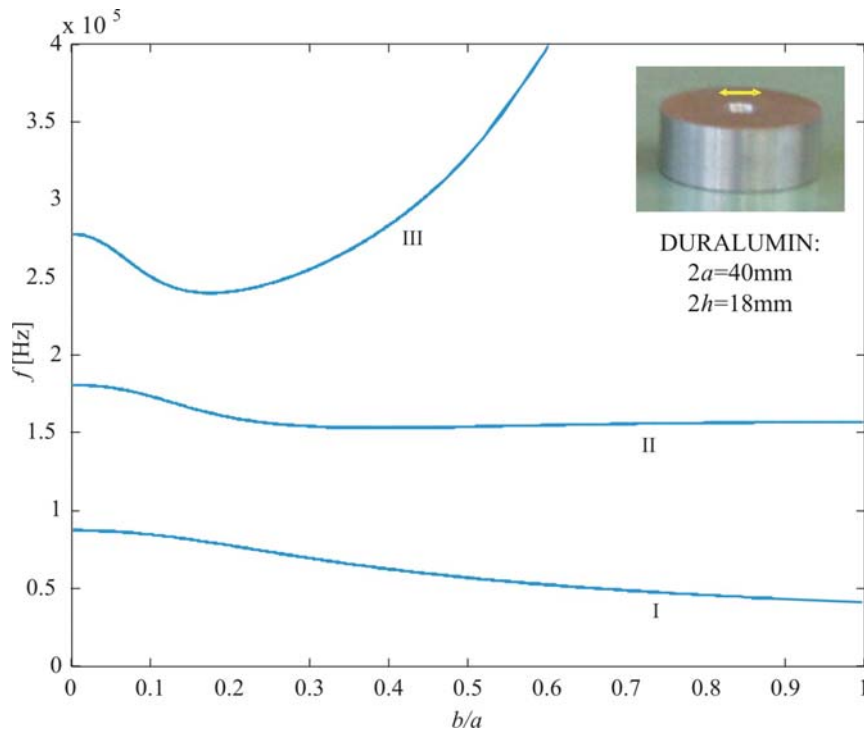

Fig. 8. Frequency spectrum of a duralumin ring with thickness $2h=18\text{mm}$ in function of ratio b/a .

As in case of piezoceramic ring [5], one may here also observe the influence of specific mechanical loads on different surfaces of the metal ring onto the input mechanical impedance and resonant frequency spectrum; however, such analysis for an isolated metal ring is not too interesting. This analysis may be performed in modeling of complete sandwich transducers, when much more interesting is the influence of mechanical load of metal rings, because they will be consisting parts of the complete ultrasonic sandwich transducers.

5. Comparison of Numerical and experimental Results

In order to test the validity of the proposed Simulink model of metal rings, there are experimentally determined resonant frequencies of metal rings and solid cylinders with different dimensions and made of different materials (duralumin and steel). Finally, Fig. 9 and Fig. 10 shows the frequency spectra of only the lowest (first few) resonant modes of different rings and cylinders of duralumin and steel, respectively, using the proposed Matlab/Simulink model. Measurements are performed using vibration platform of the company Herfurth. Material parameters, which are used in modeling (simulation) metal rings, are shown in the literature [7].

Obviously, the proposed Matlab/Simulink model is able to predict the frequency spectra of metal rings of any size, and to an accuracy of no less than in the case of application of numerical methods [7]. So, we kept the high accuracy in determining the resonant frequency, and more importantly than that are obtained ability to determining the different transfer functions of loaded metal ring. Getting good results in the case of analysis unloaded metal rings is justification for using this model in the case of loaded rings, when modeling the complete ultrasonic sandwich transducers.

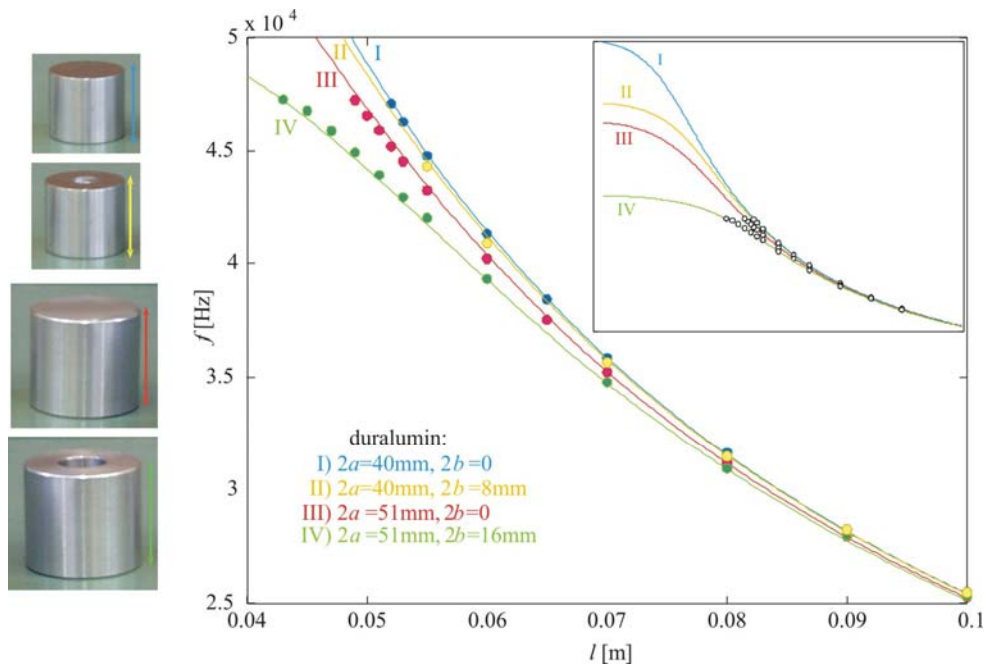

Fig. 9. Simulated frequency spectrum for duralumin ending parts for first resonance frequencies.

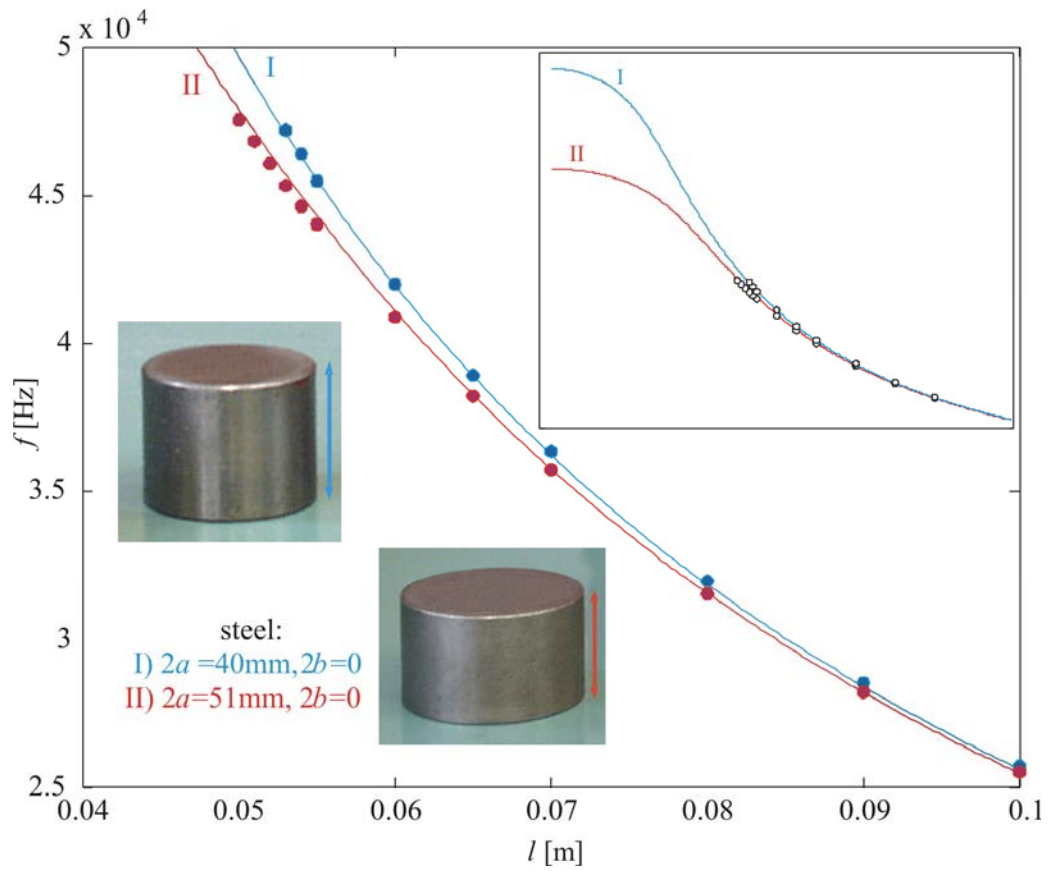

Fig. 10. Simulated frequency spectrum for steel ending parts for first resonance frequencies.

6. Conclusion

Modeling of the power ultrasonic transducers is conditioned by the development of suitable models piezoceramic rings and discs, and, in parallel with this, by the development of models of metal endings of the transducers with same or similar shape.

This paper presents a new approach to modeling a metal ending in a ring, disk or cylinder shape. In this paper an accurate metal ring model valid to any diameter to thickness ratio is realized and demonstrated in Matlab/Simulink. This model taking the interaction with the surrounding media into account is able to compute all the ring transfer functions, such as the mechanical impedance or frequency spectrum. External behavior of the metal ring is described in frequency domain by a system with four mechanical ports (one for each external surface).

Comparing the spectrum obtained using the described Matlab/Simulink model of metal rings and discs, with the experimental measurements of resonant frequencies for different rings and discs of duralumin and steel, obtained by using vibrating platform. It is evident that the Matlab/Simulink model gives a very good prediction of the metal ring behavior in all cases. Obtained resonant frequency which depending of the size of endings is compared with analogous results obtained using the apparent elasticity method, which has so far represented the best 1D model of metal endings. It is shown the frequency range which is commonly used in practical applications in the field of power ultrasound.

The Matlab/Simulink model gives a very good prediction of the metal ring behavior. It can be applied successfully to design and optimize ultrasonic sandwich transducers for industrial applications. In a future work our aim is to improve the performance of the model in order to obtain a reliable tool for more complex Langevine ultrasonic sandwich transducer design.

Acknowledgements

This work has been funded by the Serbian Ministry for Science under the projects TR33035, III43014 and OI172057.

7. References

1. E.A.Neppiras, "The pre-stressed piezoelectric sandwich transducer", Ultrasonic.
2. D.Mančić, G.Stančić, Journal of Sandwich Structures & Materials, 12 (2010) 63.
3. D.Mančić, M.Radmanović: Facta Universitatis, Series: Working and Living Environmental Protection, 2 (2004) 293.
4. I.Jovanović, D.Mančić, V.Paunović, M.Radmanović, Z.Petrušić: "A Matlab/Simulink Model of Piezoceramic Ring for Transducer Design", ICEST, Niš, 2011, Vol. III, pp. 952-955.
5. D.Mančić, M.Radmanović, Journal of Technical Acoustics, 2 (2002) 1.1.
6. M. R. Hatch, Vibration Simulation Using Matlab and Ansys, Chapman & Hall/CRC, Boca Raton, 2001.
7. D.Mančić, M.Radmanović, Facta Universitatis, Series: Mechanics, Automatic Control and Robotics, 4 (2004) 141.

Садржај: Метални наставци су саставни део различитих ултразвучних сендвич претварача. У овом раду приказан је нови тродимензионални Matlab/Simulink модел металних прстенова и дискова коначних димензија. Уз помоћ овог модела, који описује

и дебљинске и радијалне резонантне модове, као и међусобну спрегу ова два мода, може се веома лако израчунати механичка импеданса неког узорка. Приказане су криве зависности резонантне фреквенције у функцији дужине металних прстенова и дискова, од различитих материјала и за различите одабране димензије. Предложени Matlab/Simulink модел је једноставнији за имплементацију од осталих аналитичких модела. На овај начин је омогућено модификовање једподимензионе теорије и поједностављено моделовање и пројектовање ултразвучних сендвич претварача са кратким металним наставцима. Поређења резултата добијених овим, предложеним моделом, и експерименталних резултата приказана су на крају рада.

Кључне речи: Метални прстен/диск, Matlab/Simulink модел, резонантна карактеристика, фреквентни спектар.
