

DEFORMATION INFLUENCE ON A LIFETIME OF WELDING ELECTRODE TIPS

Ján Viňáš¹, Milan Ábel², Ľuboš Kaščák³

Received 4th February 2009; accepted in revised form 19th February 2009

Abstract

The contribution deals with the influence of welding electrode tips deformation on their lifetime. The influence of material properties, production technology and the intensity of welding electrodes load on their lifetime are presented. The electrode tips of the most used type of CuCr1Zr alloy of three basic standard shapes before and after the process of welding are evaluated. The process of welding is realized with low, middle and maximum welding parameters on programmable pneumatic spot welding machine VTS BPK 20. The influence of welding parameters on chosen material characteristics of welding tips is observed. Through the use of upsetting test, dependency of forming strength and deformation of material on used technology of welding tip production is observed.

Keywords: welding tips, lifetime, deformation

1. Introduction

One of the most dynamic developing world industries at the present time is automotive industry. Production of automobiles is continuously increasing and demands on quality are still higher. Various conventional and unconventional technologies of welding are used for joining of car-body sheets.

The most used method of car-body sheets welding is resistance spot welding. Despite of beginning to use special technologies of joining (laser welding, laser soldering, MIG welding and soldering, and also press joining and adhesive bonding), resistance spot welding still keeps the position of most widely used method of welding in automotive production.

Even though that it is conventional welding technology which is used practically for a long time, it is necessary to solve some problem tasks that successful resolution will lead to satisfaction of customers and automobile producers [1].

2. Methodology of experiments

Welding tips of shapes and dimensions presented at Fig. 1, 2, 3 were experimentally

evaluated [2]. Electrodes were made from CuCr1Zr alloy, which physical and chemical properties are according standard STN ISO 5182 presented in Table 1.

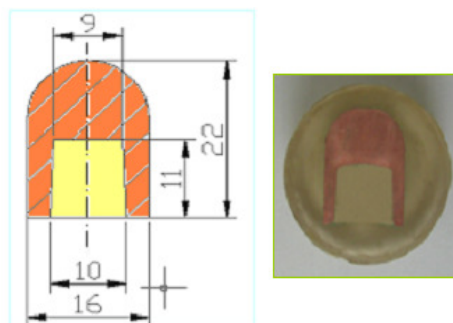

Fig. 1. Hemispherical electrode

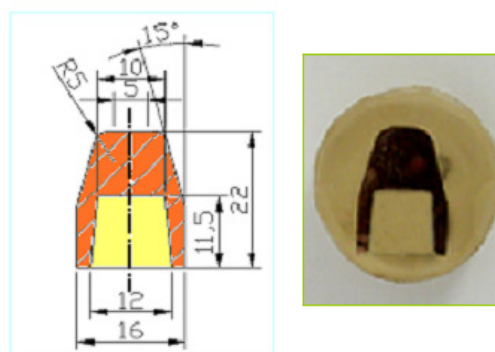

Fig. 2. Conical electrode

¹ J. Viňáš, Ing. PhD., ² M. Ábel, Ing. CSc., ³ Ľ. Kaščák, Ing. PhD. – Department of Technologies and Materials, Faculty of Mechanical Engineering, Technical University of Košice, Mäsiarska 74, 040 01 Košice, Slovak Republic.

*Corresponding author, e-mail address: jan.vinas@tuke.sk

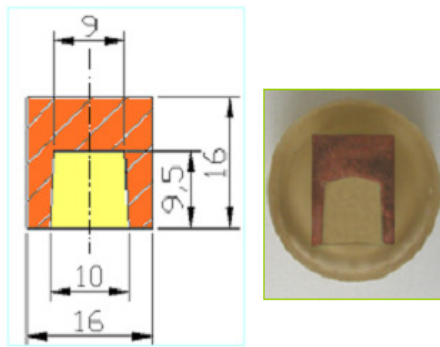

Fig. 3. Cylindrical electrode

Tab. 1
Physical and chemical properties of welding electrodes [3]

Alloy	Chemical composition [%]	Production	Conductance [s.m1.min]	Hardness [HV30]
CuCr 1Zr	Cu 98,12 – 99,47 Cr 0,5-1,4 Zr 0,02-0,2	drawn \geq 25 drawn < 25 forged	43 43 43	130 140 100

2.1. Description of welding material

Sheets of 2mm thickness of C 45 EN 10083-2-91 material were welded by resistance spot welding method. Chemical and mechanical properties of material stated by producer are shown in Table 2 and 3.

Tab. 2
Chemical composition of C 45 EN 10083-2-91 material in (%)

C	Mn	Si	Cr	Ni	Cu	P	S
0,42 ÷ 0,50	0,5 ÷ 0,8	0,17 ÷ 0,37	max 0,25	max 0,30	max 0,30	max 0,04	max 0,04

Tab. 3
Mechanical properties of C 45 EN 10083-2-91 material

Yield stress Re [MPa]	Tensile strength Rm [MPa]	Tensibility A10 [%]	Hardness HB	Yield stress Rp0,2 [MPa]
\geq 335	540 - 690	18	225	390 - 470

2.2. Welding parameters

Welding was realized by resistance spot welding machine BPK20 with using three different welding modes listed in Table 4.

Tab. 4
Welding parameters

Welding Modes	Welding Time (t_d) [time period]	Initial Current Value (I_3) [kA]	Welding Current (I_4) [kA]	Welding Force [kN]
1.	18	20	26	6,8
2.	18	15	22	6,8
3.	18	10	18	6,8

2.3. Measurement of microhardness

In accordance with ISO 6507-2 the microhardness of specimens was measured at device PMT 3 in two different dimensions (Table 6). Weighting of 200g was used.

2.4. Upsetting Test

Forming strength is stress whereat material is permanently deformed. Dependence between this stress and effective deformation was defined by the upsetting test. Loading parameters are in Table 5.

The samples of CuCr1Zr alloy due to standard STN ISO 5182 were used for experiments. Dimensions of the samples are shown in Fig. 4.

Tab. 5
Loading used in upsetting test

Measurement	1.	2.	3.	4.	5.	6.	7.
Force F [N]	20	40	60	85	99	119	140

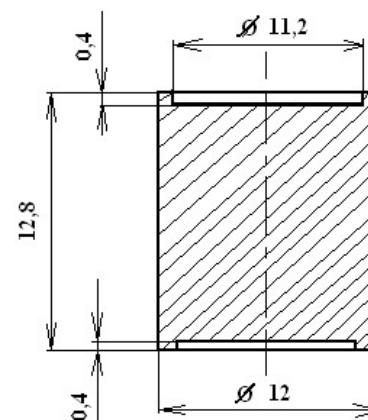

Fig. 4. Shape and dimensions of upsetting sample

3. Analysis of achieved results

Measured values in electrodes before welding in direction 1 show increasing trend of microhardness HV 0.2 from top part of electrode to its contact surface. The lowest values of microhardness within the range of 143-147 HV 0.2 were measured at cylindrical electrode. Higher values was observed at hemispherical electrode, they vary from 149 to 152 HV 0.2. The highest microhardness was found at conical electrode within the range from 150 to 153 HV 0.2.

Measured values in direction 2 are lowest in middle part and value of microhardness rises towards the edges. As well as in direction 1, the lowest values of microhardness (145-147 HV 0.2) were measured at cylindrical electrode. Values of microhardness at hemispherical electrode were within the range of 151-152 HV 0.2 and at conical electrode were within the range of 151-153 HV 0.2.

Low parameters of welding ($I = 18 \text{ kA}$) didn't affect on material microhardness. Microhardness in direction 1 has increasing trend towards the contact surface at all types of electrodes. Cylindrical electrode has the lowest values of microhardness from 145 to 147, values from 148 to 151 HV 0.2 were measured at hemispherical electrode and the highest microhardness from 149 – 152 HV 0.2 was again determined at conical electrode.

In direction 2 the lowest values were measured in the middle of electrode and in the marginal part of electrode. Microhardness of cylindrical electrode varies from 146 to 147 HV 0.2, hemispherical electrode from 149 to 151 HV 0.2 and conical electrode from 151 to 152 HV 0.2.

After welding process by using middle parameters ($I = 22 \text{ kA}$), values of microhardness listed below were measured. In direction 1 the microhardness increased towards the contact surface. So microhardness of cylindrical electrode was 135-142 HV 0.2, hemispherical electrode 144-147 HV 0.2 and conical electrode 145-148 HV 0.2.

In direction 2, the range of microhardness was at cylindrical electrode from 139 to 142 HV 0.2, at hemispherical electrode from 146 to 147 HV 0.2 and at conical electrode from 147 to 148 HV 0.2.

At all types of electrodes the microhardness decreased compared to the microhardness before and after welding process using low parameters.

Microhardness of electrodes after welding process using maximum parameters ($I = 26 \text{ kA}$) was the lowest in both of direction.

Tab. 6
Average values of microhardness HV 0.2 on tested specimens

		Cylindrical Tip		Hemispherical Tip		Conical Tip	
		Direction 1	Direction 2	Direction 1	Direction 2	Direction 1	Direction 2
Evaluation of microhardness before welding							
1	143	146	149	151	150	152	
2	144	145	151	151	151	151	
3	147	147	152	152	153	153	
Evaluation of microhardness after welding with low parameters							
1	145	147	148	151	149	151	
2	145	146	150	149	151	151	
3	147	147	151	151	152	152	
Evaluation of microhardness after welding with the middle parameters							
1	135	140	144	147	145	148	
2	138	139	145	146	146	147	
3	142	142	147	147	148	148	
Evaluation of microhardness after welding with the maximum parameters							
1	133	136	136	141	138	144	
2	135	135	138	139	142	144	
3	138	138	142	142	144	144	

In direction 1 the lowest values of microhardness were measured also at cylindrical electrode, and that is 133-138 HV 0.2. The range of microhardness at hemispherical electrode was 136-142 HV 0.2 and at conical electrode the microhardness was 138-144 HV 0.2.

In direction 2 the microhardness in the edge part of electrode was higher then in the middle of electrode. It was the same for all types of electrodes. Their microhardness varied from 135 to 138 HV 0.2 at cylindrical electrode, from 139 to 142 HV 0.2 at hemispherical electrode and at conical electrode the microhardness was 144 HV 0.2.

3.1. Dependence of strain strength and real deformation

Measured and calculated values after upsetting are in Table 7. Measured results of upsetting tests are presented at Fig. 5 and Fig. 6.

Tab. 7
Chemical composition (in wt. %) and tensile strength R_m Mg-alloys

	F [kN]	h_i [mm]	Δh [mm]	d_i [mm]
1.	20	11,4	1,4	12,7
2.	40	10,1	2,7	13,5
3.	60	8,3	4,5	14,9
4.	85	6,2	6,6	17,2
5.	99	5,6	7,2	18,1
6.	119	4,8	8	19,6
7.	140	4,1	8,7	21,2
	S_i [mm ²]	k_p [MPa]	φ	A [J]
1.	126,9	157,5	0,05	11,5
2.	143,3	279,1	0,103	41,6
3.	174,4	344	0,188	93,8
4.	233,5	385,5	0,315	175,9
5.	258,5	382,9	0,359	199,4
6.	301,6	394,6	0,426	243,7
7.	353,1	396,5	0,494	284,3

Upsetting test confirms theoretical assumes of material behavior during evaluation of mechanical characteristics by microhardness measurement.

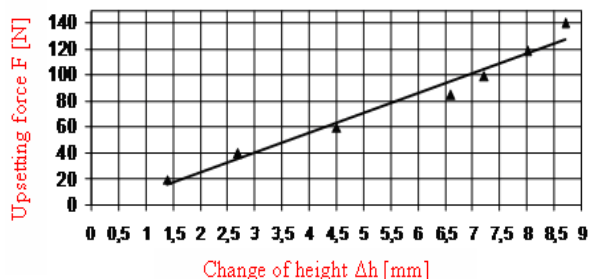

Fig. 5. Dependence of load F and change of cylinder height Δh

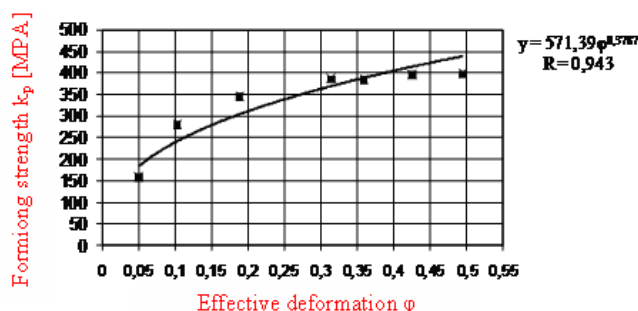

Fig. 6. Dependence of forming strength k_p and effective deformation φ

4. Conclusions

Based on the realized experimentation it is possible to observe that microhardness of all basic shapes of electrodes in all examined conditions mildly increased from top electrode towards its contact surface. In the middle part of electrode lower values of microhardness were measured in comparison with the edge parts, which was probably effected by water cooling process during the welding.

Low parameters of welding ($I = 18$ kA) don't have significant effect to the microhardness of tested material. Measured values of microhardness before welding and after welding varied minimally. Progressive increasing of welding current ($I = 22 - 28$ kA) caused the microhardness decreasing at all examined shape of electrodes. Lowest values of microhardness HV 0,2 were measured by using these electrodes in welding with maximum parameters.

Cylindrical electrode has the lowest values of microhardness during the whole experimentation. Following the hemispherical electrode the highest values of microhardness were measured at conical electrodes. It could be said that lifetime of welding tips is effected by shape of electrodes and mainly the technology of electrodes production. It is possible to expect that the conical one has the longest lifetime from all tested shapes, that is being verified in practice now.

Big influence on tips lifetime has also used technology of their production. It is possible to achieve strengthening of the material by forming – increase of hardness of the surface layers, which enables electrodes to be used for hardest modes of resistance spot welding. Strengthening of the surface layers is an alternative to increasing amount of alloying elements in material in order to achieve higher hardness with decreasing conductivity.

For each technology of electrodes production it would be also suitable to declare the rate of thermal processing and transfer of heat through the tool and joined material in the weld point and take consideration of heat and pressure influence on the change of welding electrodes lifetime.

Nowadays, methods of prolonging the lifetime of welding tips are continuously being researched, especially at dynamic developing automobile industry, where critical factors affected at welding tips lifetime are surface coatings of steel sheets, which create eutectics in the electrodes contact surface and cause electrical conductivity reduction.

Acknowledgements

Contribution was elaborated within solving the grant project VEGA №. 1/0206/08.

References

- [1] Lipa, M.: Odporové zváranie. 1. vyd.. Bratislava: Weldtech, 1995. 265 s.
- [2] Ábel, M., - Viňáš, J.: Hodnotenie vplyvu zväracích parametrov na životnosť zväracích špičiek. In: Acta Mechanica Slovaca. roč. 10, č. 4-a Povrchové inžinierstvo, Košice: Viena, 2006, s. 7-12.
- [3] STN ISO 5182: Zváranie. Materiály na odporové zväracie elektródy a pomocné zariadenia
- [4] Ábel, M. - Evin, E.: Analýza vplyvu stupňa deformácie na životnosť zväracích elektród pre odporové zváranie. In: Strojné inžinierstvo 2006 : Zborník príspevkov, Bratislava : STU, 2006. s. 514-520.
- [5] Kaščák, Ľ - Spišák, E.: Resistance spot welding of three steel sheets for automotive industry. In: PRO-TECH-MA '07 : Progressive Technologies and Materials : International scientific conference, Rzeszów - Bezmiechowa, Poland, Rzeszów : Politechnika Rzeszowska, 2007. p. 49-54.
- [6] Janota, M.: Procesy a riadenie odporového zvárania. Bratislava: Výskumný ústav zväračský 1985. 120 s.
- [7] Aslanlar, S.: The effect of nucleus size on mechanical properties in electrical resistance spot welding of sheets used in automotive industry, In: Elsevier – Materials & Design, 2004, s.125-131.
- [8] Turňová, Z. - Kasala, M.: The evaluation of erosive wear of hard facing metals. In: Materials Engineering. Materiálové inžinierstvo. - ISSN 1335-0803. - Roč. 14, č. 1 (2007), s. 42-45.
- [9] Neumann, H. - Moravec, J.: Aplikace simulačního programu SYSWELD pro určení parametrů svařovacího procesu. . Mezinárodní konference PRO-TECH-MA 2006. Časopis Acta Mechanica Slovaca, s. 253-258.