

A novel hovering type of fixed wing aircraft with stealth capability

Anniversary Session “Celebrating 100 year of the first jet aircraft invented by Henri Coanda”, organized by INCAS, COMOTI and Henri Coanda Association, 14 December 2010, Bucharest, Romania

Valeriu DRĂGAN*

*Corresponding author

“POLITEHNICA” University Bucharest, Faculty of Aerospace Engineering
Str. Gheorghe Polizu, nr. 1, sector 1, 011061, Bucharest, Romania
drvaleriu@gmail.com

DOI: 10.13111/2066-8201.2010.2.4.13

Abstract: *The tactical need for fixed wing aircraft with hovering capably has long been recognized by the military for two reasons: increased safety when landing on aircraft carriers and higher velocities that the ones obtainable with rotary wing aircraft.*

Thus far, the only concept governing the field of vertical flight was to use thrust either from a lift fan-F35, puffer ducts –Harrier or smaller jet engines-D0 31 or Yak-141, i.e. direct lift thrust.

In this paper we will look at the prospect of using a combination of the Coanda effect with the Venturi effect to generate lift by so- called “supercirculation”. This novel approach can yield many advantages to conventional vertical lifting by providing a more stable platform and requiring lower power settings – and thus lower fuel consumption.

The aircraft has a fixed, negatively sweped wing that uses circulation control to achieve lift at zero air speed. The fluid used for supercirculation will come from the fan thrust reversers – which, if correctly managed, can give a sufficient flow for lifting the craft and also a negative thrust component to compensate for the positive thrust of the primary flow (not diverted).

Key Words: Coanda effect, super circulation, stealth, UAV, VTOL.

1. INTRODUCTION

The present paper investigates the possibility of using the Coanda effect to achieve vertical flight capabilities while maintaining the general architecture of a conventional stealthy fixed wing aircraft.

As it will become apparent, obtaining lift from the phenomenon known as super circulation is directly dependent on the Coanda effect. Also, the paper includes a case study of such an aircraft with a super circulated wing that maintains the low observability of conventional stealth aircraft.

Supercirculation has been used previously on such aircraft as the Antonov An-74 and the Boeing YC-14, in both cases, the supercirculation was produced by diverting the secondary fan flow over a small chord-wise direction.

As a result, both aircraft were able to take off on shorter runs than otherwise possible, however they lack the capacity to hover-which is the main focus of the case study presented here. In our case, in order to maximize the lift provided by the Coanda effect, the fan flow is diverted span-wise –thus covering a much larger area (in fact the entire upper surface of the wing). Because the supercirculation is not as an energy demanding process as the direct lift or fan lift used on other hovering aircraft, the UAV may hover for extended periods of time providing a new tactical capability for the user.

2. THE CONCEPT AND GENERAL LAYOUT OF THE AIRCRAFT

The case study relies on a negative sweep curved wing aircraft that pivots around an axis parallel to the roll axis of the aircraft; the fuselage has a largely triangular cross section with side serpentine inlets that employ boundary layer suction in order to reduce the operability of the aircraft.

The propulsion system uses a single turbofan with high by-pass ratio with a modified thrust reverser that uses a ramp system to feed compressed air from the fan over the upper surface of the wing.

Supercirculation is controlled by pivoting guide vanes that direct the air from the thrust reverser over the wing.



Fig.1 Axonometric view of the stealth hovering UAV concept

Hovering is achieved when two factors coincide: the lift compensates the gravitational force and the thrust compensates the drag. In our case, we aim to have zero overall thrust while operating the engine at a high throttle setting.

In order to do this, we can reverse the secondary i.e. fan flow at a certain angle so that the resulting force compensates fully the thrust provided by the first flow. For using the fan flow we will thus need to use a negative sweep wing – it should be noted that the angle of sweep is not entirely dictated by the fan flow reversed direction, as this can be varied through the pivoting guide vanes.

The construction of the thrust reverser is generically depicted in Fig.3; it comprises a two ramp system –for a better aerodynamic efficiency- actuated by a central hydraulic mechanism.

The nozzle has a flat loft transition duct that leads to the pivoting guide vanes assembly. The guide vane assembly is actuated via a unison rod that connects all the individual blades. On the exterior of the fuselage, the doors of the thrust reverser have serrated edges in order to minimize reflections to the enemy radar.

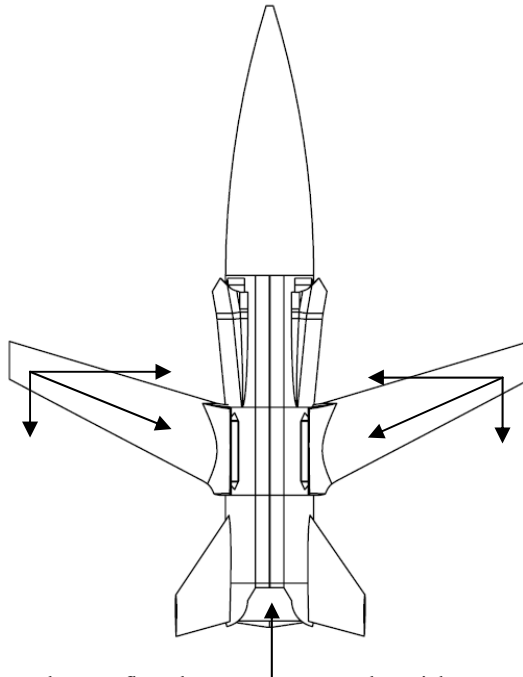

Fig.2 Top view thrust forces, the core flow thrust compensates the axial components of the two reversed fan flows

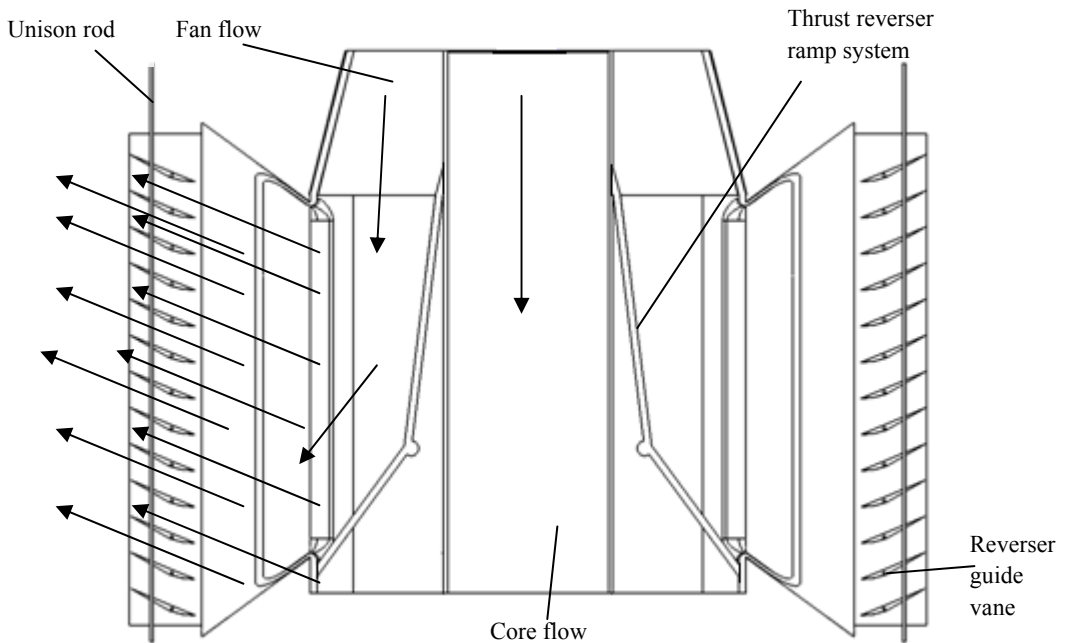

Fig.3. Top view of the schematics of the thrust reversal unit in hovering mode

Another aspect required for the super circulated wing is the span wise curvature without which the Coanda effect is not present and lift cannot be obtained. A paradox arises since the optimal wing for the Coanda effect is far too curved for an efficient conventional aerodynamic flight. Both capabilities are important and thus there is the need for a geometry

variation: a pivoting wing that will droop down in order to be optimal in supercirculation mode and that will go up in normal aerodynamic flight.

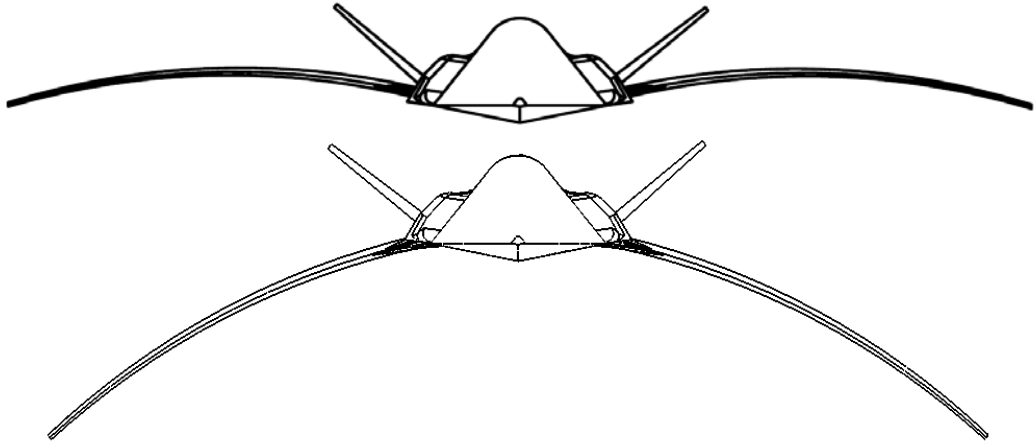

Fig.4 front view with the two wing positions: conventional flight mode (top) hovering mode (down)

Trimming is a critical aspect of the hovering mode since there are no surfaces, aside the wings themselves, that can be used to trim the aircraft and make it stable. The solution chosen in this case is to vary the pressure center axial position by varying the angle of the variable guide vanes. Used in conjunction with fuel trimming, the supercirculation trimming might prove sufficient for a small UAV. On larger, manned, aircraft safety is paramount and additional trimming mechanisms while in hovering mode must be used. Conventional flight trimming is made using the V-tail.

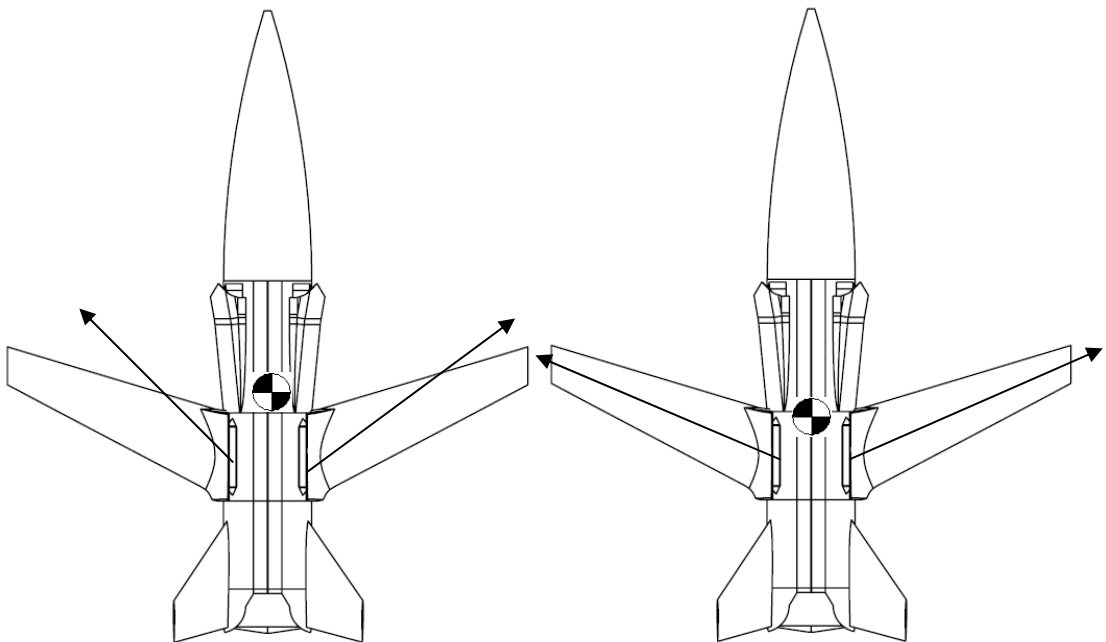

Fig.5 Hovering trimming by varying the supercirculation guide vane assembly angle depending on the position of the center of gravity

3. CFD STUDIES OF THE SUPERCIRCULATION HOVERING MODE

A series of CFD studies has been carried out in order to prove whether or not the fan flow is sufficient to provide supercirculation lift in ideal conditions. Table 1 provides the critical aspects such as the boundary conditions used and the dimensions of outlet ports and surface areas of the wing as well as the relevant results obtained from the simulation.

Table 1-Input and output parameters of the CFD study

parameter	value
Atmospheric pressure[Pa]	101661
Fan flow pressure[Pa]	100524
Fan flow velocity[m/s]	105.948
Flow temperature[K]	293
Fan mass flow[kg/s]	0.0766974
Lift [N]	15.0126
Wetted area of the fan flow[m ²]	0.0114332

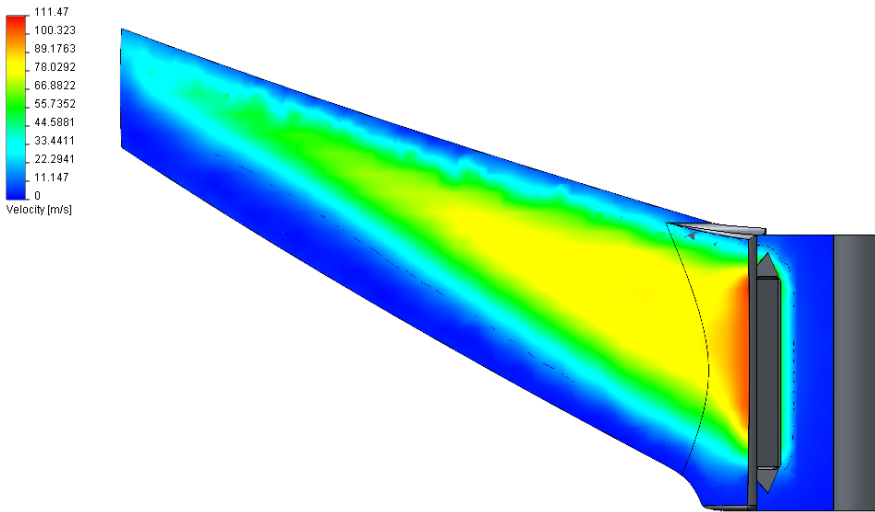

Fig.6 Velocity plot over the upper surface of the wing with a low velocity setting

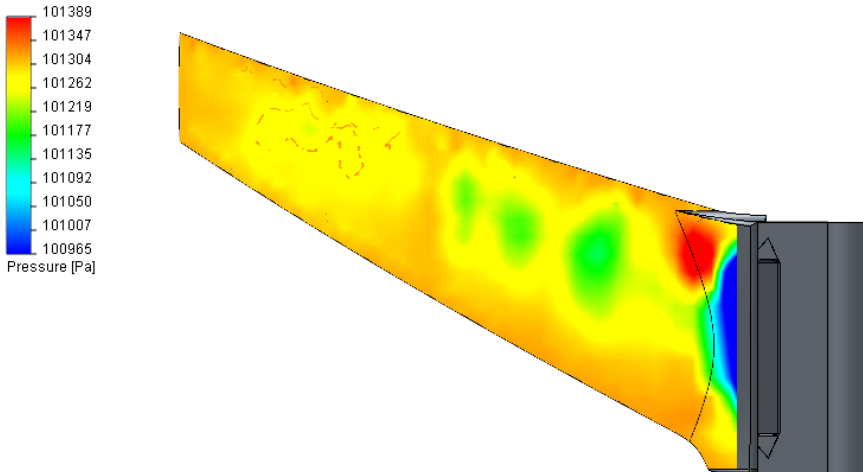

Fig.7 Pressure plot of the super-circulated upper surface of the wing

4. REMARKS AND CONCLUSIONS

A subsonic stealthy UAV with hovering capabilities case study has been tested and presented. The hovering capability is provided by the Coanda effect using super circulating flow from the fan of the turbine engine on board the aircraft. Preliminary CFD studies provide proof of concept and validate the initial hovering principle. Also a thrust reverser has been developed in order to provide a more aerodynamic flow towards the outlet of the fan, over the super circulated wings.

Computational Fluid Dynamics have showed that the reversed fan flow can provide more than sufficient lifting force through supercirculation in ideal conditions. Further study is needed in order to observe in closer detail the phenomena that appear on large, real wings with this kind of circulation control.

Also more detailed studies have to be performed to improve hovering trimming, a possible solution might be a smaller Coanda effect lifting surface at the exhaust nozzle.

5. REFERENCES

- [1] Arthur E. Phelps, William Letko and Robert L. Henderson, Low-Speed Wind- Tunnel Investigation of a Semispan STOL Jet Transport Wing-Body With an Upper- Surface Blown Jet Flap. NASA TN D-7183, 1973.
- [2] Kiyoshi Aoyagi, Michael D. Falarski and David G. Koenig, Wind Tunnel Investigation of a Large-Scale Upper Surface Blown-Flap Transport Model Having Two Engines. NASA TM X-62,296, 1973.
- [3] Arthur E. Phelps, III and Charles C. Smith, Jr., Wind-Tunnel Investigation of an Upper Surface Blown Jet-Flap Powered-Lift Configuration. NASA TN D-7399, 1973.
- [4] Charles C. Smith Jr., Arthur E. Phelps, III and W. Latham Copeland, Wind- Tunnel Investigation of a Large-Scale Semispan Model With an Unswept Wing and an Upper-Surface Blown Jet Flap. NASA TN D-7526, 1974.
- [5] James P. Shivers and Charles C. Smith Jr., Preliminary Static Tests of a Simulated Upper-Surface Blown Jet-Flap Configuration Utilizing a Full-Size Turbofan Engine. NASA TM X-71931, 1974.
- [6] Charles C. Smith Jr. and Lucy C. White, Pressure Distribution of a Twin-Engine Upper-Surface Blown Jet-Flap Model. NASA TM X-71937, 1974.
- [7] Lysle P. Parlett, Free-Flight Wind-Tunnel Investigation of a Four-Engine Sweptwing Upper-Surface Blown Transport Configuration. NASA TM X-71932, 1974.
- [8] Joseph L. Johnson Jr. and Arthur E. Phelps, III, Low-Speed Aerodynamics of the Upper-Surface Blown Jet Flap. Ereprint] 740470, SOC. Automot. Eng., Apr.-May 1974.
- [9] John K. Wimpres, Upper Surface Blowing Technology as Applied to the YC- 14 Airplane. preprint 730916, SOC. Automot. Eng., Oct. 1973.
- [10] Howard Skavdahl, Timothy Wang and William J. Hirt, Nozzle Development for the Upper Surface - Blown Jet Flap on the YC-14 Airplane. Automot. Eng., Apr.-May 1974.[reprint] 740469, SOC.
- [11] M. L. Lopez and C. C. Shen, Recent Developments in Jet Flap Theory and Its Application to STOL Aerodynamic Analysis. AIAA Paper No. 71-578, 1971.
- [12] Thomas R. Turner, Edwin E. Davenport and John M. Riebe, Low-Speed Investigation of Blowing From Nacelles Mounted Inboard and on the Upper Surface of an Aspect-Ratio-7.0 35' Swept Wing With Fuselage and Various Tail Arrangements. NASA MEMO 5-1-59L, 1959.
- [13] Dietrich Kuechemann and Johanna Weber, Aerodynamics of Propulsion. McGraw-Hill Book Co., Inc., 1953.
- [14] H. S. Ribner and N. D. Ellis, Aerodynamics of Wing-Slipstream Interaction. C.A.S.I. Trans., vol. 5, no. 2, Sept. 1972,
- [15] C. Edward Lan, An Analytical Investigation of Wing-Jet Interaction. CRINC-FRL 74-001 (NASA Grant NGR 17-002-107), Univ. of Kansas, Apr. 1974. (Available as NASA CR- 138140.)
- [16] E. S. Levinsky, H. U. Thommen, P. M. Yager and C. H. Holland, Lifting-Surface Theory for V/STOL Aircraft in Transition and Cruise. I. J. Aircraft, vol. 6, no. 6, Nov.-Dec. 1969, pp. 488-495.
- [17] C. Edward Lan, A Quasi-Vortex-Lattice Method in Thin Wing Theory. J. Aircraft, vol. 11, no. 9, Sept. 1974, pp. 518-527.
- [18] Everett W. Purcell, The Vector Method of Solving Simultaneous Linear Equations. J. Math. & Phys., vol. 32, no. 2-3, July Oct. 1953, pp. 180-183.

- [19] D. A. Spence, The Lift Coefficient of a Thin, Jet-Flapped Wing. Proc. Roy. SOC. (London), ser. A, vol. **238**, no. 1212, Dec. 4, 1956, pp. 46-68.
- [20] M. Seidel, The Influence of an Inclined Jet on the Flow Field in the Vicinity of a Lifting Surface and on Its Aerodynamic Coefficients. NASA TT F-14,956, 1973.
- [21] Thomas G. Gainer, Low-Speed Wind-Tunnel Investigation To Determine the Aerodynamic Characteristics of a Rectangular Wing Equipped With a Full-Span and an Inboard Half-Span Jet-Augmented Flap Deflected 55°. NASA MEMO 1-27- 59L, 1959.
- [22] J. Williams, S. F. J. Butler and M. N. Wood, The Aerodynamics of Jet Flaps. R. & M. No. 3304, British A.R.C., 1963.
- [23] C. Edward Lan, Some Characteristics of Airfoil-Jet Interaction With Mach Number Nonuniformity. J. Aircraft, vol. **11**, no. 8, Aug. 1974, pp. 491-494.
- [24] C. Edward Lun and James F. Campbell, THEORETICAL AERODYNAMICS OF UPPER-SURFACE-BLOWING JET-WING INTERACTION C. Lungley Research Center Hampton, Va. 23665