

WATER ENERGY IN HYDROAMELIORATIVE SYSTEMS USING THE HYDRAULIC TRANSFORMER TYPE A. BARGLAZAN AND THE HYDRAULIC HAMMER (HYDRAULIC PUMP)

Teodor Eugen Man, Laura Constantinescu, Dima Attila Blenesi
Politehnica" University of Timisoara, Faculty of Hydrotechnical Engineering,
George Enescu Street, no 1A, cod 300022, Romania
E-mail: eugentman@gmail.com

Abstract

This paper presents two examples of exploitation of water energy that can be used in the irrigation field. First of these examples is the hydraulic transformer type A. Barglazan used for irrigation, pumped water is taken directly from the river's well, using a hydraulic pump which simultaneously carried out a double transformation in this way: hydraulic energy into mechanic energy and mechanical energy into hydraulic energy. Technology preparation and devices design was done in record time, seeing that this constructive solution is more robust, reliable and with improved energy performance versus the laboratory prototype. The experimental research which was made at 1:1 scale proved their good function over time. Another example is the hydraulic hammer (hydraulic pump) that uses low-head energy to pump water, with a global efficiency of about 10 - 50%. Currently, the new situation of private ownership of land provides conditions for new pumping microstations to be made where irrigation is necessary and optimal hydraulic locations exist.

Keywords: hydraulic transformer, hydraulic hammer (pump), water energy, pumping microstation, local irrigation arrangement

1. INTRODUCTION AND GENERAL PROBLEMS

The main purpose of this paper is to emphasize the possibilities for efficient utilization of low-head energy (water energy), available in Romania and in many other countries of the world.

1.1 The Hydraulic Transformer A. Bârglăzan

The research for hydraulic transformer pump realization was started since 1936 by prof. Aurel Barglazan who in 1940 defended his PhD thesis. [2]

For the case in which is used for irrigation, pumped water is taken directly from the river's well, using a hydraulic pump which simultaneously carried out a double transformation in this way: hydraulic energy into mechanic energy and mechanical energy into hydraulic energy. This situation can be found in Romania and obviously in any other country where we have water courses where local irrigation can be done on relatively small

surfaces (for vegetables, grape and fruit tree orchards) afferent to those water courses, where the water level is below ground level and where we can create small hydraulic heads of 1 – 4 m with high available flows.

By utilization these pumps we can lift water from river and distribute it on the agricultural field.

The constructive type realized by A. Barglazan in 1940 was redesigned in 1989 by a group of specialists and 10 prototypes were produced which were tested and placed in different irrigation arrangements. [1,3]

1.2 Hydraulic Hammer (Hydraulic Pump)

It was invented in 1973 by the Montgolfier brothers in Southern France, [4] Ardiche region, being used for irrigations at vegetable plantations, vineyards, having as basic principle in function the hammer stroke, which is obtained through the sudden closing of water running from a pressurized pipe, with the help of a flap. The overpressure water from pipe is directed into a vessel which has at the top an air pillow which will compress. According to

the relaxation of compress air volume, another flap will be closed and the air will push the water from the vessel through an overflow pipe into a reservoir at the specific irrigation height. The hydraulic pump works with pressure shocks in a discontinuous mode with close-open movements of 2 flaps working against each other tied in with the going-return time of the overpressure wave in the carrier pipe, which is going with a speed called wave speed. In Caras-Severin county there were realized and installed by IEELIF Resita over 60 pumping microstations for local vegetable irrigation. Both machines work with low-head energy (river, channel waterfalls 1m high) achieving the water pumping for local irrigations.

2. DESCRIPTION AND FUNCTIONAL CHARACTERISTICS OF HYDRAULIC TRANSFORMER AND HYDRAULIC POMP

2.1 Hydraulic Transformer

The hydraulic transformer is a machine made up by associating some main parts of a special hydraulic turbine (Kaplan) and of some core elements of a centrifugal -or radial-axial pump. It is noticed that the Kaplan turbine propellers are fixed and on this is set the pump rotor, resulting in a joined-together and rigid mix of rotor and turbine-pump.

As it results from the function principle, the Aurel Barglazan transformer is an open circuit transformer as opposed to the Fottinger hydrodynamic transformer which is a closed circuit. An energy transformation from hydraulic E_h into mechanical energy E_{stm} and again into hydraulic E_h energy took place in the case of the latter.

$$E_h \rightarrow E_{stm} \rightarrow E'_h$$

In the case of the Fottinger transformer, the energy transformation took place for mechanical energy energy into hydraulic energy and again into mechanical energy energy.

$$E_{stm} \rightarrow E_h \rightarrow E'_{stm}$$

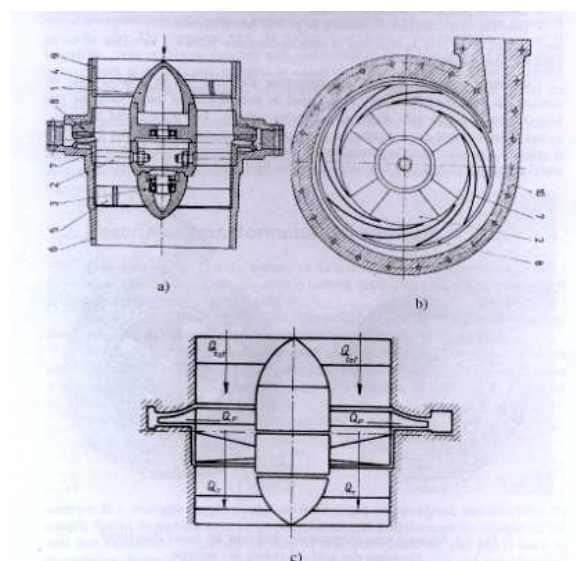

Figure 1 Hydraulic transformer type Aurel Barglazan: a) longitudinal section; b) transversal section; c) Kaplan-centrifugal pump assembly (1-2- pallets; 3,4,5- aspiration tub; 7- rotor; 8- spiral chamber; 9- feed pipe; 10,11- pressure pipe)

The main parameters which characterise the functioning of the Barglazan transformer are:

K – water flow which enters into the transformer; K_T – turbined water flow; K_p – pumped water flow; H_T – available total water fall at the entrance in transformer; H_p – pump height; n_T – turbine rotor rotation speed; n_p – pump rotor rotation speed; η_T – turbine efficiency; η_p – pump efficiency.

The fundamental relationships between these parameters are:

- continuity equation

$$Q = Q_T + Q_p$$

- energetic equation, turbine and pump power

$$P_T = \gamma \cdot Q_T \cdot H_T \cdot \eta_T \quad (1) \text{ (turbine power)}$$

$$P_p = \frac{\gamma \cdot Q_p \cdot H_p}{\eta_p} \quad (2) \text{ (pump power)}$$

but: $\eta_T = \eta_p$ and $P_T = P_p$ we have:

$$Q_p \cdot H_p = Q_T \cdot H_T \cdot \eta_T \cdot \eta_p \quad (3)$$

where $\eta = \eta_T \cdot \eta_p$; is the global efficiency of the transformer.

The characteristic curves of hydraulic transformer are presented in figure 2a and 2b for the two constructive types.

To optimise the functioning of the hydraulic transformer, prof. Mircea Barglazan (author, son) elaborated a graphical-analytical procedure for the “m” transformer optimization in an open circuit.

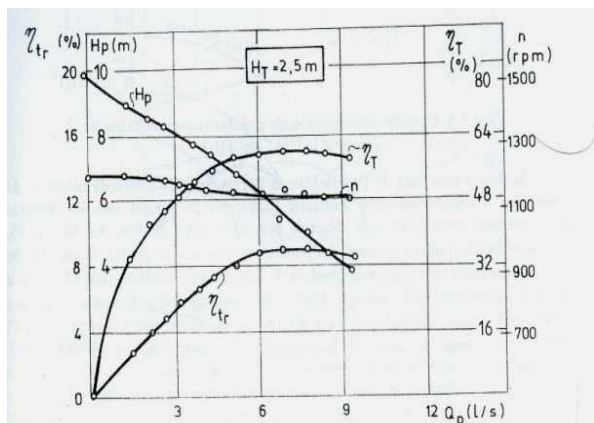

a)

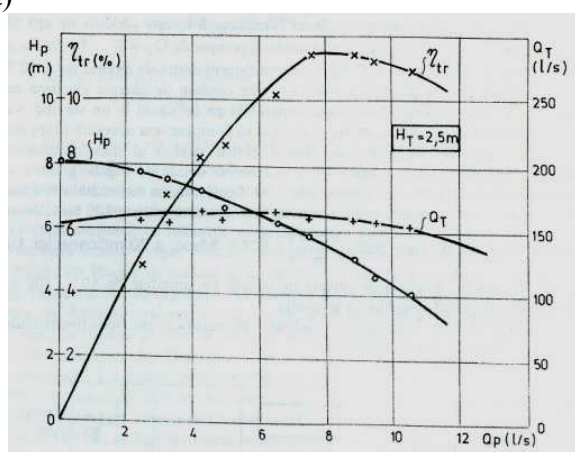

b)

Figure 2 Characteristic curves of the hydraulic transformer: a) Type A Barglazan; b) Type TH-1-executed at UMT.

2.2 Hydraulic Pump

In figure 3 is presented a longitudinal section through the hydraulic pump with the component parts visible.

The functioning principle of hydraulic pump (hydraulic hammer type IEELIF Resita) consists of the fact that a water source which ensures a flow Q (l/s) with a hydraulic head H_s = 0,8 – 1,6m holds open flaps C_1 , where flow Q_e is evacuated. Letting flap C_1 close suddenly, or if it is closed, hitting it with a crowbar powerfully enough to open it causes the hammer stroke (of overpressure) to be

transmitted upstream, which opens flap C_2 , and allows a water surplus to deform the rubber membrane and compressing the air from the air chamber.

There follows the relaxation phase of the air, which compresses the water in the water return chamber, closing flap C_2 . Simultaneously the pumping at high H_p is achieved. The organ which maintains the pumping is flap C_1 , its route adjusted with a rod articulated at the flap and which has a stopper in order to not open totally flap C_1 and which maintains the hammer stroke going back-and-forth between flap C_1 and the intake reservoir. This overpressure wave is going through the length of the action pipe 20 m long and 300 mm diameter, with a speed named wave speed.

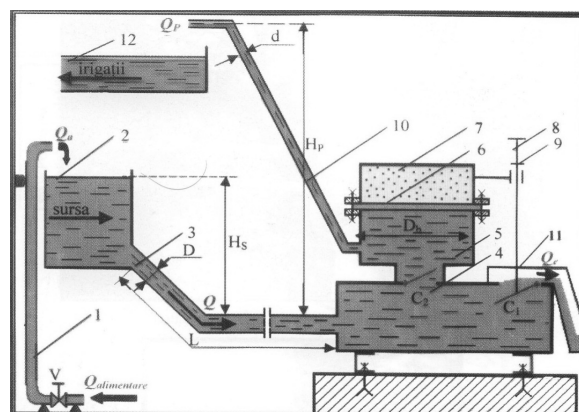

Figure 3 Sketch of the hydraulic pump in open circuit at the Politehnica University of Timisoara’s Drainage and irrigation laboratory (1-water feed; 2-intake pool; 3-water feed Q pipe; 4-water intake chamber; 5-water return chamber; 6-rubber membrane; 7-air chamber; 8-rod; 9-movement limitation; 10-return pipe; 11-outlet groove Q_e ; 12-build-up pool; C_1 -water outlet and hammer stroke flap; C_2 -pumping flap)

Going-returning trip of overpressure wave, which closes flap C_1 and opens flap C_2 is realized in (time):

$$\tau = \frac{2 \cdot L}{C} \quad (4)$$

where wave speed is:

$$C = \frac{\sqrt{\frac{E_a}{\rho}}}{\sqrt{1 + \frac{D \cdot E_a}{\delta \cdot E}}} \quad (5)$$

For an intake pipe with a diameter of 300 mm, the steel wall pipe thickness of $\delta=5\text{mm}$, $E_a=2 \cdot 10^8 \text{kgf / m}^2$ and $\frac{E_a}{E} = 0,01$ there results the wave speed (overpressure wave speed) $C=1100 \text{ m/s}$ and for $L=20\text{m}$ results $\tau=0,04 \text{ sec}$. Consequently, the stopper for the adjustment of the closing flap C_1 frequency it is very important to realize the function of the τ cycle length.

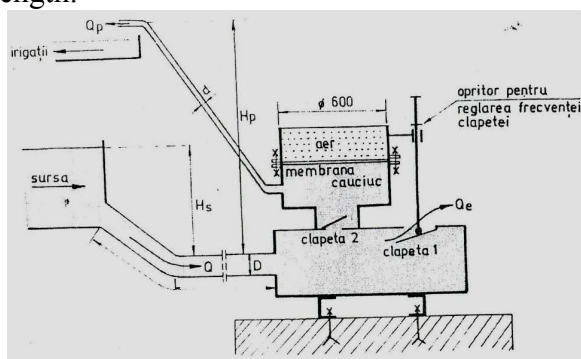

Figure 4 Hydraulic hammer type IEELIF Resita, longitudinal section

If an overpressure is not obtained of the overpressure wave upon its return, with flap C_1 closing, it can happened that the hydraulic hammer will stop functioning intermittently. It is necessary to realize the resonance in flap C_1 function at closing, with the opening of flap C_2 and the returning of the overpressure wave, hammer stroke to obtain an infinite cyclical movement. The advantage of this hydraulic pump type IEELIF Resita over the old hydraulic pump consists of the rubber membrane which isolates the air, maintaining an air elastic pillow which is not dissolved in the water.

For calculations we use the equations:

-continuity:

$$Q=Q_e+Q_p \quad (6)$$

-energy:

$$Q \cdot H_s \cdot \eta = Q_p \cdot H_p \quad (7)$$

With the recommendation:

$$H_p=(3 \dots 7)H_s$$

Where:

Q - intake water flow which comes from the hydraulic hammer ; Q_E - water flow evacuated in downstream Q_P - pumped water flow; H_S - available water flow (0,8...1,6m); H_P -

water flow high; η - global efficiency of the hydraulic pump.

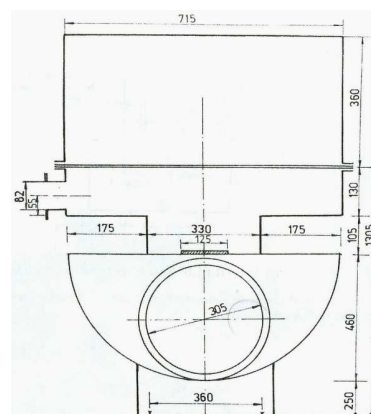

Figure 5 Hydraulic hammer type IEELIF Resita, cross section

3. RESULTS OF EXPERIMENTAL RESEARCH IN LABORATOR AND FIELD

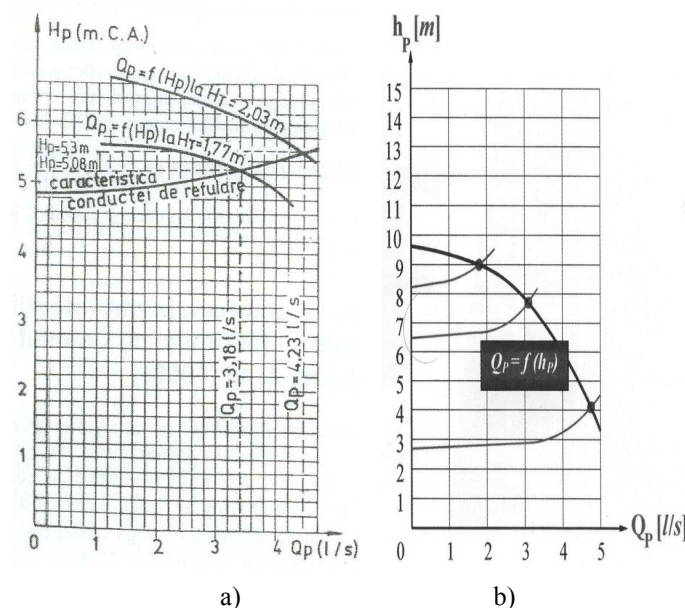

Figure 6 The characteristic shapes of the TH-1 hydraulic transformer placed at: a) Sanmartinul Sarbesc, Timis county; b) Ineu (Mocnea), Arad county, Romania

3.1. The Hydraulic Transformer

On the hydraulic transformer at the Drainage and irrigation Laboratory at Faculty of Hydrotechnics with Acad. Ioan Anton at Faculty of Mechanics, at Hydraulic Machinery and production specialists was made experimental research on the two Romanian

irrigation micro-pumping stations: a) Timisat at Sanmartinul Sarbesc, Timis county on Teba canal; b) on Morilor canal at Ineu Arad county. The characteristic shapes the TH-1 transformer obtained at the two irrigation micro-pumping station are presented in figure 6 a) and b).

3.2. The Hydraulic Hammer

The experimental research carried out on the hydraulic hammer has taken place in follows irrigation micro-pumping stations: a) at Nicolint, Caras- Severin county; b) at the Land Reclamation Laboratory at Faculty of Hydrotechnics of Timisoara.

For the Nicolint microstation the level difference used for water mill was used for hydraulic pumping to raise up water into a tower for local irrigation. The Nicolint microstation is equipped with three hydraulic pumps with the recipients 600 mm in diameter. The measurements [3] made in field are:

$$H_S = 1,64 \text{ m}; \quad H_P = 5,44 \text{ m}; \\ Q_P = 2,5 \text{ l/s/pump}$$

Considering global efficiency $\eta = 50 \%$ for the three hydraulic pump there results the following flow into the source:

$$Q = 3 \cdot \frac{H_P}{H_S} \cdot \frac{Q_P}{\eta} = 3 \cdot \frac{5,44}{1,64} \cdot \frac{2,5}{0,5} = 50 \text{ l/s} \quad (8)$$

and 16,58 l/s per pump which is given back to the brook and only 7,5 l/s is pumped for the irrigation of the 10 ha vegetables culture in the area. So the specific flow of water is 0,8 l/s/ha. At the Land Reclamation Laboratory Timisoara were studied flap gate C_1 turning problems depending on the water conveyance structures length, the available fall and having measure the flow pump and the height pump. The global results are about 50% efficiency.

4. CASE STUDIES

4.1 The Hydraulic Transformer

4.1.1 Pumping Microstation For Irrigation On Teba-Timisat Channel, Sanmartinul Sarbesc, Timis County

The draining system Teba-Timisat (fig.7), trough its 60Km long collector chanell, is used in rainy periods for draining, flowing into the Timis river at Cruceni. In drought periods in the Bega channel there is an available flow of $6\text{m}^3/\text{s}$ and at Sanmihai this collector channel is being feed at a rate of 450 l/s, this having along more hydrotechnical nodes. The hydrotechnical node no.2 near Sanmartinul Sarbesc was chosen for the hydraulic transformer in fig.6 to be placed. It was calculated that the irrigable area potential is of 1,500 ha using this irrigation method.

Based on good results with laboratory model of the hydraulic transformer Aurel Barglazan type located at Sanmartinul Sarbesc, a first industrial prototype TH-1 has been designed by specialists from the Polytechnic University and Mechanical Works Timisoara. Technology preparation and devices design was done in record time, seeing that this constructive solution is more robust, reliable and with improved energy performance versus the laboratory prototype.

Installing the type 1 hydraulic transformer called TH-1, at Sanmartinul Sarbesc (fig. 8), Timis county showed that conditions for new

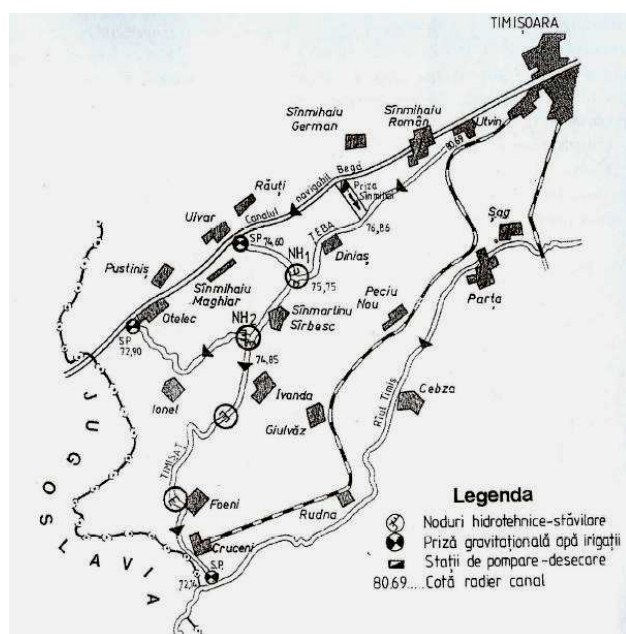

Figure 7 The drainage system Teba-Timisat, Romania

sites are already created. It is possible to install several groups working independently if the source flow allows it.

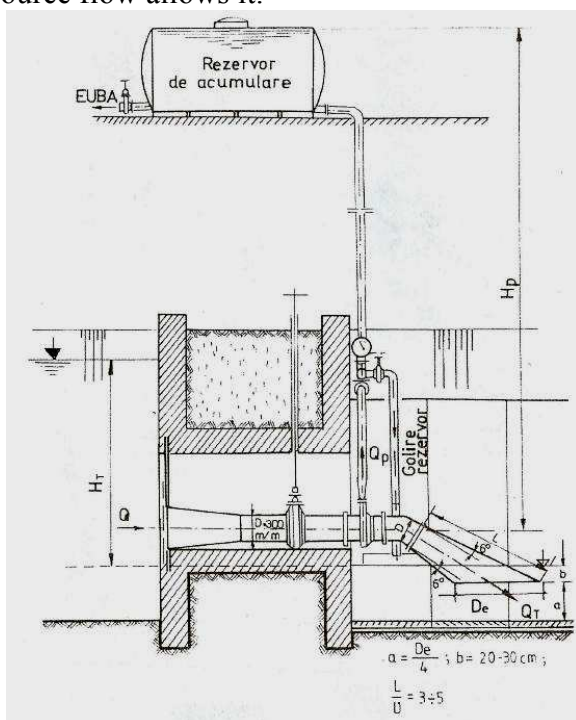

Figure 8 TH-1 Sanmartinul Sarbesc Romania

4.1.2 Pumping Microstation for Irrigation on Mills Channel at Ineu, Arad County

Mills Channel is a bypass channel of Crisul Alb river with the water intake in the Buteni town. It generally follows the level line, with a planimetry position, approximately parallel to the Crișul Alb river. Water abstraction was done by fitting a water intake on the left bank of the river, sized for a flow of 2.5 m³/s. A great place on the channel for a pumping microstation is the Mocrea mill, where there is a dam that regulates water levels upstream and has a level difference of 3.5 m from the discharge channel, (fig.9).

In figure 8 we can see the storage tank at about 4m above irrigation ground level with a leveling staff and flexible hose with the discharge diameter of 50mm. In this case the hydraulic transformer works very well, providing a pumping height of 8.4 m.

4.2 The Hydraulic Hammer

4.2.1 Pumping Microstation for Local Irrigation Arrangement Using the Hydraulic Hammer at Nicolint, Caras-Severin County, Romania

One of the pumping microstations for irrigation arrangements using the hydraulic pump (hydraulic hammer) type IEELIF - Resita is located in Nicolint, Caras-Severin county mounted in place of a water mill.



Figure 9 The pumping microstation Mocrea, Ineu, Arad county, Romania



Figure 10 Storage tank at about 4m above irrigation ground level with a leveling staff

The level difference used by the Nicolint village water mill was used to hydraulic pumping of water into a tower tank, needed in the local irrigation. The Nicolint microstation

is equipped with three hydraulic pumps with 600mm in diameter containers.

4.2.2 Demonstration Pumping Microstation Using the Hydraulic Hammer at the Drainage and Irrigation Laboratory, Hydrotechnical Engineering Faculty of Timisoara

The land reclamation laboratory from the Hydrotechnical Engineering Faculty Timisoara has made a stand for lab demonstration (fig.4), on which were studied adjustment problems of the evacuation throttle, depending on the length of the headrace available, measuring the pumping head, pump flow and will calculate the overall efficiency.

Currently, the new situation of private ownership of land, provides conditions for new pumping microstations to be made where irrigation is necessary and optimal hydraulic locations exist.

5. CONCLUSION

The two hydraulic machines ensure water pumping from river streams on which can be built or exist 1 – 4 m water drops, for local irrigations arrangements using low-head water energy.

The hydraulic transformer and hammer hydraulic pumps which were studied transform

the hydraulic energy into mechanical energy and then again into hydraulic energy at high hydraulic parameters, achieving a global efficiency of 10 – 50%.

The experimental research which was made at 1:1 scale proved their good function over time.

6. ACKNOWLEDGMENTS

This work was partially supported by the strategic grant POSDRU/89/1.5/S/57649, Project ID 57649 (PERFORM - ERA), co-financed by the European Social Fund – Investing in People, within the Sectorial Operational Programme Human resources Development 2007-2011.

7. REFERENCES

- [1] Anton I., M. Cozma, F. Gyulai, A. Wehry, M. Tamas, *Hydraulic transformer type "Barglazan", used in local irrigation arrangements*. "Hidrotehnica" journal no. 4/1990, Bucharest, 1990
- [2] Barglazan A., *Transformatorul hidraulic. Studiu teoretic si experimental. Phd. thesis no.2 1940*, "Politehnica" School of Timisoara, coordinator Prof. eng. Pompiliu Nicolau, 1940
- [3] Wehry A., *Local irrigation arrangements using unconventional energy*. Symposium "Ecological small hydro- power, social and economic impact", Timisoara, 1993
- [4] Wehry A., S. Guler, *Irrigation micro-pumping station using unconventional energy*. Ed. "Orizonturi Universitare", Timisoara 2002.