



POLITECNICO DI TORINO
Repository ISTITUZIONALE

Method and system for the automatic recognition of lesions in a set of breast magnetic resonance images

Original

Method and system for the automatic recognition of lesions in a set of breast magnetic resonance images / Vignati, Anna; Giannini, Valentina; Persano, Diego; Morra, Lia; Bert, Alberto. - (2009).

Availability:

This version is available at: 11583/2772294 since: 2019-12-09T23:54:10Z

Publisher:

Published

DOI:

Terms of use:

openAccess

This article is made available under terms and conditions as specified in the corresponding bibliographic description in the repository

Publisher copyright

(Article begins on next page)

(19) World Intellectual Property Organization
International Bureau



(10) International Publication Number
WO 2010/079519 A1

(43) International Publication Date
15 July 2010 (15.07.2010)

(51) International Patent Classification:
G06T 7/00 (2006.01)

(21) International Application Number:
PCT/IT2009/000005

(22) International Filing Date:
9 January 2009 (09.01.2009)

(25) Filing Language: Italian

(26) Publication Language: English

(71) Applicant (for all designated States except US): **IM3D**
S.p.A [WYT]; Via Principe Amedeo 12, 1-10123 TORINO (IT).

(72) Inventors; and

(75) Inventors/Applicants (for US only): **VIGNATI, Anna** [IT/IT]; Corso E. Gamba 39, 1-10144 TORINO (IT). **GI-ANNINI, Valentina** [IT/IT]; Via L. Cibrario 31/B, 1-10143 TORINO (IT). **PERSANO, Diego** [AR/AR]; Antartida Argentina 3866, A-HVHI665B Buenos Aires (AR). **MORRA, Lia** [WIT]; Via Bonino 20, 1-12042 BRA (Cuneo) (IT). **BERT, Alberto** [WIT]; Via G. Verdi 48, 1-12042 Bra (Cuneo) (IT).

(74) Agents: **DEAMBROGI, Edgardo** et al; c/o Jacobacci & Partners SpA, Corso Emilia 8, 1-10152 Torino (IT).

(81) Designated States (unless otherwise indicated, for every kind of national protection available): AE, AG, AL, AM, AO, AT, AU, AZ, BA, BB, BG, BH, BR, BW, BY, BZ, CA, CH, CN, CO, CR, CU, CZ, DE, DK, DM, DO, DZ, EC, EE, EG, ES, FI, GB, GD, GE, GH, GM, GT, HN, HR, HU, ID, IL, IN, IS, JP, KE, KG, KM, KN, KP, KR, KZ, LA, LC, LK, LR, LS, LT, LU, LY, MA, MD, ME, MG, MK, MN, MW, MX, MY, MZ, NA, NG, NI, NO, NZ, OM, PG, PH, PL, PT, RO, RS, RU, SC, SD, SE, SG, SK, SL, SM, ST, SV, SY, TJ, TM, TN, TR, TT, TZ, UA, UG, US, UZ, VC, VN, ZA, ZM, ZW.

(84) Designated States (unless otherwise indicated, for every kind of regional protection available): ARIPO (BW, GH, GM, KE, LS, MW, MZ, NA, SD, SL, SZ, TZ, UG, ZM, ZW), Eurasian (AM, AZ, BY, KG, KZ, MD, RU, TJ, TM), European (AT, BE, BG, CH, CY, CZ, DE, DK, EE, ES, FI, FR, GB, GR, HR, HU, IE, IS, IT, LT, LU, LV, MC, MK, MT, NL, NO, PL, PT, RO, SE, SI, SK, TR), OAPI (BF, BJ, CF, CG, CI, CM, GA, GN, GQ, GW, ML, MR, NE, SN, TD, TG).

Declarations under Rule 4.17:

- as to applicant's entitlement to apply for and be granted a patent (Rule 4.1 7(H))
- of inventorship (Rule 4A 7(iv))

[Continued on next page]

(54) Title: METHOD AND SYSTEM FOR THE AUTOMATIC RECOGNITION OF LESIONS IN A SET OF BREAST MAGNETIC RESONANCE IMAGES

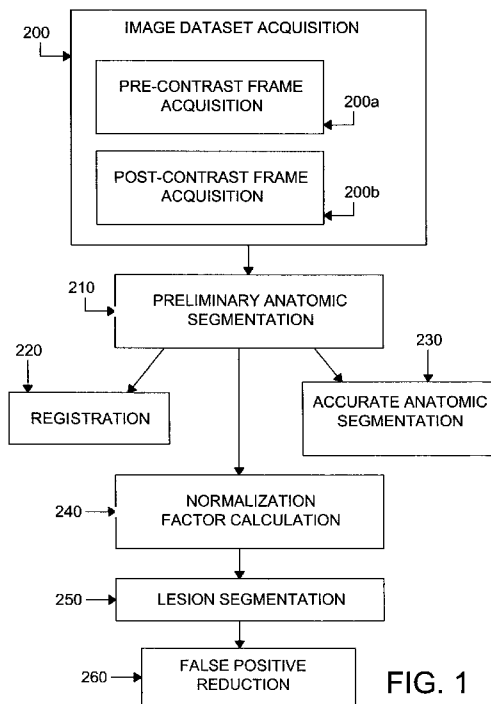

FIG. 1

(57) Abstract: A method of identification of potential lesions of a breast from tomographic image datasets of a chest region of a patient, the datasets comprising a plurality of voxels (2) each having an intensity value, the images including a region of interest (10) which comprises at least one breast (6). The method comprises the steps of: acquiring a set of images after the administration of a contrast agent to the patient; normalizing (254) the intensity of voxels (2) belonging to the region of interest (10) of the acquired images according to at least one normalization factor; classifying (255) each of the normalized voxels (2) on the basis of a classification criterion, in such a way as to identify regions (40) representing potential lesions. The method is characterized in that the normalization factor is based on normalization voxels (2) corresponding to an anatomical structure (34), the normalization voxels (2) having intensity values enhanced due to the administration of the contrast agent.

WO 2010/079519 A1

Published:

— with international search report (Art. 21(3))

Method and system for the automatic recognition of lesions in a set of breast magnetic resonance images

The present invention relates to a method of identification of objects and/or structures in magnetic resonance images.

More specifically, the invention relates to a digital segmentation method of the contents of an image of a breast, as defined in the preamble of claim 1.

In breast magnetic resonance imaging (MRI), a dataset comprising a plurality of tomographic images, each of them representing an axial, coronal or sagittal section of the patient's chest is acquired. In magnetic resonance images, the grey level intensity of each tissue depends on its chemical structure, in a way which reflects the specific acquisition protocol used.

In dynamic contrast enhanced MRI (DCE-MRI), a contrast agent bolus is injected intravenously, and a plurality of datasets are acquired at different time instants, in order to extract both anatomical and functional information. The presence of the contrast agent increases the local signal intensity, whereas the distribution of the contrast agent depends on the microcirculatory properties of each tissue. The contrast uptake is characterized by a kinetic as a function of the time, which is typically represented as a curve. As a result, the shape of this curve depends on the characteristics of the vascular systems of the lesions, which are known to be related with characteristics of the lesions themselves such as malignancy, prognosis and metastatic spread. Various acquisition protocols can be used to achieve this goal, with different results in terms of intensity distribution and signal-to-noise ratio.

For quantitative analysis of lesions in DCE-MRI, lesions of interest should be segmented. The term segmentation refers to the partitioning of an image into multiple regions in order to locate specific objects and/or features.

Manual segmentation is too time-consuming for being employed in clinical practice, and

suffers from inter- and intra-operator variability. Therefore, methods for semi-automatic or automatic segmentation of a lesion have been proposed. If the segmentation is performed in a totally automatic manner, the interaction of the operator, i.e. the radiologist, is reduced to the minimum and the system can also aid the radiologist in the detection of enhancing lesions.

Known solutions to perform an automatic segmentation of breast lesions still have drawbacks; for instance, they are limited in the type of images (resulting from different acquisition protocols) that can be successfully segmented, or require an initial input from the radiologist, such as the selection of a region of interest.

Object of the present invention is therefore to provide a method of segmentation which is capable of segmenting in an efficient, accurate and fully automatic manner the lesions present in the datasets of images of a breast, thus overcoming the limitations of the prior art.

This and other object are achieved by a method of segmentation having the characteristics defined in claim 1.

Particular embodiments of the invention are the subject of the dependent claims, whose content is to be understood as an integral or integrating part of the present description.

An identification system and a processing program as claimed form a further subject of the invention.

Further characteristics and advantages of the present invention will become apparent from the following description, provided merely by way of a non-limiting example, with reference to the enclosed drawings, in which:

- figure 1 is a flow chart of the operations performed by a method according to the invention;
- figures from Ia to Ie show altogether flow charts of the steps performed in different operations of figure 1;

- figure 2 is a schematic image of a breast section;
- figure 3 is a schematic lateral view of breasts;
- figure 4 is an example of a breast atlas;
- figure 5 represents typical trends of the contrast uptake in voxels belonging to malignant and benign lesions, as well as the typical average contrast uptake of an entire lesion; and
- figure 6 is a diagrammatic representation of a processing system for the implementation of the method according to the invention.

With reference to figure 1, a method according to the invention starts, at step 200, with the acquisition of magnetic resonance image datasets of a portion of a patient's body which comprises at least one breast, said portion being referred as sampled region. A dataset may comprise one or more images.

In the following description a reference coordination system is defined wherein a z axis is the longitudinal axis of the patient, and is oriented from the feet to the head, and the images represent sections of breasts on planes perpendicular to the z axis. Said planes are each defined by a couple of perpendicular axes denoted x and y in the following, wherein the x axis is the lateral axis, and is oriented from the left to the right of the patient, and the y axis is the anterior-posterior axis, and is oriented from the back to the belly of the patient.

In the following description, the term frame is used as a synonymous of the term dataset.

Step 200 comprises two succeeding steps: at step 200a a first dataset is acquired at a first time instant t_0 , said first dataset being in the following called pre-contrast frame. Subsequently, a contrast agent is administered to the patient by means of an intravenous injection and after that, at step 200b, a plurality of datasets in succeeding time instants t_1 , t_2 , ..., t_N is acquired, said datasets being in the following altogether called post-contrast frames.

In figure 2, a schematic image of a breast section is represented, such image comprising, in a known manner, a plurality of voxels, some of which have been represented as minuscule

squares indicated as a whole by the reference 2. Such voxels 2 have intensity values related to the properties of the corresponding tissue of the sampled volume. The reference 4 indicates the contour of the body of the patient, the reference 6 indicates two breasts, the reference 8 indicates a ribcage area, which comprises the ribcage and internal organs such as the lungs and the heart, and reference 10 indicates a region of interest which is the portion of clinical interest, said region of interest 10 including the breasts 6 and axillary regions 12.

In the following description of the method of the invention, all the operations are carried out with reference to the entire dataset of images, i.e. they are carried out three-dimensionally, unless otherwise specified.

Returning now to figure 1, a preliminary anatomic segmentation is performed in a step 210 in order to approximately locate the breasts 6 and determine their approximate size. More specifically, the approximate location is obtained by locating an infra-breast zone 14 (see figure 2) which is a zone of the sinus placed between the two breasts 6. This zone extends at most between a first breast terminal point 16 and a second breast terminal point 18. In a preferred embodiment only a reference point 20 is considered of said infra-breast zone 14, said reference point 20 being a point of the segment extending between the first breast terminal point 16 and the second breast terminal point 18, this reference point 20 being selected as disclosed herein below. When taking into account the whole dataset of images, said infra-breast zone 14 is a strip that corresponds to the skin placed on the sternum 21. According to the preferred embodiment above disclosed, only a line is considered of said strip, this line passing through the reference points 20 of each image.

The voxels 2 belonging to said infra-breast zone 14 are identified by recognizing voxels 2 placed between the breasts 6 and belonging to a surface external with respect to the contour 4 of the body of the patient as herein below disclosed.

Figure 1a shows a flow chart of the steps performed to carry out said step 210.

In order to carry out step 210, it is first necessary to individuate the contour 4 of the body

of the patient, i.e. the interface between the body of the patient and the air external to it. There are different ways to perform this step, all of them being based on the removal of the air external to the body of the patient. When the external air is removed, the first edge transition that is found scanning the images along the direction -y (see figure 2) is the contour 4 of the body of the patient.

At step 211 a combination of all post-contrast frames is calculated in order to take into account the whole dynamic series of datasets so as to minimize the effect of the acquisition noise due to presence of the air external to the patient's body. To perform such a combination, at each voxel 2 is assigned a new intensity value which is a predetermined combination function of the intensity values of the respective voxels 2 in each post-contrast frame.

The combination of the post-contrast frames is in the following denoted as "intensity projection" and the dataset of images obtained after said combination is called projected frame. The combination function is for instance the calculation of the mean of the intensity values, i.e. the intensity value of each voxel 2 of the projected frame is the mean of the intensity values of the respective voxels 2 in each post-contrast frame, thus obtaining a "mean projected frame". Alternatively, other types of combination functions can be used, for example the calculation of the minimum, or of the maximum or the median of the intensity values of the voxels 2.

At step 211 a first projected frame is calculated as above disclosed.

At step 212 a working region 22 (see figure 3) is extracted from the first projected frame by removing images that correspond, along the z axis, to portions of the sampled region too far from the breasts 6. In a preferred embodiment, the images corresponding to the upper 30% and to the lower 10% along the z axis of the sampled region are removed.

At step 213 transition zones between different structures contained in the images of the working region 22 of the first projected frame are identified by means of an edge detection filtering (e.g. gradient, laplacian, Sobel). In this way, a plurality of edges is obtained, each

edge distinguishing voxels 2 having different characteristics such as different intensity values. When taking into account the whole dataset of images, said edges are surfaces. Advantageously, a smoothing operation on the images is performed before applying the edge filter. Image smoothing allows to attenuate high frequency contents of the image, thus enhancing strong phase transitions. In a preferred embodiment, a gaussian smoothing filter is applied, for example with a standard deviation of 2.0mm, and a gradient magnitude filter is subsequently applied. -

At step 214 a main edge is identified within the plurality of edges found at step 213, said main edge substantially corresponding to the contour 4 of the body of the patient.

First, external air with respect to the patient's body is identified by means of a region growing procedure starting from voxels 2 placed out of the body of the patient, and therefore belonging to the external air. In a preferred embodiment a confidence connected region growing procedure is used, said procedure starting with the selection of a seed region comprising one or more voxels 2 placed out of the body of the patient. The voxels 2 that are for example selected are the voxels 2 placed in the top left corner of the images.

At the output of said region growing procedure the edge surface not recognized as air and having the biggest area corresponds to the transition between the air and the patient's body.

Alternatively, instead of performing steps 213 and 214, the individuation of the contour 4 of the body of the patient is performed by means of known intensity thresholding procedures: a threshold is determined, for example by means of the Otsu method, and is then applied to the images of the working region 22 of the first projected frame, so as to select voxels 2 having intensity values higher than a threshold value representative of the air. The interface between the selected voxels 2 and the other remaining voxels 2 of the image is the contour 4 of the body of the patient.

At step 215 the line which passes through the reference point 20 and represents the infra-breast zone 14 is calculated as herein below disclosed.

Each image of the working region 22 of the first projected frame is scanned along the -y direction, said scanning step beginning from the upper part of the image (in the y direction) in correspondence of the central point of the image along the x direction. The first point belonging to the contour 4 of the body of the patient reached in each image is the reference point 20, which has respective x and y coordinates. The line passing through the reference points 20 of each image represents the infra-breast zone 14.

At step 216 the scanning of the images of the working region 22 of the first projected frame is repeated, said scanning starting from all the points of the upper part of the images, along the x direction. The point having the maximum y coordinate (considering the y axis starting from the bottom part of each image) is denoted maximum breast point 24 and represents the point of maximum extension of the breasts 6.

Returning now to figure 1, at step 220 a registration procedure is performed between the post-contrast frames and the pre-contrast frame in order to correct possible misalignments among the frames composing the dynamic time series. Such misalignments can be caused by patient movements, breathing, cardiac motion and so forth. In this way, an alignment of all the post-contrast frames with the pre-contrast frame is performed.

The registration step 220 is performed for all voxels 2 preferably belonging to a working area 26, for all the frames or alternatively for only the images belonging to the working region 22.

The working area 26 is an area of each image smaller than the area of the whole image and that comprises the breasts 6. Said working area 26 is defined by fixing, in each image, a starting point having predetermined x and y coordinates. Preferably, said starting point is the reference point 20, i.e. in each image of the pre- and post contrast frames the voxel 2 having x and y coordinates equal to the coordinates of the reference point 20 is considered as the starting point. The working area 26 is created, for example, as a rectangular area delimited by a first line 28, parallel to the x axis, which runs above (in the y direction) the starting point of a first predetermined distance and a second line 30, parallel to the x axis, which runs below said starting point of a second predetermined distance. The term above

and below are herein referred to the figure 2 and indicate respectively positions having a y coordinate higher or lower. The working area 26 has a lateral extension, along the x direction, equal to the lateral dimension of the images.

The registration step 220 preferably comprises three sub-steps: a translation, a rigid-body transformation and a non-rigid transformation.

-

In all the sub-steps, a predetermined cost function based on an image similarity measure is used to compare the images, said function being the same for all the sub-steps or alternatively being different in each sub-step. For example, mutual information is used as image similarity measure, in particular the method specified by Mattes et al., "Non-rigid multimodality image registration", Medical Imaging 2001: Image Processing, pp. 1609-1620, 2001.

An example of non-rigid transformation is the Free-Form Deformation (FFD) model based on B-splines, as proposed in Ruecker et al., "Non-rigid registration using free-form deformations: application to breast MR images", IEEE Transactions on Medical Imaging, 18(8):712-721, 1999.

In the translation, in the rigid-body transformation and in the non-rigid transformation the respective cost functions are optimized by means of known optimizers. For example, a gradient descent optimizer is used for the translation and the rigid-body transformation; the LBFGSB (Limited memory - Broyden, Fletcher, Goldfarb and Shanno- for Bound constrained optimization) optimizer is used for the non-rigid transformation.

The images of the pre- and post-contrast frames have an original resolution along the x, y and z directions. In order to reduce the computing time, the following steps are performed.

If the original resolution is higher than a respective predetermined resolution, the images are down-sampled to said predetermined resolution. This is done according to the direction or directions in which the original resolution is higher than the predetermined one.

If the pre- or post-contrast frames present original resolution lower than said predetermined resolution, along the x, y and z directions, the registration is performed at the original resolution. Advantageously, said predetermined resolution is the same along the x, y and z directions.

The output of the registration step 220 is a first deformation field, one for each post-contrast frame, each first deformation field being a vector field wherein the vectors allow to match homologous points in the pre- and post-contrast frames. If the post-contrast frames were down-sampled before the registration, the respective first deformation fields are up-sampled to the original resolution.

After that, the working areas 26 of the original post-contrast frames are warped by applying to each post-contrast frame the respective first deformation field, i.e the voxels 2 are moved so that anatomical structures in the dataset have spatial distribution and relative spatial position corresponding to that of the pre-contrast frame, thus obtaining aligned post-contrast frames. When applying said first deformation fields, an interpolation is used. Advantageously, in order to minimize the introduction of sampling artifacts, the B-spline interpolation is used.

At the end of said registration step 220 a new set of post-contrast aligned frames is obtained. All the subsequent steps according to the invention are applied on said aligned post-contrast frames.

Alternatively, said registration step is omitted and all the subsequent steps according to the invention are applied on the post-contrast frames.

At step 230 an accurate anatomical segmentation is performed in order to more precisely extract different anatomical structures. The object of this step is to identify the voxels 2 belonging to the region of interest 10.

This object is achieved by adapting a breast atlas to the specific patient, more specifically by performing a registration between said atlas and a starting frame related to the pre- or

post-contrast aligned frames. In a preferred embodiment said starting frame is the pre-contrast frame. Alternatively, said starting frame is a second projected frame, different from the first projected frame and calculated as above disclosed by using the post-contrast aligned frames.

The registration between the atlas and the starting frame is performed by either warping the atlas or by warping the starting frame.

Said atlas is a reference dataset which represents a typical breast MRI dataset and is used to align the starting frame to a common reference anatomical space. Said atlas is therefore a set of images wherein each voxel 2 has a known intensity value. For example, the reference dataset can be a simplified, piece-wise constant representation of a real dataset, i.e. each voxel 2 of the atlas has a predetermined intensity value depending on the anatomical structure to which it belongs, where said intensity value is related to the average intensity observed in typical breast MRI datasets. The structures included in the reference dataset are not limited to the structures to be segmented, in order to provide sufficient information to successfully align the starting frame with the atlas. Alternatively, the known intensity values could be obtained by calculating the average of corresponding intensity values of images of real datasets, said real datasets being previously registered with one another. Advantageously, a smoothing filter is applied to said real datasets to remove unnecessary details.

The atlas is associated to a probability dataset, i.e. a set of images in which to each voxel 2 is associated at least one probability coefficient indicative of the probability that the voxel 2 belongs to one or more predetermined anatomical structures. Each voxel 2 may have either one discrete coefficient indicating whether the voxel 2 belongs to a predetermined anatomical structure or not, or a plurality of probability coefficients, each coefficient indicating the probability that the voxel 2 belongs to a respective anatomical structure. In the present invention, the probability coefficients are determined with reference to the region of interest 10, i.e. they represent the probability that a voxel 2 belongs to the region of interest 10.

In figure 4, an example of an image of a breast atlas is shown, representing a simplified version of a typical breast dataset.

Figure 1b shows a flow chart of the steps performed to carry out said step 230. Said step 230 is carried out only for the voxels 2 of the starting frame belonging to a working area, i.e. voxels 2 having x and y coordinates comprised in the area denoted working area 26.

-

At step 231 a predetermined atlas is selected as a function of the distance between the infra-breast zone 14 and the maximum breast point 24, said atlas being selected in a set of atlases corresponding to different breast dimensions. In a preferred embodiment, three atlases are defined, each having associated a respective probability dataset.

At step 232, the starting frame is down-sampled to remove unnecessary information and reduce the computational burden. Advantageously, the starting frame is also smoothed, for example by means of a gaussian or median filter, in order to remove unnecessary details and noise. Alternatively, this step may be omitted.

At step 233 a registration between the atlas and the starting frame is performed, as disclosed with reference to step 220. Preferably, the starting frame is kept fixed and the atlas is deformed. Alternatively, the atlas is kept fixed and the starting frame is deformed. The registration 233 begins with a translation step in which an infra-breast area of the atlas, whose position is known because it is determined during the creation of the atlas itself, is aligned with the infra-breast area 14 of the starting frame. If the starting frame is the pre-contrast frame or the second projected frame, the infra-breast area comprises voxels 2 having the same coordinates as those of the voxels 2 of the infra-breast area 14 calculated at step 215. The output of this step is a second deformation field.

At step 234, the probability dataset is used in order to segment the region of interest 10 as herein below disclosed.

If the starting frame is kept fixed and the atlas is deformed during the registration step 233, the probability dataset is aligned to the starting frame by warping it with the second

deformation field obtained at step 233. Alternatively, if the atlas is kept fixed and the starting frame is deformed, this step is omitted.

At this point at each voxel 2 of the working area 26 of the starting frame is associated a probability value representing the probability that said voxel 2 belongs to the region of interest 10, said probability value being equal to the probability coefficient of the respective voxel 2 of the probability dataset.

A voxel 2 is assigned to the region of interest 10 if its associated probability is higher than a predetermined threshold (e.g. 0.5). In an alternative embodiment, the probability dataset can be supplied as *a priori* probabilities to a known probabilistic classifier, such as an Expectation Maximization Model, arranged to classify each voxel 2 of the working area 26 of the starting frame by using features derived from the intensity value of the voxel 2 and the *apriori* probability that the voxel 2 belongs to the region of interest 10.

The result of step 234 is a binary mask in which a value of 1 or 0 is associated to each voxel 2 according to the fact that the voxel 2 belongs to the region of interest 10 or not, respectively.

Returning now to figure 1, at the subsequent step 240 at least one normalization factor is calculated in order to correct effects due to different acquisition modalities, different types and amounts of injected contrast agent and other possible factors like for example the technical characteristics of the scanner, which result in variations of image intensities between scanners, patients or even between different datasets from the same patient.

Advantageously, said normalization is based on the intensity values of anatomical structures always present in the field of view, such as the aorta 32 or the mammary arteries 34 (see figure 2). Firstly, the anatomical structures need to be identified and segmented; then, a normalization factor is extracted from the contrast uptake of the voxels 2 belonging to said anatomical structures. In a preferred embodiment, the mammary arteries 34 are employed, and the normalization is performed according to the steps shown in figure 1c.

Figure 1c shows a flow chart of the steps performed to carry out said step 240.

At step 241, a combination of the pre- and post-contrast aligned frames is calculated in order to enhance the intensity of said arteries 34, thus obtaining an intermediate frame. In fact, the arteries 34 comprise voxels 2 whose intensity values are increased by the presence of the contrast agent. Such intermediate frame could be obtained by assigning to each voxel 2 an intensity value equal to the subtraction between the intensity value of the respective voxel 2 in a predetermined post-contrast aligned frame and in the pre-contrast frame. Alternatively, at each voxel 2 is assigned an intensity value equal to the maximum intensity value of the respective voxel in the post-contrast aligned frames.

At step 242 an infra breast-sternum area 36 is identified for each image of the intermediate frame (see figure 2). This is an area comprised between the infra-breast zone 14 and sternum 21 and that includes said mammary arteries 34. For example, this is a rectangular area delimited by a first line, parallel to the x axis, which passes by the intra-breast zone 14, and a second line, parallel to the x axis, which runs below (along the y direction) said first line of a first predetermined quantity chosen so as to include the mammary arteries 34. The area is further delimited by two other lines, parallel to the y axis and placed at a predetermined distance, along the x axis, as to include only a predetermined central portion of the image, said central portion including the mammary arteries 34. For example, for each image of a working region of the intermediate frame, i.e. for the voxels 2 having the same coordinates as those of the voxels 2 belonging to the working region 22 calculated at step 212, a rectangle of 35mm x 100mm is considered by setting the y coordinate of a reference point, determined as disclosed with respect to the reference point 20 at step 215, as the midpoint of the higher side (along the y direction) of the rectangle itself.

At step 243 the mammary arteries 34 are identified. This is done by performing, in known manner, a vessel recognition procedure so as to identify tubular structures within the voxels 2 belonging to an infra breast-sternum region of the intermediate frame, said infra breast-sternum region being the tri-dimensional set of the infra breast-sternum area 36. For example, a Vessel Enhancing Filter is applied to the voxels 2 of the infra breast-sternum region. Alternatively, other method can be used to perform said identification. The output

of said Vessel Enhancing Filter is a measure of the "vesselness" of the local structure of each voxel 2, to which a vessel can be approximated. Voxels 2 whose vesselness value exceeds a predetermined threshold are classified as belonging to the mammary arteries 34. Preferably, said threshold is derived from the histogram of the result of the vesselness filter for all the voxels 2 belonging to the infra breast-sternum region 36. Examples of such threshold are half the maximum vesselness value, or the vesselness value corresponding to a predetermined percentile, such as the 95th percentile.

At the end of step 243, voxels 2 belonging to the mammary arteries 34 are recognized.

At this point the normalization factor is calculated based on the voxels 2 having the same coordinates as those of the voxels 2 belonging to the mammary arteries 34, either in the intermediate frame or in the second projected frame. Such normalization factor is, for example, the mean of the intensity values of the voxels 2. Alternatively, a plurality of normalization factors is calculated, each factor being calculated with reference to a different post-contrast aligned frame.

Returning now to figure 1, at step 250, the post-contrast aligned frames are processed in order to segment regions 40 corresponding to potential lesions.

It is known that curves representing the intensity of a voxel with respect to the time from the injection of a contrast agent can be classified in three categories. As shown in figure 5, references 500a and 500b indicate curves of the steady enhancement type, in particular 500a is a straight line while 500b is a curve. Reference 502 indicates a curve having a plateau of signal intensity, and reference 504 indicates a curve having a washout of signal intensity. Curves 500a and 500b are indicative of benign lesions, curve 502 is indicative of possible malignancy, and curve 504 strongly suggests malignancy.

Beyond this classification scheme, the shapes of the curves of the kinetic of the contrast uptake are subject to large physiologic variation, especially depending on differences in vascular permeability. Moreover, the curves 500a, 500b, 502 and 504 are referred only to individual voxels 2 or sets of contiguous voxels 2 (typically formed by a few voxels)

belonging to a single tissue having uniform vascular characteristics, and thus having uniform kinetics of the contrast uptake, whereas an average intensity curve calculated over an entire lesion (typically not having homogeneous vascular characteristics) is not necessarily discriminative. In figure 5, curve 506 is an example of said average intensity curve; as can be noted, curve 506 is quite different from the curves 500a, 500b, 502 and 504. In addition, it is known that there are parts of the lesions, such as the spiculations, that show contrast uptake only in the late frames acquired after the injection of the contrast agent.

Figure Id shows a flow chart of the steps performed to carry out said step 250.

In order to take into account the inhomogeneity of the contrast uptake, at step 251 at least one working dataset is calculated in order to exploit the information contained in the whole dynamic sequence acquired.

Such working dataset comprises voxels 2 to which are associated their respective intensities in the pre-contrast and post-contrast aligned frames. In particular, at each voxel 2 is associated a signal intensity curve representative of the intensity variation as a function of the time.

Preferably, in order to reduce the computational burden associated with processing all the post-contrast aligned frames, a combination of said post-contrast aligned frames, for example a maximum, median or mean intensity projection, is calculated and the working dataset comprises voxels 2 to which are associated their respective intensities in the intensity projection after subtracting their respective intensities in the pre-contrast frame. The subtraction is done in order to neglect the contribution of portions of the sampled region that do not show a contrast uptake after contrast injection.

At step 252, the anatomical mask obtained at step 234 is applied to said working dataset, so that the following steps are executed only for the voxels 2 belonging to the region of interest 10. Step 252 not only reduces the computational burden, but also avoids generating false positives (such as the heart, vessels or other regions comprised in the ribcage area 8)

which are placed out of the region of interest 10.

At step 253 a denoising filter such as median, an anisotropic diffusion or a gaussian filter is applied to said working dataset. Alternatively, this step is omitted.

At step 254, the intensity of each voxel 2 of the region of interest 10 of said working dataset is divided by one of the normalization factors obtained at step 240 thus obtaining a normalized working dataset. Alternatively, the post-contrast aligned frames are normalized before calculating the working dataset.

At step 255 each voxel 2 of the normalized working dataset is classified in one of two classes, which are potential lesion, or other. The classification must be performed in such a way so as to detect most of the voxels 2 showing a contrast uptake, and hence achieve a high sensitivity, while excluding the voxels 2 belonging to vessels. Since lesions are often connected to the supplying vessels, it is important that vessels are excluded at this step, as they might be segmented together with the lesions; over-segmentation could limit the performance of the subsequent steps and reduce the diagnostic quality of the segmentation.

In order to perform such classification, n variables are identified which characterize potential lesions, hereinafter termed "features". A n -dimensional vector is associated to each voxel 2 of the normalized working dataset, such n -dimensional vector containing the values of these features for the voxel 2 itself. In the following, said vectors of variables will be denoted "voxel feature vectors".

The features are extracted from the normalized working dataset and are indicative of the intensity (i.e. of the contrast uptake) and of the shape of the anatomical structure to which each voxel 2 belongs. Examples of features related to the intensity are the intensity value of the voxels 2 itself or of the neighbouring voxels 2, for example the first 26 voxels. Examples of features indicative of the shape are the vesselness values obtained by applying a vessel recognition procedure as above disclosed.

The voxel feature vectors belonging to each voxel 2 of the region of interest 10 are then

supplied to a known classifier which establishes to which class the corresponding voxel 2 belongs, as described hereinafter. Preferably, there are only two classes, i.e. potential lesion or other. The classifier can operate directly on the voxel feature vectors of the voxels 2. Alternatively, the classifier can be based on the combination of rules and hypotheses derived from *a priori* knowledge of the properties of lesions and normal tissues with rules drawn from the analysis of the voxel feature vectors themselves.

An example of a classifier which operates on the basis of the voxel feature vectors distinguishes the voxels 2 on the basis of a specific threshold for each feature. Advantageously, fixed thresholds T_1 and T_2 can be associated respectively to the intensity and to the vesselness values of the voxels 2 of the normalized working dataset: voxels 2 with intensity value higher than the first threshold T_1 and vesselness value lower than the second threshold T_2 are classified as belonging to potential lesions.

In another example, said classifier is constituted by a neural network with a specific structure and with parameters derived from the features of all voxels 2 through known methods of unsupervised training.

Other examples include classifiers of the *k-means* and *fuzzy c-means* type.

An example of classifier which integrates *a priori* knowledge regarding the characteristics of breast lesions is a classifier of the *fuzzy* type, which classifies each voxel 2 of the region of interest 10 according to predetermined rules.

The output of the classifier is a final dataset in which each voxel 2 of the normalized working dataset is either classified as belonging to a potential lesion or not. Said final dataset is further processed in order to extract regions 40 representing potential lesions, constituted by connected voxels 2 classified as belonging to a potential lesion.

The regions 40 may include not only malignant and benign lesions, but also vessels, lymph nodes and different kinds of false positives (such as motion artifacts and noise). Therefore, it is necessary to exclude from said detected regions 40 all the structures which are not of

clinical interest, i.e. to reduce the false positives.

This is performed in the final step 260 of the method according to the present invention, disclosed with reference to the flow chart of figure 1e.

At step 261 a vector of m features derived from the dimension, the kinetic, the position and the morphology of the region- 40, hereinafter denoted as "region feature vector", is associated to each region 40. The aim is to classify each region 40 in two or more classes according to its clinical interest. In a preferred embodiment, two classes are defined: lesions and non-lesions. Non-lesions can be further discriminated according to their nature (such as vessels, lymph nodes and other false positives). The features included in the region feature vector differ from those included in the voxel feature vectors as they characterize the global properties of a breast lesion as a whole, rather than the individual properties of each voxel 2 belonging to said breast lesion. This two-steps classification allows to exploit both high and low-level features of breast lesions in order to reduce the number of false positives.

An example of morphological feature is a vesselness measure of the region 40. A vesselness value is calculated for each voxel 2 as above disclosed, and then a single value for the feature is extracted combining the vesselness values of all voxels 2 of the region 40, for example by calculating the mean.

Kinetic features characterize time-signal intensity curves in order to identify trends different from those depicted in figure 5. An examples of such features is the standard deviation of the mean of the intensity values of the voxels 2 having coordinates corresponding to those of the voxels 2 of each region 40 at each acquisition time (of the post-contrast aligned frames), or the ratio between the mean of the intensity values of said voxels 2 at a predetermined time instant t_N and the corresponding value calculated at the preceding time instant t_{N-1} .

At step 262 a classifier is applied to said region feature vectors in order to distinguish the various classes of regions 40. The classification criteria are determined for example from a

priori knowledge of the characteristics of lesions, or by a comparison between the region feature vectors and corresponding vectors associated to known lesions extracted from a set of real exams.

An example of said classifier classifies the regions 40 applying a predetermined threshold to each feature of the region feature vector, where the thresholds can be fixed based on *a priori* knowledge of the characteristics of the lesions, or extracted from the vectors of the set of real exams. An example of threshold derived from *a priori* knowledge is a fixed threshold on the volume of the regions 40, as very small regions are probably non-lesions and furthermore lesions of very small size are not considered clinically significant.

Other examples of classifiers are linear classifiers, such as the Fisher's linear discriminant or non-linear classifiers, such as artificial neural networks or support vector machines.

Advantageously, said classifiers can be applied in cascade to the previously mentioned threshold-based classifier.

The method according to the invention is performed by a system of the type depicted in figure 5, which comprises a workstation 500, of known type, having an elaborating subsystem 510, a display 520, a keyboard 530, a mouse 540 and a device for connection to a local network (network bus) 550. Alternatively, the elaborating system can be of a distributed type (not shown) having an elaborating subsystem and input/output peripheral drives, local or remote. The workstation 500 or the distributed system are arranged to elaborate groups or modules of programs stored on a disk 560 or accessible through a network, to display the method described, and to display the results obtained. Said solution here mentioned are considered well known in the art and will not be further described because they are not relevant for the understanding and carrying out of the present invention.

Clearly, the principle of the invention remaining the same, the embodiments and the details of production can be varied considerably from what has been described and illustrated purely by way of non-limiting example, without departing from the scope of

protection of the present invention as defined by the attached claims.

CLAIMS

1. Method of identification of potential lesions of a breast from tomographic image datasets of a chest region of a patient, said images comprising a plurality of voxels (2) each having an intensity value, said images including a region of interest (10) which comprises at least one breast (6); the method comprising the steps of:

- acquiring a set of images after the administration of a contrast agent to the patient;
- normalizing (254) the intensity of voxels (2) belonging to the region of interest (10) of said acquired images according to at least one normalization factor;
- classifying (255) each of said normalized voxels (2) on the basis of a classification criterion, in such a way as to identify regions (40) representing potential lesions;

the method being characterized in that the normalization factor is based on normalization voxels (2) corresponding to an anatomical structure (34), said normalization voxels (2) having intensity values enhanced due to the administration of the contrast agent.

2. The method according to claim 1, further comprising the steps of:

- acquiring (200, 200a, 200b) a first dataset of images before the administration of the contrast agent to the patient and a plurality of second subsequent datasets of images after the administration of said contrast agent;
- performing (230) an anatomical segmentation of at least one dataset in order to identify voxels (2) which belong to said region of interest (10);
- calculating (251) a working dataset based on the first dataset and on the plurality of second dataset, said working dataset comprising working voxels (2) associated with their respective intensity values in the first dataset and in the plurality of second datasets;
- identifying (252) the working voxels (2) which have the same coordinates of the voxels (2) which belong to said region of interest (10) as identified in the anatomical segmentation, whereby the normalization (254) is performed on said working voxels (2) according to the at least one normalization factor;

the method being characterized in that the normalization factor is obtained by:

- calculating (241) an intermediate dataset as a combination of the first dataset and at least one of said second datasets;
- identifying (243) in said intermediate dataset a plurality of intermediate voxels (2) corresponding to the anatomical structure (34), said intermediate voxels (2) having

intensity values enhanced due to the administration of the contrast agent.

- calculating said normalization factor based on normalization voxels (2) having the same coordinates of the intermediate voxels (2) corresponding to said anatomical structure (34), wherein the normalization voxels (2) are associated to the voxels (2) of the plurality of second datasets of images having the same coordinates of the intermediate voxels (2) corresponding to said anatomical structure (34).

-

3. The method according to claim 2, further comprising the step of registering (220) the plurality of second datasets and the first dataset to obtain a plurality of aligned datasets.

4. The method according to claim 2 or 3, wherein the step of performing (230) an anatomical segmentation comprises the steps of:

- defining a reference dataset based on the first dataset or on a predetermined combination of the plurality of second datasets;
- selecting (23 1) a predetermined breast atlas;
- associating a predetermined probability dataset to said breast atlas, said probability dataset being a dataset in which to each voxel (2) is associated at least one probability coefficient indicative of the probability that the voxel (2) belongs to the region of interest (10);
- registering (233) said atlas and the reference dataset;
- using (234) the probability dataset in order to identify voxel (2) of the reference dataset which belong to the region of interest (10).

5. The method according to claim 4, wherein said probability coefficient is discrete.

6. The method according to claim 4, wherein said probability coefficient is a plurality of probability coefficients.

7. The method according to any of the claims 4 to 6, further comprising the steps of:

- identifying (2 10) in said plurality of second datasets an infra-breast zone (14);
- identifying (216) a maximum breast point (24) which represents the point of maximum extension of the breast (6);

- selecting (231) the breast atlas as a function of the distance between the infra-breast zone (14) and the maximum breast point (24).

8. The method according to claim 7, wherein the step of identifying (216) a maximum breast point (24) comprises the steps of:

- identifying a contour (4) of the body of the patient;
- identifying (216) said maximum breast point (24) as a predetermined point of said contour (4).

9. The method according to any of the claims 2 to 8, wherein the step of calculating (241) an intermediate dataset comprises the steps of assigning to each voxel (2) an intensity value equal to the subtraction between the intensity value of the respective voxel (2) in a predefined second dataset and in the first dataset.

10. The method according to any of the claims 2 to 9, wherein the step of identifying (243) in said intermediate dataset voxels (2) corresponding to the anatomical structure (34) comprises the step of identifying tubular structures which correspond to mammary arteries (34) of the patient.

11. The method according to any of the claims 2 to 10, wherein said normalization factor is the mean of the intensity values of the normalization voxels (2).

12. Identification system of potential lesions of a breast arranged to perform the method as claimed in any of the claims 1 to 11.

13. Processing program or program group executable by a processing system comprising one or more code modules for carrying out the method of identification of potential lesions of a breast as claimed in any of the claims 1 to 11.

FIG. 1

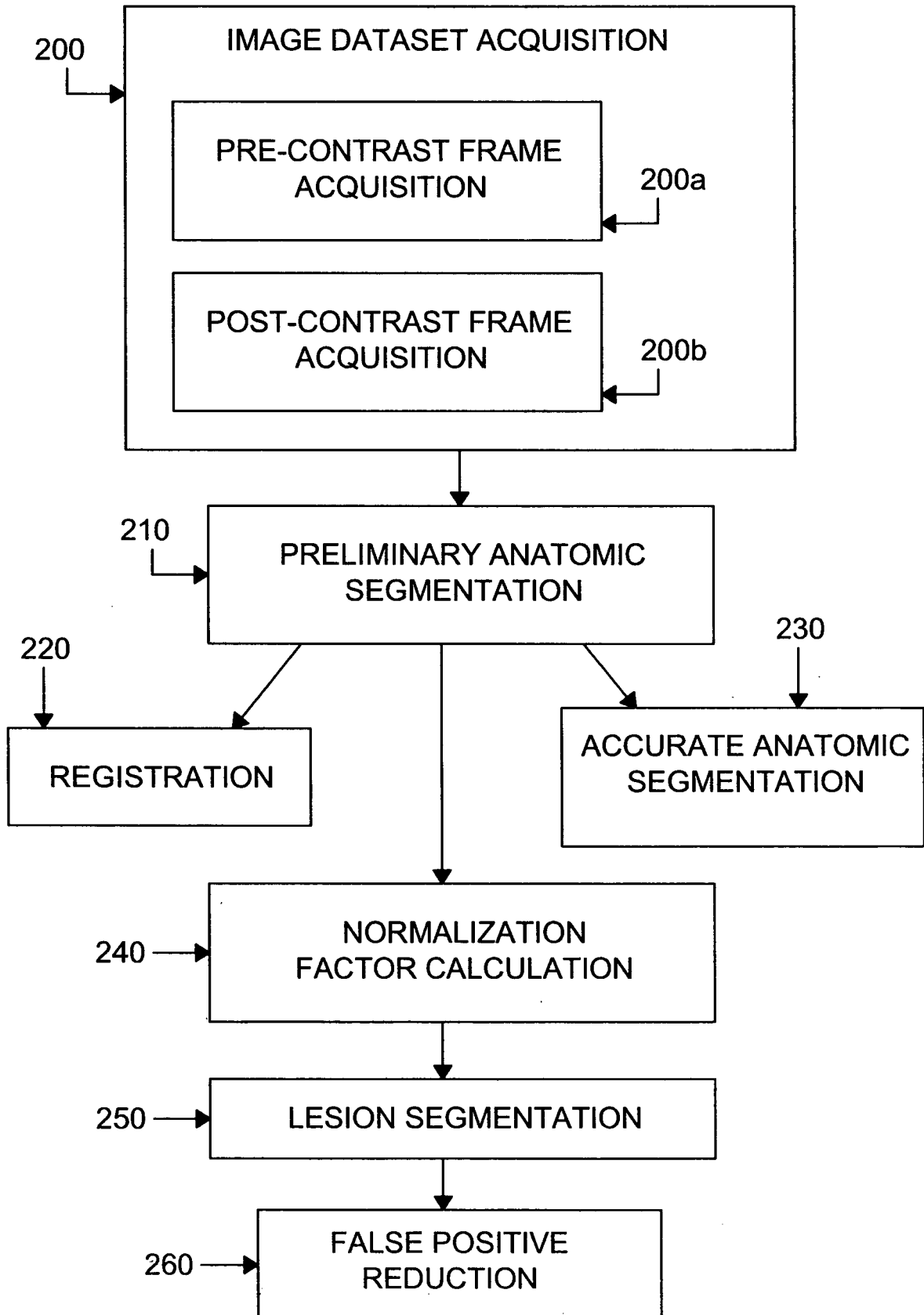

FIG. 1a

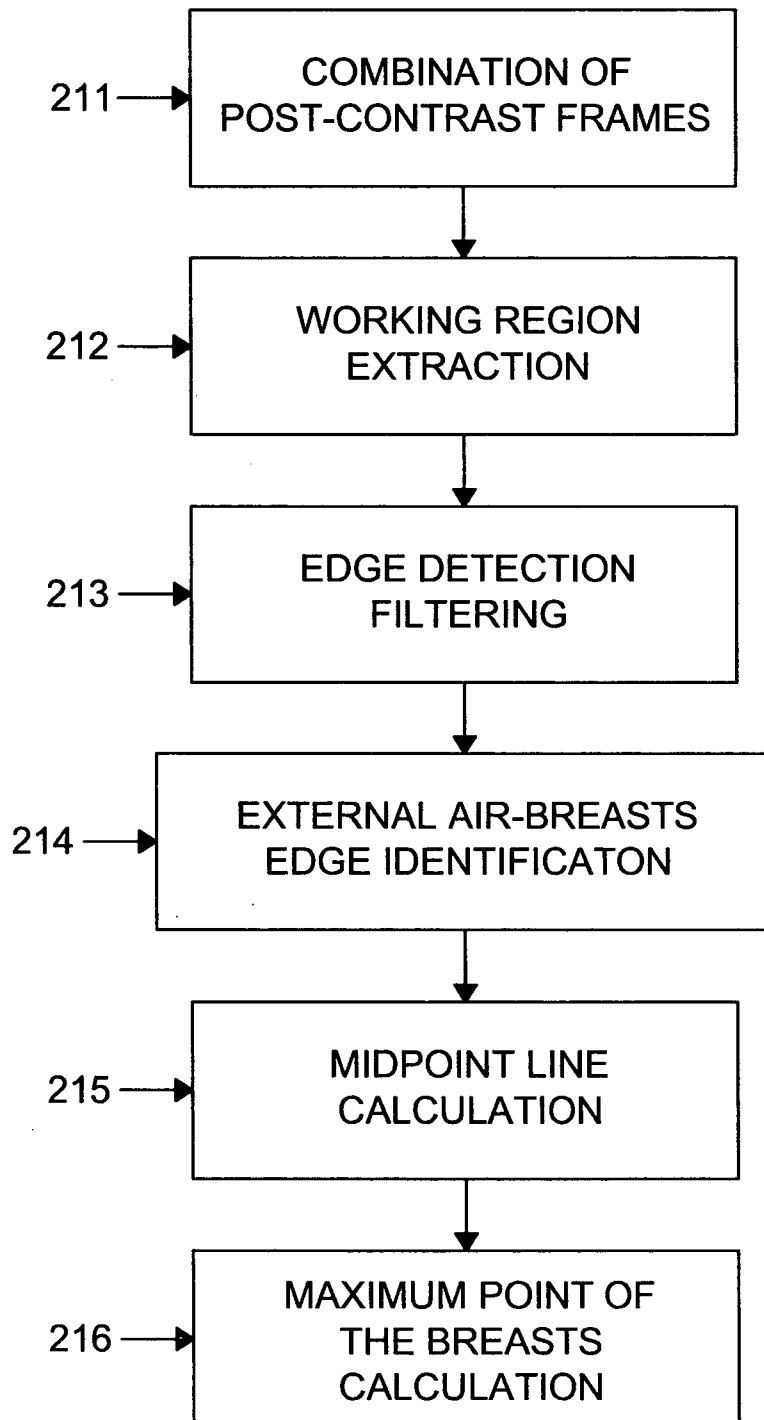

FIG. 1a

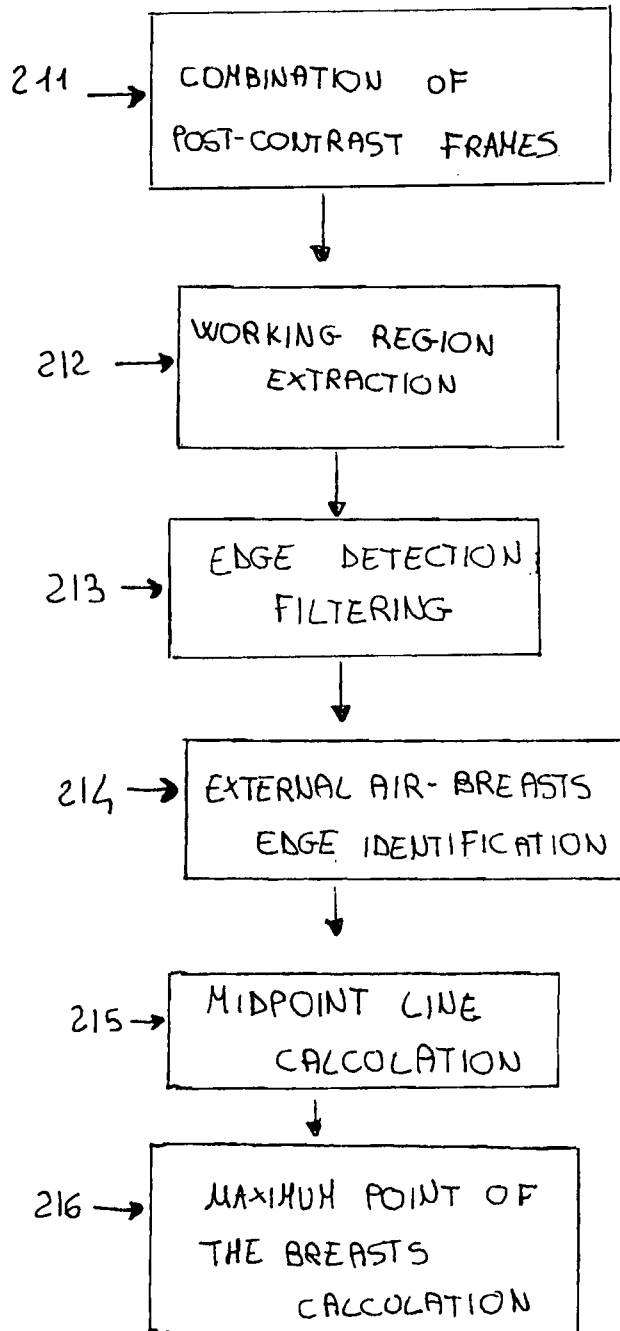

FIG. 1b

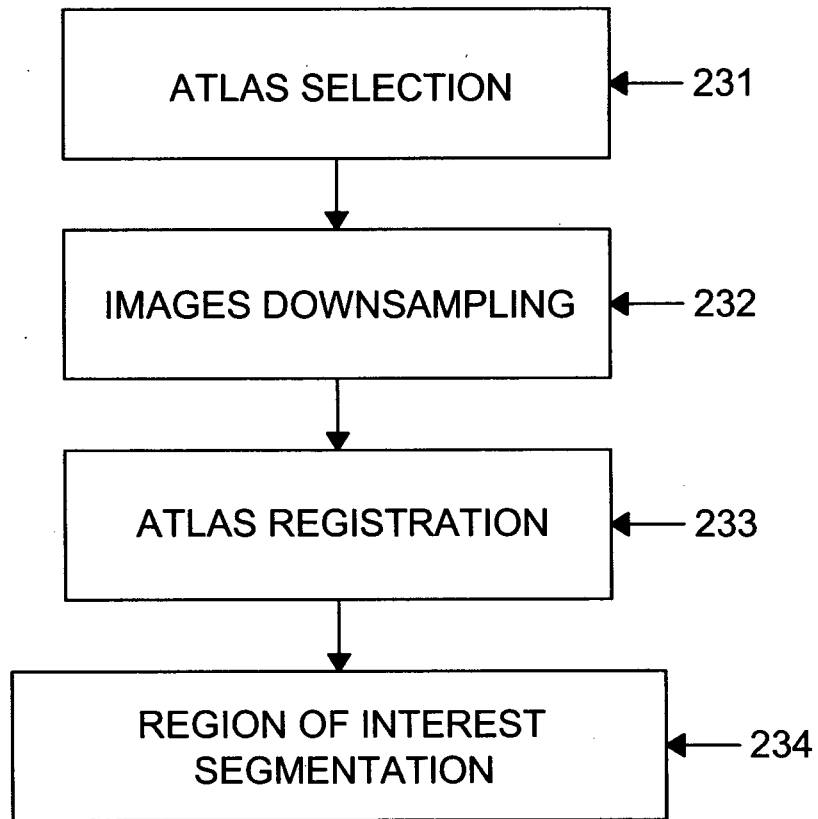

FIG. 1c

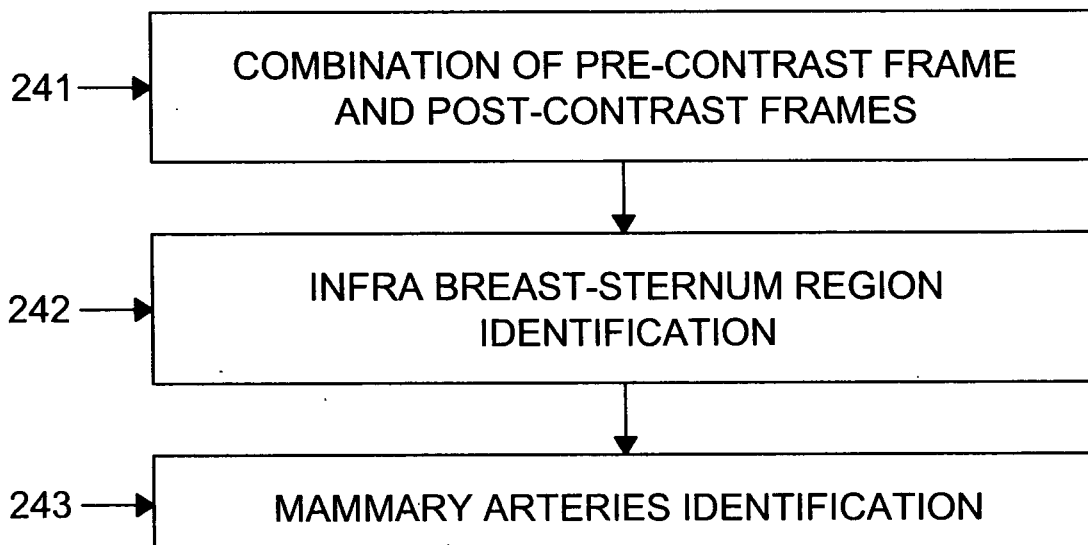

FIG. 1b

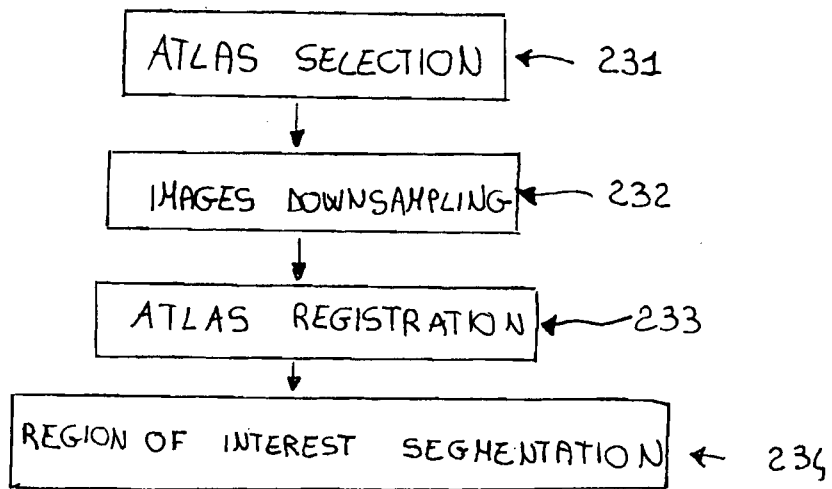

FIG. 1c

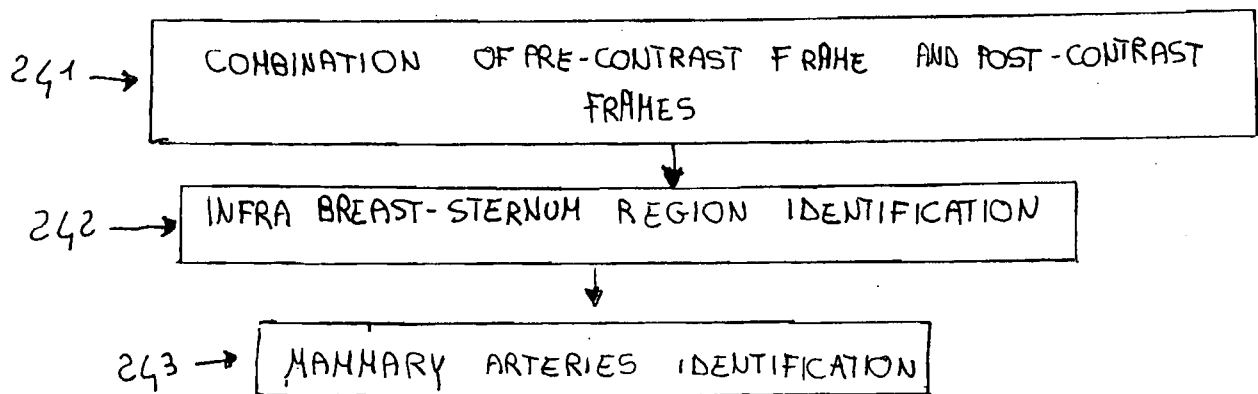

FIG. 1d

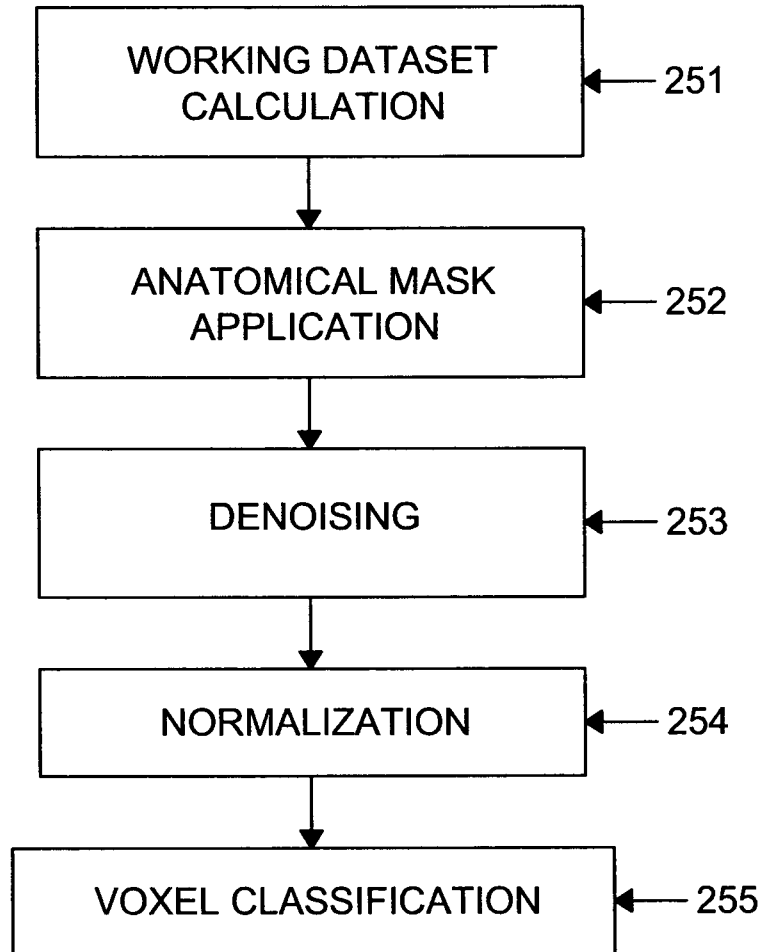

FIG. 1e

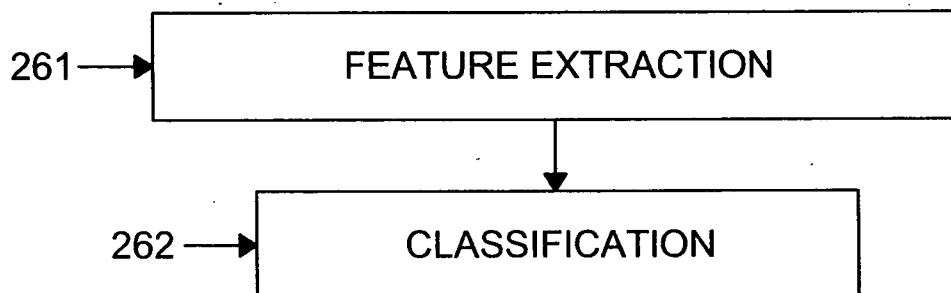

FIG. 1d

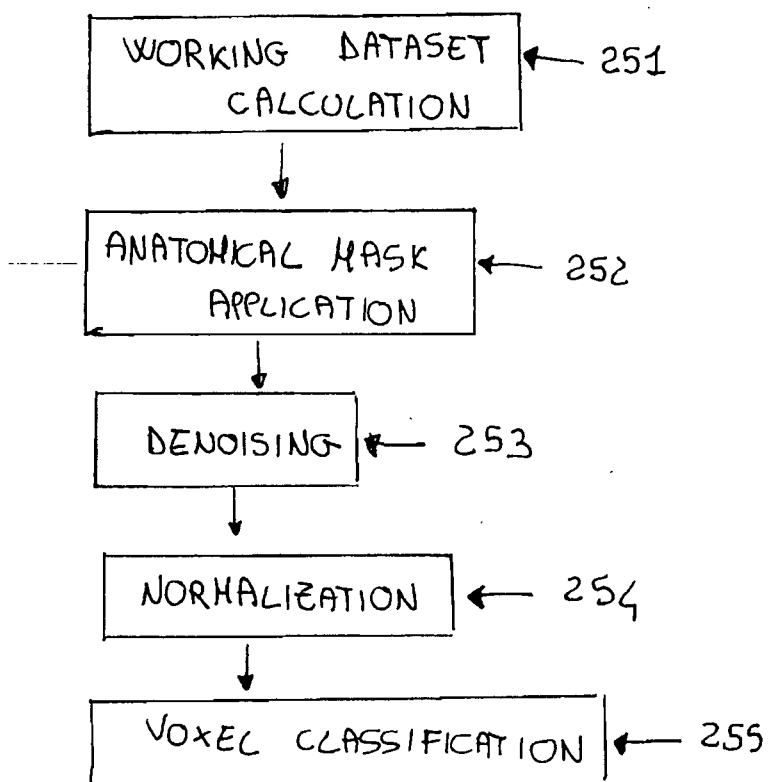

FIG. 1e

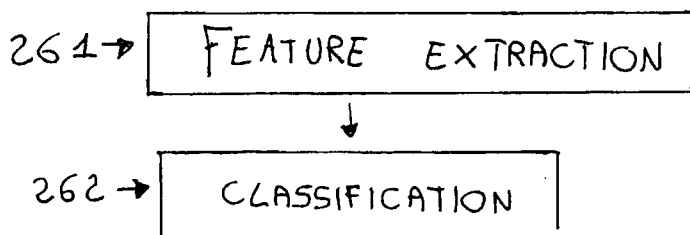

FIG. 2

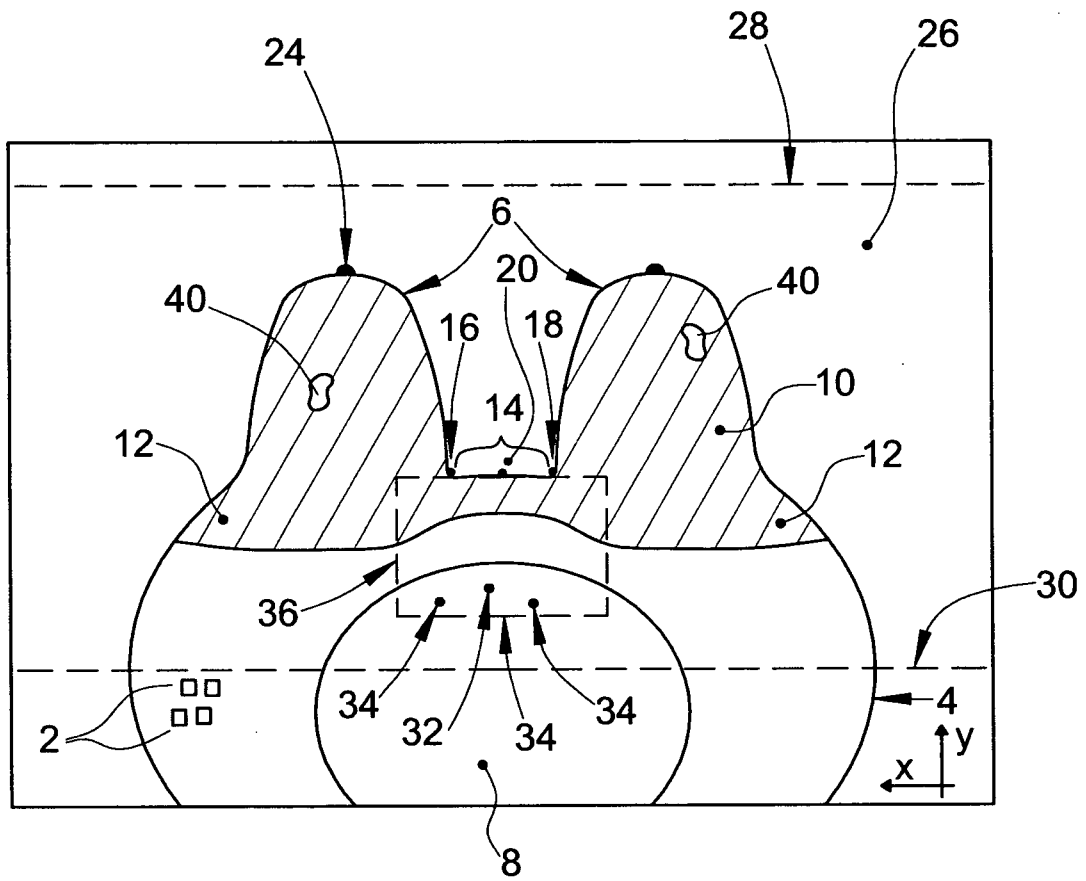

FIG. 2

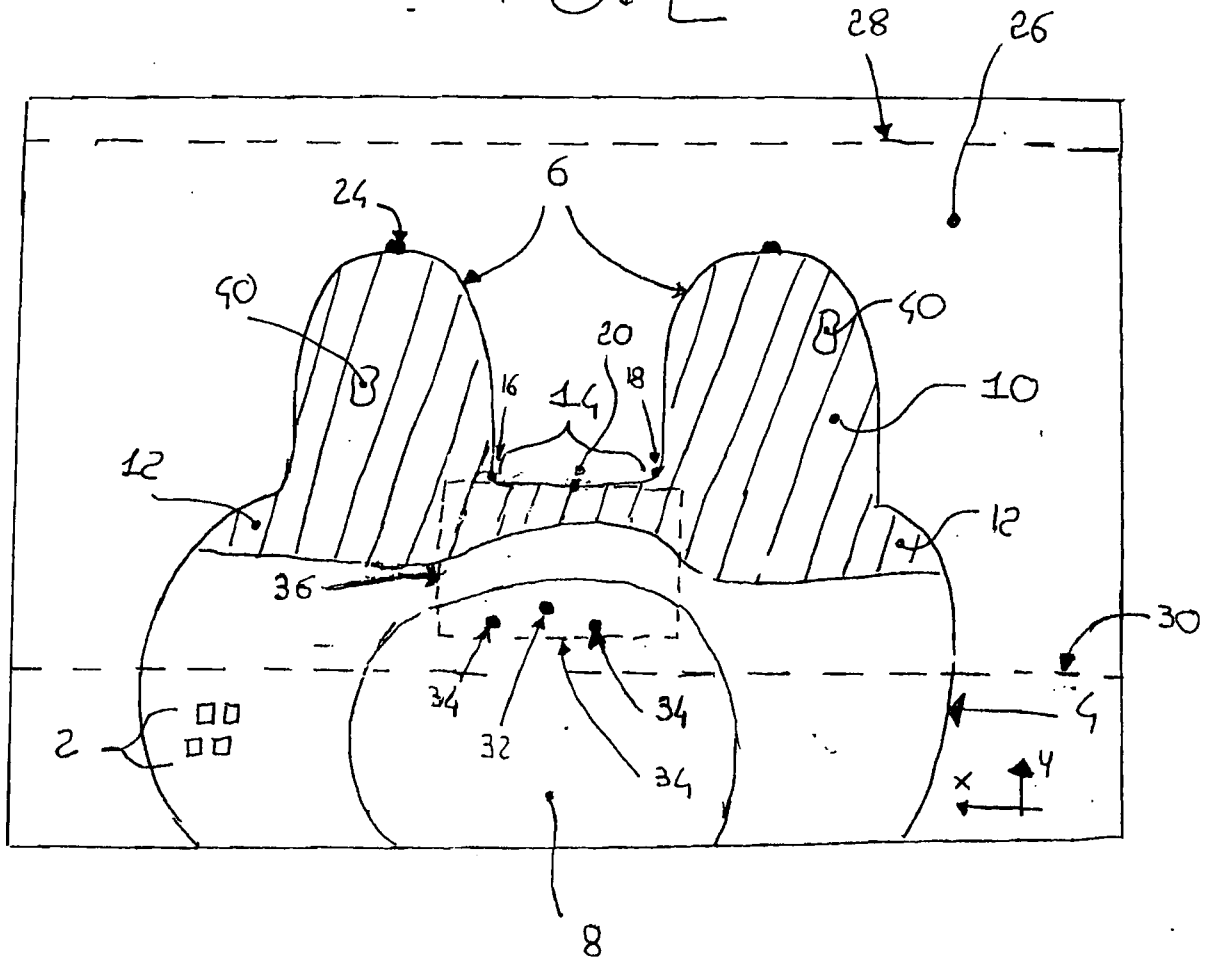

FIG. 3

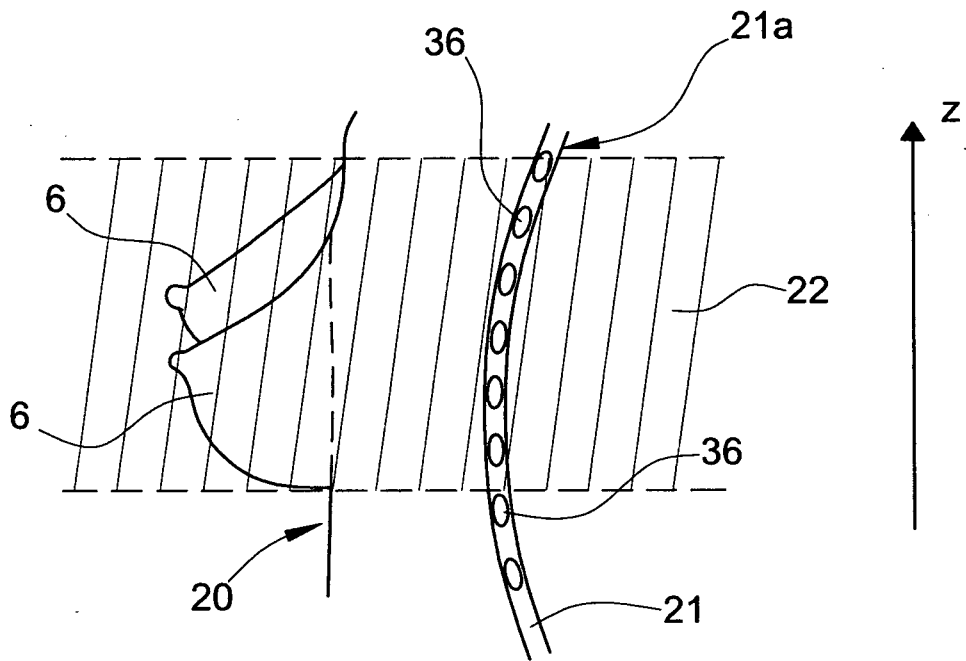

FIG. 4

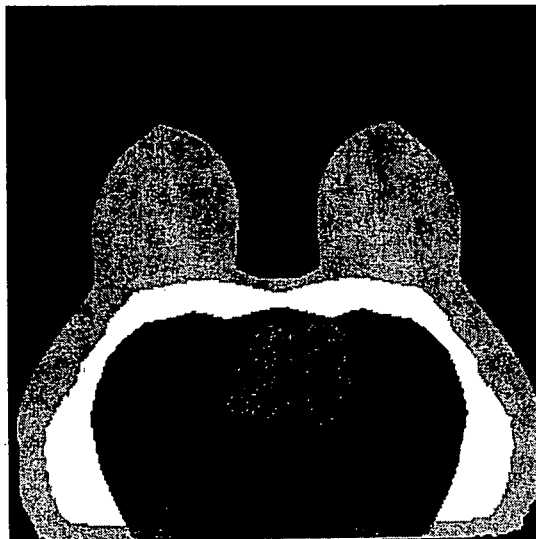

FIG. 3

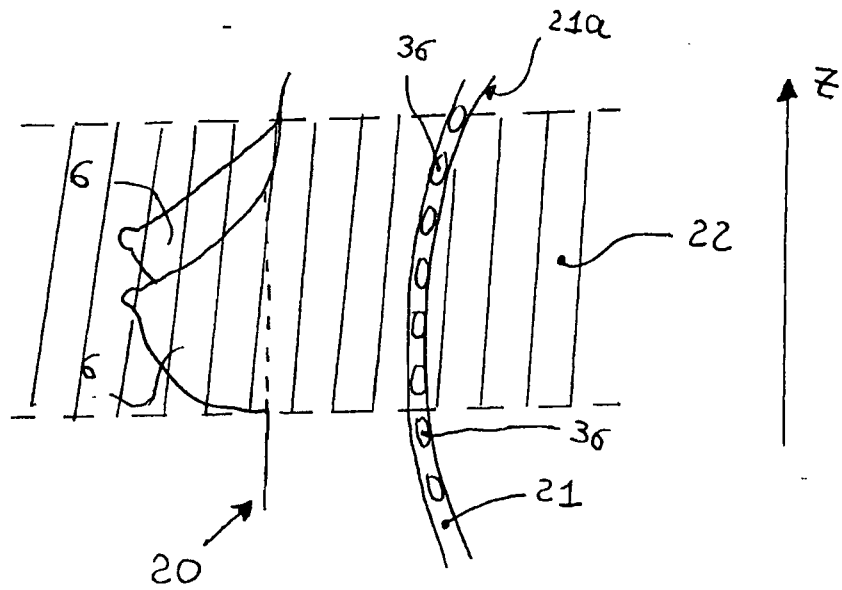

FIG. 4

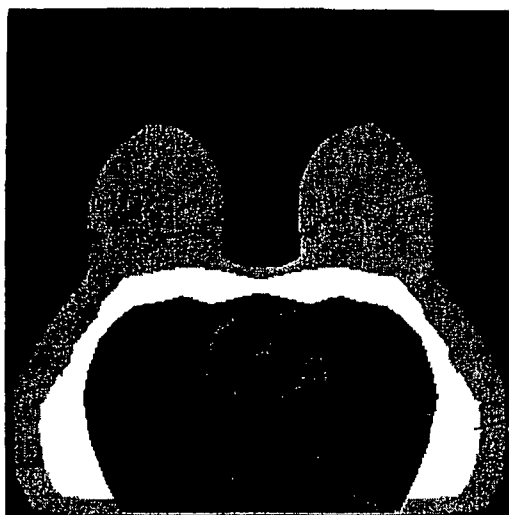

FIG. 5

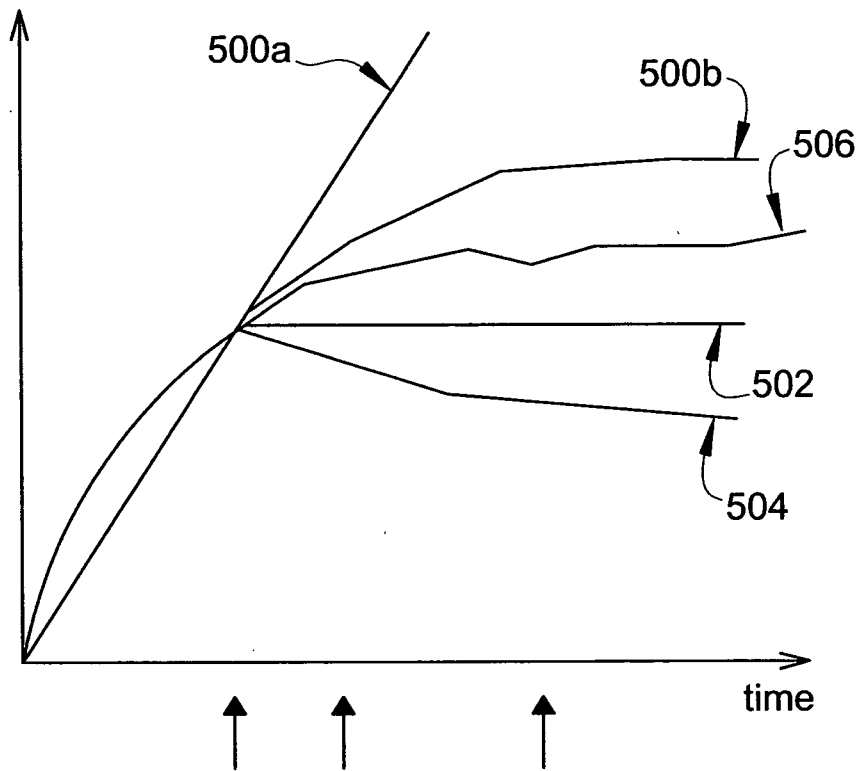

FIG. 5

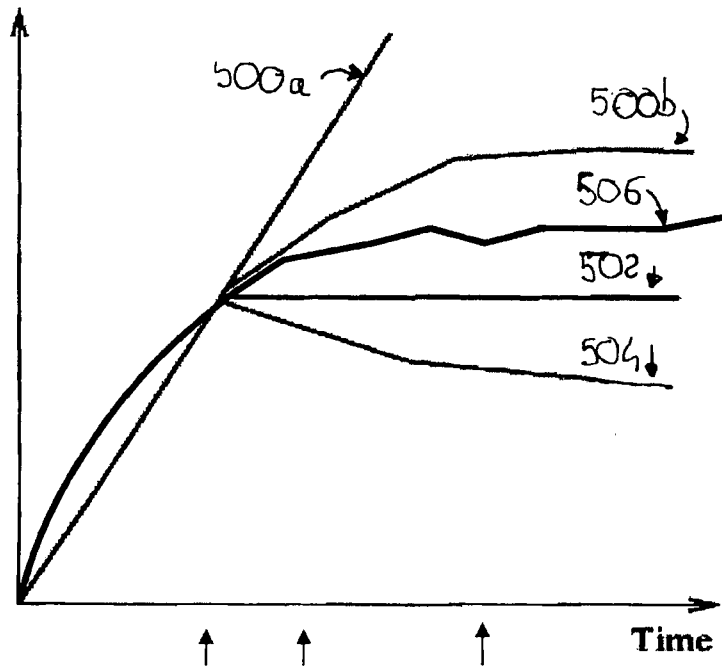

FIG. 6

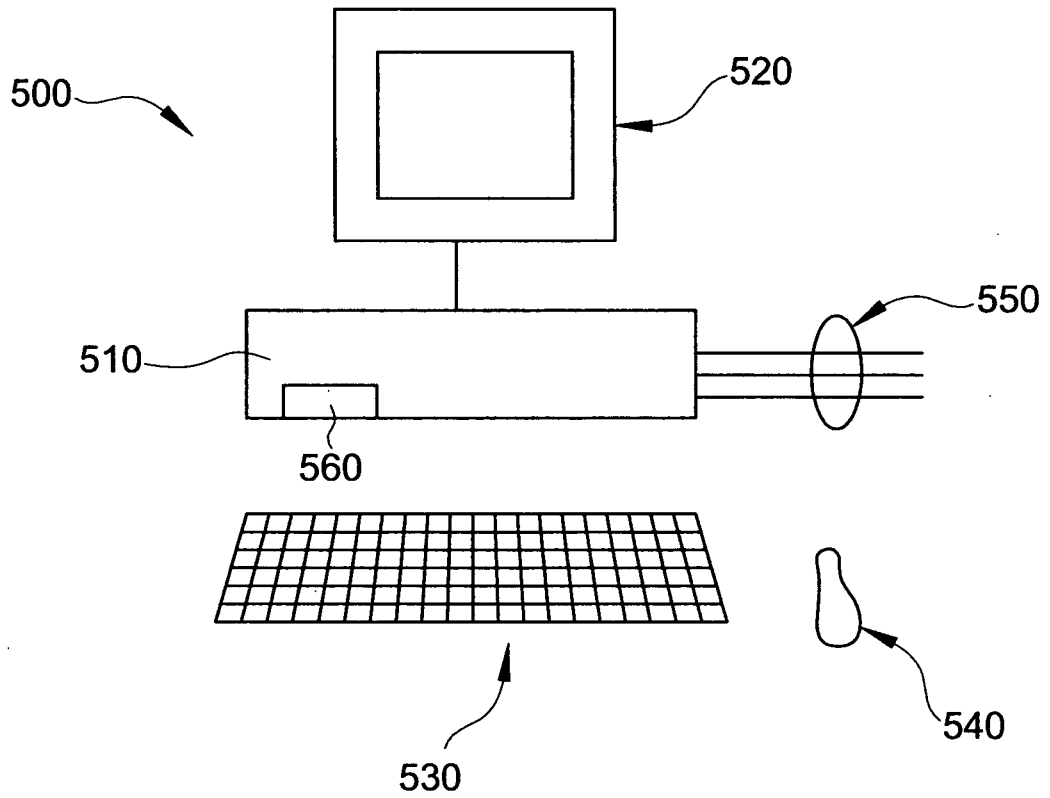
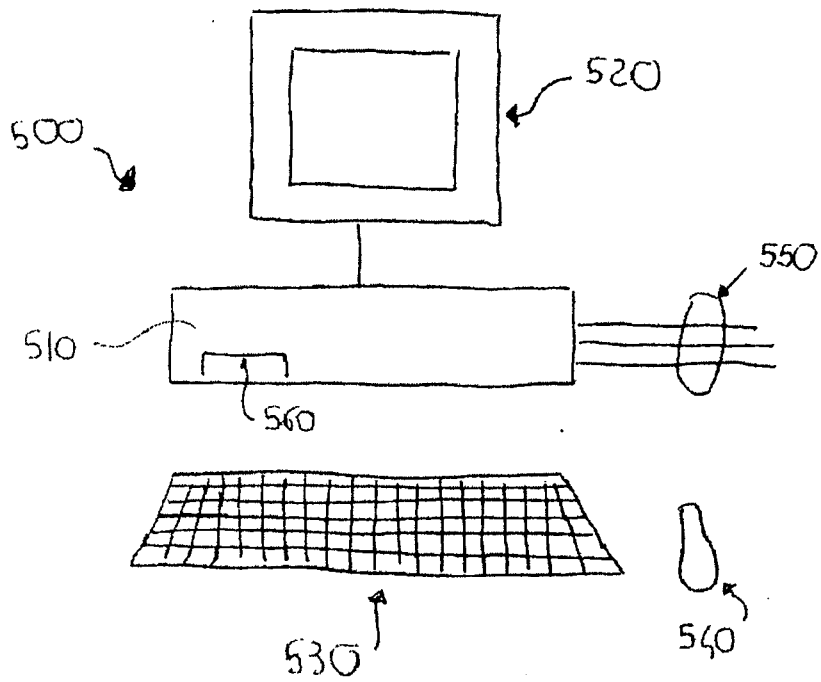

FIG. 6



INTERNATIONAL SEARCH REPORT

International application No
PCT/IT2009/000005

A. CLASSIFICATION OF SUBJECT MATTER
INV. G06T7/00

According to International Patent Classification (IPC) or to both national classification and IPC

B. FIELDS SEARCHED

Minimum documentation searched (classification system followed by classification symbols)
G06T

Documentation searched other than minimum documentation to the extent that such documents are included in the fields searched

Electronic data base consulted during the international search (name of data base and, where practical, search terms used)

EPO-Internal, WPI Data, PAJ, INSPEC

C. DOCUMENTS CONSIDERED TO BE RELEVANT

Category*	Citation of document, with indication, where appropriate, of the relevant passages	Relevant to claim No
X	WO 2007/059615 A1 (MEDIPATTERN CORP [CA]; COLLINS JEFFREY [CA]; LACHMANN FREDERIC [CA]; s) 31 May 2007 (2007-05-31) paragraph [0081] - paragraph [0086]	1, 12-13
A	WO 2007/062135 A2 (SHIRAISHI JUNJI [US]; DOI KUNIO [US]; APPELBAUM DANIEL [US]; LI QIANG) 31 May 2007 (2007-05-31) page 6, line 30 - page 7, line 4	1-13

D Further documents are listed in the continuation of Box C

See patent family annex

* Special categories of cited documents

'A' document defining the general state of the art which is not considered to be of particular relevance

'E' earlier document but published on or after the international filing date

'L' document which may throw doubts on priority claim(s) or which is cited to establish the publication date of another citation or other special reason (as specified)

'O' document referring to an oral disclosure, use, exhibition or other means

'P' document published prior to the international filing date but later than the priority date claimed

'T' later document published after the international filing date or priority date and not in conflict with the application but cited to understand the principle or theory underlying the invention

'X' document of particular relevance, the claimed invention cannot be considered novel or cannot be considered to involve an inventive step when the document is taken alone

'Y' document of particular relevance, the claimed invention cannot be considered to involve an inventive step when the document is combined with one or more other such documents, such combination being obvious to a person skilled in the art

'&' document member of the same patent family

Date of the actual completion of the international search

15 December 2009

Date of mailing of the international search report

21/12/2009

Name and mailing address of the ISA/

European Patent Office, P B 581 8 Patentlaan 2
NL - 2280 HV Rijswijk
Tel (+31-70) 340-2040,
Fax (+31-70) 340-3016

Authorized officer

Chateau, Jean-Pierre

INTERNATIONAL SEARCH REPORT

Information on patent family members

International application No

PCT/IT2009/000005

Patent document cited in search report	Publication date	Patent family member(s)	Publication date	
WO 2007059615	A1	31-05-2007	AU - 2006317424 A1	31-05-2007
			CA 2629727 A1	31-05-2007
			CN 101360453 A	04-02-2009
			EP 1951117 A1	06-08-2008
			JP 2009516551 T	23-04-2009
			KR 20080070767 A	30-07-2008
<hr/>				
WO 2007062135	A2	31-05-2007	US 2008298657 A1	04-12-2008