

SERBIAN JOURNAL OF ELECTRICAL ENGINEERING
VOL. 6, No. 2, November 2009, 299-313

UDK: 621.314.57:004.052.4

Neural Network Based PWM AC Chopper Fed Induction Motor Drive

Jamuna Venkatesan¹, Rama Reddy Sathi¹

Abstract: In this paper, a new Simulink model for a neural network controlled PWM AC chopper fed single phase induction motor is proposed. Closed loop speed control is achieved using a neural network controller. To maintain a constant fluid flow with a variation in pressure head, drives like fan and pump are operated with closed loop speed control. The need to improve the quality and reliability of the drive circuit has increased because of the growing demand for improving the performance of motor drives. With the increased availability of MOSFET's and IGBT's, PWM converters can be used efficiently in low and medium power applications. From the simulation studies, it is seen that the PWM AC chopper has a better harmonic spectrum and lesser copper loss than the Phase controlled AC chopper. It is observed that the drive system with the proposed model produces better dynamic performance, reduced overshoot and fast transient response.

Keywords: PWM AC Chopper, Modeling of Single-phase Induction Motor, Total Harmonic Distortion, Closed loop control, Neural Network Controller.

Nomenclature

- E_a Pulse width modulated voltage [V]
- I_1 Current flowing through the stator [A]
- ω Angular speed [rad/s]
- $\Delta\omega$ Error in angular speed [rad/s]
- I/P Input layer
- H/L Hidden layer
- O/P Output layer
- s Slip
- r_1 Stator resistance [Ω]
- r_2 Rotor resistance referred to stator [Ω]

¹Electrical and Electronics Engineering Department, Jerusalem College of Engineering, Chennai, India;
E-mail:

r_0	Equivalent resistance corresponding to the iron losses [Ω]
L_1	Leakage inductance of stator [H]
L_2^1	Leakage inductance of rotor referred to stator [H]
L_0	Magnetizing inductance of the stator [H]
x_1	Leakage inductive reactance of stator [Ω]
x_2^1	Leakage inductive reactance of rotor referred to stator [Ω]
x_0	Magnetizing inductive reactance of the stator [Ω]
V	Input voltage [V]
V_0	Output voltage [V]
V_1	Voltage across the variable rotor resistance [V]
I_0	iron-loss and magnetizing component of the no-load current [A]
I_2^1	Rotor current referred to the stator [A]
T	Torque [Nm]
n_s	Synchronous speed in [rps]
J	Moment of inertia in [kgm^2]
B	Viscous friction in [Nms]
P	Poles
θ	Angular displacement in radians
Y	Output vector of the hidden layer
O	Output vector of the output layer
V_{ji}	weight matrix
W_{kj}	weight matrix
B_1	Bias vector
B_2	Bias vector
X	Input

1 Introduction

The single phase induction machine is widely used in industry because of its simple construction, reliable operation, lightness and cheapness. The speed control of such motors can be achieved by controlling the applied voltage on the

motor by the use of power electronic devices. An AC voltage regulation is used to control the output AC voltage for power ranges from a few watts upto a fraction of megawatts. Traditionally, phase angle control and Integral cycle control of thyristors are used in AC voltage regulators. They suffer from inherent disadvantages such as retardation of the firing angle, lagging power factor at the input side, and high lower-order harmonic contents in both load and supply voltages and currents.

Recent developments in power electronics make it possible to improve the power system utility interface. A developed control strategy for firing instances in pulse width modulated AC voltage regulators is presented in [1]. Line commutated AC controllers can be replaced by Pulse Width Modulated AC voltage controllers, which have a better overall performance; this is discussed in [2]. The simulation details and harmonic spectrum comparison with the phase control scheme is not provided in this paper. A single phase bi-directional AC power control circuit using power MOSFET embedded discrete component four quadrant switch realizations, that operate in a high frequency chopping mode, is presented in [3]. A new pulse width modulated control technique for AC choppers that has the advantages of enabling linear control of the fundamental component of the output voltage and complete elimination of its harmonics up to a specified order, is proposed in [4]. An optimal control strategy for selecting the firing and commutation angles in pulse width-modulated AC/AC chopper-type, single phase converters is proposed in [5]. The importance of the pulse width modulation scheme for a three phase circuit is presented in [6]. The neural network controlled energy saver scheme for a single phase induction motor is described in [7]. An improved voltage controller and control strategy for efficiency improvement of single phase induction motors is presented in [8]. The single phase AC chopper realized with IGBT's with high carrier wave frequency is described in [9]. A four quadrant HF AC Chopper without dead time is described in [10]. A detailed comparison between viable adaptive intelligent torque control strategies of induction motor is presented in [11]. In the literature [1–11] a model for closed loop AC Chopper fed single phase Induction Motor controlled by neural network is not presented. In this work a new Simulink model for the single phase induction motor is developed and the same is used for simulation studies. Closed loop stator voltage control is achieved successfully using the proposed neural network controller.

2 PWM AC Chopper Fed Induction Motor

A block diagrammatic representation of neural network controlled AC chopper fed single phase induction motor is shown in Fig. 1. The circuit can be operated directly from a single phase line and the voltage across each switch is limited to the line voltage. Various parameters, namely, pulse width modulated

voltage (E_a), stator current (I_1), speed (N) and error in speed (ΔN) are sensed and given to the neural network. It generates the driving pulses to the switches in order to maintain the speed of the machine at reference value. A neural network is proposed for speed regulation. During each run, the weights and biases of the NN are updated using the back propagation algorithm to make the error between the desired outputs and the actual outputs of the NN less than the predefined value.

The neural network controller has a 4-3-1 structure. The input layer (I/P) receives four inputs. The hidden layer (H/L) has three neurons. The output layer (O/P) has single neuron. This neural network structure is the result of many repeated trials. For each load, the training data is obtained by tuning the PI controller parameters, such as the proportional gain constant (k_p), and the integral gain constant (k_i) to optimal values in order to obtain the small steady state error.

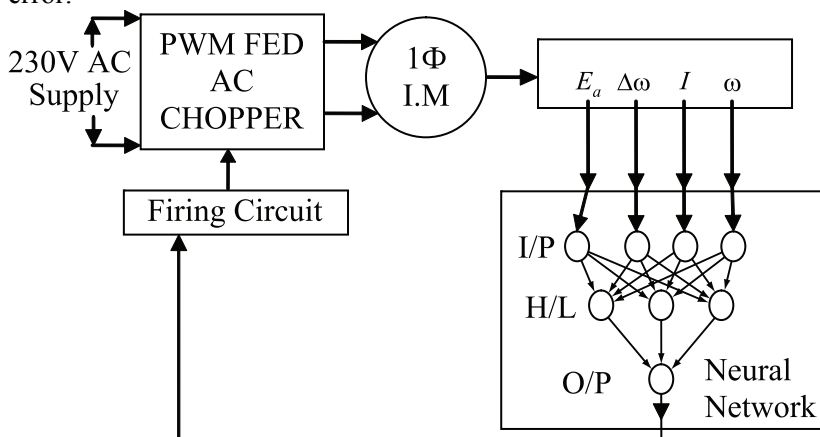

Fig. 1 – PWM AC Chopper fed Single Phase Induction Motor.

3 Simulink Model of Single Phase Induction Motor

The Simulink model of the single phase induction motor is shown in Fig. 2. Since the value of s is generally small, $r_2^1/2s$ is considerably higher than $r_2^1/[2 \cdot (2 - s)]$. In general, the magnitude of V_0 is 90% to 95% of the applied voltage. Hence, to obtain the simplified model of the single phase induction motor, the effect of the backward field is neglected.

The current flowing through the stator is expressed as

$$I_1 = \frac{V - V_0}{r_1 + jx_1} \tag{1}$$

If the rotor current referred to the stator is taken as I_2^1 , then the iron-loss and magnetizing component of a no-load current can be expressed as

$$I_0 = I_1 - I_2^1. \quad (2)$$

The output voltage can be obtained from the expression

$$V_0 = I_0 \frac{j r_0 x_0}{\left[4 \left(\frac{r_0}{2} + \frac{j x_0}{2} \right) \right]}. \quad (3)$$

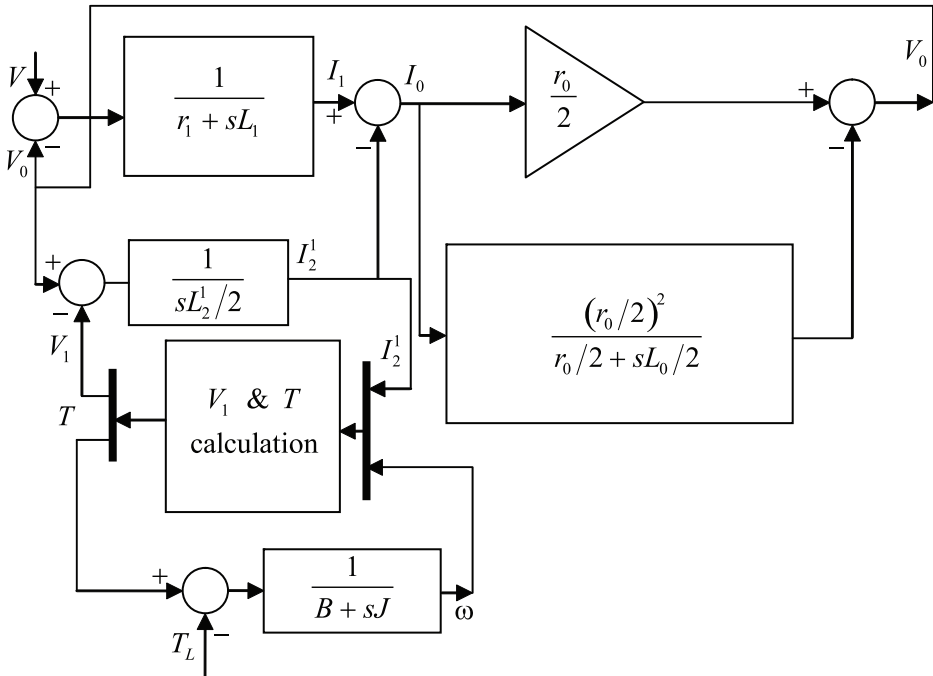

Fig. 2 – Simulink model of single phase induction motor.

It can be rewritten as:

$$V_0 = I_0 \left\{ \frac{r_0}{2} - \left[\frac{\left(\frac{r_0}{2} \right)^2}{\left(\frac{r_0}{2} + \frac{j x_0}{2} \right)} \right] \right\} \quad (4)$$

The voltage across the inductor $x_2^1/2$ is expressed as:

$$V_0 - I_2^1 \left(\frac{r_2^1}{s} \right). \quad (5)$$

The torque developed by the motor is given by the expression:

$$T = (I_2^1)^2 \frac{\left(\frac{r_2^1}{2s}\right)}{2\pi n_s} \quad (6)$$

The load balance equation is given by:

$$T = J \frac{d\omega}{dt} + B\omega + T_L \quad (7)$$

By using the above set of equations, the model for the single phase induction motor was obtained.

A 1.5kW, 230V single phase induction motor with the following parameters is used for simulation.

$$r_1 = 2 \Omega, \quad x_1 = 5.12 \Omega, \quad r_2 = 2.5 \Omega, \quad x_2 = 0.128 \Omega, \quad r_0 = 1 \text{ k}\Omega, \quad x_0 = 53.4 \Omega, \\ J = 0.0146 \text{ kgm}^2, \quad B = 0.001 \text{ Nms}, \quad \text{Turn ratio} = 1.99, \quad P = 4 \text{ poles}.$$

4 Harmonic Analysis of AC Chopper

The harmonic analysis has been performed for an Induction Motor model obtained with the above parameters. Using Matlab simulation, the harmonic spectrum has been obtained for both the Phase Controlled AC Chopper system and the Pulse Width Modulated AC Chopper system, and they are shown in Fig. 3. Using the Fourier analysis, the total harmonic distortion value has been calculated theoretically. The results of simulation closely agree with the theoretical values. Simulation has been performed for various delay angles and the modulation index values for both the Phase Controlled AC Chopper and the Pulse Width Modulated AC Chopper fed single phase Induction Motor systems calculated.

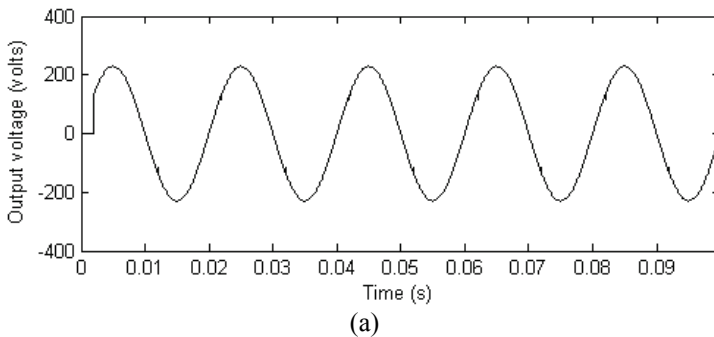
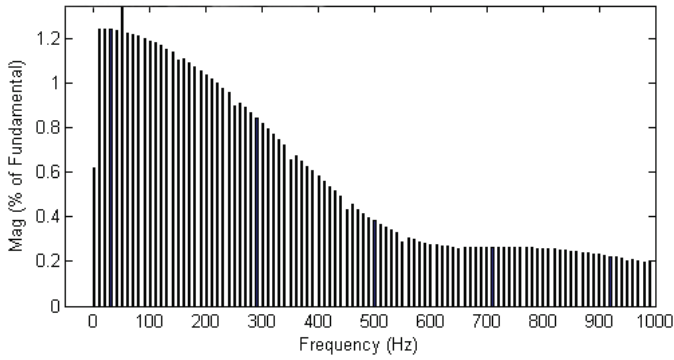
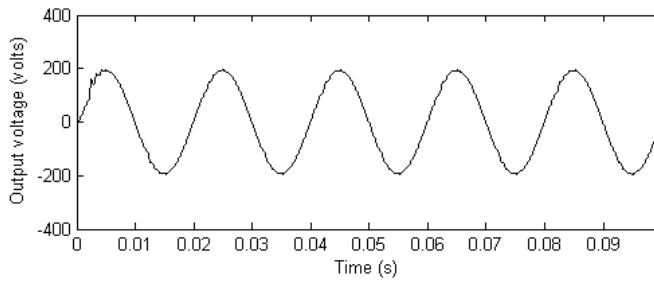

Fig. 3 – Harmonic spectrum of Phase Angle Controlled AC Chopper system and Pulse Width Modulated AC Chopper system:
(a) Phase controlled AC chopper, delay angle is 2ms;

Neural Network Based PWM AC Chopper Fed Induction Motor Drive



(b)



(c)

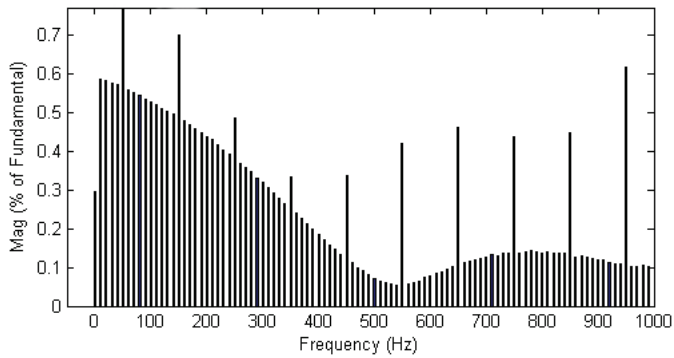

(d)

Fig. 3 – Harmonic spectrum of Phase Angle Controlled AC Chopper system and Pulse Width Modulated AC Chopper system:

- (a) Phase controlled AC chopper, delay angle is 2ms;
- (b) Frequency spectrum, THD is 2.62%;
- (c) PWM AC chopper, modulation index is 90%;
- (d) Frequency spectrum, THD is 1.67%.

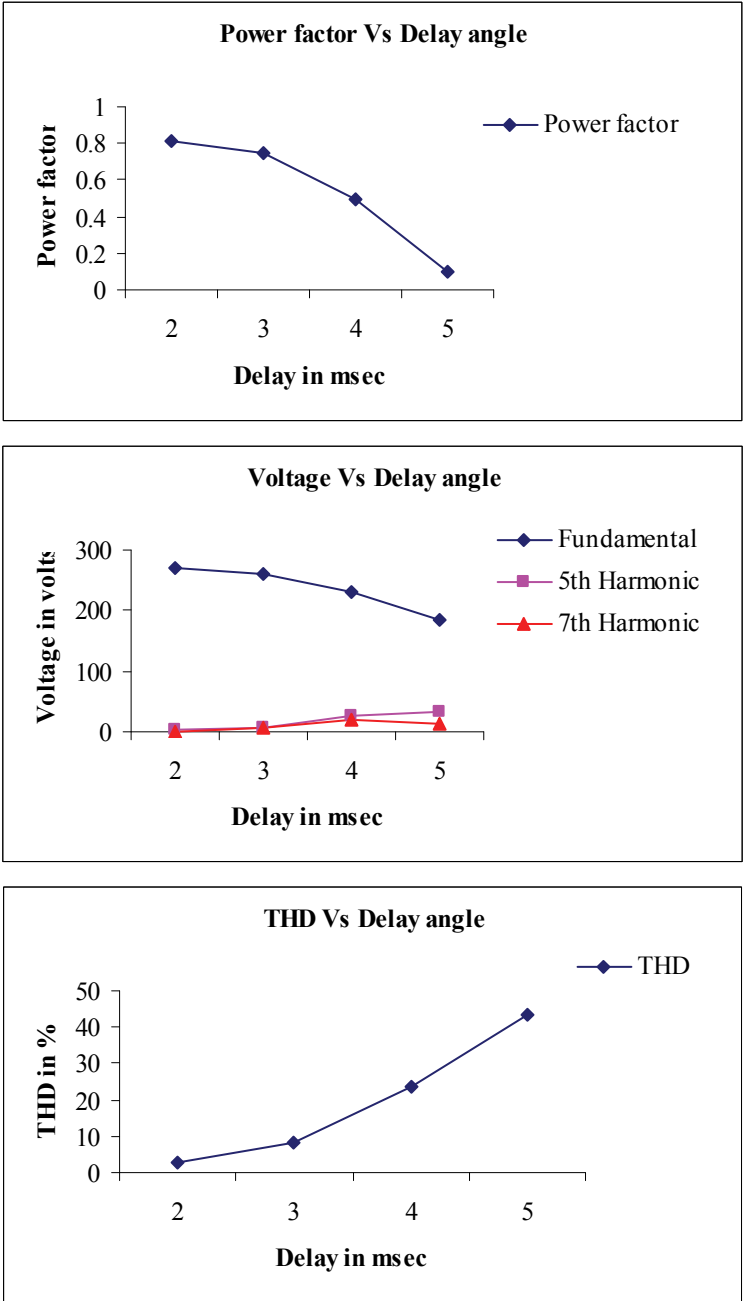

Fig. 4 – Harmonic analysis of Phase Angle Controlled AC chopper system.

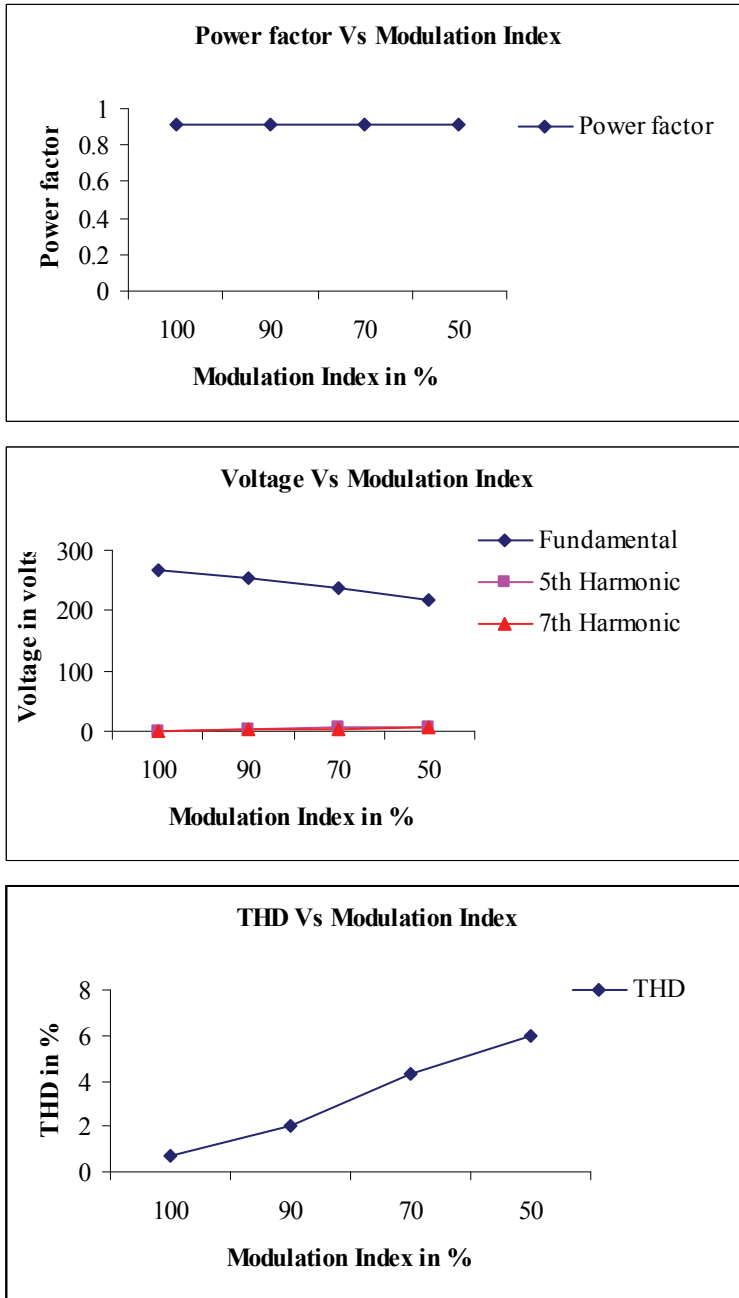

Fig. 5 – Harmonic analysis of PWM AC chopper.

The results are plotted and presented in Figs. 4 and 5 respectively. In order to improve the harmonic spectrum, a filter is introduced at the output terminals. Filter parameters are designed in such a way that the lower order harmonics are eliminated. For a modulation index of 90%, the value of THD is reduced from 4.6% to 2.03% using appropriate filter elements. The capacitor is introduced at the input side to act as a voltage suppressor. It suppresses the higher order noise.

From the curves of the harmonic analysis it can be seen that, the Phase controlled AC chopper has higher THD, poorer power factor and higher magnitudes of the fifth and seventh harmonic components. For the PWM controlled AC chopper, the output voltage has a THD value lesser than 6%. The power factor is improved and the magnitudes of the fifth and seventh harmonics are very much reduced. Because of the improved waveforms produced by the PWM AC Chopper, the performance of the single phase induction motor is improved.

5 Neural Network Controller

Neural networks are simply a class of mathematical algorithms, since a network can be regarded as a graphic notation for a large class of algorithms. The hidden layer transfer function is log-sigmoid or tan-sigmoid and the output transfer function is usually linear. Here, the tan-sigmoid is used as the hidden layer transfer function followed by the linear transfer function for the output layer.

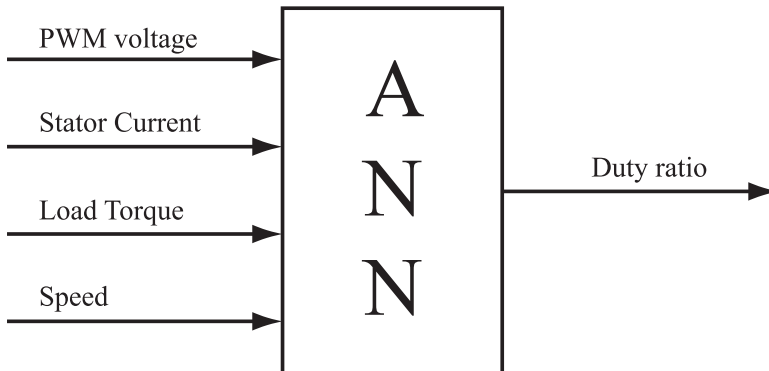

Fig. 6 – Neural Network system to estimate duty ratio of PWM AC chopper fed Single Phase Induction Motor.

These transfer functions are given in equations (8) and (9):

$$Y = \frac{1}{1 + e^{-(V_j X + B_1)}}, \quad (8)$$

$$O = W_{kj} Y + B_2, \quad (9)$$

where X is the input vector, Y and O are the output vectors of the hidden layer and output layer respectively, V_{ji} , W_{ji} are the weight matrices, and B_1 and B_2 are the bias vectors.

The neural network system to estimate the duty ratio of an AC chopper fed single phase Induction Motor is shown in Fig. 6.

6 Closed Loop Stator Voltage Controlled Single Phase Induction Motor

The neural network based closed loop stator voltage control of single phase induction motor system is shown in Fig. 7.

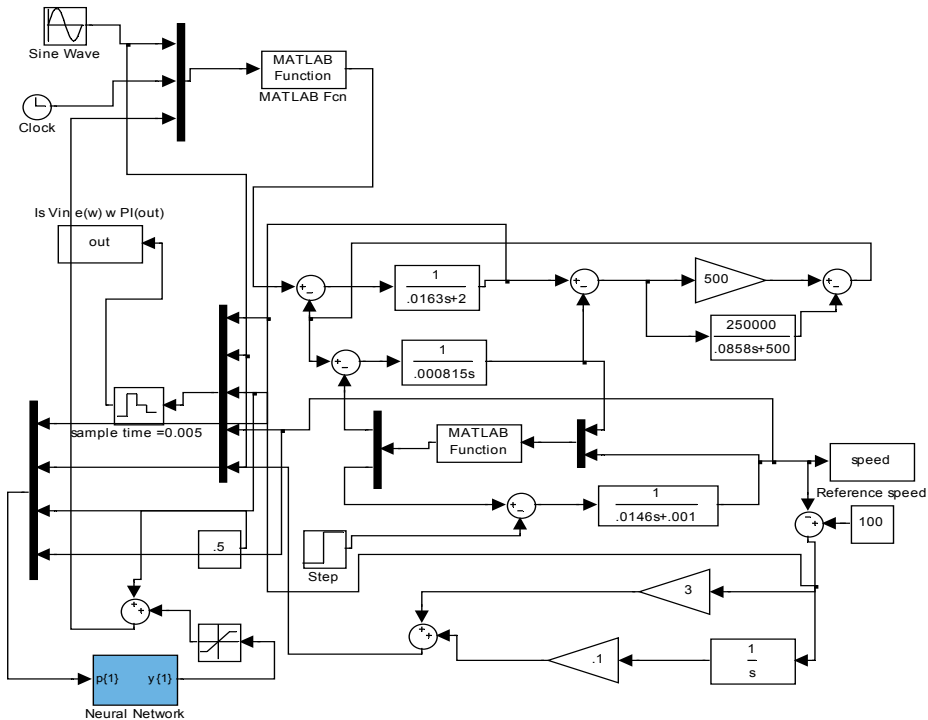

Fig. 7 – Model of PWM AC chopper fed Single Phase Induction Motor.

Here, the power circuit used to generate the Pulse Width Modulated AC voltage is modeled and used for simulation. PWM AC voltage is applied to the single phase induction motor and the speed is sensed by using a speed sensor. The actual speed of the motor is compared with the reference speed, which can be set by the industrial user according to their requirement. The error in speed is

given to the PI controller with the saturator. After tuning the parameters of the PI controller, various sets of training pattern for supply voltage, stator current, speed of the machine, error in speed and PI controller output are obtained. These patterns are used for training the neural network, using the error back propagation algorithm. After training the neural network successfully, the PI controller is replaced by the neural network controller and the simulation is performed.

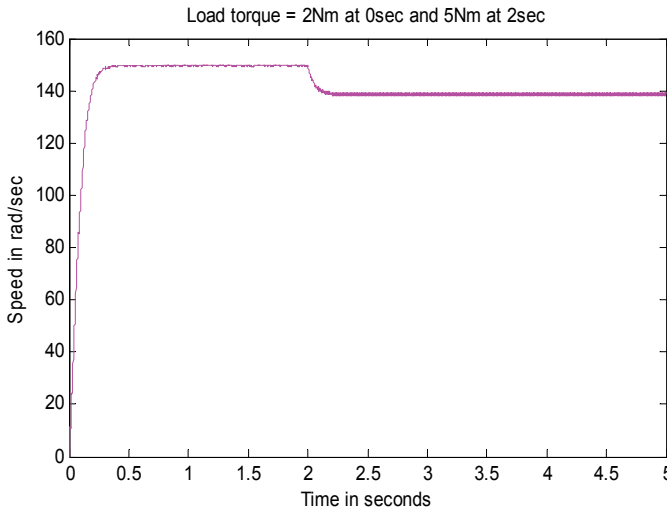

Fig. 8 – Speed response for open loop stator voltage control.

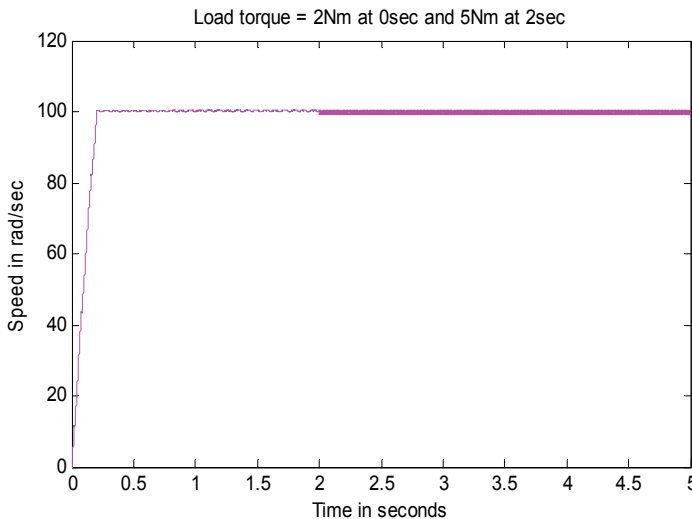

Fig. 9 – Speed response for closed loop stator voltage control.

The results of the simulation obtained using the neural network controller are compared with those of the PI controller. The output of the neural network controller is used to vary the modulation index of the PWM AC chopper. Based on the load torque applied to the machine, the neural network controller controls the modulation index. Hence, the speed of the machine is maintained constant at the reference speed. By using the neural network controller, the peak to peak ripple in speed is reduced by 15rpm when compared to that of the PI controlled system.

The speed response for the open loop system with an increase in load torque from 2Nm to 5Nm is shown in Fig. 8. From this figure, it can be seen that the speed is not constant in the open loop system. For a 2Nm load torque the speed is 151rad/s and for a 5 Nm load torque the speed reduces to 141rad/s. The speed is maintained at reference value irrespective of the load torque with the closed loop stator voltage control. The speed is maintained constant for the step variation of the load torque as shown in Fig. 9. The simulation is carried out for a reference speed of 100rad/s. The speed is maintained at 100rad/s as shown in Fig. 9.

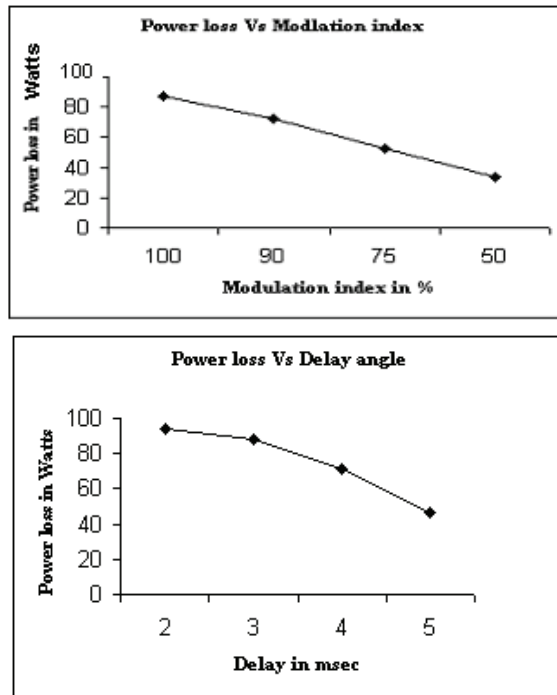

Fig. 10 – Copper loss for PWM and Phase Control techniques.

Copper losses for the Pulse Width Modulated AC Chopper and the Phase Controlled AC Chopper fed Single phase Induction motor are calculated for different delay angles and modulation index values. The simulation results are shown in Fig. 10.

For the same Induction machine the copper losses with the Pulse Width Modulated AC Chopper are 15% less than with the Phase controlled AC Chopper, and hence, it improves the efficiency and performance of the machine. For example, with 50% of modulation index the stator copper loss is 30W for the PWM AC Chopper and with 50% of maximum delay angle the stator copper loss is 45W for the phase angle controlled AC Chopper system.

7 Conclusion

Pulse Width Modulated AC Chopper and Phase Angle Controlled AC Chopper fed Induction motor systems are simulated and their performances are compared. It is proved that the Pulse Width Modulated AC Chopper has lesser Total Harmonic Distortion, better power factor and negligible harmonic components. It is shown that the Pulse Width Modulated AC Chopper has lesser copper loss than the Phase Controlled AC Chopper operating at the same load.

Modeling of an Induction Motor has been done and the closed loop control has been analyzed. Intelligent control technique using the neural network controller reduces the peak to peak ripple in speed compared to that of the conventional PI controller. It is shown that the speed of the machine remains constant with different values of load torques.

8 References

- [1] K.E. Addoweesh, A.L Mohamadein: Microprocessor based Harmonic Elimination in Chopper Type AC Voltage Regulators, IEEE Transactions on Power Electronics, Vol. 5, No. 2, Apr. 1990, pp. 191 – 200.
- [2] N.A. Ahmed, K. Amei, M. Sakui: A New Configuration of Single-phase Symmetrical PWM AC Chopper Voltage Controller, IEEE Transactions on Industrial Electronics, Vol. 46, No. 5, Oct. 1999, pp. 942 – 952.
- [3] A.N. Arvindan, V.K. Sharma, M. Subbiah: Selective Harmonic Elimination in a Microprocessor based Single Phase AC Chopper with Four Quadrant Switch Realizations, Proceedings of India International Conference on Power Electronics (IICPE '06), 19-21 Dec. 2006, Chennai, India, pp. 51 – 56.
- [4] G.H. Choe, A.K. Wallace, M.H. Park: An Improved PWM Technique for AC Chopper, IEEE Transactions on Power Electronics, Vol.4, No. 4, Oct. 1989, pp. 496 – 505.
- [5] D.A. Deib, H.W. Hill: Optimal Harmonic Reduction in AC/AC Chopper Converters, Proceedings of Power Electronics Specialists Conference (PESC '93), 20-24 June 1993, pp. 1055 – 1060.
- [6] M. Hunyar, K. Veszpremi: Pulse Width Modulated IGBT AC Chopper, Proceedings of Periodical Polytechnica Ser. Electrical Engineering, Vol. 45, No. 3-4, 2001, pp. 159 – 178.

- [7] V. Jamuna, S.R. Reddy: Neural Network Controlled Energy Saver for Induction Motor Drives, Proceedings of International Conference on Power Electronic Drives and Power Systems (POWER COIN '08) , Salem, India, 20-21 March 2008, pp. 36 – 37.
- [8] D.L. Joseph, A.L. Thomas: A Single Phase Induction Motor Voltage Controller with Improved Performance, IEEE Transactions on Power Electronics, Vol. PE-1, No. 4, Oct. 1986, pp. 240 – 247.
- [9] M. Lucanu, O. Ursaru, C. Aghion: Single Phase AC Chopper with IGBT's, Proceedings of International Symposium on Signals, Circuits and Systems (ISSCS '03), IEEE, 10-11 July 2003, Vol. 1, pp. 213 – 216.
- [10] S. Bean-Yaakov, Y. Hadad, N. Diamantstein: A Four Quadrants HF AC Chopper with no Dead Time, Proceedings of Applied Power Electronics Conference and Exposition (APEC'06), 21st Annual IEEE, 19-23 March 2006, pp. 1461 – 1465.
- [11] M. Vasudevan, R. Arumugam, S. Paramasivam: High-Performance Adaptive Intelligent Direct Torque Control Schemes for Induction Motor Drives, Serbian Journal of Electrical Engineering, Vol. 2, No. 1, May 2005, pp. 93 – 116.